

REPORT DOCUMENTATION PAGE

Form Approved
OMB NO. 0704-0188

Public Reporting burden for this collection of information is estimated to average 1 hour per response, including the time for reviewing instructions, searching existing data sources, gathering and maintaining the data needed, and completing and reviewing the collection of information. Send comment regarding this burden estimates or any other aspect of this collection of information, including suggestions for reducing this burden, to Washington Headquarters Services, Directorate for information Operations and Reports, 1215 Jefferson Davis Highway, Suite 1204, Arlington, VA 22202-4302, and to the Office of Management and Budget, Paperwork Reduction Project (0704-0188.) Washington, DC 20503.

1. AGENCY USE ONLY (Leave Blank)		2. REPORT DATE 11/28/00	3. REPORT TYPE AND DATES COVERED Final Report - 08/14/95 to 08/13/98	
4. TITLE AND SUBTITLE Research and Development of a Quasi-Optical Dielectric Slab Power Combining System			5. FUNDING NUMBERS DAAH 04-95-1-0536	
6. AUTHOR(S) Michael B. Steer				
7. PERFORMING ORGANIZATION NAME(S) AND ADDRESS(ES) North Carolina State University Box 7914 Raleigh, NC 27695-7914			8. PERFORMING ORGANIZATION REPORT NUMBER	
9. SPONSORING / MONITORING AGENCY NAME(S) AND ADDRESS(ES) U. S. Army Research Office P.O. Box 12211 Research Triangle Park, NC 27709-2211			10. SPONSORING / MONITORING AGENCY REPORT NUMBER ARO 34780.4-EL	
11. SUPPLEMENTARY NOTES The views, opinions and/or findings contained in this report are those of the author(s) and should not be construed as an official Department of the Army position, policy or decision, unless so designated by other documentation.				
12 a. DISTRIBUTION / AVAILABILITY STATEMENT Approved for public release; distribution unlimited.			12 b. DISTRIBUTION CODE	
13. ABSTRACT (Maximum 200 words) Two approaches to planar quasioptical power combining were considered. The two configurations are based on propagation characteristics of planar beam modes with a choice between them based on the level of conductive metallic losses which can become excessive at millimeter-wave frequencies and especially at near millimeter-wave frequencies. This report includes all of the publications product during the project.				
14. SUBJECT TERMS			15. NUMBER OF PAGES 46	
			16. PRICE CODE	
17. SECURITY CLASSIFICATION OR REPORT UNCLASSIFIED	18. SECURITY CLASSIFICATION ON THIS PAGE UNCLASSIFIED	19. SECURITY CLASSIFICATION OF ABSTRACT UNCLASSIFIED	20. LIMITATION OF ABSTRACT UL	

DTIC QUALITY IMPROVED

20010116 146

*Research and Development of a Quasi-Optical Dielectric
Slab Power Combining System*

Contract No. DAAH-04-95-1-0536

Final Report

Michael B. Steer

North Carolina State University

November 29, 2000

DISTRIBUTION STATEMENT A
Approved for Public Release
Distribution Unlimited

RESEARCH AND DEVELOPMENT OF A QUASI-OPTICAL DIELECTRIC SLAB POWER COMBINING SYSTEM

Final Report

by

Michael Steer

Introduction

In quasi-optical power combining systems the power from numerous active devices is combined in a propagating mode. Conventional power combining structures have the common property that power is combined in free space and the system is essentially three dimensional. In this project we investigated an alternative quasi-optical power combining strategy using a dielectric slab to combine the power from active devices in a mode which is confined to a two dimensional dielectric slab. We term this mode of operation quasi-optical slab space power combining. The aim of the work has been to develop a quasi-optical system which is more amenable to photolithographic definition and has reduced size because the signal is confined to the dielectric. The progress of the work is fully described in the papers attached to this report.

Two approaches to planar quasi-optical power combining were considered. The two configurations are based on propagation characteristics of planar beam modes with a choice between them based on the level of conductive metallic losses which can become excessive at millimeter-wave frequencies and especially at near millimeter-wave frequencies.

Our research and development efforts were guided by the following principles:

1. Design choices must be compatible with monolithic integration. One implication of this is that active devices should be located at the base of the slab in the ground plane which in addition aids an heat removal.
2. Design choices must be compatible with millimeter and near-millimeter wave operation. The main consequence here is that metallic losses must be minimized by keeping peak fields away from metal surfaces.

2D TE Mode QO Power Combining Amplifier

The bulk of the project was concerned with the development of the TE version of a slab quasi-optical amplifier and all of the papers listed refer to this type of amplifier. The design work progressed from developing an understanding of the modes in a quasi-optical slab system to the development of a passive structure that supported propagation of signals that could be amplified. The mode understanding supported this TE implementation as well as the TM implementation described briefly below. The final

amplifier construction yielded reasonable power combining efficiency but only over an extremely narrow bandwidth.

2D TM Mode QO Power Combining Amplifier

Construction of this amplifier was not successful and it was determined that this was due to inadequate electromagnetic modeling. Work on this amplifier, involving considerable modeling, is continuing in another program.

Conclusion

The first demonstration of power amplification in a hybrid quasi-optical dielectric slab system was demonstrated. The results were a proof of principle and the main conclusion is that future development requires development of specific EM modeling tools. Specific performance of the final design is given in References [1,3].

Publications

The work performed is described and documented in papers a list of which is given below and copies of the papers are included as part of this report.

1. C. W. Hicks, H.-S. Hwang and M. B. Steer, J. W. Mink, and J. Harvey, "Spatial power combining for two dimensional structures," *IEEE Trans. On Microwave Theory and Techniques*, June, 1998, pp. 784-791.
2. H. Hwang, T. W. Nuteson, M. B. Steer, J. W. Mink, J. Harvey and A. Paoletta, "A quasi-optical dielectric slab power combiner," *IEEE Microwave and Guided Wave Letters*, Vol. 6, February 1996 pp. 73-75.
3. H.-S. Hwang, C. W. Hicks, M. B. Steer, J. Harvey and J. W. Mink, "A quasi-optical dielectric slab power amplifier with a large amplifier array," *Proc. 1998 IEEE Antennas and Propagation Symposium*, June 1998, pp. 482-485.
4. J. W. Mink, H. Hwang, T. W. Nuteson, M. B. Steer and J. Harvey, "Spatial power combining for two-dimensional structures," *Proc. 1997 Topical Symposium on Millimeter Waves*, July 1997.
5. H. Hwang, T. W. Nuteson, M. B. Steer, J. W. Mink, J. Harvey and A. Paoletta, "Slab-based quasi-optical power combining system," *Proc. 20th Infrared and Millimeter-Wave Conf.*, December 1995, pp. 157-158.
6. H. Hwang, T. W. Nuteson, M. B. Steer, J. W. Mink, J. Harvey and A. Paoletta, "Quasi-optical power combining techniques for dielectric substrates," *Int. Semiconductor Device Research Symp.*, December 6-8, 1995, pp. 243-246.

7. H. Hwang, T. W. Nuteson, M. B. Steer, J.W. Mink, J. Harvey and A. Paoletta, "Quasi-optical power combining in a dielectric substrate," *Int. Symp. on Signals, Systems and Electronics, URSI Symp.*, October 25-27, 1995, pp. 89-92.
8. H. Hwang, G. P. Monahan, M. B. Steer, J. W. Mink, and F. K. Schwing, "A dielectric slab waveguide with four planar power amplifiers," *1995 IEEE MTT-S Int. Microwave Symp. Digest*, May 1995, pp. 921-924
9. F. Poegel, S. Irrgang, S. Zeisberg, A. Schuenemann, G. P. Monahan, H. Hwang, M. B. Steer, J. W. Mink, and F. K. Schwing, "Demonstration of an oscillating quasi-optical slab power combiner," *1995 IEEE MTT-S Int. Microwave Symp. Digest*, May 1995, pp. 917-920.
10. H. Hwang, G. P. Monahan, M. B. Steer, J. W. Mink, and F. K. Schwing, "A dielectric slab waveguide with four planar power amplifiers," *1995 IEEE MTT-S Int. Microwave Symp. Digest*, May 1995, pp. 921-924.

Spatial Power Combining for Two Dimensional Structures

J.W. Mink, H.-S. Hwang, C.W. Hicks[†], T.W. Nuteson, M.B. Steer, and J. Harvey^{*}
 Electronics Research Laboratory, Department of Electrical and Computer Engineering,
 North Carolina State University, Raleigh, NC 27695-7911
 919-515-5090 (office) 919-515-5601 (Fax)

[†]Naval Air Warfare Center Aircraft Division, Patuxent River MD 20670

^{*}United States Army Research Office, PO Box 12211, Research Triangle Park, NC 27709

Abstract—A hybrid dielectric slab-beam waveguide is suitable for the design of planar quasi-optical integrated circuits and devices. In this paper a 2-D quasi-optical power-combining system with convex and concave lenses was investigated. The system employs an active E-plane amplifier array consisting of Vivaldi-type antennas with MESFET and MMIC devices. The system was tested by switching the amplifier bias off and on while measuring the power with an E-plane horn. Tests were performed with a single MMIC amplifier and a 4 x 1 MESFET amplifier array. The amplifier array generated 11 dB and 4.5 dB of amplifier and system gain respectively at 7.12 GHz, and the single MMIC Vivaldi-type antenna produced 24 dB of amplifier gain at 8.4 GHz.

I. INTRODUCTION

Spatial power combining has emerged as a promising technique for power combining at millimeter and sub-millimeter wave frequencies. One embodiment of spatial power combining is quasi-optical power combining based on the principle that radiated fields produced by an array of solid state active devices may be combined. The fields are combined utilizing wavebeam principles in free space or dielectric material to generate reliable power. Periodic refocusing of the beam is accomplished by the use of optical lenses to combine the power in a single paraxial mode. The large transverse and longitudinal dimensions of the quasi-optical structures provide significant area for the active MMIC devices and control components to be included within the structure. The most mature quasi-optical structures include grid amplifiers and resonant cavities where the power is combined in three-dimensional space (3-D) [1, 2]. However, two-dimensional (2-D) technology offers an alternative approach with significant advantages. Mink and Schwering [4] proposed a 2-D hybrid dielectric slab-beam waveguide (HDSBW) which is more amenable to photolithographic definition and fabrication, and is more compatible with the MMIC technology [5,6]. The 2-D HDSBW has reduced size and weight, and improved heat removal capability which results in lower costs.

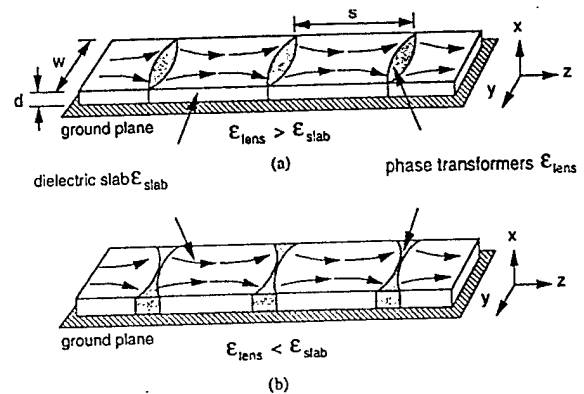

Figure 1: Passive 2D quasi-optical power combining system (a) convex lenses and (b) concave lenses.

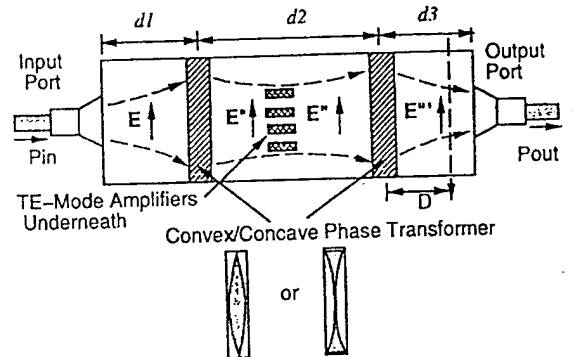

Figure 2: The HDSBW system with convex/concave lenses and 4 x 1 MESFET amplifier array.

IV. PRINCIPLES OF OPERATION

The HDSBW uses two distinct waveguiding principles to guide the electromagnetic wave [5,7]. The input energy travels in a Gaussian-Hermite mode along the slab waveguide. In the x-direction, the field distribution is that of a surface-wave mode of the grounded dielectric slab;

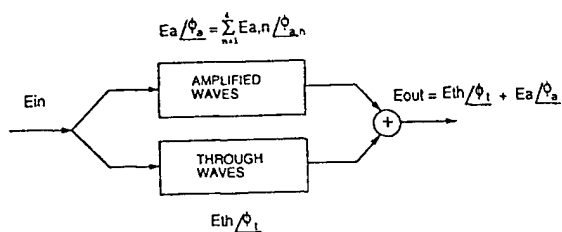
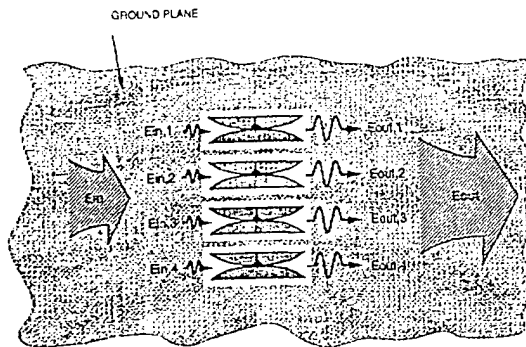

Figure 3: Wave model for 2D power combining

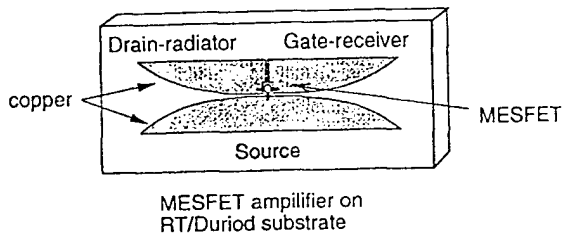

Figure 4: MESFET Vivaldi amplifier

the wave is guided by total reflection at the air-to-dielectric interface and parameters are adjusted such that energy is transmitted primarily within the dielectric. In the y-direction the field distribution is that of a wave beammode (Gauss-hermite) which is guided by the lenses through periodic reconstitution of the cross sectional phase distribution. The guided modes can be either TE or TM polarized with respect to the direction of propagation whose period is the spacing of the lenses. Figure 1 shows the passive HDSBW employing two examples of periodic refocusing. Figure 1(a) shows convex lenses that are utilized to periodically reset the wavebeam phase and Figure 1(b) displays this principle by utilizing concave lenses.

The principle employed here to obtain signal amplification is similar to that of a traveling wave amplifier. An array of active elements located underneath the dielectric slab is placed in the path of the wavebeam as shown in Figure 2. Each active element consists of a pair of back-to-back Vivaldi antennas with an amplifier inserted between the

two antennas. Part of the incident signal, the thru wave, passes through the dielectric slab undisturbed. The remaining signal is amplified by the array. The first Vivaldi antenna couples energy from the incident traveling wavebeam, and the second Vivaldi antenna reinserts the amplified signal back into the traveling wave beam. Maximum coupling to the array occurs when the energy from the first lens focuses energy to the input of the Vivaldi antennas. The signal is amplified by the MESFETs and is coupled by the output Vivaldi antennas to the traveling wavebeam where it combines in phase with the through signal as shown in Figure 3. Consequently, a growing traveling wavebeam mode is established within the guiding structure resulting in increased output power.

III. SYSTEM CONFIGURATION

The system configuration for the HDSBW shown in Figure 2 consists of rectangular dielectric slab made of Rexolite ($\epsilon_r = 2.57$, $\tan\delta = 0.0006$) placed on a conducting ground plane. Two concave cylindrical lenses made of Macor ($\epsilon_r = 5.9$, $\tan\delta = 0.0006$) with focal lengths equal to 28.54 cm were inserted between the dielectric slab. The dielectric slab dimensions length ($d_1 + d_2 + d_3$), width (w) and thickness (d) were 62 cm, 27.94 cm and 1.27 cm respectively. The Vivaldi antenna MESFET amplifiers were located underneath the dielectric slab in the ground plane. Each Vivaldi antenna was fabricated using RT/Duroid 6010 substrate ($\epsilon_r = 10.2$, $\tan\delta = 0.0028$) with the dimensions 6.5 cm x 1.5 cm. Two E-plane horns were designed and fabricated that efficiently launch and receive the required wavebeam.

V. EXPERIMENTAL RESULTS

Two tests were performed, the first utilized a 4 x 1 MESFET Vivaldi amplifier array as shown in Figure 2, and the second employed a single MMIC Vivaldi amplifier located under the dielectric slab (see Figure 6). A measure of the relative energy coupled to the amplifier array was obtained by switching the amplifier bias levels off and on while measuring the output power, P_{out} . The system performance for the active Vivaldi amplifier array was determined by the system gain and amplifier gain. This provided an indication of the incident signal that passes through the dielectric as an undisturbed traveling wave.

Figure 5 shows the total system performance of the MESFET amplifier array at 7.12 GHz using concave lenses. A plot of P_{in} versus P_{out} is indicated by AMP OFF and AMP ON respectively. The input power, P_{in} varied from -45 dBm to +10 dBm in +5 dBm increments. The power ratio between P_{out} and P_{in} was relatively constant for P_{in} less than -15 dBm, however P_{out} reached the

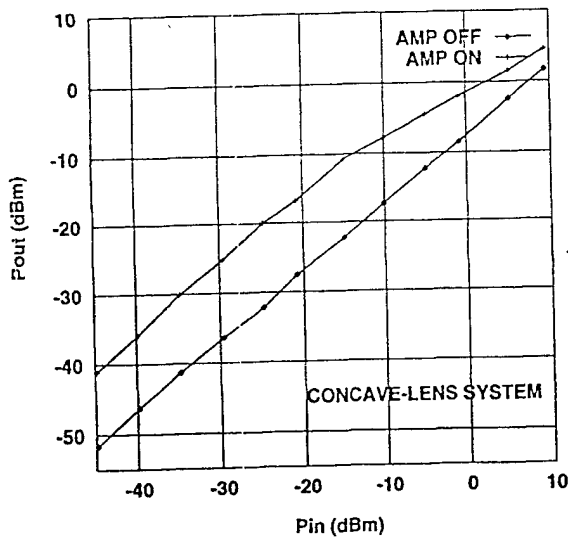

Figure 5: Input and output power of the concave-lens 4 x 1 MESFET array.

saturation condition with P_{in} greater than -15 dBm. The maximum system gain of 4.5 dB occurred at $P_{in} = -15$ dBm while the amplifier gain on to off measured was 11 dB.

The second test was performed with a cascaded pair of MMIC amplifiers in order to achieve higher power levels. In Figure 6, the amplifier gain of the Vivaldi amplifier was determined by placing a metal screen transverse to the Vivaldi structure. The Vivaldi amplifier and the metal wall were placed 5.5 cm and 9.7 cm respectively from the input horn. A concave lens was placed in the middle of a 40 cm dielectric slab. The slit in the metal wall allowed for only input power of the amplifier and the amplified energy to go through the system so that the amplifier gain could be measured. The amplifier gain shown in Figure 7 was determined by switching the bias voltage on and off, while measuring the power difference detected by the receiving horn. The amplifier gain indicates that more than 10 dB of gain was produced from 7 GHz to 10.4 GHz with a maximum gain of 24 dB at 8.4 GHz.

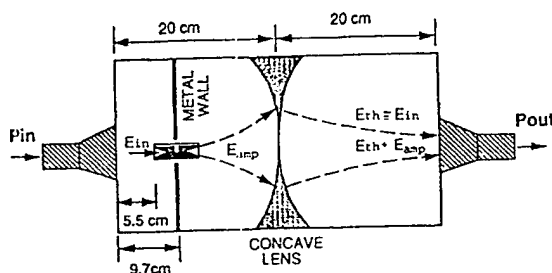

Figure 6: The concave-lens system configuration for a unit cell amplifier

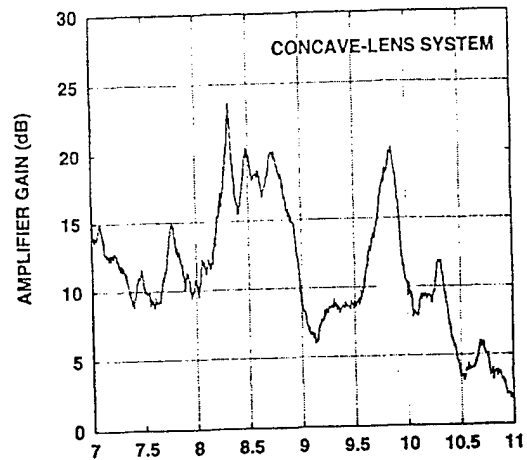

Figure 7: Amplifier gain for a unit cell amplifier with cascaded MMIC chips.

VI. CONCLUSIONS

A 2-D HDSBW spatial power combining system suitable for planar integrated circuits and devices has been presented. A system using concave lenses and Vivaldi-type antennas with MESFET and MMIC devices has been demonstrated. The 4 x 1 MESFET amplifier array produced 11 dB of amplifier gain and 4.5 dB of system gain at 8.4 GHz. Operating at 7.12 GHz, a single MMIC amplifier produced 24 dB of amplifier gain. By combining more MMIC instead of MESFETs greater power can be achieved. This paper shows that 2D spatial system is suitable for planar MMIC technology.

ACKNOWLEDGMENTS

The work was support by the U.S. Army Research Office in Research Triangle Park, NC and the Naval Air Warfare Center Aircraft Division, RF Sensor Branch, Code 4.5.5.5, in Patuxent River, MD.

REFERENCES

- [1] J.W. Mink, "Quasioptical power combining of solid-state millimeter-wave sources," *IEEE Trans. Microwave Theory Tech.*, vol. 34, pp. 273-279, Feb. 1986.
- [2] Z.B. Popovic, R. M. Weilke, M. Kim and D.B Rutledge, "A 100-MESFET planar grid oscillator," *IEEE Trans. on Microwave Theory and Techniques*, vol. MTT-39, pp. 193-200, Feb. 1991.
- [3] H. Hwang, G.P. Monahan, M.B. Steer, J.W. Mink, J. Harvey, A. Paolletta, and F. K. Schwing, "A dielectric slab waveguide with four planar power amplifiers," in *IEEE MTT-S Int. Microwave Symp. Dig.*, May 1995, pp. 921-924.
- [4] J.W. Mink and F.K. Schwing, "A hybrid dielectric slab-beam waveguide for the millimeter wave region," *IEEE Trans. Microwave Theory Tech.*, vol. 41, pp. 1720-1729, Oct. 1993.

- [5] F. Poegel, S. Irrgang, S. Zeisberg, A. Schuenemann, G. P. Monahan, H. Hwang, M. B. Steer, J. W. Mink, F. K. Schwing, A. Paolletta and J. Harvey, "Demonstration of an oscillating quasioptical slab power combiner." in IEEE MTT-S Int. Microwave Symp. Dig., May 1995, pp. 917-920.
- [6] A. R. Perkons and Tatsuo Itoh, "A 10-element active lens amplifier on a dielectric slab," IEEE MTT-S Int. Microwave Symp. Dig., pp. 119-1122, June 1996.
- [7] R. A. York, Z. B. Popovic, Active and quasi-optical arrays for solid-state power combining, John Wiley & Sons, Inc. 1997, pp. 277-292.

A Quasi-Optical Dielectric Slab Power Combiner

Huan-sheng Hwang, *Student Member, IEEE*, Todd W. Nuteson, *Student Member, IEEE*,
Michael B. Steer, *Senior Member, IEEE*, James W. Mink, *Fellow, IEEE*,
James Harvey, *Member, IEEE*, and Arthur Paoella, *Member, IEEE*

Abstract—Real power gain from a quasi-optical power combining dielectric slab waveguide amplifier system is reported for the first time. The system employs four MESFET amplifiers located under the slab, and a small signal gain of 10.5 dB was achieved. Measurements of insertion loss and E-field patterns are presented.

I. INTRODUCTION

In quasi-optical power combining systems, the power from numerous solid state devices is combined into one dominant propagating mode. The most mature quasi-optical systems include grid oscillators [1], [2] and amplifiers [3], resonant cavity oscillators [4], [5], and similar structures with the common property that power is combined in free space and the system is essentially three dimensional (3-D). We have recently investigated quasi-optical systems using a dielectric slab [6]–[8] to combine the power from the active devices in a mode that is confined to a two-dimensional (2-D) dielectric slab. Using a dielectric slab rather than free space for guiding the propagating wave allows for planar MMIC fabrication.

A dielectric slab beam waveguide (DSBW) system with amplifiers is shown in Fig. 1. The DSBW system uses Rexolite ($\epsilon_r = 2.57$) for the dielectric slab and Macor ($\epsilon_r = 5.9$) for the lenses, with a radius of 30.48 cm and focal length of 28.54 cm. For the dimensions shown in Fig. 1, $d_1 = 12$ cm, $d_2 = 28$ cm, and $d_3 = 16$ cm. The width of the slab waveguide is 30.48 cm. The aperture width of both horn antennas is 9 cm, designed to be the spot size of the slab beam-mode near the aperture. Energy propagates in a TE Gaussian beam mode along the waveguide, passes the lenses, and is refocused in the middle area of the waveguide. The beam in that area has the strongest field strength and its width is close to that of the beam width near the radiator. Four MESFET amplifiers, each consisting of one MESFET with two Vivaldi antennas (see Fig. 1), are located in this area to amplify the guided energy and are placed underneath the slab so that they do not distort the fields. The design of the amplifiers is discussed in [8].

In this letter, we report for the first time real power gain from the DSBW system. With an RF input power level of -15.5 dBm at 7.384 GHz, the output power was measured

Manuscript received July 17, 1995. This work was supported in part by the U.S. Army Research Office through grant DAAL03-89-G-0030.

H.-s. Hwang, T. W. Nuteson, M. B. Steer, and J. W. Mink are with the Electronics Research Laboratory, Department of Electrical and Computer Engineering, North Carolina State University, Raleigh, NC 27695-7911 USA.

J. Harvey is with the U.S. Army Research Office, Research Triangle Park, NC 27709-2211 USA.

A. Paoella is with the Microwave and Lightwave Components Division, AMSRL-EP-MA, U.S. Army Research Laboratory, NJ 07703 USA.
Publisher Item Identifier S 1051-8207(96)00910-1.

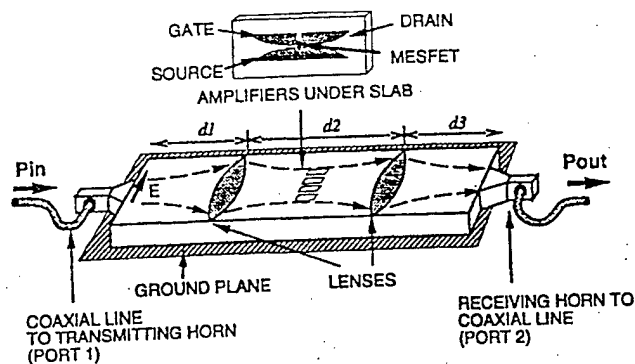

Fig. 1. DSBW system with MESFET amplifiers.

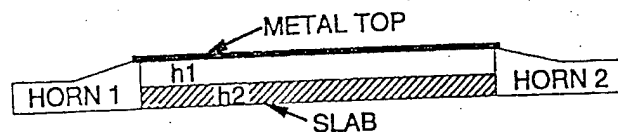

Fig. 2. Side view of system with metallic top.

to be -5 dBm. This represents a 10.5 dB gain of real power from the complete system including losses due to the coax to waveguide transition, horn aperture, dielectric slab, lenses, and radiated power into free space. Adding a metallic top cover to the system to reduce the power lost from free space radiation resulted in an overall increase of 2 dB in the output power level. Measurements for amplifier gain, system gain, insertion loss, and E-field patterns are also presented. The reference planes for all of the 2-port measurements are at the coaxial line and include the coax to waveguide transition as is shown in Fig. 1. The side view of the DSBW system with a metallic top is shown in Fig. 2 ($h_1 = 1.6$ cm, $h_2 = 1.27$ cm).

II. EXPERIMENTAL RESULTS

The amplifier gain of the four MESFET amplifiers in the DSBW system is shown in Fig. 3. With no metallic top cover the gain was close to 15 dB and with the cover was 12.5 dB both at a frequency of 7.384 GHz. This gain was measured by taking the ratio of the amplifiers with the dc bias on and off. Fig. 4 shows the gain of the complete system with the amplifiers turned on. The solid line is the reverse transmission $|S_{12}|$ and the dotted line is the forward transmission $|S_{21}|$. $|S_{12}|$ shows that the back scattering to the input port is very minimal, and $|S_{21}|$ shows that positive power gain is achieved

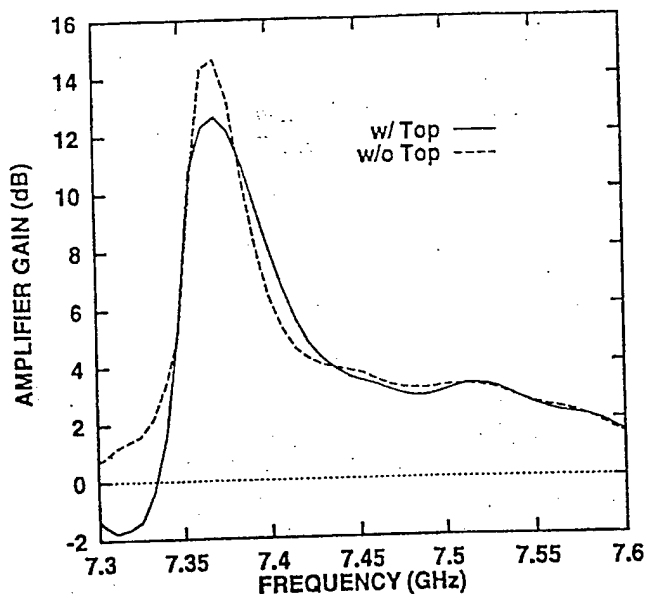

Fig. 3. Amplifier gain of four MESFET amplifiers in the DSBW system with and without a metallic top cover as $P_{in} = -10$ dBm. The gain here is the ratio of the power received with the amplifiers on (biased) to that with the amplifiers off (not biased).

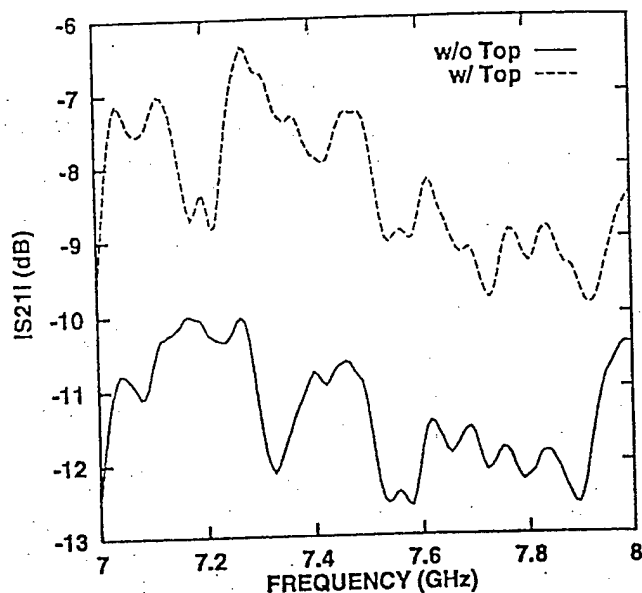

Fig. 5. Measured response of the passive DSBW amplifier system (no bias) with and without a metallic top cover. Without the cover, the system loss is 10–12.5 dB. With the cover, the system loss is 6.5–9 dB.

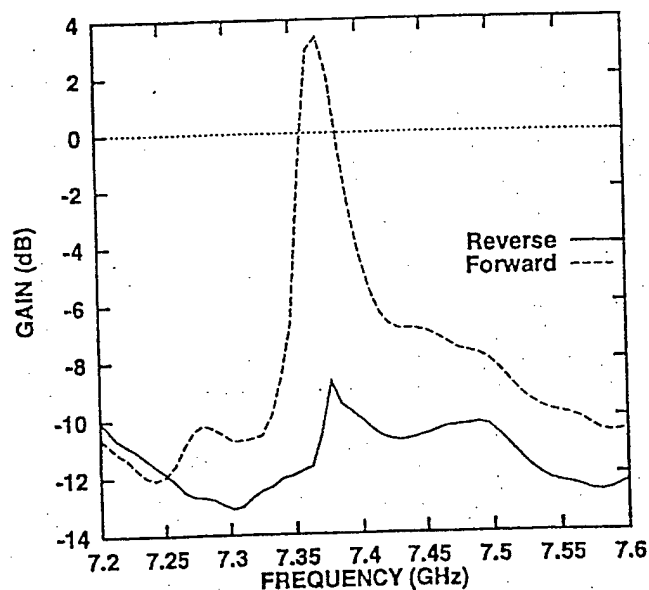

Fig. 4. Forward and reverse transmission through the DSBW amplifier system at $P_{in} = -10$ dBm. This is the real gain measured at the external ports.

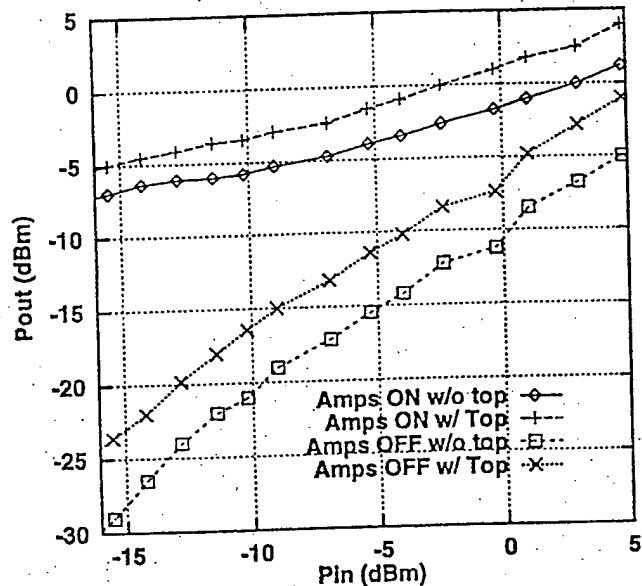

Fig. 6. P_{out} versus P_{in} of the DSBW amplifier system. Without top, the small signal gain was 8.5 dB in spite of a system loss about 11.5 dB. With top, the small signal gain was 10.5 dB in spite of a system loss about 7.5 dB.

through the complete system. The input power level was -10 dBm. The loss through the passive DSBW system is shown in Fig. 5. Here the amplifiers are in the system without bias. With the metallic top cover the loss is about 3.5 dB less than without the cover. Sources of loss include input/output mismatch, radiation loss of horns, insertion loss of amplifiers and lenses, which cause field scattering and diffraction. We expect to drastically reduce these losses in the future.

The main goal of this paper is presented in Fig. 6 where we achieve real power gain, $(P_{out} - P_{in})$, in the DSBW amplifier system. The measurements were taken at a frequency of 7.384 GHz where the amplifier gain was maximum.

The highest power gain achieved was 10.5 dB with top and 8.5 dB without top with the input power level at -15 dBm. When the amplifiers were turned off, the slope in Fig. 6 was close to 1:1. As the amplifiers were turned on and P_{in} was higher than -15 dBm, P_{out} entered the saturation region, and hence the slope was less than 1:1.

The power-added efficiency is 5.2% when the input power is at 5 dBm. This is low and is being addressed.

Fig. 7 shows the power distribution across the top of the DSBW system for three cases: amplifiers with bias, amplifiers without bias, and no amplifiers in the system. With the amplifiers biased the power distribution spreads wider across the slab, whereas with the amplifiers not biased or not in the

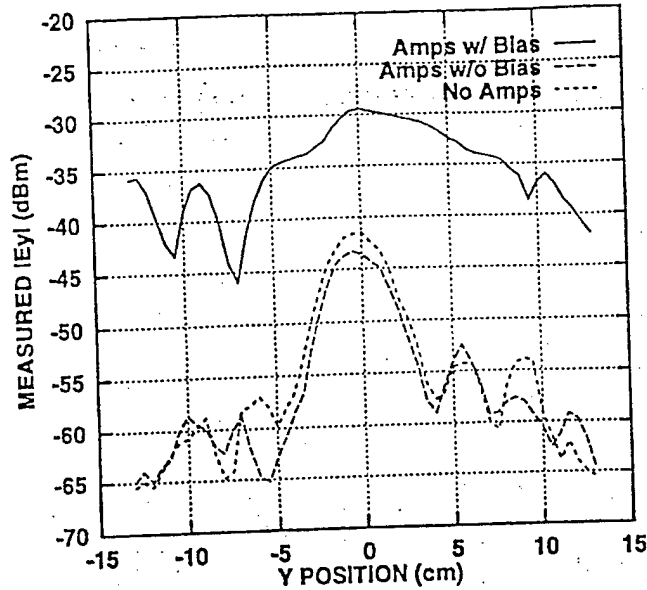

Fig. 7. Measured $|E_y|$ distribution across the top of the DSBW amplifier system.

system the power distribution has more distinctive Gaussian shape. As indicated in Fig. 7, the field distribution is little affected by the ground discontinuities due to the amplifier unit cells. In contrast, with the amplifiers on the top of the slab waveguide as in [8], significant scatter is introduced. With the amplifiers are biased, the field distribution spreads out presumably due to the additional phase delay through the amplifiers. This indicates that a refinement of the lens and/or receiver positioning and design is required to capture all the amplified energy in the system.

III. CONCLUSION

The real power gain using quasi-optical power combining techniques in a DSBW amplifier system was reported for the first time. The highest power gain was reported to be 10.5 dB at 7.384 GHz when the input power level was -15 dBm. The planar amplifiers are suitable for use with the DSBW system and can be applied to planar MMIC technology.

REFERENCES

- [1] J. B. Hacker, M. P. de Lisio, M. Kim, C.-M. Liu, S.-J. Li, S. W. Wedge, and D. B. Rutledge, "A 10-watt X-band grid oscillator," in *IEEE MTT-S Int. Microwave Symp. Dig.*, May 1994, pp. 823-826.
- [2] Z. B. Popovic, R. M. Weikle II, M. Kim, and D. B. Rutledge, "A 100-MESFET planar grid oscillator," *IEEE Trans. Microwave Theory Tech.*, vol. 39, pp. 193-200, Feb. 1991.
- [3] M. Kim, J. J. Rosenberg, R. P. Smith, R. M. Weikle II, J. B. Hacker, M. P. DeLisio, and D. B. Rutledge, "A grid amplifier," *IEEE Microwave Guided Wave Lett.*, vol. 1, pp. 322-324, Nov. 1991.
- [4] J. W. Mink, "Quasioptical power combining of solid-state millimeter-wave sources," *IEEE Trans. Microwave Theory Tech.*, vol. MTT-34, pp. 273-279, Feb. 1986.
- [5] P. L. Heron, G. P. Monahan, J. W. Mink, F. K. Scherwing, and M. B. Steer, "Impedance matrix of an antenna array in a quasioptical resonator," *IEEE Trans. Microwave Theory Tech.*, vol. 41, pp. 1816-1826, Oct. 1993.
- [6] J. W. Mink and F. K. Scherwing, "A hybrid dielectric slab-beam waveguide for the sub-millimeter wave region," *IEEE Trans. Microwave Theory Tech.*, vol. 41, pp. 1720-1729, Oct. 1993.
- [7] F. Poegel, S. Irrgang, S. Zeisberg, A. Schuenemann, G. P. Monahan, H. Hwang, M. B. Steer, J. W. Mink, F. K. Scherwing, A. Paolletta, and J. Harvey, "Demonstration of an oscillating quasioptical slab power combiner," in *IEEE MTT-S Int. Microwave Symp. Dig.*, May 1995, pp. 917-920.
- [8] H. Hwang, G. P. Monahan, M. B. Steer, J. W. Mink, J. Harvey, A. Paolletta, and F. K. Scherwing, "A dielectric slab waveguide with four planar power amplifiers," in *IEEE MTT-S Int. Microwave Symp. Dig.*, May 1995, pp. 921-924.

Experimental Investigation of a Quasi-Optical Slab Resonator

S. Zeisberg, *Student Member, IEEE*, A. Schuenemann, *Student Member, IEEE*, G. P. Monahan, *Student Member, IEEE*, P. L. Heron, M. B. Steer, *Senior Member, IEEE*, J. W. Mink, *Fellow, IEEE*, and F. K. Schwing, *Fellow, IEEE*

Abstract—A quasi-optical slab resonator for TE modes was experimentally characterized to demonstrate a planar technology for quasi-optical devices. Predicted and measured frequencies of resonance of the TE slab modes and electric field profiles are in close agreement.

I. INTRODUCTION

QUASI-OPTICAL propagation is an attractive means for routing signals at millimeter-wave frequencies and above. This is partly because lateral dimensions are relaxed and because waveguiding is not dependent on metallic conductors which become excessively lossy at these frequencies. Instead signals propagate in a dielectric medium and are periodically refocused using lenses and/or reflectors [1], [2]. Almost all of the functions available in conventional (conductor-based) waveguiding are available by placing functional components in the quasi-optical beam [2], [3]. Complete quasi-optical signal processing systems however cannot be photolithographically defined thus limiting mass production and contributing to high cost. With the aim of developing a waveguiding medium which is more amenable to photolithographic reproduction and also with reduced size, Mink and Schwing have proposed a hybrid dielectric slab-beam waveguide (HDSBW) [4]. This structure combines the wave-guiding principles of dielectric surface waves and the confined beam corresponding to Gauss-Hermite beam modes. In this letter, an experimental investigation of the mode structure and field profiles of several modes of a HDSBW resonator, Fig. 1 is reported.

II. SLAB BEAM MODES

The HDSBW uses two distinct waveguiding principles in conjunction with each other to guide electromagnetic waves. In the direction normal to the slab surface the guided waves should behave as surface waves of the slab guide; their energy largely confined to the interior and near the surface of the dielectric with the electric and magnetic field strengths exponentially tapering off into the air region. In the lateral

Manuscript received April 2, 1993. This work was supported in part by the U.S. Army Research Office through Grant DAAL03-89-G-0030.

S. Zeisberg, A. Schuenemann, G. P. Monahan, P. L. Heron, and M. B. Steer are with the High Frequency Electronics Laboratory, Department of Electrical and Computer Engineering, North Carolina State University, Raleigh, NC 27695-7911.

J. W. Mink is with the United States Army Research Office, P.O. Box 12211, Research Triangle Park, NC 27709-2211. F. K. Schwing is with CECOM, Attn. AMSEO-RD-C3-ST, Ft. Monmouth, NJ 07703-5203.

IEEE Log Number 9210806.

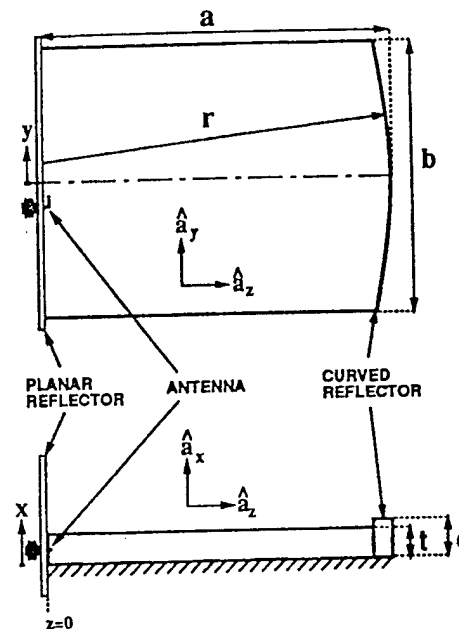

Fig. 1. Planar quasi-optical slab resonator: HDSBW resonator, the dielectric is Rexolite ($\epsilon_r = 2.57$, $\tan\delta = 0.0006$ at X-band), $a = 30.48$ cm, $b = 38.10$ cm, $r = 60.96$ cm, $t = 0.127$ cm.

direction the waves should behave as Gauss-Hermite beam modes which are reflected by the curved reflector. A HDSBW supports TE- and TM-slab beam modes, defined with respect to the direction of propagation. The mode families are TE_{mnq} and TM_{mnq} where m , n , and q are the mode indices in the normal (x), transverse (y) and longitudinal (z) directions. For the resonator of Fig. 1 with the L-shaped antenna parallel to the ground plane a large number of resonant responses were observed for different longitudinal and transverse mode numbers of the TE modes. In this case, weaker and lower Q TM mode responses were detectable. With this antenna orientation, TE modes are preferentially excited while the excitation of the TM modes is poor. With the L-shaped antenna rotated so that it was normal to the ground plane TM mode resonances were larger but the TE responses were weak compared with the parallel antenna orientation. The transverse order of the modes was determined by field profiling. The resonant frequencies of the observed TE modes are plotted in Fig. 2 with the L-shaped antenna parallel to the ground plane.

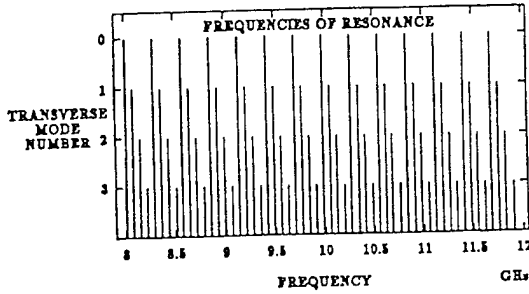

Fig. 2. Observed TE-mode resonant frequencies for various transverse modes.

The measured quality factor Q of the TE-mode resonances increases with frequency and peaks at a value of 2240 at 11.5 GHz. The published loss tangent of 0.0006 at X-band of the Rexolite dielectric [5] corresponds to a Q of 1667 in this frequency range. This is an upper limit on Q of the slab resonator and is modified by additional losses due to the grounded copper plane but with reduced dielectric losses as a part of the beam energy is guided outside the slab. The lateral dimension of the slab resonator was chosen to be three times the beam waist (between the $1/e$ field points) of the fundamental Gaussian beam mode at the lower limit of the frequency range, so as to minimize side-wall effects.

III. FREQUENCIES OF RESONANCE

The propagation constant, β_{nq} , of the TE_{0nq} resonant modes of the semi-confocal HDSBW resonator is [4, (27), (29)]

$$\beta_{nq} = \frac{1}{a} \left(q\pi + \left(n + \frac{1}{2} \right) \frac{\pi}{4} \right). \quad (1)$$

This is related to the resonant frequency of the TE_{0nq} mode by [6, (46)]

$$\sqrt{\beta^2 - \left(\frac{2\pi f}{c} \right)^2} \tan \left(d \sqrt{\epsilon_r \left(\frac{2\pi f}{c} \right)^2 - \beta^2} \right) = -\sqrt{\epsilon_r \left(\frac{2\pi f}{c} \right)^2 - \beta^2}. \quad (2)$$

These equations were numerically solved to obtain the TE_{0nq} -mode resonant frequencies f_{0nq} . Using a constant relative permittivity of 2.57 [5] for X-band results in a difference between measured and calculated resonant frequencies except in the center of the frequency range; apparently because the relative permittivity, ϵ_r , depends on frequency. The decrease of ϵ_r with increasing frequency [5] yields a relative error in the prediction of the frequencies of resonance of the HDSBW resonator of 0.18% (15 MHz) in the worst case, occurring at the lower limit of X-band.

IV. MODE PROFILE

The field profiles at resonance of the lower order transverse modes of the $q = 27$ family of the TE modes are depicted

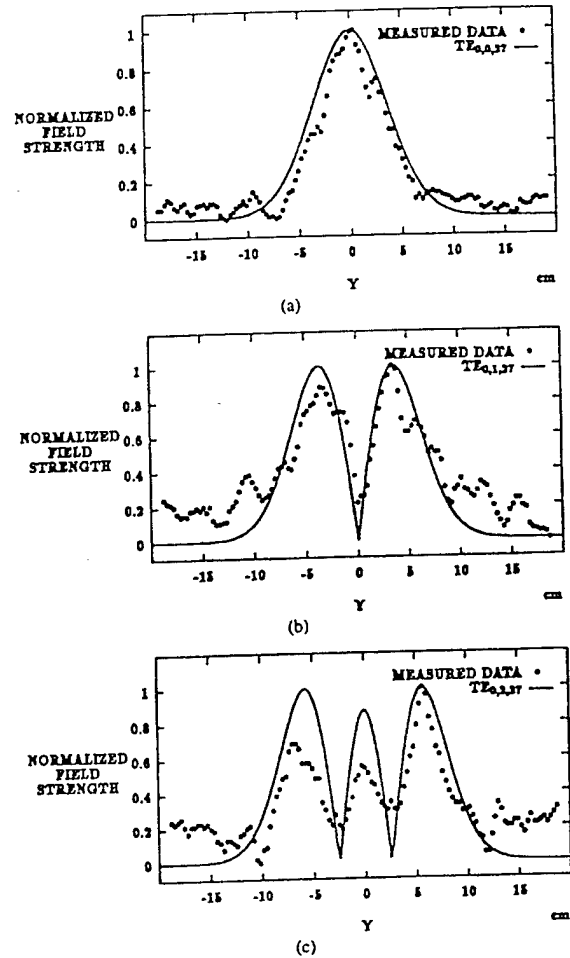

Fig. 3. Measured and calculated field profile of the lowest frequency TE modes (at resonance): (a) $TE_{0,0,27}$ (9.986 GHz), (b) $TE_{0,1,27}$ (10.056 GHz), (c) $TE_{0,2,27}$ (10.126 GHz).

in Fig. 3 superimposed on Gauss-Hermite functions. The measurements and calculations were performed at 14 cm from the planar reflector in the z -direction. The relative field strength was measured as the change in the reflection coefficient as a small pyramid of lossy material was moved across the surface of the slab. For the $TE_{0,0,27}$ and $TE_{0,2,27}$ modes, the antenna was placed at the $y = 0$ position as then these modes are efficiently excited. For the $TE_{0,1,27}$ mode a field null occurs at $y = 0$ and so the field profile of this mode was made with the antenna at $y = -2.54$ cm. The main lobes match the Gauss-Hermite functions and verify the assumed model of wave beam propagation predicted by Mink and Schwering [4]. The side lobes are assumed to result from radiation modes of the HDSBW and additional TM-modes. Another factor of influence is the finite size of the reflector resulting in diffractions at the edges and changing the border conditions of the field propagation. Putting tapered wedges at the slab edges did not change the field profiles significantly.

V. DISCUSSION AND CONCLUSION

The HDSBW bridges the gap between conventional dielectric wave-guides used at millimeter wave frequencies and the slab type dielectric waveguide used at optical frequencies. It appears that the behavior of the fields in a HDSBW resonator is similar to that in an open resonator. The major difference is that most of the energy in the fields is confined to the dielectric region. With an open cavity efficient and robust power combining is accomplished in three dimensions. In the planar slab resonator, power would be combined in two dimensions with the Q of the resonances less due to the inherent losses of the dielectric and conduction losses of the ground plane. Nevertheless the hybrid dielectric slab beam waveguide should be well suited as a transmission medium for the design of planar quasi-optical integrated circuits and devices operating in the millimeter-wave and submillimeter-wave regions. The HDSBW resonator should be the appropriate means for power combining in these regions

as lateral dimensions are relaxed in just one dimension and passive and active devices can be introduced by selectively metalizing the surface or, utilizing lamination, interior surfaces of the slab.

REFERENCES

- [1] J. W. Mink, "Quasi-optical power combining of solid-state millimeter-wave sources," *IEEE Trans. Microwave Theory Tech.*, vol. MTT-34, pp. 273-279, Feb. 1986.
- [2] P. F. Goldsmith, "Quasi-optical techniques," *Proc. IEEE*, vol. 80, pp. 1729-1747, Nov. 1992.
- [3] R. M. Weikle, II, M. Kim, J. B. Hacker, M. P. De Lisio, Z. B. Popović, and D. B. Rutledge, "Transistor oscillator and amplifier grids," *Proc. IEEE*, vol. 80, pp. 1800-1809, Nov. 1992.
- [4] J. W. Mink and F. K. Schwing, "A hybrid dielectric slab-beam waveguide for the sub-millimeter wave region," to be published in *IEEE Trans. Microwave Theory Techniques*, Oct. 1993.
- [5] R. S. Elliot, *An Introduction to Guided Waves and Microwave Circuits*. Englewood Cliffs, NJ: Prentice-Hall, 1993.
- [6] R. E. Collin, *Field Theory of Guided Waves*. New York: McGraw-Hill, 1960.

A Quasi-Optical Dielectric Slab Power Combiner with A Large Amplifier Array

H. S. Hwang, C. W. Hicks*, M. H. Steer, J. Harvey*, and J. W. Mink

Department of Electrical and Computer Engineering, North Carolina State University, Raleigh, NC 27695-7911

* U.S. Army Research Office, P.O. Box 12211, Research Triangle Park, NC 27709-2211

Abstract

A two-dimensional quasi-optical hybrid dielectric slab beammode waveguide (HDSBW) with a 5×4 MMIC amplifier array is demonstrated. Performance of this 2D concave-lens HDSBW system including amplifier gain and total system loss, input power vs output power and surface field patterns are presented. Methodology for the future planar quasi-optical (QO) power combiners.

I. Introduction

Several architectures employing solid-state devices have been developed for QO power combiners. Among them, the 2D HDSBW power combiner has the advantage of small size, light weight and perhaps more easily fabricated in monolithic technology. In our previous paper [2], a 4×1 MESFET amplifier array was located underneath the slab with a maximum amplifier gain and output power of 19.5 dB and 5 dBm, respectively. Even though the gain is high, the output power level is not enough for the practical applications of this system. A principle problem with this system is excessive loss. In this paper, the HDSBW with a large MMIC amplifier array shown in Fig. 1 (a) is investigated for higher output power, and excessive system loss is identified and substantially reduced. Measured data shows that this concave-lens HDSBW system has the maximum amplifier gain, system gain and output power of 30 dB, 14 dB and 14.68 dBm at 8.828 GHz, respectively.

II. System Description and Loss Mechanism

The HDSBW system with a 5×4 amplifier array underneath the slab is shown in Fig. 1 (a) with $d_1 = 15.6$ cm, $d_2 = 40$ cm and $d_3 = 15.4$ cm. The slab is 1.27 cm thick and 27.94 cm wide. The relative dielectric constant is $\epsilon_r = 2.55$ for the slab and is $\epsilon_{ant} = 10.5$ for the antenna substrate. The concave lens is an air region with a radius 30.48 cm, and is used for less beammode scattering loss (see [2]). The amplifier unit shown in Fig. 1 (b) has two Vivaldi antennas and sits in a metal carrier to amplify the guided TE beammodes. The amplifier unit employs two cascaded MMIC chips (Mini-Circuits ERA-1). The carrier not only stops the radiation of the antenna leaking through the antenna substrate, but also provides a good heat sink for the amplifier chips. As the antenna sitting inside a carrier, its S_{11} differs from that of the old taper antennas which were used in our previous work. Hence the variation of S_{11} of the antenna should be carefully considered again to ensure matching between the antenna and MMIC chip. By iteratively using the MoM method simulator developed by Nutson *et al.*, [1], the antenna was optimized for operation around 9 GHz as shown in Fig. 2 (a). The normalized $|S_{11}|$ of the

antenna-to-horn path for the system with and without a metal cover is shown in Fig. 2 (b).

For the system without the amplifiers, its passive system loss is about 5 ± 1 dB over the operation frequency range. As the system is with amplifier unbiased, the insertion loss due to the amplifiers is about 2.5 ± 1 dB. The total system loss can be obtained by adding the passive loss with the insertion loss. Through the experiment we have identified three major sources of loss, and each of which is (1) scattering loss into the open region above the slab; (2) fractional capture of power by the horn and non-optimum horn design; (3) discontinuity at the lens resulting in both reflective loss at the dielectric interface. In essence, discontinuities have a much greater effect on scattering in a system without a metal top than a system with a metal top. So the strategy was to use a parallel plates to reduce scattering.

III. Performance of the HDSBW Amplifier System

For the purpose of raising the output power level, more amplifier units are added into the slab system and they are arranged to be a 5×4 array. The area of this array is 12 cm wide and 30 cm long. The whole concave lens system is also covered by a 12-inch-wide metal plate. Since the flatness of the metal plate located above the system largely affected the input wave, E_{in} , and output wave, E_{amp} , of each amplifier unit, a heavy block was placed on this plate to adjust the flatness to tune the E_{in} so that all E_{amp} will have coherent output amplitudes and phases. In Fig. 3 (a), the amplifier gain and loss for the system with a "adjusted" metallic top is shown with the maximum amplifier gain of 30 dB at 8.828 GHz as $P_{in} = -3$ dBm. The output power vs frequency is shown in Fig. 3 (b) and the system gain is about 7.5 dB as $P_{in} = -3$ dBm. Note that the bandwidth of the positive system gain is 70 MHz, and this emphasizes that the system performance not only depends on the ability of the amplifier array but is also highly sensitive to the flatness of the plate.

The P_{out} vs P_{in} at 8.828 GHz is shown in Fig. 4 (a). The maximum output power is about 9 dBm as $P_{in} = -6$ dBm and $P_{in} = 10$ dBm, and the system gain ($P_{out} - P_{in}$) has a maximum value of 14 dB with $P_{in} = -6$ dBm. The system gain decreases with $P_{in} \geq -6$ dBm. The measured $|E_y|$ patterns are plotted in Fig. 4 (b). The profile of $|E_y|$ (Amp ON) is about 10 to 18 dB above that of $|E_y|$ (No Amp) for the $-1 \geq y \geq 9$ cm region. The amplified $|E_y|$ has a dip in the middle and looks like the second-order Gaussian beam mode. Since the horn aperture is from -4.5 cm to 4.5 cm, then only some part of the amplified energy is received. By counting the power outside the horn, an additional gain of 5.68 dB could be added to the output power, and the maximum P_{out} becomes 14.68 dBm. Comparing the output power of 5 dBm in [2], an improvement of 9.68 dB for the output power level has been successfully achieved.

IV. Conclusion

A 2D HDSBW amplifier system with a 5×4 MMIC amplifier array is demonstrated. The driving-point impedance and the energy transfer between antenna and the horn has been optimized and improved. System performance including the amplifier gain and system gain, system loss due to the lenses and amplifiers, the patterns of combined power, and output power level are discussed. This 5×4 MMIC amplifier system generates almost 10 times output power than that from the system with a 4×1 MESFET array.

References

- [1] T. W. Nuteson, M. H. Steer, K. Maishadham, J. W. Mink, and J. Harvey, "Electromagnetic modeling of finite grid structures in quasi-optical system," *IEEE MTT-S Int. Microwave Symp. Dig.*, pp. 1251-1254, June 1996.
- [2] H. Hwang, T. W. Nuteson, M. B. Steer, J. W. Mink, J. Harvey, and A. Paolletta, "Two-dimensional quasi-optical power combining system performance and component design," *IEEE MTT-S Int. Microwave Symp. Dig.*, pp. 927-930, June 1996.

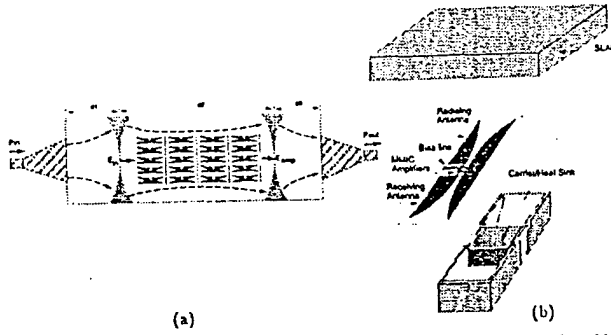

Figure 1: (a) A concave-lens HDSBW with a 5x4 amplifier array underneath a thin slab. (b) An antenna unit sits inside a carrier underneath the slab system.

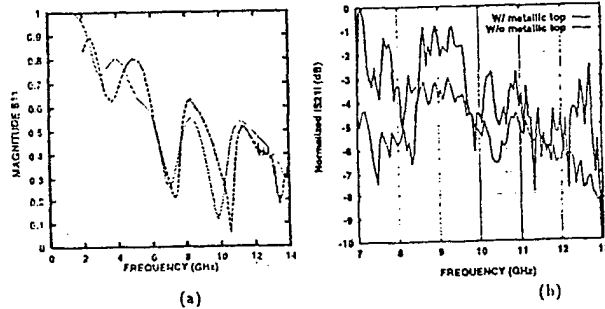

Figure 2: (a) Measured (dashed line) and simulated (solid line) S_{11} for the Vivaldi antenna. (b) Normalized $|S_{21}|$ between a single Vivaldi antenna and the horn.

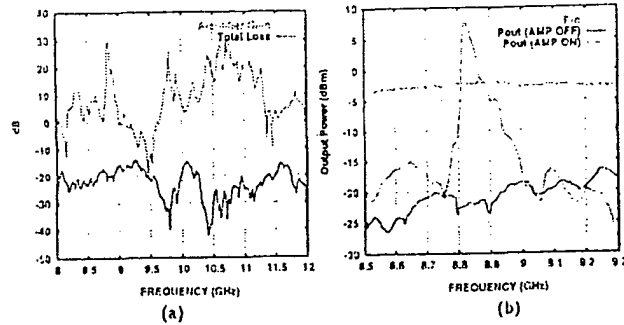

Figure 3: (a) Amplifier gain and total loss for the system with a 5x4 array. (b) P_{out} vs frequency for the system with a 5x4 array.

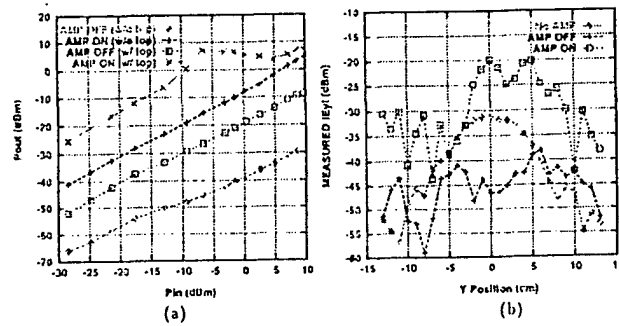

Figure 4: (a) P_{in} vs P_{out} at 8.828 GHz. (b) Measured $|E_y|$ patterns for the system with a 5x4 array working at 8.828 GHz.

Spatial Power Combining for Two Dimensional Structures

J.W. Mink, H.-S. Hwang, C.W. Hicks[†], T.W. Nuteson, M.B. Steer, and J. Harvey^{*}
 Electronics Research Laboratory, Department of Electrical and Computer Engineering,
 North Carolina State University, Raleigh, NC 27695-7911
 919-515-5090 (office) 919-515-5601 (Fax)

[†]Naval Air Warfare Center Aircraft Division, Patuxent River MD 20670

^{*}United States Army Research Office, PO Box 12211, Research Triangle Park, NC 27709

Abstract-A hybrid dielectric slab-beam waveguide is suitable for the design of planar quasi-optical integrated circuits and devices. In this paper a 2-D quasi-optical power-combining system with convex and concave lenses was investigated. The system employs an active E-plane amplifier array consisting of Vivaldi-type antennas with MESFET and MMIC devices. The system was tested by switching the amplifier bias off and on while measuring the power with an E-plane horn. Tests were performed with a single MMIC amplifier and a 4 x 1 MESFET amplifier array. The amplifier array generated 11 dB and 4.5 dB of amplifier and system gain respectively at 7.12 GHz, and the single MMIC Vivaldi-type antenna produced 24 dB of amplifier gain at 8.4 GHz.

I. INTRODUCTION

Spatial power combining has emerged as a promising technique for power combining at millimeter and sub-millimeter wave frequencies. One embodiment of spatial power combining is quasi-optical power combining based on the principle that radiated fields produced by an array of solid state active devices may be combined. The fields are combined utilizing wavebeam principles in free space or dielectric material to generate reliable power. Periodic refocusing of the beam is accomplished by the use of optical lenses to combine the power in a single paraxial mode. The large transverse and longitudinal dimensions of the quasi-optical structures provide significant area for the active MMIC devices and control components to be included within the structure. The most mature quasi-optical structures include grid amplifiers and resonant cavities where the power is combined in three-dimensional space (3-D) [1, 2]. However, two-dimensional (2-D) technology offers an alternative approach with significant advantages. Mink and Schwering [4] proposed a 2-D hybrid dielectric slab-beam waveguide (HDSBW) which is more amenable to photolithographic definition and fabrication, and is more compatible with the MMIC technology [5,6]. The 2-D HDSBW has reduced size and weight, and improved heat removal capability which results in lower costs.

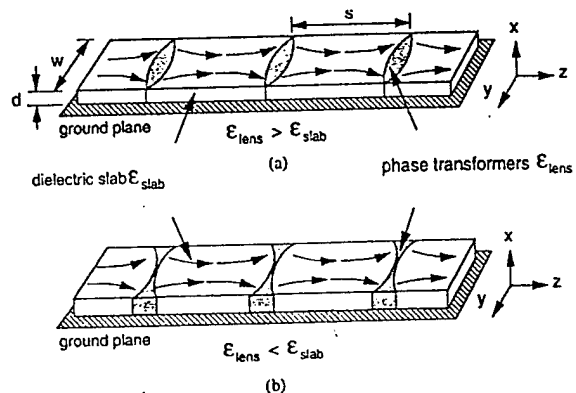

Figure 1: Passive 2D quasi-optical power combining system (a) convex lenses and (b) concave lenses.

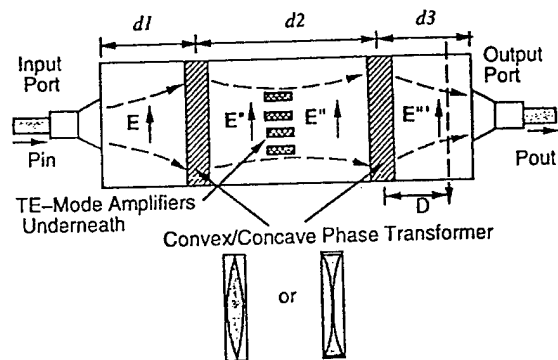

Figure 2: The HDSBW system with convex/concave lenses and 4 x 1 MESFET amplifier array.

IV. PRINCIPLES OF OPERATION

The HDSBW uses two distinct waveguiding principles to guide the electromagnetic wave [5,7]. The input energy travels in a Gaussian-Hermite mode along the slab waveguide. In the x-direction, the field distribution is that of a surface-wave mode of the grounded dielectric slab;

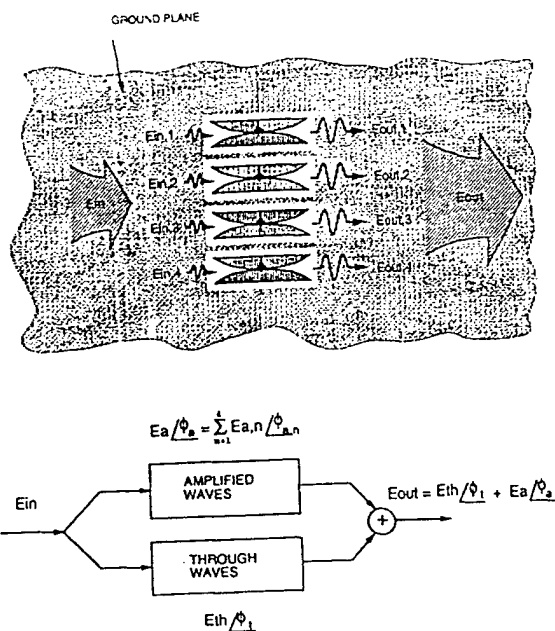

Figure 3: Wave model for 2D power combining

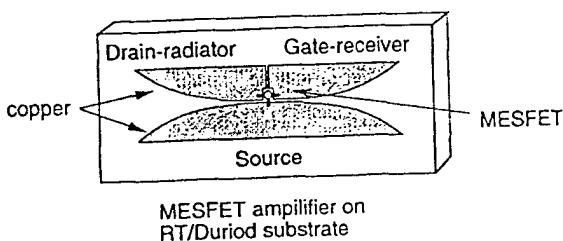

Figure 4: MESFET Vivaldi amplifier

the wave is guided by total reflection at the air-to-dielectric interface and parameters are adjusted such that energy is transmitted primarily within the dielectric. In the y -direction the field distribution is that of a wave beammode (Gauss-hermite) which is guided by the lenses through periodic reconstitution of the cross sectional phase distribution. The guided modes can be either TE or TM polarized with respect to the direction of propagation whose period is the spacing of the lenses. Figure 1 shows the passive HDSBW employing two examples of periodic refocusing. Figure 1(a) shows convex lenses that are utilized to periodically reset the wavebeam phase and Figure 1(b) displays this principle by utilizing concave lenses.

The principle employed here to obtain signal amplification is similar to that of a traveling wave amplifier. An array of active elements located underneath the dielectric slab is placed in the path of the wavebeam as shown in Figure 2. Each active element consists of a pair of back-to-back Vivaldi antennas with an amplifier inserted between the

two antennas. Part of the incident signal, the thru wave, passes through the dielectric slab undisturbed. The remaining signal is amplified by the array. The first Vivaldi antenna couples energy from the incident traveling wavebeam, and the second Vivaldi antenna reinserts the amplified signal back into the traveling wave beam. Maximum coupling to the array occurs when the energy from the first lens focuses energy to the input of the Vivaldi antennas. The signal is amplified by the MESFETs and is coupled by the output Vivaldi antennas to the traveling wavebeam where it combines in phase with the through signal as shown in Figure 3. Consequently, a growing traveling wavebeam mode is established within the guiding structure resulting in increased output power.

III. SYSTEM CONFIGURATION

The system configuration for the HDSBW shown in Figure 2 consists of rectangular dielectric slab made of Rexolite ($\epsilon_r = 2.57$, $\tan\delta = 0.0006$) placed on a conducting ground plane. Two concave cylindrical lenses made of Macor ($\epsilon_r = 5.9$, $\tan\delta = 0.0006$) with focal lengths equal to 28.54 cm were inserted between the dielectric slab. The dielectric slab dimensions length ($d_1 + d_2 + d_3$), width (w) and thickness (d) were 62 cm, 27.94 cm and 1.27 cm respectively. The Vivaldi antenna MESFET amplifiers were located underneath the dielectric slab in the ground plane. Each Vivaldi antenna was fabricated using RT/Duroid 6010 substrate ($\epsilon_r = 10.2$, $\tan\delta = 0.0028$) with the dimensions 6.5 cm x 1.5 cm. Two E-plane horns were designed and fabricated that efficiently launch and receive the required wavebeam.

V. EXPERIMENTAL RESULTS

Two tests were performed, the first utilized a 4 x 1 MESFET Vivaldi amplifier array as shown in Figure 2, and the second employed a single MMIC Vivaldi amplifier located under the dielectric slab (see Figure 6). A measure of the relative energy coupled to the amplifier array was obtained by switching the amplifier bias levels off and on while measuring the output power, P_{out} . The system performance for the active Vivaldi amplifier array was determined by the system gain and amplifier gain. This provided an indication of the incident signal that passes through the dielectric as an undisturbed traveling wave.

Figure 5 shows the total system performance of the MESFET amplifier array at 7.12 GHz using concave lenses. A plot of P_{in} versus P_{out} is indicated by AMP OFF and AMP ON respectively. The input power, P_{in} varied from -45 dBm to +10 dBm in +5 dBm increments. The power ratio between P_{out} and P_{in} was relatively constant for P_{in} less than -15 dBm, however P_{out} reached the

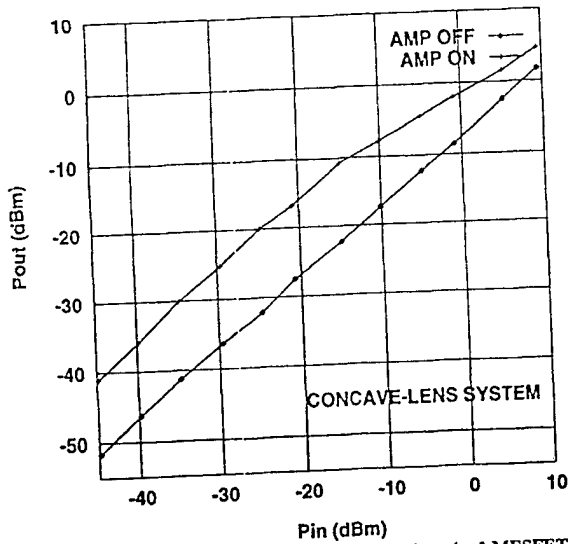

Figure 5: Input and output power of the concave-lens 4 x 1 MESFET array.

saturation condition with P_{in} greater than -15 dBm. The maximum system gain of 4.5 dB occurred at $P_{in} = -15$ dBm while the amplifier gain on to off measured was 11 dB.

The second test was performed with a cascaded pair of MMIC amplifiers in order to achieve higher power levels. In Figure 6, the amplifier gain of the Vivaldi amplifier was determined by placing a metal screen transverse to the Vivaldi structure. The Vivaldi amplifier and the metal wall were placed 5.5 cm and 9.7 cm respectively from the input horn. A concave lens was placed in the middle of a 40 cm dielectric slab. The slit in the metal wall allowed for only input power of the amplifier and the amplified energy to go through the system so that the amplifier gain could be measured. The amplifier gain shown in Figure 7 was determined by switching the bias voltage on and off, while measuring the power difference detected by the receiving horn. The amplifier gain indicates that more than 10 dB of gain was produced from 7 GHz to 10.4 GHz with a maximum gain of 24 dB at 8.4 GHz.

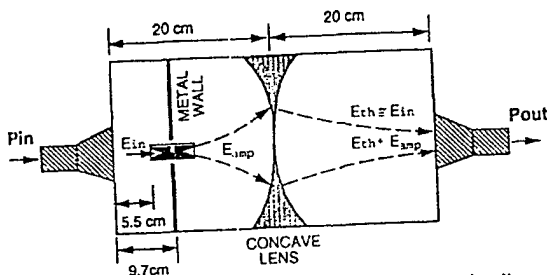

Figure 6: The concave-lens system configuration for a unit cell amplifier

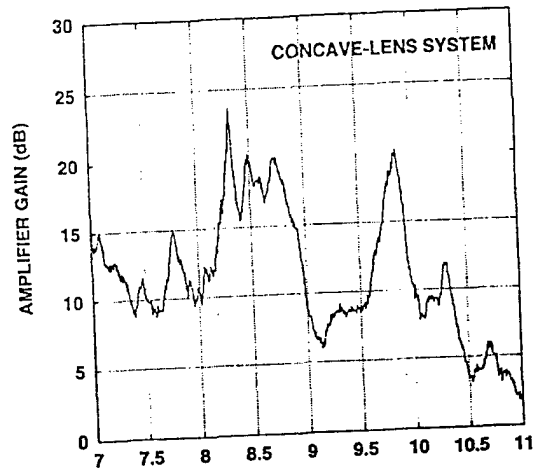

Figure 7: Amplifier gain for a unit cell amplifier with cascaded MMIC chips.

VI. CONCLUSIONS

A 2-D HDSBW spatial power combining system suitable for planar integrated circuits and devices has been presented. A system using concave lenses and Vivaldi-type antennas with MESFET and MMIC devices has been demonstrated. The 4 x 1 MESFET amplifier array produced 11 dB of amplifier gain and 4.5 dB of system gain at 8.4 GHz. Operating at 7.12 GHz, a single MMIC amplifier produced 24 dB of amplifier gain. By combining more MMIC instead of MESFETs greater power can be achieved. This paper shows that 2D spatial system is suitable for planar MMIC technology.

ACKNOWLEDGMENTS

The work was support by the U.S. Army Research Office in Research Triangle Park, NC and the Naval Air Warfare Center Aircraft Division, RF Sensor Branch, Code 4.5.5.5, in Patuxent River, MD.

REFERENCES

- [1] J.W. Mink, "Quasioptical power combining of solid-state millimeter-wave sources," *IEEE Trans. Microwave Theory Tech.*, vol. 34, pp. 273-279, Feb. 1986.
- [2] Z.B. Popovic, R. M. Weilke, M. Kim and D.B Rutledge, "A 100-MESFET planar grid oscillator," *IEEE Trans. on Microwave Theory and Techniques*, vol. MTT-39, pp. 193-200, Feb. 1991.
- [3] H. Hwang, G.P. Monahan, M.B. Steer, J.W. Mink, J. Harvey, A. Paolletta, and F. K. Schvering, "A dielectric slab waveguide with four planar power amplifiers," in *IEEE MTT-S Int. Microwave Symp. Dig.*, May 1995, pp. 921-924.
- [4] J.W. Mink and F.K. Schvering, "A hybrid dielectric slab-beam waveguide for the millimeter wave region," *IEEE Trans. Microwave Theory Tech.*, vol. 41, pp. 1720-1729, Oct. 1993.

- [5] F. Poegel, S. Irrgang, S. Zeisberg, A. Schuenemann, G. P. Monahan, H. Hwang, M. B. Steer, J. W. Mink, F. K. Schwering, A. Paollela and J. Harvey. "Demonstration of an oscillating quasi-optical slab power combiner." in IEEE MTT-S Int. Microwave Symp. Dig., May 1995, pp. 917-920.
- [6] A. R. Perkons and Tatsuo Itoh, "A 10-element active lens amplifier on a dielectric slab," IEEE MTT-S Int. Microwave Symp. Dig., pp. 119-1122, June 1996.
- [7] R. A. York, Z. B. Popovic. Active and quasi-optical arrays for solid-state power combining. John Wiley & Sons, Inc. 1997, pp. 277-292.

Quasi-optical Power Combining Techniques for Dielectric Substrates

H. Hwang, T. W. Nuteson, M. B. Steer, and J. W. Mink
Electronics Research Laboratory, Department of Electrical & Computer Engineering
North Carolina State University, Raleigh, NC 27695-7911

J. Harvey
United States Army Research Office, PO Box 12211, Research Triangle Park, NC 27709

A. Paoletta
Microwave & Lightwave Components Division, AMSRL-EP-MA
United States Army Research Laboratory, NJ 07703

1 Introduction

Several quasi-optical systems have been reported, including grid oscillators [1] and amplifiers [2], resonant cavity oscillators [3,4], microstrip-based rotator arrays [5], and dielectric slab beam waveguides (DSBW) [6] for power combining. The dielectric slab system described here has the advantage of being two-dimensional and is thus more amenable to photolithographic reproduction than the conventional open quasi-optical power combining structures. Previous investigations of the quasi-optical dielectric slab cavity and waveguide [7, 8] demonstrated the suitability of this structure for the integration of quasi-optical power combining with MMIC technology.

A complete DSBW quasi-optical system, as shown in Fig. 1, could consist of the following: a source, active or injection, [7], an amplifier array [8], triplers, and a leaky wave antenna which would be used for steering the energy out of the system. Between each of the stages lenses are used to focus the guided waves for optimal field concentration on the elements in the system. In this work we present the amplifier array stage using both convex and concave lenses as shown in Fig. 2. The DSBW amplifier system incorporates four MESFET amplifiers and two thin convex/concave lenses. The waveguide system was adjusted with the transistors turned off so that the guided waves are focused near the aperture of the receiving horn. The dielectric slab is Rexolite ($\epsilon = 2.57$, $\tan\delta = 0.0006$ at X-band), and it is 27.94 cm wide, 62 cm long, and 1.27 cm thick. The convex lenses are fabricated from Macor ($\epsilon = 5.9$, $\tan\delta = 0.0025$ at 100 kHz) with a radius of 30.48 cm, and the focal length, f , is 28.54 cm. The concave lenses are air ($\epsilon = 1$) with a radius of 30.48 cm, and the focal length, f , is 40.4 cm. The aperture width of both horn antennas is 9 cm, designed to be wide enough to catch most of the amplified power. Energy emitted from the input radiator propagates in a quasi-optical TE Gaussian mode in the dielectric slab waveguide, and is focused by the first lens in the middle area of the slab. This system is designed so that the amplifier unit cells are within the beam waist (the $1/e$ field points).

The amplifier unit cells are 7 cm x 1.5 cm and employ HP ATF-10235 MESFETs. This design was derived from the active slot-line notch antenna by Leverich, et al. [9]. An amplifier unit includes two end-fire Vivaldi antenna tapers which are gate-receiver and drain-radiator, and is specifically designed to eliminate surface-of-slab to ground-plane resonance. The advantage of locating the amplifiers on the ground plane is that it reduces beam-mode perturbation, scattering losses, and reflection of the input energy due to the amplifier structure. These are problems with amplifiers mounted on the surface of the slab [8] and in the more conventional grid system.

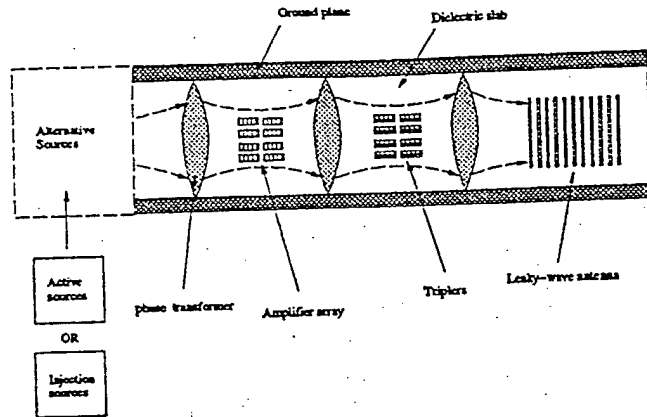

Figure 1: A dielectric slab beam waveguide system.

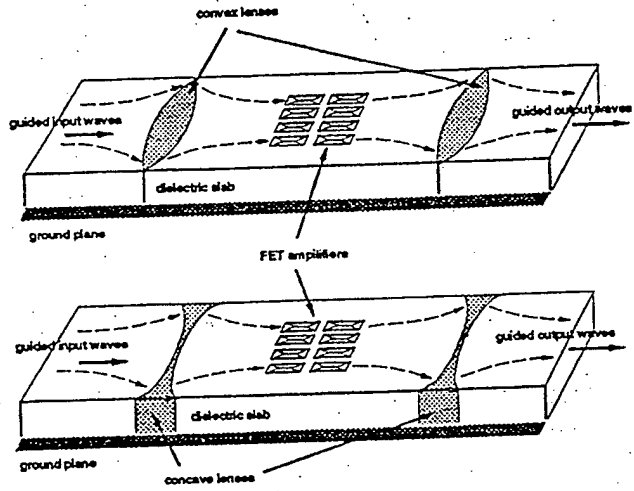

Figure 2: Amplifier array stage with convex and concave lenses.

2 Experimental Results and Discussions

Passive measurements were made on the DSBW system with no amplifiers present comparing the convex and concave lenses. The concave lens system has less loss than the convex lens system as shown in Fig. 3. Fig. 4 shows the electric field measured at a frequency of 7.28 GHz for both the convex and concave lenses. This measurement estimates the loss due to the lenses where the convex lens loss is approximately -3.66 dB and the concave lens loss is approximately -1.18 dB. This loss estimation is obtained by integrating the areas under the E -field patterns before and after lenses. In Fig. 5, the insertion loss is given for both cases where the convex lens system is showing lower loss. The reason for this is that the input wave scattered by the amplifier array goes into the air more easily for the concave lens system than for the convex lens system.

The amplifier gain, computed as the ratio between $P_{out}(\text{Amp ON})$ and $P_{out}(\text{Amp OFF})$, is shown in Fig. 6 for both concave and convex lens systems. The amplifier gain is 16 dB for the concave case and 14 dB for the convex case as P_{in} is -12.4 dbm. This implies that the concave lens system

has better performance than the convex lens system. In these measurements the four MESFET amplifiers were placed on the ground plane underneath the Rexolite.

The system gain (defined as P_{out}/P_{in}) is shown in Fig. 7 for both the concave and convex systems with and without a metallic top cover. For the concave case the system gain is approximately 7.7 dB with and without the metallic top cover. For the convex case the metallic cover gives a system gain of about 6 dB and without the cover 4 dB. The reason that there is a difference in the convex system gain with and without the cover is because the passive scattering loss for the convex lens system is higher than for concave lens system. Therefore, using a metallic cover can save more scattering energy for convex lens system.

3 Conclusions

We have demonstrated quasi-optical power combining in a dielectric substrate with the amplifier array located on the ground plane for both a concave and convex lens system. The overall performance of the concave lens system was better than the convex lens system including passive system gain, amplifier gain, and active system gain.

Acknowledgment

This work was supported in part by the U.S. Army Research Office through grant DAAL03-89-G-0030.

References

- [1] J. B. Hacker, M. P. de Lisio, M. Kim, C.-M. Liu, S.-J. Li, S. W. Wedge, and D. B. Rutledge, "A 10-watt X-band grid oscillator," *IEEE MTT-S Int. Microwave Symp. Dig.*, pp. 823-826, May 1994.
- [2] Z. B. Popovic, R. M. Weikle II, M. Kim, and D. B. Rutledge, "A 100-MESFET planar grid oscillator," *IEEE Trans. Microwave Theory Tech.*, vol. MTT-39, pp. 193-200, Feb. 1991.
- [3] J. W. Mink, "Quasi-optical power combining of solid-state millimeter-wave sources," *IEEE Trans. on Microwave Theory and Techniques*, vol. MTT-34, pp. 273-279, Feb. 1986.
- [4] P. L. Heron, G. P. Monahan, J. W. Mink, F. K. Schwing, and M. B. Steer, "Impedance matrix of an antenna array in a quasi-optical resonator," *IEEE Trans. Microwave Theory Tech.*, vol. MTT-41, pp. 1816-1826, Oct. 1993.
- [5] N. J. Koliass and R. C. Compton, "A microstrip-based quasi-optical polarization rotator array," *IEEE MTT-S Int. Microwave Symp. Dig.*, pp. 773-776, May 1995.
- [6] J. W. Mink and F. K. Schwing, "A hybrid dielectric slab-beam waveguide for the sub-millimeter wave region," *IEEE Trans. Microwave Theory Tech.*, vol. MTT-41, pp. 1720-1729, Oct. 1993.
- [7] F. Poegel, S. Irrgang, S. Zeisberg, A. Schuenemann, G. P. Monahan, H. Hwang, M. B. Steer, J. W. Mink, F. K. Schwing, A. Paolletta, and J. Harvey, "Demonstration of an oscillating quasi-optical slab power combiner," *IEEE MTT-S Int. Microwave Symp. Dig.*, pp. 917-920, May 1995.
- [8] H. Hwang, G. P. Monahan, M. B. Steer, J. W. Mink, J. Harvey, A. Paolletta, and F. K. Schwing, "A dielectric slab waveguide with four planar power amplifiers," *IEEE MTT-S Int. Microwave Symp. Dig.*, pp. 921-924, May 1995.
- [9] W. K. Leverich, X.-D. Wu, and K. Chang, "FET active slotline notch antenna for quasi-optical power combining," *IEEE Trans. Microwave Theory Tech.*, vol. MTT-41, pp. 1515-1517, Sept. 1993.

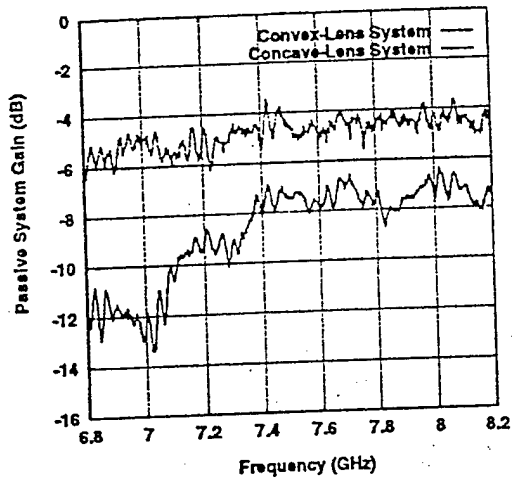

Figure 3: Passive system gain for convex-lens and concave-lens systems.

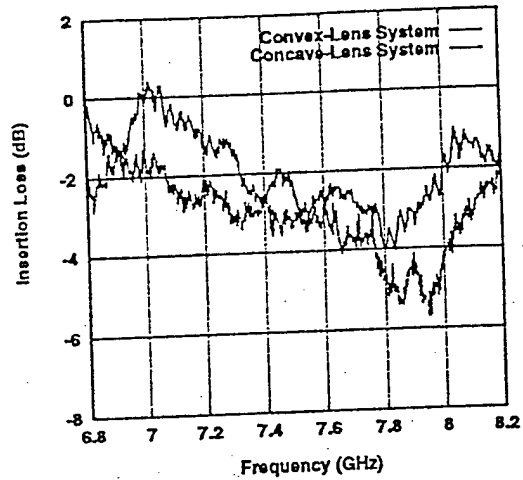

Figure 5: Insertion loss of convex-lens and concave-lens systems.

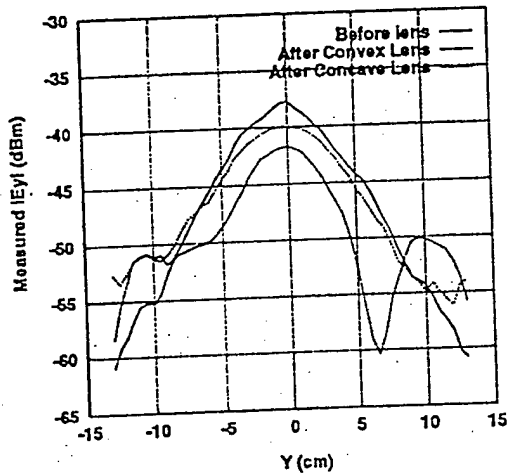

Figure 4: $|E_y|$ distributions before and after lenses.

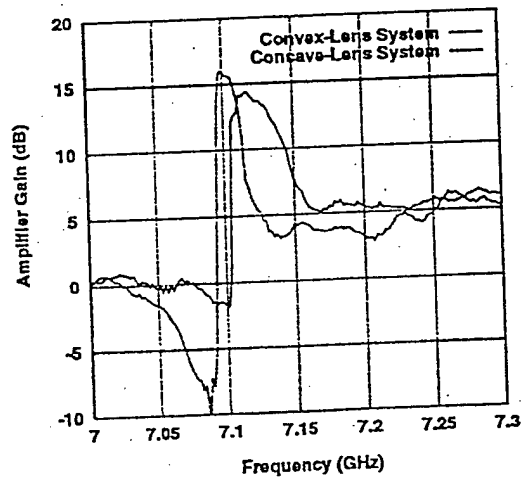

Figure 6: Amplifier gain in convex-lens and concave-lens systems.

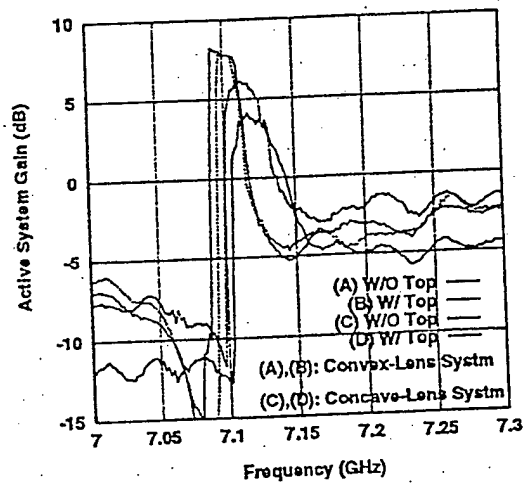

Figure 7: Active system gain for convex-lens and concave-lens systems.

QUASI-OPTICAL POWER COMBINING IN A DIELECTRIC SUBSTRATE

H. Hwang[†], T. W. Nuteson[†], M. B. Steer[†], J. W. Mink[†], J. Harvey[◇], and A. Paolletta[□]

[†] Electronics Research Laboratory, Department of Electrical and Computer Engineering, North Carolina State University, Raleigh, NC 27695-7911

[◇] United States Army Research Office, PO Box 12211, Research Triangle Park, NC 27709

[□] Microwave & Lightwave Components Division, AMSRL-EP-MA, US Army Research Laboratory, NJ 07703

Abstract. This paper presents a quasi-optical MESFET-based dielectric slab waveguide with an amplifier array. Up to 19 dB amplifier gain and 9.5 dB system gain is obtained at 7.38 GHz. Measurements of amplifier and system gain, $|S_{21}|$, output power vs. input power and transverse power distribution are presented.

1. Introduction

Several quasi-optical structures have been reported, including wave beam type [1], grid type [2], microstrip coupling type [3], and dielectric slab beam waveguide type (DSBW) [4] for power combining. The dielectric slab system has the advantage of being two-dimensional and is thus more amenable to photolithographic reproduction than the conventional open quasi-optical power combining structures. Previous investigations of the quasi-optical dielectric slab cavity and waveguide [5], [6] demonstrated the suitability of this structure for the integration of quasi-optical power combining MMIC technology. In this work, the amplifier arrays are located on the ground plane to reduce perturbation and scattering loss of the beam-modes. Measurements of amplifier gain and system gain, output power vs. input power and transverse electric field distribution are presented. At 7.38 GHz, amplifier gain and system gain reach 19 dB and 9.5 dB, respectively.

2. Dielectric Slab Power Combining System

The dielectric slab waveguide amplifier system incorporates four MESFET amplifiers and two thin convex lenses as shown in Fig. 1. Detail of the active region is shown in Fig. 2. The waveguide system was adjusted with the transistors turned off so that the guided waves are focused near the aperture of the receiving horn ($d_1 = 12$ cm, $d_2 = 44$ cm, $d_3 = 16$ cm). The dielectric slab is Rexolite ($\epsilon = 2.57$, $\tan\delta = 0.0006$

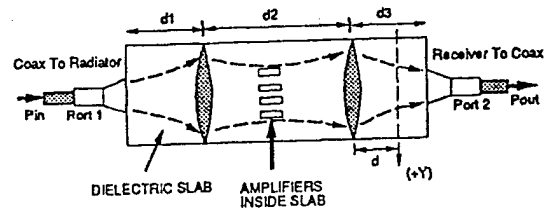

Figure 1: Dielectric slab waveguide system with MESFET amplifiers inside.

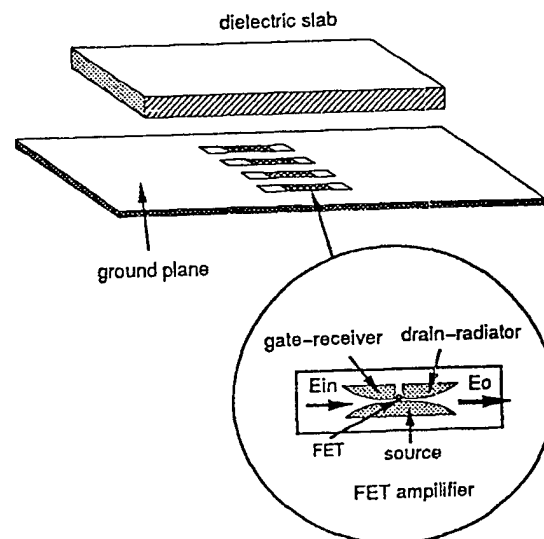

Figure 2: Amplifier array under dielectric slab waveguide.

at X-band), and it is 27.94 cm wide, 62 cm long, and 1.27 cm thick. The lenses are fabricated from Macor ($\epsilon = 5.9$, $\tan\delta = 0.0025$ at 100 kHz) with a radius of 30.48 cm, and the focal length, f , is 28.54 cm. The aperture width of both horn antennas is 9 cm, designed to be wide enough to catch most of the amplified power. Energy emitted from the input radiator propagates in a quasi-optical TE Gaussian mode in the dielectric slab waveguide, and is focused by the first lens in the middle area of the slab. This system is designed so that the amplifier unit cells are within the beam waist (the $1/e$ field points).

The amplifier unit cells are 7 cm x 1.5 cm and employ HP ATF-10235 MESFETs. This design was derived from the active slotline notch antenna by Leverich, et al. [7]. An amplifier unit includes two end-fire Vivaldi antenna tapers which are gate-receiver and drain-radiator, and is specifically designed to eliminate surface-of-slab to ground-plane resonance. The advantage of locating the amplifiers on the ground plane is that it reduces beammode perturbation, scattering losses, and reflection of the input energy due to the amplifier structure. These are problems with amplifiers mounted on the surface of the slab [6] and in the more conventional grid system.

3. Experimental Results and Discussions

The amplifier arrays were located at two locations, thus receiving different input power distributions. Figs. 3 and 4 show the amplifier gains with system input powers of -16 dBm, -13 dBm and -10 dBm. The amplifier gains are obtained by taking the ratio of the measured $|S_{21}|$ when the amplifiers are with and without bias. The highest amplifier gain is 19 dB in location 1 with a system input power -16 dBm. This amplifier gain can compensate the insertion loss due to the beammode energy scattered by the amplifiers.

In Fig. 5, the system loss and insertion loss are shown. The system loss includes beammode scattering by the lenses, and the horn radiation into the air. The insertion loss is due to beammode perturbation by the amplifier structure. In the frequency range of operation, the system loss is 9-10 dB when the system is without amplifiers, and the insertion loss is 2.5 dB due to the amplifiers inserted into the system.

After amplification, the guided waves spread out wider than horn aperture (see Fig. 9), and a small proportion of the amplified energy is captured by the receiving horn. As indicated in Fig. 6, the lenses do serve to focus energy to the receiving horn in spite of the scattering losses they induce.

Fig. 7 shows the system output power P_{out} vs. input power P_{in} when the amplifiers were with and without bias. The amplifier gain is the the difference

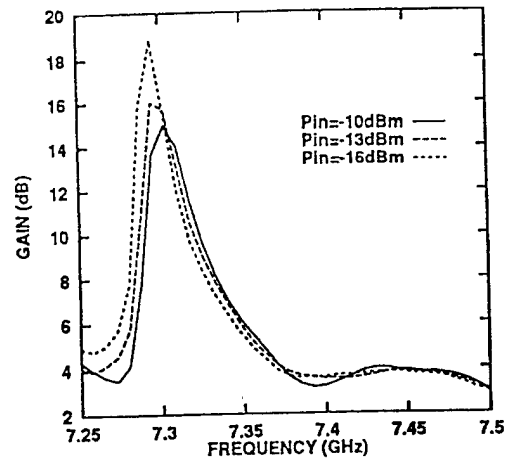

Figure 3: Amplifier gain for location 1. This location is 22cm away from the second lens.

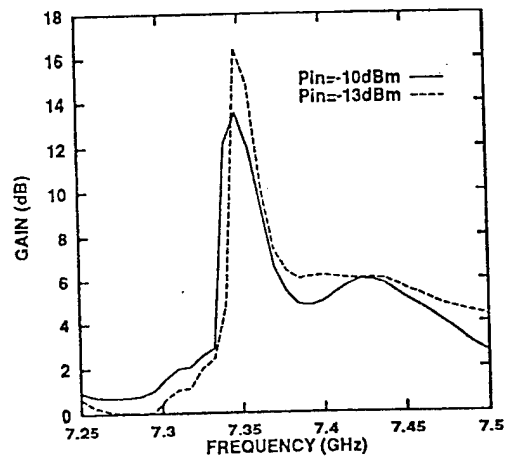

Figure 4: Amplifier gain for location 2. This location is 18cm away from the second lens.

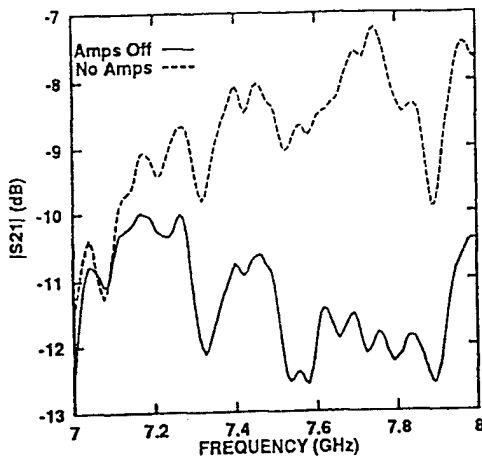

Figure 5: $|S_{21}|$ of the dielectric slab with/without amplifiers. The insertion loss of the unit cells alone is the difference between these two $|S_{21}|$ curves. This loss is believed to be due to field scattering.

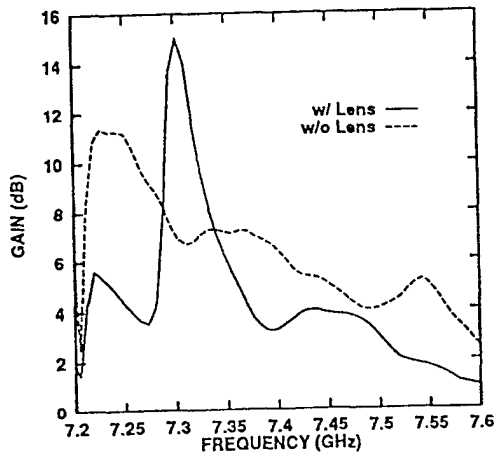

Figure 6: Comparison of amplifier gain with/without lenses.

between $P_{out}(\text{Amp ON})$ and $P_{out}(\text{Amp OFF})$. The system power gain is obtained by subtracting P_{in} from $P_{out}(\text{Amp ON})$. When $P_{out} = -16$ dBm, system power gain and amplifier gain are 9.5 dB and 19 dB, respectively. Note that the P_{out} does not saturate. This is a characteristic of the quasi-optical DSBW amplifier. When the the amplifier cells saturate, the excess input power continues to propagate in the slab. The power added efficiency (PAE) of this system is 3.35%. However, we need to count the scattering loss from the second lens, which is about 3.5 dB. Therefore, the PAE is about 7.5%.

The system gain (defined as P_{out}/P_{in}) is shown in Fig. 8 with $P_{in} = 10$ dBm. The E-field distribution measured at $d = 13$ cm is shown in Fig. 9. Comparing the field distributions for amplifiers without biases and for no amplifiers inside the slab, we find that the $|E_y|$ decreases about 2 to 4 dB due to the insertion of the amplifier unit cells in the $-5 \text{ cm} < y < 5 \text{ cm}$ region. Analysis indicates that only 66% of the amplified energy is captured by the receiving horn. Considering 37% of amplified energy is not received, the power added efficiency should be 11.2%.

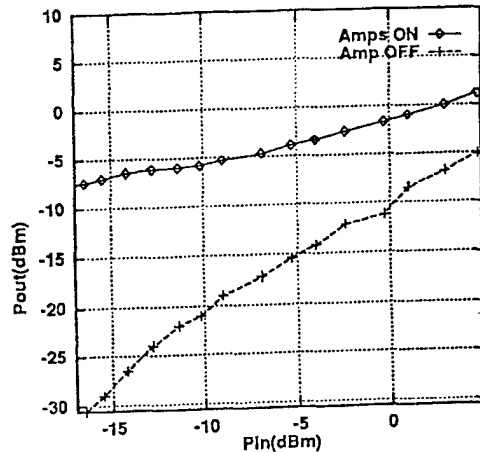

Figure 7: P_{out} vs P_{in} as amplifiers with/without bias

4. Conclusions

We have demonstrated quasi-optical power combining in a dielectric substrate with amplifiers located on ground plane. The maximum amplifier gain and system gain reach 19 dB and 9.5 dB, respectively, at 7.38 GHz.

Acknowledgment

This work was supported in part by the U.S. Army Research Office through grant DAAL03-89-G-0030.

We also thank R. Walter, A. Schaumke and K. Kojucharoff for their technical support in the early stages of this project.

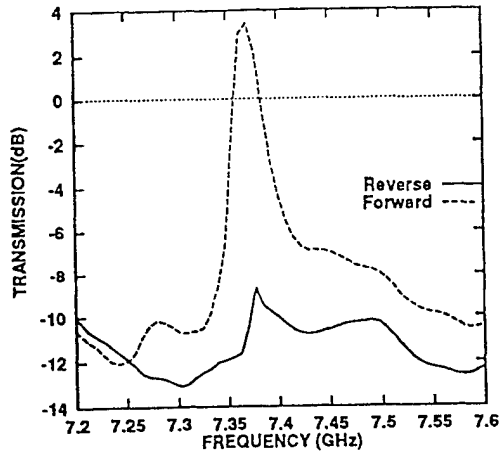

Figure 8: Transmission gain for the slab as amplifier with bias

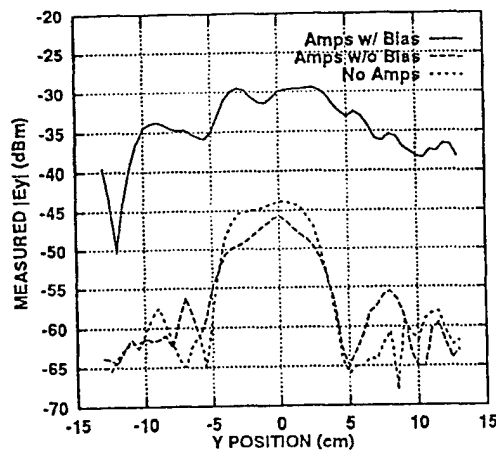

Figure 9: $|E_v|$ pattern on the top surface of slab. This pattern is measured at 7.38GHz with $P_{in} = 10$ dBm

References

- [1] J. W. Mink, "Quasi-optical power combining of solid-state millimeter-wave sources," *IEEE Trans. on Microwave Theory and Techniques*, vol. MTT-34, pp. 273-279, Feb. 1986.
- [2] Z. B. Popović, R. M. Weilke, M. Kim, and D. B. Rutledge, "A 100-MESFET planar grid oscillator," *IEEE Trans. Microwave Theory Tech.*, vol. MTT-39, pp. 193-200, Feb. 1991.
- [3] N. J. Koliass and R. C. Compton, "A microstrip-based quasi-optical polarization rotator array," *IEEE MTT-S Int. Microwave Symp. Dig.*, pp. 773-776, May 1995.
- [4] J. W. Mink and F. K. Schwing, "A hybrid dielectric slab-beam waveguide for the sub-millimeter wave region," *IEEE Trans. Microwave Theory Tech.*, vol. MTT-41, pp. 1720-1729, Oct. 1993.
- [5] F. Poegel, S. Irrgang, S. Zeisberg, A. Schuene-mann, G. P. Monahan, H. Hwang, M. B. Steer, J. W. Mink, F. K. Schwing, A. Paolletta, and J. Harvey, "Demonstration of an oscillating quasi-optical slab power combiner," *IEEE MTT-S Int. Microwave Symp. Dig.*, pp. 917-920, May 1995.
- [6] H. Hwang, G. P. Monahan, M. B. Steer, J. W. Mink, J. Harvey, A. Paolletta, and F. K. Schwing, "A dielectric slab waveguide with four planar power amplifiers," *IEEE MTT-S Int. Microwave Symp. Dig.*, pp. 921-924, May 1995.
- [7] W. K. Leverich, X.-D. Wu, and K. Chang, "FET active slotline notch antenna for quasi-optical power combining," *IEEE Trans. Microwave Theory Tech.*, vol. MTT-41, pp. 1515-1517, Sept. 1993.

A Slab-Based Quasi-Optical Power Combining System

H.-S. Hwang[†], T. W. Nuteson[†], M. B. Steer[†], J. W. Mink[†], J. Harvey[◇], and A. Paoletta[□]

[†] Electronics Research Laboratory, Department of Electrical and Computer Engineering, North Carolina State University, Raleigh, NC 27695-7911

[◇] United States Army Research Office, PO Box 12211, Research Triangle Park, NC 27709

[□] Microwave & Lightwave Components Division, AMSRL-EP-MA, US Army Research Laboratory, NJ 07703

Abstract A slab-based quasi-optical power combining system with convex and concave lenses is investigated. Experimental results imply that a concave-lens system has less scattering loss and higher system gains than a convex-lens system. An amplifier gain of 15 dB and a system gain of 8 dB were achieved.

1. Introduction

Many types of quasi-optical power combining systems have been investigated. A type which is particularly compatible with MMIC technology and planar fabrication is the quasi-optical slab power combiner [1,2]. Developments of this system are presented here.

In this paper, both convex-lens and concave-lens quasi-optical slab waveguide systems, shown in Fig. 1, were investigated. The experimental results included scattering loss of lenses, amplifier gain, and passive and active system gains, and showed that the concave-lens system has lower scattering loss and higher system gains. Input power versus output power was also measured, and showed the output power entered saturation as input power was higher than -15 dBm. All the measured data implies that a concave-lens system is more suitable for MMIC as the problem of having dissimilar materials is mitigated.

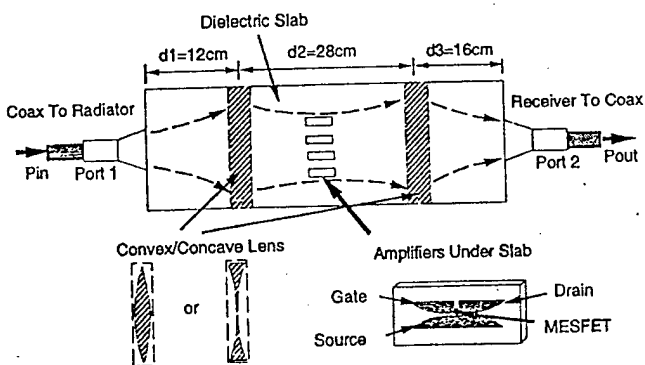

Figure 1: Slab waveguide system with convex/concave lenses.

2. System Description

The complete slab waveguide with convex/concave lenses shown in Fig. 1 consisted of a 4×1 MESFET amplifier array built underneath and between the two lenses. The energy radiated from the input port travels in a quasi-

optical TE Gaussian mode along the slab waveguide where the lenses are used to focus the waves for optimal field distributions on the amplifier elements. To investigate the effect of reducing scattering loss, a metallic top was placed over the system. The amplifier unit was derived from the active notch antenna by Leverich [3] and was described in [2]. The slab waveguide was Rexolite ($\epsilon_r = 2.57$, $\tan\delta = 0.0006$) and was 27.94 cm wide, 62 cm long, and 1.27 cm thick. The convex lenses were Macor ($\epsilon_r = 5.9$, $\tan\delta = 0.0006$), and the focal length is 28.54 cm. The concave lenses were just air, and the focal length is 40.4 cm.

3. Experimental Results and Discussions

The passive system gains were measured on the slab system with no amplifiers present, and is shown in Fig. 2. This measured data shows that the concave-lens system has 4 dB to 6 dB lower loss than the convex-lens system. The E-field patterns across the slab measured at 7.28 GHz is shown in Fig. 3. By integrating the area under the E-field curves in Fig. 3, we estimate the scattering loss is about -3.66 dB for a convex lens, and -1.18 dB for a concave lens. Fig. 2 and 3 reveal that the concave-lens slab system has less scattering loss and will be more appropriate for MMIC.

The amplifier gain, computed from the ratio between $P_{out}(AMP\ ON)$ and $P_{out}(AMP\ OFF)$, is shown in Fig. 4. This gain is about 16 dB and 14 dB respectively for the concave and convex cases. This implies that the amplified power is less scattered in the concave-lens system. The active system gain (defined as P_{in}/P_{out}) is shown in Fig. 5 for the convex and concave cases with and without a metallic top cover. The metallic cover is 12 cm wide and is located 1.6 cm above the system. For the concave case, the active system gain is about 7.7 dB with and without the cover. For the convex case, this gain is about 6 dB and 4 dB with and without the cover, respectively. The active system gain shows that using a metallic top cover can compensate more scattering loss for the convex case than for the concave case. The input and output powers, P_{in} and P_{out} , at 7.12 GHz for both cases without a metal top are shown in Fig. 6. The highest system gains at this frequency were about 2 dB and 4.5 dB for the convex and concave cases, respectively. This figure shows the 1:1 ratio between P_{out} and P_{in} as $P_{in} < -15$ dBm, and shows that P_{out} reached the saturation condition as $P_{in} > -15$ dBm.

4. Conclusion

Quasi-optical power combining using a 4×1 MESFET amplifier array in a slab waveguide with convex and concave lenses is achieved. The concave lens system has less scattering loss, higher amplifier and system gains than the convex lens system, and is more suitable for MMIC. To achieve higher active system gain, the input power should be limited under the saturation condition of the amplifier array.

References

- [1] F. Poegel, S. Irrgang, S. Zeisberg, A. Schuenemann, G. P. Monahan, H. Hwang, M. B. Steer, J. W. Mink, F. K. Schwing, A. Paolletta, and J. Harvey, "Demonstration of an oscillating quasi-optical slab power combiner," *IEEE MTT-S Int. Microwave Symp. Dig.*, pp. 917-920, May 1995.
- [2] H. Hwang, G. P. Monahan, M. B. Steer, J. W. Mink, J. Harvey, A. Paolletta, and F. K. Schwing, "A dielectric slab waveguide with four planar power amplifiers," *IEEE MTT-S Int. Microwave Symp. Dig.*, pp. 921-924, May 1995.
- [3] W. K. Leverich, X.-D. Wu, and K. Chang, "FET active slotline notch antenna for quasi-optical power combining," *IEEE Trans. Microwave Theory Tech.*, vol. MTT-41, pp. 1515-1517, Sept. 1993.

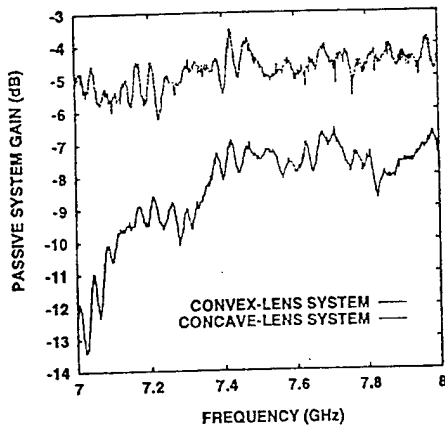

Figure 2: Passive system gains for the convex-lens and concave-lens systems.

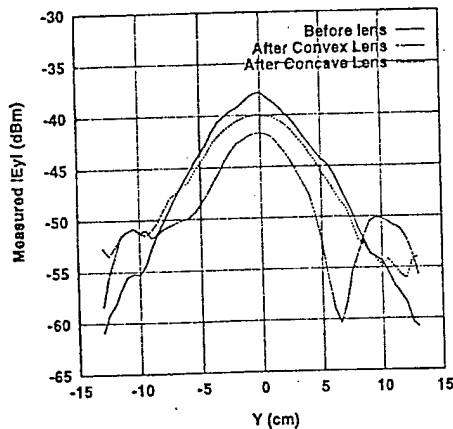

Figure 3: $|E_y|$ distributions across the slab before and after the lenses.

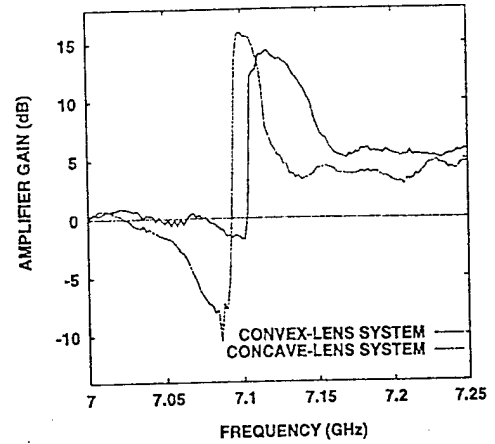

Figure 4: Small signal amplifier gains for the convex-lens and concave-lens systems.

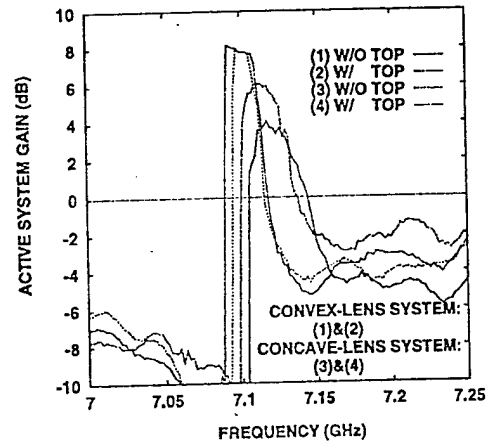

Figure 5: Active system gain for the convex-lens and concave-lens systems.

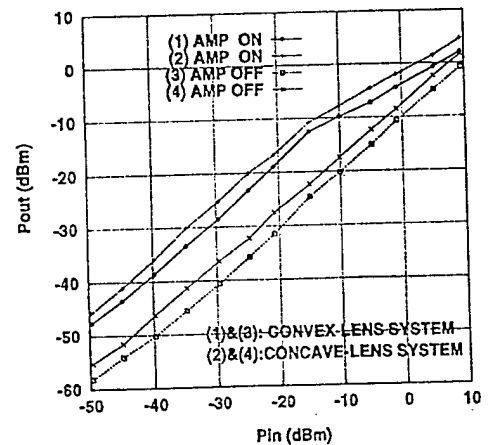

Figure 6: Input and output power of the convex/concave slab system without a metallic top.

Demonstration of an Oscillating Quasi-Optical Slab Power Combiner

F. Poegel¹, S. Irrgang¹, S. Zeisberg¹, A. Schuenemann¹, G. P. Monahan¹,
H. Hwang¹, M. B. Steer¹, J. W. Mink¹, F. K. Schwing¹, A. Paolletta² and J. Harvey³

¹Electronics Research Laboratory, Department of Electrical and Computer Engineering,
North Carolina State University, Raleigh, North Carolina 27695.

²CECOM, AMSEO-RD-C3-ST, Ft. Monmouth, NJ 07703.

³Microwave & Lightwave Components Division, AMSRL-EP-MA, US Army Research Laboratory, NJ 07703

⁴United States Army Research Office, PO Box 12211, Research Triangle Park, NC 27709

Abstract. Power combining in a hybrid dielectric slab beam waveguide resonator using a MESFET oscillator array is reported for the first time. Four MESFET oscillators lock via quasi-optical modes to produce a signal at 7.4 GHz with a 3 dB linewidth of less than 3 kHz.

1. Introduction

The hybrid dielectric slab beam waveguide system [2, 3] combines the wave-guiding principles of a dielectric surface wave and a confined beam corresponding to Gauss-Hermite beam modes. This two dimensional structure has reduced size and is more amenable to photolithographic reproduction than more conventional open quasi-optical power combining structures (see [4]). In this paper the slab resonator characterized in [3] is used to combine the power of multiple MESFET oscillators.

2. Quasi-optical Slab Power Combiner

The slab resonator power combiner is shown in Figure 1. The resonator consists of a curved and a planar reflector. Energy propagates in a quasi-optical mode in a direction perpendicular to the planar reflector which is at the waist of the resonant modes. The curved reflector is circular approximating the parabolic phase-front of the modes. In this way energy radiating from one

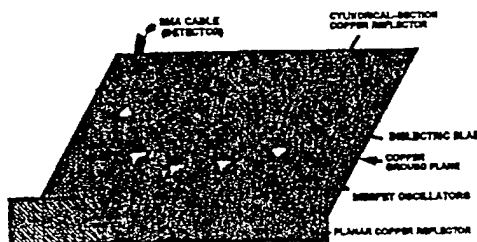

Figure 1: Planar Quasi-optical slab power combining oscillator.

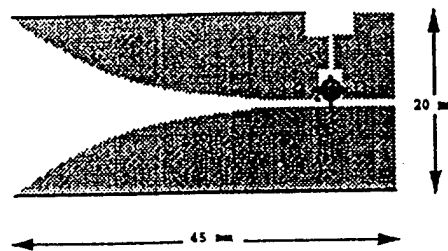

Figure 2: Single oscillator unit constructed on a Rogers RT/Duroid substrate with $\epsilon_r = 2.33$ at 10 GHz.

oscillator is coupled into a quasi-optical mode, which is reflected by the curved reflector and illuminates all of the other oscillators — thus one-to-many coupling is achieved. The distance between the planar reflector and the center of the curved reflector is 30.48 cm, the radius of the curved reflector is 60.96 cm, and the thickness and width of the dielectric slab are 1.27 cm and 38.10 cm respectively. The dielectric is Rexolite ($\epsilon_r = 2.57$, $\tan\delta = 0.0006$ at X-band). The dimensions of the cavity were chosen for X band operation to facilitate the capture of second and third harmonics in the spectrum of the oscillator signal. The cavity and its characteristics are identical to those reported in [3].

An oscillator unit is shown in Figure 2, and uses a Hewlett Packard ATF-10235 MESFET. The essential element of the oscillator is the end-fire Vivaldi antenna taper [5, 6] which provides excellent decoupling of forward and backward traveling waves.

In this paper the design of the oscillating elements was optimized so that oscillation in free space did not occur. This involved optimizing the taper and the drain-gate feedback. Furthermore, this oscillator design was not susceptible to surface-of-slab to ground-plane resonance. This was a common problem with earlier antenna designs since the thickness of the slab is close

to a half wavelength. Cavity signals were sensed by a Vivaldi antenna on the periphery of the cavity where the fields are expected to be small. Locking via direct nearest neighbor coupling is avoided by staggering the individual oscillators.

3. Operation

The oscillator spectrum is shown in Figure 3. Locking is achieved via a TE_{00q} HDSBW (hybrid di-

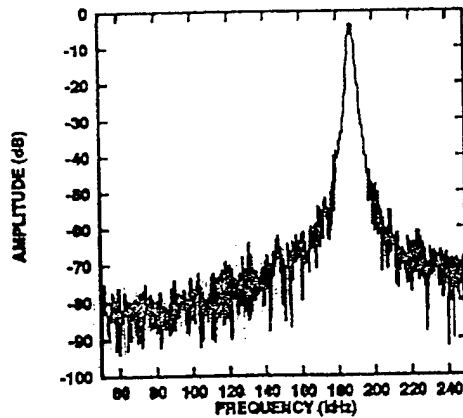

Figure 3: Spectrum with 4 oscillators, frequencies are offset from 7.444 GHz.

electric slab beam waveguide) mode. All possible oscillation modes were found by mounting a single oscillator cell on top of the slab and moving it over the entire surface of the slab and flexing the RT/Duroid substrate. The resultant spectrum with the spectrum analyzer set to maximum hold is shown in Figure 4. Comparing the oscillation frequencies to the unloaded resonator cavity measurements [3], it was determined that the oscillating elements only coupled into the TE hybrid dielectric slab beam waveguide (HDSBW) modes. TE_{mnq} modes have an electric field parallel to the ground plane and transverse to the cavity axis. The m index refers to field variations through the slab and the n index to variations across the slab. The q is often dropped but refers to the number of standing wave patterns along the axis of the resonator. Oscillation via TE_{00q} mode resonances is preferred as these modes have the lowest loss because the energy is mostly inside the dielectric and is localized along the axis of the resonator.

Below 7 GHz the oscillator couples into TE_{0nq} , $n = 1, 2, 3$ modes but above this frequency only TE_{00q} modes are excited as shown in Figure 4. Oscillation frequencies in the range from 7 to 8 GHz are 7.15, 7.44, 7.70 and 7.95 GHz which correspond to TE_{00q} resonances of 7.15, 7.43, 7.72 and 8.00 GHz without the oscillator cell in place [3]. Oscillation above 8 GHz is not observed presumably because of the frequency limitations of the transistor. Furthermore only TE_{00q} modes

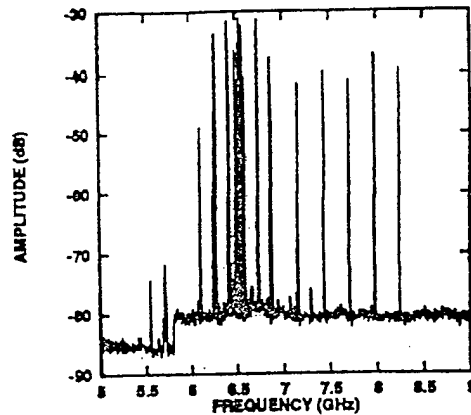

Figure 4: Max hold spectrum with oscillator unit moved over slab. At any one time there is at most only one oscillation frequency.

were excited when the oscillator was near the cavity axis. As such it was a simple matter to select the desired TE_{00q} modes. In this arrangement the oscillators are staggered to avoid nearest neighbor coupling. The desired one-to-many coupling was experimentally verified by selectively suppressing quasi-optical modes by strategically placing pieces of absorbing material at various positions on the slab. Earlier designs were plagued by direct reflections from the curved reflector inducing lock without the establishment of quasi-optical modes. Such oscillations were characterized by broad oscillation line widths.

The procedure for establishing the frequency of oscillation is to establish the dimensions of the cavity (which selects a set of possible TE oscillation modes), apply bias to the on-axis oscillator first (which ensures TE_{00} modes), and tune the length of the drain-gate feedback slit. With this procedure two or three oscillation frequencies are still possible. Which one is selected depends on the distance of the on-axis oscillator from the curved reflector. This has been determined to be due to the establishment of nonquasi-optical interaction between the reflector and the on-axis oscillator. This is undesirable and is an aspect of ongoing engineering efforts. However with appropriate selection of this separation, oscillation at a particular frequency can be accurately and repeatably reproduced when the entire structure is disassembled and reassembled.

4. Results and Discussion

In Figure 5 the oscillation behavior with 1, 2, 3 and then 4 oscillators biased is investigated. The oscillators are arranged on the slab as shown in Figure 1. Note that with just one oscillator (the on-axis one) biased the oscillation is shifted relative to that shown in Figure 4 due to the presence of the other oscillation units on the slab.

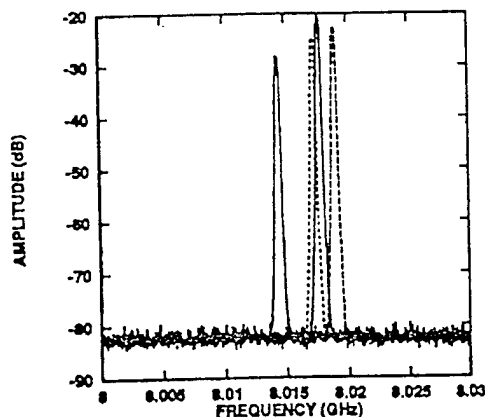

Figure 5: Spectrum with 1, 2, 3 and then 4 oscillator units biased.

Subsequently a second, then third and fourth oscillators were biased. With four oscillator units the linewidth is < 6 kHz at 30 dB down (as determined by a single sweep Hewlett Packard HP8566A spectrum analyzer measurement as shown in Figure 3. Over an extended interval (10 s and longer) the center frequency wanders by up to 7 kHz with negligible change in output power level. At all times the narrow linewidth was maintained. The measured DC-to-RF efficiency was 1%. This is low and is attributed to the low coupling of the sense antenna which is on the edge of the cavity. More realistic on-axis efficiency measurement awaits the development of a fully engineered system with a partially transmitting curved reflector and lenses to propagate and then collect the radiated power.

Injection locking the power combining oscillator with a signal from a Hewlett Packard HP8340B synthesized source 35 dB below the oscillator level reduces the linewidth to < 3 Hz at 30 dB down. Here the resolution bandwidth of the spectrum analyzer was set to the minimum resolution of 1 Hz. Single shot and max hold spectra are shown in Figures 6 and 7. The lock-in bandwidth is 350 kHz and the locking bandwidth is 470 kHz. Increasing the power of the injected signal by 3 dB increases the bandwidth to 590 kHz and 700 kHz respectively. Injection locking by an FM modulated signal at 50 kHz and then 350 kHz is shown in Figures 8 and 9.

5. Conclusion

For the first time a quasi-optical slab power combiner using an oscillator array has been demonstrated. In its present form the HDSBW power combiner is limited to only a few oscillator elements as the presence of the oscillators disturbs the quasi-optical field structure. The next phase of the work will be to move the oscillator elements under the slab so that the field disturbance

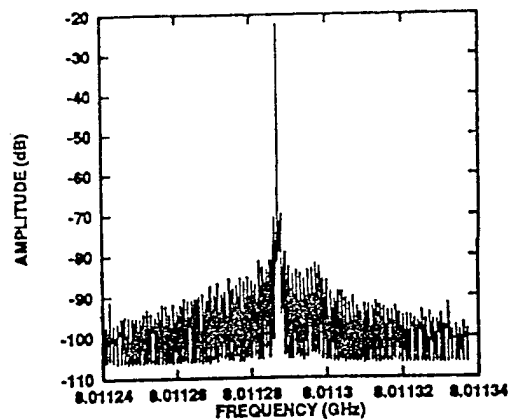

Figure 6: Single shot spectrum with 4 oscillators with injection locking. The resolution bandwidth is 1 kHz.

is minimized.

References

- [1] J. W. Mink, "Quasi-optical power combining of solid-state millimeter-wave sources," *IEEE Trans on Microwave Theory and Techniques*, Vol. 34 Feb. 1986, pp. 273-279.
- [2] J. W. Mink and F. K. Schwing, "A hybrid dielectric slab-beam waveguide for the sub-millimeter wave region," *IEEE Trans. on Microwave Theory and Techniques*, Vol. 41, Oct. 1993, pp. 1720-1729.
- [3] S. Zeisberg, A. Schunemann, G.P. Monahan, P.L. Heron, M.B. Steer, J.W. Mink and F.K. Schwing, "Experimental investigation of a quasi-optical slab resonator," *IEEE Microwave and Guided Wave Letters*, Vol. 3, August 1993, pp. 253-255.
- [4] Special issue on quasi-optical techniques, *IEEE Trans. on Microwave Theory and Techniques*, Vol. 41, Oct. 1993
- [5] H. Meinel, "A 30-GHz FET-oscillator using fin line circuitry," *Proc. 11th European Microwave Conference Digest*, pp. 297-300, 1981.
- [6] W.K. Leverich, X.-D. Wu and K. Chang, "FET active slotline notch antenna for quasi-optical power combining," *IEEE Trans. on Microwave Theory and Techniques*, Vol. 41, pp. 1515-1517, Sept. 1993

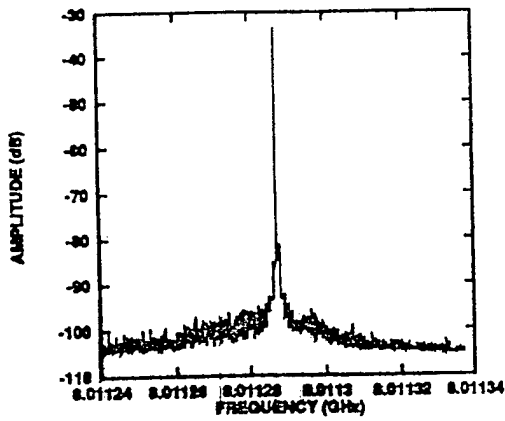

Figure 7: Max hold (10s) spectrum with 4 oscillators and injection locking. The resolution bandwidth is 1 kHz.

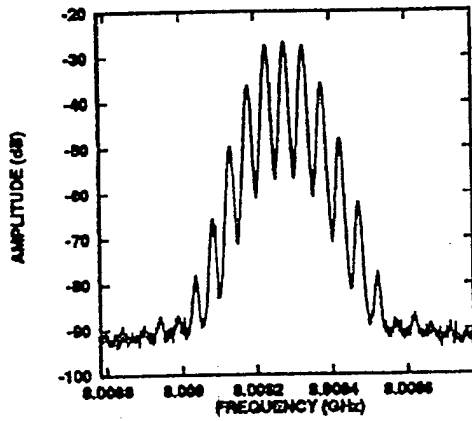

Figure 8: 50 kHz fm modulation.

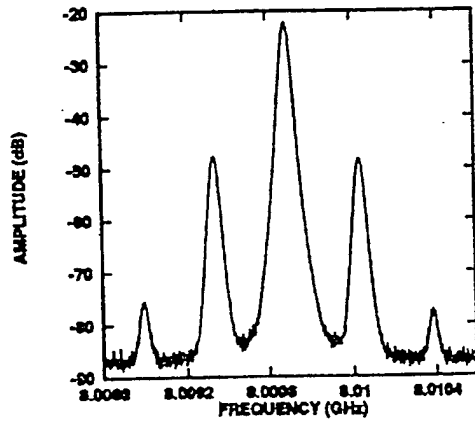

Figure 9: 350 kHz FM modulation.

A Dielectric Slab Waveguide With Four Planar Power Amplifiers

H. Hwang[†], G. P. Monahan[†], M. B. Steer[†], J. W. Mink[†], J. Harvey[◊], A. Paollea[□] and F. K. Schwing^{*}

[†] Electronics Research Laboratory, Department of Electrical and Computer Engineering,
North Carolina State University, Raleigh, NC 27695-7911

[◊] United States Army Research Office, PO Box 12211, Research Triangle Park, NC 27709

[□] Microwave & Lightwave Components Division, AMSRL-EP-MA, US Army Research Laboratory, NJ 07703

^{*} CECOM, Attn. AMSEL-RD-ST-C, Ft. Monmouth, NJ 07703-5203

Abstract. A hybrid dielectric slab beam waveguide with four MESFET amplifiers employing quasi-optical power combining is reported for the first time. Up to 10 dB power gain is obtained at 7.4GHz. Measurements for power gain, amplifier gain, insertion loss and transverse power distribution are presented. The fabrication technique employed is suitable for planar MMIC circuits.

1. Introduction

Quasi-optical power-combining is a promising method to combine the power from multiple solid-state devices in the microwave and millimeter wave region. A number of quasi-optical structures have been reported including wave beam type [1], grid type [2], microstrip weak coupling type, [3], and hybrid dielectric slab beam waveguide type (HDSBW) [4,5] for power combining. In all cases, power from the radiating elements is combined in free space or in a dielectric over a distance of many wavelengths. The HDSBW system has the advantage of being two-dimensional and is thus more amenable to photolithographic reproduction than the conventional open quasi-optical power combining structures. In this paper, a HDSBW system is reported for the first time, with four MESFET power amplifiers located between lenses as shown in Figure 1. Up to 10 dB power gain is obtained at 7.4GHz.

2. Quasi-optical Slab Power Combiner System

The HDSBW system with MESFET amplifiers and two thin convex lenses is shown in Figure 1. The waveguide system is built as a confocal system so that the guided waves are focused and reiterated periodically. The dielectric slab is Rexolite ($\epsilon = 2.57$, $\tan\delta = 0.0006$ at X-band), and its dimensions are 27.94 cm wide, 114.16 cm long, and 1.27 cm thick. The lenses are fabricated from Macor ($\epsilon = 5.9$, $\tan\delta = 0.0025$ at 100 kHz) with radius=30.48 cm, and the focal length,

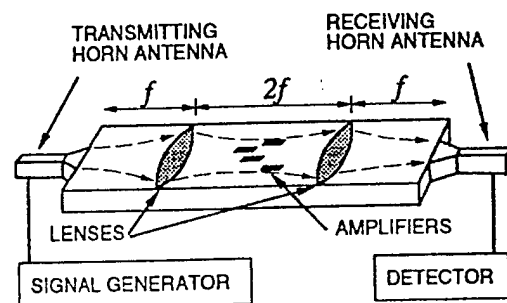

Figure 1: Hybrid dielectric slab beam waveguide (HDSBW) system with MESFET amplifiers.

f , is 28.54 cm. The lenses are inserted into the waveguide with a spacing of 57.08 cm. The aperture width of both horn antennas is 9 cm, designed to be the spot size of the slab beammode near the aperture. Energy propagates in a quasi-optical mode along the waveguide, passes the lenses and is reiterated in the middle area of the waveguide. The beam in that area has the strongest field strength and its width is close to that of the beam width near the radiator. Four MESFET amplifiers are located in this area to amplify the guided energy.

The MESFET amplifier unit is shown in Figure 2 employing one HP ATF-10235 MESFET. The dimension of this amplifier is 7 cm x 1.5 cm. This design is derived from the fin-line oscillator described by Meinel [6] and active slotline notch antenna by Leverich, et. al [7]. The essential structure of the amplifier includes two end-fire Vivaldi antenna tapers which are gate-receiver and drain-radiator. The amplifiers are designed specifically to eliminate surface-of-slab to ground-plane resonance, thus oscillation does not occur when there is no energy radiated from the trans-

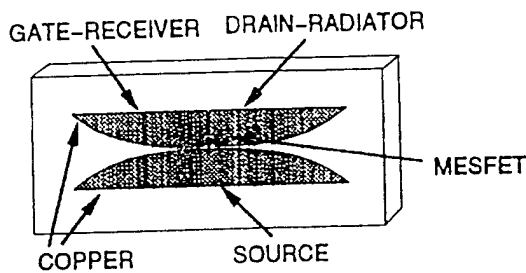

Figure 2: The planar MESFET amplifier.

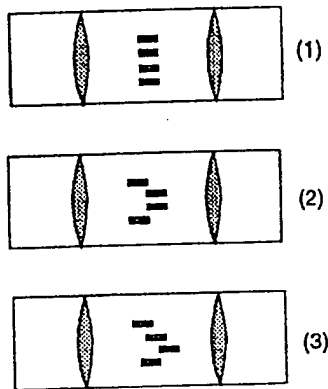

Figure 3: Amplifier configurations.

mitting horn. In the middle area of the waveguide, the refocused guided waves have the narrowest beam width and the strongest field strength. Therefore, amplifiers located in this area amplify the guided energy efficiently. By moving the locations of the amplifiers, different amplifier and power gains are obtained.

3. Measurement and Discussion

Figure 3 shows three different configurations for the MESFET amplifiers on the dielectric slab. In each configuration, the amplifiers are biased with two groups of drain voltage, V_{ds} and gate voltage, V_{gs} , to measure the amplifier gain and the power gain. The bias voltages and the distance between amplifiers were carefully adjusted to avoid mutual-coupling oscillation and to obtain the largest gain in each configuration. To arrange the configurations, an amplifier was first moved around the middle area on the waveguide to get the highest gain. Then, the second amplifier was carefully moved close to the first one, and the bias was adjusted to get the highest gain and avoid oscillations due to strong mutual coupling. Similarly, the third and fourth amplifiers were added to the system.

The amplifier gain and power gain for three dif-

ferent configurations are shown in Figures 4-9. The largest amplifier gains obtained for configurations 1, 2, and 3 were 11 dB, 13.8 dB, and 8 dB, and the largest power gains were 7 dB, 11 dB and 5 dB respectively. This data shows that this 4-amplifier array is effective for the HDSBW in the frequency range from 7 GHz to 8.5 GHz. These figures show that the higher V_{ds} is, the higher the gain is in each location. Amplifier gain is the ratio of the output power with and without bias applied. Power gain is the ratio of the output power with the amplifiers on to that with the amplifiers removed from the surface of the slab. Insertion loss was calculated by subtracting the power gain from the amplifier gain.

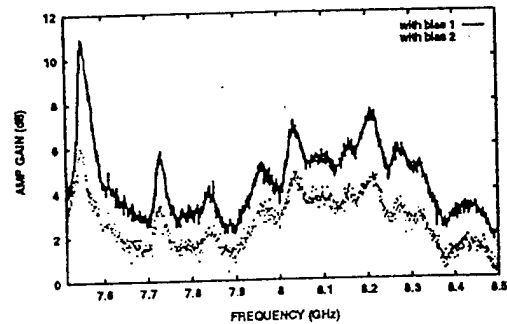

Figure 4: Amplifier gain for configuration 1.

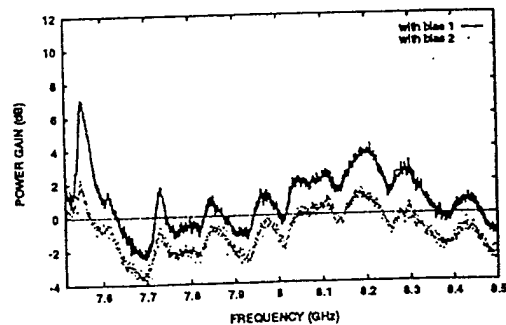

Figure 5: Power gain for configuration 1.

The guided waves are originally a TE slab beam-mode, and when the amplifier patches are placed on the slab surface, they perturb the beammode, causing some losses, which reduce the total received power. The field strength for a fixed position is a function of radiating frequency. Field strength also varies as a function of position for a fixed frequency. Therefore, changing the frequency or the location of amplifiers results in the input energy of the amplifiers being different, and hence the receiving power varies. The in-

sertion loss is shown in Figure 10 for the various cell locations. This loss varies with frequency and location. The causes of insertion loss were further examined by plotting the field profile using the technique shown in Figure 11.

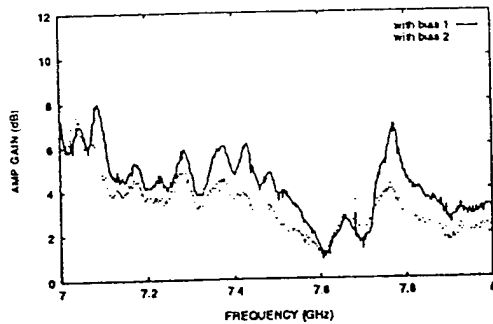

Figure 6: Amplifier gain for configuration 2.

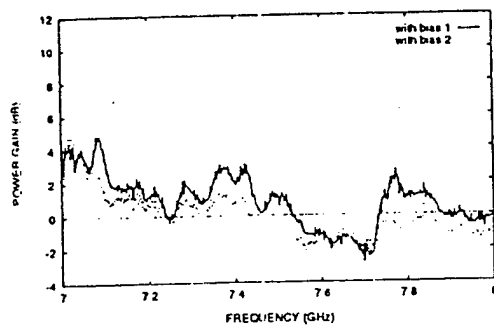

Figure 7: Power gain for configuration 2.

The power distribution across the HDSBW was measured using a small sensor antenna built on RT/Duriod substrate. The amplifiers were put in configuration 3 to supply maximum energy into the slab. Measurements were made at an operating frequency of 7.372 GHz with an amplifier gain of 10.1 dB. The power distribution was measured by moving the sensor antenna along the y -axis from 11.5 cm to -11.5 cm. The power distributions on the slab are plotted in Figure 12 for amplifiers on, amplifiers off, and no amplifiers located on the slab. Comparing the field distributions for amplifiers off and no amplifiers on the slab, the power decreases by a constant value of about 4 or 5 dB in the $-5 \text{ cm} < y < 5 \text{ cm}$ region. This is because all the amplifiers were located here. However, amplification more than compensates this insertion loss. Therefore, the total beammode energy increases. However, the amplifier gain varies greatly in the region $-6.5 \text{ cm} < y <$

11 cm from a maximum of about 32dB at $y = 5 \text{ cm}$ to a minimum at $y = 0 \text{ cm}$ of about 10 dB. Since the amplifiers are not located symmetrically about the z -axis, the power increases more in the $y > 0$ region than in the $y < 0$ region. Unequal amplification and phase shift of the individual amplifiers may also contribute to the non-symmetrical amplification gain.

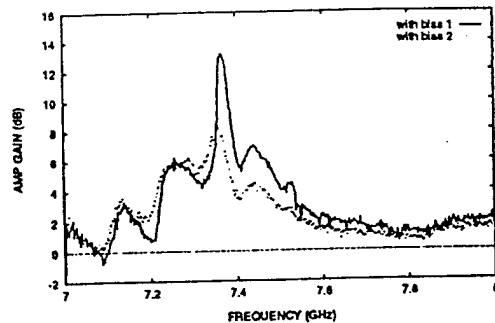

Figure 8: Amplifier gain for configuration 3.

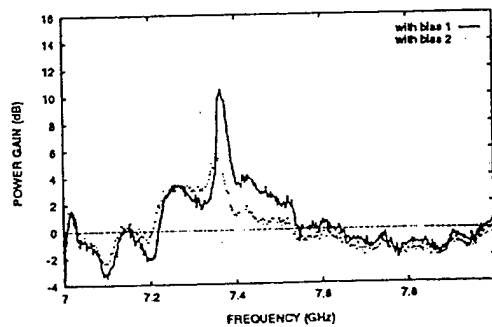

Figure 9: Power gain for configuration 3.

4. Conclusions

For the first time, we have demonstrated a planar amplifier array in a HDSBW using quasi-optical power combining with a maximum amplifier gain of 13 dB at about 7.4 GHz.

Four MESFET amplifiers were located on the slab waveguide near the middle area to amplify the guided energy efficiently. The amplifiers are easily made by photolithographic techniques. By selecting appropriate locations, insertion loss can be reduced significantly. The power difference between the distribu-

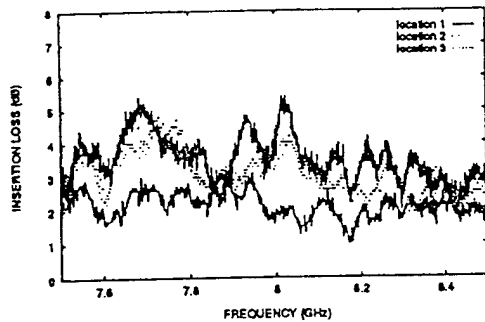

Figure 10: Insertion loss.

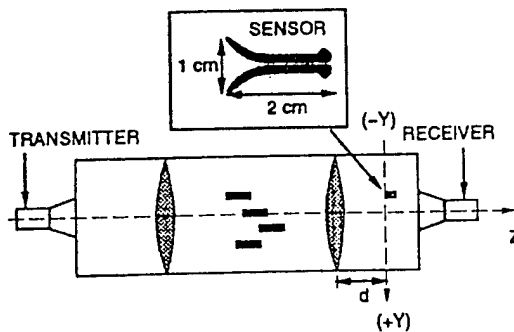

Figure 11: Measurement of power distribution.

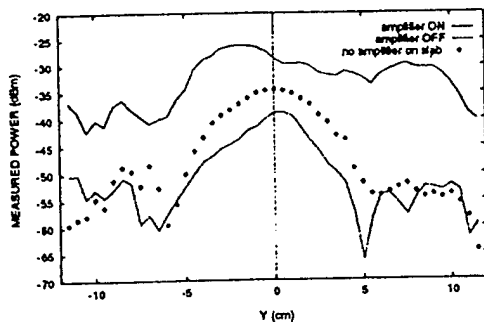

Figure 12: Power distributions across the top of the HDSBW measured at 7.372 GHz at $d = 18.2$ cm as shown in Figure 11.

tions of the slab mode with amplifier on and off increases greatly with a maximum increase of approximately 32dB. The amplifier gain overcomes the insertion loss and results in net gain. This planar amplifier is suitable for use with the HDSBW system and can be applied to planar MMIC circuits.

Acknowledgment

This work was supported in part by the U.S. Army Research Office through grant DAAL03-89-G-0030.

References

- [1] J. W. Mink, "Quasi-optical power combining of solid-state millimeter-wave sources," *IEEE Trans. on Microwave Theory and Techniques*, vol. MTT-34 no. 2, pp. 273-279, February 1986.
- [2] Z. B. Popović, R. M. Weilke, M. Kim and D. B. Rutledge, "A 100-MESFET planar grid oscillator," *IEEE Trans. Microwave Theory Tech.*, vol. MTT-39, no. 2, pp. 193-200, February, 1991.
- [3] R. A. York and R. C. Compton, "Quasi-optical power combining using mutually synchronized oscillator arrays," *IEEE Trans. Microwave Theory Tech.*, vol. MTT-39, no. 6, pp. 1000-1009, June 1991.
- [4] S. Zeisberg, A. Schunemann, G.P. Monahan, P.L. Heron, M.B. Steer, J.W. Mink and F.K. Schwing, "Experimental investigation of a quasi-optical slab resonator," *IEEE Microwave and Guided Wave Letters*, vol. 3, no. 8, pp. 253-255, August 1993.
- [5] J. W. Mink and F. K. Schwing, "A hybrid dielectric slab-beam waveguide for the sub-millimeter wave region," *IEEE Trans. Microwave Theory Tech.*, vol. MTT-41, no. 10, pp.1720-1729, October 1993.
- [6] H. Meinel, "A 30-GHz FET-oscillator using fin line circuitry," *Proc. 11th European Microwave Conference Digest*, pp. 297-300, 1981.
- [7] W. K. Leverich, X.-D. Wu and K. Chang, "FET active slotline notch antenna for quasi-optical power combining," *IEEE Trans. Microwave Theory Tech.*, vol. MTT-41, no. 9, pp.1515-1517, September 1993.

A Dielectric Slab Waveguide With Four Planar Power Amplifiers

H. Hwang[†], G. P. Monahan[†], M. B. Steer[†], J. W. Mink[†], J. Harvey[◊], A. Paollea[□] and F. K. Schwing^{*}

[†] Electronics Research Laboratory, Department of Electrical and Computer Engineering,
North Carolina State University, Raleigh, NC 27695-7911

[◊] United States Army Research Office, PO Box 12211, Research Triangle Park, NC 27709

[□] Microwave & Lightwave Components Division, AMSRL-EP-MA, US Army Research Laboratory, NJ 07703

^{*} CECOM, Attn. AMSEL-RD-ST-C, Ft. Monmouth, NJ 07703-5203

Abstract. A hybrid dielectric slab beam waveguide with four MESFET amplifiers employing quasi-optical power combining is reported for the first time. Up to 10 dB power gain is obtained at 7.4GHz. Measurements for power gain, amplifier gain, insertion loss and transverse power distribution are presented. The fabrication technique employed is suitable for planar MMIC circuits.

1. Introduction

Quasi-optical power-combining is a promising method to combine the power from multiple solid-state devices in the microwave and millimeter wave region. A number of quasi-optical structures have been reported including wave beam type [1], grid type [2], microstrip weak coupling type, [3], and hybrid dielectric slab beam waveguide type (HDSBW) [4,5] for power combining. In all cases, power from the radiating elements is combined in free space or in a dielectric over a distance of many wavelengths. The HDSBW system has the advantage of being two-dimensional and is thus more amenable to photolithographic reproduction than the conventional open quasi-optical power combining structures. In this paper, a HDSBW amplifier is reported for the first time, with four MESFET power amplifiers located between lenses as shown in Figure 1. Up to 10 dB power gain is obtained at 7.4GHz.

2. Quasi-optical Slab Power Combiner System

The HDSBW system with MESFET amplifiers and two thin convex lenses is shown in Figure 1. The waveguide system is built as a confocal system so that the guided waves are focused and reiterated periodically. The dielectric slab is Rexolite ($\epsilon = 2.57$, $\tan\delta = 0.0006$ at X-band), and its dimensions are 27.94 cm wide, 114.16 cm long, and 1.27 cm thick. The lenses are fabricated from Macor ($\epsilon = 5.9$, $\tan\delta = 0.0025$ at 100 kHz) with radius=30.48 cm, and the focal length,

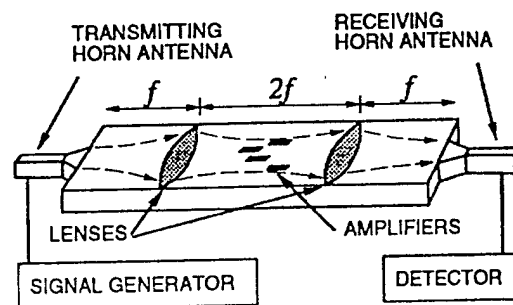

Figure 1: Hybrid dielectric slab beam waveguide (HDSBW) system with MESFET amplifiers.

f , is 28.54 cm. The lenses are inserted into the waveguide with a spacing of 57.08 cm. The aperture width of both horn antennas is 9 cm, designed to be the spot size of the slab beam mode near the aperture. Energy propagates in a quasi-optical mode along the waveguide, passes the lenses and is reiterated in the middle area of the waveguide. The beam in that area has the strongest field strength and its width is close to that of the beam width near the radiator. Four MESFET amplifiers are located in this area to amplify the guided energy.

The MESFET amplifier unit is shown in Figure 2 employing one HP ATF-10235 MESFET. The dimension of this amplifier is 7 cm x 1.5 cm. This design is derived from the fin-line oscillator described by Meinel [6] and active slotline notch antenna by Leverich, et. al [7]. The essential structure of the amplifier includes two end-fire Vivaldi antenna tapers which are gate-receiver and drain-radiator. The amplifiers are designed specifically to eliminate surface-of-slab to ground-plane resonance, thus oscillation does not occur when there is no energy radiated from the trans-

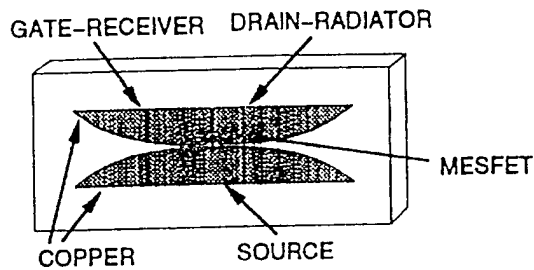

Figure 2: The planar MESFET amplifier.

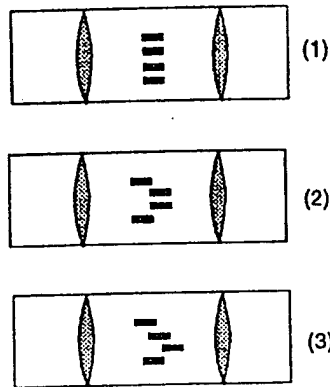

Figure 3: Amplifier configurations.

mitting horn. In the middle area of the waveguide, the refocused guided waves have the narrowest beam width and the strongest field strength. Therefore, amplifiers located in this area amplify the guided energy efficiently. By moving the locations of the amplifiers, different amplifier and power gains are obtained.

3. Measurement and Discussion

Figure 3 shows three different configurations for the MESFET amplifiers on the dielectric slab. In each configuration, the amplifiers are biased with two groups of drain voltage, V_{d1} and gate voltage, V_{g1} , to measure the amplifier gain and the power gain. The bias voltages and the distance between amplifiers were carefully adjusted to avoid mutual-coupling oscillation and to obtain the largest gain in each configuration. To arrange the configurations, an amplifier was first moved around the middle area on the waveguide to get the highest gain. Then, the second amplifier was carefully moved close to the first one, and the bias was adjusted to get the highest gain and avoid oscillations due to strong mutual coupling. Similarly, the third and fourth amplifiers were added to the system.

The amplifier gain and power gain for three dif-

ferent configurations are shown in Figures 4-9. The largest amplifier gains obtained for configurations 1, 2, and 3 were 11 dB, 13.8 dB, and 8 dB, and the largest power gains were 7 dB, 11 dB and 5 dB respectively. This data shows that this 4-amplifier array is effective for the HDSBW in the frequency range from 7 GHz to 8.5 GHz. These figures show that the higher V_{d1} is, the higher the gain is in each location. Amplifier gain is the ratio of the output power with and without bias applied. Power gain is the ratio of the output power with the amplifiers on to that with the amplifiers removed from the surface of the slab. Insertion loss was calculated by subtracting the power gain from the amplifier gain.

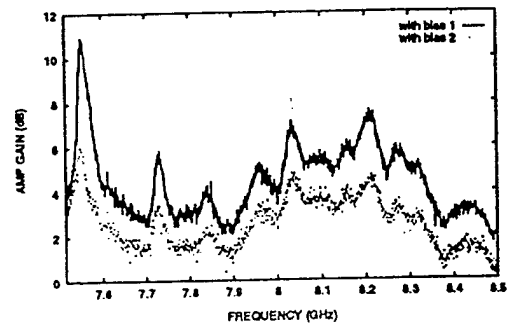

Figure 4: Amplifier gain for configuration 1.

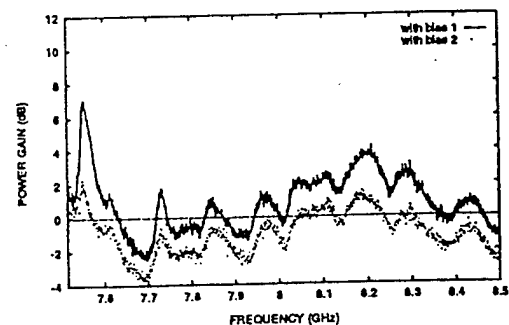

Figure 5: Power gain for configuration 1.

The guided waves are originally a TE slab beam-mode, and when the amplifier patches are placed on the slab surface, they perturb the beammode, causing some losses, which reduce the total received power. The field strength for a fixed position is a function of radiating frequency. Field strength also varies as a function of position for a fixed frequency. Therefore, changing the frequency or the location of amplifiers results in the input energy of the amplifiers being different, and hence the receiving power varies. The in-

sertion loss is shown in Figure 10 for the various cell locations. This loss varies with frequency and location. The causes of insertion loss were further examined by plotting the field profile using the technique shown in Figure 11.

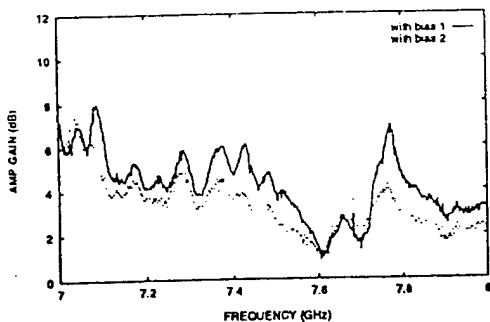

Figure 6: Amplifier gain for configuration 2.

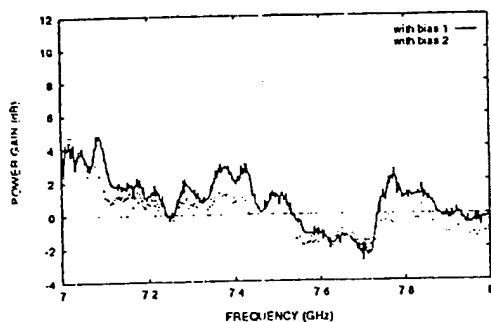

Figure 7: Power gain for configuration 2.

The power distribution across the HDSBW was measured using a small sensor antenna built on RI/Duriod substrate. The amplifiers were put in configuration 3 to supply maximum energy into the slab. Measurements were made at an operating frequency of 7.372 GHz with an amplifier gain of 10.1 dB. The power distribution was measured by moving the sensor antenna along the y -axis from 11.5 cm to -11.5 cm. The power distributions on the slab are plotted in Figure 12 for amplifiers on, amplifiers off, and no amplifiers located on the slab. Comparing the field distributions for amplifiers off and no amplifiers on the slab, the power decreases by a constant value of about 4 or 5 dB in the $-5 \text{ cm} < y < 5 \text{ cm}$ region. This is because all the amplifiers were located here. However, amplification more than compensates this insertion loss. Therefore, the total beammode energy increases. However, the amplifier gain varies greatly in the region $-6.5 \text{ cm} < y <$

11 cm from a maximum of about 32dB at $y = 5 \text{ cm}$ to a minimum at $y = 0 \text{ cm}$ of about 10 dB. Since the amplifiers are not located symmetrically about the z -axis, the power increases more in the $y > 0$ region than in the $y < 0$ region. Unequal amplification and phase shift of the individual amplifiers may also contribute to the non-symmetrical amplification gain.

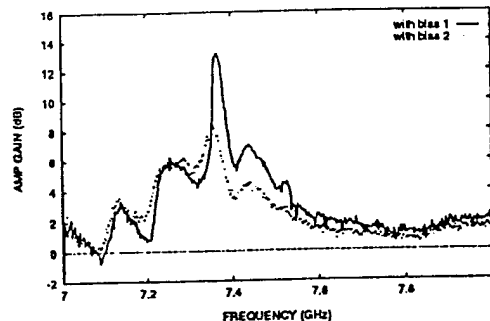

Figure 8: Amplifier gain for configuration 3.

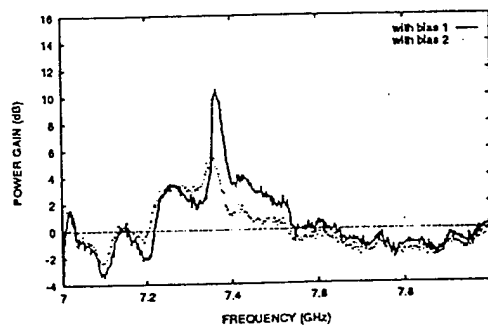

Figure 9: Power gain for configuration 3.

4. Conclusions

For the first time, we have demonstrated a planar amplifier array in a HDSBW using quasi-optical power combining with a maximum amplifier gain of 13 dB at about 7.4 GHz.

Four MESFET amplifiers were located on the slab waveguide near the middle area to amplify the guided energy efficiently. The amplifiers are easily made by photolithographic techniques. By selecting appropriate locations, insertion loss can be reduced significantly. The power difference between the distribu-

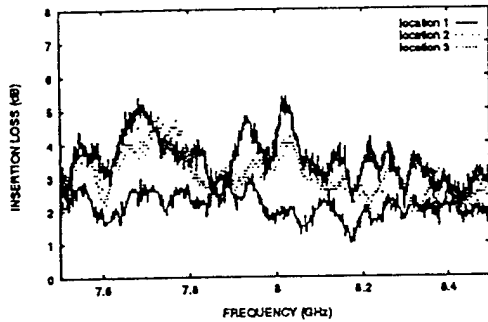

Figure 10: Insertion loss.

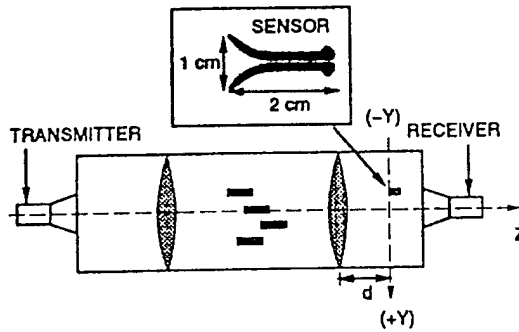

Figure 11: Measurement of power distribution.

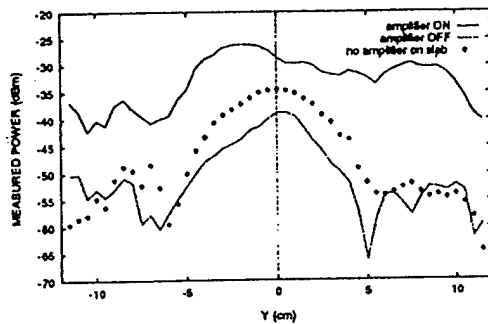

Figure 12: Power distributions across the top of the HDSBW measured at 7.372 GHz at $d = 18.2$ cm as shown in Figure 11.

tions of the slab mode with amplifier on and off increases greatly with a maximum increase of approximately 32dB. The amplifier gain overcomes the insertion loss and results in net gain. This planar amplifier is suitable for use with the HDSBW system and can be applied to planar MMIC circuits.

Acknowledgment

This work was supported in part by the U.S. Army Research Office through grant DAAL03-89-G-0030.

References

- [1] J. W. Mink, "Quasi-optical power combining of solid-state millimeter-wave sources," *IEEE Trans. on Microwave Theory and Techniques*, vol. MTT-34 no. 2, pp. 273-279, February 1986.
- [2] Z. B. Popović, R. M. Weilke, M. Kim and D. B. Rutledge, "A 100-MESFET planar grid oscillator," *IEEE Trans. Microwave Theory Tech.*, vol. MTT-39, no. 2, pp. 193-200, February, 1991.
- [3] R. A. York and R. C. Compton, "Quasi-optical power combining using mutually synchronized oscillator arrays," *IEEE Trans. Microwave Theory Tech.*, vol. MTT-39, no. 6, pp. 1000-1009, June 1991.
- [4] S. Zeisberg, A. Schunemann, G.P. Monahan, P.L. Heron, M.B. Steer, J.W. Mink and F.K. Schwing, "Experimental investigation of a quasi-optical slab resonator," *IEEE Microwave and Guided Wave Letters*, vol. 3, no. 8, pp. 253-255, August 1993.
- [5] J. W. Mink and F. K. Schwing, "A hybrid dielectric slab-beam waveguide for the sub-millimeter wave region," *IEEE Trans. Microwave Theory Tech.*, vol. MTT-41, no. 10, pp.1720-1729, October 1993.
- [6] H. Meinel, "A 30-GHz FET-oscillator using fin line circuitry," *Proc. 11th European Microwave Conference Digest*, pp. 297-300, 1981.
- [7] W. K. Leverich, X.-D. Wu and K. Chang, "FET active slotline notch antenna for quasi-optical power combining," *IEEE Trans. Microwave Theory Tech.*, vol. MTT-41, no. 9, pp.1515-1517, September 1993.