

LOAN DOCUMENT

PHOTOGRAPH THIS SHEET

(0)

INVENTORY

DTIC ACCESSION NUMBER

LEVEL

2 Part's

Bioventing Test Work Plan for Low ...

DOCUMENT IDENTIFICATION

Oct 92

DISTRIBUTION STATEMENT A
Approved for Public Release
Distribution Unlimited

DISTRIBUTION STATEMENT

DATE ACCESSIONED

DATE ACCESSIONED

DATE RETURNED

DATE RETURNED

REGISTERED OR CERTIFIED NUMBER

REGISTERED OR CERTIFIED NUMBER

ACCESSION CODE	
NTIS	ORANI <input type="checkbox"/>
DTIC	TRAC <input type="checkbox"/>
UNANNOUNCED	<input type="checkbox"/>
JUSTIFICATION	<input type="checkbox"/>
BY	
DISTRIBUTION/	
AVAILABILITY CODES	
DISTRIBUTION	AVAILABILITY AND/OR SPECIAL
A-1	

DISTRIBUTION STAMP

QUALITY INSPECTED 4
20010117 007

DATE RECEIVED IN DTIC

PHOTOGRAPH THIS SHEET AND RETURN TO DTIC-FDAC

H
A
N
D
L
E

W
I
T
H

C
A
R
E

PART I

**BIOVENTING TEST WORK PLAN FOR
LOW POINT DRAIN AREA
OFFUTT AFB, NEBRASKA**

PART II

**DRAFT INTERIM TEST RESULTS REPORT FOR
LOW POINT DRAIN AREA
OFFUTT AFB, NEBRASKA**

Prepared For

**Air Force Center for Environmental Excellence
Brooks AFB, Texas**

and

**Headquarters 55th Combat Support Group (SAC)
Offutt AFB, Nebraska**

ES

Engineering-Science, Inc.

October 1992

**1700 BROADWAY, SUITE 900
DENVER, COLORADO 80290**

ES ENGINEERING-SCIENCE

DEFENSE TECHNICAL INFORMATION CENTER REQUEST FOR SCIENTIFIC AND TECHNICAL REPORTS

Title AFCEE Collection

1. Report Availability (Please check one box)

- This report is available. Complete sections 2a - 2f.
- This report is not available. Complete section 3.

2a. Number of Copies Forwarded

1 each

2b. Forwarding Date

July/2000

2c. Distribution Statement (Please check ONE box)

DoD Directive 5230.24, "Distribution Statements on Technical Documents," 18 Mar 87, contains seven distribution statements, as described briefly below. Technical documents MUST be assigned a distribution statement.

- DISTRIBUTION STATEMENT A: Approved for public release. Distribution is unlimited.
- DISTRIBUTION STATEMENT B: Distribution authorized to U.S. Government Agencies only.
- DISTRIBUTION STATEMENT C: Distribution authorized to U.S. Government Agencies and their contractors.
- DISTRIBUTION STATEMENT D: Distribution authorized to U.S. Department of Defense (DoD) and U.S. DoD contractors only.
- DISTRIBUTION STATEMENT E: Distribution authorized to U.S. Department of Defense (DoD) components only.
- DISTRIBUTION STATEMENT F: Further dissemination only as directed by the controlling DoD office indicated below or by higher authority.
- DISTRIBUTION STATEMENT X: Distribution authorized to U.S. Government agencies and private individuals or enterprises eligible to obtain export-controlled technical data in accordance with DoD Directive 5230.25, Withholding of Unclassified Technical Data from Public Disclosure, 6 Nov 84.

2d. Reason For the Above Distribution Statement (in accordance with DoD Directive 5230.24)

2e. Controlling Office

HQ AFCEE

2f. Date of Distribution Statement Determination

15 Nov 2000

3. This report is NOT forwarded for the following reasons. (Please check appropriate box)

- It was previously forwarded to DTIC on (date) and the AD number is
- It will be published at a later date. Enter approximate date if known.
- In accordance with the provisions of DoD Directive 3200.12, the requested document is not supplied because:
.....
.....

Print or Type Name

Laura Peña

Telephone

210-536-1431

Signature

Laura Peña

(For DTIC Use Only)

AQ Number M01-04-0646

**PART I
BIOVENTING TEST WORK PLAN FOR
LOW POINT DRAIN AREA
OFFUTT AFB, NEBRASKA**

**PART II
DRAFT INTERIM TEST RESULTS REPORT FOR
LOW POINT DRAIN AREA
OFFUTT AFB, NEBRASKA**

Prepared for:

Air Force Center for Environmental Excellence
Brooks AFB, Texas

and

Headquarters 55th Combat Support Group (SAC)
Offutt AFB, Nebraska

Prepared by:

Engineering-Science, Inc.
1700 Broadway, Suite 900
Denver, Colorado

October 1992

CONTENTS

Part I - Bioventing Test Work Plan for the Low Point Drain Area

	<u>Page</u>
1.0 Introduction.....	1
2.0 Site Description.....	1
2.1 Site Location and History.....	1
2.2 Site Geology.....	3
2.3 Site Contaminants.....	3
3.0 Site Pilot Test Activities.....	3
3.1 LPD Area Bioventing System Design.....	3
3.2 Handling of Drill Cuttings.....	5
3.3 Soil Sampling.....	10
3.4 Blower System.....	10
4.0 Exceptions to Protocol Procedures.....	14
5.0 Base Support Requirements.....	14
5.1 Test Preparation.....	14
5.2 Initial Pilot Test.....	14
5.3 Extended Pilot Test.....	15
6.0 Project Schedule.....	15
7.0 Points of Contact.....	15
8.0 References.....	16

FIGURES

<u>No.</u>	<u>Title</u>	<u>Page</u>
2.1	Site Location.....	2
2.2	Low Point Drains Location With Respect to Base.....	4
3.1	Proposed Injection Well/Monitoring Point Locations.....	6
3.2	Monitoring Well LPD-MW1 Construction.....	7
3.3	Injection/Venting-Well Construction.....	8
3.4	Typical Monitoring Point Construction Detail.....	9
3.5	Blower System Instrumentation Diagram For Air Injection.....	11
3.6	Blower Assembly.....	12
3.7	Electrical Diagram For Blower System.....	13

CONTENTS

Part II - Interim Test Results Report for Low Point Drain Area

	<u>Page</u>
1.0 Pilot Test Design and Construction	1
1.1 Air Injection Vent Well	4
1.2 Monitoring Points	4
1.3 Blower Unit.....	4
2.0 Pilot Test Soil and Soil Gas Sampling Results	4
2.1 Exceptions to Test Protocol	9
3.0 Test Results	11
3.1 Initial Soil Gas Chemistry.....	11
3.2 Soil Gas Permeability.....	11
3.3 Oxygen Influence	11
3.4 In Situ Respiration Rates	15
3.5 Potential Air Emissions	15
4.0 Recommendations	15
References	22

TABLES

<u>No.</u>	<u>Title</u>	<u>Page</u>
2.1	Soil and Soil Gas Analytical Results.....	10
3.1	Initial Soil Gas Chemistry.....	12
3.2	Maximum Pressure Response and Calculated Permeability Air Permeability Test	13
3.3	Influence of Air Injection at Vent Well on Monitoring Point Oxygen Levels	14

FIGURES

<u>No.</u>	<u>Title</u>	<u>Page</u>
1.1	Vent Well, Monitoring Point and Blower Locations.....	2
1.2	Hydrogeologic Cross Section.....	3
1.3	Injection Vent Well Construction.....	5
1.4	Typical Monitoring Point Construction Detail.....	6
1.5	Monitoring Well LPD-MW1 Construction.....	7
1.6	As-Built Blower System for Air Injection.....	8
3.1	Respiration Test Monitoring Point O1-VW1	16

CONTENTS (Continued)

Page

FIGURES (Continued)

3.2	Respiration Test Monitoring Point LPD-MW1	17
3.3	Respiration Test Monitoring Point O1-MPA-7	18
3.4	Respiration Test Monitoring Point O1-MPB-7.....	19
3.5	Respiration Test Oxygen and Helium Concentrations Monitoring Point O1-MPB-7.....	20

PART I

**BIOVENTING TEST WORK PLAN FOR
THE LOW POINT DRAIN AREA
OFFUTT AFB, NEBRASKA**

Prepared for:

Air Force Center for Environmental Excellence
Brooks AFB, Texas

and

Headquarters 55th Combat Support Group (SAC)
Offutt AFB, Nebraska

by:

Engineering-Science, Inc.
1700 Broadway, Suite 900
Denver, Colorado

September 1992

BIOVENTING TEST WORK PLAN FOR LOW POINT DRAIN AREA OFFUTT AFB, NEBRASKA

1.0 INTRODUCTION

This test work plan presents the scope of a two-phase *in situ* bioventing pilot test for treatment of fuel-contaminated soils at the Low Point Drain (LPD) area at Offutt Air Force Base (AFB), Nebraska. The pilot tests have three primary objectives: 1) to assess the potential for supplying oxygen throughout the contaminated soil depth, 2) to determine the rate at which indigenous microorganisms will degrade fuel when stimulated by oxygen-rich soil gas, and 3) to evaluate the potential for sustaining these rates of biodegradation until fuel contamination is remediated below regulatory standards.

If bioventing proves to be feasible at this site, pilot test data will be used to design a full-scale remediation system and to estimate the time required for site cleanup. An added benefit of the pilot testing at the LPD area is that a significant amount of the fuel contamination should be biodegraded during the 1-year extended pilot test, as the testing will take place within the most contaminated soils that have been detected on the site.

The tests will utilize one air injection well and a 40-standard-cubic-foot-per-minute (scfm) blower to produce a radius of influence of approximately 25 to 30 feet. *In situ* rates of fuel biodegradation will be determined at individual soil vapor monitoring points (MPs).

Additional background information on the development and recent success of the bioventing technology is found in the document entitled *Test Plan and Technical Protocol For A Field Treatability Test For Bioventing* (Hinchee et al., 1992). This protocol document will also serve as the primary reference for pilot test well designs and detailed procedures to be used during the test.

2.0 SITE DESCRIPTION

2.1 Site Location and History

The LPD area is located near Looking Glass Avenue and the Offutt AFB operational apron. The area of concern within the LPD area is located approximately 50 to 100 feet south and east of Building 528. Figure 2.1 shows the location of existing ground water monitoring wells located within and adjacent to

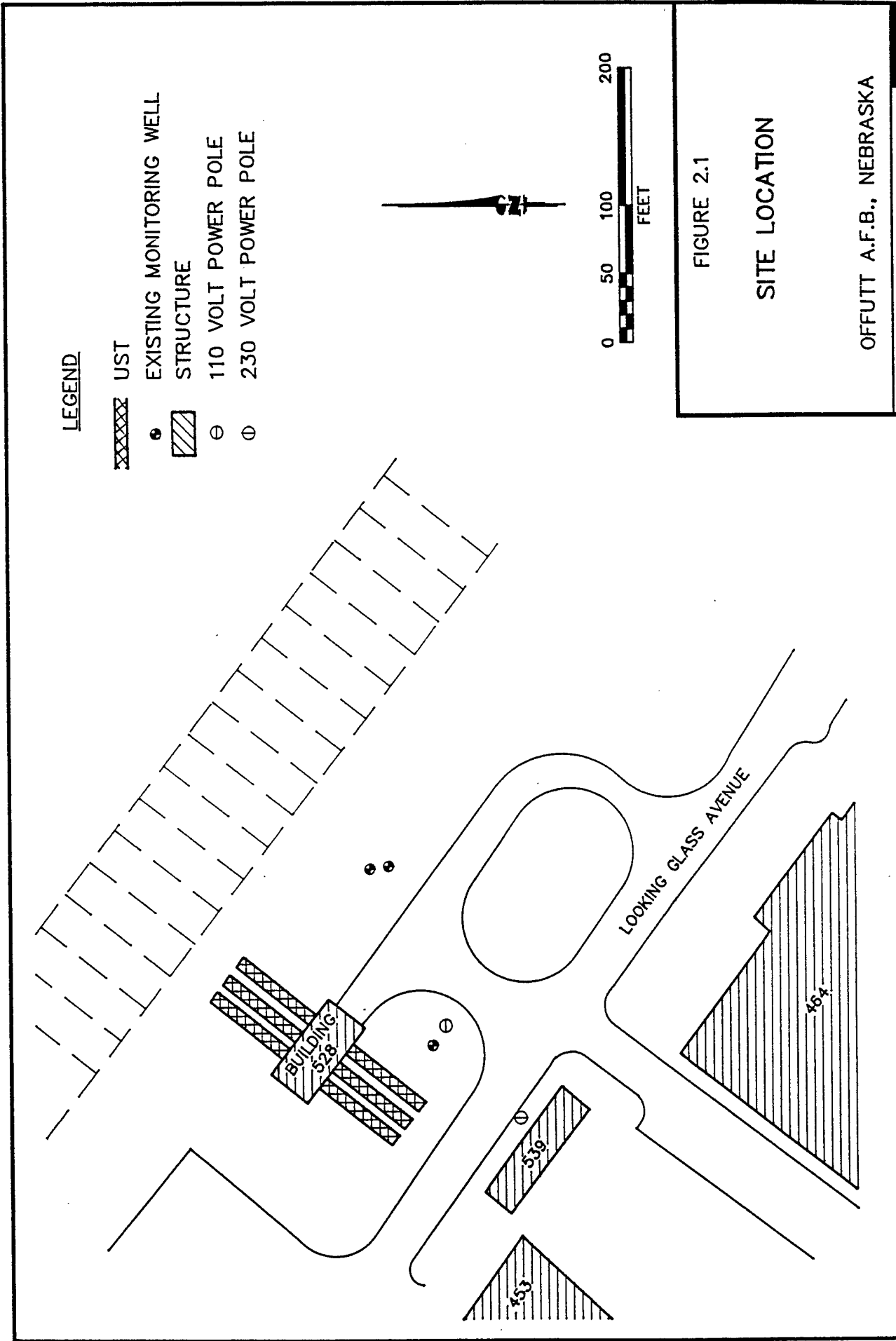

FIGURE 2.1

SITE LOCATION

OFFUTT A.F.B., NEBRASKA

ENGINEERING-SCIENCE, INC.
Denver, Colorado



the area of identified petroleum contamination. The location of the LPDs with respect to the base is shown in Figure 2.2.

Sixteen underground storage tanks (USTs), each with a capacity of 50,000 gallons, are located between Looking Glass Avenue and the operational apron (Figure 2.1). Six of these tanks are located upgradient of the presently identified contamination. These USTs are used to store JP-4 fuel. Additionally, there is an aboveground fuel arm leading to a filling stand where tanker trucks are filled with JP-4 fuel. Contaminated soil resulting from petroleum hydrocarbons presumed to have leaked from these tanks, adjacent pipelines, or from the JP-4 fill stand, is the target for bioventing treatment at this site.

2.2 Site Geology

The stratigraphy at the site consists of glacial deposits overlain by alluvium, and capped by fill varying in thickness from 2 to 10 feet. Ground water is encountered at a depth of approximately 10 feet below ground surface (bgs) and generally flows southward across the base toward Papillion Creek. Ground water flow may be influenced locally by surface water and utility corridors.

2.3 Site Contaminants

The primary contaminants at this site are petroleum hydrocarbons which have been detected in the soils and ground water at depths ranging from 4.0 to 10.5 feet bgs. Total recoverable petroleum hydrocarbon (TRPH) concentrations of 1,250 milligrams per kilogram (mg/kg) have been detected in the soils at a depth of 4.0 to 5.5 feet. Concentrations of the volatile organic compounds (VOCs) benzene, toluene, ethylbenzene, and total xylenes (BTEX) were detected at 7.8 mg/kg in the soils from the boring for well LPD-MW1 (Woodward-Clyde Consultants, 1992).

3.0 SITE PILOT TEST ACTIVITIES

The purpose of this section is to describe the proposed location of the central VW and the MPs at the LPD area. Soil sampling procedures and the blower configuration that will be used to inject air (oxygen) into contaminated soils are also discussed in this section. No well will be completed into the ground water, and no dewatering will take place during the pilot tests. Pilot test activities will be confined to unsaturated soils remediation. Existing monitoring well LPD-MW1 will be used as a soil vapor MP. Additionally, existing uncontaminated monitoring wells which have a portion of their screened interval above the water table may be used to measure the composition of background soil gas.

3.1 LPD Area Bioventing System Design

A 4-inch air injection vent well (VW) will be installed in alignment with two MP locations. Existing well LPD-MW1 will be used as a third MP. The two new soil vapor MPs will be screened at two depths within each location to study the subsurface oxygen distribution pattern during the pilot test. Because the bioventing technology is applied to the unsaturated soils, this test will primarily address soils above the shallow aquifer.

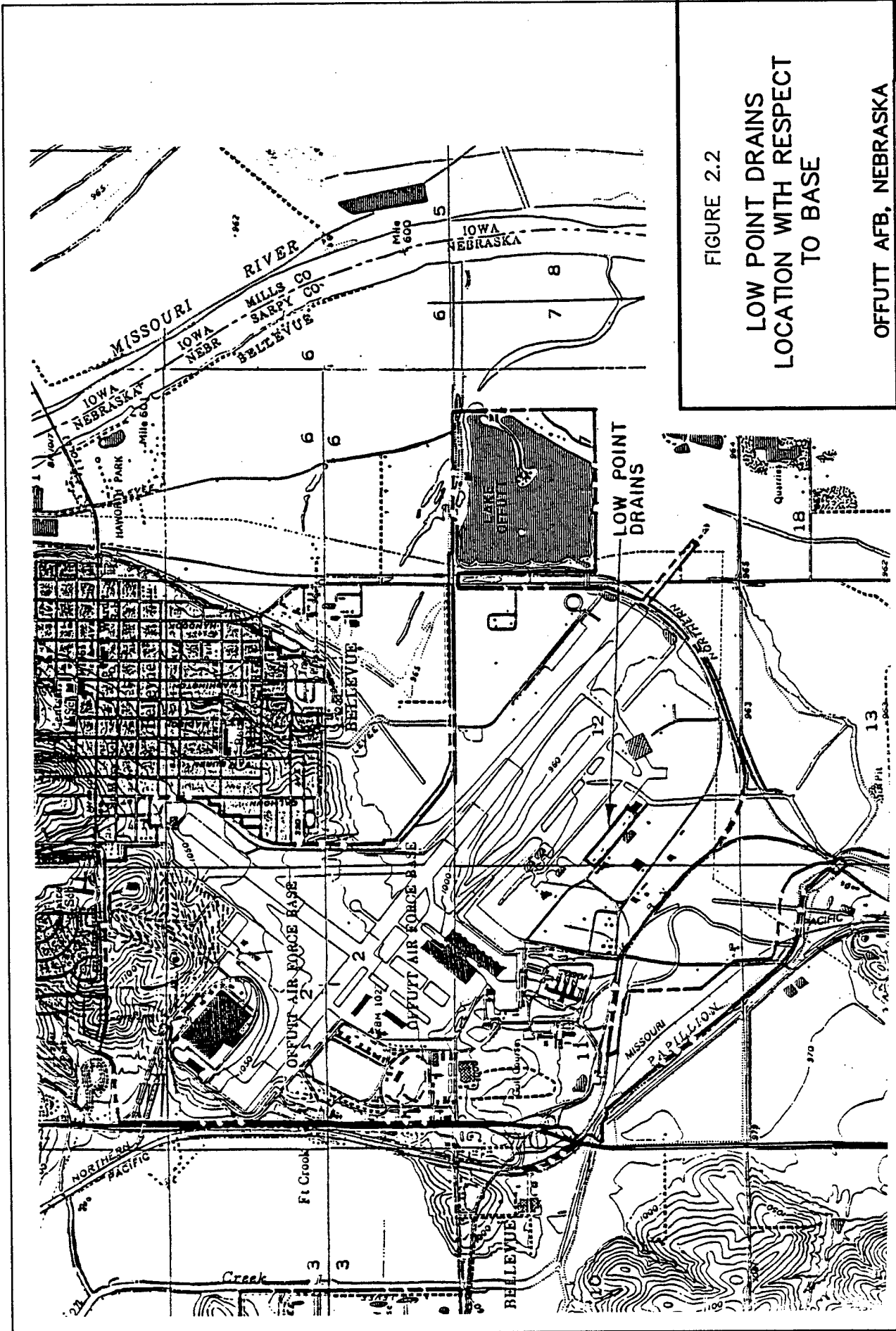

FIGURE 2.2

LOW POINT DRAINS
LOCATION WITH RESPECT
TO BASE

OFFUTT AFB, NEBRASKA

ENGINEERING—SCIENCE, INC.
Denver, Colorado



A general description of criteria for siting a central VW and vapor MPs are included in the protocol document. Figure 3.1 illustrates the proposed locations of the central air injection well and MPs at this site. The final location of these borings may vary slightly from the proposed locations if significant fuel contamination is not observed in the boring for the first MP. Based on site investigation data, the central air injection well should be located in a line located south and downgradient of Building 528 and the associated tank farm. This area is expected to have an average TRPH concentration exceeding 1,000 mg/kg. Existing monitoring well LPD-MW1 will be utilized as one of the three MPs (Figure 3.2). Soils in this area are expected to be oxygen depleted (<2%), and increased biological activity should be stimulated by oxygen-rich soil gas ventilation during pilot test operations.

Due to the relatively shallow depth of contamination at this site, and the potential for low-permeability soils, the radius of venting influence around the central air injection well is expected to be only 25 to 30 feet. Three vapor MPs will be located within a 25-foot radius of the central VW. An effort will be made to use an existing well to measure background levels of oxygen and carbon dioxide and to determine if natural carbon sources are contributing to oxygen uptake during the *in situ* respiration test. Monitoring well FT2-MW3 or another monitoring well installed in clean soils could be used for a background MP if the screened interval extends several feet above the water table. If no suitable existing well is available, a background MP will be constructed. Additional details on the *in situ* respiration test are found in Section 5.7 of the protocol document (Hinchee et al., 1992).

The central air injection well will be constructed of 4-inch inside-diameter (ID) Schedule 40 polyvinyl chloride (PVC), with a 5-foot interval of 0.04-inch slotted screen set at 3.5 to 8.5 feet bgs. Flush-threaded PVC casing and screen, with no organic solvents or glues, will be used. The filter pack will be clean Colorado silica sand with a 6-9 grain size and will be placed in the annular space of the screened interval. A 1.5-foot-thick bentonite seal will be placed directly over the filter pack. A bentonite/cement surface seal to the ground surface will be placed above the bentonite seal. A complete seal is critical to prevent injected air from short-circuiting to the surface during the bioventing test. Figure 3.3 illustrates the proposed central VW construction for this site.

A typical multi-depth vapor MP installation for this site is shown in Figure 3.4. Soil gas oxygen and carbon dioxide concentrations will be monitored at depth intervals of 4 to 5 feet and 7 to 8 feet at each location. Multi-depth monitoring will confirm that the entire soil profile is receiving oxygen, and be used to measure fuel biodegradation rates at these depths. The annular space between these two MPs will be sealed with bentonite to isolate the monitoring intervals. As with the central VW, several inches of bentonite pellets will be used to shield the filter pack from rapid infiltration of bentonite slurry additions. Additional details on air injection VW and MP construction are found in Section 4 of the protocol document.

3.2 Handling of Drill Cuttings

Drill cuttings from all borings will be collected in a Department of Transportation (DOT) approved container, and the containers will be labelled and

FT2-MW3
Page 7
OK

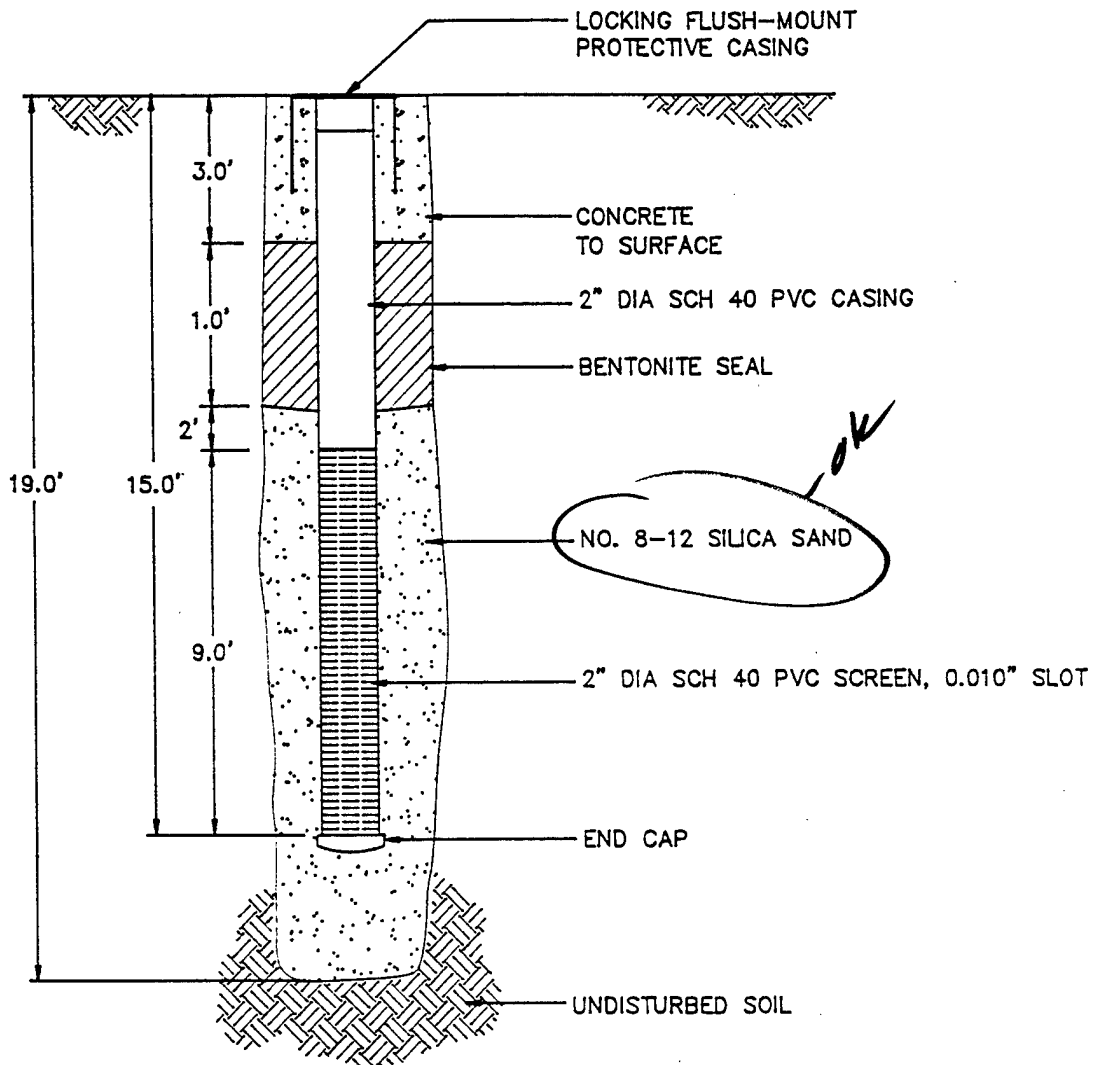

NOT TO SCALE

FIGURE 3.2

MONITORING WELL
LPD-MW1 CONSTRUCTION

OFFUTT A.F.B., NEBRASKA

ENGINEERING-SCIENCE, INC.
Denver, Colorado



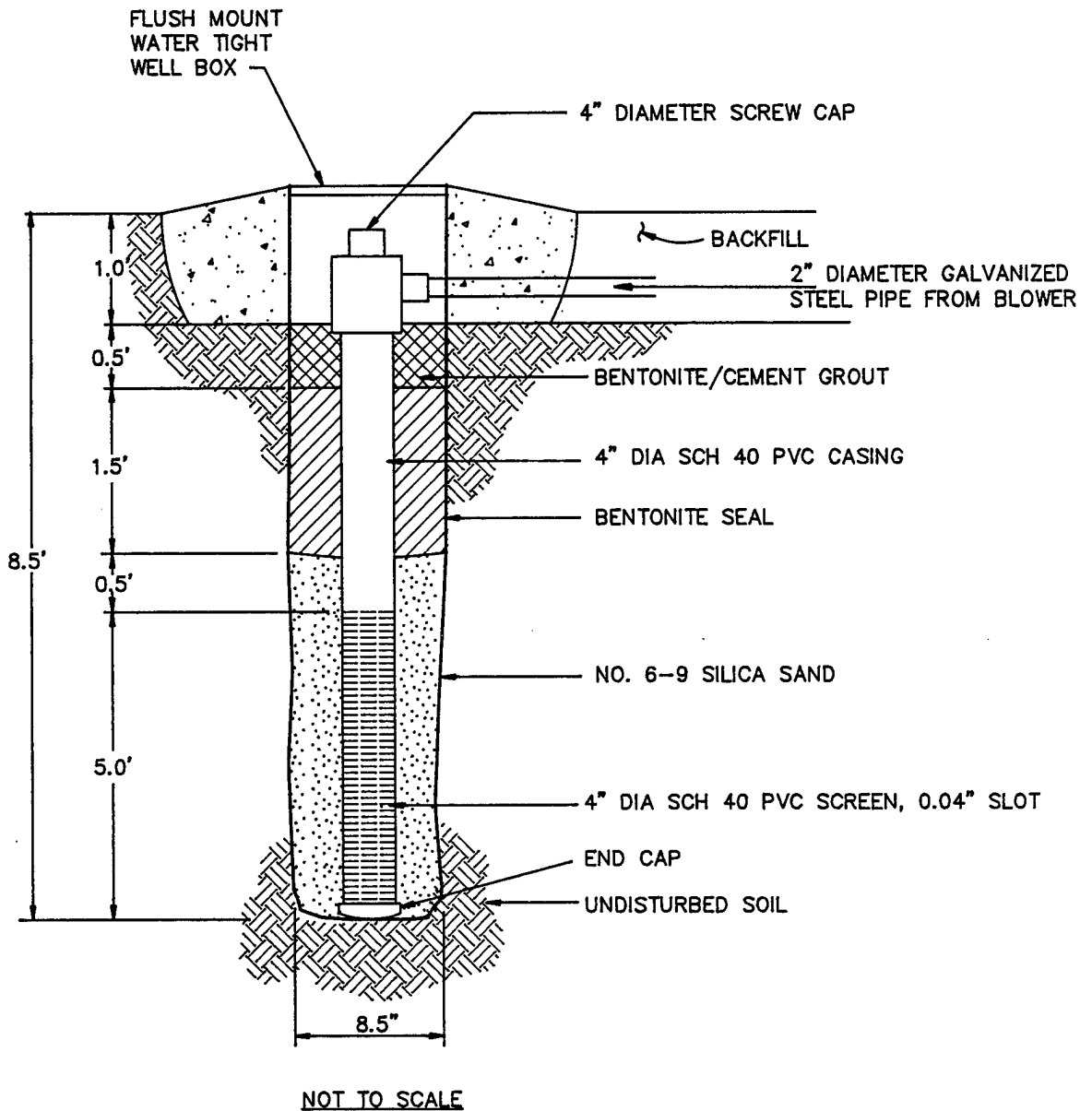

FIGURE 3.3
 INJECTION VENT WELL
 CONSTRUCTION

OFFUTT AFB, NEBRASKA

ENGINEERING-SCIENCE, INC.
 Denver, Colorado



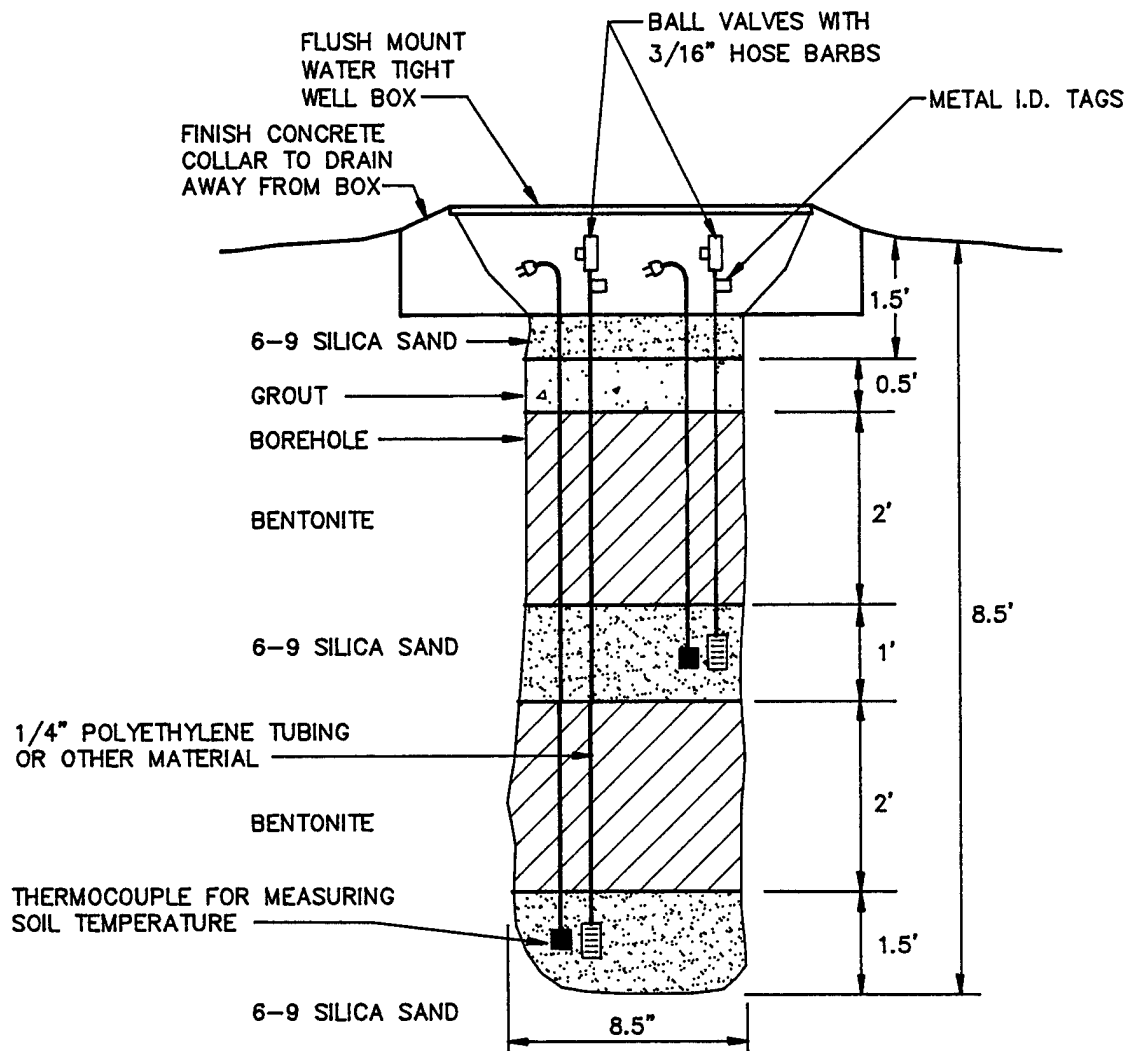

FIGURE 3.4

TYPICAL
MONITORING POINT
CONSTRUCTION DETAIL

OFFUTT A.F.B., NEBRASKA

ENGINEERING-SCIENCE, INC.
Denver, Colorado



placed in the Offutt AFB hazardous material storage area. These drill cuttings will become the responsibility of Offutt AFB and will be analyzed, handled, and disposed of in accordance with the current procedures for ongoing remedial investigations. This project is expected to generate two 55-gallon barrels of cuttings.

3.3 Soil Sampling

Three soil samples will be collected from the pilot test area during the installation of the VW and MPs. Sampling procedures will follow those outlined in the protocol document. One sample will be collected from the most contaminated interval of the central vent well boring. One sample will be collected from the interval of highest apparent contamination in each of the borings for the monitoring points. Soil samples will be analyzed for TRPH, BTEX, soil moisture, pH, particle sizing, alkalinity, total iron and nutrients.

Samples will be collected using a split-spoon sampler containing brass tube liners. A photoionization detector or total hydrocarbon vapor analyzer (see protocol document Section 4.5.2.) will be used to ensure that breathing-zone levels of volatiles do not exceed 1 part per million, volume per volume (ppmv) during drilling, and to screen split-spoon samples for intervals of high fuel contamination. Soil samples collected in the brass tubes will be immediately trimmed, and a Teflon® sheet and a plastic cap will be placed over the ends. Soil samples will be labelled following the nomenclature specified in the protocol document (Section 5.5), wrapped in plastic, and placed in an ice chest for shipment. A chain-of-custody form will be filled out, and the ice chest shipped to the Engineering-Science laboratory in Berkeley, California for analysis. This laboratory has been audited by the U.S. Air Force and meets all quality assurance/quality control and certification requirements for the State of California.

3.4 Blower System

A 3-horsepower, rotary-lobe blower capable of injecting 30 scfm at 12 pounds per square inch (psi) will be used to conduct the initial air permeability test at these sites. This blower provides a wide range of flow rates and should develop sufficient pressure to move air through low-permeability soils. Air injection will be used to provide oxygen to soil bacteria and to minimize emissions of volatiles to the atmosphere. If initial testing indicates that less pressure is required to supply oxygen throughout the test soil volume, a smaller blower will be installed for extended testing. Figure 3.5 is a schematic of a typical air injection system that will be used for pilot testing at this site. Figure 3.6 depicts the blower assembly to be installed.

The maximum power requirement anticipated for this pilot test is a 230-volt, single-phase, 30-amp service. Figure 3.7 shows the electrical diagram for the blower system. Additional details on power supply requirements are described in Section 5.0, Base Support Requirements.

Because of the ongoing fueling operations at the site, this area is considered a Class I Division II Hazardous Area, and it is necessary that the blower motor and starter be explosion proof. Additionally, the cable running to the outlet near the

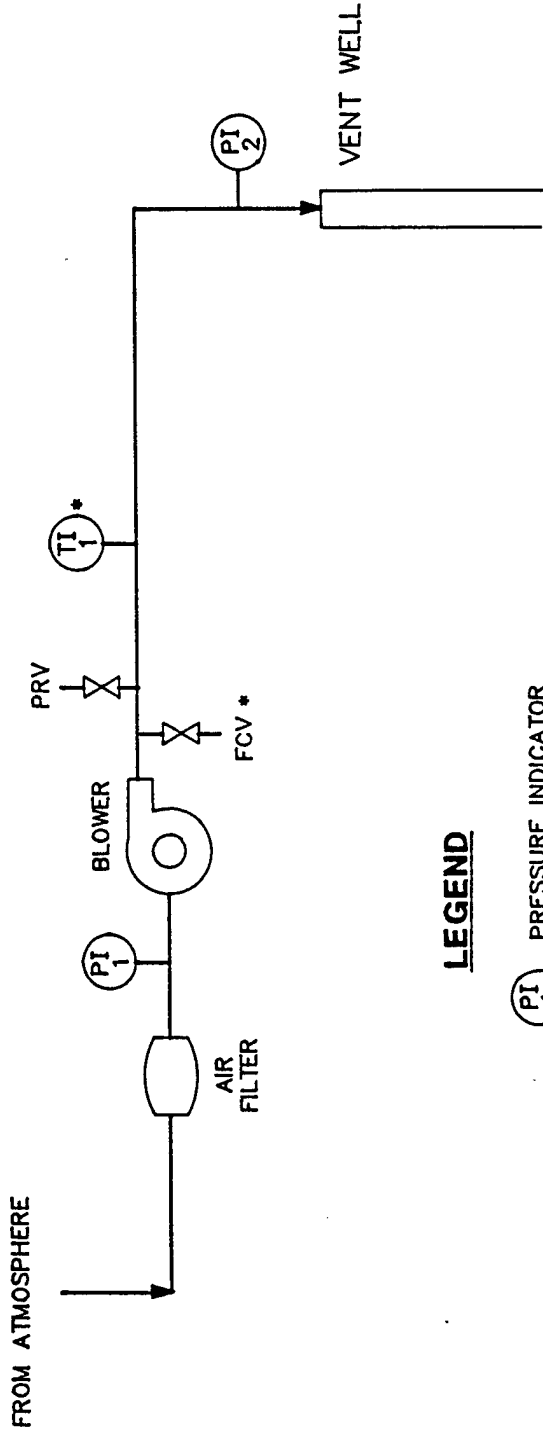

LEGEND

- PI 1 PRESSURE INDICATOR
- TI 1 TEMPERATURE INDICATOR
- FCV FLOW CONTROL VALVE
- PRV PRESSURE RELIEF VALVE
- * OPTIONAL

FIGURE 3.5

**BLOWER SYSTEM
INSTRUMENTATION DIAGRAM
FOR AIR INJECTION**

OFFUTT A.F.B., NEBRASKA

ENGINEERING--SCIENCE, INC.
Denver, Colorado

ES

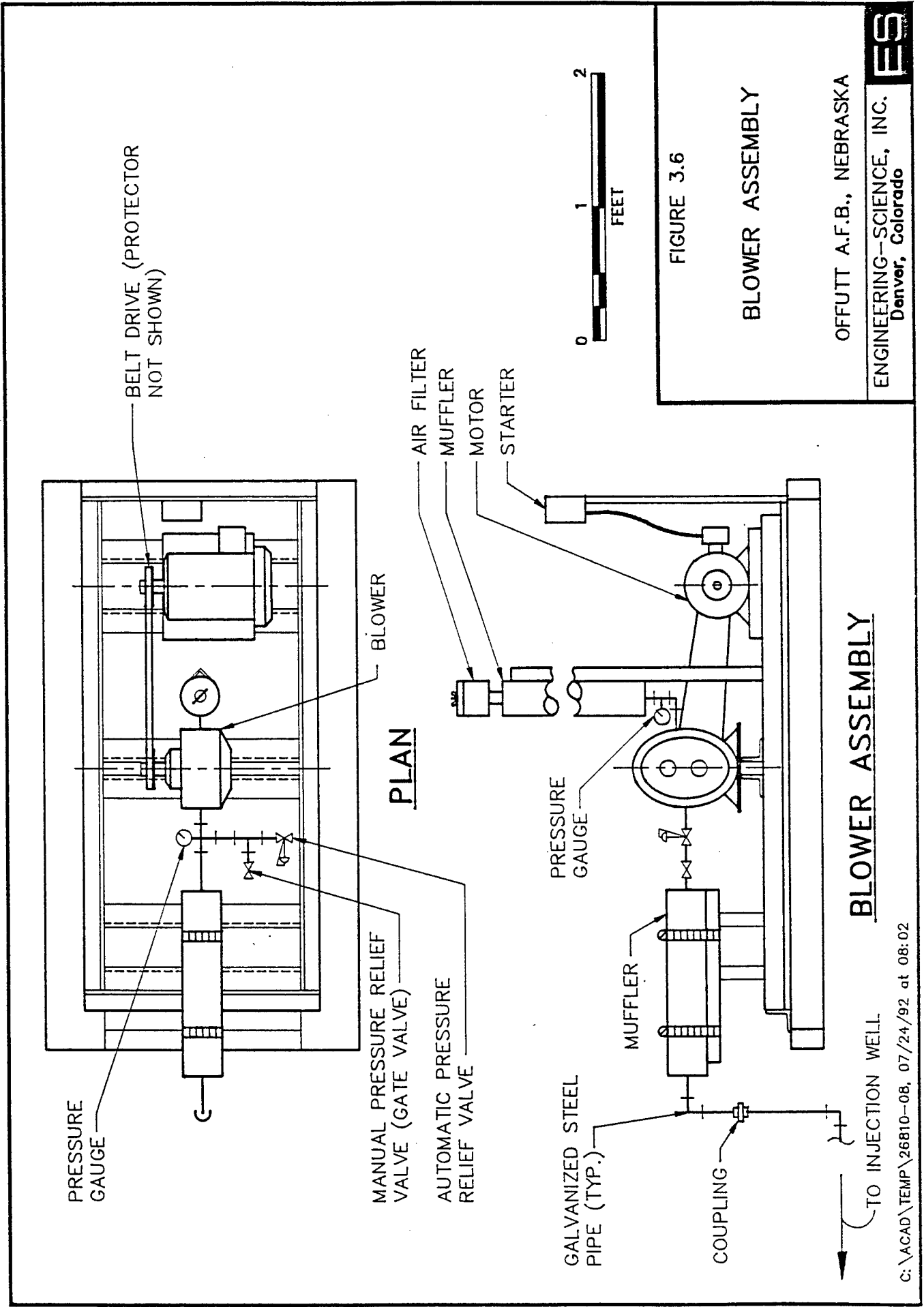

PRESSURE GAUGE

BELT DRIVE (PROTECTOR NOT SHOWN)

MANUAL PRESSURE RELIEF VALVE (GATE VALVE)
 AUTOMATIC PRESSURE RELIEF VALVE

BLOWER

PLAN

AIR FILTER
 MUFFLER
 MOTOR
 STARTER

PRESSURE GAUGE

GALVANIZED STEEL PIPE (TYP.)

COUPLING



FIGURE 3.6

BLOWER ASSEMBLY

BLOWER ASSEMBLY

TO INJECTION WELL

OFFUTT A.F.B., NEBRASKA

ENGINEERING-SCIENCE, INC.
 Denver, Colorado



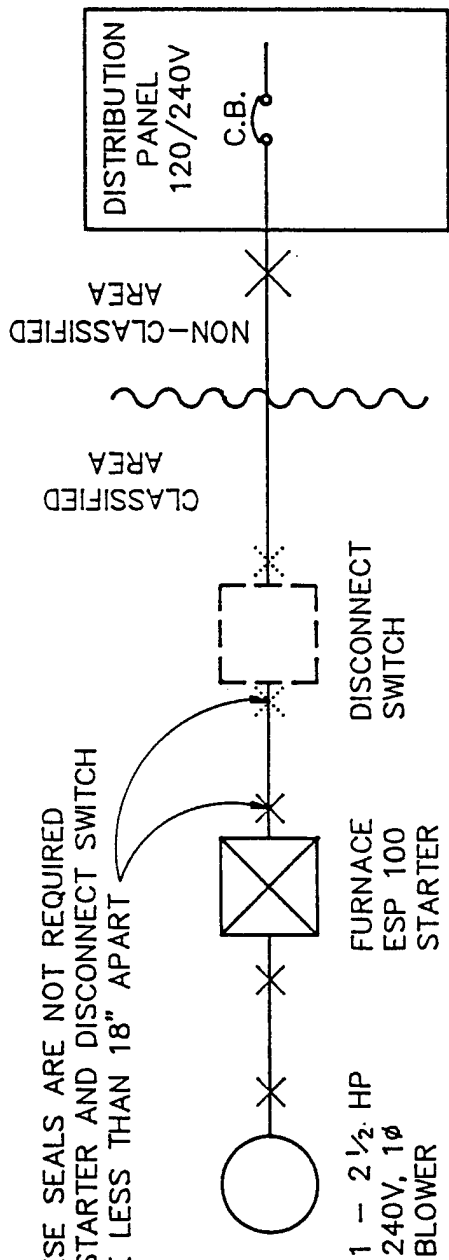

TYPICAL ELECTRICAL ONE LINE DIAGRAM

BLOWER (H.P.)	CONDUIT (R.G.S.)	CONDUCTOR	C.B.
1/2 - 1	3/4"	2 - #12 & 1 #12G	20A/2P
1 1/2	3/4"	2 - #10 & 1 #10G	25A/2P
2	3/4"	2 - #10 & 1 #10G	30A/2P
2 1/2	3/4"	2 - #8 & 1 #10G	40A/2P

NOTES:

1. IF THE MOTOR IS NOT WITHIN A LINE OF SIGHT FROM THE CIRCUIT BREAKER, PROVIDE A 30A/2P NON-FUSED DISCONNECT SWITCH ADJACENT TO THE STARTER (SHOWN AS DASHED ON THIS DRAWING) MOUNT 24" MINIMUM ABOVE FINISHED GRADE.
2. CONDUIT SEALS ARE NOT REQUIRED IF AREA IS NOT CLASSIFIED AS HAZARDOUS.
3. FOLLOW STARTER MANUFACTURER'S WIRING INSTRUCTIONS FOR ADAPTING A 3 PHASE STARTER TO A 2 POLE, SINGLE PHASE APPLICATION.
4. FOLLOW BLOWER MANUFACTURER'S WIRING INSTRUCTIONS TO MATCH BLOWER WIRING WITH VOLTAGE SUPPLIED.

FIGURE 3.7

ELECTRICAL DIAGRAM FOR BLOWER SYSTEM

OFFUTT A.F.B., NEBRASKA
ENGINEERING-SCIENCE, INC.
Denver, Colorado



breaker box will be explosion proof. The breaker box will be located 5 feet above the ground surface so that all nonexplosion-proof connections are above the hazardous area. A qualified electrician will complete these explosion-proof connections.

4.0 EXCEPTIONS TO PROTOCOL PROCEDURES

The procedures that will be used to measure the air permeability of the soil and *in situ* respiration rates are described in Sections 4 and 5 of the attached protocol document. The only foreseen exceptions to the protocol procedures are the possible use of existing wells for use as a vapor MP or as a background MP.

5.0 BASE SUPPORT REQUIREMENTS

5.1 Test Preparation

The following base support is needed prior to the arrival of a driller and the Engineering-Science, Inc. test team:

- Name and phone number of base point of contact provided to the Engineering-Science project manager.
- Confirmation of regulatory approval for the pilot test.
- Assistance in obtaining a digging permit for the LPD site.
- A breaker box mounted to the existing power pole on the site (Figure 2.1) which can supply 230-volt, single-phase, 30-amp service for the initial and extended pilot test. The breaker box should be located 5 feet above the ground and include one 230-volt outlet and two 110-volt outlets to support pilot testing equipment.
- Provide any paperwork required to obtain gate passes and security badges for approximately four Engineering-Science employees and two drillers. Vehicle passes will be needed for two trucks and a drill rig.

5.2 Initial Pilot Test

During the initial 3-week pilot test, the following base support is needed:

- Twelve square feet of desk space and a telephone in a building located as close to the site as practical.
- A decontamination pad where the driller can clean augers between borings.
- Acceptance of responsibility by Offutt AFB for drill cuttings from VW and MP borings, including any drum sampling to determine hazardous waste status.
- The use of a fax machine for transmitting 15 to 20 pages of test results.

5.3 Extended Pilot Test

During the 1-year extended pilot test at the LPD area:

- Check the blower system at the LPD area site once a week to ensure that it is operating and to record the air injection pressure. Engineering-Science will provide a brief training session and an operations and maintenance (O&M) checklist for this procedure.
- Notify Mr. Doug Downey or Ms. Gail Saxton, Engineering-Science, Inc., Denver (303) 831-8100, or Mr. Jim Williams of the Air Force Center for Environmental Excellence (AFCEE), (800) 821-4528, extension 293, if the blower or motor stop working.
- Arrange site access for an Engineering-Science technician to conduct *in situ* respiration tests approximately 6 months and 1 year after the initial pilot test.

6.0 PROJECT SCHEDULE

The following schedule is contingent upon timely approval of this pilot test work plan.

Event	Date
Draft Test Work Plan to AFCEE/Offutt AFB	27 July 1992
Approval To Proceed	31 July
Begin Pilot Test	10 August
Complete Initial Pilot Test	21 August
Interim Results Report	19 October 1992
Respiration Test	February 1993
Final Respiration Test	August 1993

After a period of 1 year, a decision will be made by AFCEE and the base to either remove the system or to expand the system for full-scale remediation at the LPD area site.

7.0 POINTS OF CONTACT

Mr. Phil Cork
SS SG/DEVI Bldg. A
Offutt AFB, NE 68113-5001
(402) 292-3800

Major Ross Miller/Mr. Jim Williams
AFCEE/ESR
Brooks AFB, TX 78235-5000
(800) 821-4528 ext. 282, 293

8.0 REFERENCES

Hinchee, R.E., R.N. Miller, D.C. Downey. 1992. Test Plan and Technical Protocol for a Field Treatability Test for Bioventing. Prepared for USAF Center for Environmental Excellence. May.

Woodward-Clyde Consultants 1992. Step 6 - Initial Site Assessment Low Point Drains. UG No. D11092-RF-0900. Offutt Air Force Base, Nebraska. Omaha, Nebraska.

SECTION 2

PART II
DRAFT INTERIM TEST RESULTS REPORT FOR
LOW POINT DRAIN AREA
OFFUTT AFB, NEBRASKA

Prepared for:

Air Force Center for Environmental Excellence
Brooks AFB, Texas

and

Headquarters 55th Combat Support Group (SAC)
OFFUTT AFB, NEBRASKA

October 1992

by:

Engineering-Science, Inc.
1700 Broadway, Suite 900
Denver, Colorado

PART II
DRAFT
INTERIM TEST RESULTS REPORT FOR
LOW POINT DRAIN AREA
OFFUTT AFB, NEBRASKA

An initial bioventing pilot test was completed at Building 528, Low Point Drain (LPD) area at Offutt Air Force Base (AFB), Nebraska, during the period of 10 through 21 August 1992. The purpose of this Part II report is to describe the results of the initial pilot test at the site and to make specific recommendations for extended testing to determine the long-term impact of bioventing on site contaminants. Descriptions of the history, geology, and contamination at LPD are contained in Part I, the Bioventing Test Work Plan (ES, 1992).

1.0 PILOT TEST DESIGN AND CONSTRUCTION

The bioventing program at Offutt AFB consists of two pilot tests. The initial pilot test is the short term test, performed in August 1992, to determine initial respiration rates, air permeability, and radius of oxygen influence. This interim results report summarizes the findings of the initial pilot test. The long term pilot test is conducted by the installation of a blower at the site and returning to the site at six months and one year after start up of the blower to perform respiration tests and collect samples.

Contamination at the location of the bioventing pilot test within the LPD area consists of petroleum hydrocarbons. Hydrocarbons have been detected in the soil and ground water at depth ranging from 4.0 to 10.5 feet below ground surface.

Installation of an air injection vent well (VW) and vapor monitoring points (MPs) near Building 528 took place on 11 August 1992. Drilling, well installation, and soil sampling were directed by Mr. Jim Walters, the Engineering-Science, Inc. (ES) site manager. The following sections describe the final design and installation of the bioventing system at this site.

One VW and two MPs were installed at the site. A blower unit was also installed. Figures 1.1 and 1.2, respectively, depict the locations of and hydrogeologic cross sections for the VW and MPs completed at the site. Existing well FT2-MW3 was used as a background well at this site (Figure 1.1).

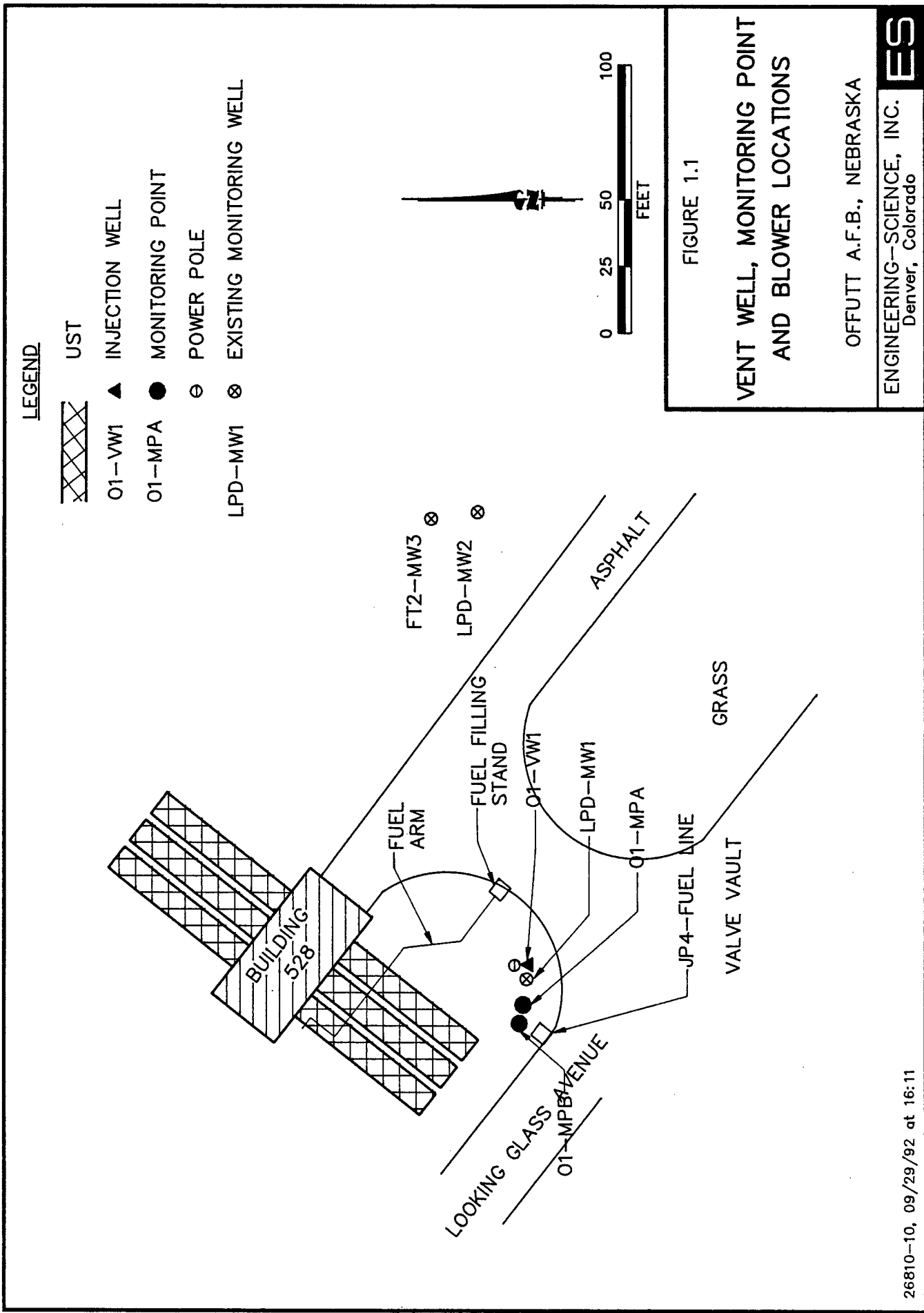

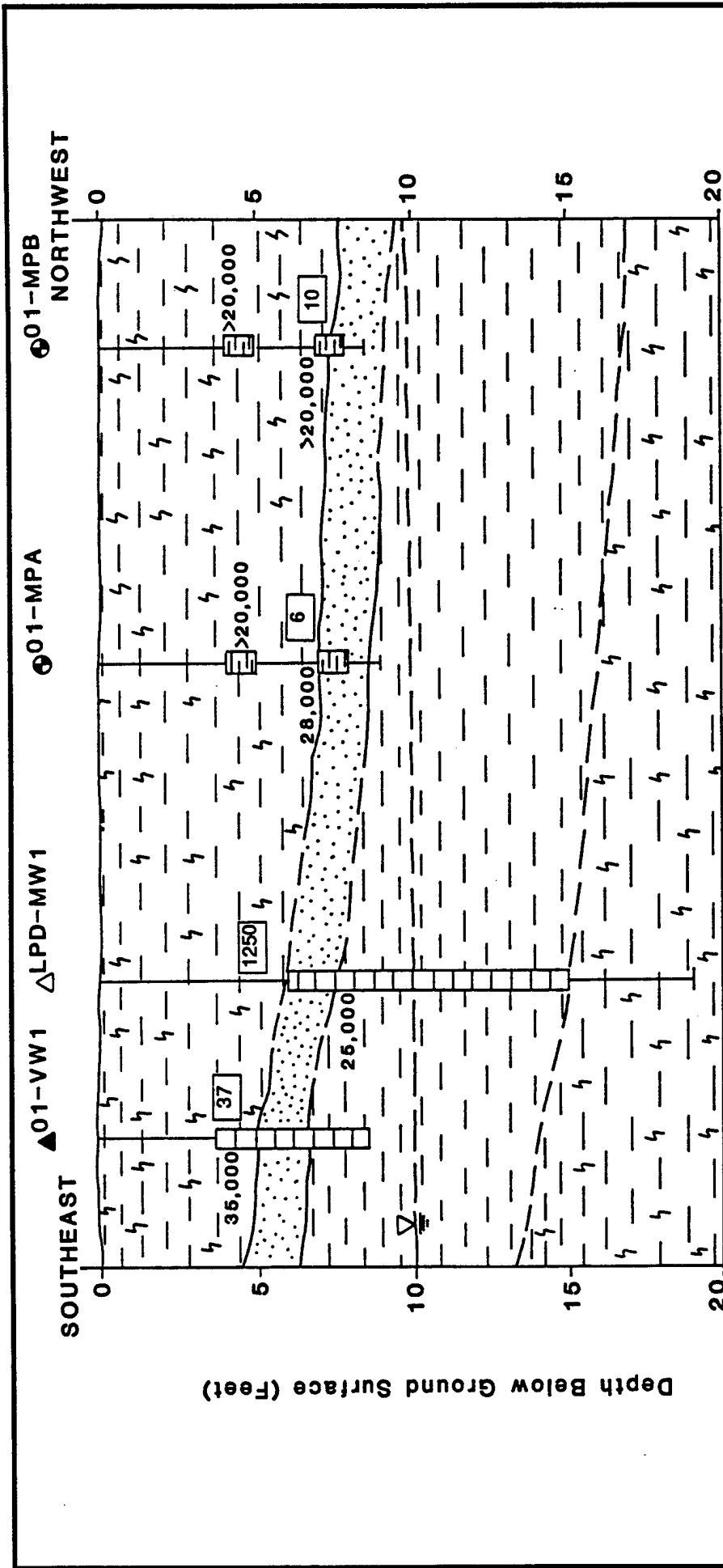

FIGURE 1.2

HYDROGEOLOGIC CROSS SECTION

OFFUTT ABF, NEBRASKA

ENGINEERING-SCIENCE, INC.
Denver, Colorado

ES

LITHOLOGIC DESCRIPTION

LEGEND

- 01-MPA ● MONITORING POINT
- LPD-MW1 △ EXISTING MONITORING WELL
- 01-VW1 ▲ INJECTION WELL
- 35,000 TOTAL VOLATILE HYDROCARBONS (ppmv)
- 37 SOIL TOTAL PETROLEUM HYDROCARBONS (mg/kg)
- ▽— GROUND WATER ELEVATION
- DASHED WHERE INFERRED
- ☐ MONITORING POINT SCREENED INTERVAL
- ☐ SCREENED WELL INTERVAL
- ☐ CLAY
- ☐ SILTY CLAY
- ☐ SAND

1.1 Air Injection Vent Well

The air injection well (O1-VW1) was installed following procedures described in the Air Force Center for Environmental Excellence (AFCEE) protocol document. Figure 1.3 shows construction details for O1-VW1. The VW was constructed using 4-inch-diameter, Schedule 40 polyvinyl chloride (PVC) casing, with 5.0 feet of PVC screen installed from 3.5 to 8.5 feet below ground surface (bgs). The annular space between the well casing and borehole was filled with 6-9 silica sand from the bottom of the borehole to approximately 0.5 foot above the top of the well screen. A 1.5-foot thick bentonite seal composed of bentonite granules was placed above the sand. A bentonite/cement grout was placed above the seal to within 1.0 foot of the ground surface. The top of the well was completed with a 4-inch-diameter cap and 8-inch flush-mounted box.

1.2 Monitoring Points

The MP screens were installed at 4.0- to 5.0- and 7.0- to 8.0- foot depths. The two MPs at this site were constructed as shown in Figure 1.4. Each was constructed using a 6-inch section of 1-inch PVC well screen and a 0.25-inch PVC riser pipe extending to the ground surface. At the top of each riser, a ball valve and 3/16-inch hose barb were installed. The top of each MP was completed with a flush-mounted, metal well protector set in a concrete base. The MP installed at a distance of 15.5 feet west of the VW was labeled O1-MPA, and the MP 25.5 feet west of the VW was labeled O1-MPB (Figure 1.1). Thermocouples were installed at the 4.5- and 8-foot depths at O1-MPB to measure soil temperature variations.

The existing ground water monitoring well, LPD-MW1, also was utilized as an MP. LPD-MW1 is 5.5 feet west of the VW, is 2 inches in diameter, and is screened from 6 to 15 feet bgs (Figure 1.1). Figure 1.5 details the construction of LPD-MW1.

1.3 Blower Unit

A 3-horsepower Roots® positive-displacement blower unit was used for the initial pilot test and was installed for the extended pilot test. The fixed unit is energized by a 230-volt, single-phase, 30-amp line power from a nearby circuit breaker. The extended-testing blower presently in place will be injecting 36 standard cubic feet per minute (scfm) at 28 inches of water pressure. The configuration, instrumentation, and specifications for the blower system are shown on Figure 1.6. Due to lower than expected steady-state injection pressure, it has been determined that a regenerative blower will enhance the radius of oxygen influence. This new blower will be installed in October 1992.

ES has provided an operations and maintenance manual to base personnel including a briefing document, maintenance checklist, and manufacture's blower manual. A copy of the checklist is provided in Appendix A.

2.0 PILOT TEST SOIL AND SOIL GAS SAMPLING RESULTS

The generalized soil profile at this site consists of a medium-brown to green silty-clay from the ground surface to approximately 5 to 7 feet bgs. This is underlain by a grey, fine- to medium-grained sand unit, ranging from 1 to 2 feet thick. Geologic

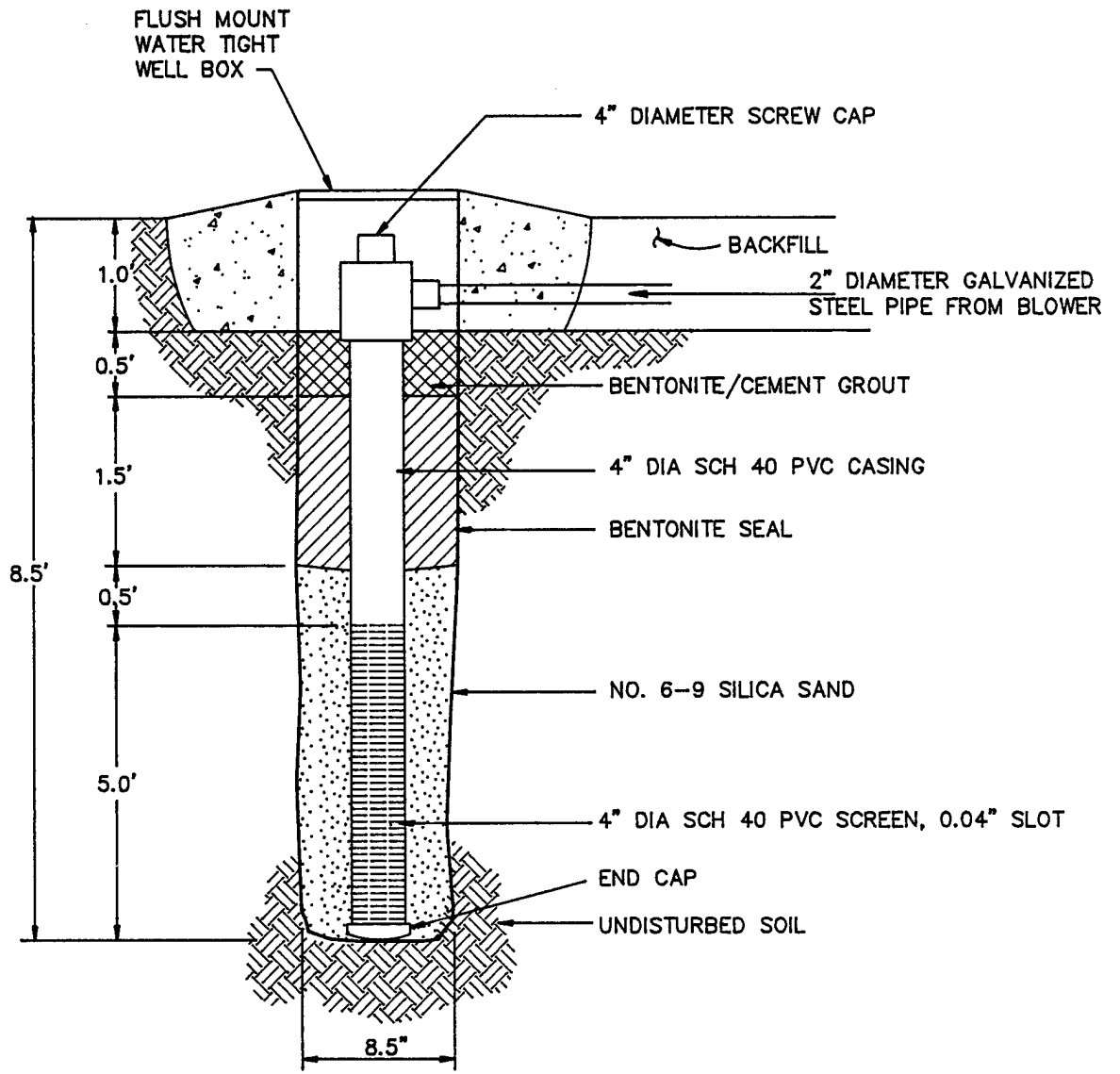

NOT TO SCALE

FIGURE 1.3
 INJECTION VENT WELL
 CONSTRUCTION

OFFUTT AFB, NEBRASKA

ENGINEERING-SCIENCE, INC.
 Denver, Colorado



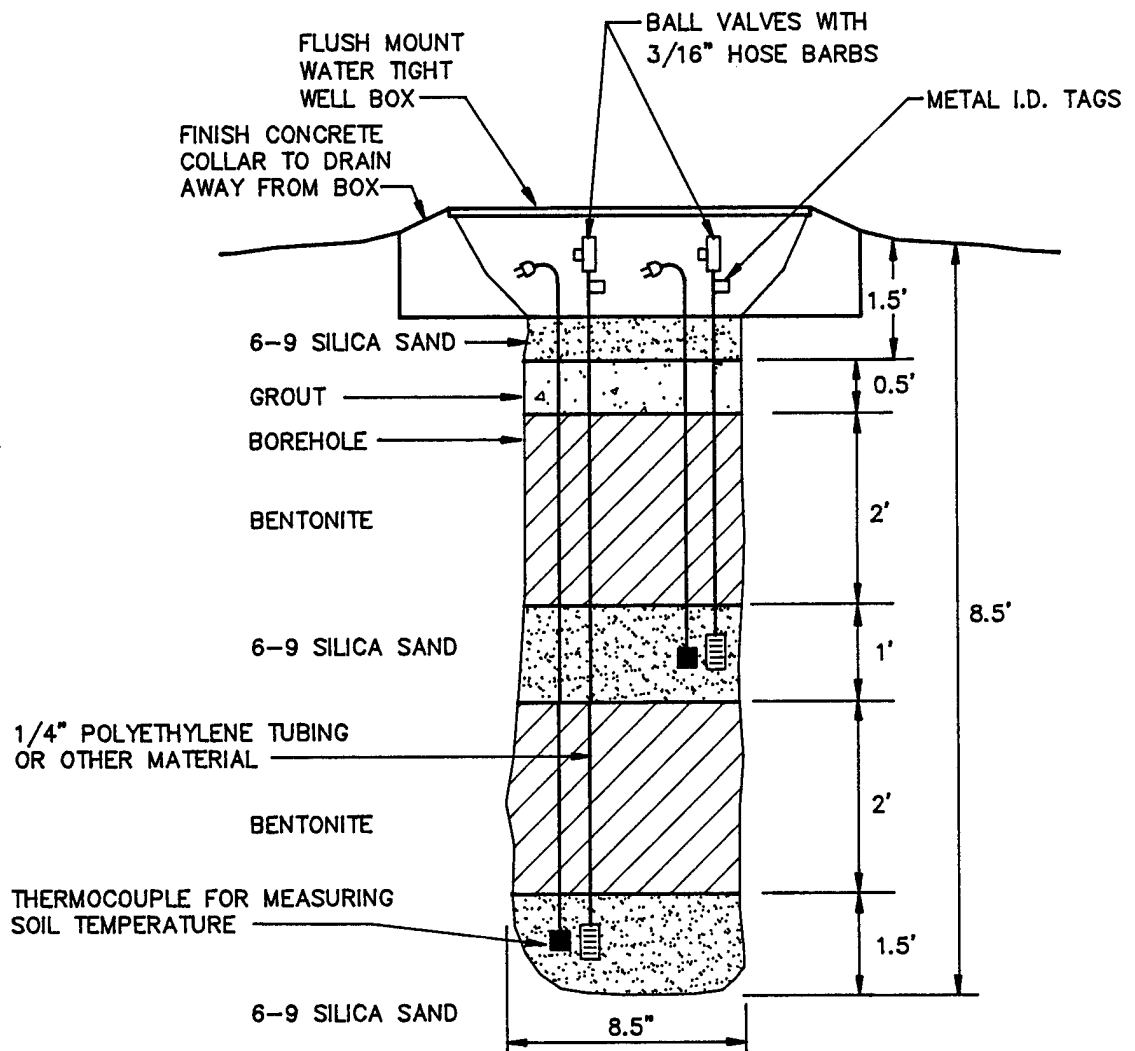

FIGURE 1.4

TYPICAL MONITORING POINT CONSTRUCTION DETAIL

OFFUTT A.F.B., NEBRASKA

ENGINEERING-SCIENCE, INC.
Denver, Colorado

ES

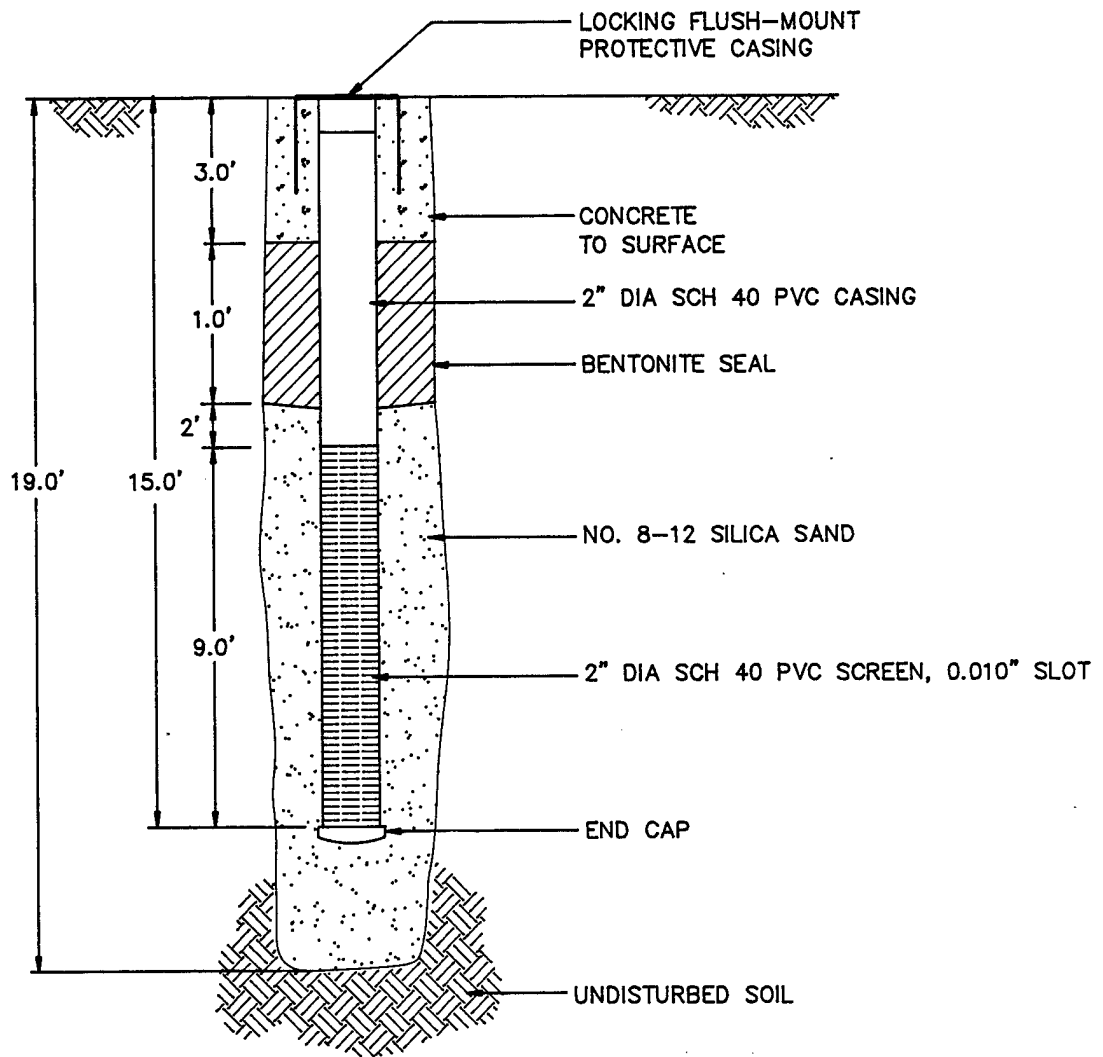

NOT TO SCALE

FIGURE 1.5

MONITORING WELL
LPD-MW1 CONSTRUCTION

OFFUTT A.F.B., NEBRASKA

ENGINEERING-SCIENCE, INC.
Denver, Colorado



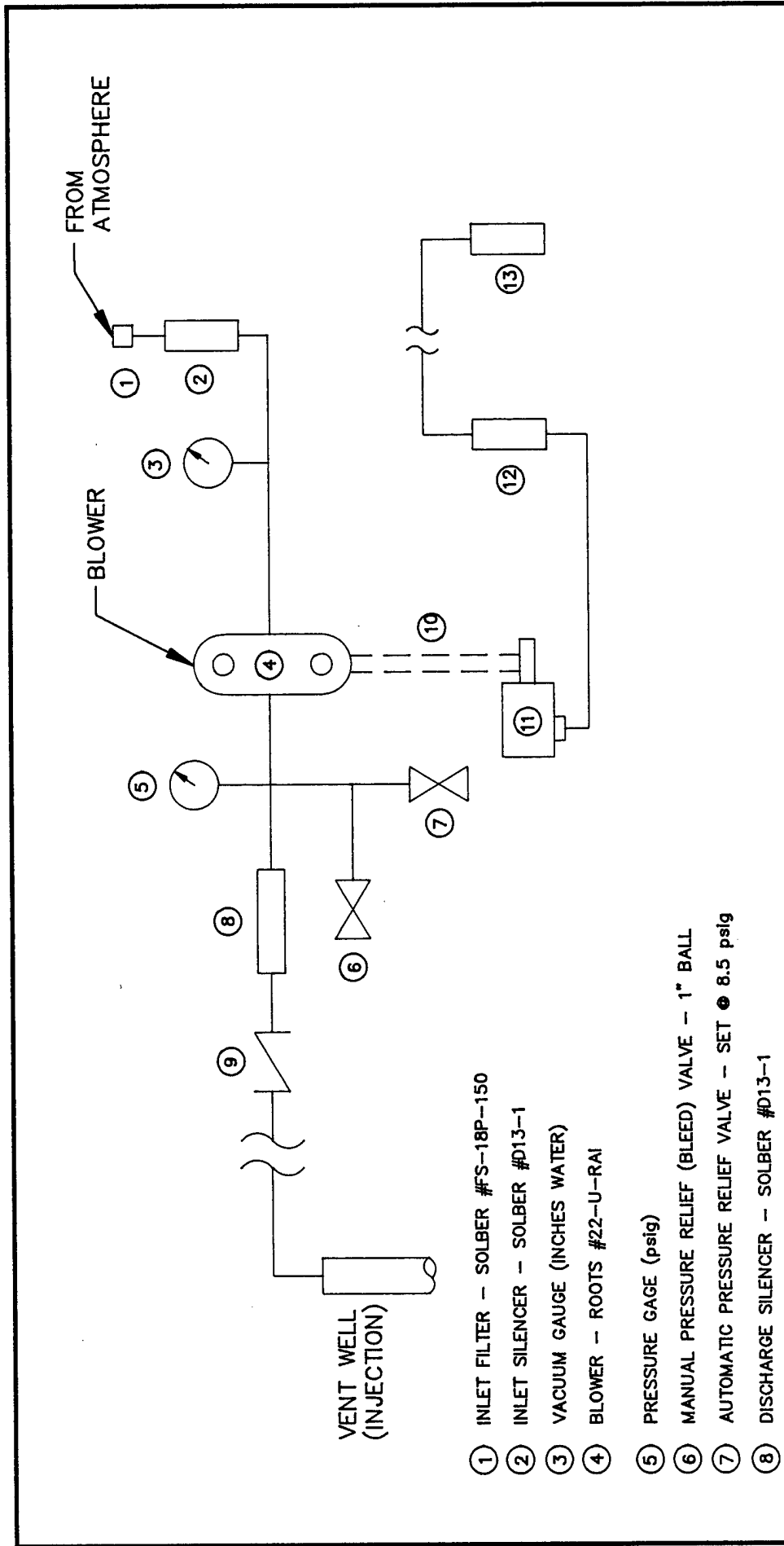

FIGURE 1.6

**AS-BUILT BLOWER SYSTEM
FOR AIR INJECTION**

OFFUTT AFB, NEBRASKA

ENGINEERING-SCIENCE, INC.
Denver, Colorado



- ① INLET FILTER - SOLBER #FS-18P-150
- ② INLET SILENCER - SOLBER #D13-1
- ③ VACUUM GAUGE (INCHES WATER)
- ④ BLOWER - ROOTS #22-U-RAI
- ⑤ PRESSURE GAGE (psig)
- ⑥ MANUAL PRESSURE RELIEF (BLEED) VALVE - 1" BALL
- ⑦ AUTOMATIC PRESSURE RELIEF VALVE - SET @ 8.5 psig
- ⑧ DISCHARGE SILENCER - SOLBER #D13-1
- ⑨ CHECK VALVE - 1"
- ⑩ BELT DRIVE
- ⑪ DRIVE MOTOR
3 HP / 3450 RPM @ 60 Hz / 230 v / SINGLE PHASE / 14.5 A /
FRAME SIZE 145T
- ⑫ STARTER
230 v / 27 A / SINGLE PHASE
- ⑬ BREAKER BOX
230 v / 50 A / SINGLE PHASE

boring logs are included in Appendix B. Ground water occurred at depth of approximately 9 feet in LPD-MW1.

Hydrocarbon contamination at this site was generally observed from 4 feet bgs to the ground water at approximately 9 feet. Contamination was identified based on visual appearance, odor, and volatile organic compound (VOC) field screening results. Heavily contaminated soils were stained dark gray in color and had a strong hydrocarbon odor. Split-spoon samples were screened for VOCs using a photoionization detector (PID) to determine the presence of contamination and to select soil samples for laboratory analyses.

Soil samples for laboratory analyses were collected from O1-VW1 at 4 feet bgs, from O1-MPA at 7 feet bgs, and from O1-MPB at 7 feet bgs. Procedures specified in the "Field Sampling Plan" section of the *Project Management Plan* (Engineering-Science, Inc., 1992) were followed for all soil sampling activities. Soil gas samples were collected by extracting soil gas from LPD-MW1, O1-VW1, and from O1-MPB at 7 feet bgs.

Soil samples were shipped via Federal Express® to the ES Berkeley laboratory for chemical and physical analysis. Soil samples were analyzed for total recoverable petroleum hydrocarbons (TRPH); benzene, toluene, ethylbenzene, and xylenes (BTEX); iron; alkalinity; total kjeldahl nitrogen (TKN); and several physical parameters. Soil gas samples were shipped via Federal Express® to AirToxics, Inc. in Rancho Cordova, California for total petroleum hydrocarbon (TPH) and benzene, toluene, ethylbenzene, and xylenes (BTEX) analysis. The results of these analyses are summarized in Table 2.1. It should be noted that TRPH concentrations were expected to be about 1,000 mg/kg, based on previous site characterization data, but were found to be much lower at the locations and intervals sampled.

In order to document proper sample possession for all samples collected and delivered to the analytical laboratories, a chain-of-custody record was completed with site name, sample numbers, sample date, time of collection, samplers signatures, and analyses to be performed. A copy of this form is included in Appendix B.

2.1 Exceptions to Test Protocol

A soil gas survey was not conducted at this site due to logistical constraints and drilling locations that were limited by utility corridors.

As allowed by the protocol, an existing ground water monitoring well was utilized as the soil gas background well. Monitoring well FT2-MW3 is screened from approximately 5 feet to 20 feet bgs. The most recent water table elevation data from December 1991 show ground water at 9.26 feet bgs.

Due to accelerated respiration rates, the soil gas sampling frequency specified in the protocol document (Hinchee et al., 1992) was increased during the respiration test.

TABLE 2.1
LOW POINT DRAIN AREA
OFFUTT AFB, NEBRASKA
SOIL AND SOIL GAS ANALYTICAL RESULTS

Analyte (Units) ^{a/}	Sample Number-Depth (feet below ground surface)			
<u>Soil Hydrocarbons</u>	<u>O1-VW1-4</u>	<u>O1-MPA-7</u>	<u>O1-MPB-7</u>	<u>O1-SB1-7</u> [*]
TRPH (mg/kg)	37	6	10	7
Benzene (μg/kg)	ND	15	16	36
Toluene (μg/kg)	7,100	22	14	24
Ethylbenzene (μg/kg)	4,100	11	ND	12
Xylenes (μg/kg)	25,000	67	111	54
<u>Soil Gas Hydrocarbons</u>	<u>O1-VW1-A1</u>	<u>LPD-MW1</u>	<u>O1-MPB-7-A1</u>	<u>O1-MPB-11-A1</u> ^{**}
TPH (ppmv)	35,000	25,000	28,000	31,000
Benzene (ppmv)	38	34	140	140
Toluene (ppmv)	210	170	110	120
Ethylbenzene (ppmv)	62	31	11	13
Xylenes (ppmv)	140	62	49	55
<u>Soil Inorganics</u>	<u>O1-VW1-4</u>	<u>O1-MPA-7</u>	<u>O1-MPB-7</u>	<u>O1-SB1-7</u>
Iron (mg/kg)	11,600	5,900	5,510	6,790
Alkalinity (mg/kg as CaCO ₃)	270	380	240	420
pH (units)	7.9	7.9	8.1	7.9
TKN (mg/kg)	380	230	100	49
Phosphates (mg/kg)	530	480	430	460
<u>Soil Physical Parameters</u>	<u>O1-VW1-4</u>	<u>O1-MPA-7</u>	<u>O1-MPB-7</u>	<u>O1-SB1-7</u>
Moisture (% wt.)	19.4	14.9	9.5	18.9
Gravel (%)	1	3	0	0
Sand (%)	24	36	59	61
Silt (%)	50	39	28	28
Clay (%)	25	22	13	11
Temperature (°C)	NA	NA	66.2	NA

a/ mg/kg=milligrams per kilogram, μg/kg = micrograms per kilogram; ppmv=parts per million, volume per volume; CaCO₃=calcium carbonate; TKN=total Kjeldahl nitrogen; °C = degrees Celcius.

b/ ND = not detected.

* Duplicate sample of O1-MPA-7

** Duplicate sample of O1-MPB-7-A1

3.0 TEST RESULTS

3.1 Initial Soil Gas Chemistry

Prior to initiating any air injection, all MPs were purged until oxygen levels had stabilized, and initial oxygen, carbon dioxide, and TVH concentrations were measured using portable gas analyzers, as described in the technical protocol document (Hinchee et al., 1992). Table 3.1 summarizes the initial soil gas chemistry at this site. These field data also demonstrate the relationship between depleted oxygen levels and more highly contaminated soils. In highly contaminated soils, microorganisms had depleted soil gas oxygen supplies. In contrast, the background monitoring well (FT2-MW3), which was thought to be outside the contaminated area, had 16.0 percent oxygen available. A higher oxygen concentration was expected; however, some soil gas contamination (490 ppmv TVH) was detected in this well, suggesting that the measured oxygen levels may not be representative of uncontaminated soils. A more representative background sample will be collected with a hand-driven vapor probe during the second respiration test in March of 1993.

3.2 Soil Gas Permeability

A soil gas permeability test was conducted according to protocol procedures. Air was injected at a rate of approximately 27 scfm and a pressure of 125 inches of water. The maximum pressure response and the calculated air permeability at each MP are listed in Table 3.2. A radius of pressure influence of at least 25 feet was observed. As discussed in the protocol document, the dynamic method of determining soil gas permeability that is coded in the HyperVentilate® model is only appropriate for soils which reach steady state in greater than 10 minutes. In this pilot test, steady state was reached almost 1 hour into the test, and the HyperVentilate® model was used. The resulting calculated permeabilities are listed in Table 1.3. Using the steady-state method, the calculated permeability is 3.37 darcys.

3.3 Oxygen Influence

The depth and radius of oxygen increase in the subsurface resulting from air injection into the central VW during pilot testing is the primary design parameter for full-scale bioventing systems. Optimization of full-scale and multiple VW systems requires pilot testing to determine the volume of soil which can be oxygenated at a given flow rate and VW screen configuration.

Table 3.3 describes the change in soil gas oxygen levels that occurred during the initial 14-hour air-injection test at the LPD site. This relatively brief air injection period produced a radius of oxygen influence of at least 25.5 feet. Based on measured pressure response, which is an indicator of long-term oxygen transport, it is anticipated that the radius of oxygen influence for a long-term bioventing system will also exceed 25 feet using a regenerative blower. Monitoring during the extended pilot test at this site will better define the treatment radius.

TABLE 3.1

**INITIAL SOIL GAS CHEMISTRY
LOW POINT DRAIN AREA
OFFUTT AFB, NEBRASKA**

Monitoring Point	Depth (ft)	O ₂ (%)	CO ₂ (%)	TVH ^{a/} (ppmv) ^{b/}
O1-VW1	3.5 - 8.5	1.6	9.3	>20,000
LPD-MW1	6 - 9	0.0	10.0	>20,000
O1-MPA-4	4	0.0	7.3	>20,000
O1-MPA-7	7	0.0	10.5	>20,000
O1-MPB-4	4	13.0	2.2	>20,000
O1-MPB-7	7	0.1	12.2	>20,000
FT2-MW3	5-20	16.0	5.0	490

a/ TVH = Total Volatile Hydrocarbons.

b/ (ppmv) = Parts per million, volume per volume.

TABLE 3.2**MAXIMUM PRESSURE RESPONSE AND CALCULATED PERMEABILITY
AIR PERMEABILITY TEST
LOW POINT DRAIN AREA
OFFUTT AFB, NEBRASKA**

Monitoring Point	Distance from VW (feet)	Depth (feet)	Maximum Pressure Response (inches H ₂ O)	Calculated Air Permeability (Darcys) ^{a/}
O1-MPA-4	15.5	4	12.8	3.16
O1-MPB-4	25.5	4	0.24	25.48
O1-MPA-7	15.5	7	11.7	19.07
O1-MPB-7	25.5	7	2.95	28.32
LPD-MW1	5.5	6-9	60.0	1514

^{a/} Calculated using Method 2 of the HyperVentilate[®] program.

TABLE 3.3

INFLUENCE OF AIR INJECTION AT VENT WELL
ON MONITORING POINT OXYGEN LEVELS
LOW POINT DRAIN AREA
OFFUTT AFB, NEBRASKA

Monitoring Point	Distance from VW (ft)	Depth (ft)	Initial O ₂ (%)	O ₂ @ 14 Hours (%)
O1-MPA-4	15.5	4	0.0	15.9
O1-MPB-4	25.5	4	13.0	18.7
O1-MPA-7	15.5	7	0.0	16.1
O1-MPB-7	25.5	7	0.1	8.5
LPD-MW1	5.5	6-9	0.0	19.7

3.4 In Situ Respiration Rates

In situ respiration tests are performed by injecting air (oxygen) into several contaminated MPs, and then measuring the biological oxygen uptake over time. The results of *in situ* respiration testing at this site are presented in Figures 3.1 through 3.4. The biological oxygen demand in O1-VW1, O1-MPA-7, O1-MPB-7, and LPD-MW1 ranged from 0.011 to 0.018 percent per minute during the initial 1000 minutes of testing. The average oxygen utilization rate for the four MPs is 0.014 percent per minute.

A 1-percent mixture of helium in air was injected into O1-MPB-7. Because helium is a conservative, inert gas, the change in helium concentrations over time can be useful in determining if oxygen diffusion is responsible for a portion of the oxygen lost from each MP. Figure 3.5 compares oxygen utilization and helium retention for MP O1-MPB-7. Although helium was never recovered at the 1 percent helium injection concentration, no trend indicating helium loss was observed. The lower than expected initial readings may have been due to sampling procedures. The rise in helium concentrations between 800 and 1,400 minutes may be due to variable injection concentrations. Although the data are somewhat variable, they demonstrate that no significant diffusion of helium occurred, as the initial reading was 0.58 percent and the reading after 1,715 minutes was 0.50 percent (Figure 3.5). Because there is no evidence of helium diffusion, and oxygen diffuses more slowly than helium, oxygen diffusion during the test is considered negligent. Therefore, it was inferred that the oxygen utilization rates observed during the respiration test were due primarily to biological activity.

Based on oxygen utilization rates observed during the initial 1000 minutes of respiration testing, an estimated 3,100 to 5,000 milligrams (mg) of fuel per kilogram (kg) of soil can be degraded each year at this site. This estimate is based on an average air-filled porosity of 0.14 liters per kilogram of soil, and a conservative ratio of 3.5 mg of oxygen consumed for every 1 mg of fuel biodegraded. If these rates of biodegradation can be sustained, the time required to remediate known TRPH concentrations at this site estimated at less than 1 year.

3.5 Potential Air Emissions

Soil concentrations of BTEX compounds detected were less than 40 mg/kg. Based on these BTEX concentrations, the long-term potential for air emissions from full-scale bioventing operations at this site is moderate. Initial emissions should be minimal because accumulated vapors will move slowly outward from the air injection point and will be biodegraded as they move horizontally through the soil.

4.0 RECOMMENDATIONS

Initial bioventing tests at this site indicate that oxygen has been depleted in contaminated soils at the LPD site and that air injection is an effective method of increasing aerobic fuel biodegradation. AFCEE recommends that pilot-scale air injection continue in order to determine the long-term radius of oxygen influence and effects of time, available nutrients, and changing soil temperatures on fuel biodegradation rates.

Figure 3.1
 Respiration Test
 Monitoring Point O1-VW1
 Offutt AFB, Omaha, NE

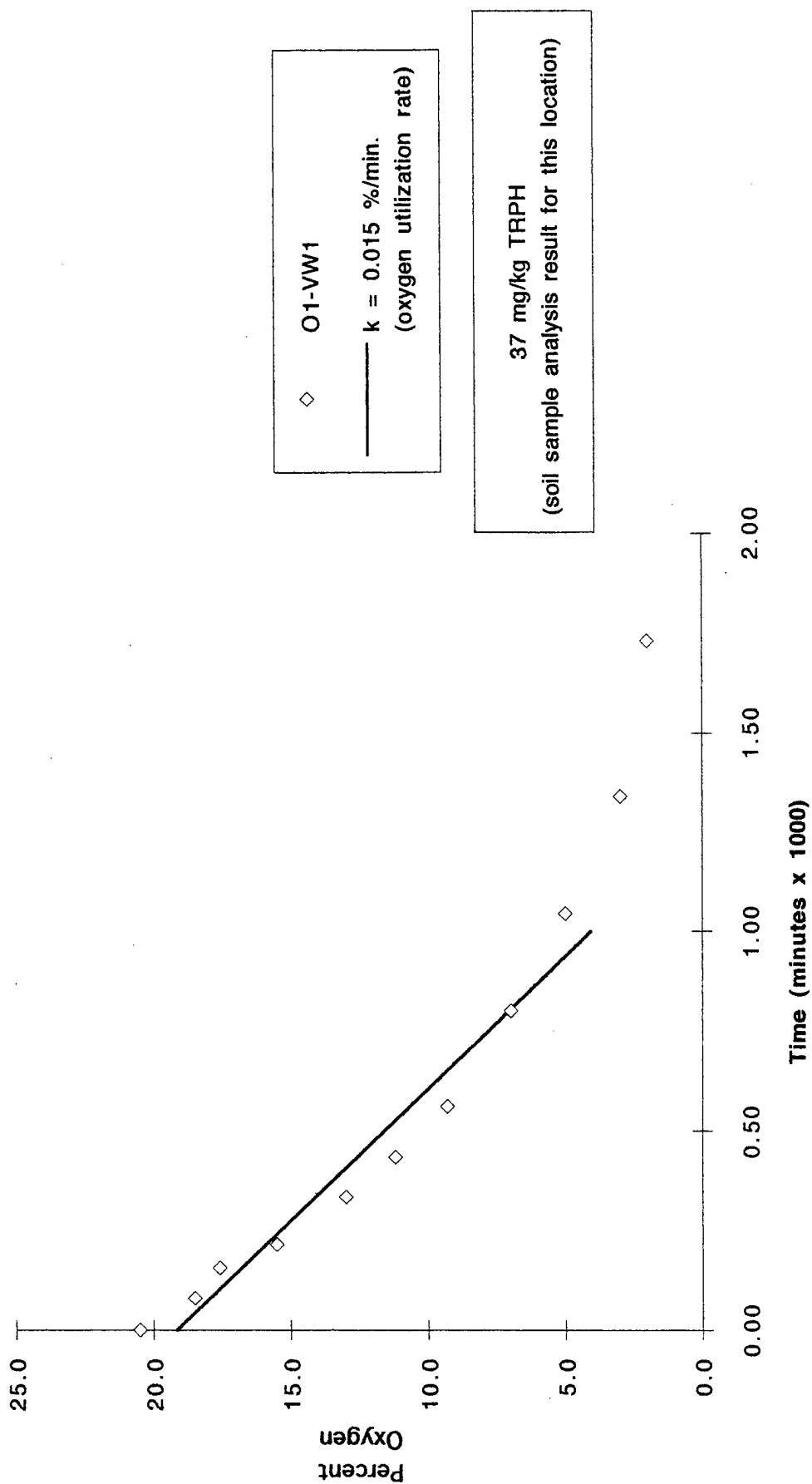

Figure 3.2
 Respiration Test
 Monitoring Point LPD-MW1
 Offutt AFB, Omaha, NE

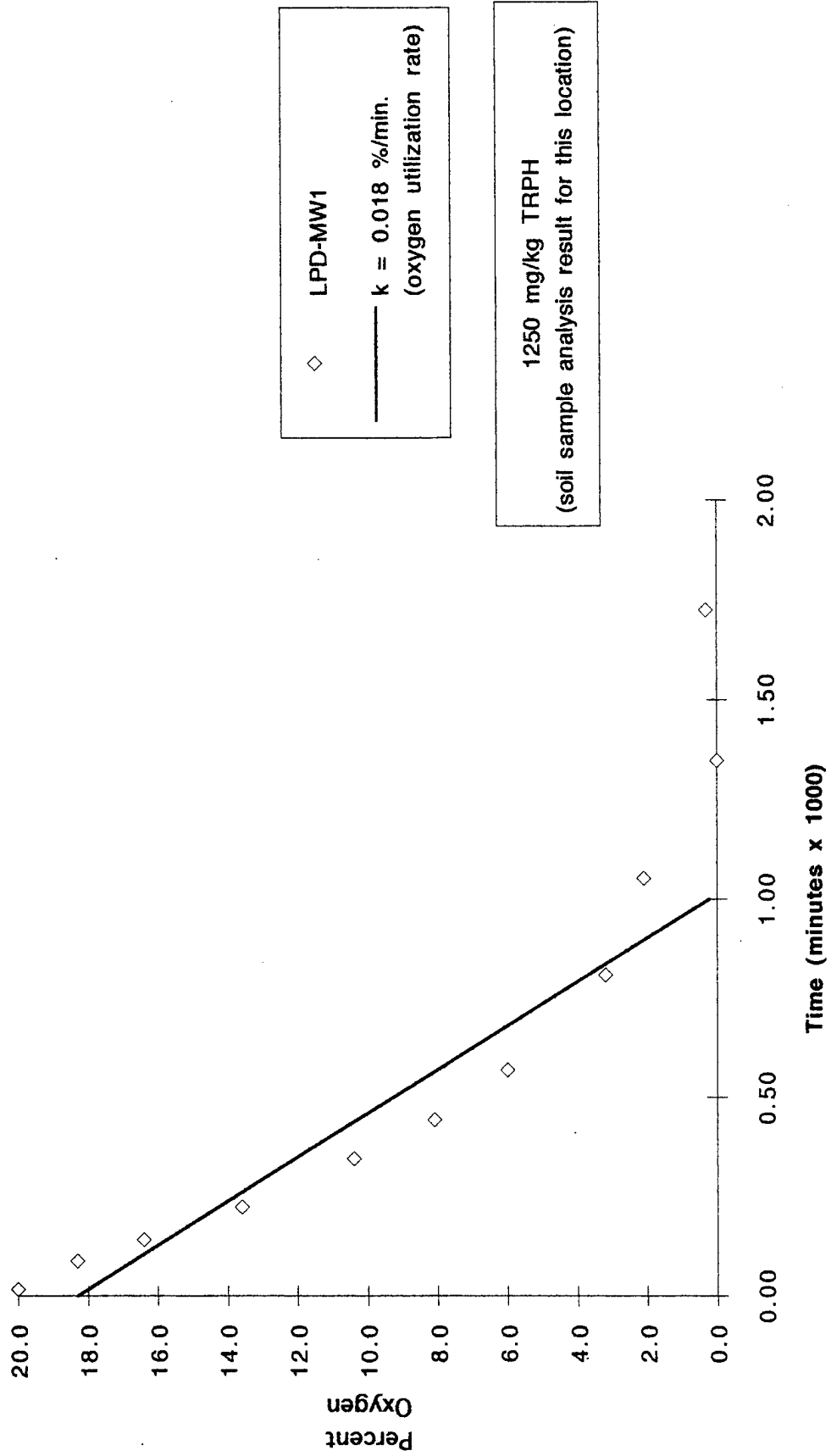

Figure 3.3
 Respiration Test
 Monitoring Point O1-MPA-7
 Offutt AFB, Omaha, NE

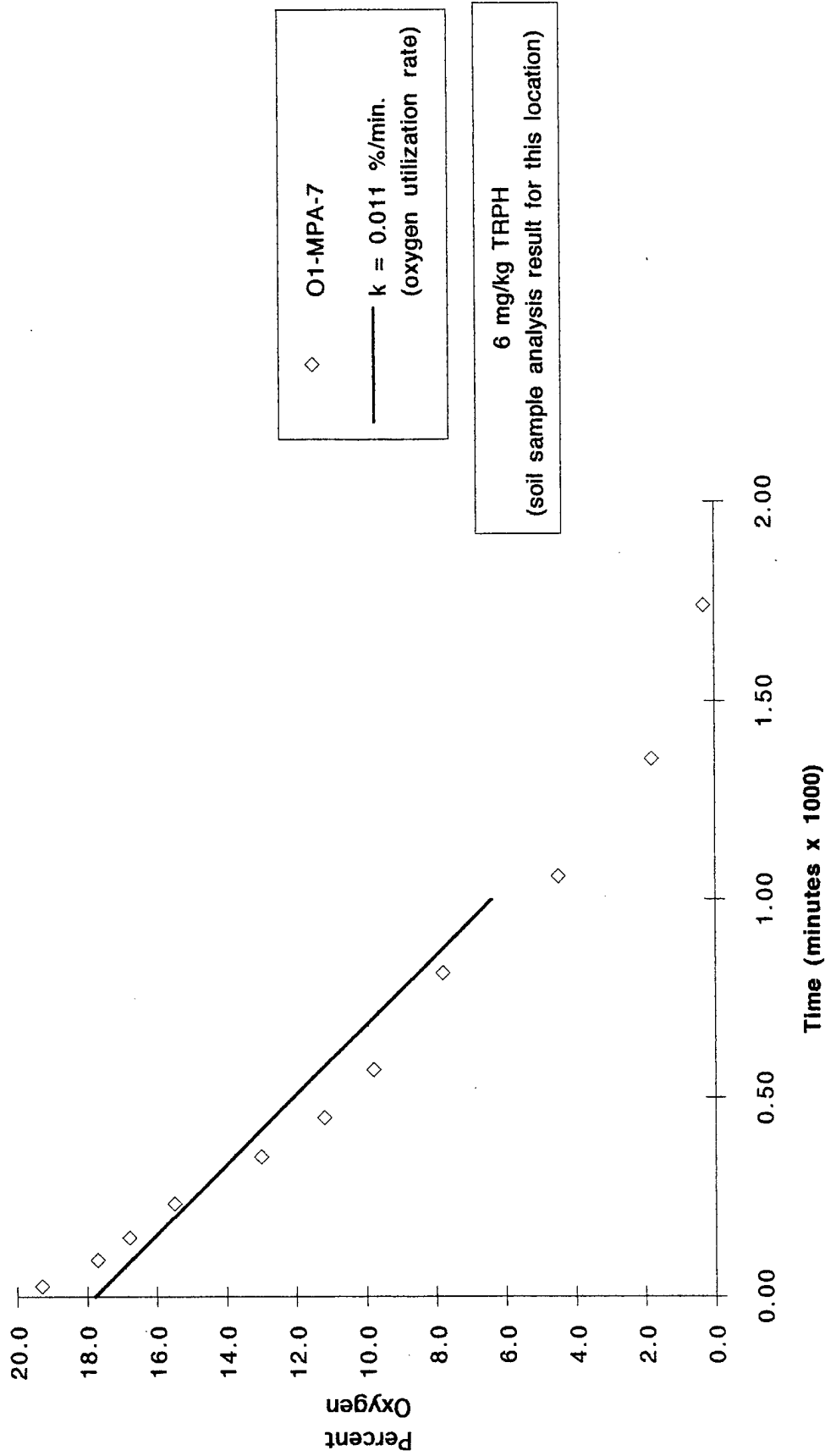

Figure 3.4
 Respiration Test
 Monitoring Point O1-MPB-7
 Offutt AFB, Omaha, NE

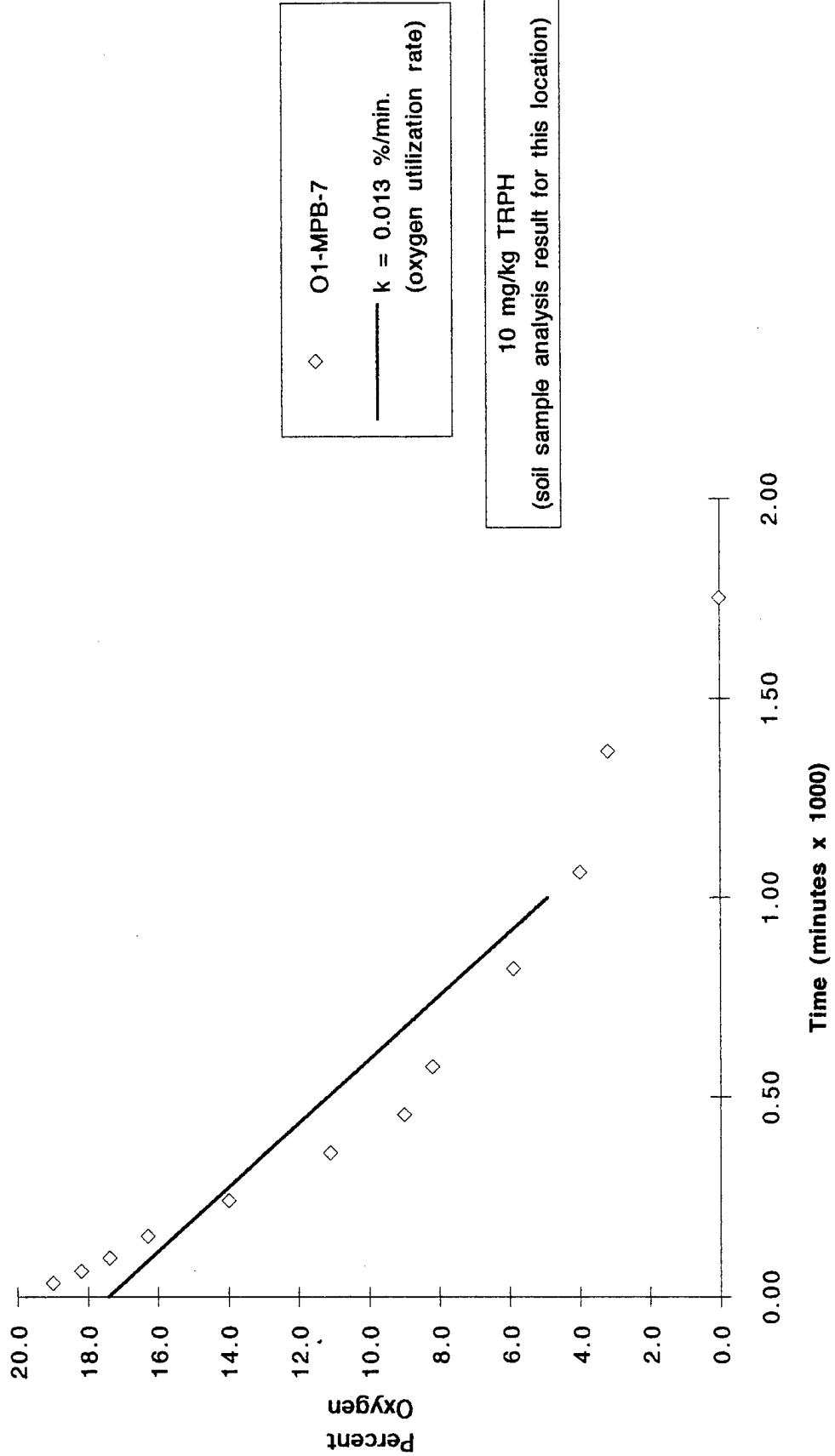
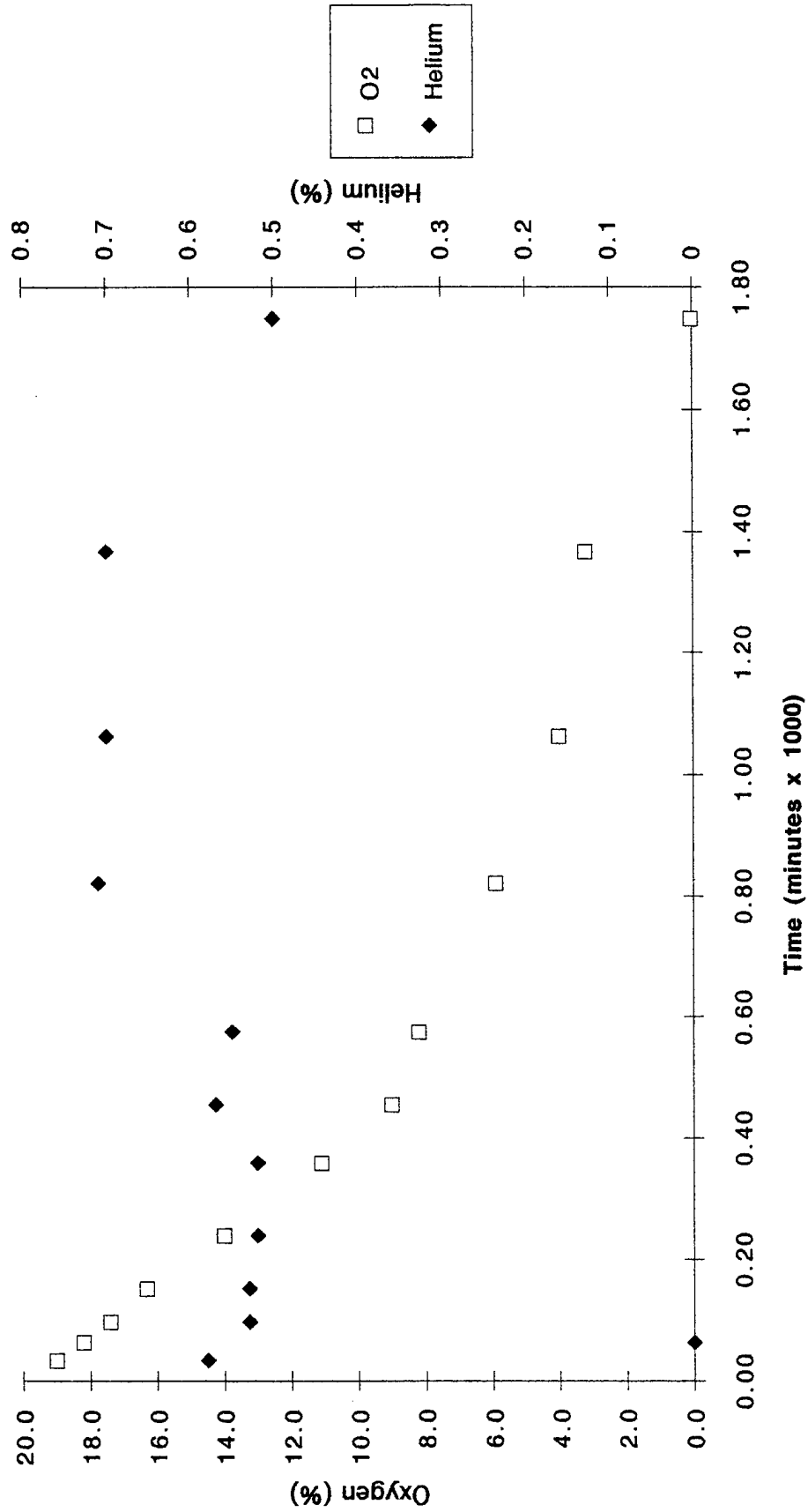

Figure 3.5
 Respiration Test
 Oxygen and Helium Concentrations
 Monitoring Point O1-MPB-7
 Offutt AFB, Omaha, NE



A small blower has been installed at the site to continue a low rate of air injection. In November 1992, this blower will be replaced with a more efficient regenerative blower. The new blower will inject air for an additional 9 months. In March of 1993, ES will return to the site to conduct a repeat respiration test. In August of 1993, a final respiration test will be conducted, and soil and soil gas samples will be collected from the site to determine the degree of remediation achieved during the first year.

Based on the results of the first year of pilot-scale bioventing, AFCEE will recommend one of three options:

1. Upgrade and continue operation of the bioventing system for full-scale remediation of the site. AFCEE can assist the base in obtaining regulatory approval for upgrading and continuing system operation.
2. If final soil sampling indicates significant contaminant removal has occurred, AFCEE may recommend additional sampling to confirm that cleanup criteria have been achieved.
3. If significant difficulties or poor results are encountered during bioventing at this site, AFCEE may recommend removal of the blower system and proper abandonment of the VW.

REFERENCES

Engineering-Science, Inc. 1992. Project Management Plan; AFCEE Bioventing Pilot Tests. April, 1992. Denver, Colorado.

Hinchee, R.E., R.N. Miller, and D.C. Downey. 1992. Test Plan and Technical Protocol for a Field Treatability Test for Bioventing. Prepared for USAF Center for Environmental Excellence. May.

APPENDIX A
BLOWER MAINTENANCE SCHEDULE AND
O & M CHECKLIST

BLOWER MAINTENANCE SCHEDULE

OFFUTT AFB, NEBRASKA

DAILY MAINTENANCE

Check to see if blower is running; no need to open enclosure. If blower is not running, have base electrician verify that power is available at the starter, then contact ES.

WEEKLY MAINTENANCE

Pressure/Vacuum/Temperature Measurements

Record readings from the outlet pressure, inlet vacuum, and outlet temperature gages, with blower running, along with the date on a data collection sheet.

Lubrication

1. Add grease to the two grease fittings until grease begins coming out of relief fittings.
2. Check oil level.
 - a. Stop motor.
 - b. Remove "breather" and oil overflow plugs.
 - c. Add oil until it begins coming out of overflow. (Use SAE 40 nondetergent oil in summer and SAE 30 nondetergent oil in winter)
 - d. Start motor. Open manual pressure-relief valve, start motor, slowly close pressure-relief valve.

Miscellaneous

Note any unusual noise or vibration and contact ES. Visually check drive belt for signs of wear, replace if required (see Generic Operations and Maintenance Manual).

MONTHLY MAINTENANCE

1. Change oil in blower (see Generic Operations and Maintenance Manual).
2. Check drive belt tension, adjust as necessary (see Generic Operations and Maintenance Manual).

PERIODIC MAINTENANCE

Change air filter when inlet vacuum exceeds 15 inches of water. Also contact ES.

ES CONTACTS: MR. JIM WALTERS, MR. BRIAN BLICKER (303) 831-8100.

APPENDIX B
GEOLOGIC BORING LOGS
AND
CHAIN-OF-CUSTODY FORMS

GEOLOGIC BORING LOG

JOB NUMBER: DE268.10	CLIENT: AFCEE - OFFUTT AFB	DATE: 12-AUG-92
BORING NO.: O1-MPA	BORING DIA.: 8 1/2"	ELEV: -
MACH. TYPE: CME 75	CONTRACTOR: SITE SERVICES	DATUM: GROUND SURFACE
TEMP (°F): 70	WEATHER: CLDY, WARM	GEOLOGIST: JEW
	DRLNG MED: NONE	

Depth (ft.)	Pro-file	US CS	Geological Description	Samples		Sample Type	Drill Pres./ Blow Counts	Remarks
				No.	Depth (ft)			
1	5	CL	Med. Brn silty-CLAY, tr sand, sl moist	O1-MPA-7	7-9	S	4,11	
	5							
	5							
	5							
5	5							
	5							
	5							
	5							
	5							
	5							
		CL	SAA to 7.0'					PID: 0.1/1.0
		SW	Med. Grey fine to med SAND, wet lower 1/2 of sample					PID: 0.0/81.3 (ppmv) TD @ 8.5'
10								----- @ 9.0'

w - with	sl - slight	S SPLIT SPOON SAMPLE
sm - some	v - very	G GRAB SAMPLE
tr - trace	SAA - Same As Above	 UNDISTRUBED SAMPLE

ENGINEERING CHAIN OF CUSTODY RECORD

ES JOB NO.	PROJECT NAME/LOCATION	FIELD CONTACT:	SAMPLERS NAMES & SIGNATURES	DATE	TIME	FIELD SAMPLE IDENTIFIER	TKN (351.2)	T. phosphate (365.3)	Ucm (class) sizer	ANALYSES REQUIRED	PRESERVATIVES REQUIRED	SHIP TO:	REMARKS
1	W.O. # 4245	Reddy Chibano		8/12/92	1015	01-V01-4	X	X	X	4245-1C	2082427	Saguia Analytical	-Sub-Dept -
					1400	01-MPA-7	X	X	X	4245-2C	28		Report results on dry soil basis. Use mbd's for reporting units.
					1130	01-MPB-7	X	X	X	4245-3C	29		Report method blank, MS/MSD. 10 day
					1500	01-SB1-7	X	X	X	4245-4C	30		Report TAT. Report results to T. Hudson. ESBL.

DATE: 8/14/92 TIME: 10:30
 DATE: 8/14/92 TIME: 12:40 PM
 ON RECEIPT: CUSTODY SEALS? ; TEMP: °C
 AIRBILL #
 SHIPPED VIA:
 FIELD CUSTODY RELINQUISHED BY: Ruby Chit
 FIVED FOR LABORATORY BY: [Signature] 8/14/92 1:45 PM
 SHD BY: [Signature] 8/14/92 1:45 PM

