

# LOAN DOCUMENT

PHOTOGRAPH THIS SHEET

0

INVENTORY

DTIC ACCESSION NUMBER

LEVEL

2 Part's

Bioventing Pilot Test Work Plan for PS-3...

DOCUMENT IDENTIFICATION

Dec 93

## DISTRIBUTION STATEMENT A

Approved for Public Release  
Distribution Unlimited

DISTRIBUTION STATEMENT

DATE ACCESSIONED

DATE RETURNED

REGISTERED OR CERTIFIED NUMBER

ACCESSION FOR	
NTIS	GRAM
DTIC	TRAC
UNANNOUNCED	
JUSTIFICATION	
BY	
DISTRIBUTION/	
AVAILABILITY CODES	
DISTRIBUTION	AVAILABILITY AND/OR SPECIAL
A-1	

DISTRIBUTION STAMP

DTIC QUALITY INSPECTED 4

20010117 008

DATE RECEIVED IN DTIC

PHOTOGRAPH THIS SHEET AND RETURN TO DTIC-FDAC

H  
A  
N  
D  
L  
E  
  
W  
I  
T  
H  
  
C  
A  
R  
E

# **PART I**

**Bioventing Pilot Test Work Plan for  
PS-3 (Pumphouses 2 and 3) and  
PS-4 (Bulk POL Storage Area)  
Malmstrom AFB, Montana**

# **PART II**

**Draft Interim Pilot Test Results Report for  
PS-3 (Pumphouses 2 and 3) and  
PS-4 (Bulk POL Storage Area)  
Malmstrom AFB, Montana**

Prepared For

**Air Force Center for Environmental Excellence  
Brooks AFB, Texas**

and

**43 CES/CEVR  
Malmstrom AFB, Montana**

**ES**

**Engineering-Science, Inc.**

1700 BROADWAY, SUITE 900  
DENVER, COLORADO 80290

December 1993

**ES ENGINEERING-SCIENCE**

*AQ M01-03-0931*

### DEFENSE TECHNICAL INFORMATION CENTER REQUEST FOR SCIENTIFIC AND TECHNICAL REPORTS

Title AFCEE Collection

1. Report Availability (Please check one box)	2a. Number of Copies Forwarded	2b. Forwarding Date
<input checked="" type="checkbox"/> This report is available. Complete sections 2a - 2f. <input type="checkbox"/> This report is not available. Complete section 3.	<u>1 each</u>	<u>July/2000</u>

2c. Distribution Statement (Please check ONE box)

*DoD Directive 5230.24, "Distribution Statements on Technical Documents," 18 Mar 87, contains seven distribution statements, as described briefly below. Technical documents MUST be assigned a distribution statement.*

DISTRIBUTION STATEMENT A: Approved for public release. Distribution is unlimited.

DISTRIBUTION STATEMENT B: Distribution authorized to U.S. Government Agencies only.

DISTRIBUTION STATEMENT C: Distribution authorized to U.S. Government Agencies and their contractors.

DISTRIBUTION STATEMENT D: Distribution authorized to U.S. Department of Defense (DoD) and U.S. DoD contractors only.

DISTRIBUTION STATEMENT E: Distribution authorized to U.S. Department of Defense (DoD) components only.

DISTRIBUTION STATEMENT F: Further dissemination only as directed by the controlling DoD office indicated below or by higher authority.

DISTRIBUTION STATEMENT X: Distribution authorized to U.S. Government agencies and private individuals or enterprises eligible to obtain export-controlled technical data in accordance with DoD Directive 5230.25, Withholding of Unclassified Technical Data from Public Disclosure, 6 Nov 84.

2d. Reason For the Above Distribution Statement (in accordance with DoD Directive 5230.24)

2e. Controlling Office	2f. Date of Distribution Statement Determination
<u>HQ AFCEE</u>	<u>15 Nov 2000</u>

3. This report is NOT forwarded for the following reasons. (Please check appropriate box)

It was previously forwarded to DTIC on ..... (date) and the AD number is .....

It will be published at a later date. Enter approximate date if known. ....

In accordance with the provisions of DoD Directive 3200.12, the requested document is not supplied because:  
.....  
.....

Print or Type Name	Signature
<u>Laura Peña</u>	<u>Laura Peña</u>
Telephone	(For DTIC Use Only) AQ Number
<u>210-536-1431</u>	<u>M01-03-0731</u>

**PART I**

**BIOVENTING PILOT TEST WORK PLAN FOR  
PS-3 (PUMPHOUSES 2 AND 3) AND  
PS-4 (BULK POL STORAGE AREA)**

**MALMSTROM AFB, MONTANA**

Prepared for:

Air Force Center for Environmental Excellence  
Brooks AFB, Texas

and

43 CES/CEVR  
Malmstrom AFB, Montana

Prepared by:

Engineering-Science, Inc.  
1700 Broadway, Suite 900  
Denver, Colorado

December 1993

## CONTENTS

### PART I - BIOVENTING PILOT TEST WORK PLAN FOR PS-3 (PUMPHOUSES 2 AND 3) AND PS-4 (BULK POL STORAGE AREA) MALMSTROM AFB, MONTANA

	<u>Page</u>
1.0 Introduction .....	I-1
2.0 Site Description .....	I-2
2.1 PS-3 Pumphouse 2 .....	I-2
2.1.1 Site History and Location .....	I-2
2.1.2 Site Geology.....	I-2
2.1.3 Site Contaminants .....	I-2
2.2 PS-3 Pumphouse 3 .....	I-2
2.2.1 Site History and Location .....	I-2
2.2.2 Site Geology.....	I-5
2.2.3 Site Contaminants .....	I-5
2.3 PS-4 Bulk POL Storage Area.....	I-5
2.3.1 Site History and Location .....	I-5
2.3.2 Site Geology.....	I-5
2.3.3 Site Contaminants .....	I-5
3.0 Pilot Test Activities .....	I-5
3.1 Vent Wells.....	I-8
3.2 Monitoring Points .....	I-8
3.3 Background Well .....	I-11
3.4 Handling of Drill Cuttings .....	I-11
3.5 <i>In Situ</i> Respiration Tests.....	I-11
3.6 Air Permeability Tests .....	I-12
3.7 Blower System .....	I-12
3.8 Soil and Soil Gas Sampling .....	I-12
3.8.1 Soil Samples.....	I-12
3.8.2 Soil Gas Samples .....	I-14
4.0 Exceptions to Protocol Procedures.....	I-14
5.0 Base Support Requirements .....	I-14
6.0 Project Schedule.....	I-15
7.0 Points of Contact .....	I-16
8.0 References .....	I-16

## FIGURES

<u>No.</u>	<u>Title</u>	<u>Page</u>
2.1	Site Locations with Respect to Base .....	I-3
2.2	PS-3, Pumphouse 2 - Vent Well, Soil Boring, and Monitoring Well Locations.....	I-4
2.3	PS-3, Pumphouse 3 - Vent Well, Soil Boring, and Monitoring Well Locations.....	I-6
2.4	PS-4, Bulk POL Storage Area - Vent Well, Soil Boring, and Monitoring Well Locations .....	I-7
3.1	Typical Injection Vent Well Construction Detail .....	I-9
3.2	Typical Monitoring Point Construction Detail .....	I-10
3.3	Typical Blower System Instrumentation Diagram for Air Injection .....	I-13

**PART I**  
**BIOVENTING PILOT TEST WORK PLAN FOR**  
**PS-3 (PUMPHOUSES 2 AND 3) AND**  
**PS-4 (BULK POL STORAGE AREA)**  
**MALMSTROM AFB, MONTANA**

**1.0 INTRODUCTION**

This work plan presents the scope of multiphase bioventing pilot tests for *in situ* treatment of fuel-contaminated soils at PS-3 (Pumphouses 2 and 3) and PS-4 [Bulk Petroleum, Oils, and Lubricants (POL) Storage Area] at Malmstrom Air Force Base (AFB) (the Base), Montana. The pilot tests will be performed by Engineering-Science, Inc. (ES). The three primary objectives of the proposed pilot tests are:

- To assess the potential for supplying oxygen throughout the contaminated soil interval,
- To determine the rate at which indigenous microorganisms will degrade fuel when supplied with oxygen-rich soil gas, and
- To evaluate the potential for sustaining these rates of biodegradation until fuel contamination is remediated to concentrations below regulatory standards.

The pilot tests will be conducted in two phases. The initial phase will consist of construction of a vent well (VW) and vapor monitoring points (MPs), an *in situ* respiration test, and an air permeability test at each site. VWs were installed during site investigation activities performed by HDR, Inc. (1993) of Omaha, Nebraska. Vapor MPs will be installed by ES during the initial pilot test. This initial testing is expected to take approximately 3 weeks to complete. A blower system for air injection will be installed at the end of the first phase. During the second phase, the bioventing systems will be operated and monitored over a 1-year period.

If bioventing proves to be an effective means of remediating soil contamination at these sites, pilot test data may be used to design full-scale remediation systems and to estimate the time required for site cleanup. An added benefit of the pilot testing at these sites is that a significant amount of the fuel contamination should be biodegraded during the 1-year pilot test, as the testing will take place within the most contaminated soils at the sites.

Additional background information on the development and recent success of bioventing technology is found in the document entitled *Test Plan and Technical Protocol for a Field Treatability Test for Bioventing* (Hinchee et al., 1992). This

protocol document will serve as the primary reference for pilot test well designs and the detailed procedures to be used during the test.

## **2.0 SITE DESCRIPTION**

### **2.1 PS-3 Pumphouse 2**

#### **2.1.1 Site History and Location**

PS-3 [also referred to as Installation Restoration Program (IRP) site ST 04] consists of fuel Pumphouses 2 and 3. Pumphouse 3 is described in Section 2.2 of this document. A bioventing pilot test will be performed at Pumphouse 2 (Building 245), located northeast of the intersection of Avenue I and First Street (Figure 2.1). In addition to the pumphouse building, there are one 2,000-gallon and six 50,000-gallon underground storage tanks (USTs) at the site (Figure 2.2). Four of the 50,000-gallon USTs are out of service. The remaining two tanks contain unleaded MOGAS and a deicing glycol solution. The 2,000-gallon UST is active and is used to store waste fuels collected in Pumphouse 2 (Woodward-Clyde Consultants, 1993). Five of the 50,000-gallon USTs have been used to store diesel fuel (Battelle Columbus Division, 1988).

A leaking underground fuel transfer line is the suspected source of contamination at Pumphouse 2. An excavation in the area of the line in 1984 discovered diesel fuel contamination. Another fuel line leaked approximately 300 gallons of JP-4 jet fuel (JP-4) in the same general area in 1973 and 1974. Soils contaminated by this release were not excavated (JRB Associates, 1985).

#### **2.1.2 Site Geology**

Because the bioventing technology is applied to the unsaturated soils, this section will primarily discuss soils above the shallow aquifer. Soils in this region of the Base are primarily sandy clay and clay. Soil borings within the vicinity of Pumphouses 2 and 3 encountered primarily clay. Surface soil within the pumphouse enclosure consists of fill material (Woodward-Clyde Consultants, 1993). Other sources indicate that a sandy silt may overlay the clay (Battelle Columbus Division, 1988). Perched seasonal groundwater is known to exist in the vicinity at 3.6 to 4.2 feet below ground surface (bgs) (JRB Associates, 1985 and Battelle Columbus Division, 1988). Information on the depth to the local aquifer was not available.

#### **2.1.3 Site Contaminants**

Diesel fuel contamination has been documented at Pumphouse 2. JP-4 contamination is possible due to a documented pipeline leak in 1973 and 1974 (JRB Associates, 1985). Previous site investigations have detected concentrations of petroleum hydrocarbons up to 2,390 milligrams per kilogram (mg/kg) at 4 feet bgs and 10,100 mg/kg in near-surface soil samples (Woodward-Clyde Consultants, 1993).

### **2.2 PS-3 Pumphouse 3**

#### **2.2.1 Site History and Location**

Pumphouse 3 is located east of the intersection of First Street and Avenue D (Figure 2.1). The pumphouse is configured identically to Pumphouse 2, described in Section

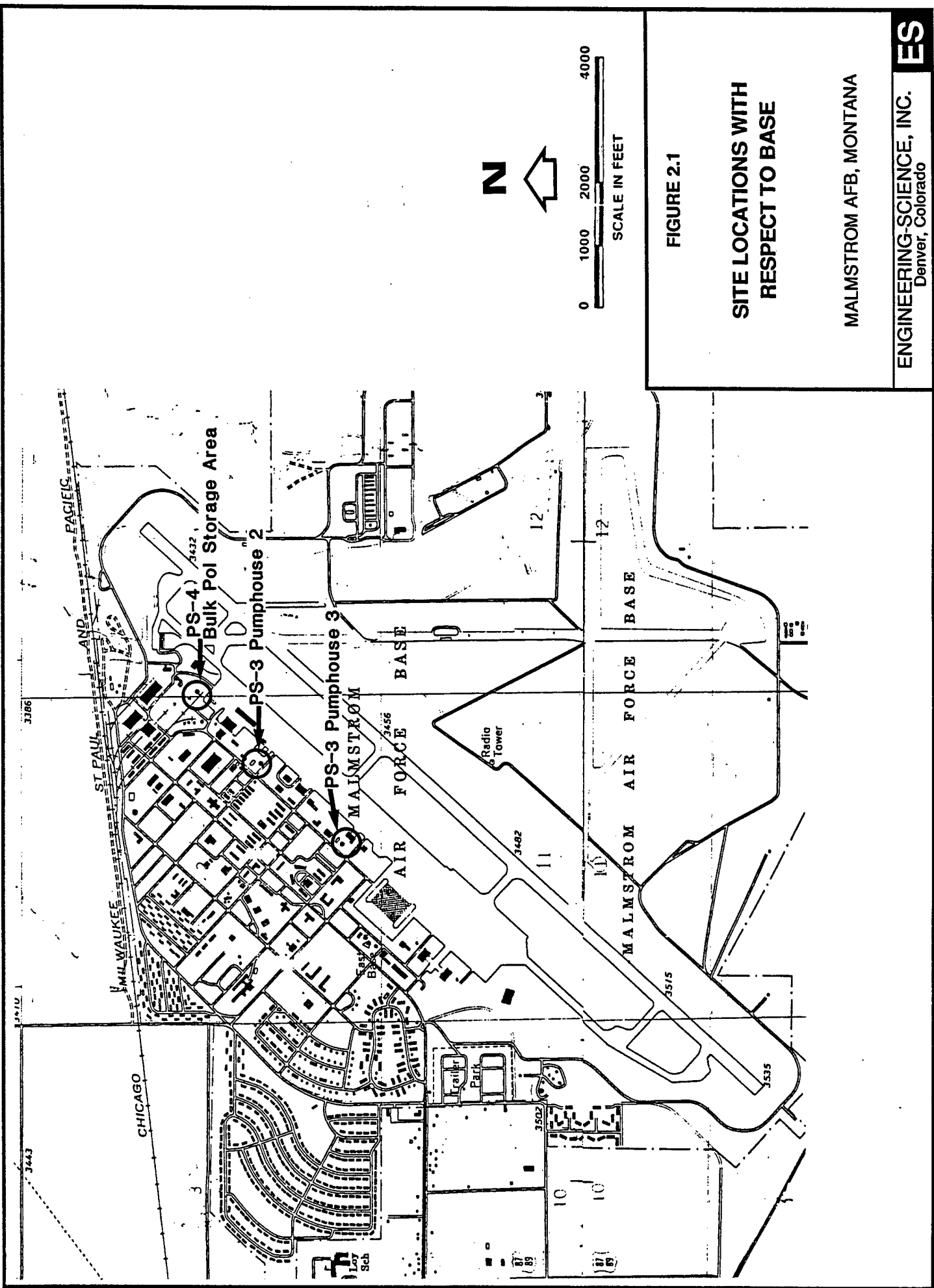

FIGURE 2.1

SITE LOCATIONS WITH  
RESPECT TO BASE

MALMSTROM AFB, MONTANA

ENGINEERING-SCIENCE, INC.  
Denver, Colorado

ES

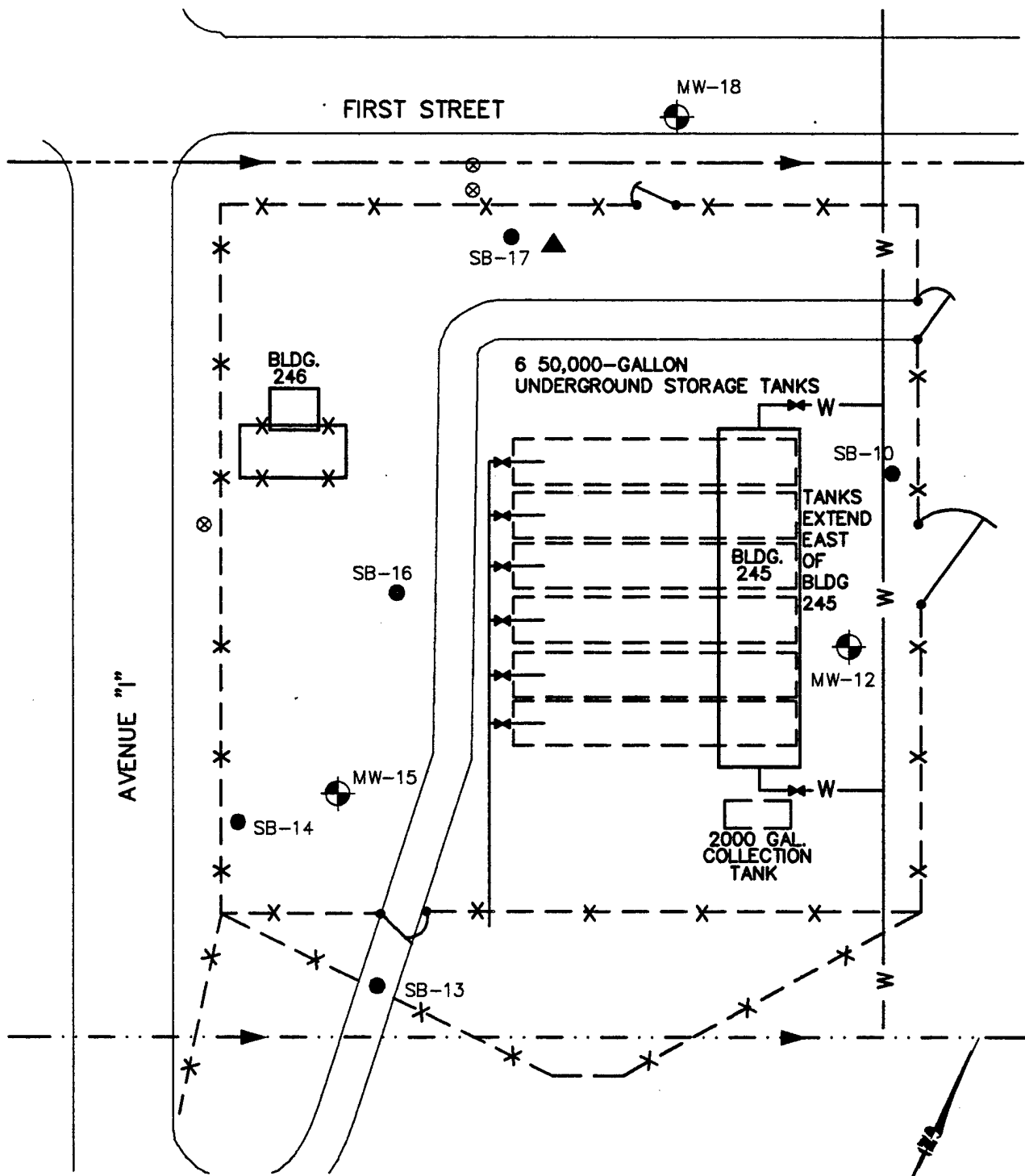

NOT TO SCALE

**LEGEND**

- ▲ VENT WELL
- ⊕ MW-18 MONITORING WELL
- SB-17 SOIL BORING
- W — WATER LINE
- · · · — 10" STORM DRAIN
- — — — DRAINAGE DITCH
- X — X — CHAIN LINK FENCE
- ⊗ POWER POLE

NOTE: ALL WELL AND SOIL BORING LOCATIONS ARE APPROXIMATE.

**FIGURE 2.2**

**PS-3, PUMPHOUSE 2  
VENT WELL, SOIL BORING,  
AND MONITORING WELL  
LOCATIONS**

Malmstrom AFB, Montana

**ENGINEERING-SCIENCE, INC.**

Denver, Colorado

2.1 of this document (Figure 2.3). Three of the six 50,000-gallon USTs store JP-4. The remaining tanks are inactive. A 2,000-gallon UST, formerly used to store waste fuels, is also inactive. No information regarding historical releases is available for Pumphouse 3 (Woodward-Clyde Consultants, 1993).

### **2.2.2 Site Geology**

Little geological information for Pumphouse 3 could be located. Generally, soils in this region of the Base are sandy clay and clay. Soil borings within the vicinity of PS-3 encountered primarily clay (Woodward-Clyde Consultants, 1993). Other sources indicate that a sandy silt may overlay the clay (Battelle Columbus Division, 1988).

### **2.2.3 Site Contaminants**

Although the tanks remaining in service are known to contain JP-4, no data exist to indicate whether other potential contaminants may be present at the site. In general, petroleum hydrocarbon contamination is expected to be present.

## **2.3 PS-4 Bulk POL Storage Area**

### **2.3.1 Site History and Location**

The Bulk POL Storage Area is located at the northeast corner of the Base (Figure 2.1). The storage facility consists of three steel, aboveground storage tanks (ASTs) that are the holding tanks of an extensive fuel dispensing system [Science Applications International Corporation (SAIC, 1991)]. The tanks have a capacity of 10,000 barrels each and contain diesel fuel and JP-4 (SAIC, 1991). Seven USTs that historically contained AVGAS are located southwest of the ASTs (Figure 2.4). The VW at the site was installed between the ASTs and the USTs.

In 1980, two leaks from underground pipelines were reported. Each leak released approximately 100 gallons of JP-4 (Battelle Columbus Division, 1988).

### **2.3.2 Site Geology**

Soils at the Bulk POL Storage Area consist of sandy silt over clay. Perched seasonal groundwater has been encountered at 3.6 to 4.2 feet bgs (Battelle Columbus Division, 1988). Other sources claim soils at the site consist of sandy clay loam and clay loam overlying clay at 44 inches bgs (SAIC, 1991).

### **2.3.3 Site Contaminants**

According to historical information, the Bulk POL Storage Area ASTs have contained JP-4, diesel fuel, and MOGAS. The USTs located to the south of the ASTs contained AVGAS. The two releases reported in 1980 consisted of JP-4. Total petroleum hydrocarbons (TPH) were detected at a concentration of 2,500 mg/kg in one subsurface soil sample collected immediately north of the tanks containing JP-4 (SAIC, 1991). More volatile hydrocarbons may be present from contamination related to unreported releases of AVGAS from the USTs at the site.

## **3.0 PILOT TEST ACTIVITIES**

The purpose of this section is to describe the pilot test activities proposed for Pumphouse 2, Pumphouse 3, and the Bulk POL Storage Area. The locations and

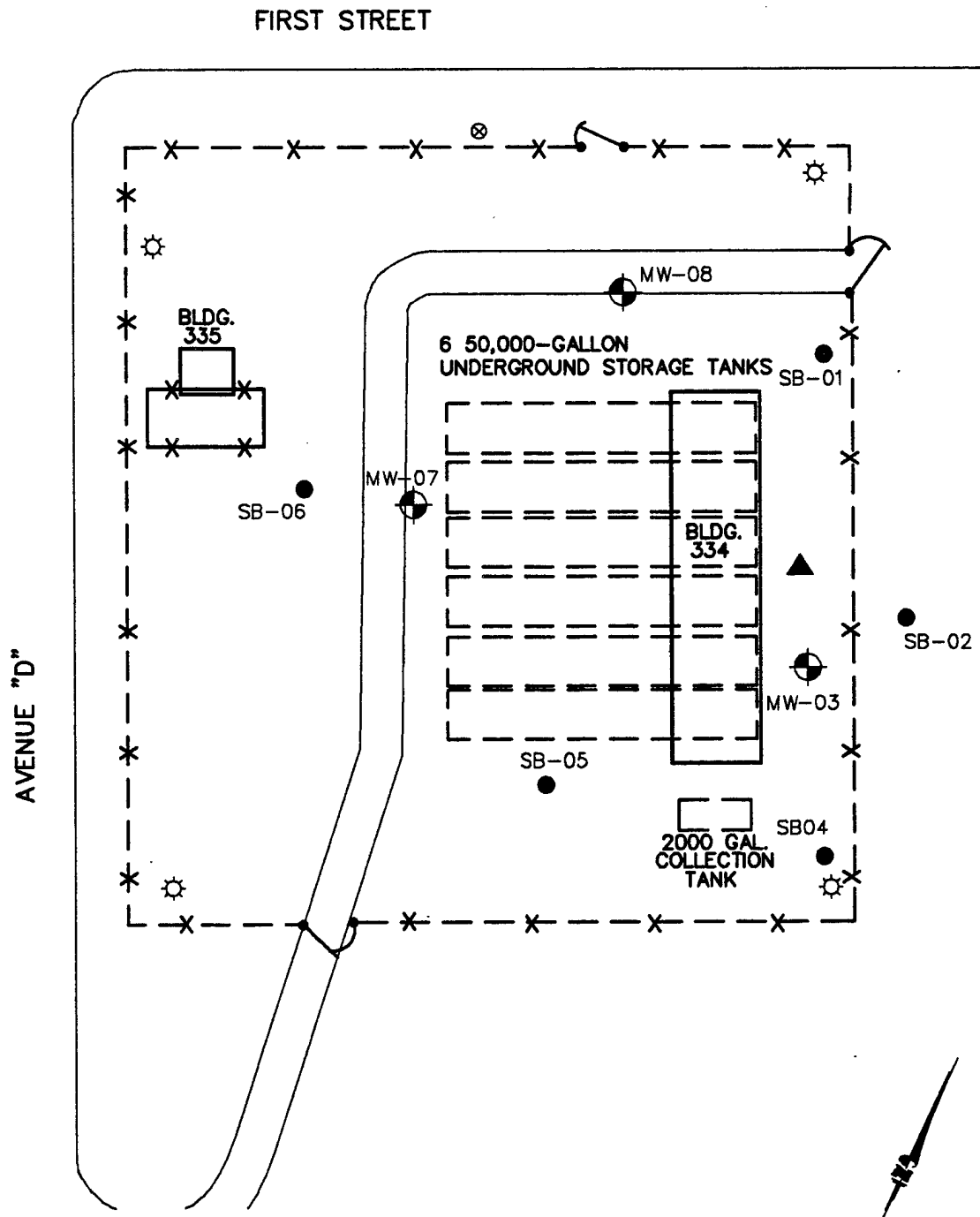

NOT TO SCALE

**LEGEND**

- ▲ VENT WELL
- MW-03 MONITORING WELL
- SB-07 SOIL BORING
- ☼ LIGHT POLE
- ⊗ POWER POLE
- X- -X- CHAIN LINK FENCE

NOTE: ALL WELL AND SOIL BORING LOCATIONS ARE APPROXIMATE.

**FIGURE 2.3**

**PS-3, PUMPHOUSE 3  
VENT WELL, SOIL BORING,  
AND MONITORING WELL  
LOCATIONS**

Malmstrom AFB, Montana

**ENGINEERING-SCIENCE, INC.**

Denver, Colorado

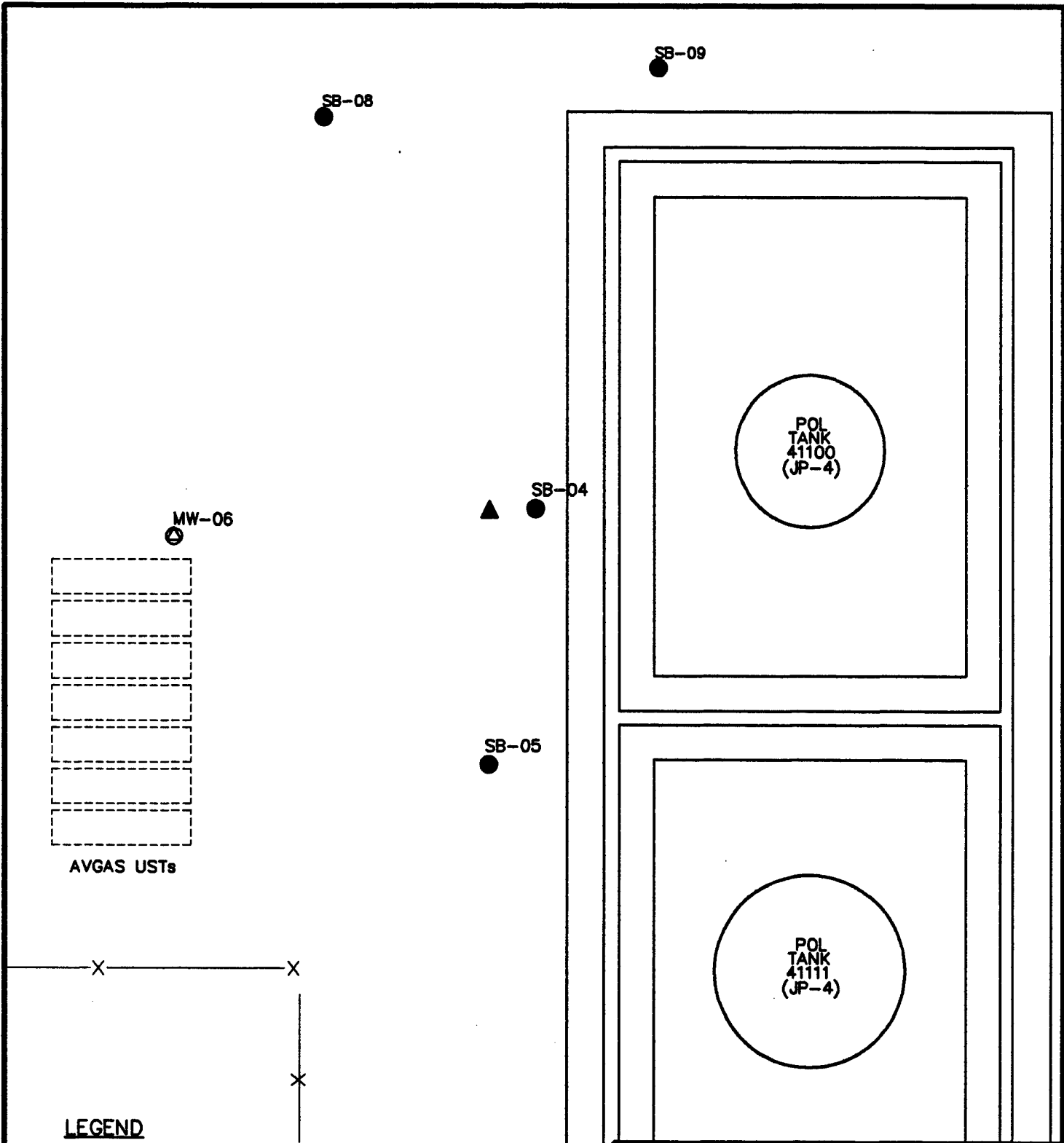

**LEGEND**

- ▲ VENT WELL
- SB-05 SOIL BORING
- MW-06 MONITORING WELL
- X-X- FENCE

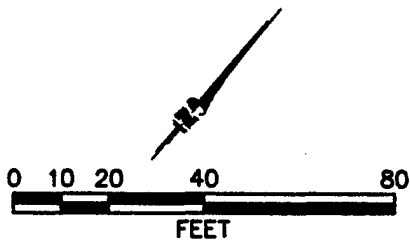

NOTE:  
LOCATIONS OF ALL WELLS AND SOIL BORINGS ARE APPROXIMATE.

**FIGURE 2.4**

**PS-4, BULK POL STORAGE AREA  
VENT WELL, SOIL BORING, AND  
MONITORING WELL LOCATIONS**

Malmstrom AFB, Montana

**ENGINEERING-SCIENCE, INC.**

Denver, Colorado

construction details for the MPs are discussed. Criteria for locating a suitable background well are outlined. Soil and soil gas sampling procedures and the blower configuration that will be used to inject air (oxygen) into contaminated soils are also discussed in this section. Finally, a brief description of the pilot test procedures is provided.

Bioventing technology is intended to remediate contamination only in the unsaturated zone. Therefore, pilot test activities will be confined mainly to unsaturated soils. Central VWs may be completed to approximately 2 or 3 feet below the current perched groundwater surface to provide oxygen to the deepest levels of the unsaturated zone, in case the groundwater level recedes due to natural fluctuation. No dewatering will take place during the pilot tests.

Existing monitoring wells will not be used as primary air injection wells or vapor MPs. However, if any monitoring wells have a portion of their screened interval above the water table, they may be used to measure the composition of background soil gas.

### **3.1 Vent Wells**

A general description of criteria for siting a central VW and MPs are included in the protocol document (Hinchee et al., 1992). One VW was installed at each of the three sites during site investigation activities performed by HDR, Inc. (1993) of Omaha, Nebraska. Wells were installed in the area of highest contamination at each site as determined by field screening of soil samples. Soils in these areas are expected to be contaminated with TPH, and to be oxygen-depleted (< 2%). Biological activity should be stimulated by oxygen-rich air added during pilot test operations.

Figure 3.1 illustrates a typical VW construction detail. VWs are constructed of 4-inch-diameter, Schedule 40 polyvinyl chloride (PVC), with a 5-foot interval of 0.04-inch slotted screen set at 5 to 10 feet bgs. The depth and length of the screen for each VW were determined in the field based on groundwater levels and soil contamination data. Flush-threaded PVC casing and screen with no organic solvents or glues were used. The filter pack consists of clean, well-rounded silica sand with a 6-9 grain size placed in the annular space to 1 foot above the screened interval. A layer of bentonite, hydrated with potable water, was placed directly over the filter pack. Thickness of the seal was determined by field conditions and is, in any case, no less than 3 feet. The boreholes have been completed to the ground surface with a bentonite/cement grout, and 12-inch flush-mount well boxes have been installed. A complete seal is critical to prevent injected air from short-circuiting to the surface during the bioventing test.

The potential radius of venting influence around the central VWs at each site is expected to be 25 to 35 feet. Three MPs (MPA, MPB, and MPC) will be located within a 35-foot radius of the central VW.

### **3.2 Monitoring Points**

A typical multi-depth MP installation is shown in Figure 3.2. At each site, MPs will be placed within a 35-foot radius of the central VW. Depths of the two screened intervals at each point will be determined in the field based on soil type, contamination, ground-water levels, and the depths of the screened intervals in the VWs. Soil gas oxygen and carbon dioxide concentrations will be initially monitored at all screened

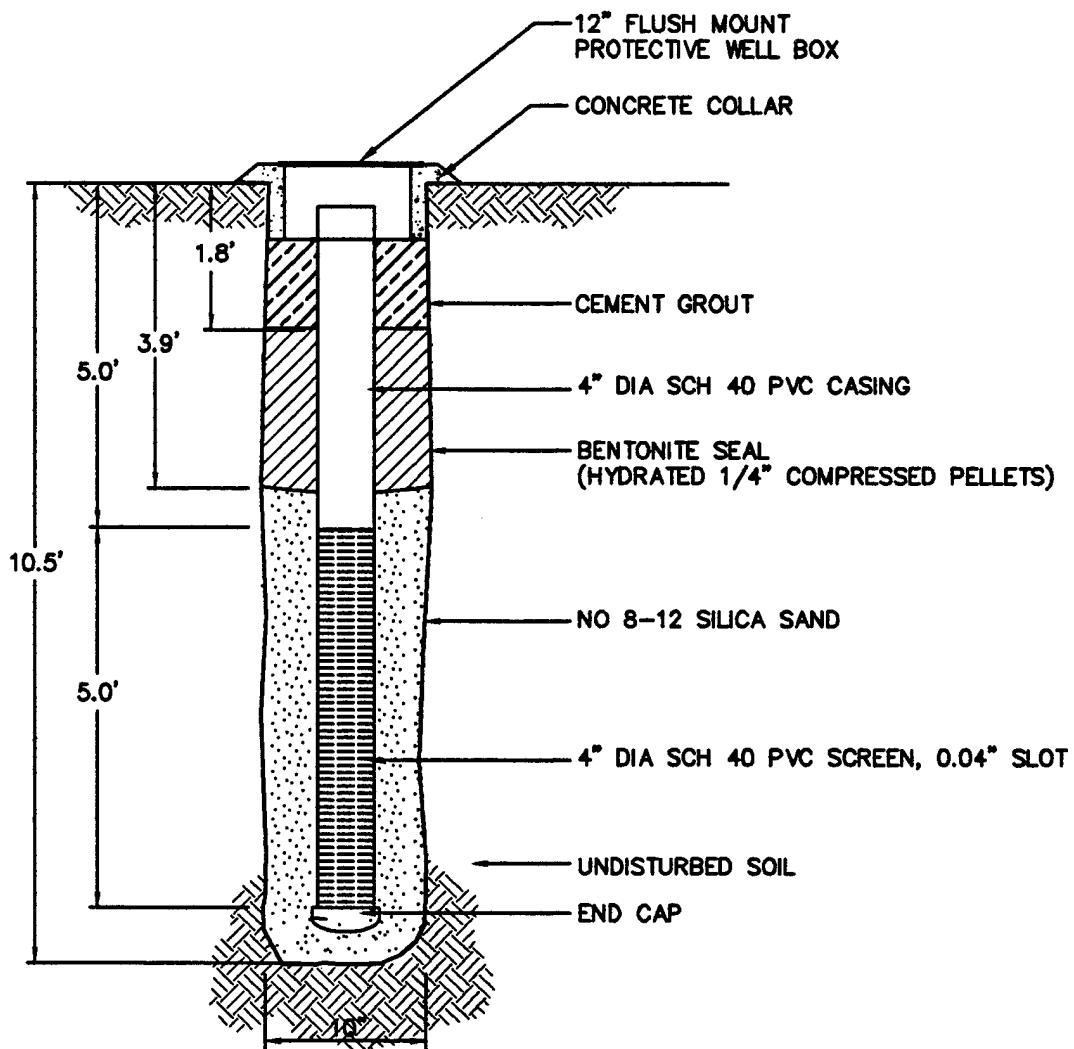

NOT TO SCALE

**FIGURE 3.1**  
**TYPICAL INJECTION VENT WELL**  
**CONSTRUCTION DETAIL**

Malmstrom AFB, Montana

**ENGINEERING-SCIENCE, INC.**

Denver, Colorado

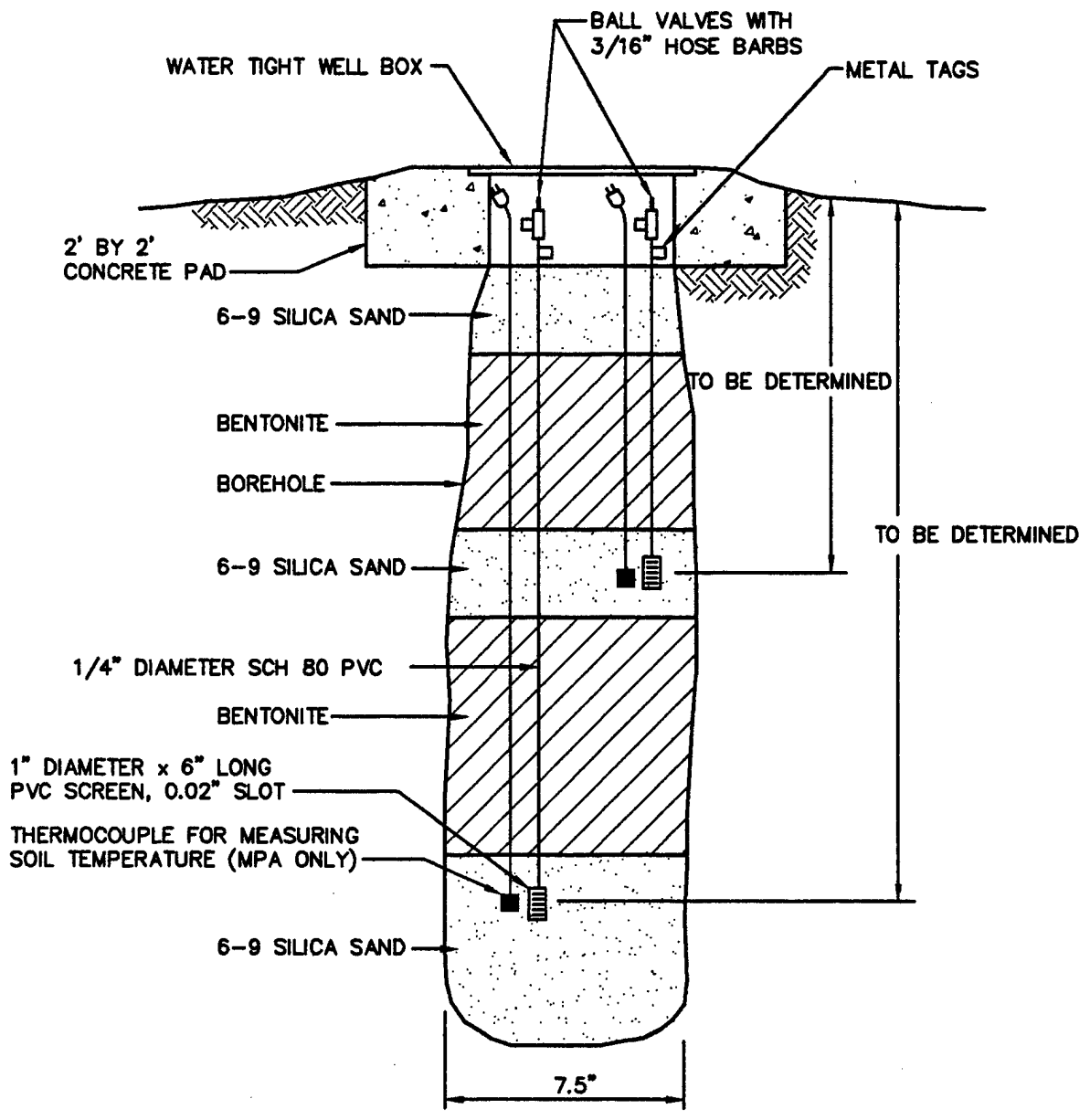

NOT TO SCALE

**FIGURE 3.2**

**TYPICAL MONITORING POINT  
CONSTRUCTION DETAIL**

Malmstrom AFB, Montana

**ENGINEERING-SCIENCE, INC.**

Denver, Colorado

intervals at all three sites. Multi-depth monitoring will confirm that the entire soil profile is receiving oxygen and will be used to measure fuel biodegradation rates. Due to the current high water table conditions at all sites, ES may place deep MPs below the water table with the expectation that they will be useful when the groundwater table drops. Two thermocouples will be installed at one MP location at each site to measure the soil temperature. One thermocouple will be placed at the shallowest screened interval and the other at the deepest screened interval. The annular spaces between the screened MP intervals will be sealed with bentonite to isolate the monitoring intervals. As with the central VW, the bentonite will be hydrated with potable water. Additional details on VW and MP construction are presented in Section 4 of the protocol document (Hinchee et al., 1992).

### **3.3 Background Well**

The construction of an additional MP may be required to measure background levels of oxygen and carbon dioxide, and to determine if natural carbon sources are contributing to oxygen uptake during the *in situ* respiration test described in Section 3.5. This background well would be installed in an area of uncontaminated soil representative of the stratigraphic formations found at the sites at the Base. The background well will be similar in construction to the MPs (Figure 3.2), and will be screened at two depths. ES will require some assistance from Base personnel in locating an appropriate position for the proposed background well.

An existing groundwater monitoring well located in an area with no fuel contamination and a 110-volt power supply within 100 feet may be suitable for use as a background well. This well must have a portion of the screened interval above the water table if the well is to be used as a background well. Additional information regarding background wells may be found in Section 4.3 of the protocol document (Hinchee et al., 1992).

### **3.4 Handling of Drill Cuttings**

Drill cuttings from MP borings will be collected in U.S. Department of Transportation (DOT)-approved containers. The containers will be labeled and placed in the Base hazardous materials storage area. These drill cuttings will become the responsibility of the Base, and will be analyzed, handled, and disposed of or treated on-Base in accordance with the current procedures for ongoing remedial investigations. This project is expected to generate approximately six 55-gallon drums of cuttings.

### **3.5 *In Situ* Respiration Tests**

The objective of the *in situ* respiration tests is to determine the rate at which soil bacteria degrade petroleum hydrocarbons. Respiration tests will be performed at every MP where bacterial biodegradation of hydrocarbons is indicated by low initial oxygen levels and elevated carbon dioxide concentrations in the soil gas. Using 1-standard-cubic-foot-per-minute (scfm) pumps, air will be injected into each MP depth interval containing low levels (<2%) of oxygen. A 20-hour air injection period will be used to oxygenate local contaminated soils. At the end of the 20-hour air injection period, the air supply will be cut off, and oxygen and carbon dioxide levels will be monitored for the following 48 to 72 hours. The decline in oxygen and increase in carbon dioxide

concentrations over time will be used to estimate rates of bacterial degradation of fuel residuals. A helium tracer will also be injected into each MP with low initial oxygen levels and monitored for the duration of the respiration test to determine the effectiveness of the bentonite seals between screened intervals. Additional details on the *in situ* respiration test procedures are provided in Section 5.7 of the protocol document (Hinchee et al., 1992).

### **3.6 Air Permeability Tests**

The objective of the air permeability tests is to determine the extent of the subsurface that can be oxygenated using the VW. Air will be injected into the 4-inch-diameter VWs using a 3-horsepower positive-displacement blower. The blower is capable of injecting air over a wide range of flow rates and pressures. Figure 3.3 is a schematic of a typical air injection system used for pilot testing. The maximum power requirement anticipated for this pilot test is 230-volt, single-phase, 30-amp service. Additional details on power supply requirements are described in Section 8.0, Base Support Requirements.

During the permeability test, pressure response will be measured at each MP with differential pressure gauges to determine the region influenced by the injection unit. Oxygen will also be monitored in the MPs to ascertain whether oxygen levels in the soil increase as the result of air injection. One air permeability test lasting 4 to 8 hours will be performed at each site.

### **3.7 Blower System**

Extended, 1-year bioventing systems will also be installed at the Base. A schematic of a typical air injection system used for pilot testing is shown in Figure 3.3. At each site, a licensed electrical subcontractor to ES will provide a 230-volt, single-phase, 20-amp breaker box; one 230-volt receptacle; and two 110-volt receptacles. The subcontracted electrician will also be requested to assist in wiring the blowers to line power. The blowers will be housed in small, prefabricated sheds to provide protection from the weather. Whenever possible, blowers will be located outside of fueling areas so that nonexplosion-proof wiring can be used.

The systems will be in operation for 1 year. Every 6 months, ES personnel will conduct *in situ* respiration tests to monitor the long-term performance of this bioventing system. Weekly system checks will be performed by Base personnel. Detailed blower system information and a maintenance schedule will be included in the operation and maintenance (O&M) manual provided to the Base. More detailed information regarding the test procedures can be found in the protocol document.

### **3.8 Soil and Soil Gas Sampling**

#### **3.8.1 Soil Samples**

Subsurface soil will be collected from MP borings. One sample from the most contaminated interval of each bore hole will be sent for analysis. The most contaminated interval will be determined by field headspace screening of soil samples. Three samples from each site will be submitted for laboratory analysis. Soil samples will be

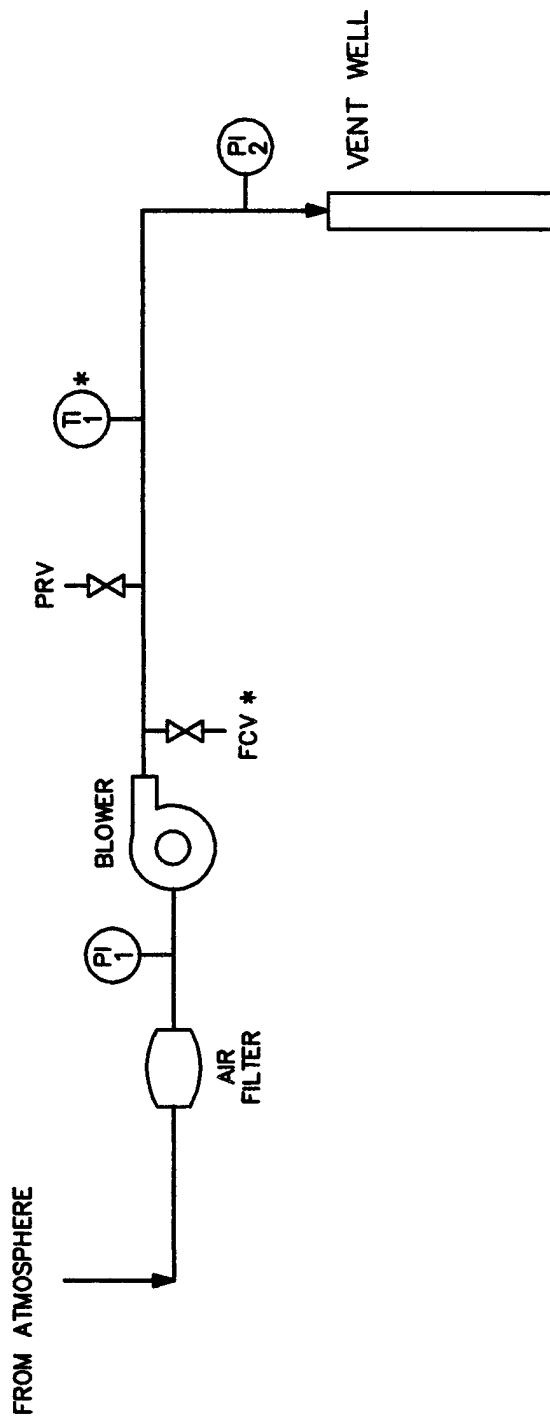

**LEGEND**

- PI 1 PRESSURE INDICATOR
- TI 1 TEMPERATURE INDICATOR
- FCV FLOW CONTROL VALVE
- PRV PRESSURE RELIEF VALVE
- \* OPTIONAL

**FIGURE 3.3**

**TYPICAL BLOWER SYSTEM  
INSTRUMENTATION DIAGRAM  
FOR AIR INJECTION**

Malmstrom AFB, Montana  
**ENGINEERING-SCIENCE, INC.**  
Denver, Colorado

collected from a 2-inch split-spoon sampler equipped with four brass or stainless-steel ring liners.

Soil samples will be analyzed for total recoverable petroleum hydrocarbons (TRPH); benzene, toluene, ethylbenzene and xylene (BTEX); soil moisture; pH; particle sizing; alkalinity; total iron; and nutrients.

Samples for TRPH and BTEX analysis will be collected using a 2-inch-diameter split-spoon sampler containing brass tube liners. Soil samples collected in the brass tubes for TRPH and BTEX analyses will be immediately trimmed, and the ends will be sealed with aluminum foil or Teflon® fabric held in place by plastic caps. Soil samples collected for physical parameter analyses will be placed in glass sample jars or other appropriate sample containers. Soil samples will be labeled following the nomenclature specified in the protocol document (Section 5), wrapped in plastic, and placed in a cooler maintained at a temperature of 4 degrees centigrade (°C) for shipment. A chain-of-custody (COC) form will be filled out, and the cooler will be shipped to the Pace, Inc. laboratory in Novato, California, for analysis. This laboratory has been audited by the Air Force and meets all quality assurance/quality control (QA/QC) and certification requirements of the State of California.

### **3.8.2 Soil Gas Samples**

A total hydrocarbon vapor analyzer will be used during augering to screen split-spoon soil samples for intervals of significant fuel contamination. Initial soil gas samples will be collected in 1-liter SUMMA® canisters in accordance with the *Bioventing Field Sampling Plan* (Engineering-Science, Inc., 1992) from the VWs, and from the MPs closest to and farthest from the VWs. Additionally, these soil gas samples will be used to predict potential air emissions, to determine the reduction in BTEX and total volatile hydrocarbons (TVH) during the 1-year test, and to detect any migration of these vapors from the source area.

Soil gas sample canisters will be placed in a small cooler and packed with foam pellets or other packing material to prevent excessive movement during shipment. Samples will not be sent on ice to prevent condensation of hydrocarbons. A COC form will be filled out, and the cooler will be shipped to the Air Toxics, Ltd. laboratory in Folsom, California for analysis. Soil gas samples will be analyzed for TPH and BTEX by EPA Method T0-3.

## **4.0 EXCEPTIONS TO PROTOCOL PROCEDURES**

The procedures that will be used to measure the air permeability of the soil and *in situ* respiration rates are described in Sections 4 and 5 of the protocol document (Hinchee et al., 1992). No exceptions to the protocol procedures are anticipated. If high water table conditions prevent completion of all initial tests, the tests will be rescheduled during the 6-month respiration testing.

## **5.0 BASE SUPPORT REQUIREMENTS**

The following Base support is needed prior to the arrival of the drilling subcontractor and the ES pilot test team:

- Assistance in obtaining drilling and digging permits;
- Assistance in selecting a suitable location for the background well. The background well location should be in an area with no fuel contamination and with similar stratigraphy to that of the three sites at the Base. Preferably, a 110-volt power receptacle should be available within 200 feet of the background well location; and
- Provision of any paperwork required to obtain gate passes and security badges for approximately two ES employees and an electrical subcontractor.

During the initial testing, the following Base support is needed:

- A decontamination pad where augers and sampling equipment can be cleaned between borings,
- Twelve square feet of desk space and a telephone in a building located as close to the sites as practicable, and
- The use of a facsimile machine for transmitting 15 to 20 pages of test results.

During the 1-year extended pilot test, Base personnel will be required to perform the following activities:

- Check the blower systems once per week to ensure that they are operating, and record the operating parameters (pressure, vacuum, and temperature). ES will provide a brief training session on these procedures and an O&M manual;
- If a blower stops working, notify Mr. Brian Blicher, Mr. Rusty Frishmuth, or Mr. Doug Downey, ES-Denver, at (303) 831-8100, or Mr. Sam Taffinder, Air Force Center for Environmental Excellence (AFCEE), at (512) 536-4366; and
- Arrange site access for an ES technician to conduct *in situ* respiration tests approximately 6 months and 1 year after the initial pilot test.

## 6.0 PROJECT SCHEDULE

The following schedule is contingent upon timely approval of this pilot test work plan.

<u>Event</u>	<u>Date</u>
Draft Pilot Test Work Plan to AFCEE/Malmstrom AFB	23 September 1993
Begin Initial Pilot Tests	28 September 1993
Complete Initial Pilot Tests	15 October 1993
Interim Results Report	3 December 1993
Second Respiration Tests	April 1994
Final Respiration Tests	October 1994

## 7.0 POINTS OF CONTACT

Mr. James Hodges and  
Mr. Dan Duff  
43 CES/CEV  
39-78th Street North  
Malmstrom AFB, MT 59402-7536  
(406) 731-7126

Mr. Sam Taffinder  
AFCEE/EST Building 624W  
Brooks AFB, TX 78235-5000  
(512) 536-4366

Mr. Russell Frishmuth and  
Mr. Doug Downey  
Engineering-Science, Inc.  
1700 Broadway, Suite 900  
Denver, CO. 80290  
(303) 831-8100  
Fax (303) 831-8208

## 8.0 REFERENCES

- Battelle Columbus Division. 1988. *Installation Restoration Program Phase II - Confirmation/Quantification Stage 1, Malmstrom Air Force Base, Great Falls Montana*. November.
- Engineering-Science, Inc. (ES) 1992. *Field Sampling Plan for AFCEE Bioventing*. January.
- Hinchee, R.E., S.K. Ong, R.N. Miller, D.C. Downey, and R. Frandt. 1992. *Test Plan and Technical Protocol for a Field Treatability Test for Bioventing*. January.
- HDR Engineering, Inc. 1993. Personal Communication, facsimile transmittal of as-built drawings. September 14.
- JRB Associates. 1985. *Installation Restoration Program Phase I - Records Search, 341st Strategic Missile Wing, Malmstrom AFB, Montana*. January.
- Science Applications International Corporation (SAIC). 1991. *Installation Restoration Program (IRP) Stage 2 Remedial Investigation/Feasibility Study, Malmstrom Air Force Base, Montana*. July.
- Woodward-Clyde Consultants. 1993. *RCRA Facility Investigation, Malmstrom Air Force Base, Great Falls, Montana*. January.

PART II  
DRAFT INTERIM PILOT TEST RESULTS REPORT FOR  
PS-3 (PUMPHOUSES 2 AND 3)  
AND  
PS-4 (BULK POL STORAGE AREA)  
MALMSTROM AFB, MONTANA

Prepared for:

Air Force Center for Environmental Excellence

Brooks AFB, Texas

and

43 CES/CEVR

Malmstrom AFB, Montana

Prepared by:

Engineering-Science, Inc.  
1700 Broadway, Suite 900  
Denver, Colorado 80290

December 1993

## CONTENTS

### PART II - DRAFT INTERIM PILOT TEST RESULTS REPORT FOR PS-3 (PUMPHOUSES 2 AND 3) AND PS-4 (BULK POL STORAGE AREA) MALMSTROM AFB, MONTANA

	<u>Page</u>
1.0 Pilot Test Design and Construction .....	II-1
1.1 PS-3, Pumphouse 2 .....	II-2
1.1.1 Air Injection Vent Well .....	II-2
1.1.2 Monitoring Points .....	II-2
1.1.3 Blower Unit .....	II-2
1.2 PS-4, Bulk POL Storage Area .....	II-8
1.2.1 Air Injection Vent Well .....	II-8
1.2.2 Monitoring Points .....	II-8
1.2.3 Blower Unit .....	II-8
2.0 Pilot Test Soil and Soil Gas Sampling Results .....	II-14
2.1 PS-3, Pumphouse 2 .....	II-14
2.1.1 Sampling Results .....	II-14
2.1.2 Exceptions to Test Protocol Document Procedures .....	II-14
2.1.3 Field QA/QC Results .....	II-14
2.2 PS-4, Bulk POL Storage Area .....	II-16
2.2.1 Sampling Results .....	II-16
2.2.2 Exceptions to Test Protocol Document Procedures .....	II-19
3.0 Pilot Test Results .....	II-19
3.1 PS-3, Pumphouse 2 .....	II-19
3.1.1 Initial Soil Gas Chemistry .....	II-19
3.1.2 Air Permeability .....	II-19
3.1.3 Oxygen Influence .....	II-19
3.1.4 <i>In Situ</i> Respiration Rates .....	II-23
3.1.5 Potential Air Emissions .....	II-23
3.2 PS-4, Bulk POL Storage Area .....	II-23
3.2.1 Initial Soil Gas Chemistry .....	II-23
3.2.2 Air Permeability .....	II-23
3.2.3 Oxygen Influence .....	II-29
3.2.4 <i>In Situ</i> Respiration Rates .....	II-29
3.2.5 Potential Air Emissions .....	II-36
4.0 Recommendations .....	II-36
4.1 PS-3, Pumphouse 2 .....	II-36
4.2 PS-4, Bulk POL Storage Area .....	II-36
5.0 References .....	II-37

Appendix A Geologic Boring Logs, Chain-of-Custody Forms, Test Data, and Calculations

Appendix B Operation and Maintenance Checklist

### TABLES

<u>No.</u>	<u>Title</u>	<u>Page</u>
2.1	Soil and Soil Gas Laboratory Analytical Results, PS-3, Pumphouse 2.....	II-15
2.2	Field and Laboratory QA/QC Analytical Results, PS-3, Pumphouse 2.....	II-17
2.3	Soil and Soil Gas Laboratory Analytical Results, PS-4, Bulk POL Storage Area .....	II-18
3.1	Initial Soil Gas Chemistry, PS-3, Pumphouse 2.....	II-20
3.2	Maximum Pressure Response, Air Permeability Test, PS-3, Pumphouse 2.....	II-21
3.3	Influence of Air Injection at Vent Well on Monitoring Point Oxygen Levels, PS-3, Pumphouse 2.....	II-22
3.4	Oxygen Utilization Rates, PS-3, Pumphouse 2.....	II-27
3.5	Initial Soil Gas Chemistry, PS-4, Bulk POL Storage Area .....	II-28
3.6	Maximum Pressure Response, Air Permeability Test, PS-4, Bulk POL Storage Area .....	II-30
3.7	Influence of Air Injection at Vent Well on Monitoring Point Oxygen Levels, PS-4, Bulk POL Storage Area .....	II-31
3.8	Oxygen Utilization Rates, PS-4, Bulk POL Storage Area .....	II-35

### FIGURES

<u>No.</u>	<u>Title</u>	<u>Page</u>
1.1	As-Built Vent Wells, Monitoring Point, and Blower Locations, PS-3, Pumphouse 2.....	II-3
1.2	Hydrogeologic Cross Section, PS-3, Pumphouse 2.....	II-4
1.3	As-Built Injection Vent Well Construction Detail, PS-3, Pumphouse 2.....	II-5
1.4	As-Built Monitoring Point Construction Detail, PS-3, Pumphouse 2.....	II-6
1.5	As-Built Extended Pilot Test Blower System for Air Injection, PS-3, Pumphouse 2.....	II-7
1.6	As-Built Vent Well, Monitoring Point, and Blower Locations, PS-4, Bulk POL Storage Area .....	II-9
1.7	Hydrogeologic Cross Section, PS-4, Bulk POL Storage Area .....	II-10
1.8	As-Built Injection Vent Well Construction Detail, PS-4, Bulk POL Storage Area .....	II-11
1.9	As-Built Monitoring Point Construction Detail, PS-4, Bulk POL Storage Area .....	II-12
1.10	As-Built Extended Pilot Test Blower System for Air Injection, PS-4, Bulk POL Storage Area .....	II-13
3.1	Respiration Test Results: Monitoring Point MPA-4, PS-3, Pumphouse 2.....	II-24
3.2	Respiration Test Results: Monitoring Point MPB-4, PS-3, Pumphouse 2.....	II-25

FIGURES (Continued)

<u>No.</u>	<u>Title</u>	<u>Page</u>
3.3	Respiration Test Results: Monitoring Point MPC-4, PS-3, Pumphouse 2.....	II-26
3.4	Respiration Test Results: Monitoring Point MPA-3.5, PS-4, Bulk POL Storage Area .....	II-32
3.6	Respiration Test Results: Monitoring Point MPB-3.5, PS-4, Bulk POL Storage Area .....	II-33
3.7	Respiration Test Results: Monitoring Point MPC-3.5, PS-4, Bulk POL Storage Area .....	II-34

**PART II**  
**DRAFT**  
**INTERIM PILOT TEST RESULTS REPORT**  
**FOR PS-3 (PUMPHOUSES 2 AND 3)**  
**AND PS-4 (BULK POL STORAGE AREA)**  
**MALMSTROM AFB, MONTANA**

Initial bioventing pilot tests for *in situ* treatment of fuel-contaminated soils at PS-3 (Pumphouses 2 and 3) and PS-4 (Bulk POL Storage Area) at Malmstrom Air Force Base (AFB) (the Base), Montana were completed by Engineering-Science, Inc. (ES) during the period from September 28 through October 15, 1993. The three primary objectives of the pilot tests are:

- To assess the potential for supplying oxygen throughout the contaminated soil interval;
- To determine the rate at which indigenous microorganisms will degrade fuel when supplied with oxygen-rich soil gas, and
- To evaluate the potential for sustaining these rates of biodegradation until fuel contamination is remediated to concentrations below regulatory standards.

The purpose of this report is to describe the results of the initial pilot tests at PS-3 and PS-4, and to make specific recommendations for extended testing to determine the long-term impact of bioventing on site contaminants. Descriptions of the history, geology, and contamination at Pumphouses 2 and 3 and the Bulk POL Storage Area are contained in Part I, the Bioventing Pilot Test Work Plan.

The groundwater surface at Pumphouse 3 was 2.9 feet below ground surface (bgs) when measured on September 28, 1993. This shallow level prevented the installation of a bioventing air injection system, and the ES engineers therefore determined that the site should be abandoned. No further action was taken at the site.

### **1.0 PILOT TEST DESIGN AND CONSTRUCTION**

Installation of three vapor monitoring points (MPs) at Pumphouse 2 took place September 30 through October 2, 1993. Installation of three MPs at the Bulk POL Storage Area took place October 10 through 11, 1993. Drilling, MP installation, and soil sampling was conducted by Mr. Rusty Frishmuth, ES site manager, and Mr. David Teets, ES site technician. Electrical services for both sites were provided by Cascade Electric, Inc. of Great Falls, Montana. The vent wells (VWs) at each site were installed in August 1993 by

HDR Engineering Inc. of Omaha, Nebraska. The following sections describe the final design and installation of the bioventing systems at each site.

### **1.1 PS-3, Pumphouse 2**

Three MPs and a blower unit were installed at Pumphouse 2. Locations of the VW and MPs completed at the site are shown in Figure 1.1. The hydrogeologic cross-section of the site is shown in Figure 1.2. Boring logs for the MPs and VW are included in Appendix A. The background MP for this site, installed near the southeastern boundary of the Base, is screened at 4 feet bgs.

#### **1.1.1 Air Injection Vent Well**

The air injection VW, designated as Biovent Pumphouse #2, was installed by HDR Engineering, Inc. following procedures described in the Air Force Center for Environmental Excellence (AFCEE) bioventing protocol document (Hinchee et al., 1992). Figure 1.3 shows construction details for the VW. The VW was installed in contaminated soils with the screened interval extending from 5 to 10 feet bgs. The groundwater surface was approximately 5.2 feet bgs prior to the pilot test. The VW was constructed using 4-inch-diameter, Schedule 40 polyvinyl chloride (PVC) casing, with 5 feet of 0.04-inch slotted PVC screen. The annular space between the well casing and borehole was filled with 8-12 grain-size silica sand from the bottom of the borehole to approximately 1 foot above the well screen. Two feet of granular bentonite was placed above the sand, hydrated in place, and overlaid with a concrete seal to the existing gravel surface (HDR Engineering Inc., 1993).

#### **1.1.2 Monitoring Points**

MP screens were installed at 4- and 6.5-foot depths. The three MPs (MPA, MPB, and MPC) at this site were constructed as shown in Figure 1.4. MPA, MPB, and MPC were installed 5, 15, and 25 feet from the VW, respectively. Each was constructed using 6-inch sections of 1-inch-diameter PVC well screen with 0.25-inch PVC riser pipes extending to the ground surface. At the top of each riser, a ball valve and a 3/16-inch hose barb were installed. The top of each MP was completed with a flush-mounted metal well protector set in concrete. Thermocouples were installed at the 4- and 6.5-foot depths at MPA to measure soil temperature variations.

#### **1.1.3 Blower Unit**

A 3-horsepower Roots® positive-displacement blower unit was used at Pumphouse 2 for the initial pilot test, and a 1-horsepower Gast® rotary-vane blower unit was installed at the site for the extended pilot test. The initial pilot test blower was energized by 208-volt, single-phase, 20-amp power from a temporary receptacle inside Building 246; the extended pilot test unit is hard-wired to a newly-installed breaker inside the blower enclosure. The 1-horsepower extended pilot test blower was configured to inject approximately 10 standard cubic feet per minute (scfm) for the extended pilot test. The configuration, instrumentation, and specifications for the extended pilot test unit are shown on Figure 1.5. Prior to departing from the site, ES engineers provided an operations and maintenance (O&M) briefing checklist and blower maintenance manual to Base personnel. A copy of the checklist is provided in Appendix B.

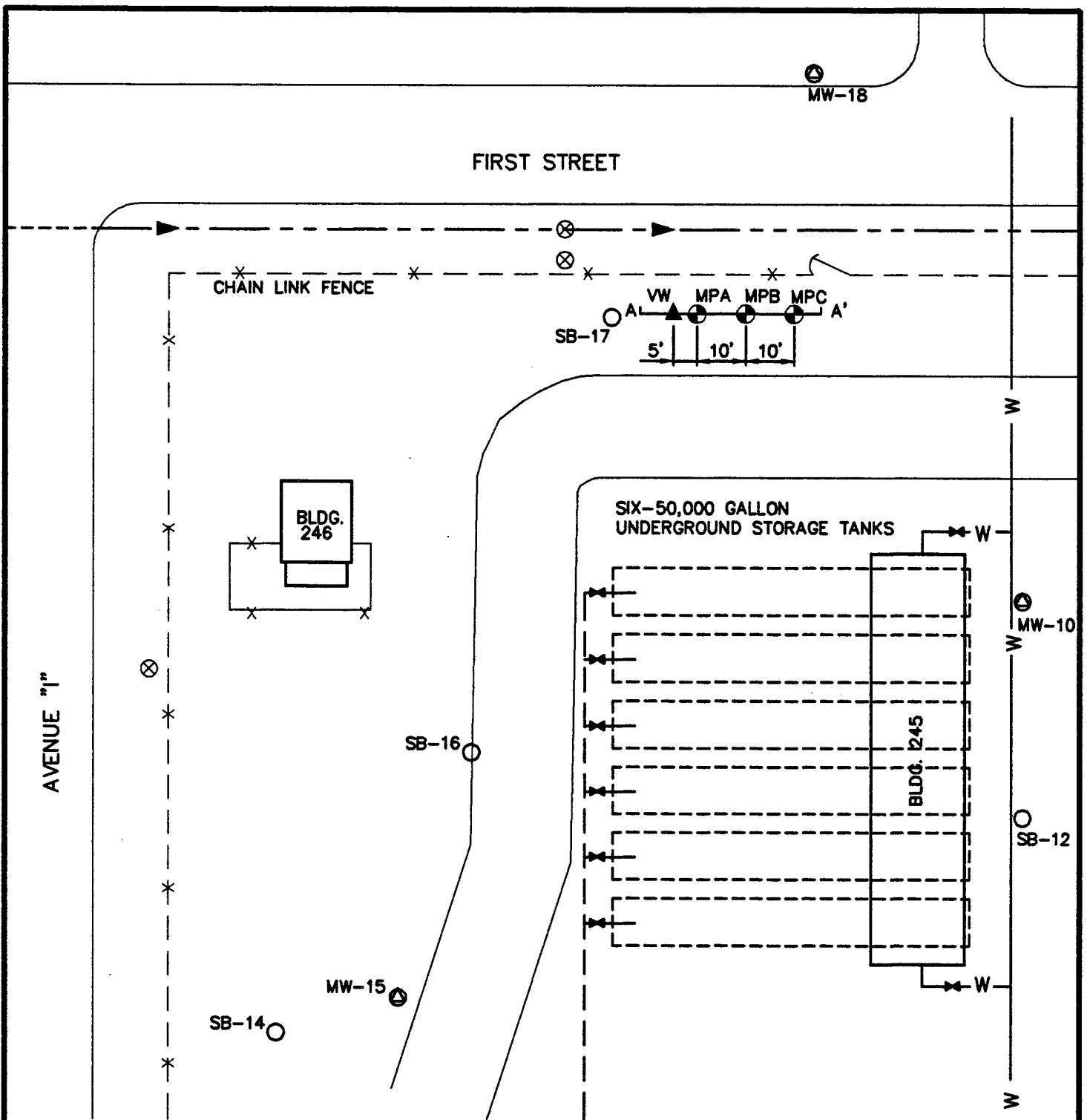

**LEGEND**

- ▲ VENT WELL
- SB-12 SOIL BORING
- ⊕ MW-15 MONITORING WELL
- ⊕ MPA MONITORING POINT
- ⊗ POWER POLE
- W — WATER LINE
- — — DRAINAGE DITCH
- - - FUEL PIPELINE
- A-A' PROFILE



**FIGURE 1.1**  
**AS-BUILT VENT WELL**  
**AND MONITORING POINT**  
**LOCATIONS**  
**PS-3, PUMPHOUSE 2**  
  
 Malmstrom AFB, Montana  

---

**ENGINEERING-SCIENCE, INC.**  
 Denver, Colorado

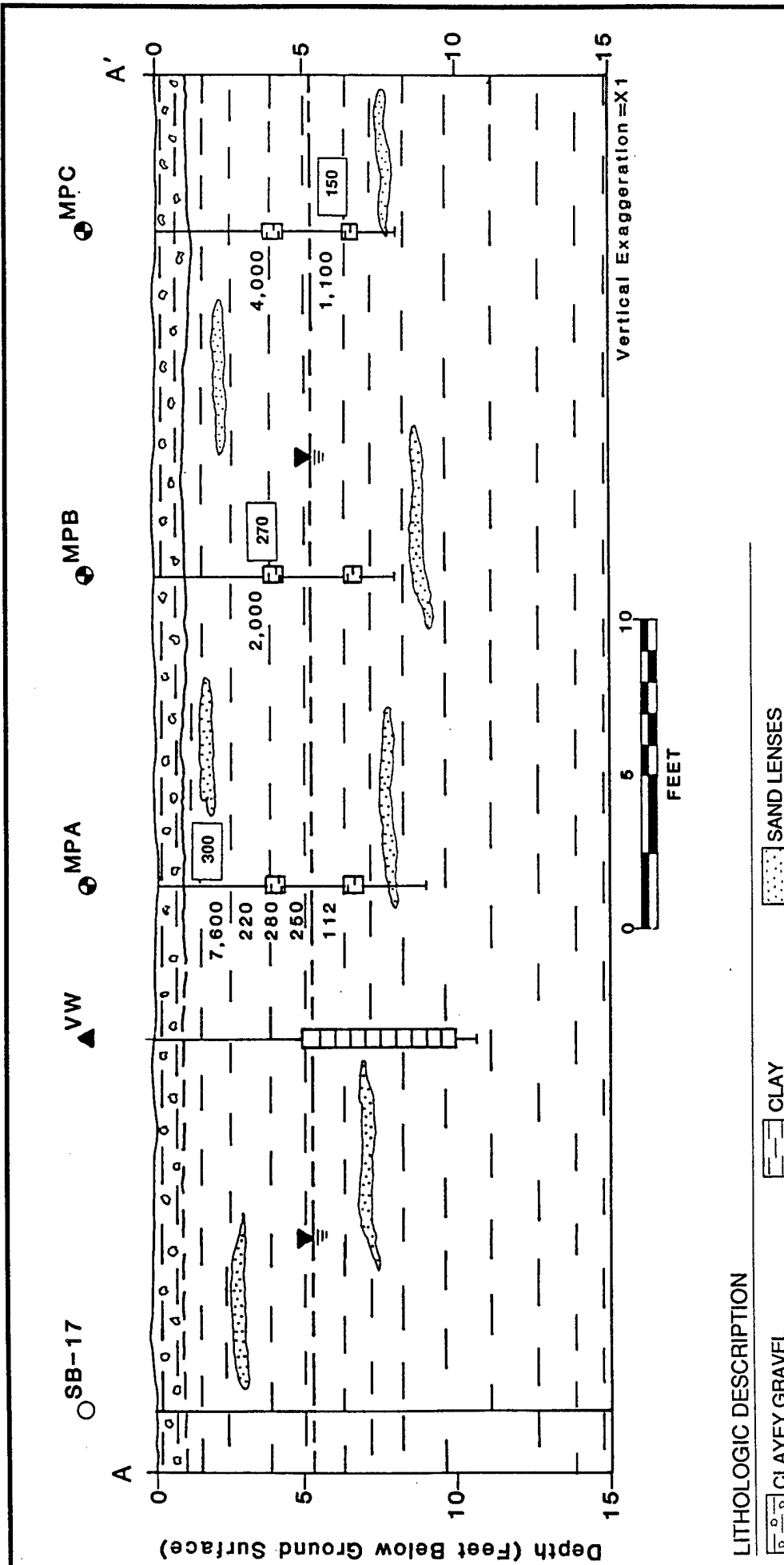

LITHOLOGIC DESCRIPTION

- CLAYEY GRAVEL
- CLAY
- SAND LENSES

LEGEND

- VENT WELL
- MONITORING POINT
- SOIL BORING
- FIELD SCREENING RESULTS FOR TOTAL VOLATILE HYDROCARBONS (ppmv)
- LABORATORY RESULTS FOR SOIL TOTAL PETROLEUM HYDROCARBONS (mg/kg)
- GROUNDWATER ELEVATION
- GEOLOGIC CONTACT, DASHED WHERE INFERRED
- MONITORING POINT SCREENED INTERVAL
- SCREENED WELL INTERVAL

FIGURE 1.2

**HYDROGEOLOGIC  
CROSS SECTION  
PS-3, PUMPHOUSE 2**

MALMSTROM AFB, MONTANA

**ENGINEERING-SCIENCE, INC.**

Denver, Colorado

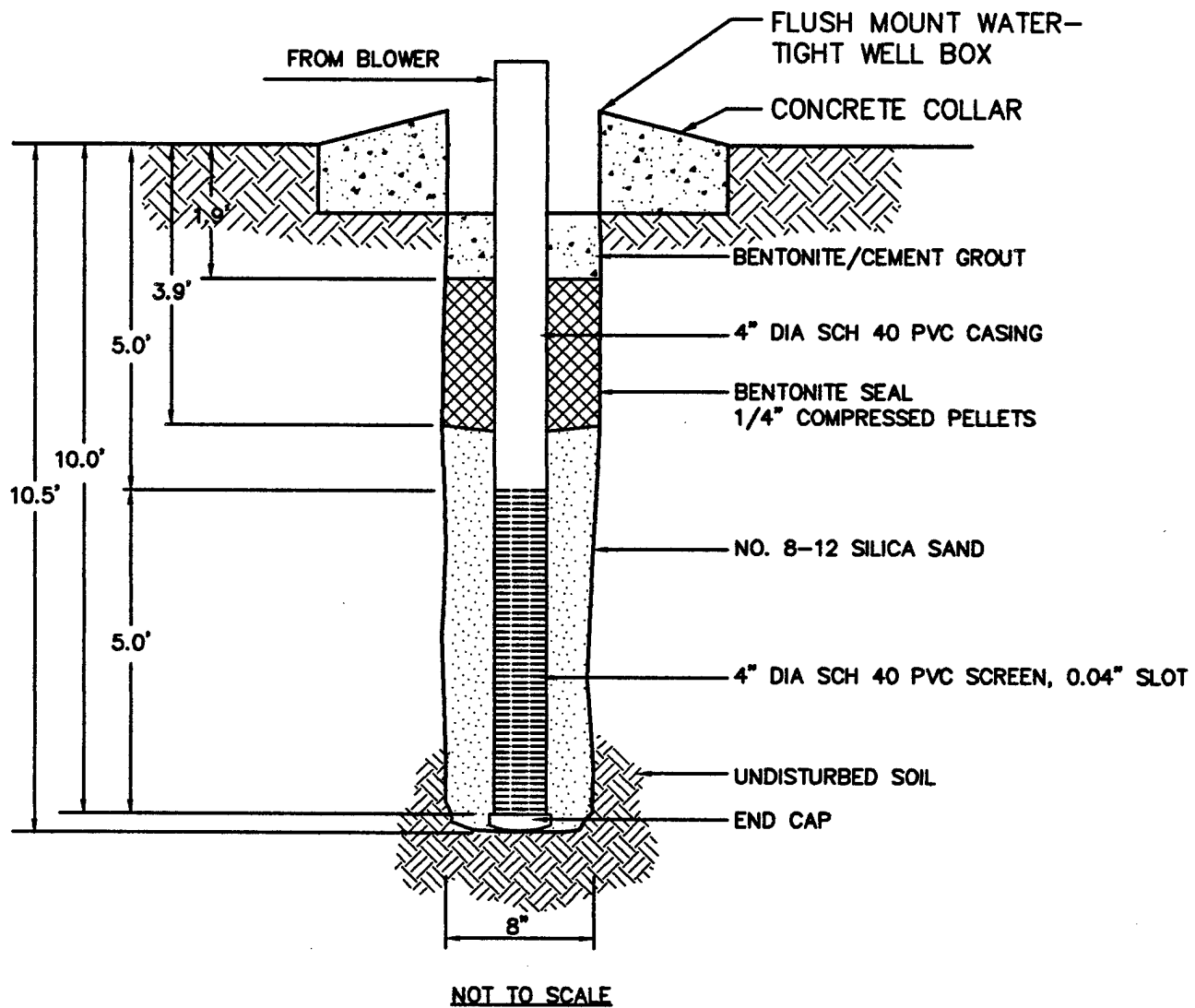
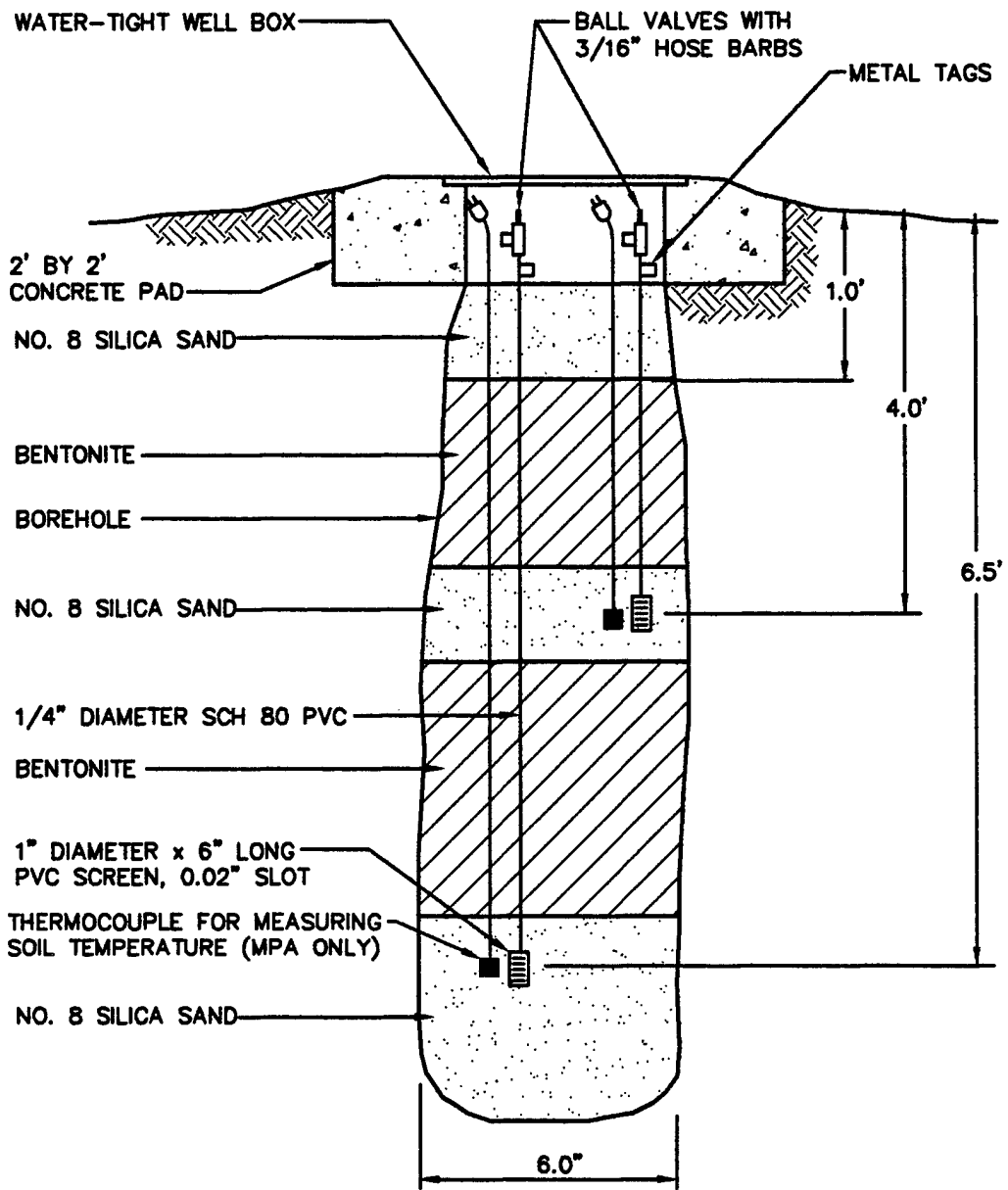

**FIGURE 1.3**  
**AS-BUILT INJECTION/VENT**  
**WELL CONSTRUCTION DETAIL**  
**PS-3, PUMPHOUSE 2**

MALMSTROM AFB, MONTANA

**ENGINEERING-SCIENCE, INC.**

Denver, Colorado



NOT TO SCALE

FIGURE 1.4

TYPICAL AS-BUILT  
MONITORING POINT  
CONSTRUCTION DETAIL  
PS-3, PUMPHOUSE 2

Malmstrom AFB, Montana

**ENGINEERING-SCIENCE, INC.**

Denver, Colorado

LEGEND

- ① INLET AIR FILTER - SOLBERG® F-18P-150
- ② VACUUM GAUGE (in H<sub>2</sub>O)
- ③ 1-HP BLOWER - GAST® R4110N-50
- ④ MANUAL PRESSURE RELIEF (BLEED) VALVE
- ⑤ AUTOMATIC PRESSURE RELIEF VALVE
- ⑥ PRESSURE GAUGE (in H<sub>2</sub>O)
- ⑦ TEMPERATURE GAUGE (°F)
- ⑧ BREAKER BOX - 230V/SINGLE PHASE/30 AMP

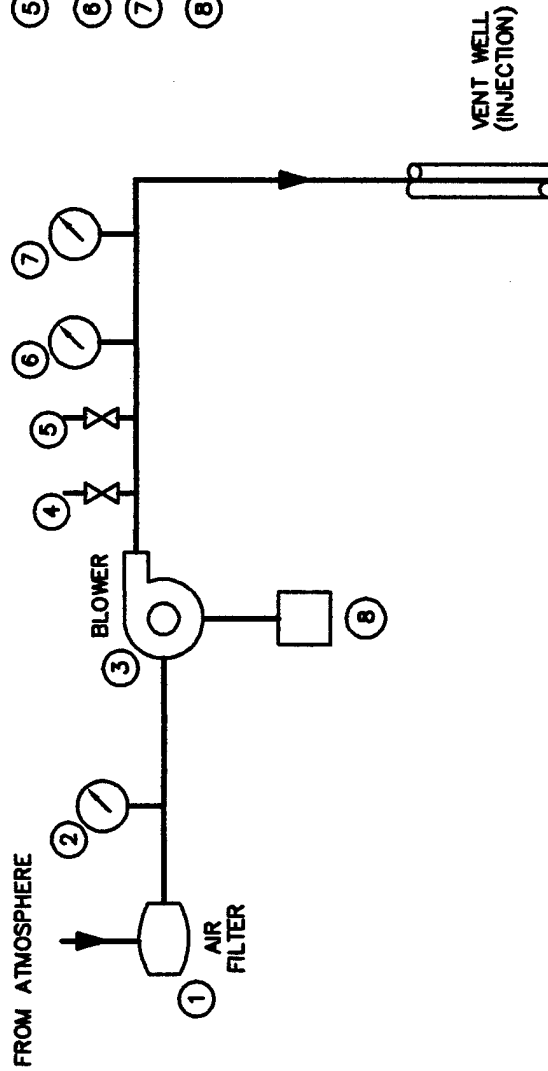

FIGURE 1.5

AS-BUILT  
 EXTENDED PILOT TEST BLOWER  
 SYSTEM FOR AIR INJECTION  
 PS-3, PUMPHOUSE 2

MALMSTROM AFB, MONTANA

ENGINEERING-SCIENCE, INC.  
 Denver, Colorado



## **1.2 PS-4, Bulk POL Storage Area**

Three MPs and a blower unit were installed at the Bulk POL Storage Area. Locations of the VW and MPs completed at the site are shown on Figure 1.6. The hydrogeologic cross-section for the site is shown on Figure 1.7. Boring logs for the MPs and VW are included in Appendix A. The background MP for this site, installed near the southeastern boundary of the base, is screened at 4 feet bgs.

### **1.2.1 Air Injection Vent Well**

The air injection VW, designated as Biovent Bulk POL, was installed by HDR Engineering, Inc. following procedures described in the AFCEE bioventing protocol document (Hinchee et al., 1992). Figure 1.8 shows construction details for the VW. The VW was installed in contaminated soils with the screened interval extending from 5 to 10 feet bgs. The groundwater surface at this site was approximately 3.75 feet bgs prior to the pilot test. The VW was constructed using 4-inch-diameter, Schedule 40 PVC casing, with 5 feet of 0.04-inch slotted PVC screen. The annular space between the well casing and borehole was filled with 8-12 grain size silica sand from the bottom of the borehole to approximately 1 foot above the well screen. Two feet of granular bentonite was placed above the sand, hydrated in place, and overlaid with a concrete seal to the existing gravel surface (HDR Engineering, Inc., 1993).

### **1.2.2 Monitoring Points**

The MP screens were installed at 3.5- and 7.5-foot depths. The three MPs (MPA, MPB, and MPC) at this site were constructed as shown in Figure 1.9. Each was constructed using 6-inch sections of 1-inch-diameter PVC well screen and 0.25-inch PVC riser pipes extending to the ground surface. At the top of each riser, a ball valve and a 3/16-inch hose barb were installed. The top of each MP was completed with a flush-mounted metal well protector set in concrete. Thermocouples were installed at the 3.5- and 7.5-foot depths at MPC to measure soil temperature variations.

### **1.2.3 Blower Unit**

A 3-horsepower Roots® positive-displacement blower unit was used at the Bulk POL Storage Area for the initial pilot test, and a 1-horsepower Gast® regenerative blower unit was installed at the site for the extended pilot test. The initial pilot test blower was energized by 208-volt, single-phase, 20-amp power from a temporary disconnect inside the electrical control room of the POL storage area. The extended pilot test unit is wired to a newly-installed explosion-proof disconnect inside the blower enclosure. The 1-horsepower extended pilot test blower was configured to inject approximately 18 scfm for the extended pilot test. The configuration, instrumentation, and specifications for the extended pilot test unit are shown on Figure 1.10. Prior to departing from the site, ES engineers provided an O&M briefing checklist and blower maintenance manual to Base personnel. A copy of the checklist is provided in Appendix B.

SB-09

SB-08

MW-06

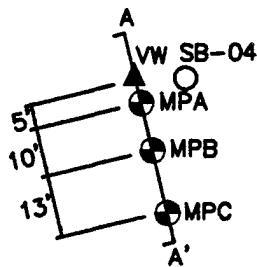

SB-05

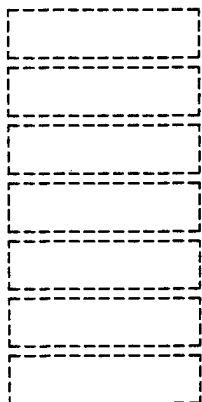

AVGAS USTs  
(ABANDONED IN PLACE)

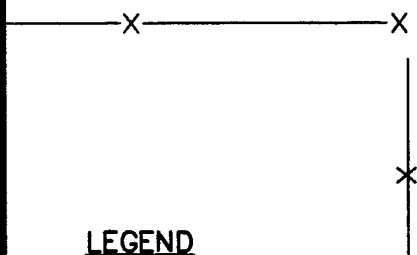

**LEGEND**

- ▲ VENT WELL
- SB-05 ○ SOIL BORING
- MW-06 ⊕ MONITORING WELL
- MPA ⊕ VAPOR MONITORING POINT
- X-X- FENCE
- A-A' PROFILE



NOTE:  
LOCATIONS OF ALL WELLS AND SOIL BORINGS ARE APPROXIMATE.

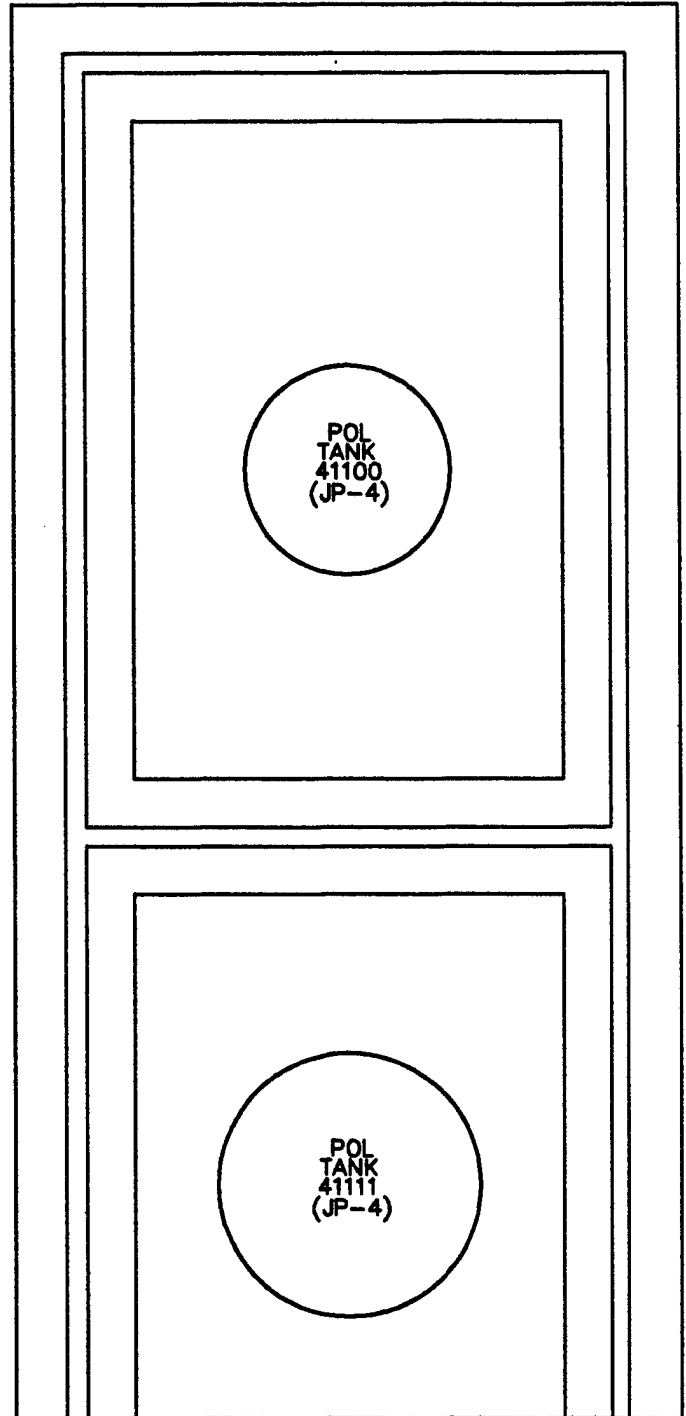

**FIGURE 1.6**

**AS-BUILT  
VENT WELL AND  
MONITORING POINT LOCATIONS  
PS-4, BULK POL STORAGE AREA**

Malmstrom AFB, Montana

**ENGINEERING-SCIENCE, INC.**

Denver, Colorado

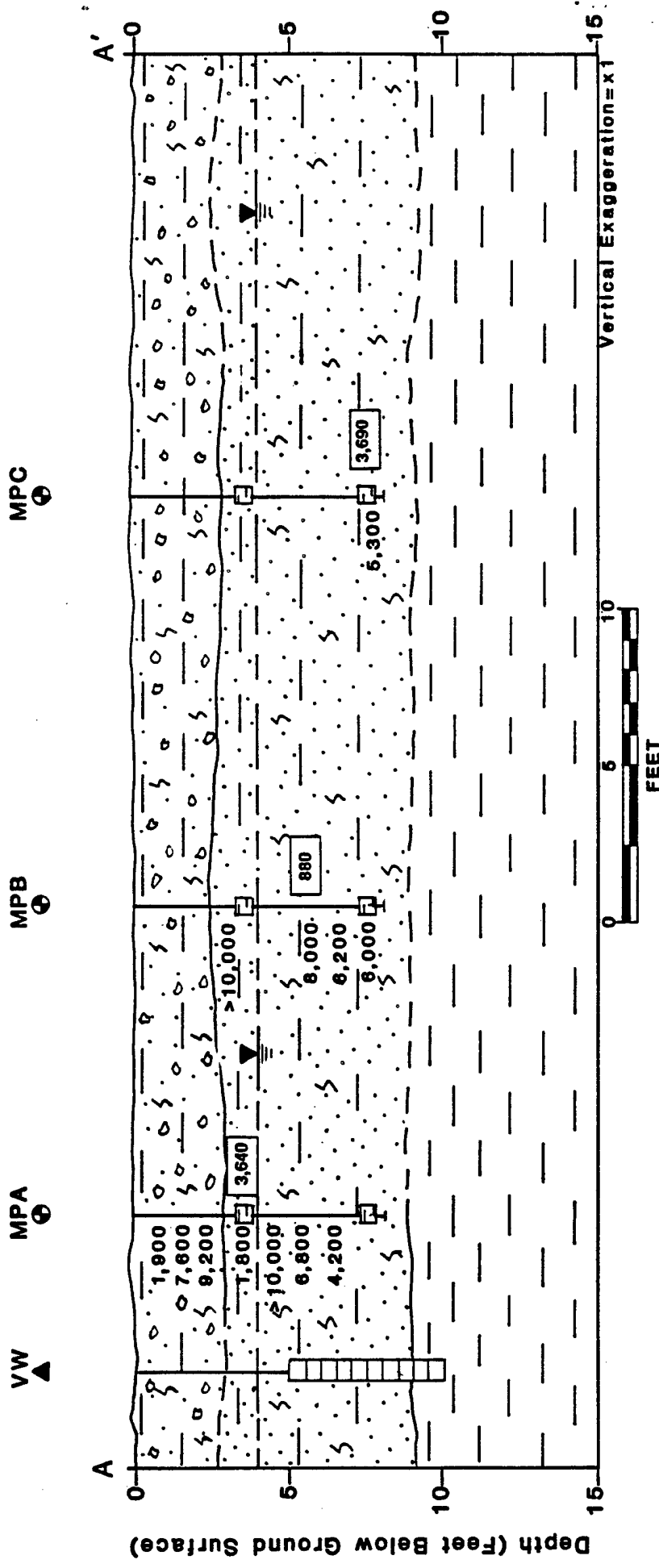

LITHOLOGIC DESCRIPTION

- GRAVEL WITH SAND
- CLAYEY, SILTY SAND
- CLAY
- SILT AND CLAY

LEGEND

- VW ▲ VENT WELL
- MPA ⊕ MONITORING POINT
- 6,800 FIELD SCREENING RESULTS FOR TOTAL VOLATILE HYDROCARBONS (ppmv)
- 3,640 LABORATORY RESULTS FOR SOIL TOTAL PETROLEUM HYDROCARBONS (mg/kg)
- GROUNDWATER ELEVATION
- GEOLOGIC CONTACT, DASHED WHERE INFERRED
- MONITORING POINT SCREENED INTERVAL
- SCREENED WELL INTERVAL

FIGURE 1.7

HYDROGEOLOGIC CROSS-SECTION  
PS-4, BULK POL STORAGE AREA

MALMSTROM AFB, MONTANA

**ENGINEERING-SCIENCE, INC.**

Denver, Colorado

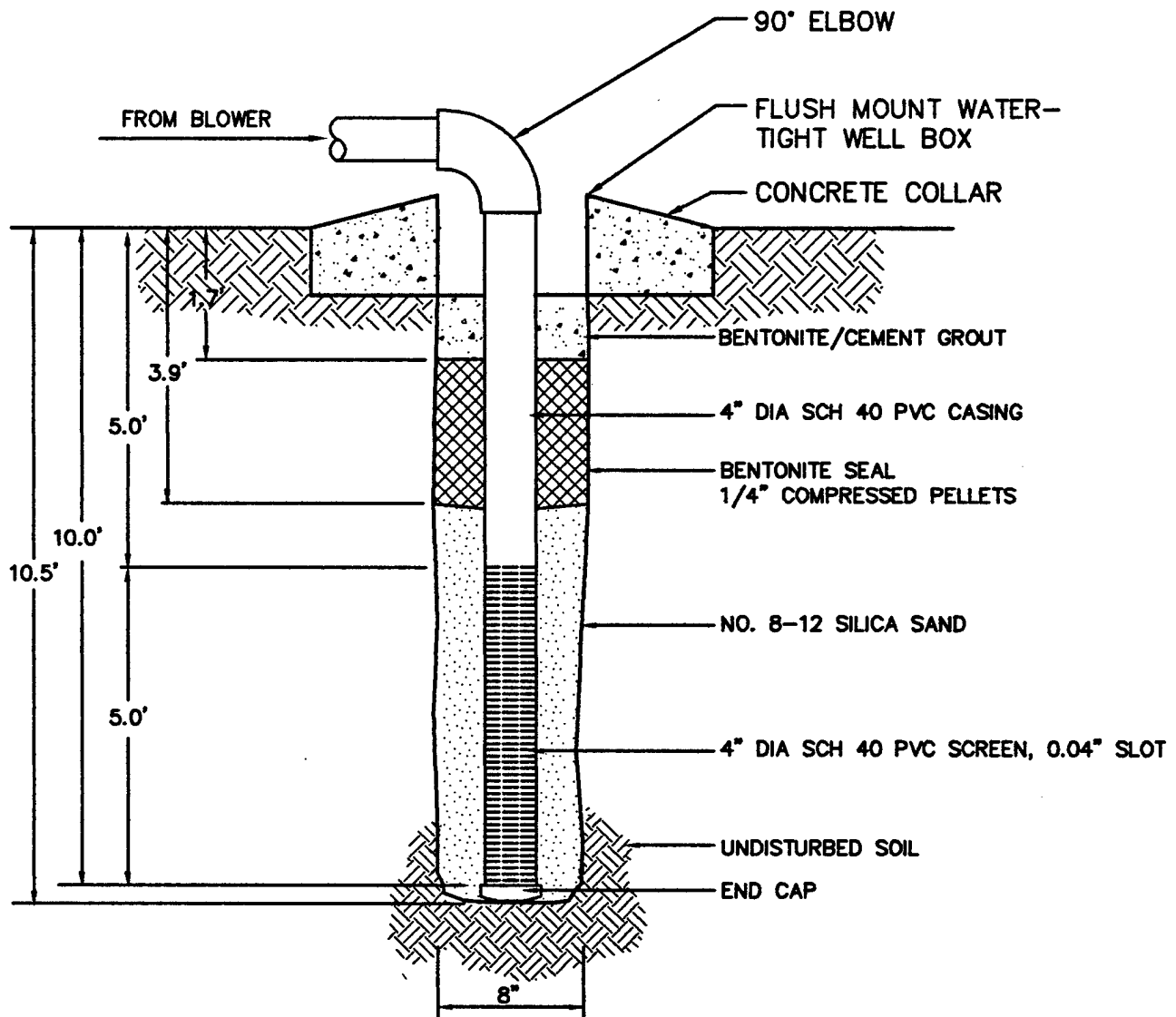

NOT TO SCALE

**FIGURE 1.8**  
**AS-BUILT INJECTION/VENT**  
**WELL CONSTRUCTION DETAIL**  
**PS-4,BULK POL STORAGE AREA**

MALMSTROM AFB, MONTANA

**ENGINEERING-SCIENCE, INC.**

Denver, Colorado

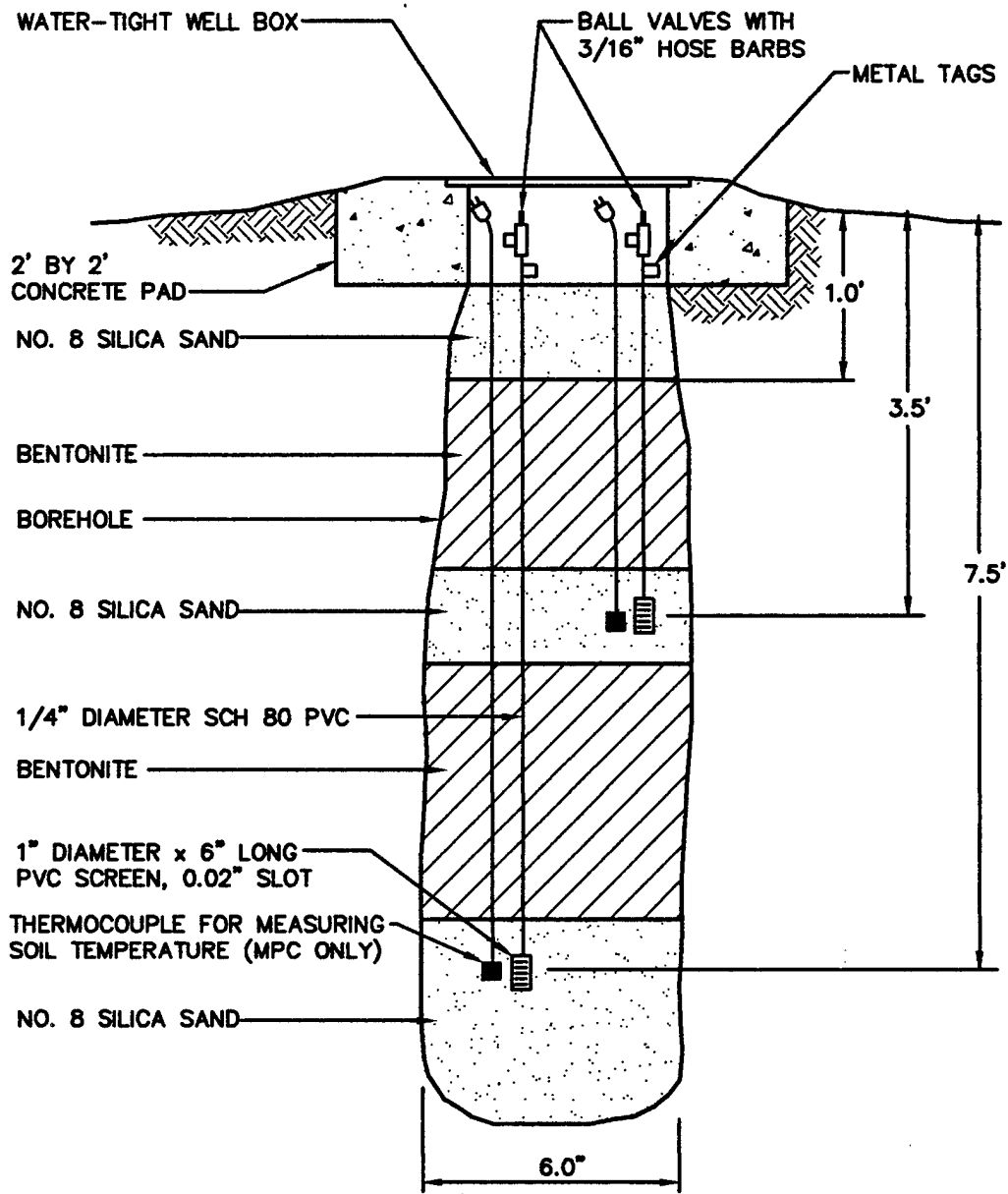

NOT TO SCALE

**FIGURE 1.9**  
**TYPICAL AS-BUILT**  
**MONITORING POINT**  
**CONSTRUCTION DETAIL**  
**PS-4, BULK POL STORAGE AREA**

Malmstrom AFB, Montana

**ENGINEERING-SCIENCE, INC.**

Denver, Colorado

**LEGEND**

- ① INLET AIR FILTER - SOLBERG® F-18P-150
- ② VACUUM GAUGE (in H<sub>2</sub>O)
- ③ 1-HP BLOWER - GAST® R4110N-50
- ④ MANUAL PRESSURE RELIEF (BLEED) VALVE
- ⑤ AUTOMATIC PRESSURE RELIEF VALVE
- ⑥ PRESSURE GAUGE (in H<sub>2</sub>O)
- ⑦ TEMPERATURE GAUGE (°F)
- ⑧ BREAKER BOX - 230V/SINGLE PHASE/30 AMP

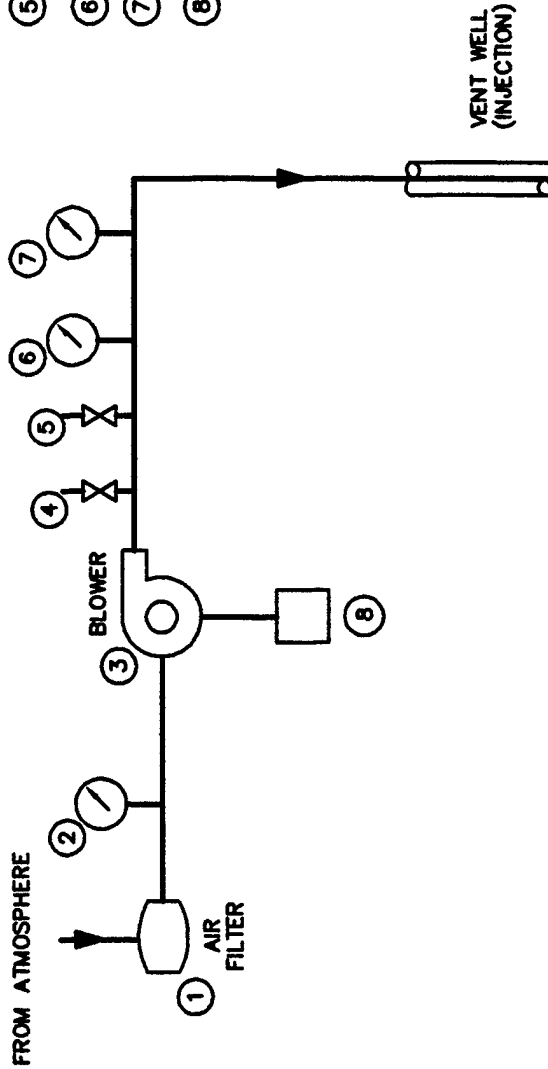

FIGURE 1.10

AS- BUILT  
 EXTENDED PILOT TEST BLOWER  
 SYSTEM FOR AIR INJECTION  
 PS-4, BULK POL STORAGE AREA

Malmstrom AFB, Montana

ENGINEERING-SCIENCE, INC.  
 Denver, Colorado



## **2.0 PILOT TEST SOIL AND SOIL GAS SAMPLING RESULTS**

### **2.1 PS-3, Pumphouse 2**

#### **2.1.1 Sampling Results**

Soils at this site generally consist of clay with sand lenses and some gravel (Figure 1.2). Bedrock was not encountered during drilling for this pilot test and is not shown on the figure. The general soil profile consists of clayey gravel fill in the upper 1 foot, clay with sand lenses and traces of gravel from approximately 1 to 5 feet bgs, and saturated sandy clay from approximately 5 to 8 feet bgs. Groundwater occurred at 5.2 feet bgs in the completed VW. Boring logs for the MPs and VW are included in Appendix A.

Hydrocarbon contamination at this site appears to extend from approximately 2 to at least 8 feet bgs. Contaminated soils were identified based on odor and total volatile hydrocarbon (TVH) field screening results. Contaminated soils were encountered in all MP boreholes, with the greatest contamination occurring at 2 feet bgs in MPA. Soils at these locations had a strong hydrocarbon odor.

Soil samples for laboratory analysis were collected from a hand-driven stainless steel sampler with a 2-inch-diameter brass liner. Soil samples were screened for TVH using a GasTech® TVH analyzer to determine the presence of contamination and to select soil samples for laboratory analysis. Soil samples for laboratory analysis were collected from a depth of 2 feet from MPA, 3.5 feet from MPB, and 5.5 feet from MPC. Soil gas samples were collected by extracting soil gas from a depth of 4 feet bgs from MPA, MPB, and MPC.

Soil samples were shipped via Federal Express® to the Pace, Inc. laboratory in Novato, California for chemical and physical analysis. Soil samples were analyzed for total recoverable petroleum hydrocarbons (TRPH); benzene, toluene, ethylbenzene, and xylenes (BTEX); iron; alkalinity; total Kjeldahl nitrogen (TKN); and several physical parameters. Soil gas samples were shipped via Federal Express® to Air Toxics, Inc. in Folsom, California for TVH and BTEX analysis. The results of these analyses are provided in Table 2.1.

#### **2.1.2 Exceptions To Test Protocol Document Procedures**

Procedures described in the protocol document (Hinchee et al., 1992) were used to complete treatability tests at Pumphouse 2 with several exceptions. Soil and soil gas samples were not collected from the VW because it was constructed prior to the pilot test and because of the small area of screen remaining exposed above the groundwater surface. Soil and soil gas samples were collected from each of the three MPs installed at the site. The deepest screened intervals of the MPs were completed below the groundwater surface, rendering the intervals unusable during the initial pilot test. It is believed that the groundwater surface will decline and the points may be serviceable for 6-month and 1-year testing.

#### **2.1.3 Field Quality Assurance/Quality Control (QA/QC) Results**

To assess the accuracy of the primary laboratory analysis, two field duplicates were collected (MPA-2 and MPB-3) at Pumphouse 2 and sent to Evergreen Analytical, Inc. in Wheat Ridge, Colorado. The relative percent differences (RPDs) between analytes in the duplicate and the primary sample were examined to determine the representativeness and

**TABLE 2.1**  
**SOIL AND SOIL GAS ANALYTICAL RESULTS**  
**PS-3, PUMPHOUSE 2**  
**MALMSTROM AFB, MONTANA**

Analyte (Units) <sup>a/</sup>	Sample Location-Depth (feet below ground surface)		
<u>Soil Gas Hydrocarbons</u>	<u>MPA-4</u>	<u>MPB-4</u>	<u>MPC-4</u>
TVH (ppmv)	5,400	6,900	14,000
Benzene (ppmv)	ND <sup>b/</sup>	ND	19
Toluene (ppmv)	ND	ND	ND
Ethylbenzene (ppmv)	9	5.2	13
Xylenes (ppmv)	11	9.8	15
<u>Soil Hydrocarbons</u>	<u>MPA-2</u>	<u>MPB-3.5</u>	<u>MPC-5.5</u>
TRPH (mg/kg)	300	270	150
Benzene (mg/kg)	ND	ND	ND
Toluene (mg/kg)	0.71	ND	1.1
Ethylbenzene (mg/kg)	1.2	2.2	1.5
Xylenes (mg/kg)	3.6	3.1	4.4
<u>Soil Inorganics</u>	<u>MPA-2</u>	<u>MPB-3.5</u>	<u>MPC-5.5</u>
Iron (mg/kg)	17,600	19,600	19,100
Alkalinity ( mg/kg as CaCO <sub>3</sub> )	1,010	970	480
pH (units)	8.1	8.6	8.4
TKN (mg/kg)	310	630	340
Phosphates (mg/kg)	430	420	650
<u>Soil Physical Parameters</u>	<u>MPA-2</u>	<u>MPB-3.5</u>	<u>MPC-5.5</u>
Moisture (% wt.)	23	22	20
Gravel (%)	6.4	2.3	1.7
Sand (%)	43.7	38.2	31.0
Silt (%)	22.9	27.3	41.2
Clay (%)	27.0	32.2	26.2
Soil Temperature (°F)	<u>MPA-4</u> 62.5	<u>MPA-6.5</u> 64.0	

a/ mg/kg=milligrams per kilogram; ppmv=parts per million, volume per volume; CaCO<sub>3</sub>=calcium carbonate; TKN=total Kjeldahl nitrogen; TVH=total volatile hydrocarbons; TRPH=total recoverable petroleum hydrocarbons; wt.=weight; °F = degrees Fahrenheit

b/ ND=not detected.

c/ NS=not sampled.

precision of the samples. Laboratory results for samples MPA-2 and MPB-3.5, and the RPDs are presented in Table 2.2. As indicated in the table, there is a large discrepancy between the two laboratory results. The analyses of the primary laboratory have been accepted in order to retain continuity when comparing results from other bases within the AFCEE bioventing initiative. The primary laboratory (PACE, Inc.) will also be used for the one year soil analysis. It is not known which set of values is more accurate, but it can be shown that in a worst case scenario, the concentrations of TRPH are 300 milligrams per kilogram (mg/kg) or below. Additionally, Table 2.2 presents the results of duplicate analysis performed by Air Toxics, Inc. These results indicate excellent laboratory reproducibility.

## **2.2 PS-4, Bulk POL Storage Area**

### **2.2.1 Sampling Results**

Soils at this site consist primarily of sand with silt and clay, with increasing clay content with depth (Figure 1.7). Bedrock was not encountered during drilling for this pilot test and is not shown in the figure. The general soil profile consists of clayey silty gravel fill in the upper 2 feet, and clayey silty sand with traces of gravel from approximately 3 to 9 feet bgs. Previous investigations indicate clay materials from 9 feet bgs to at least 21 feet bgs. Groundwater occurred at approximately 4 feet bgs in the MP boreholes. Boring logs for the MPs and VW are included in Appendix A.

Hydrocarbon contamination at this site appears to extend from about 2 to at least 8 feet bgs. A sheen of free product was evident on the sampling device while sampling soils below the groundwater level. Contaminated soils were identified based on odor and TVH field screening results. Contaminated soils were encountered in all MP boreholes with the greatest contamination occurring at 7 feet bgs at MPC. Soils at these locations had a strong hydrocarbon odor.

Soil samples for laboratory analysis were collected from a hand-driven stainless steel sampler with a 2-inch-diameter brass liner. Soil samples were screened for TVH using a GasTech® analyzer to determine the presence of contamination and to select soil samples for laboratory analysis. Soil samples for laboratory analysis were collected from a depth of 3 feet from MPA, 5 feet from MPB, and 7 feet from MPC. A background soil sample was collected from the background point near the southeastern edge of the Base. The background sample was collected from approximately 4 feet bgs and placed into a glass container with a Teflon® seal. Soil gas samples were collected by extracting soil gas from a depth of 3.5 feet bgs from MPA, MPB, and MPC.

Soil samples were shipped via Federal Express® to the Pace, Inc. laboratory in Novato, California for chemical and physical analysis. Soil samples from the MPs were analyzed for TRPH, BTEX, iron, alkalinity, TKN, and several physical parameters. The background soil sample was analyzed only for nutrients. Soil gas samples were shipped via Federal Express® to Air Toxics, Inc. in Folsom, California for TVH and BTEX analysis. The results of these analyses are provided in Table 2.3. The BTEX/TRPH ratio in these soil samples is relatively high which is typical of a higher-grade fuel such as aviation gasoline (AVGAS). The soil gas samples contained no benzene and little toluene which is unusual for soils that do contain benzene and toluene.

**TABLE 2.2**  
**FIELD AND LABORATORY QA/QC ANALYTICAL RESULTS**  
**PS-3, PUMPHOUSE 2**  
**MALMSTROM AFB, MONTANA**

Analyte (Units) <sup>a/</sup>	Primary Sample	Duplicate	RPD <sup>b/</sup>
<u>Field QA/QC Results</u>			
<u>Soil Hydrocarbons</u>	<u>MPA-2</u>	<u>MPA-2</u>	
TRPH (mg/kg)	300	<3.3	196%
	<u>MPB-3.5</u>	<u>MPB-3.5</u>	
TRPH (mg/kg)	270	<3.3	195%
<u>Laboratory QA/QC Results</u>			
<u>Soil Gas Hydrocarbons</u>	<u>MPA-4</u>	<u>MPA-4 Duplicate</u>	
TVH (ppmv)	5,400	5,400	0%
Benzene (ppmv)	ND <sup>c/</sup>	ND	0%
Toluene (ppmv)	ND	ND	0%
Ethylbenzene (ppmv)	9.0	9.1	1%
Xylenes (ppmv)	11	11	0%

- a/ TRPH = total recoverable petroleum hydrocarbons; mg/kg = milligrams per kilogram; TVH = total volatile hydrocarbons; ppmv = part per million, volume per volume.
- b/ RPD = relative percent difference between primary sample and field duplicate. RPDs for sample MPA-2 and MPB-3.5 were calculated using detection limit (3.3 mg/kg) for duplicate value.
- c/ ND = not detected.

**TABLE 2.3**  
**SOIL AND SOIL GAS ANALYTICAL RESULTS**  
**PS-4, BULK POL STORAGE AREA**  
**MALMSTROM AFB, MONTANA**

Analyte (Units) <sup>a/</sup>	Sample Location-Depth (feet below ground surface)		
<u>Soil Gas Hydrocarbons</u>	<u>MPA-3.5</u>	<u>MPB-3.5</u>	<u>MPC-3.5</u>
TVH (ppmv)	34,000	49,000	54,000
Benzene (ppmv)	ND <sup>b/</sup>	ND	ND
Toluene (ppmv)	ND	ND	34
Ethylbenzene (ppmv)	8.6	14	12
Xylenes (ppmv)	21	52	40
<u>Soil Hydrocarbons</u>	<u>MPA-3</u>	<u>MPB-5</u>	<u>MPC-7</u>
TRPH (mg/kg)	3,640	880	3,690
Benzene (mg/kg)	0.79	ND	12
Toluene (mg/kg)	42	30	310
Ethylbenzene (mg/kg)	15	7.2	43
Xylenes (mg/kg)	84	45	240
<u>Soil Inorganics</u>	<u>MPA-3</u>	<u>MPB-5</u>	<u>MPC-7</u>
Iron (mg/kg)	10,600	12,300	13,300
Alkalinity (mg/kg as CaCO <sub>3</sub> )	950	740	810
pH (units)	8.5	8.2	8.1
TKN (mg/kg)	660	530	390
Phosphates (mg/kg)	340	330	280
<u>Soil Physical Parameters</u>	<u>MPA-3</u>	<u>MPB-5</u>	<u>MPC-7</u>
Moisture (% wt.)	18	12	21
Gravel (%)	2.3	2.2	0.5
Sand (%)	66.0	68.2	75.2
Silt (%)	14.2	16.0	10.5
Clay (%)	17.5	13.7	13.8
Soil Temperature (°F)	<u>MPC-3.5</u> 52.8	<u>MPC-7.5</u> 55.8	

a/ mg/kg= milligrams per kilogram; ppmv=parts per million, volume per volume; CaCO<sub>3</sub>=calcium carbonate; TKN=total Kjeldahl nitrogen; TVH=total volatile hydrocarbons; TRPH=total recoverable petroleum hydrocarbons; wt.=weight; °F = degrees Fahrenheit

b/ ND=not detected

## **2.2.2 Exceptions To Test Protocol Document Procedures**

Procedures described in the protocol document (Hinchee et al., 1992) were used to complete treatability tests at the Bulk POL Storage Area with several exceptions. Soil and initial soil gas samples were not collected from the VW because the VW was constructed prior to the pilot test, and because the screen was entirely covered by groundwater. Soil and soil gas samples were collected from each of the three MPs installed at the site. Thermocouples at this site were installed at MPC instead of MPA. The deepest screened intervals of the MPs were completed below the groundwater surface, rendering the intervals unusable during the initial pilot test. It is believed that the groundwater surface will decline and the points will be serviceable for 6-month and 1-year testing.

## **3.0 PILOT TEST RESULTS**

### **3.1 PS-3, Pumphouse 2**

#### **3.1.1 Initial Soil Gas Chemistry**

Prior to initiating any air injection, all exposed MPs were purged until oxygen levels had stabilized, and initial oxygen, carbon dioxide, and TVH concentrations were sampled using portable gas analyzers as described in the protocol document (Hinchee et al., 1992). At all MP screened intervals sampled, microorganisms had significantly depleted soil gas oxygen supplies, indicating significant biological activity and soil contamination. Table 3.1 summarizes the initial soil gas chemistry.

#### **3.1.2 Air Permeability**

An air permeability test was conducted according to protocol document procedures. Air was injected into the VW for 22.5 hours at a rate of approximately 17.5 scfm and an average pressure of 4 pounds per square inch (psi). The maximum pressure response at each MP is listed in Table 3.2. The pressure measured at the MPs gradually increased at an irregular rate throughout the period of air injection. Due to the long-term pressure response, the HyperVentilate® method of determining air permeability was selected. A soil gas permeability value of 18 darcys, typical for sandy-clay soils, was calculated for this site. A radius of pressure influence of at least 25 feet was observed at the 4- and 6.5-foot depths.

#### **3.1.3 Oxygen Influence**

The depth and radius of oxygen increase in the subsurface resulting from air injection into the central VW during pilot testing is the primary design parameter for full-scale bioventing systems. Optimization of full-scale and multiple VW systems requires pilot testing to determine the volume of soil that can be oxygenated at a given flow rate and VW screen configuration.

Table 3.3 presents the change in soil gas oxygen levels that occurred during the 22.5-hour air permeability test. This period of air injection at approximately 17.5 scfm produced changes in soil gas oxygen levels at two of the three functioning MP screened intervals. Based on measured changes in oxygen levels, it is anticipated that the radius of influence for a long-term bioventing system at this site will exceed 25 feet at all depths above the groundwater table. This is noteworthy because soils contained high moisture levels and air porosity should significantly increase over time, improving oxygen

**TABLE 3.1**  
**INITIAL SOIL GAS CHEMISTRY**  
**PS-3, PUMPHOUSE 2**  
**MALMSTROM AFB, MONTANA**

Sample Location	Depth (ft/bgs) <sup>a/</sup>	O <sub>2</sub> (%)	CO <sub>2</sub> (%)	Field TVH <sup>b/</sup> (ppmv) <sup>d/</sup>	Lab TVH (ppmv) <sup>e/</sup>	Soil TRPH <sup>c/</sup> (mg/kg) <sup>f/</sup>
MPA	4	0.5	16.2	> 20,000	5,400	NS <sup>g/</sup>
MPB	4	1.7	12.2	> 20,000	6,900	270
MPC	4	0.6	12.9	> 20,000	14,000	NS

- a/ ft/bgs= feet below ground surface.
- b/ TVH=total volatile hydrocarbons.
- c/ TRPH=total recoverable petroleum hydrocarbon.
- d/ Field screening results, in parts per million, volume per volume (ppmv).
- e/ Laboratory results.
- f/ Laboratory soil results, in milligrams per kilogram (mg/kg).
- g/ NS=not sampled.

**TABLE 3.2**  
**MAXIMUM PRESSURE RESPONSE**  
**AIR PERMEABILITY TEST**  
**PS-3, PUMPHOUSE 2**  
**MALMSTROM AFB, MONTANA**

	Distance from vent well (VW) (feet)					
	5 (MPA)		15 (MPB)		25 (MPC)	
Depth (feet)	4	6.5	4	6.5	4	6.5
Time (minutes)	10	NS <sup>a/</sup>	16	35	1350	26
Max Press. <sup>b/</sup> (inches H <sub>2</sub> O)	115	NS	31.4	48.0	13.7	1.0

<sup>a/</sup> NS= Not sampled. MPA-6.5 was purging water throughout the test.  
<sup>b/</sup> maximum pressure.

**TABLE 3.3**  
**INFLUENCE OF AIR INJECTION AT VENT WELL**  
**ON MONITORING POINT OXYGEN LEVELS**  
**PS-3, PUMPHOUSE 2**  
**MALMSTROM AFB, MONTANA**

MP	Distance From VW (feet)	Depth(feet)	Initial O <sub>2</sub> (%)	Final O <sub>2</sub> (%) Permeability Test <sup>a/</sup>
A	5	4	0.5	NS <sup>b/</sup>
B	15	4	1.7	16.8
C	25	4	0.6	11.0

a/ Reading taken at end of 22.5-hour air permeability test.  
b/ NS= Not sampled.

distribution. Monitoring during the extended pilot test at this site will better define the effective treatment radius.

#### **3.1.4 *In Situ* Respiration Rates**

The *in situ* respiration test was performed by injecting air into three MP screened intervals (MPA-4, MPB-4, and MPC-4) for a 23-hour period. Oxygen loss and other changes in soil gas composition over time were then measured at these intervals. Oxygen, TVH, and carbon dioxide were measured for a period of approximately 5.5 hours following air injection. The measured oxygen losses were then used to calculate biological oxygen utilization rates. The results of *in situ* respiration testing for the MP intervals at this site are presented in Figures 3.1 through 3.3. Table 3.4 provides a summary of the oxygen utilization rates.

A helium tracer was injected with the air during the test. However, at some point during the injection, the helium supply was depleted. As a result, no helium concentrations are presented in the figures.

Oxygen loss occurred at extremely high rates, ranging from 0.046 percent per minute at MPB-4, to 0.057 percent per minute at MPC-4. At MPC-4, oxygen dropped from 20.5 percent to 1.0 percent in 330 minutes.

Based on these oxygen utilization rates, an estimated 2,240 to 2,780 milligrams (mg) of fuel per kilogram (kg) of soil can be degraded each year at this site. This conservative estimate is based on an average air-filled porosity of approximately 0.024 liter per kg of soil, and a ratio of 3.5 mg of oxygen consumed for every 1 mg of fuel biodegraded. If oxygen can be uniformly distributed in these soils excellent long-term remediation is predicted.

#### **3.1.5 Potential Air Emissions**

The long-term potential for air emissions from full-scale bioventing operations at this site is moderate because of the relatively permeable sandy-clay soil and the shallow injection depth. The injection rate for the pilot test was set at approximately 10 scfm so that emissions would be minimal. Additionally, accumulated vapors will move slowly outward from the air injection VW, and vapor-phase hydrocarbons will be biodegraded as they move horizontally through the soil.

### **3.2 PS-4, Bulk POL Storage Area**

#### **3.2.1 Initial Soil Gas Chemistry**

Prior to initiating any air injection, all above the water table MPs were purged until oxygen levels had stabilized, and initial oxygen, carbon dioxide, and TVH concentrations were sampled using portable gas analyzers, as described in the protocol document (Hinchee et al., 1992). At all MP screened intervals above the groundwater surface, microorganisms had completely depleted soil gas oxygen supplies, indicating significant biological activity and soil contamination. Table 3.5 summarizes the initial soil gas chemistry.

#### **3.2.2 Air Permeability**

An air permeability test was conducted according to protocol document procedures. Air was injected into the VW for 14.3 hours at a flow rate of approximately 15 scfm and an

Figure 3.1  
 Respiration Test  
 Oxygen Concentrations  
 Pumphouse 2, MPA-4  
 Malmstrom AFB, Montana

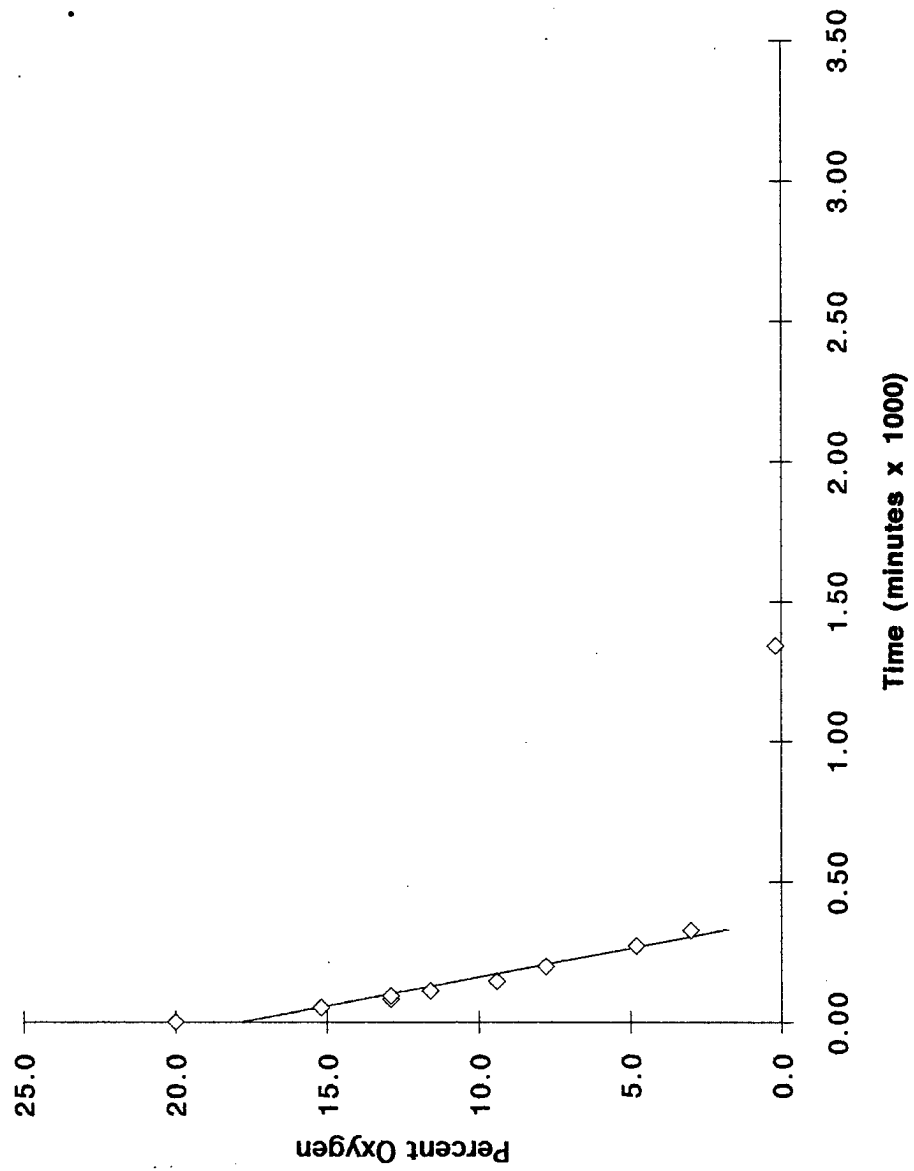

◇ Percent Oxygen  
 — k = 0.04869 %/min.  
 (oxygen utilization rate)

Figure 3.2  
 Respiration Test  
 Oxygen Concentrations  
 Pumphouse 2, MPB-4  
 Malmstrom AFB, Montana

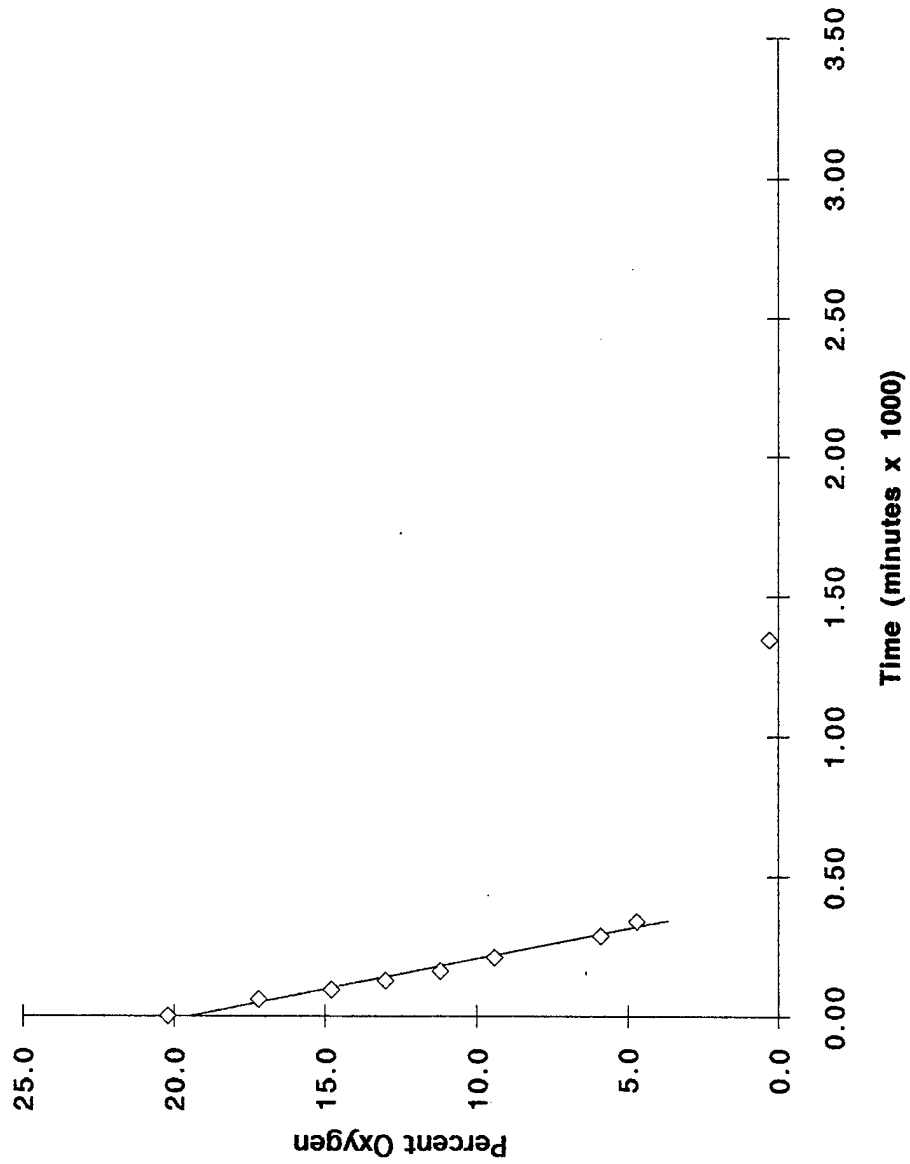
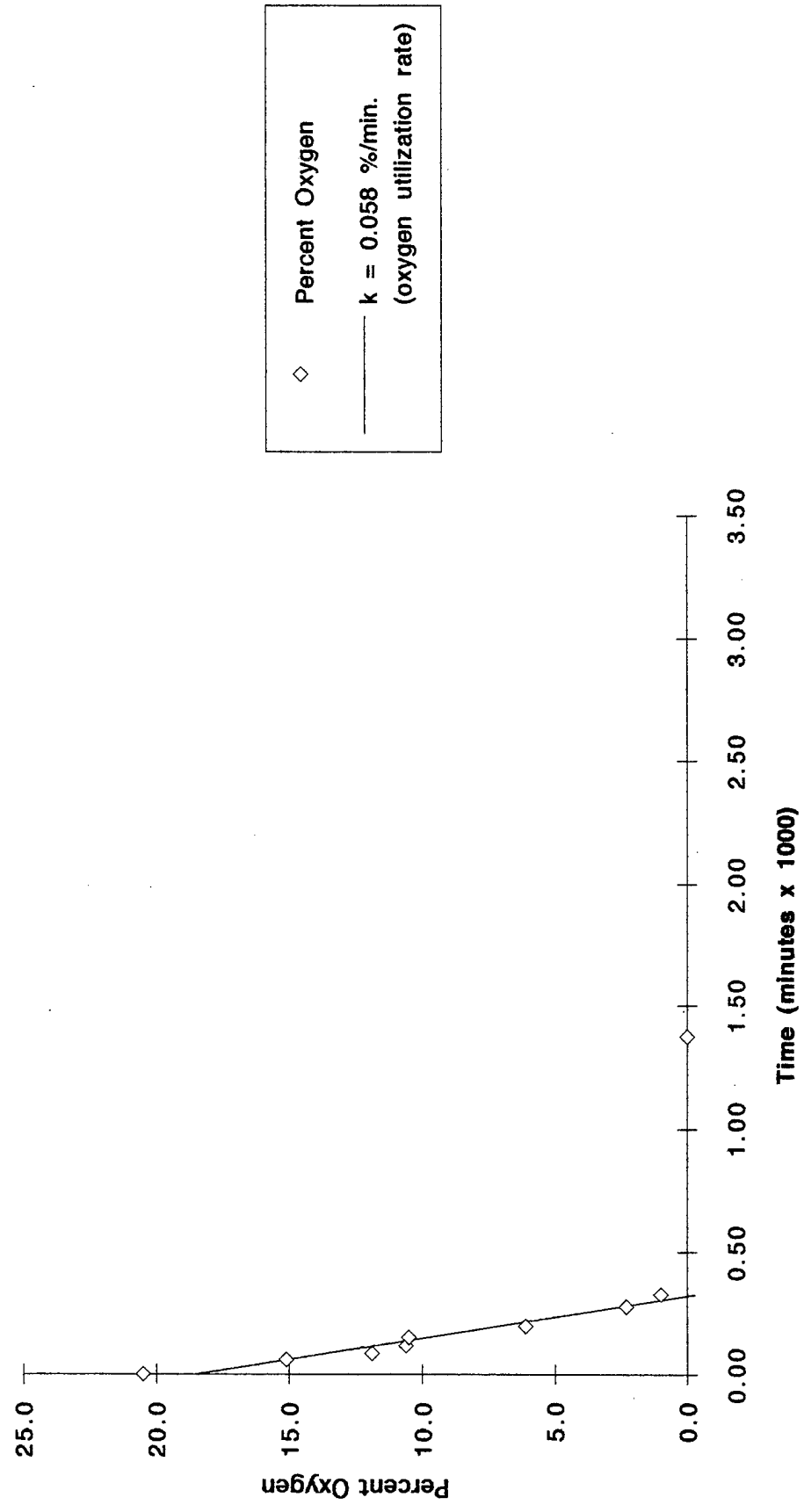

Figure 3.3  
 Respiration Test  
 Oxygen Concentrations  
 Pumphouse 2, MPC-4  
 Malmstrom AFB, Montana



**TABLE 3.4**  
**OXYGEN UTILIZATION RATES**  
**PS-3, PUMPHOUSE 2**  
**MALMSTROM AFB, MONTANA**

Location	O <sub>2</sub> Loss <sup>a/</sup> (Percent)	Test <sup>b/</sup> Duration (minutes)	O <sub>2</sub> Utilization <sup>c/</sup> Rate (Percent/minute)
MPA-4	17.0	330	0.049
MPB-4	15.5	340	0.046
MPC-4	19.5	330	0.058

a/ Actual measured oxygen loss.

b/ Elapsed time from beginning of test to time when minimum oxygen concentration was measured.

c/ Values based on best fit lines (Figures 3.1 through 3.3).

**TABLE 3.5**  
**INITIAL SOIL GAS CHEMISTRY**  
**PS-4, BULK POL STORAGE AREA**  
**MALMSTROM AFB, MONTANA**

Sample Location	Depth (feet)	O <sub>2</sub> (%)	CO <sub>2</sub> (%)	Field TVH <sup>a/</sup> (ppmv) <sup>c/</sup>	Lab TVH (ppmv) <sup>d/</sup>	Soil TRPH <sup>b/</sup> (mg/kg) <sup>e/</sup>
MPA	3.5	0.0	10.5	> 40,000	34,000	3,640
MPB	3.5	0.0	12.7	> 40,000	49,000	880
MPC	3.5	0.0	12.8	> 40,000	54,000	3,690

- a/ TVH=total volatile hydrocarbons.  
b/ TRPH=total recoverable hydrocarbons.  
c/ Field screening results, in parts per million, volume per volume (ppmv).  
d/ Laboratory results.  
e/ Laboratory soil results, in milligrams per kilogram (mg/kg).

average pressure of 5.3 psi. The maximum pressure response at each MP are presented in Table 3.6. The pressure measured at the MPs increased irregularly during the period of air injection. Due to the long-term pressure response, the HyperVentilate® method of determining air permeability was selected. A soil gas permeability value of 18 darcys, typical for sandy-clay soils, was calculated for this site. A radius of pressure influence of at least 28 feet was observed at the 3.5 foot depth.

### 3.2.3 Oxygen Influence

The depth and radius of oxygen increase in the subsurface resulting from air injection into the central VW during pilot testing is the primary design parameter for full-scale bioventing systems. Optimization of full-scale and multiple VW systems requires pilot testing to determine the volume of soil that can be oxygenated at a given flow rate and VW screen configuration.

Table 3.7 presents the change in soil gas oxygen levels that occurred during the 14.3-hour air permeability test. This period of air injection at 15 scfm produced changes in soil gas oxygen levels at each of the three functioning MP screened intervals. Based on measured changes in oxygen levels, it is anticipated that the radius of influence for a long-term bioventing system at this site will exceed 25 feet at all depths above the groundwater table. Monitoring during the extended pilot test at this site will better define the effective treatment radius.

### 3.2.4 *In Situ* Respiration Rates

The *in situ* respiration test was performed by injecting air into three MP screened intervals (MPA-3.5, MPB-3.5, and MPC-3.5) for a 20-hour period. Oxygen loss and other changes in soil gas composition over time were then measured at these intervals. Oxygen, TVH, and carbon dioxide were measured for a period of 20 hours following air injection. The measured oxygen loss was then used to calculate the biological oxygen utilization rate. The results of *in situ* respiration testing at selected points at this site are presented in Figures 3.4 through 3.6. Table 3.8 provides a summary of the oxygen utilization rates.

A helium tracer was injected with the air during the test. Due to a conflict with fuel loading operations in the area, the injection period was extended unexpectedly and the helium supply was depleted before respiration readings could begin. As a result, no helium concentrations are presented in the figures.

Oxygen loss occurred at moderate rates, ranging from 0.011 percent per minute at MPA-3.5 to 0.028 percent per minute at MPB-3.5. At MPB-3.5, oxygen dropped from 20.7 percent to 1.0 percent in 1,050 minutes.

Based on these oxygen utilization rates, an estimated 690 to 1,670 mg of fuel per kg of soil can be degraded each year at this site. This conservative estimate is based on an average air-filled porosity of approximately 0.030 liter per kg of soil, and a ratio of 3.5 mg of oxygen consumed for every 1 mg of fuel biodegraded. Actual rates may exceed these estimates and would be expected to increase as soil moisture levels decrease allowing more uniform oxygen distribution.

**TABLE 3.6**  
**MAXIMUM PRESSURE RESPONSE**  
**AIR PERMEABILITY TEST**  
**PS-4, BULK POL STORAGE AREA**  
**MALMSTROM AFB, MONTANA**

	Distance from vent well (VW) (feet)		
	5 (MPA)	15 (MPB)	28 (MPC)
Depth (feet)	3.5	3.5	3.5
Time (minutes)	95	95	95
Max Press. <sup>a/</sup> (inches H <sub>2</sub> O)	13.80	10.25	3.70

<sup>a/</sup> Maximum pressure.

**TABLE 3.7**  
**INFLUENCE OF AIR INJECTION AT VENT WELL**  
**ON MONITORING POINT OXYGEN LEVELS**  
**PS-4, BULK POL STORAGE AREA**  
**MALMSTROM AFB, MONTANA**

MP	Distance From VW (feet)	Depth(feet)	Initial O <sub>2</sub> (%)	Final O <sub>2</sub> (%) Permeability Test <sup>a/</sup>
A	5	3.5	0.0	10.1
B	15	3.5	0.0	10.6
C	28	3.5	0.0	7.7

<sup>a/</sup> Reading taken at end of 14.3-hour air permeability test.

Figure 3.4  
 Respiration Test  
 Oxygen Concentrations  
 Bulk POL Storage Yard, MPA-3.5  
 Malmstrom AFB, Montana

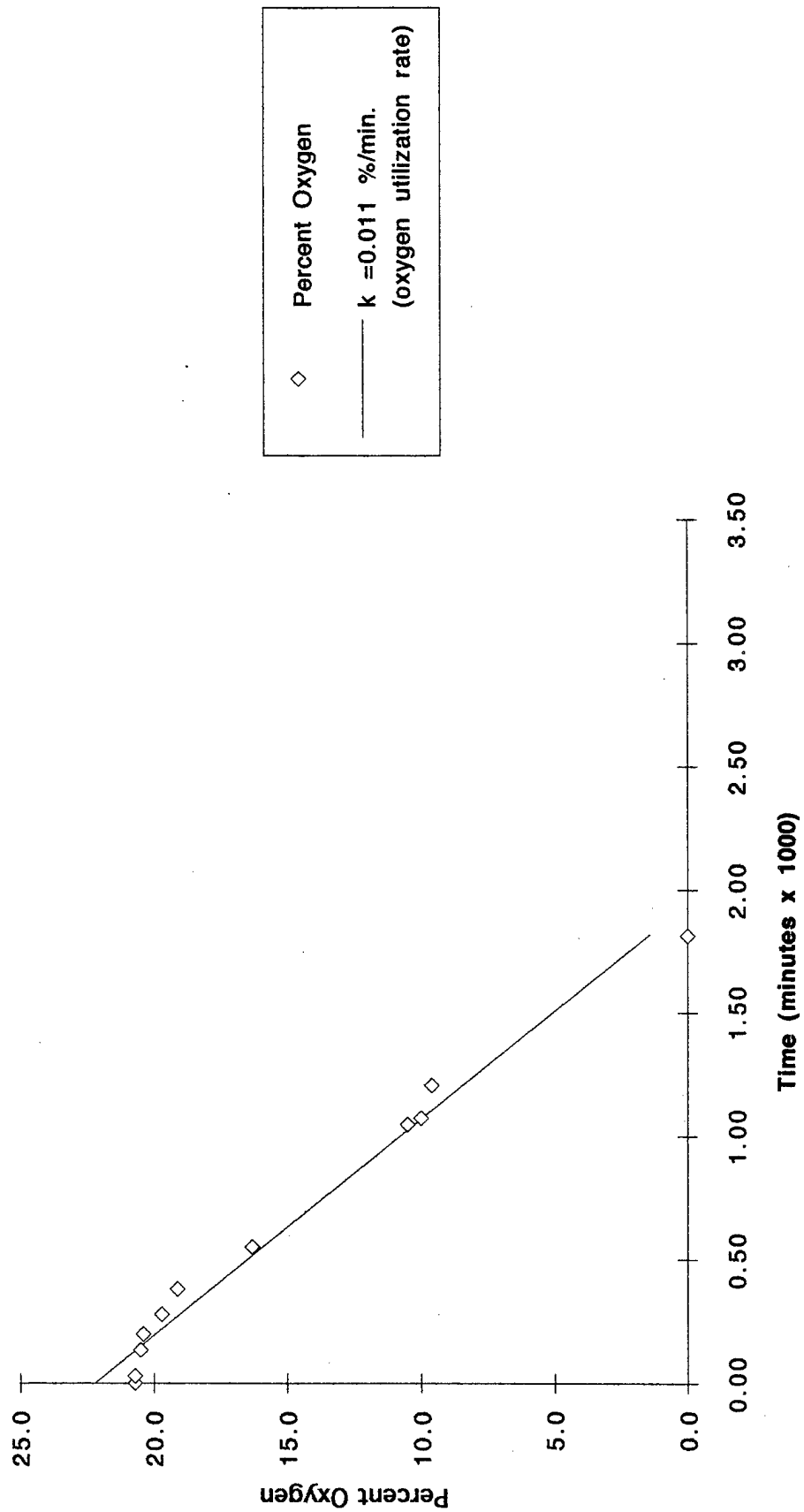

Figure 3.5  
 Respiration Test  
 Oxygen Concentrations  
 Bulk POL Storage Yard, MPB-3.5  
 Malmstrom AFB, Montana

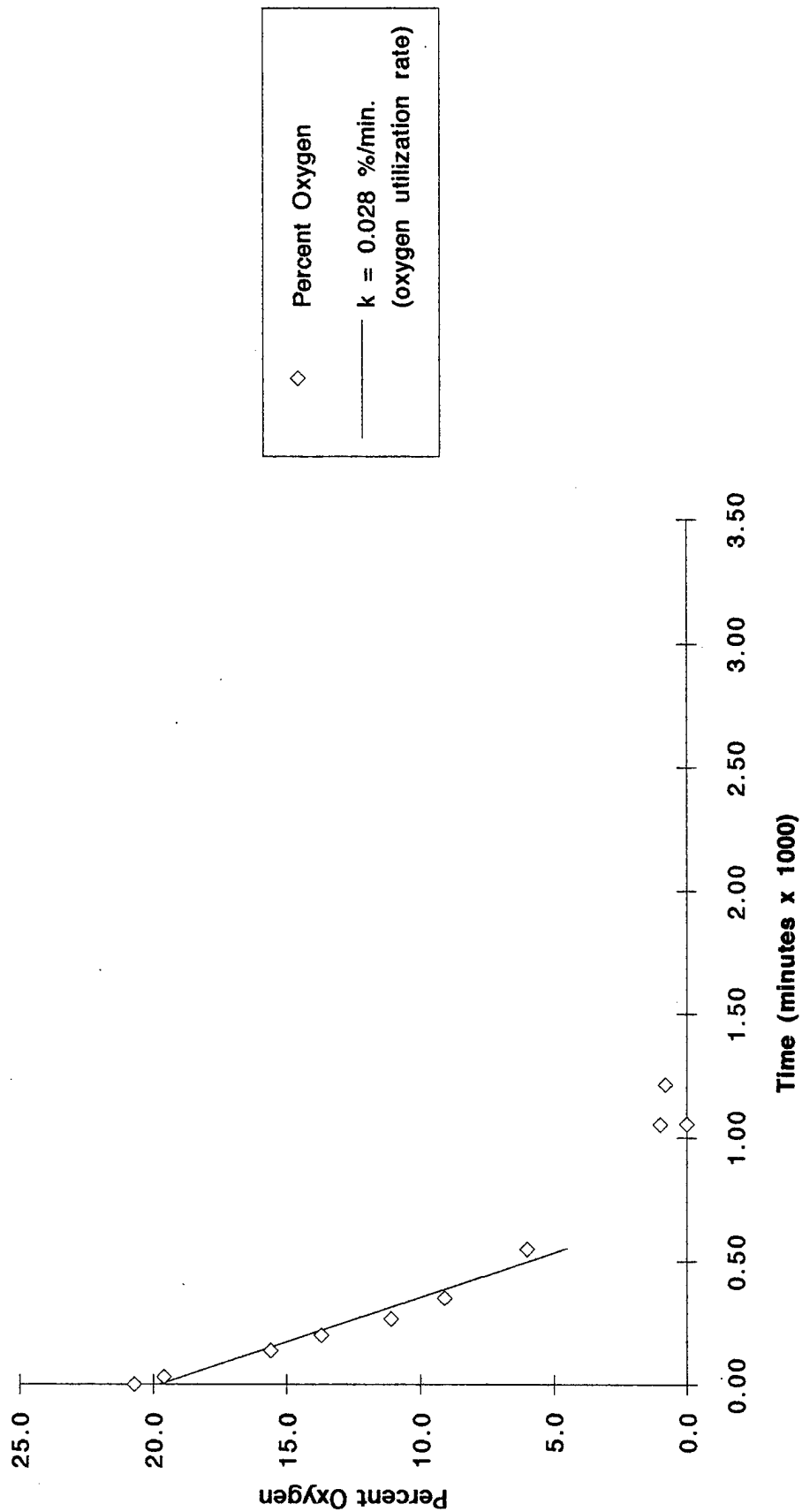
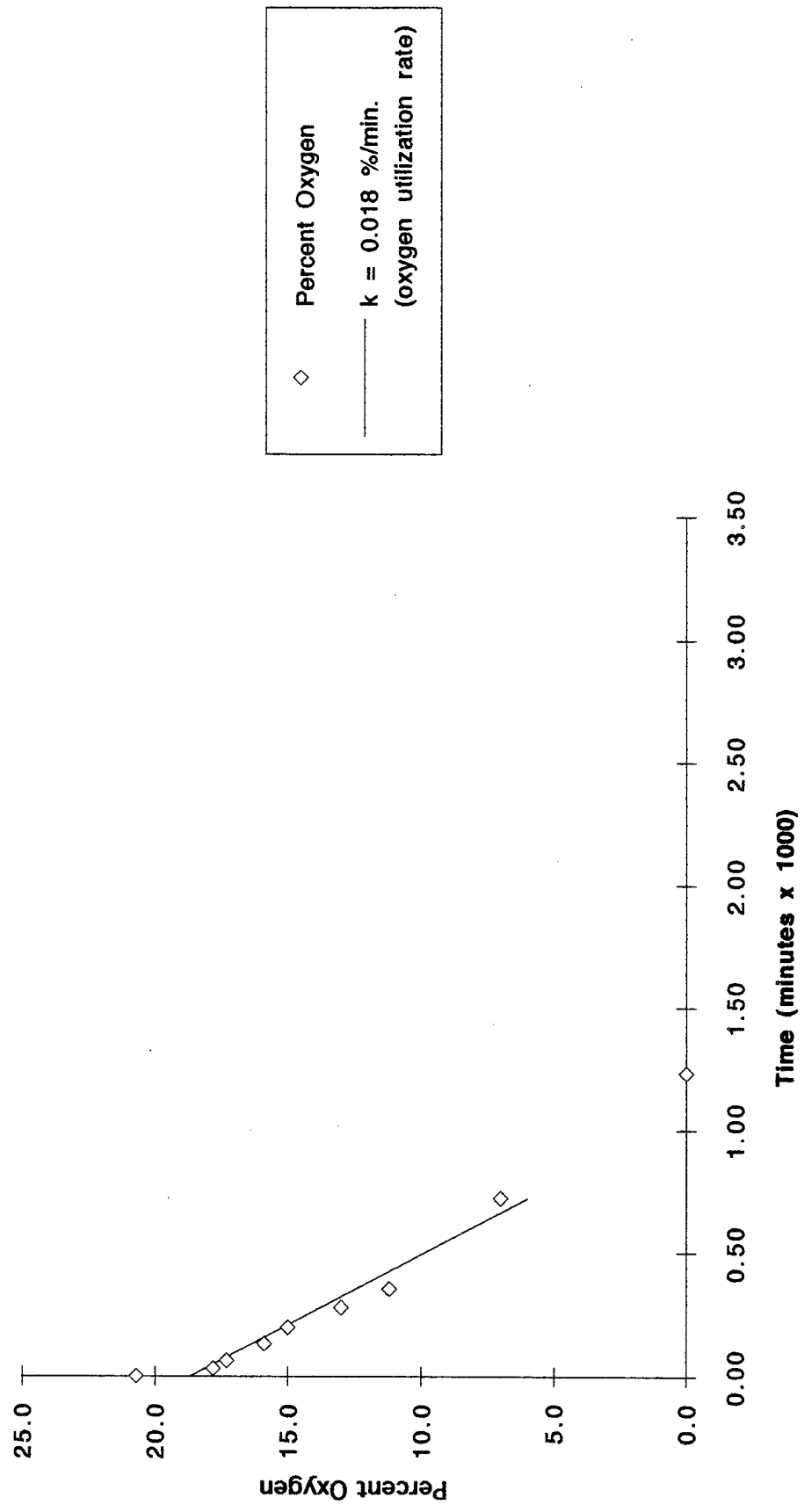

Figure 3.6  
 Respiration Test  
 Oxygen Concentrations  
 Bulk POL Storage Yard, MPC-3.5  
 Malmstrom AFB, Montana



**TABLE 3.8**  
**OXYGEN UTILIZATION RATES**  
**PS-4, BULK POL STORAGE AREA**  
**MALMSTROM AFB, MONTANA**

Location	O <sub>2</sub> Loss <sup>a/</sup> (Percent)	Test <sup>b/</sup> Duration (minutes)	O <sub>2</sub> Utilization <sup>c/</sup> Rate (Percent/minute)
MPA-3.5	20.7	1,820	0.011
MPB-3.5	14.7	550	0.028
MPC-3.5	13.7	720	0.018

a/ Actual measured oxygen loss.

b/ Elapsed time from beginning of test to time when minimum oxygen concentration was measured.

c/ Values based on best fit lines (Figures 3.4 through 3.6).

### 3.2.5 Potential Air Emissions

The long-term potential for air emissions from full-scale bioventing operations at this site is moderate because of the relatively permeable silty- and clayey-sandy soil and the shallow injection depth. The injection rate for the pilot test was set at approximately 18 scfm so that emissions would be minimal. Additionally, accumulated vapors will move slowly outward from the air injection VW, and vapor-phase hydrocarbons will be biodegraded as they move horizontally through the soil.

## 4.0 RECOMMENDATIONS

### 4.1 PS-3, Pumphouse 2

Initial bioventing tests at this site indicate that oxygen has been depleted in the contaminated soils, and that air injection is an effective method of increasing aerobic fuel biodegradation. AFCEE has recommended that air injection continue at this site to determine the long-term radius of oxygen influence and the effect of time, available nutrients, and changing temperatures on fuel biodegradation rates.

A small, 1-horsepower rotary-vane blower has been installed at the site to continue air injection at a rate of approximately 10 scfm. The electrical work was completed and the blower system was started the week of October 3, 1993. In March 1993, ES will return to the site to sample and analyze the soil gas and conduct a repeat respiration test. In October 1994, a final respiration test will be conducted, and soil and soil gas samples will be collected from the site to determine the degree of remediation achieved during the first year of *in situ* treatment.

Based on the results of the first year of pilot-scale bioventing, AFCEE will recommend one of three options:

- Upgrade, if necessary, and continue operation of the bioventing system for full-scale remediation of the site. AFCEE can assist the Base in obtaining regulatory approval for upgrading and continued operation; or
- If final soil sampling indicates significant contaminant removal has occurred, AFCEE may recommend additional sampling to confirm that cleanup criteria have been achieved; or
- If significant difficulties or poor results are encountered during bioventing at this site, AFCEE may recommend removal of the blower system and proper abandonment of the VW and MPs.

### 4.2 PS-4, Bulk POL Storage Area

Initial bioventing tests at this site indicate that oxygen has been depleted in the contaminated soils, and that air injection is an effective method of increasing aerobic fuel biodegradation. AFCEE has recommended that air injection continue at this site to determine the long-term radius of oxygen influence and the effect of time, available nutrients, and changing temperatures on fuel biodegradation rates.

A small, 1-horsepower regenerative blower has been installed at the site to continue air injection at a rate of approximately 18 scfm. The electrical work was completed and the blower system started the week of October 24, 1993. In March 1994, ES will return to the site to sample and analyze the soil gas and conduct a repeat respiration test. In October

1994, a final respiration test will be conducted, and soil and soil gas samples will be collected from the site to determine the degree of remediation achieved during the first year of *in situ* treatment.

Based on the results of the first year of pilot-scale bioventing, AFCEE will recommend one of three options:

- Upgrade, if necessary, and continue operation of the bioventing system for full-scale remediation of the site. AFCEE can assist the Base in obtaining regulatory approval for upgrading and continued operation; or
- If final soil sampling indicates significant contaminant removal has occurred, AFCEE may recommend additional sampling to confirm that cleanup criteria have been achieved; or
- If significant difficulties or poor results are encountered during bioventing at this site, AFCEE may recommend removal of the blower system and proper abandonment of the VW and MPs.

## 5.0 REFERENCES

Hinchee, R.E., S.K. Ong., R.N. Miller, D.C. Downey, and R. Frandt. 1992. *Test Plan and Technical Protocol for a Field Treatability Test for Bioventing*. Prepared for USAF Center for Environmental Excellence. May.

**APPENDIX A  
GEOLOGIC BORING LOGS,  
CHAIN-OF-CUSTODY FORMS,  
TEST DATA, AND CALCULATIONS**

# Stratigraphy Log



Project: Malmstrom AFB RCRA Investigation		Driller: O'Keefe Environmental Drilling		Geologist: E. Holt		Page 1 of 1			
HDR Project No.: 02285-039-134-01		Method: 4 1/4 hollow-stem auger		Boring I.D.: PS3-SB17		Date: 7/26/93			
Client: USACE Omaha District		Weather:		Well I.D.:		USAF CODE: IRP-ST04-SB17			
Depth (feet) bgs	Formation:	Stratigraphy	SS	N	N	N	N	OVA (ppm)	Comments
4	6	CL(CLAY) little fine sand, soft, moist to wet, grey-tan, dark mottling	A	4	6	7	7		
			24						
9	11	CL (CLAY) little-trace sand, errant gravel <3mm, uniform, firm, moist, tan-dark brown trace orange (rust) splotching	B	4	4	7	11		
			13						
14	16	CL (CLAY) little sand, some gravel <5mm sub-round, uniform, firm, moist, tan-dark brown grey-tan mottling	C	4	7	12	15		
			24						
19	21	CL (CLAY) little to trace sand, trace-little gravel <1cm round to <3cm subround, firm to hard, moist, tan-dark brown, grey-orange mottling	D	5	12	18	23		
			24						
									End of Boring

N - Blows per 6-inch interval  
 OVA - Organic Vapor Analyzer  
 Depth of measurement may be listed under Comments when applicable

ppm - parts per million  
 wt - Weight of Rod  
 SS - Split spoon sample identification

R - Split spoon recovery in inches  
 bgs - below ground surface.  
 /4 - 0.4 feet over 50 blow counts

Well No.: Bioivent Pumphouse #2  
 Boring No.: PS3-SB-17  
 Project No.: 02285-039-134  
 Prepared By.: J. Holt  
 Checked By: B. Sigler  
 Date Installed: 8-15-93

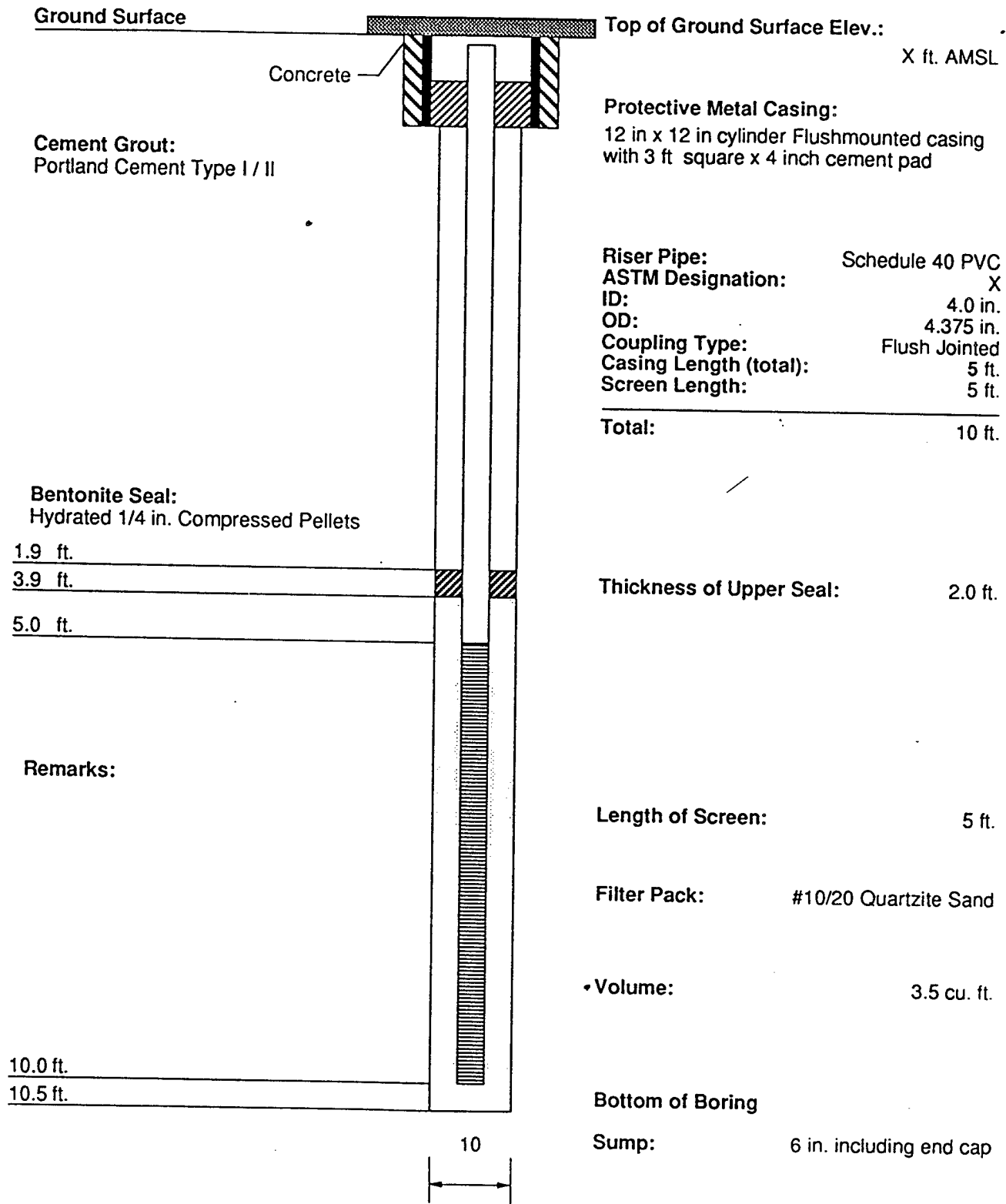

**Bentonite Seal:**  
 Hydrated 1/4 in. Compressed Pellets  
 1.9 ft.  
 3.9 ft.  
 5.0 ft.

**Protective Metal Casing:**  
 12 in x 12 in cylinder Flushmounted casing  
 with 3 ft square x 4 inch cement pad

**Riser Pipe:** Schedule 40 PVC  
**ASTM Designation:** X  
**ID:** 4.0 in.  
**OD:** 4.375 in.  
**Coupling Type:** Flush Jointed  
**Casing Length (total):** 5 ft.  
**Screen Length:** 5 ft.  
**Total:** 10 ft.

**Thickness of Upper Seal:** 2.0 ft.

**Length of Screen:** 5 ft.

**Filter Pack:** #10/20 Quartzite Sand

**Volume:** 3.5 cu. ft.

**Bottom of Boring**

**Sump:** 6 in. including end cap

**Remarks:**

10.0 ft.  
 10.5 ft.



**PS-3 Pumphouse #2, Bioivent Well Installation Diagram**



RCRA FACILITY INVESTIGATIONS  
 Malmstrom AFB, Montana  
 USACE Contract DACA45-92-C-0139  
 HDR Project 02285-035-134

Date	Nov. 1993
Figure	

7/93 File Bioivent #2 Projects/Malmstrom/Straigraphy Logs/Well Installation

RAF/DBT

9/30/93

DEZ68.38.04

RAF/DBT

9

After shopping  
all's free  
then that  
drill up till

PHZ-MPA

GS

neg depth

GRAVEL 1"-1 1/2" w/ some

CLAY

1'

SAA

CLAY w/ sm gravel, color

2' 760ppm

CLAY w/ fine sand lenses

SAA

3' 220

v. moist SAA - increasing H<sub>2</sub>O - 4' 280

SAA - low sand, v plastic + moist - 5' 250

∇

Saturated sand lenses + CLAY

SAA - definitely below gw - 6' 112

7'

poor sample recovery

8'

TID

9'

10'

plumbing  
magnet cursors  
shovel  
lost coin  
to 2 feet  
to book,  
cuttings  
Soil of  
staring and  
2.5' w/ clay  
may be difficult  
to take sample  
at MPA  
at MPA  
at MPA  
Cleanup

BTUC

RAF/DBT

10/3/93 DEZ68.38.04 RAF/DBT

go in it

1' and 6.5'

see

PHZ-MPB

GS

H.S

GRAVEL w/ 5m CLAY

CLAY w/ SAND SEAMS

-1

SAR - STRONG BOP sm

-2

black staining

increasing moisture w/ depth

-3

CLAY is very stiff

2,000

SAA

-4

$\frac{\Delta}{\text{min}}$

-5

-6

-7

SAA

TD = 8'

-8

site at MPA

will MRB,

PA.

" and sample

get deep point

7' bgs in MRB.

stop by.

re will try

to

to

quite chips and

Don Deff

up.

10/2/93 DE268.38.02 RAF/DBT

PHZ MPC

G.S. \_\_\_\_\_

H.S.

GRAVEL Soil w/ CLAY

CLAY w/ SAND seams

stiff dry, increasing resistive w depth



SAA, less sand

CLAY is stiff - dominates 4000 ppm  
other MPS



SAA

stratified CLAYS and SANDS 6 1100 ppm



SAA

TDS = 8

213.38.02 RAF/DBT

MPS, install all

seams for concrete

look up to end

mont land fence

for day





Well No.: Bioivent Bulk POL  
 Boring No.: PS4-SB04  
 Project No.: 02285-039-134  
 Prepared By.: J. Holt  
 Checked By: B. Sigler  
 Date Installed: 8-15-93

Ground Surface

Top of Ground Surface Elev.:

X ft. AMSL

Concrete

Cement Grout:  
 Portland Cement Type I / II

Protective Metal Casing:

12 in x 12 in cylinder Flushmounted casing  
 with 3 ft square x 4 inch cement pad

Riser Pipe:

Schedule 40 PVC

ASTM Designation:

X

ID:

4.0 in.

OD:

4.375 in.

Coupling Type:

Flush Jointed

Casing Length (total):

5 ft.

Screen Length:

5 ft.

Total:

10 ft.

Bentonite Seal:

Hydrated 1/4 in. Compressed Pellets

1.7 ft.

3.9 ft.

5.0 ft.

Thickness of Upper Seal:

2.2 ft.

Remarks:

Length of Screen:

5 ft.

Filter Pack:

#10/20 Quartzite Sand

Volume:

4.0 cu. ft.

10.0 ft.

10.5 ft.

Bottom of Boring

Sump:

6 in. including end cap

10

**HDR**

HDR Engineering, Inc.

**PS-4 Bulk POL, Bioivent  
 Well Installation Diagram**



RCRA FACILITY INVESTIGATIONS  
 Malmstrom AFB, Montana  
 USACE Contract DACA45-92-C-0139  
 HDR Project 02285-035-134

Date

Nov. 1993

Figure

36

10/10/93 RA DEZ68.38.02 RAF/DST

PCC Storage: MPA

GS

HS

Sandy clay w/ gravel

some 1/2" gravel. Stained w/ odor 1 1900

grey to black some olive clay

clayey sand with little gravel. 2 7600

Stained w/ odor.

Sl. moist Coarsely sand with some clay 3 9200

1/2-1" size gravel. Stained w/ odor

∇ SAA less clay with depth increasing DE 1800

≡ Fine sand, saturated, grey to black strong odor

SAA some grey clay 5 210,000

lenses

SAA very saturated 6 6800

very strong odor

SAA 7 4200

↓

TD ≈ 8'

8

10/10/93 DEZ68.38

1525 Resume drilling

3' and see how far it

1545 Get hole to stay

build MPA 7.5'

1551 Fire Dept leaves

1709 Finish building

cleaning up

1715 Call Pot hole

1725 Check on blower

get ~~blower~~ off site

relief valve to hole

w/ it tomorrow

1730 Hook PAZ and 1.

Russ

RAF/DBT

10/11/98

DE 268.38.04

RAF/DBT<sup>39</sup>

POL Yard: MAB Being log

G.S.

H.S.

GRAVEL 1" to 2" well rounded - 1  
w/ sm CLAY + SILT

SAA

Fire sand w/ some CLAY SAMPLES  
strong odor, moist dirt/gray to  
black, increasing moisture w/  
depth

SAA

- 2  
- 4  
- 5  
- 6,800  
- 76,200  
- 85,000

drill MPB

begin

less augers

leaves the

2 = Ø for 30 sec

and 3.5'

again during

over site

for phone

the stepping

site 9/50.

3.5' bgs

calling

site











**AIR TOXICS LTD.**  
AN ENVIRONMENTAL ANALYTICAL LABORATORY

180 BLUE RAVINE ROAD, SUITE B  
FOLSOM, CA 95630  
(916) 985-1000 • FAX (916) 985-1020

## CHAIN OF CUSTODY RECORD

Page 1 of 1

PROJECT # DEZ68.38.04 PO # DEZ68.38.09 COLLECTED BY (Signature) [Signature]  
REMARKS \_\_\_\_\_

FIELD SAMPLE I.D.#	SAMPLING MEDIA (Tenax, Canister etc.)	DATE/TIME	ANALYSIS	VAC./PRESSURE	LAB I.D. #
MSI-MPA-4	CANISTER	10/3/93 1040	T0-3 (STEX & TPH)	5.04g	
MSI-MPB-4	"	10/3/93 1110	"	8.04g	
MSI-MPC-4	"	10/3/93 1140	"	3.54g	

01A/B  
02A  
03A

RELINQUISHED BY: DATE/TIME RUSSELL FRISHMUTH 10/4/93 1200 RECEIVED BY: DATE/TIME [Signature] 10-5-93 10:03  
RELINQUISHED BY: DATE/TIME \_\_\_\_\_ RECEIVED BY: DATE/TIME \_\_\_\_\_

### LAB USE ONLY

SHIPPER NAME \_\_\_\_\_ AIR BILL # \_\_\_\_\_ OPENED BY: DATE/TIME \_\_\_\_\_ TEMP (°C) \_\_\_\_\_  
CONDITION \_\_\_\_\_

REMARKS \_\_\_\_\_  
\_\_\_\_\_



**AIR TOXICS LTD.**  
AN ENVIRONMENTAL ANALYTICAL LABORATORY

180 BLUE RAVINE ROAD, SUITE B  
FOLSOM, CA 95630  
(916) 985-1000 • FAX (916) 985-1020

## CHAIN OF CUSTODY RECORD

Page 1 of 1

PROJECT # DE268,38.04 PO # DE268,38.09 COLLECTED BY (Signature) David Tate  
REMARKS \_\_\_\_\_

FIELD SAMPLE I.D.#	SAMPLING MEDIA (Tenax, Canister etc.)	DATE/TIME	ANALYSIS	VAC./PRESSURE	LAB I.D.#
M52-MPA-3.5	Canister	10/12/93 1613	TO-3 (BTEX + TPH)		
M52-MPB-3.5	"	10/12/93 1557	"		
M52-MPC-3.5	"	10/12/93 1535	"		

RELINQUISHED BY: DATE/TIME David Teets 10/12/93/1800 RECEIVED BY: DATE/TIME FED EX 10/13/93 1800  
RELINQUISHED BY: DATE/TIME \_\_\_\_\_ RECEIVED BY: DATE/TIME \_\_\_\_\_

**LAB USE ONLY**

SHIPPER NAME \_\_\_\_\_ AIR BILL # \_\_\_\_\_ OPENED BY: DATE/TIME \_\_\_\_\_ TEMP (°C) \_\_\_\_\_  
CONDITION \_\_\_\_\_

REMARKS \_\_\_\_\_

Respiration Test												
Pumphouse 2												
Malmstrom AFB, MT												
Monitoring Point	Date	Days Elapsed (frac. days)	Days Elapsed (min. x 1000)	Hrs elapsed (fractional days)	Days Elapsed	O2% (min. x 1000)	CO2% (min. x 1000)	Total Hydro-carbon	Helium	Comments	Trend of O2/ Time	New x-values k
MPA-4	10/04/93	0.00	11:00	0.00	0.00	20.0	0.10	700 NS		30 second purge. Sample collected by egg.	17.8130666	0
MPA-4	10/04/93	0.00	11:53	0.04	0.04	15.2	0.25	2000 NS		30 second purge. Sample collected by egg.	1.74411648	0.33
MPA-4	10/04/93	0.00	12:23	0.06	0.06	12.9	0.30	2400 NS		30 second purge. Sample collected by egg.		
MPA-4	10/04/93	0.00	12:34	0.07	0.07	12.9	0.30	2800 NS		30 second purge. Sample collected by egg.		
MPA-4	10/04/93	0.00	12:52	0.08	0.08	11.6	0.25	2600 NS		30 second purge. Sample collected by egg.		
MPA-4	10/04/93	0.00	13:27	0.10	0.10	9.4	0.55	3100 NS		30 second purge. Sample collected by egg.		
MPA-4	10/04/93	0.00	14:19	0.14	0.14	7.8	0.60	3400 NS		30 second purge. Sample collected by egg.		
MPA-4	10/04/93	0.00	15:33	0.19	0.19	4.8	0.6	4100 NS		30 second purge. Sample collected by egg.		
MPA-4	10/04/93	0.00	16:27	0.23	0.23	3.0	0.7	4800 NS		30 second purge. Sample collected by egg.		
MPA-4	10/05/93	1.00	09:21	-0.07	0.93	1.34	0.2	9	11200 NS	30 second purge. Sample collected by egg.		
MPB-4	10/04/93	0.00	10:44	0.00	0.00	20.2	0.07	320 NS		1 minute purge. Sample collected by egg.	19.4543939	0
MPB-4	10/04/93	0.00	11:44	0.04	0.04	17.2	0.10	940 NS		1 minute purge. Sample collected by egg.	3.65835359	0.34
MPB-4	10/04/93	0.00	12:18	0.07	0.07	14.8	0.10	1200 NS		1 minute purge. Sample collected by egg.		
MPB-4	10/04/93	0.00	12:50	0.09	0.09	13.0	0.10	1800 NS		1 minute purge. Sample collected by egg.		
MPB-4	10/04/93	0.00	13:24	0.11	0.11	11.2	0.10	2000 NS		1 minute purge. Sample collected by egg.		
MPB-4	10/04/93	0.00	14:13	0.15	0.15	9.4	0.10	2300 NS		1 minute purge. Sample collected by egg.		
MPB-4	10/04/93	0.00	15:31	0.20	0.20	5.9	0.10	3200 NS		1 minute purge. Sample collected by egg.		
MPB-4	10/04/93	0.00	16:23	0.24	0.24	4.7	0.10	3600 NS		1 minute purge. Sample collected by egg.		
MPB-4	10/05/93	1.00	09:15	-0.05	0.94	1.35	0.3	0.10	8000 NS	1 minute purge. Sample collected by egg.		
MPC-4	10/04/93	0.00	10:51	0.00	0.00	20.5	0.15	540 NS		25 second purge. Sample collected by egg.	18.4648913	0
MPC-4	10/04/93	0.00	11:51	0.04	0.04	15.1	0.40	2700 NS		25 second purge. Sample collected by egg.	-0.53371564	0.33
MPC-4	10/04/93	0.00	12:15	0.06	0.06	11.9	0.40	3800 NS		25 second purge. Sample collected by egg.		
MPC-4	10/04/93	0.00	12:47	0.08	0.08	10.6	0.40	4000 NS		25 second purge. Sample collected by egg.		
MPC-4	10/04/93	0.00	13:22	0.10	0.10	10.5	0.60	3700 NS		25 second purge. Sample collected by egg.		
MPC-4	10/04/93	0.00	14:08	0.14	0.14	6.1	0.60	5100 NS		25 second purge. Sample collected by egg.		
MPC-4	10/04/93	0.00	15:27	0.19	0.19	2.3	0.70	6600 NS		25 second purge. Sample collected by egg.		
MPC-4	10/04/93	0.00	16:18	0.23	0.23	1.0	0.70	8000 NS		Hydrocarbon analyzer with diluter.		
MPC-4	10/05/93	1.00	09:30	-0.05	0.95	1.38	0.0	1.40	19000 NS	Hydrocarbon analyzer with diluter.		

Monitoring Point	Date	Days Elapsed (frac. days)	Time	Hrs elapsed (fractional days)	Days Elapsed	Respiration Test				Helium	Comments	Trend of O2/ Time	New x-values
						Elapsed Time (min. x 1000)	O2%	CO2%	Total Hydro-carbon				
MPA-3.5	10/13/93	0.00	13:30	0.00	0.00	0.00	20.7	0.05	96	0 1 minute purge	22.2058742	0	0.01142
MPA-3.5	10/13/93	0.00	14:00	0.02	0.02	0.03	20.7	0.05	64	0.01 1 minute purge	1.42164311	1.82	
MPA-3.5	10/13/93	0.00	15:45	0.09	0.09	0.14	20.5	0.05	140	0 1 minute purge			
MPA-3.5	10/13/93	0.00	16:50	0.14	0.14	0.20	20.4	0.07	180	0 1 minute purge			
MPA-3.5	10/13/93	0.00	18:10	0.19	0.19	0.28	19.7	0.6	440	0 Purged and sampled with meters			
MPA-3.5	10/13/93	0.00	19:52	0.27	0.27	0.38	19.1	0.05	680	0 Purged and sampled with meters			
MPA-3.5	10/13/93	0.00	22:42	0.38	0.38	0.55	16.3	0.09	1700	0 New meter			
MPA-3.5	10/14/93	1.00	6:58	-0.27	0.73	1.05	10.5	0.95	3800	NS Purged and sampled with meters			
MPA-3.5	10/14/93	1.00	7:23	-0.25	0.75	1.07	10.0	1.5	NS	NS O2/CO2 meter acting strange			
MPA-3.5	10/14/93	1.00	9:36	-0.16	0.84	1.21	9.6	1.1	4600	NS 1 minute purge			
MPA-3.5	10/14/93	1.00	17:12	0.26	1.26	1.82	0.0	2.90	8000	NS Sample at MP top directly			
MPB-3.5	10/13/93	0.00	13:35	0.00	0.00	0.00	20.7	0.05	705	0 1 minute purge	19.7530434	0	0.02772
MPB-3.5	10/13/93	0.00	14:05	0.02	0.02	0.03	19.6	0.05	1700	0 1 minute purge	4.50551263	0.55	
MPB-3.5	10/13/93	0.00	15:53	0.10	0.10	0.14	15.6	0.07	3300	0 1 minute purge			
MPB-3.5	10/13/93	0.00	16:55	0.14	0.14	0.20	13.7	0.09	3800	0 1 minute purge			
MPB-3.5	10/13/93	0.00	18:00	0.18	0.18	0.27	11.1	0.70	5300	0 Purged and sampled with meters			
MPB-3.5	10/13/93	0.00	19:25	0.24	0.24	0.35	9.1	0.05	5900	0 Purged and sampled with meters			
MPB-3.5	10/13/93	0.00	22:44	0.38	0.38	0.55	6.0	0.10	7300	0 New O2/CO2 meter			
MPB-3.5	10/14/93	1.00	07:06	-0.27	0.73	1.05	1.0	0.5	2000	NS 1 minute purge			
MPB-3.5	10/14/93	1.00	07:10	-0.27	0.73	1.06	0.0	0.5	2500	NS Resample			
MPB-3.5	10/14/93	1.00	09:50	-0.16	0.84	1.22	0.8	0.1	10600	NS 1 minute purge			
MPC-3.5	10/13/93	0.00	13:41	0.00	0.00	0.00	20.7	0.05	140	0 0 1 minute purge	18.6643372	0	0.01759
MPC-3.5	10/13/93	0.00	14:14	0.02	0.02	0.03	17.8	0.05	2700	0 0 90 second purge, purge monitored	5.99995743	0.72	
MPC-3.5	10/13/93	0.00	14:45	0.04	0.04	0.06	17.3	0.05	3100	0 13 90 second purge, purge monitored			
MPC-3.5	10/13/93	0.00	15:55	0.09	0.09	0.13	15.9	0.06	4300	0 15 90 second purge			
MPC-3.5	10/13/93	0.00	17:00	0.14	0.14	0.20	15.0	0.09	4900	NS 90 second purge			
MPC-3.5	10/13/93	0.00	18:20	0.19	0.19	0.28	13.0	0.40	5800	NS 90 second purge			
MPC-3.5	10/13/93	0.00	19:35	0.25	0.25	0.35	11.2	0.05	6800	NS 90 second purge			
MPC-3.5	10/13/93	0.00	22:46	0.50	0.50	0.72	7.0	0.07	8600	NS 90 second purge			
MPC-3.5	10/14/93	1.00	07:15	-0.14	0.86	1.23	0.0	0.08	4100	NS Meters acting very strange			

### Air Permeability Test - Data Analysis (cont.)

Enter radial distances of monitoring points → r =  (ft)      r =  (ft)      r =  (ft)

Enter measured times and gauge vacuums →

Enter (optional):

a) flowrate  (SCFM)

b) screened interval thickness  (ft)

(min)	(in H <sub>2</sub> O)	(min)	(in H <sub>2</sub> O)	(min)	(in H <sub>2</sub> O)
0	0.5	0	0.48	0	0.18
1	1	1	0.49	1	0.18
2	2.2	2	0.98	2	0.24
3	3.5	3	1.6	3	0.35
4	5.3	4	2.55	4	0.52
5	7.25	5	3.85	5	0.8
6	8.6	6	4.8	6	10.7
7	9.5	7	5.6	7	1.4
8	10	8	6.2	8	1.57
9	10.5	9	6.6	9	1.75

clear      clear      clear

→ Calculate ←

k= <input type="text" value="8.28527"/> darcy (A)	k= <input type="text" value="10.7348"/> darcy (A)	k= <input type="text" value="36.4265"/> darcy (A)
k= <input type="text" value="1.66338"/> darcy (B)	k= <input type="text" value="9.16863"/> darcy (B)	k= <input type="text" value="56.6657"/> darcy (B)



Return



Explanation & Statistics

AP8

## Air Permeability Test - Data Analysis (cont.)

Enter radial distances of monitoring points → r=  (ft)      r=  (ft)      r=  (ft)

Enter measured times and gauge vacuums →

Enter (optional):

a) flowrate  (SCFM)

b) screened interval thickness  (ft)

	(min)	(in H2O)		(min)	(in H2O)		(min)	(in H2O)	
10	115	↑	1	0.5	↑	1	0.1	↑	
12	115	□	2	8	□	2	0.7	□	
14	107	▨	3	17.5	▨	3	2	▨	
16	107	▨	4	20	▨	4	3.25	▨	
18	107	▨	5	26	▨	5	4.4	▨	
20	107	▨	6	29	▨	6	5.0	▨	
25	107	▨	7	30	▨	7	5.8	▨	
30	105	▨	8	31	▨	8	6.1	▨	
45	105	▨	9	31	▨	9	6.4	▨	
60	102	↓	12	31.25	↓	12	6.6	↓	

clear      clear      clear

→ Calculate ←      k=  darcy (A)      k=  darcy (A)      k=  darcy (A)  
k=  darcy (B)      k=  darcy (B)      k=  darcy (B)



Return



Explanation & Statistics

AP8

Malmstrom AFB – Pumphouse 2  
Biodegradation Rate Calculations

enter data

calculated data

Formula:  $K_b = K_o \times 1/100\% \times A \times D_o \times C$  Where:

$K_b$  = fuel biodegradation rate

$K_o$  =  $O_2$  utilization rate (%/min.)

A = volume of air/kg soil

$D_o$  =  $O_2$  density = 1340 mg/L

C = Carbon/ $O_2$  ratio for hexane mineralization = 1/3.5

Test Results:

MPB-4

$K_o$  = max. observed rate

0.04646

%/min.

w = moisture content

22

%

Assume:

Soil properties for mixed grained sand Specify from  
Table 1.4 (Ref. Foundation Engineering, Peck, Hanson, and Thornburn,  
John Wiley Press, 1974)

Porosity:

$n = 0.4$

Unit weight (dry):

$\%d = 1.72$

Void ratio:

$e = n/(1-n) = 0.67$

Specific gravity:

G = 2.65

Calculate A = Air filled volume ( $V_a$ )/unit wt.

Solving for 1 liter of soil

a)  $V_v = n \times 1 \text{ L}$

$V_v = 0.4$  liters  $V_v$  = void volume

b)  $S_r = Gw/e$

$S_r = 0.87$   $S_r$  = degree of saturation

c)  $V_w = S_r \times V_v$

$V_w = 0.35$  liters  $V_w$  = volume of water

d)  $V_a = V_v - V_w$

$V_a = 0.05$  liters  $V_a$  = volume of air

e) Bulk density =  $\%d + (V_w \times \%w) = 2.1$  kg/l soil

f)  $A = V_a/\text{Bulk density} = 0.024$  l air/kg soil

$K_b = K_o \times 1/100\% \times A \times D_o \times C \times 525,600 \text{ min/yr} = 2240$  mg TPH/year

Malmstrom AFB – Pumpouse 2  
Biodegradation Rate Calculations

enter data

calculated data

Formula:  $K_b = K_o \times 1/100\% \times A \times D_o \times C$  Where:

$K_b$  = fuel biodegradation rate

$K_o$  =  $O_2$  utilization rate (%/min.)

A = volume of air/kg soil

$D_o$  =  $O_2$  density = 1340 mg/L

C = Carbon/ $O_2$  ratio for hexane mineralization = 1/3.5

Test Results: MPC-4  $K_o$  = max. observed rate 0.05757 %/min.  
w = moisture content 22 %

Assume: Soil properties for mixed grained sand Specify from  
Table 1.4 (Ref. Foundation Engineering, Peck, Hanson, and Thornburn,  
John Wiley Press, 1974)

Porosity:  $n = 0.4$   
Unit weight (dry):  $\%d = 1.72$   
Void ratio:  $e = n/(1-n) = 0.67$   
Specific gravity:  $G = 2.65$

Calculate A = Air filled volume ( $V_a$ )/unit wt.

Solving for 1 liter of soil

a)  $V_v = n \times 1 \text{ L}$   
 $V_v = 0.4$  liters  $V_v$  = void volume

b)  $S_r = Gw/e$   
 $S_r = 0.87$   $S_r$  = degree of saturation

c)  $V_w = S_r \times V_v$   
 $V_w = 0.35$  liters  $V_w$  = volume of water

d)  $V_a = V_v - V_w$   
 $V_a = 0.05$  liters  $V_a$  = volume of air

e) Bulk density =  $\%d + (V_w \times \%w) = 2.1$  kg/l soil

f)  $A = V_a/\text{Bulk density} = 0.024$  l air/kg soil

$K_b = K_o \times 1/100\% \times A \times D_o \times C \times 525,600 \text{ min/yr} = 2780$  mg TPH/year

Malmstrom AFB – Bulk POL Storage Area

Biodegradation Rate Calculations

enter data

calculated data

Formula:  $K_b = K_o \times 1/100\% \times A \times D_o \times C$  Where:

$K_b$  = fuel biodegradation rate

$K_o$  =  $O_2$  utilization rate (%/min.)

A = volume of air/kg soil

$D_o$  =  $O_2$  density = 1340 mg/L

C = Carbon/ $O_2$  ratio for hexane mineralization = 1/3.5

Test Results:

MPB – 3.5

$K_o$  = max. observed rate

0.02772

%/min.

w = moisture content

17

%

Assume:

Soil properties for mixed grained sand Specify from

Table 1.4 (Ref. Foundation Engineering, Peck, Hanson, and Thornburn, John Wiley Press, 1974)

Porosity:

$n = 0.35$

Unit weight (dry):

$\gamma_d = 1.72$

Void ratio:

$e = n/(1-n) = 0.54$

Specific gravity:

G = 2.65

Calculate A = Air filled volume ( $V_a$ )/unit wt.

Solving for 1 liter of soil

a)  $V_v = n \times 1 \text{ L}$

$V_v = 0.35$  liters

$V_v$  = void volume

b)  $S_r = Gw/e$

$S_r = 0.83$

$S_r$  = degree of saturation

c)  $V_w = S_r \times V_v$

$V_w = 0.29$  liters

$V_w$  = volume of water

d)  $V_a = V_v - V_w$

$V_a = 0.06$  liters

$V_a$  = volume of air

e) Bulk density =  $\gamma_d + (V_w \times \gamma_w) = 2$  kg/l soil

f)  $A = V_a/\text{Bulk density} = 0.03$  l air/kg soil

$K_b = K_o \times 1/100\% \times A \times D_o \times C \times 525,600 \text{ min/yr} = 1670$  mg TPH/year

Malmstrom AFB – Bulk POL Storage Area

Biodegradation Rate Calculations

enter data

calculated data

Formula:  $K_b = K_o \times 1/100\% \times A \times D_o \times C$  Where:

$K_b$  = fuel biodegradation rate

$K_o$  =  $O_2$  utilization rate (%/min.)

A = volume of air/kg soil

$D_o$  =  $O_2$  density = 1340 mg/L

C = Carbon/ $O_2$  ratio for hexane mineralization = 1/3.5

Test Results:

MPC-3.5

$K_o$  = max. observed rate

0.01142

%/min.

w = moisture content

17

%

Assume:

Soil properties for mixed grained sand Specify from Table 1.4 (Ref. Foundation Engineering, Peck, Hanson, and Thornburn, John Wiley Press, 1974)

Porosity:

$n = 0.35$

Unit weight (dry):

$\gamma_d = 1.72$

Void ratio:

$e = n/(1-n) = 0.54$

Specific gravity:

G = 2.65

Calculate A = Air filled volume ( $V_a$ )/unit wt.

Solving for 1 liter of soil

a)  $V_v = n \times 1 \text{ L}$

$V_v = 0.35$  liters  $V_v$  = void volume

b)  $S_r = Gw/e$

$S_r = 0.83$   $S_r$  = degree of saturation

c)  $V_w = S_r \times V_v$

$V_w = 0.29$  liters  $V_w$  = volume of water

d)  $V_a = V_v - V_w$

$V_a = 0.06$  liters  $V_a$  = volume of air

e) Bulk density =  $\gamma_d + (V_w \times \gamma_w) = 2$  kg/l soil

f)  $A = V_a/\text{Bulk density} = 0.03$  l air/kg soil

$K_b = K_o \times 1/100\% \times A \times D_o \times C \times 525,600 \text{ min/yr} = 690$  mg TPH/year

**APPENDIX B  
O&M CHECKLIST**

