

LOAN DOCUMENT

PHOTOGRAPH THIS SHEET

0

DTIC ACCESSION NUMBER

LEVEL

INVENTORY

work plan for a Treatability Study...

DOCUMENT IDENTIFICATION

Apr 95

DISTRIBUTION STATEMENT A
Approved for Public Release
Distribution Unlimited

DISTRIBUTION STATEMENT

ACCESSION FOR	
NTIS	GRAM
DTIC	TRAC
UNANNOUNCED	
JUSTIFICATION	
BY	
DISTRIBUTION/	
AVAILABILITY CODES	
DISTRIBUTION	AVAILABILITY AND/OR SPECIAL
A-1	

DISTRIBUTION STAMP

DATE ACCESSIONED

DATE RETURNED

DTIC QUALITY CONTROLLED 4

20010116 029

DATE RECEIVED IN DTIC

REGISTERED OR CERTIFIED NUMBER

PHOTOGRAPH THIS SHEET AND RETURN TO DTIC-FDAC

H
A
N
D
L
E

W
I
T
H

C
A
R
E

**Work Plan for a
Treatability Study in Support of the
Intrinsic Remediation (Natural Attenuation) Option at
The Current Fire Training Area (Site FT-08) and
The Christmas Tree Fire Training Area (Site FT-03)**



**Westover Air Reserve Base
Chicopee, Massachusetts**

Prepared For

**Air Force Center for Environmental Excellence
Brooks Air Force Base
San Antonio, Texas**

and

**439th SPTG/CEV
Westover Air Reserve Base
Chicopee, Massachusetts**

April 1995



**PARSONS
ENGINEERING SCIENCE, INC.**

1700 Broadway, Suite 900 • Denver, Colorado 80290

AQM01-04-0615

DEFENSE TECHNICAL INFORMATION CENTER
REQUEST FOR SCIENTIFIC AND TECHNICAL REPORTS

Title AFCEE Collection

1. Report Availability (Please check one box)

- This report is available. Complete sections 2a - 2f.
- This report is not available. Complete section 3.

2a. Number of Copies Forwarded

Leach

2b. Forwarding Date

July 2000

2c. Distribution Statement (Please check ONE box)

DoD Directive 5230.24, "Distribution Statements on Technical Documents," 18 Mar 87, contains seven distribution statements, as described briefly below. Technical documents MUST be assigned a distribution statement.

- DISTRIBUTION STATEMENT A: Approved for public release. Distribution is unlimited.
- DISTRIBUTION STATEMENT B: Distribution authorized to U.S. Government Agencies only.
- DISTRIBUTION STATEMENT C: Distribution authorized to U.S. Government Agencies and their contractors.
- DISTRIBUTION STATEMENT D: Distribution authorized to U.S. Department of Defense (DoD) and U.S. DoD contractors only.
- DISTRIBUTION STATEMENT E: Distribution authorized to U.S. Department of Defense (DoD) components only.
- DISTRIBUTION STATEMENT F: Further dissemination only as directed by the controlling DoD office indicated below or by higher authority.
- DISTRIBUTION STATEMENT X: Distribution authorized to U.S. Government agencies and private individuals or enterprises eligible to obtain export-controlled technical data in accordance with DoD Directive 5230.25, Withholding of Unclassified Technical Data from Public Disclosure, 6 Nov 84.

2d. Reason For the Above Distribution Statement (in accordance with DoD Directive 5230.24)

2e. Controlling Office

HQ AFCEE

2f. Date of Distribution Statement Determination

15 Nov 2000

3. This report is NOT forwarded for the following reasons. (Please check appropriate box)

- It was previously forwarded to DTIC on _____ (date) and the AD number is _____
- It will be published at a later date. Enter approximate date if known. _____
- In accordance with the provisions of DoD Directive 3200.12, the requested document is not supplied because:

Print or Type Name

Laura Peña

Telephone

210-536-1431

Signature

Laura Peña

(For DTIC only)

AD Number

M01-04-0615

WORK PLAN FOR A TREATABILITY STUDY
IN SUPPORT OF THE INTRINSIC REMEDIATION
(NATURAL ATTENUATION) OPTION FOR THE
CURRENT FIRE TRAINING AREA (FT-08) AND THE
CHRISTMAS TREE FIRE TRAINING AREA (FT-03)

at

WESTOVER AIR RESERVE BASE
CHICOPEE, MASSACHUSETTS

April 1995

Prepared for:

AIR FORCE CENTER FOR ENVIRONMENTAL EXCELLENCE
BROOKS AIR FORCE BASE
SAN ANTONIO, TEXAS

AND

439th SPTG/CEV
WESTOVER AIR RESERVE BASE
CHICOPEE, MASSACHUSETTS

Prepared by:

Parsons Engineering Science, Inc.
1700 Broadway, Suite 900
Denver, Colorado 80290

TABLE OF CONTENTS

	<u>Page</u>
1 Introduction	1-1
1.1 Scope of Current Work Plan	1-2
1.2 Background.....	1-3
1.2.1 Current Fire Training Area	1-3
1.2.2 Christmas Tree Fire Training Area.....	1-6
2 Data Review and Conceptual Model Development	2-1
2.1 Data Review	2-1
2.1.1 Topography, Surface Hydrology, and Climate	2-1
2.1.2 Overview of Geology and Hydrogeology.....	2-2
2.1.2.1 Regional Geology and Hydrogeology	2-2
2.1.2.2 FT-08 Geology and Hydrogeology	2-6
2.1.2.3 Site FT-03 Site Geology and Hydrogeology	2-13
2.1.3 Summary of Analytical Results at Site FT-08	2-13
2.1.3.1 Soil Gas Survey	2-13
2.1.3.2 Soil Sampling	2-21
2.1.3.3 Groundwater Sampling.....	2-21
2.1.3.4 Electrical Resistivity Surveys	2-27
2.1.4 Summary of Analytical Results for Site FT-03	2-27
2.1.4.1 Soil Gas Survey	2-27
2.1.4.2 Soil Sampling	2-34
2.1.4.3 Site FT-03 Groundwater	2-37
2.1.4.4 Electrical Resistivity Surveys	2-37
2.2 Development of Conceptual Models.....	2-40
2.2.1 Intrinsic Remediation and Groundwater Flow and Solute Transport Models	2-40
2.2.2 Biodegradation of Dissolved BTEX Contamination	2-41
2.2.3 Initial Conceptual Models	2-42
2.2.3.1 Site FT-08	2-42
2.2.3.2 Site FT-03	2-43
2.2.4 Potential pathways and Receptors.....	2-44
2.2.4.1 Site FT-08	2-44
2.2.4.2 Site FT-03	2-44
3 Collection of Additional Data.....	3-1
3.1 Soil Sampling	3-2
3.1.1 Soil Sample Locations and Required Analyses	3-2
3.1.2 Sample Collection Using the Geoprobe® System.....	3-5
3.1.3 Datum Survey	3-8
3.1.4 Site Restoration.....	3-8
3.1.5 Equipment Decontamination Procedures.....	3-8
3.2 Monitoring Point Installation	3-9
3.2.1 Monitoring Point Locations and Completion Intervals	3-9
3.2.2 Monitoring point Installation Procedures	3-10
3.2.2.1 Pre-Placement Activities	3-10

TABLE OF CONTENTS (Continued)

3.2.2.2	Monitoring Point Materials Decontamination.....	3-11
3.2.2.3	Installation and Materials	3-11
3.2.2.4	Monitoring Point Completion or Abandonment	3-13
3.2.2.5	Monitoring Point Development and Records.....	3-14
3.2.4	Monitoring Point Location and Datum Survey	3-14
3.2.5	Water Level Measurements	3-16
3.3	Groundwater Sampling Procedures	3-16
3.3.1	Preparation for Sampling	3-17
3.3.1.1	Equipment Cleaning	3-17
3.3.1.2	Equipment Calibration	3-17
3.3.2	Sampling Procedures	3-19
3.3.2.1	Preparation of Location	3-19
3.3.2.2	Water Level and Total Department Measurements	3-19
3.3.2.3	Monitoring Well/Point Purging	3-20
3.3.2.4	Sample Extraction.....	3-20
3.3.3	Onsite Groundwater Parameter Measurement	3-20
3.3.3.1	Dissolved Oxygen Measurements	3-21
3.3.3.2	pH, Temperature, and Specific Conductance	3-21
3.3.3.3	Alkalinity Measurements	3-21
3.3.3.4	Nitrate- and Nitrite-Nitrogen Measurements	3-21
3.3.3.5	Carbon Dioxide Measurements	3-22
3.3.3.6	Sulfate and Sulfide Sulfur Measurements	3-22
3.3.3.7	Total Iron, Ferrous Iron, and Ferric Iron Measurements	3-22
3.3.3.8	Manganese Measurements	3-22
3.3.3.9	Redox Potential.....	3-22
3.4	Sample Handling for Laboratory Analysis	3-23
3.4.1	Sample Preservation	3-23
3.4.2	Sample Container and Labels	3-23
3.4.3	Sample Shipment.....	3-24
3.4.4	Chain-of-Custody Control	3-24
3.4.5	Sampling Records.....	3-24
3.4.6	Laboratory Analyses.....	3-25
3.5	Aquifer Testing.....	3-25
3.5.1	Definitions.....	3-25
3.5.2	Equipment.....	3-26
3.5.3	General Test Methods	3-26
3.5.4	Failing Head Test	3-27
3.5.5	Rising Head Test.....	3-29
3.5.6	Slug Test Data Analysis	3-29
4	Remedial Option Evaluation and TS Report	4-1
5	Quality Assurance/Quality Control	5-1
6	References	6-1
APPENDIX A	Containers, Preservatives, Packaging, and Shipping Requirements for Groundwater Samples	

TABLE OF CONTENTS (Continued)

APPENDIX B Additional Site Data

LIST OF TABLES

		<u>Page</u>
2.1	Summary of Well Installation Details and Groundwater Elevation Data, Site FT-08	2-9
2.2	Average Hydraulic Conductivity Values for Site FT-08	2-12
2.3	Summary of Well Installation Details and Groundwater Elevation Data, Site FT-03	2-16
2.4	Toluene Soil Gas Concentrations Measured at Site ST-08	2-19
2.5A	Summary of ES (1988) Soil Analytical Data Site FT-08	2-23
2.5B	Summary of UNC Geotech (1991) Soil Analytical Data Site FT-08	2-24
2.5C	Summary of O'Brien and Gere (1994) Soil Analytical Data Site FT-08	2-26
2.6	Summary of Ground Water Analytical Data Site FT-08	2-28
2.7	Toluene Soil Gas Concentrations Measured at Site FT-03	2-32
2.8	Summary of Soil Analytical Data Site FT-03	2-35
2.9	Summary of Ground Water Analytical Data Site FT-03	2-38
3.1	Analytical Protocol for Groundwater and Soil Samples Sites FT-03 and FT-08	3-3
4.1	Example TS Report Outline	4-2
5.1	QA/QC Sampling Program	5-2

LIST OF FIGURES

		<u>Page</u>
1.1	Base Location	1-4
1.2	Site Locations	1-5
1.3	Site FT-08 Layout	1-7
1.4	Site FT-03 Layout	1-8
2.1	Regional Topographic Base Map	2-3
2.2	Generalized Stratigraphic Column	2-4
2.3	Generalized Geologic Cross-Section of the Connecticut River Valley	2-5
2.4	Location of Cross-Section A-A'	2-7
2.5	Geologic Cross-Section A-A'	2-8
2.6	Water Table Elevation Contour Map Site FT-08, April 1987	2-11
2.7	Location of Cross-Section B-B'	2-14
2.8	Geologic Cross-Section B-B'	2-15
2.9	Water Table Elevation Contours Map Site FT-03, July 1993	2-18
2.10	Toluene Soil Gas Sampling Locations and Concentrations Site FT-08	2-20
2.11	Locations of UNC Geotech Soil Borings and Maximum Total BTEX Concentrations Site FT-08	2-22
2.12	Groundwater BTEX and TCE Concentrations Site FT-08	2-30

TABLE OF CONTENTS (Continued)

2.13	Soil Electrical Resistivity Map for 25-Foot Profile Depth Site FT-08	2-31
2.14	Toluene Soil Gas Sampling Locations and Concentrations Site FT-03	2-33
2.15	Contour Map of Total Oil and Grease in Soil Site FT-03	2-36
2.16	Groundwater BTEX and Chlorinated Solvent Concentrations Site FT-03	2-39
3.1	Proposed Geoprobe Sampling and/or Monitoring Point Installation Site FT-08	3-4
3.2	Cross Section of Geoprobe	3-6
3.3	Geologic Boring Log	3-7
3.4	Monitoring Point Installation Record	3-12
3.5	Monitoring Point Development Record	3-15
3.6	Groundwater Sampling Record	3-18
3.7	Aquifer Test Data Form	3-28

SECTION 1

INTRODUCTION

This work plan, prepared by Parsons Engineering Science, Inc. (Parsons ES), formerly Engineering Science, Inc.(ES), presents the scope of work required for the collection of data necessary to conduct a treatability study (TS) for remediation of groundwater contaminated with petroleum hydrocarbons and solvents at Site FT-08, the Current Fire Training Area, and Site FT-03, Christmas Tree Fire Training Area, located at Westover Air Reserve Base (ARB) in Chicopee, Massachusetts (the Base). Several remedial options will be evaluated during the TS, including free-phase product removal (if present); groundwater extraction, treatment, and disposal (i.e., pump and treat); bio-sparging; and natural contaminant attenuation (intrinsic remediation) with long-term monitoring. All hydrogeologic and groundwater chemical data necessary to evaluate the various remedial options will be collected under this program; however, this work plan is oriented toward the collection of hydrogeologic data to be used as input into groundwater flow and solute transport models in support of intrinsic remediation for restoration of fuel-hydrocarbon and chlorinated solvent contaminated groundwater.

As part of the TS, the modeling effort has three primary objectives: 1) predict the future extent and concentration of dissolved contaminant plumes by modeling the effects of advection, dispersion, sorption, and biodegradation; 2) assess the possible risk to potential downgradient receptors; and 3) to provide technical support for selection of the intrinsic remediation option as the best remedial alternative at regulatory negotiations, as appropriate. The modeling efforts for these sites will involve completion of several tasks, which are described in the following sections.

This work plan was developed based on discussions among representatives from the Air Force Center for Environmental Excellence (AFCEE), 439th Support Group/Civil Engineering (SPTG/CEV) personnel, and Parsons ES at a meeting at the Base February 8, 1995, to discuss the statement of work (SOW) for this project, and on a review of existing site characterization data. All field work will follow the health and safety procedures presented in the program *Health and Safety Plan for Bioplume II Modeling Initiative* (ES, 1993), the site-specific addendum to the program Health and Safety Plan, and an existing site health and safety plan (O'Brien and Gere, 1993). This work plan was prepared for AFCEE and the 439th SPTG/CEV.

1.1 SCOPE OF CURRENT WORK PLAN

The ultimate objective of the work described herein is to provide a TS for remediation of groundwater contamination at the Current Fire Training Area (Site FT-08) and Christmas Tree Fire Training Area (Site FT-03). However, this project is part of a larger, broad-based initiative being conducted by AFCEE in conjunction with the US Environmental Protection Agency (USEPA) and Parsons ES to document the biodegradation and resulting attenuation of fuel hydrocarbons and solvents dissolved in groundwater, and to model this degradation using the Bioplume II numerical groundwater model code. For this reason, the work described in this work plan is directed toward the collection of data in support of this initiative. All data required to develop a 30-percent design of an alternate groundwater remediation system, should intrinsic remediation not prove to be a viable remedial option at this facility, also will be collected under this program. This work plan describes the site characterization activities to be performed by personnel from Parsons ES and the USEPA's Robert S. Kerr Laboratory (RSKERL) in support of the TS and the groundwater modeling effort. Field activities will be performed to determine the extent of free-phase (if present) and dissolved contamination at both FT-08 and FT-03. In addition, the extent of residual soil contamination will be investigated at FT-08. A soil remediation system is being installed at FT-03; therefore, soils will not be investigated at this site. The data collected during the TS will be used along with data from previous investigations to complete the characterization of contamination at the sites, and for use in the groundwater flow and solute transport models to make predictions of the future concentrations and extent of contamination.

Site characterization activities in support of the TS will include: 1) determination of preferential contaminant migration pathways; 2) soil sampling using Geoprobe[®] direct-push technology; 3) groundwater monitoring point placement; 4) groundwater sampling; and 5) aquifer testing. The materials and methodologies required for collection of these data are described herein. Previously reported site-specific data and data collected during the supplemental site characterization activities described in this work plan will be used as input for the groundwater flow and solute transport models. Where site-specific data are not available, conservative values for the types of aquifer materials present at the site will be obtained from widely accepted published literature and used for model input. Sensitivity analyses will be conducted for the parameters which are known to have the greatest influence on the model results, and where possible, the model will be calibrated using historical site data. Upon completion of the modeling, Parsons ES will provide technical assistance at regulatory negotiations to support the intrinsic remediation option if the results of the modeling indicate that this approach is warranted. If it is shown that intrinsic remediation is not the most appropriate remedial option, Parsons ES will recommend the most appropriate groundwater remedial technology on the basis of available data.

This work plan consists of six sections, including this introduction. Section 2 presents a review of previously reported, site-specific data and conceptual models for the sites. Section 3 describes the proposed sampling strategy and procedures to be used for the collection of additional site characterization data. Section 4 describes the remedial option evaluation procedure and TS report format. Section 5 describes the

quality assurance/quality control (QA/QC) measures to be used during this project. Section 6 contains the references used in preparing this document. There are two appendices to this work plan. Appendix A contains a listing of containers, preservatives, packaging, and shipping requirements for soil and groundwater samples. Appendix B contains a summary of historical soil and groundwater analytical data from previous field investigation work.

1.2 BACKGROUND

Westover ARB is located in south-central Massachusetts. The Base covers approximately 2,400 acres in the northeastern portion of the city of Chicopee, within the Connecticut River Valley (Figure 1.1). The Base is in close proximity to Interstate 90 (the Massachusetts Turnpike) and I-91 (a major north-south route), and is 90 miles west of Boston. Westover ARB is in Hampden County, and the land use around the Base is a mix of rural, residential and industrial/commercial development.

The Base became operational in April 1940 and initially served as a training center for the 359th Fighter Group until 1945. After World War II, the Base served the Air Transport Command, which in 1948 became the Military Air Transport Services. From 1956 to 1974, the Base was used by Strategic Air Command (SAC) crews operating B-52s. Westover's 99th Bomb Wing was the primary SAC unit flying missions in the Vietnam War. The Air Force Reserve came to Westover in 1965, and in 1974 the Base was deactivated to become an Air Force Reserve Base. Westover's world-wide mission increased with the arrival of 16 C-5A's in 1987. Currently the Base is the nation's largest Air Force Reserve Base and is operated by a work force of 1,200 civilians, including 533 Air Reserve technicians. Over 4,000 reservists from all military branches throughout the Northeast serve at Westover ARB.

In 1982, an Installation Restoration Program (IRP) records search was conducted by CH2M Hill (CH2M Hill, 1982). At this time the Current Fire Training Area and Christmas Tree Fire Training Area were identified as hazardous waste sites due to the regular use of fuels and solvents as a part of fire training exercises. Since 1982, several studies have been performed to confirm and quantify the level of contamination at the two sites. In 1984, Weston Environmental conducted work for a Phase II Confirmation Study. ES (1988) was responsible for site characterization activities in 1986, and the resulting Phase II, Confirmation/Qualification Stage 2 Report (1988). UNC Geotech (1991) conducted work in 1989 for a Remedial Investigation/Feasibility Study (RI/FS) of 8 sites, including FT-08 and FT-03. In 1993 and 1994 O'Brien and Gere Engineers collected field data to produce a supplemental RI/FS. The soil and groundwater data acquired from these investigations indicate that fuel hydrocarbon and solvent contamination is present at both sites.

1.2.1 Current Fire Training Area

The Current Fire Training Area (FT-08) is located in the northern portion of the Base (Figure 1.2). FT-08 was used from 1964 to 1986, for monthly fire training exercises in which fuels were spread over a metal replica of an aircraft fuselage and ignited. The volume of petroleum products and spent solvents used in the training area

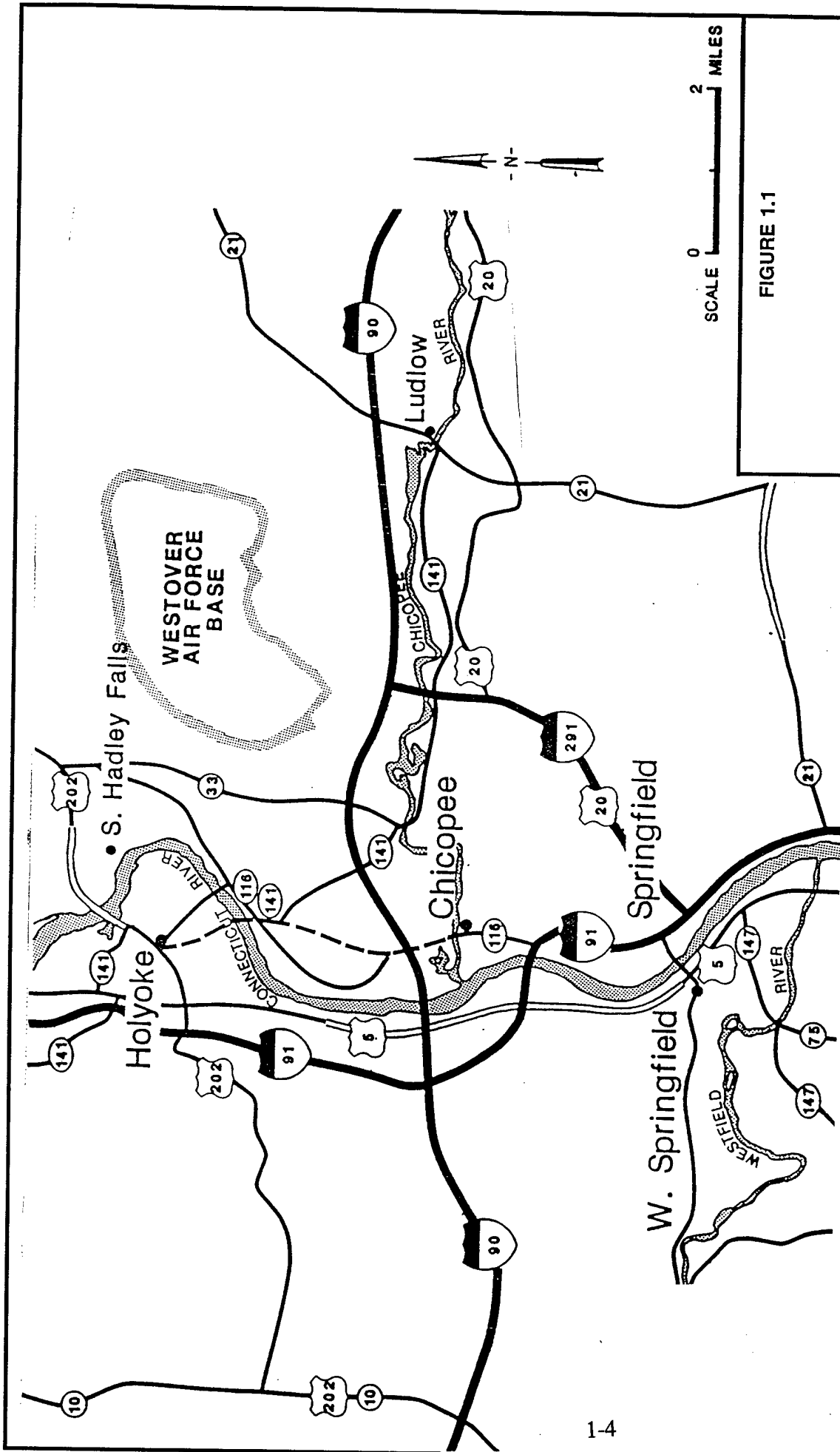

FIGURE 1.1

BASE LOCATION

Intrinsic Remediation TS
 Westover ARB, Massachusetts



**PARSONS
 ENGINEERING SCIENCE, INC.**
 Denver, Colorado

CURRENT FIRE
TRAINING AREA
"FT-08"

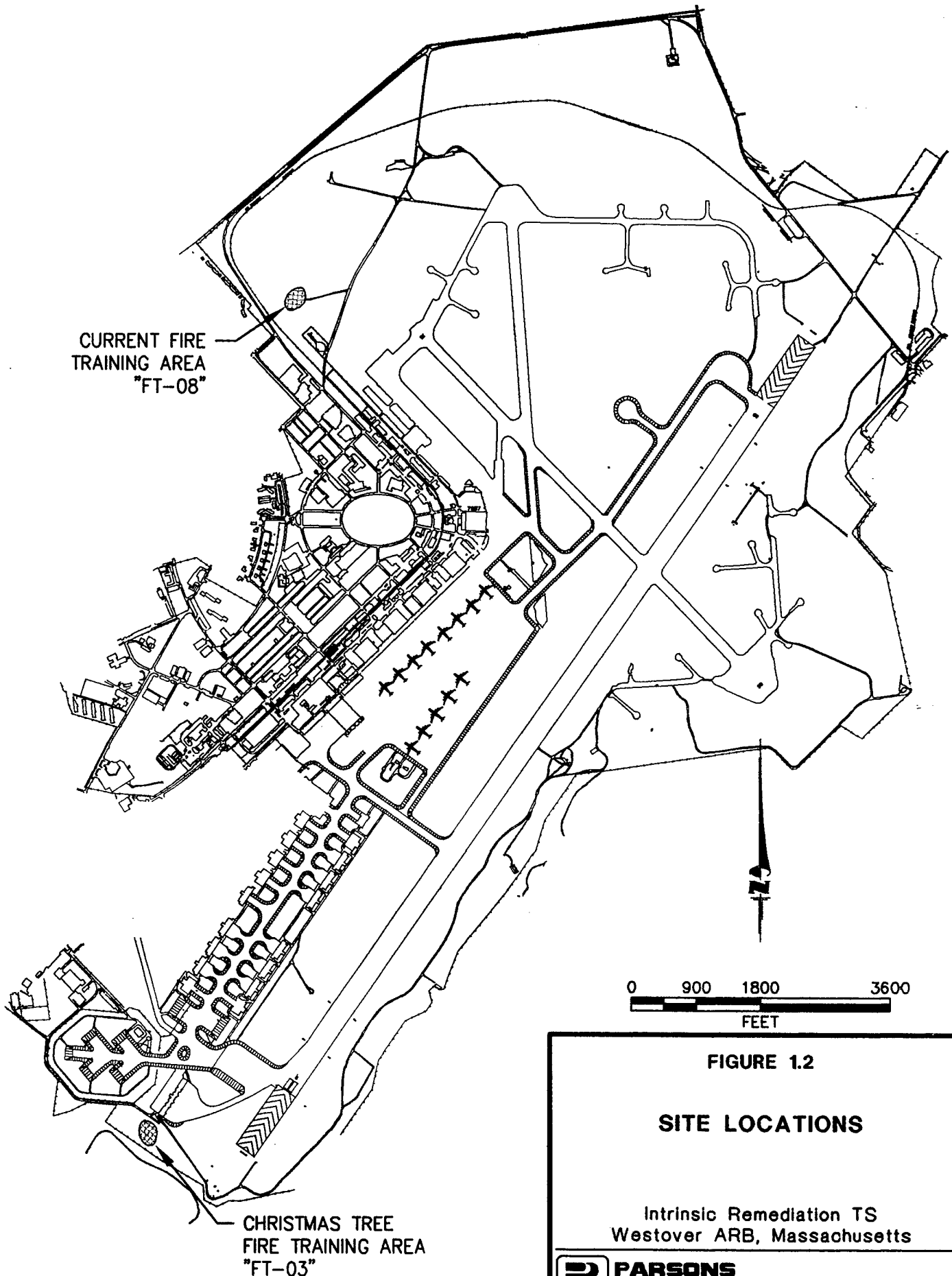

CHRISTMAS TREE
FIRE TRAINING AREA
"FT-03"



FIGURE 1.2

SITE LOCATIONS

Intrinsic Remediation TS
Westover ARB, Massachusetts

 **PARSONS
ENGINEERING SCIENCE, INC.**

Denver, Colorado

Source: (Westover ARB, 1993)

prior to 1974 is unknown. From 1974 to 1986, approximately 125 gallons of JP-4 jet fuel per month was used in the exercises. A buried waste fuel tank is located northwest of the burn area. A buried fuel line runs from the tank to the edge of the burn area (Figure 1.3) (O'Brien and Gere, 1993a). Northeast of the site is a buried storm sewer drainage line.

The burn area is approximately 150 feet in diameter and consists of sparsely vegetated sand, gravel, and cinder soil. The area surrounding the site is primarily open space with an access road entering the site from the east (Figure 1.3). Previous investigations have detected benzene, toluene, ethylbenzene, and xylenes (BTEX) and chlorinated solvent contamination in soil samples collected from the burn area and the soil around the waste fuel tank. Contamination also has been detected in groundwater samples collected within and downgradient from the burn area.

1.2.2 Christmas Tree Fire Training Area

The Christmas Tree Fire Training Area (FT-03) is located in the southwestern portion of the Base, about 200 feet north of the southern Base boundary, (Figures 1.2 and 1.4). Chicopee Memorial State Park lies south of the Base boundary, and the Chicopee Reservoir, located within the park, is approximately 0.4 mile southeast of FT-03. Site FT-03 was used for fire training exercises from 1940 to 1964. The volume of waste fuels and solvents released at the site as a result of fire training exercises is unknown. UNC Geotech (1991) reported that incinerator trash, including ashes, tires, rubble, unburned metal, wood, plastics, and general debris have at some time been deposited at FT-03. A buried 8-inch JP-4 fuel line is located in the northern portion of the site (ES, 1988).

Site FT-03 is covered with sparsely vegetated soil consisting of sand, gravel, and cinders. A portion of the site is currently used as a parking area for trucks and troop transports (O'Brien and Gere, 1993). There is no visual evidence of contamination related to use as a fire training area. Results from previous investigations have identified petroleum hydrocarbon contamination in soil samples from depths up to 10 feet below ground surface (bgs). BTEX and chlorinated solvent contamination has been detected in shallow groundwater samples collected at locations within and downgradient from the burn area.

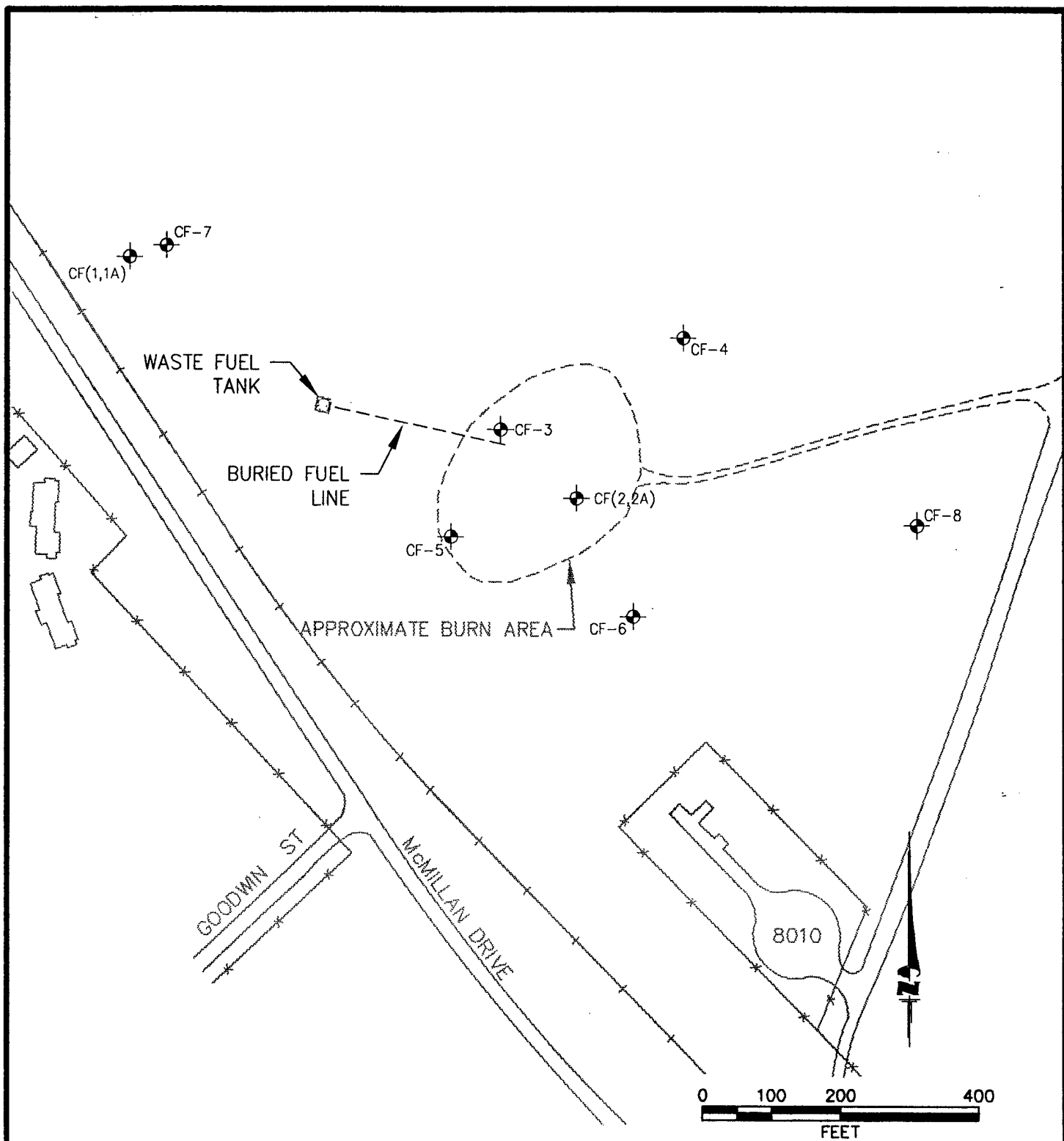

LEGEND



- 
MONITORING WELL
- 
RAILROAD TRACK
- 
FENCE

FIGURE 1.3

**SITE LAYOUT
FT-08**

Intrinsic Remediation TS
Westover ARB, Massachusetts

**PARSONS
ENGINEERING SCIENCE, INC.**

Denver, Colorado

Source: O'Brien and Gere, 1994.

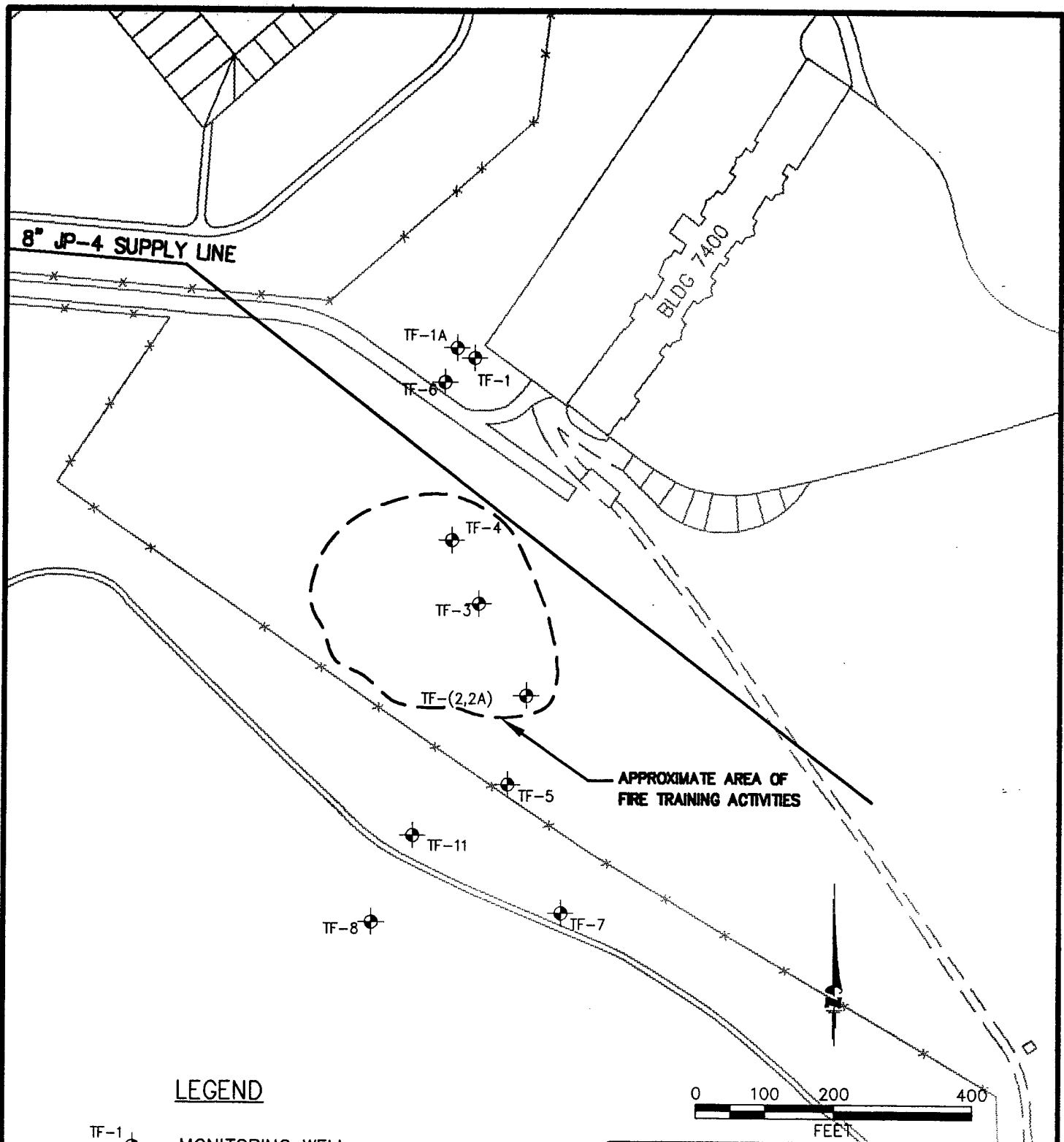

LEGEND

- TF-1  MONITORING WELL
-  FENCE



FIGURE 1.4

SITE FT-03 LAYOUT

Intrinsic Remediation TS
Westover ARB, Massachusetts

 **PARSONS
ENGINEERING SCIENCE, INC.**

Denver, Colorado

Source: O'Brien and Gere, 1994

SECTION 2

DATA REVIEW AND CONCEPTUAL MODEL DEVELOPMENT

Existing site-specific data were reviewed and used to develop conceptual models for the groundwater flow and contaminant transport at FT-08 and FT-03. The conceptual models guided the development of sampling locations and analytical data requirements needed to support the modeling efforts and to evaluate potential remediation technologies, including intrinsic remediation. Section 2.1 presents a synopsis of available site characterization data. Section 2.2 presents the preliminary conceptual groundwater flow and contaminant transport models that were developed based on these data.

2.1 DATA REVIEW

The following sections are based upon review of data from the following sources:

- Ground Water Monitoring Report for Site FT-03 "Christmas Tree" Fire Training Area (O'Brien and Gere, 1995);
- Supplemental Remedial Investigation/Feasibility Study Report (O'Brien and Gere, 1994);
- IRP Work Plan (O'Brien and Gere, 1993);
- Final RI Report (UNC Geotech, 1991)
- IRP Phase II-Confirmation/Quantification Stage 2 Report (ES, 1988);
- Final Report, Phase II - Problem Confirmation Study (Weston, 1984); and
- IRP Records Search (CH2M Hill, 1982);

2.1.1 Topography, Surface Hydrology, and Climate

Westover ARB is located within the Connecticut River Valley Lowland Subdivision of the New England Upland Physiographic Province, which is part of the Northern Appalachian Mountain System. The predominant topographic features of the area are the nearly level flood plains, level to gently sloping terraces along the Connecticut River, and several large intrusive dikes that rise several hundred feet above the valley floor (ES, 1988). Regional elevations range from 50 feet above mean sea level (msl) at the Connecticut River to 1,200 feet msl to the north of the Base at Mount Tom.

The Base is located approximately 2 miles east of the Connecticut River and is drained by three smaller drainages: Stony Brook in the north, Willamansett Brook to

the west, and Cooley Brook along the southeastern boundary of the Base (Figure 2.1). Langewald Pond and Mountain Lake, west of the Base, receive water from Willamansett Brook. Cooley Brook receives runoff from most of the industrial operations, site FT-03, flight line hangars, and runways via storm sewers, culverts, and ditches. Oil/water separators have been constructed along Cooley Brook to filter storm runoff prior to discharge into the brook (O'Brien and Gere, 1993). Cooley Brook supplies water to Chicopee Reservoir (2,000 feet southeast of FT-03) and the Chicopee River (approximately 1 mile south of the Base). Stony Brook, a tributary of the Connecticut River, receives runoff from the northern portion of the Base, mainly through storm drains which outfall at the brook south and east of Landfill A (O'Brien and Gere, 1993). Surface water flow in the vicinity of FT-08 is north to northwest, into the Stony Brook watershed.

The climate in south central Massachusetts is typified by cold winters and moderately warm summers. The temperatures range from a mean high of 83 degrees Fahrenheit (°F) in July to a mean low of 16°F in January. Temperatures expected during field work (scheduled for the month of May) typically range from a mean high of 69°F to a mean low of 47°F. The relative humidity averages about 63 percent during the month of May. Precipitation averages 42 inches per year, with the maximum precipitation typically occurring during the months of July through September. May is usually the driest month, with a mean precipitation total of 2.8 inches. The mean annual wind speed is 6 knots from the south.

2.1.2 Overview of Geology and Hydrogeology

2.1.2.1 Regional Geology and Hydrogeology

The central Massachusetts bedrock geology consists of a variety of Precambrian and early Paleozoic crystalline rocks known as the Grenville crystallines (ES, 1988). These rocks are most evident as the Adirondack Mountains to the west of the Base. The crystalline rocks underwent periods of folding, faulting, metamorphism, and intrusion during the Taconic (Ordovician) and Acadian (Devonian) orogenies. The resulting stresses from these orogenies produced extensive folding and faulting during the Mesozoic. Additional folding and rifting occurred in the early Jurassic periods, and a series of north-south trending fault structures were formed. Unconformably overlying the crystallines are Triassic "redbeds" consisting of arkosic sandstone, conglomerates, siltstones, and occasional gray shales. The Triassic rocks in the Westover ARB area are reddish-brown arkosic sand and siltstones of the Portland Formation. Uplift and erosion of the Triassic formations resulted in an unconformity between the Portland Formation and Pleistocene glacial sediments (Figure 2.2).

The Pleistocene glacial advance reshaped the landscape and deposited poorly sorted gravel, sand, silt, and clay mixtures as moraines and till sheets (Figure 2.3). During the glacial retreat, melt waters impounded by glacial deposits and existing topography formed several large glacial lakes. The largest of the Pleistocene lakes in the region was glacial Lake Hitchcock, which extended from Hartford, Connecticut to Lyme, New Hampshire. The lake was as much as 250 feet deep in the Chicopee area (Thomas, 1987). The resulting sedimentation deposited thick, gray, varved lacustrine

Era	Period	Epoch	Unit	Columnar Section	Thickness in Feet	Typical Lithologic Characteristics
Cenozoic	Quaternary	Recent	Fill/Landfill		0-15'	Fine to Medium Loose Sand Trace - Gravel
			Swamp		0-3.5'	Peat, Fibers, Fine Sand and Silt
		Pleistocene	Deltaic Deposits		0-70' ±	Brown to Gray, Fine to Coarse Sand, None to Trace, Gravel and Silt, Grading Finer with Depth
			Lacustrine Deposits		10-250' ±	Gray Varved Clays Fine Sand and Silt Laminae
			Glacial Till Large Unconformity		0-20' ±	Nonstratified Gravel, Sand, Silt, Clay Admixtures - Poorly Sorted
Mesozoic	Triassic	Triassic Bedrock			Sedimentary Strata with Many Crevices	
Paleozoic	Pretriassic	Large Nonconformity Crystalline Bedrock			Metamorphic Strata with Few Crevices	

FIGURE 2.2

**GENERALIZED
STRATIGRAPHIC
COLUMN**

Intrinsic Remediation TS
Westover ARB, Massachusetts



**PARSONS
ENGINEERING SCIENCE, INC.**

Denver, Colorado

Source: Weston, 1984.

clays with silt and fine sand laminations. Overlying the lacustrine sediments are brown to gray, fine to coarse sands with traces of gravel and silt. These sediments are deltaic outwash deposits that formed as glacial Lake Hitchcock drained and filled with sediment.

The regional hydrogeology of the Westover ARB area consists of three major hydrogeologic units. An aquitard composed of lacustrine deposits and till separates the shallow deltaic outwash aquifer from the underlying Triassic bedrock aquifer. Both aquifers are used to a limited extent for industrial, municipal, and domestic purposes (O'Brien and Gere, 1993). Because of the thick aquitard, it is considered unlikely that site contaminants in the shallow aquifer could adversely impact the Triassic bedrock aquifer. The glacial outwash aquifer ranges in thickness from 25 to 85 feet in the area of the Base, and is recharged by infiltration and runoff from rain and melting snow (O'Brien and Gere, 1993). Depth to groundwater is generally 5 to 40 feet bgs and is influenced by surface topographic features. The hydraulic conductivity for silty sands and clean sands typical of outwash deposits ranges from 0.03 to 2,800 feet per day (ft/day) (Freeze and Cherry, 1979). Pump tests performed by UNC Geotech (1991) determined the hydraulic conductivity at the base to average 13 ft/day and range from 2.2 to 33 ft/day.

2.1.2.2 FT-08 Geology and Hydrogeology

Sediments at FT-08 consist primarily of fine- to coarse-grained sands and gravels, overlying varved silt and clay lacustrine deposits. Sediments above the lacustrine deposits coarsen upward, as is typical of a deltaic depositional environment. Sands are loose to medium dense, tan to brown, and very fine to coarse grained. Within the coarse sands, gravel-sized material is also present. Past investigations have reported the upper 5 feet of soil to be a medium dense, light brown, fine sand to gravel fill. Below the fill is a 30- to 40- foot-thick, loose to medium dense sand and gravel layer. Underlying the sand and gravel, approximately 10 feet of fine silty sand and 20 feet of fine sand are present. Figure 2.4 shows the location of stratigraphic cross-section A-A' at site FT-08. Figure 2.5 is cross-section A-A' of the site in an east-west direction. This cross-section details the interlayering of fine sands and coarse sand and gravels characteristic of this type of depositional environment.

In 1986, ES installed six monitoring wells at FT-08. Additional wells were installed by UNC Geotech in 1988 and by O'Brien and Gere in 1993. Monitoring well construction details and groundwater elevations for FT-08 monitoring wells are provided in Table 2.1. Figure 2.6 shows the groundwater surface for the northern portion of Westover ARB, including Site FT-08, in April 1987.

In the immediate vicinity of the site, the groundwater flow direction is to the southeast, while the local groundwater flow direction along the northern boundary of the Base is generally to the east. Overall the depth to groundwater is 4 to 6 feet bgs (240 to 242 feet msl) throughout the year. The hydraulic gradient was estimated from the April 1987 groundwater elevations at 0.002 foot per foot (ft/ft) in the upper portions of the deltaic outwash aquifer. The relatively flat groundwater gradient can in part be attributed to the lack of influential topography present at the site. A similarly

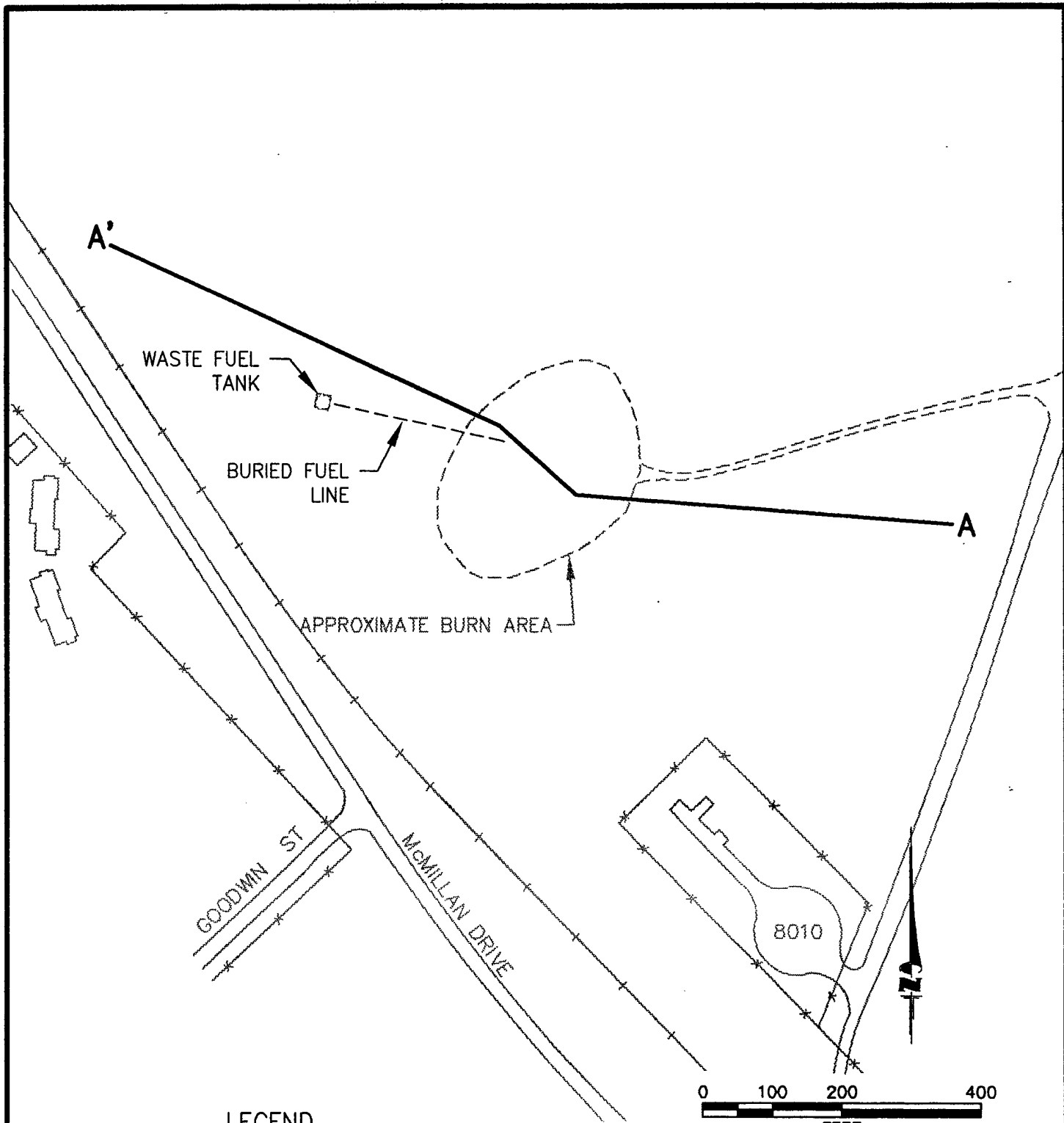

LEGEND



- CF-5  MONITORING WELL
-  RAILROAD
-  FENCE
- A' ——— A GEOLOGIC CROSS-SECTION LOCATION

FIGURE 2.4
LOCATION OF CROSS-SECTION
A-A'
SITE FT-08

Intrinsic Remediation TS
 Westover ARB, Massachusetts

 **PARSONS**
ENGINEERING SCIENCE, INC.

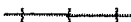
Denver, Colorado

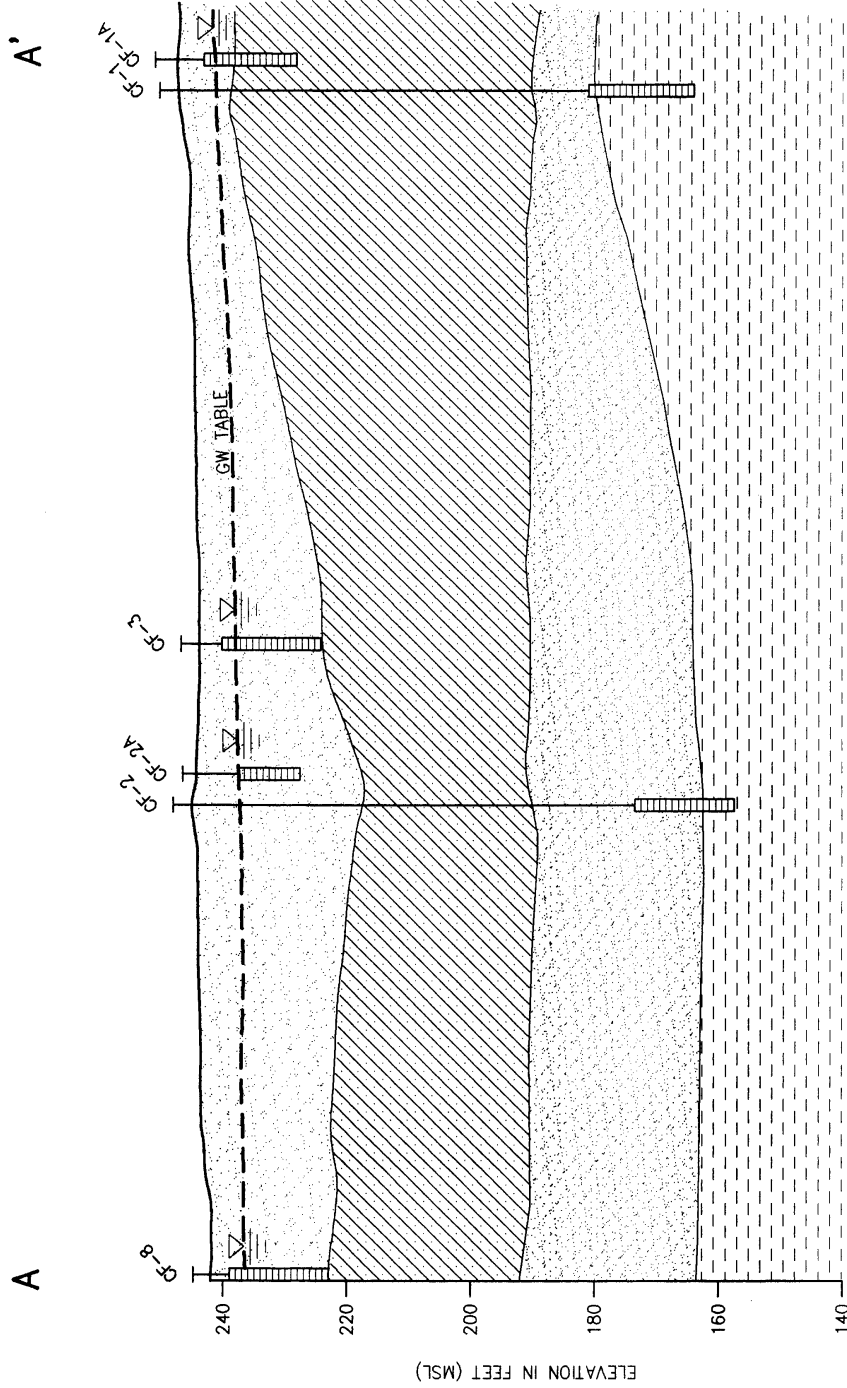

LEGEND

WATER TABLE, 3/24/94

SCREENED INTERVAL

FINE TO MEDIUM SANDS

FINE SILTY SANDS

FINE SAND

VARVED SILT, CLAY AND SAND LACUSTRINE DEPOSITS



FIGURE 2.5

GEOLOGIC CROSS-SECTION A-A' SITE FT-08

Intrinsic Remediation TS
Westover ARB, Massachusetts



Denver, Colorado

7-R

TABLE 2.1
SUMMARY OF WELL INSTALLATION DETAILS AND
GROUNDWATER ELEVATION DATA, SITE FT-08
 INTRINSIC REMEDIATION TS
 WESTOVER ARB, MASSACHUSETTS

Well Identification	Measurement Date	Northing	Easting	Total Borehole Depth (feet bgs)	Well		Screen Interval (feet msl)	Approx Land Surface (feet msl)	Elevation Top of PVC ^{a/} (feet msl)	Depth to	
					Completion Depth (feet bgs)	Depth (feet bgs)				Water From Top of PVC (feet btoc) ^{b/}	Elevation of Water (feet msl)
CF-1	1/23/87	315,304	441,978	92	87	175.3-160.3	247.26	249.85	6.03	243.82	
	3/05/87								9.15	240.70	
	4/21/87								7.31	242.54	
	10/30/88								10.42	239.43	
CF-1A	1/23/87	315,308	441,982	20	20	242.2-227.2	247.19	249.59	7.08	242.51	
	3/05/87								7.37	242.22	
	4/21/87								4.31	245.28	
	10/30/88								10.94	238.65	
CF-2	1/23/87	315,944	441,647	92	89	171.1-156.1	245.13	248.19	8.21	239.98	
	3/05/87								8.46	239.73	
	4/21/87								6.59	241.60	
	10/30/88								9.40	238.79	
CF-2A	1/23/87	315,943	441,640	15	15	240.2-230.2	245.25	247.52	7.48	240.04	
	3/05/87								7.92	239.60	
	4/21/87								5.97	241.55	
	10/30/88								8.65	238.87	
CF-3	1/23/87	315,828	441,734	22	19.5	240.4-225.4	244.87	246.91	6.54	240.37	
	3/05/87								6.68	240.23	
	4/21/87								4.96	241.95	
	10/30/88								7.85	239.06	
CF-4	1/23/87	316,097	441,863	23	20	238.6-223.6	243.62	245.99	5.46	240.53	
	3/05/87								5.79	240.20	
	4/21/87								4.13	241.86	
	10/30/88								6.79	239.20	

TABLE 2.1 (CONTINUED)
SUMMARY OF WELL INSTALLATION DETAILS AND
GROUNDWATER ELEVATION DATA, SITE FT-08
 INTRINSIC REMEDIATION TS
 WESTOVER ARB, MASSACHUSETTS

Well Identification	Measurement Date	Northing	Easting	Total Borehole Depth (feet bgs)	Well Completion Depth (feet bgs)	Screen Interval (feet msl)	Approx Land Surface (feet msl)	Elevation Top of PVC ^{a/} (feet msl)	Depth to	
									Water From Top of PVC (feet btoc) ^{b/}	Elevation of Water (feet msl)
CF-5	1988?	315,760	441,584	20	20	242.4-227.4	244.90	247.81	-	-
CF-6	1988?	316,037	441,475	90	90	171.5-156.5	244.50	245.84	-	-
CF-6A	1988?	316,037	441,475	20	20	241.5-226.5	244.50	246.52	-	-
CF-7	1988?	315,338	442,007	95	95	246.0-162.0	247.00	248.71	-	-
CF-8 ^{c/}	6/16/93			22	20	10-20 ^{d/}				

Source: ES, 1988; UNC Geotech, 1991; O'Brien and Gere, 1994 and 1995.

^{a/} PVC = polyvinyl chloride well casing.

^{b/} Feet btoc = feet below top of casing.

^{c/} Data approximated from well logs.

^{d/} Feet btoc.

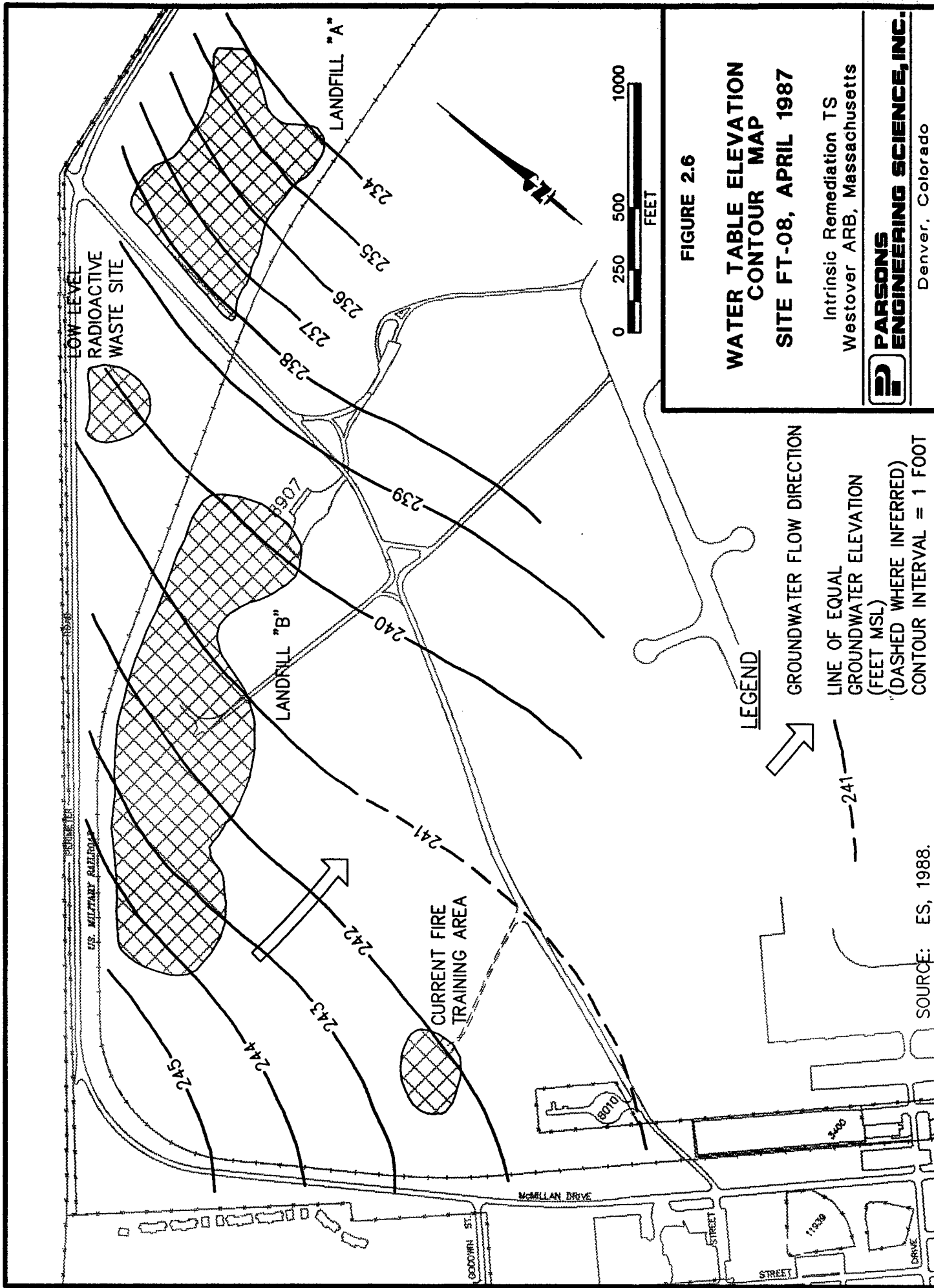

FIGURE 2.6

**WATER TABLE ELEVATION
CONTOUR MAP**
SITE FT-08, APRIL 1987

Intrinsic Remediation TS
Westover ARB, Massachusetts



**PARSONS
ENGINEERING SCIENCE, INC.**
Denver, Colorado

- LEGEND**
- GROUNDWATER FLOW DIRECTION
 - LINE OF EQUAL GROUNDWATER ELEVATION (FEET MSL) (DASHED WHERE INFERRED)
 - CONTOUR INTERVAL = 1 FOOT

SOURCE: ES, 1988.

flat gradient is suggested by the 1993 groundwater elevation data (O'Brien and Gere, 1993). A gradient of approximately 0.001 ft/ft to the south-southeast was estimated, excluding an anomalous groundwater elevation at well CF-6.

The authors of the 1991 RI report concluded that there is a groundwater divide in the vicinity of FT-08. A potential effect of the divide is that a contaminant plume originating from this location may diverge in several directions, and the magnitude of the divergence may be complicated due to seasonal fluctuations in the water table (UNC Geotech, 1991). These observations were derived from a groundwater model that was calibrated to the measured groundwater hydraulic heads and that assumed recharge from 100-percent of annual precipitation. While a groundwater divide may exist, Parsons ES disagrees with the model assumption that 100 percent of the annual precipitation recharges the aquifer.

Using pump test results from monitoring well CF-1A, UNC Geotech (1991) estimated the outwash transmissivity to be 1,150 square feet per day (ft²/day) and storativity to be approximately 0.01 (ft/ft). The results from single-well slug tests determined the range of site hydraulic conductivities present in Table 2.2.

TABLE 2.2
AVERAGE HYDRAULIC CONDUCTIVITY
VALUES FOR SITE FT-08
INTRINSIC REMEDIATION TS
WESTOVER ARB, MASSACHUSETTS

Well	Hydraulic Conductivity	
	(ft/day)	(ft/min)
CF-1	14	0.0097
CF-1A	14	0.0097
CF-2	24	0.017
CF-2A	16	0.011
CF-3	10	0.0069
CF-4	2.6	0.0018

Source: UNC Geotech, 1991.

2.1.2.3 Site FT-03 Site Geology and Hydrogeology

The soil at FT-03 consists of light-colored, fine to medium sands which range in thickness from 0 to 20 feet and were classified during a previous ES (1988) investigation as disturbed base material. Underlying the surficial soils is a 10- to 40-foot-thick, well-sorted, interbedded sand and sandy gravel, with some clean coarse gravel seams present. Below the sand and gravel are layers of fine sand and silty sand. At approximately 80 feet bgs, lacustrine varved silts and clays are present (O'Brien and Gere, 1994). These sediments are up to 40 feet thick and consist of silts and clays that form an aquitard. Underlying the aquitard unit are the thin glacial till and Triassic bedrock units present throughout the Chicopee region. Figure 2.7 shows the location of the geologic cross section B-B' which is presented on Figure 2.8.

In 1986, ES (1988) installed monitoring wells TF-1 through TF-6 and obtained water level measurements. Monitoring wells TF-7 and TF-8 were installed by UNC Geotech in 1988, and monitoring well TF-11 was installed in 1993 by O'Brien and Gere. Site FT-03 monitoring well construction details and groundwater elevations are provided in Table 2.3. Figure 2.9 illustrates the groundwater surface and flow direction based on July 1993 data. Groundwater depth at the site is generally 40 to 45 feet bgs, and the flow direction is to the south. Single-well slug tests conducted by UNC Geotech on wells TF-1 and TF-2 yielded hydraulic conductivities of 4.5 and 12 ft/day, respectively. The site hydraulic gradient is relatively steep, at about 0.07 ft/ft (UNC Geotech, 1991).

2.1.3 Summary of Analytical Results at Site FT-08

2.1.3.1 Soil Gas Survey

In 1991, UNC Geotech performed a soil gas survey at site FT-08 using a gas chromatograph calibrated for toluene. The results were then used to select the locations of additional soil borings and samples. Eighty-eight soil gas samples were collected over an 800- by 600-foot grid. The results of the soil gas survey indicate the presence of petroleum hydrocarbons in specific regions of the site (Table 2.4). In the UNC Geotech (1991) report, contradictory information is presented in the text and figure pertaining to the soil gas survey. Evaluation of the data suggests that the soil gas grid in the figure was misplotted by approximately 200 feet. A reinterpretation of the soil gas grid and corresponding results are presented on Figure 2.10.

As shown on Figure 2.10, high concentrations of toluene were noted at grid locations corresponding to suspected source areas. The highest concentration of toluene in the soil gas, 230,000 parts per billion volume per volume (ppbv), was observed at a location corresponding to the center of the main burn pit. Additional high toluene concentrations (greater than 2,000 ppbv) were observed in areas coinciding with the burn area. High toluene soil gas concentrations around the burn area are the result of the controlled releases associated with fire training activities. The area of approximate elevated toluene soil gas concentrations trends north-northwest across the burn site and measures approximately 400 feet by 100 feet. A toluene soil gas concentration of 127,500 ppbv was observed at the location of the abandoned waste

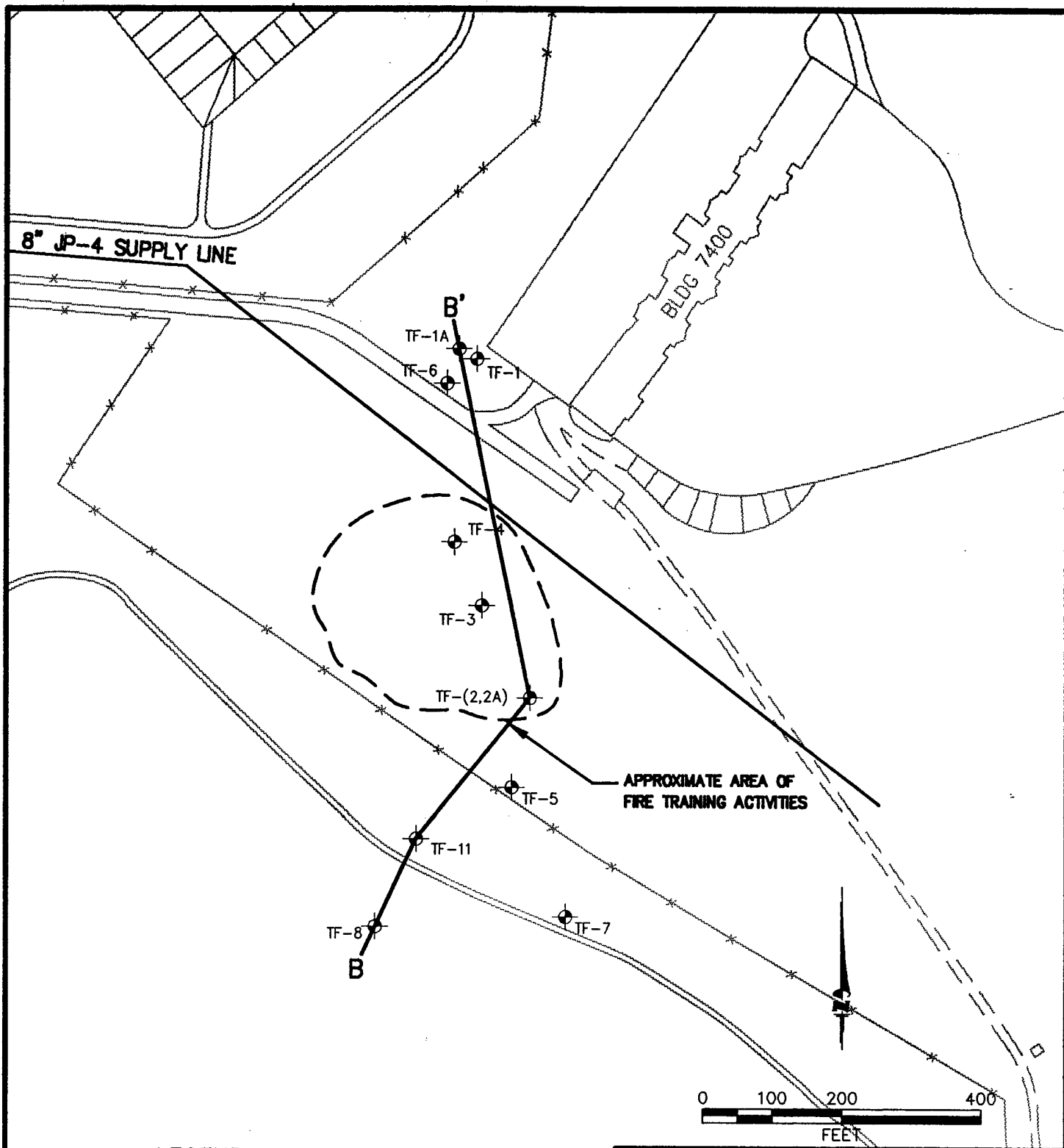

LEGEND

- TF-1 MONITORING WELL LOCATION
- FENCE
- B—B'** GEOLOGIC CROSS-SECTION LOCATION



FIGURE 2.7

**LOCATION OF
CROSS-SECTION B-B'
SITE FT-03**

Intrinsic Remediation TS
Westover ARB, Massachusetts

**PARSONS
ENGINEERING SCIENCE, INC.**

Denver, Colorado

Source: O'Brien and Gere, 1994.

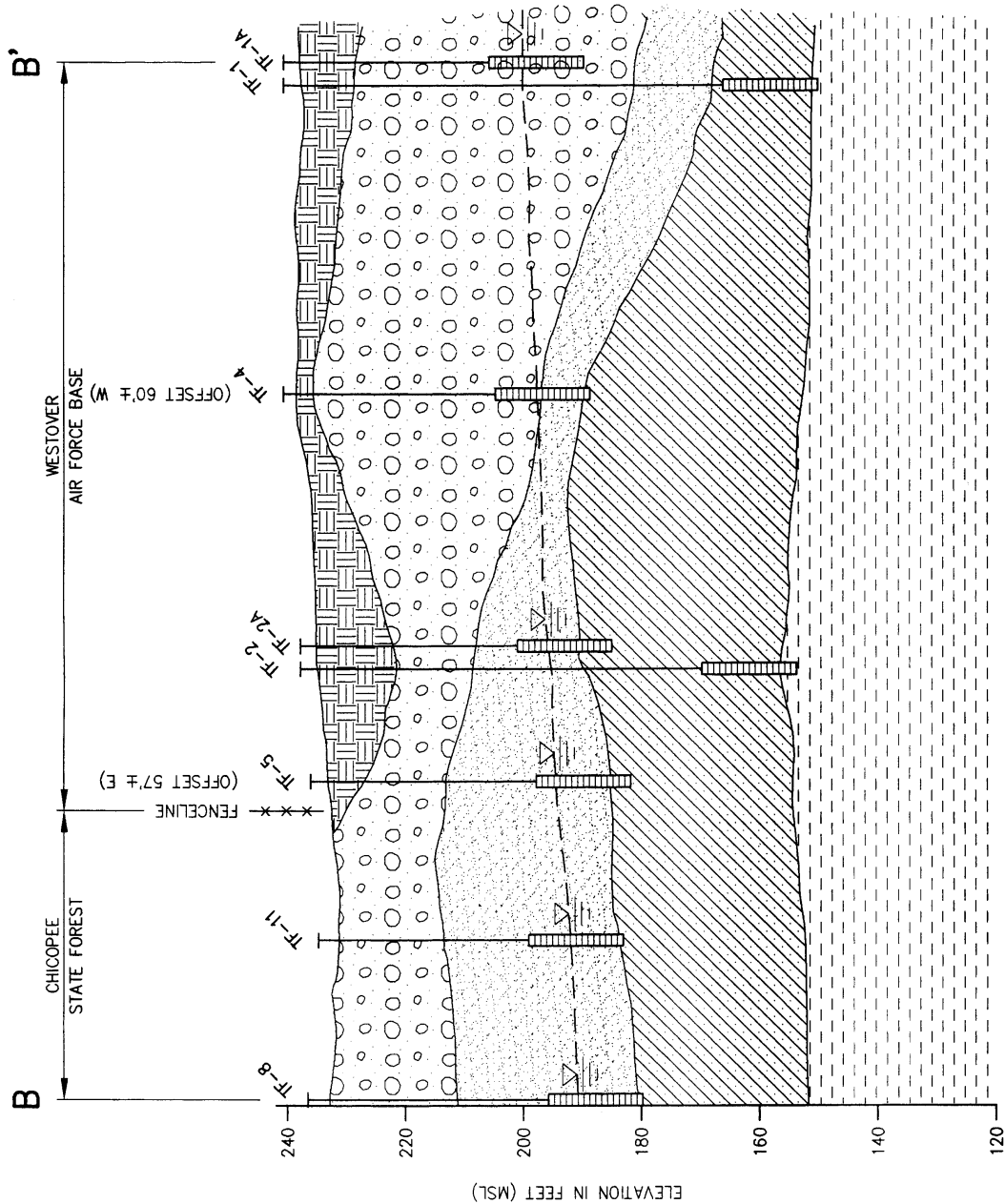

LEGEND

- ▽ = WATER TABLE - 12/94
- ▭ = SCREENED INTERVAL
- ▭ = BASE FILL
- ▭ = SAND AND GRAVEL
- ▭ = FINE SAND
- ▭ = FINE SILTY SAND
- ▭ = VARVED SILT, CLAY, AND SAND LACUSTRINE DEPOSITS

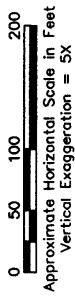

FIGURE 2.8
GEOLOGIC CROSS-SECTION B-B'
SITE FT-03

Intrinsic Remediation TS
 Westover ARB, Massachusetts

PARSONS ENGINEERING SCIENCE, INC.
 Denver, Colorado

TABLE 2.3
SUMMARY OF WELL INSTALLATION DETAILS AND
GROUNDWATER ELEVATION DATA, SITE FT-03
 INTRINSIC REMEDIATION TS
 WESTOVER AFB, MASSACHUSETTS

Well Identification	Installation Date	Northing	Easting	Total Borehole		Screen Interval (feet bgs)	Approx Land Surface (feet msl)	Elevation Top of PVC ^{aw} (feet msl)	Depth to Water			
				Depth (ft)	Completion Depth (feet bgs)				From Top of PVC (feet bgs) ^{bv}	Elevation of Water (feet msl)		
TF-1	1/23/87	313,835	430,521	92	92	161.6-146.6	235.60	238.64	42.26	196.38		
	3/5/87										42.51	196.13
	4/21/87										41.63	197.01
	10/30/88										42.30	196.34
TF-1A	1/23/87	313,830	430,524	50	50	200.6-185.6	235.60	238.14	41.59	196.55		
	3/5/87										41.98	196.16
	4/21/87										41.03	197.11
	10/30/88										41.58	196.56
	7/93										40.29	197.85
12/94	40.97	197.18										
TF-2	1/23/87	313,913	430,043	87	87	164.4-149.4	232.90	236.14	44.74	191.40		
	3/5/87										44.92	191.22
	4/21/87										44.02	192.12
	10/30/88										44.49	191.65
12/94	43.82	192.44										
TF-2A	1/23/87	313,916	430,044	52	52	195.9-180.9	232.90	235.24	43.27	191.97		
	3/5/87										43.56	191.68
	4/21/87										42.53	192.71
	10/30/88										43.15	192.09
12/94	42.55	192.82										
TF-3	1/23/87	313,742	430,126	54	54	196.6-181.6	233.60	235.87	43.14	192.73		
	3/5/87										43.35	192.52
	4/21/87										42.64	193.23
	10/30/88										42.91	192.96
12/94	43.02	192.80										

TABLE 2.3 (CONTINUED)
 SUMMARY OF WELL INSTALLATION DETAILS AND
 GROUNDWATER ELEVATION DATA, SITE FT-03

INTRINSIC REMEDIATION TS
 WESTOVER ARB, MASSACHUSETTS

Well Identification	Installation Date	Northing	Easting	Total Hole Depth (ft)	Well		Approx Land Surface (feet msl)	Elevation Top of PVC ^{a/} (feet msl)	Depth to Water From Top of PVC (feet bgs) ^{b/}	Elevation of Water (feet msl)		
					Completion Depth (feet bgs)	Screen Interval (feet bgs)						
TF-4	1/23/87	313,848	430,255	52	52	199.0-184.0	236.00	238.22	43.81	194.41		
	3/5/87										43.98	194.24
	4/21/87										43.33	194.89
	10/30/88							43.65	194.57			
TF-5	10/30/88	313,867	429,951	55	55	196.8-181.8	231.80	233.88	41.12	192.76		
	7/93										42.57	191.40
	12/94							233.97				
TF-6	10/30/88	313,837	430,480	90	90	202.7-150.2	235.20	236.85				
TF-7	10/30/88	314,013	429,731	58	58	38.8-53.8 ^{c/}		234.22	43.25	190.97		
	7/93										43.02	191.70
	12/94							234.36	44.42	189.94		
TF-8	10/30/88	313,731	429,719	57	57	38.7-53.7 ^{d/}		233.46	44.19	189.27		
	7/93										43.68	189.78
	12/94							233.58	45.91	187.67		
TF-11	7/93									191.43		
	12/94							233.63	43.94	189.59		

Source: ES, 1986; UNC Geotech, 1991; O'Brien and Gere, 1994 and 1995.

^{a/} PVC = polyvinyl chloride well casing.

^{b/} Feet btoc = feet below top of casing.

^{c/} Feet btoc.

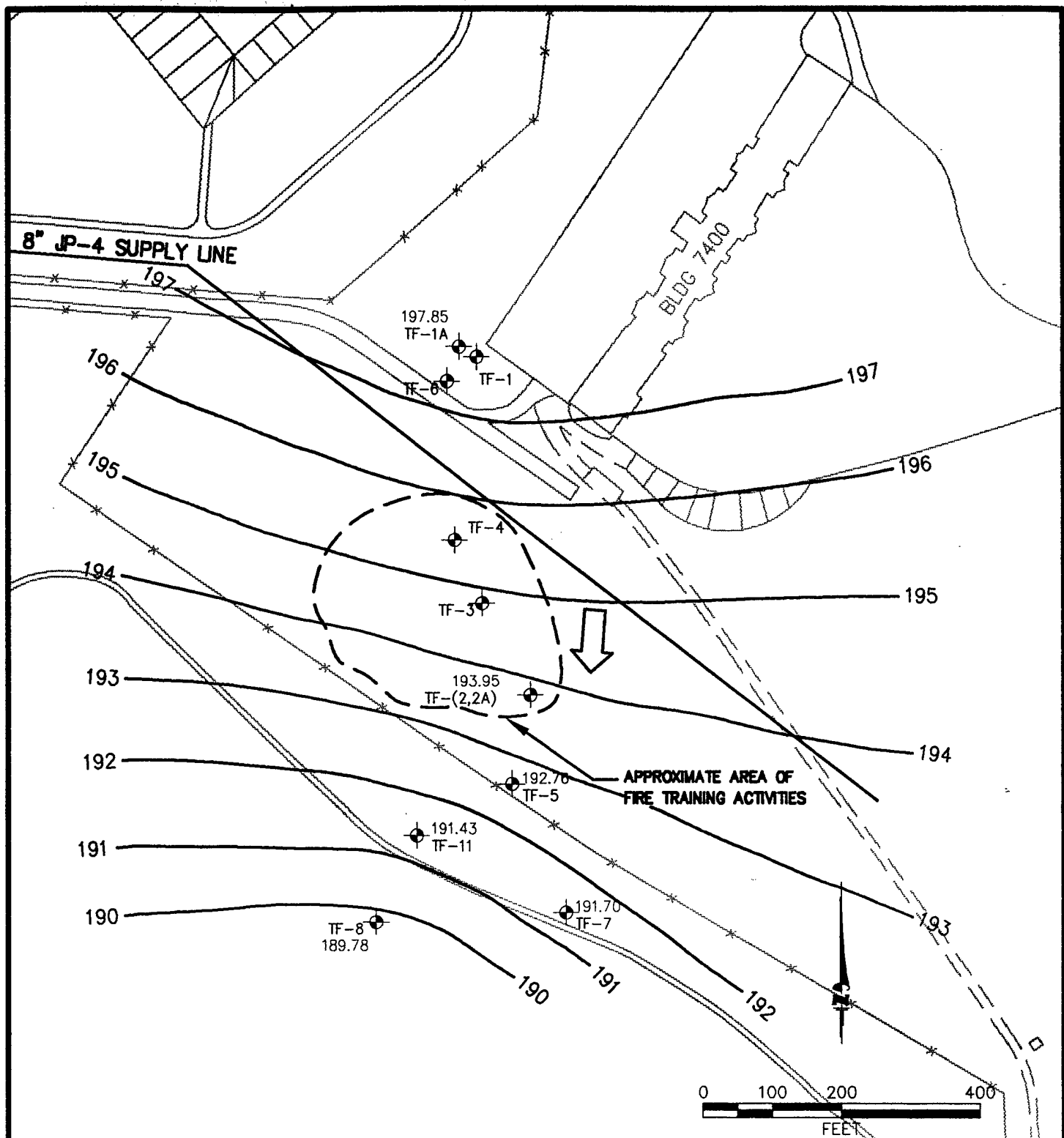

LEGEND

- 189.78
 TF-1 MONITORING WELL , WITH GROUNDWATER ELEVATION
- 190 LINE OF EQUAL GROUNDWATER ELEVATION (FEET msl)
- ← GROUNDWATER FLOW DIRECTION
- *-* FENCE

FIGURE 2.9
WATERTABLE ELEVATION
CONTOUR MAP
SITE FT-03, JULY 1993

 Intrinsic Remediation TS
 Westover ARB, Massachusetts

PARSONS
ENGINEERING SCIENCE, INC.
 Denver, Colorado

Source: O'Brien and Gere, 1994.

TABLE 2.4
TOLUENE SOIL GAS CONCENTRATIONS MEASURED AT SITE FT-08
INTRINSIC REMEDIATION TS
WESTOVER ARB, MASSACHUSETTS

Northing	Easting	Toluene (ppbv) ^{a/}	Northing	Easting	Toluene (ppbv)
800	0	25	500	400	7300
800	100	25	500	500	3950
800	200	25	500	600	25
800	300	25	450	50	25
800	400	25	450	150	25
800	500	25	450	250	230000
800	600	25	450	350	1900
750	50	25	450	450	471
750	150	25	450	550	25
750	250	25	400	0	231
750	350	25	400	100	335
750	450	25	400	200	25
750	550	25	400	300	25
700	0	25	400	400	25
700	50	25	400	500	25
700	100	127500	400	600	25
700	200	25	300	0	177
700	300	25	300	100	223
700	400	25	300	200	150
700	500	25	300	300	209
700	600	25	300	400	196
650	50	25	300	500	188
650	150	25	300	600	25
650	250	25	200	0	147
650	350	25	200	100	25
650	450	25	200	200	25
650	550	25	200	300	25
600	0	25	200	400	25
600	100	25	200	500	25
600	200	800	200	600	25
600	300	208	100	0	25
600	400	25	100	100	25
600	500	25	100	200	25
600	600	25	100	300	25
550	50	25	100	400	25
550	150	25	100	500	25
550	250	25	100	600	25
550	350	25	0	0	25
550	450	25	0	100	25
550	550	38600	0	200	25
500	20	25	0	300	25
500	100	481	0	400	25
500	200	69000	0	500	25
500	300	2100	0	600	25

Source: UNC Geotech, 1991.

^{a/} ppbv = parts per billion, volume per volume.

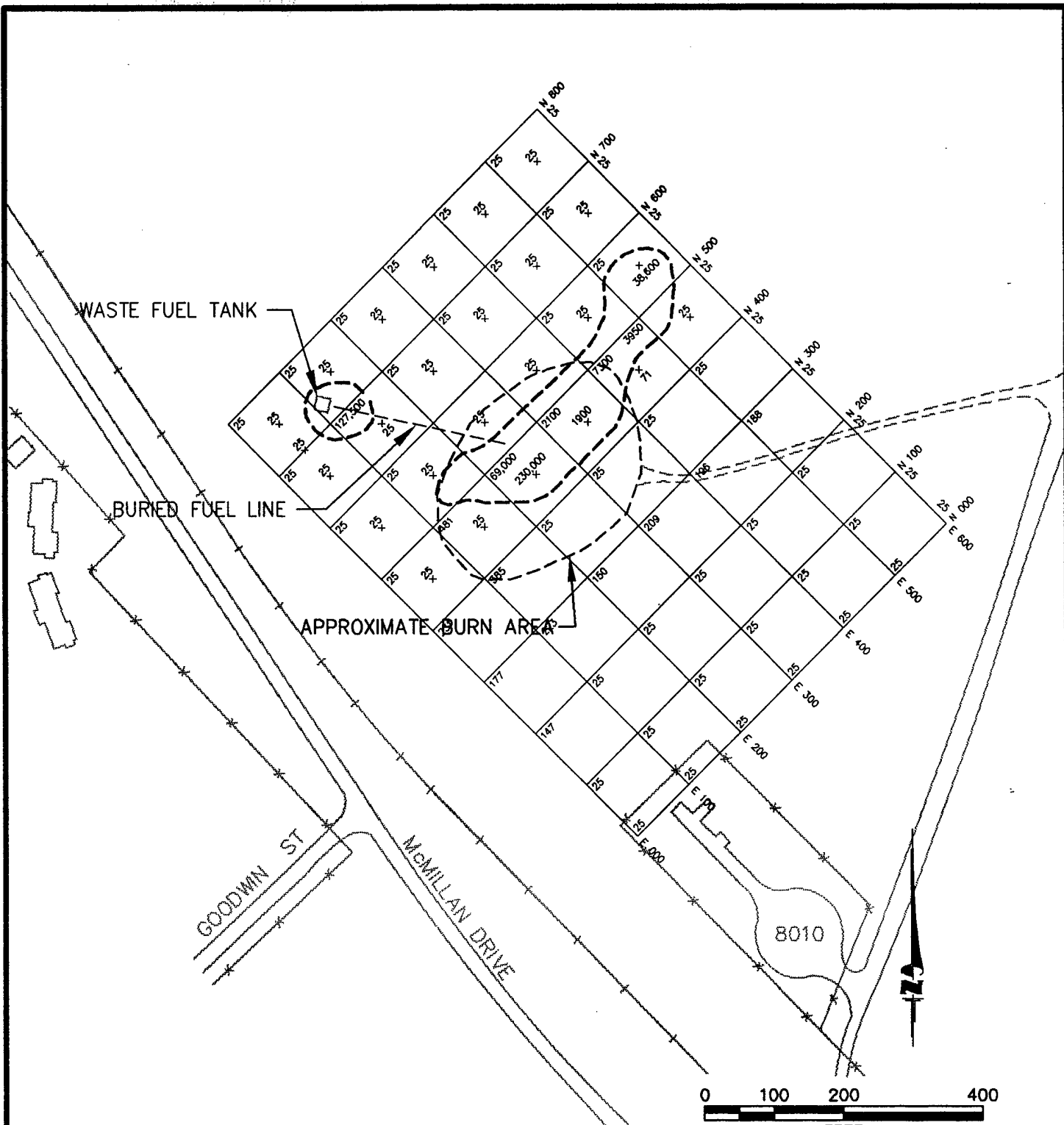

LEGEND



- 25 TOLUENE SOIL GAS CONCENTRATION(ppbv)
-  TOLUENE SOIL GAS CONCENTRATIONS GREATER THAN 2,000 ppbv
- N 000
E 600 SAMPLING GRID COORDINATES

FIGURE 2.10

CORRECTED TOLUENE SOIL GAS SAMPLING LOCATIONS AND CONCENTRATIONS SITE FT-08

Intrinsic Remediation TS
Westover ARB, Massachusetts

 **PARSONS ENGINEERING SCIENCE, INC.**

Denver, Colorado

Source: UNC Geotech, 1991(corrected by Parsons ES, 4/95)

fuel tank. The high soil gas toluene concentrations in the vicinity of the abandoned waste fuel tank may have resulted from tank leakage or from fuel and solvent spills during filling of the tank.

2.1.3.2 Soil Sampling

In 1986, ES drilled and sampled four shallow test borings to depths of 15 feet bgs and analyzed soil samples for halogenated and aromatic volatile organic compounds (VOC) and total petroleum hydrocarbons (TPH). UNC Geotech (1991) installed 17 soil borings using a hollow-stem auger drilling rig and 8 soil borings using a hand auger. Soil samples for laboratory analysis were collected from 19 of these boreholes. The samples were collected at various depths and analyzed for oil and grease, benzene, toluene, xylene, and a carbon-9 through carbon-32 scan. In 1993, 12 additional soil borings were installed by A&W Environmental Drilling under the direction of O'Brien and Gere Engineers. Split-spoon samples were collected from up to 10 feet bgs and screened in the field for organic vapors in accordance with the Massachusetts Department of Environmental Protection (DEP) Jar Headspace Analytical Sampling Procedure using a photoionization detector (PID). Surface samples (0-2 feet) were analyzed for gas chromatography/mass spectrometry (GC/MS) semi-volatile organic compounds (SVOC), GC/MS VOCs, inductively coupled plasma spectrometry (ICP) metals, graphite furnace lead, and soil moisture. Figure 2.11 and Tables 2.5A, 2.5B, and 2.5C are summaries of sampling locations and soil analytical data. A complete summary of analytical data from site FT-08 is presented in appendix B.

The analytical results for soil samples from the drilled soil borings and the hand-augered borings confirmed the results of the soil gas survey. The data indicate that BTEX, petroleum hydrocarbons, and chlorinated solvents are present at locations corresponding to the former waste fuel tank and the burn area. Earlier analytical results of contamination were difficult to interpret due to inconsistent data collection and reporting between the 1988 ES and the 1994 O'Brien and Gere investigations. Trichloroethene (TCE) was detected in the burn area at concentrations ranging from 2 to 6 milligrams per kilogram (mg/kg). Total BTEX concentrations of up to 440 mg/kg were detected in samples collected from the burn area. A BTEX concentration of 347 mg/kg was detected in a soil sample collected adjacent to the waste fuel tank. High BTEX concentrations in soil samples coincide with the locations of soil staining observed at the site. In general, the data indicate contamination in the burn area and the vicinity of the former waste tank.

2.1.3.3 Groundwater Sampling

During the Phase II, Stage 2 field investigations by ES (1988), two monitoring well pairs (CF-1,-1A and CF-2,-2A) were installed. Wells CF-1 and CF-1A were installed upgradient from FT-08. Wells CF-2 and CF-2A were installed within the burn area. Wells CF-3 and CF-4, also installed by ES, were placed in and northeast of the burn area, respectively. UNC Geotech (1991) installed monitoring wells CF-5, CF-6, and CF-7. CF-7 is a 4-inch pumping well upgradient of the Current Fire Training Area, near existing monitor well CF-1A, and was used as an observation well for the pumping test performed by UNC Geotech in 1991. In 1993, O'Brien and Gere (1994)

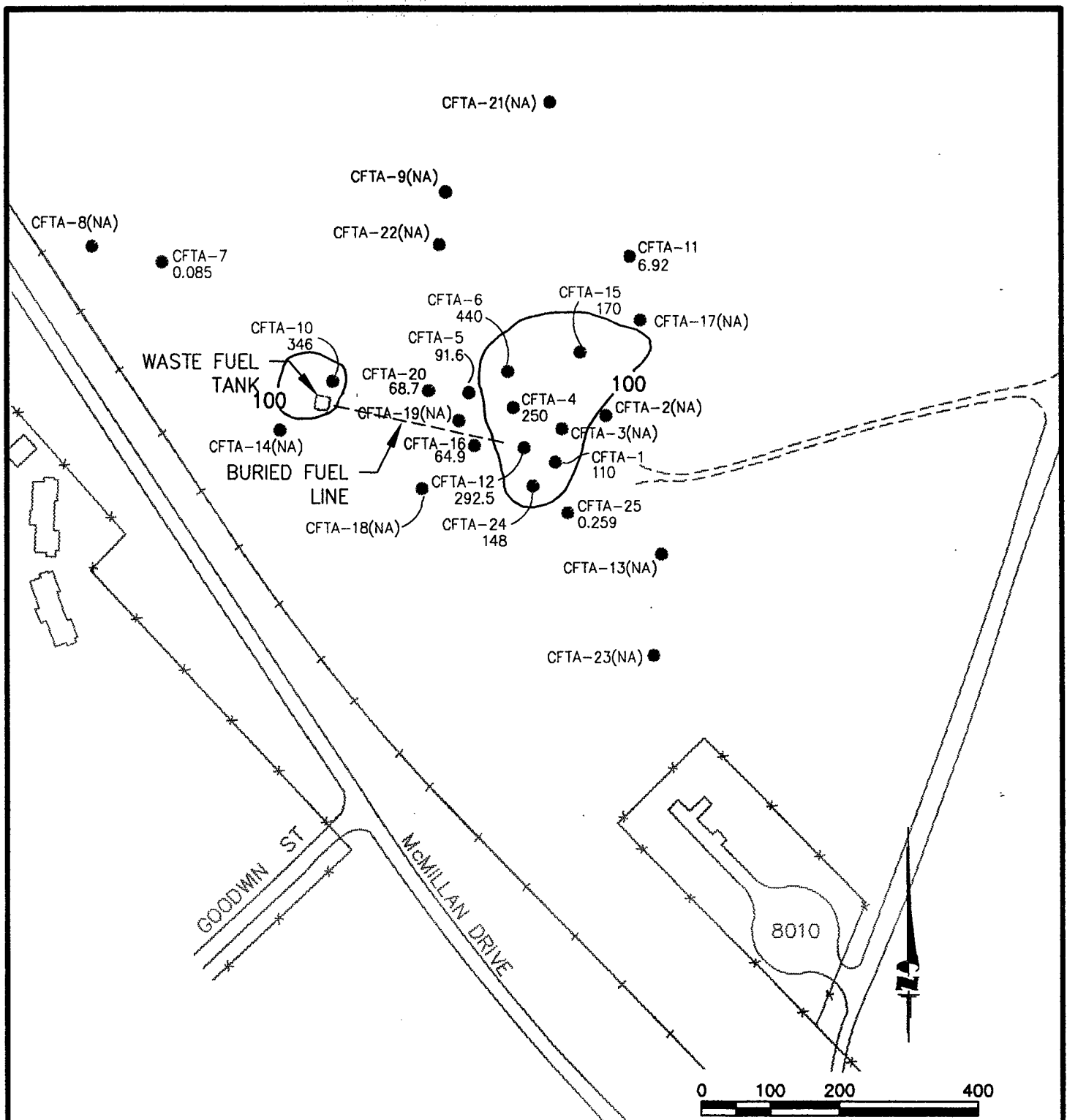

LEGEND

- 
 CFTA-10
346

UNC GEOTECH SOIL BORING AND
MAXIMUM TOTAL BTEX
CONCENTRATION (mg/kg)
- 

100
APPROXIMATE AREA OF TOTAL
BTEX CONCENTRATIONS
>100 mg/kg
- (NA) NOT ANALYZED

Source: UNC Geotech, 1991.

FIGURE 2.11

**LOCATIONS OF UNC GEOTECH
SOIL BORINGS AN MAXIMUM
TOTAL BTEX CONCENTRATIONS
SITE FT-08**

Intrinsic Remediation TS
Westover ARB, Massachusetts

 **PARSONS
ENGINEERING SCIENCE, INC.**

Denver, Colorado

TABLE 2.5 A
SUMMARY OF ES (1988) SOIL ANALYTICAL DATA
SITE FT-08
INTRINSIC REMEDIATION TS
WESTOVER ARB, MASSACHUSETTS

Location	Depth (feet bgs)	Benzene (mg/kg)	Toluene (mg/kg)	Ethylbenzene (mg/kg)	Total			TPH (mg/kg)	TCE (mg/kg)
					Xylenes (mg/kg)	BTEX (mg/kg)			
CFS-1	1	ND ^{a/}	19	ND	ND	19	76000	ND	
	3	13	1.3	ND	ND	14.3	560	ND	
	5	10	ND	ND	ND	10	1800	ND	
	10	6	ND	ND	ND	6	ND	ND	
	15	8.5	1.1	ND	ND	9.6	ND	ND	
CFS-2	1	16	1.8	ND	ND	17.8	ND	ND	
	3	14	ND	ND	ND	14	43000	ND	
	5	14	1.7	ND	ND	15.7	ND	ND	
	10	ND	ND	ND	ND	ND	ND	ND	
	15	84	6.2	ND	ND	90.2	ND	ND	
20	ND	ND	ND	ND	ND	ND	ND		
CFS-3	1	ND	ND	ND	ND	ND	ND	ND	
	3	ND	ND	ND	ND	ND	ND	ND	
	5	ND	ND	ND	ND	ND	ND	ND	
	10	ND	ND	ND	ND	ND	520	ND	
	15	ND	ND	ND	ND	ND	740	ND	
CF	1	ND	ND	ND	ND	ND	102000	ND	
	3	ND	ND	ND	ND	ND	1200	ND	
	5	ND	ND	ND	ND	ND	850	ND	
	10	ND	ND	ND	ND	ND	440	ND	
	15	ND	ND	ND	ND	ND	ND	ND	

Source: ES, 1988.

^{a/}ND = Compound not detected.

TABLE 2.5 B
 SUMMARY OF UNC GEOTECH (1991) SOIL ANALYTICAL DATA^{a/}
 SITE FT-08

INTRINSIC REMEDIATION TS
 WESTOVER ARB, MASSACHUSETTS

Sample Identification	Depth (feet bgs)	Benzene (mg/kg)	Toluene (mg/kg)	Ethylbenzene (mg/kg)	Total Xylenes (mg/kg)	Total BTEX (mg/kg)	Kerosene (mg/kg)	Oil and Grease (mg/kg)
CFTA-1	0	NA ^{b/}	NA	NA	NA	NA	550	610
	3	NA	NA	10	100	110	NA	15400
	5	NA	NA	3.7	46	49.7	NA	7060
CFTA-4	3	NA	57	26	140	223	NA	12400
	3.5	NA	48	20	82	150	NA	NA
	5	2	57	31	160	250	NA	6030
	5.5	NA	91	41	NA	132	NA	NA
CFTA-5	0	NA	0.12	NA	NA	0.12	NA	NA
	3	NA	1.6	2	88	91.6	NA	620
	5	NA	6.1	3	71	80.1	NA	3460
CFTA-6	0	NA	0.054	NA	NA	0.054	NA	NA
	2.5	NA	80	37	200	317	NA	NA
	3	NA	130	40	270	440	NA	10100
	5	NA	24	12	78	114	NA	3760
CFTA-7	0	NA	0.085	NA	NA	0.085	NA	NA
CFTA-9	0	NA	NA	NA	NA	NA	NA	230
	10	NA	NA	NA	NA	NA	NA	60
CFTA-10	5	3.7	100	33	210	346.7	NA	13000
	10	0.058	0.39	0.23	2.4	3.078	58	580
CFTA-11	0	NA	NA	NA	NA	NA	NA	380
	5	NA	NA	0.92	6	6.92	NA	NA
	10	NA	0.24	NA	0.35	0.59	NA	NA
CFTA-12	0	2.5	120	20	150	292.5	NA	12000
	5	NA	120	22	150	292	NA	10000
	10	NA	0.11	NA	1.2	1.31	69	160

TABLE 2.5 B (CONTINUED)
 SUMMARY OF UNC GEOTECH (1991) SOIL ANALYTICAL DATA^{a/}
 SITE FT-08

INTRINSIC REMEDIATION IS
 WESTOVER ARB, MASSACHUSETTS

Sample Identification	Depth (feet bgs)	Benzene (mg/kg)	Toluene (mg/kg)	Ethylbenzene (mg/kg)	Total Xylenes (mg/kg)	Total BTEX (mg/kg)	Kerosene (mg/kg)	Oil and Grease (mg/kg)
CFTA-13	5	NA	NA	NA	NA	NA	6.5	NA
CFTA-15	0	NA	32	7.8	94	133.8	16000	30000
	2	NA	47000	13	110	47123	NA	21000
	4	NA	23	8.3	53	84.3	NA	8200
	6	NA	NA	NA	NA	NA	NA	190
CFTA-16	0	0.14	8	5.1	32	45.24	NA	130
	5	0.2	13	6.7	45	64.9	NA	1800
	10	NA	0.12	NA	0.44	0.56	NA	NA
CFTA-17	0	NA	NA	NA	NA	NA	NA	NA
CFTA-18	0	NA	NA	NA	NA	NA	NA	NA
CFTA-20	5	NA	14	9.7	45	68.7	3300	7800
	10	NA	0.74	0.16	0.9	1.8	13	60
CFTA-22	0	NA	NA	NA	NA	NA	NA	NA
	10	NA	NA	NA	NA	NA	NA	NA
CFTA-23	0	NA	NA	NA	NA	NA	NA	NA
CFTA-24	0	NA	10	2.9	33	45.9	5400	1000
	5	NA	48	18	82	148	3800	7200
	10	NA	0.11	NA	0.25	0.36	120	220
	15	0.16	0.94	0.14	0.79	2.03	13	
CFTA-25	10	0.069	0.19	NA	NA	0.259	NA	NA

Source: UNC Geotech, 1991.

^{a/} Values are the maximum sample concentrations at given depth.

^{b/} NA = Information is not available.

TABLE 2.5 C
SUMMARY OF O'BRIEN AND GERE (1994) SOIL ANALYTICAL DATA
SITE FT-08
INTRINSIC REMEDIATION TS
WESTOVER ARB, MASSACHUSETTS

Location	Depth (feet bgs)	Benzene (µg/kg)	Toluene (µg/kg)	Ethylbenzene (µg/kg)	Total		TCE (µg/kg)
					Xylenes (µg/kg)	BTEX (µg/kg)	
1+0-600R	0-2	ND ^{a/}	ND	ND	ND	ND	6 U ^{b/}
2+0-600R	0-2	ND	ND	ND	0.92 J ^{c/}	0.92	5.3 U
3+0-600R	0-2	ND	ND	ND	ND	ND	6.1 U
4+0-600R	0-2	ND	ND	ND	ND	ND	6.2 U
0+0-400R	0-2	ND	ND	ND	ND	ND	7.6 U
1+0-400R	0-2	ND	ND	ND	ND	ND	3.8 J
2+0-400R	0-2	ND	ND	ND	ND	ND	6.1 J
3+0-400R	0-2	0.74 J	4.2 J	ND	ND	4.9	5.6 UJ
4+0-400R	0-2	ND	3 J	ND	1.3 J	4.3	5.4 J
0+0-500R	0-2	ND	ND	ND	ND	ND	1.8 J
1+0-500R	0-2	ND	ND	ND	1.4 J	1.4	0.88 J
2+0-500R	0-2	ND	ND	ND	ND	ND	6 U

Source: O'Brien and Gere, 1994.

^{a/} ND = Compounds not detected.

^{b/} U = Compound not detected.

^{c/} J = Result is below the reporting limit or is an estimated concentration.

installed monitoring well CF-8. At the time O'Brien and Gere developed CF-8, they redeveloped wells CF-2 through CF-7.

Groundwater samples were collected in 1986, 1991, and 1993, and analyzed by one or more of the following methods: BTEX, TPH, ICP metals, total dissolved solids, VOCs, SVOCs. A summary of the laboratory analytical results for the groundwater samples is presented in Table 2.6. Figure 2.12 is a map of Site FT-08 depicting monitoring well locations and BTEX contamination levels.

The highest BTEX concentrations were detected in groundwater samples collected at wells CF-2A and CF-3, with reported concentrations of 5,400 and 6,850 micrograms per liter ($\mu\text{g/L}$), respectively. Both wells are located within the burn area. A TCE concentration of 11,000 $\mu\text{g/L}$ was also observed in a sample from well CF-3. Total BTEX and TCE concentrations have not exceeded 10 $\mu\text{g/L}$ in groundwater samples from any other Site FT-08 wells. BTEX and TCE were not detected in groundwater samples collected from the three upgradient wells.

The groundwater BTEX results correspond fairly well with the results of the soil gas and soil sampling. The data suggest that the plume originates in and is generally confined to the burn area. Given the estimated site groundwater velocity, there has been adequate time for the plume to reach CF-8, the furthest downgradient well. However, VOC concentrations were not detected in the groundwater sample collected from this well. A sample from well CF-6, located less than 200 feet downgradient from the burn pit, had concentrations of 1.4 $\mu\text{g/L}$ total BTEX and 1.5 $\mu\text{g/L}$ TCE. Contamination also appears to be confined to the shallow groundwater zones. Groundwater in the deep monitoring well CF-2 has not contained contaminants detected in the adjacent shallow groundwater well CF-2A.

2.1.3.4 Electrical Resistivity Surveys

In 1986 ES (1988) performed a series of soil electrical resistivity (ER) surveys at FT-08. The FT-08 surveys were interpreted with and correlated to well logs and other site information. The data suggest that areas of low soil resistivity may be the result of groundwater contamination. The ER profile contour map for the 25-foot sounding illustrates soil ER values of 500 Ohm-feet in the center of the burn area, and a triangular anomaly of 1,000 Ohm-feet surrounding the burn area (Figure 2.13). The areas of low resistivity extend in a southeasterly, direction which may indicate a contaminant plume migrating in that direction. Deeper soundings produced similar results (ES, 1988). A 30-foot sounding performed near the buried fuel line and abandoned waste fuel tank did not identify abnormal ER signatures (ES, 1988).

2.1.4 Summary of Analytical Results for Site FT-03

2.1.4.1 Soil Gas Survey

UNC Geotech (1991) conducted a toluene soil gas survey for their RI/FS report using a gas chromatograph to analyze 56 soil samples collected over a 300- by 600-foot grid (Table 2.7). Figure 2.14 shows the UNC Geotech (1991) soil gas results

TABLE 2.6
 SUMMARY OF GROUND WATER ANALYTICAL DATA
 SITE FT-08
 INTRINSIC REMEDIATION IS
 WESTOVER ARB, MASSACHUSETTS

Location	Sampling Event	Benzene (µg/L)	Toluene (µg/L)	Ethylbenzene (µg/L)	Xylenes (µg/L)	Total BTEX (µg/L)	Petroleum Hydrocarbons (mg/l)	TCE (µg/L)	1,1,2,2-Tetrachloroethane (µg/L)	Naphthalene (µg/L)	TDS ^{a/} (mg/L)
CF-1	1986: R-1	ND ^{b/}	ND	ND	ND	ND	120	1.1 ^{c/}	ND	NA	99
	R-2	ND	ND	ND	ND	ND	4	ND	ND	NA	58
CF-1A	1986: R-1	ND	ND	ND	ND	ND	20	0.32 ^{c/}	0.06	NA	146
	R-2	ND	ND	ND	ND	ND	3	ND	ND	NA	150
CF-2	1993	ND	ND	ND	ND	ND	NA ^{d/}	ND	ND	ND	183
	1986: R-1	ND	0.23	ND	ND	0.23	69	0.23 ^{c/}	ND	NA	97
CF-2A	R-2	ND	ND	ND	ND	ND	3	ND	ND	NA	69
	1986: R-1	4.3	ND	ND	ND	4.3	50	ND	ND	NA	464
	R-2	800	1800	250	ND	2850	110	ND	ND	NA	554
	R-3	1400	4000 ^{e/}	ND	ND	5400	NA	230	3.5 ^{e/}	NA	NA
CF-3	1991	180	110	86	310	686	NA	ND	ND	22	360
	1991	280	2600	770	3200	6850	NA	11000	ND	70	80
	1993	200 J	2,000	440	2,300	4,740	NA	5,400	ND	26	115
	1986: R-1	ND	1,200	ND	ND	1,200	190	5400 ^{e/}	ND	NA	146
CF-4	R-2	ND	3,600	730	ND	4,330	32	ND	ND	NA	115
	R-3	ND	2800 ^{c/}	ND	ND	2800	NA	ND	6.9 ^{e/}	NA	NA
	1993	ND	ND	ND	ND	ND	NA	ND	ND	ND	1020
CF-5	1986: R-1	ND	ND	ND	ND	ND	82	0.98 ^{c/}	ND	NA	88
	R-2	ND	ND	ND	ND	ND	4	ND	ND	NA	60
	R-3	ND	ND	ND	ND	ND	NA	ND	0.1	NA	NA
CF-6	1993	4.9 J ^{f/}	ND	1.1 J	2.4 J	8.4 J	NA	ND	ND	ND	84
	1993	1.4 J	ND	ND	ND	1.4 J	NA	1.5 J	ND	ND	53
CF-7	1993	ND	ND	ND	ND	ND	NA	ND	ND	ND	55 J
	1993	ND	ND	ND	ND	ND	NA	ND	ND	ND	52

TABLE 2.6 (Continued)
 SUMMARY OF GROUND WATER ANALYTICAL DATA
 SITE FT-08

INTRINSIC REMEDIATION TS
 WESTOVER ARB, MASSACHUSETTS

Location	Sampling Event	Dissolved				Redox			Conductivity (µmhos/cm)	pH	TDS (mg/L)
		Oxygen (mg/L)	Nitrite (mg/L)	Nitrate (mg/L)	SO ₄ (mg/L)	Potential (mV)	Alkalinity (mg/L)				
CF-1	1991	0.25	ND	ND	14.1	104	34	84.7	6.9	70	
CF-1A	1991	7	ND	0.1	10	355	16	39.3	5.56	40	
CF-2	1991	0.25	ND	ND	9.8	128	22	68.8	7.05	70	
CF-2A	1991	3.1	ND	ND	12.8	182	310	532	6.47	360	
CF-3	1991	1.6	ND	ND	2.4	174	82	144	5.72	80	
CF-4	1991	8	ND	ND	12.6	440	30	69.5	5.71	50	
CF-5	1991	3.9	ND	0.8	32.5	470	2	102.3	4.76	90	
CF-6	1991	4.6	ND	20.7	25.6	527	10	116.7	4.8	70	
CF-6A	1991	0.55	ND	ND	9.9	199	35	69.9	6.45	60	

Source: ES, 1988; UNC Geotech, 1991; O'Brien and Gere, 1993 and 1994.

^{a/} TDS = total dissolved solids.

^{b/} ND = Data not detected.

^{c/} Compound also present in laboratory blank.

^{d/} NA = Data not available.

^{e/} Compound detected in first chromatograph column, could not be confirmed by second column.

^{f/} J = Result is below reporting limit or is an estimated concentration.

CF-1	BTEX	TCE
1991	ND	ND
1986-R2	ND	ND
1986-R1	ND	1.1

	BTEX	TCE
1993	ND	ND

	BTEX	TCE
1993	4740	5400
1991	6850	11000
1986-R3	2800	ND
1986-R2	4330	ND
1986-R1	1200	5400

	BTEX	TCE
1993	ND	ND
1996-R3	ND	ND
1986-R2	ND	ND
1986-R1	ND	0.98

CF-1A	BTEX	TCE
1986-R2	ND	ND
1986-R1	ND	0.32

	BTEX	TCE
1993	8.4 J	ND



CF-2A	BTEX	TCE
1991	686	ND
1986-R3	5400	230
1986-R2	2850	ND
1986-R1	4.3	ND

	BTEX	TCE
1993	ND	ND

CF-2	BTEX	TCE
1993	ND	ND
1986-R2	ND	ND
1986-R1	0.23	0.23

	BTEX	TCE
1993	1.4 J	1.5 J

LEGEND

-  GROUNDWATER FLOW DIRECTION
-  MONITORING WELL LOCATION
- ND NOT DETECTED
- NA NOT ANALYZED
- J ESTIMATED VALUE

NOTE:

GIVEN CONCENTRATIONS ARE MAXIMUMS FROM EACH SAMPLING ROUND AND DO NOT INCLUDE SAMPLES WITH SUSPECTED LABORATORY CONTAMINATION.

CONCENTRATIONS REPORTED IN $\mu\text{g/L}$

Source: ES, 1988; UNC Geotech, 1991; and O'Brien and Gere, 1994.



**FIGURE 2.12
GROUNDWATER BTEX
AND
TCE CONCENTRATIONS
SITE FT-08**

Intrinsic Remediation TS
Westover ARB, Massachusetts

 **PARSONS
ENGINEERING SCIENCE, INC.**

Denver, Colorado

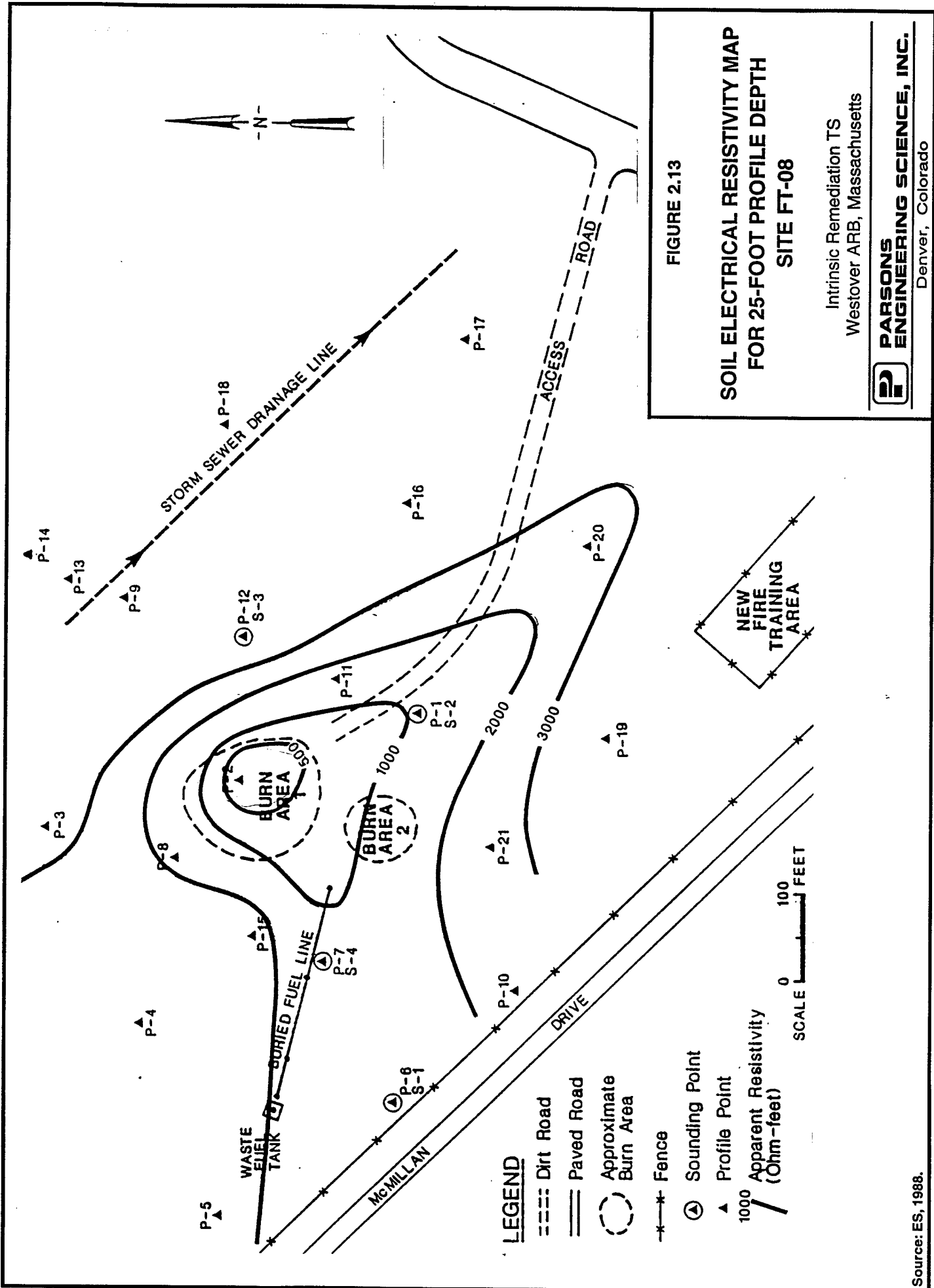

FIGURE 2.13

**SOIL ELECTRICAL RESISTIVITY MAP
FOR 25-FOOT PROFILE DEPTH
SITE FT-08**

Intrinsic Remediation TS
Westover ARB, Massachusetts



**PARSONS
ENGINEERING SCIENCE, INC.**
Denver, Colorado

LEGEND

- Dirt Road
- == Paved Road
- Approximate Burn Area
- *- Fence
- ⊙ Sounding Point
- ▲ Profile Point
- 1000 / Apparent Resistivity (Ohm-feet)

SCALE 0 100 FEET

TABLE 2.7
TOLUENE SOIL GAS CONCENTRATIONS MEASURED AT SITE FT-03
INTRINSIC REMEDIATION TS
WESTOVER ARB, MASSACHUSETTS

Northing	Easting	Toluene (ppbv)	Northing	Easting	Toluene (ppbv)
50	700	51	100	850	93000
100	700	83	150	850	25
150	700	52	200	850	26
200	700	25	250	850	25
250	700	140	300	850	25
300	700	53	350	850	25
350	700	49	400	850	39
400	700	25	0	900	2030
25	750	33	50	900	850
50	750	133	100	900	67000
100	750	35	150	900	208
150	750	28	200	900	52
200	750	105	250	900	25
250	750	58	300	900	26
300	750	36	350	900	728
350	750	105	400	900	3580
400	750	25	250	950	25
0	800	52	300	950	221
50	800	369	350	950	25
100	800	49	400	950	25
150	800	64	0	1000	25
200	800	16400	50	1000	25
250	800	17200	100	1000	26
300	800	33	150	1000	4100
350	800	49	200	1000	25
400	800	179	250	1000	101
0	850	37	300	1000	25
50	850	72	375	1000	25

Source: UNC Geotech, 1991.

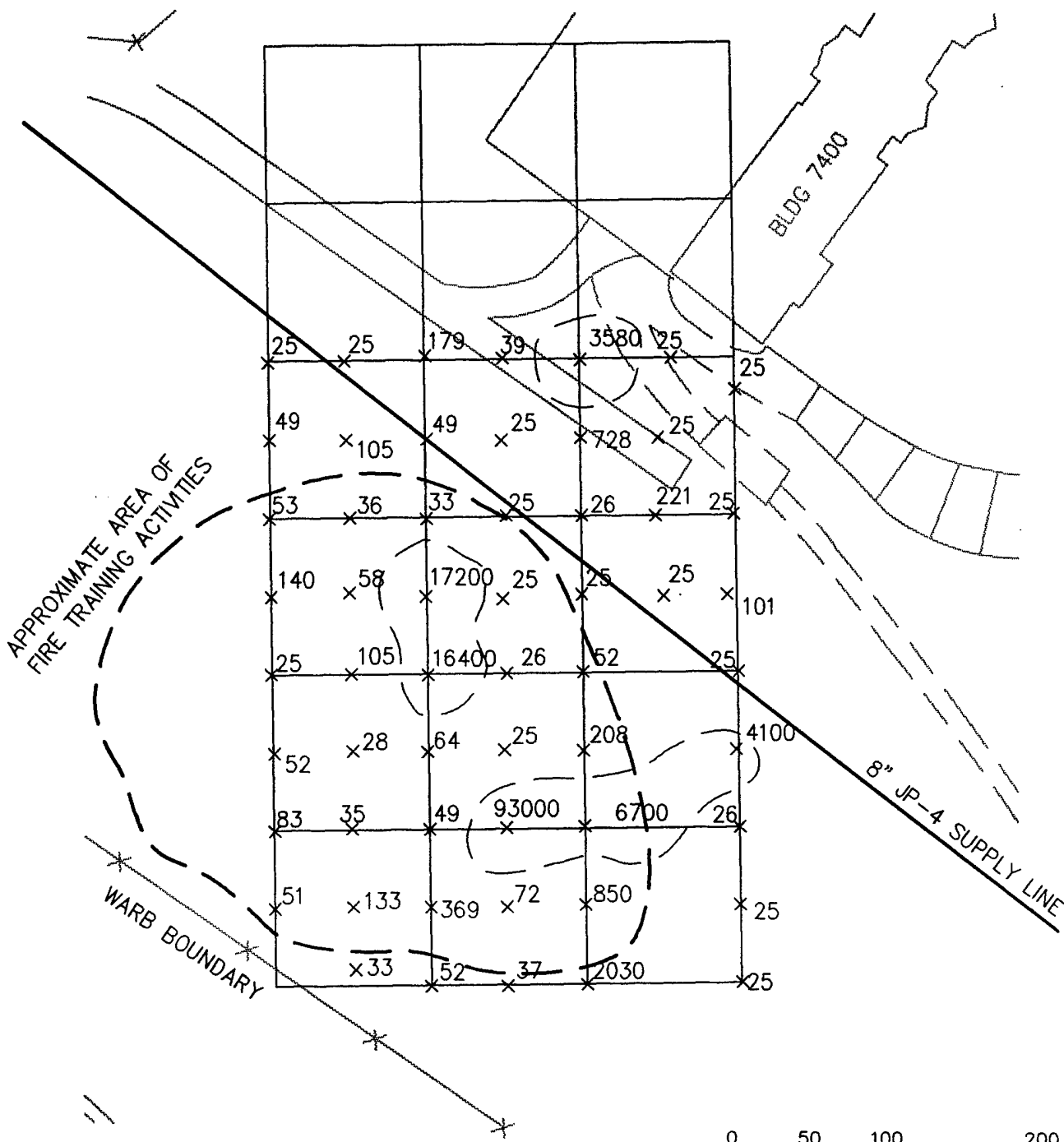

LEGEND

- x³³ TOLUENE SOIL GAS CONCENTRATION
- () AREA OF TOLUENE SOIL GAS CONCENTRATIONS GREATER THAN 2,000 ppbv



FIGURE 2.14
TOLUENE SOIL GAS SAMPLING LOCATIONS AND CONCENTRATIONS
SITE FT-03

Intrinsic Remediation TS
 Westover AFRES, Massachusetts

PARSONS ENGINEERING SCIENCE, INC.
 Denver, Colorado

SOURCE: UNC Geotech, 1991.

reproduced on an O'Brien and Gere (1994) site map for FT-03. This was required because the Site FT-03 figures in the UNC Geotech report were produced using an inaccurate scale. High concentrations of toluene (greater than 2,000 ppbv) were found in three areas of the site. The locations of high toluene soil gas correspond with locations where fire training activities were conducted. The highest toluene soil gas concentration was 93,000 ppbv in the southern portion of the site (Figure 2.14). In general, the area and concentrations of toluene soil gas contamination are smaller than at FT-08.

2.1.4.2 Soil Sampling

In 1986, ES (1988) placed three soil borings to depths of 15 feet bgs and analyzed soil samples for halogenated and aromatic VOCs. UNC Geotech (1991) installed an additional 19 soil borings using a hollow-stem auger drill rig and a hand auger. The samples were analyzed for oil and grease, benzene, toluene, xylene, and a kerosene-range (C9-C32) organic scan. In 1993, 13 soil borings were installed by A&W Environmental Drilling under the direction of O'Brien and Gere Engineers (1994). Split spoon samples were collected from 0 to 2 feet, 3 to 5 feet, 8 to 10 feet, 18 to 20 feet bgs, and at the top of the saturated zone approximately 38 to 40 feet bgs. The samples were screened in the field for organic vapors. Zero- to 2-foot and 18- to 20-foot samples were analyzed in a laboratory for GC/MS SVOCs, GC/MS VOCs, ICP metals, graphite furnace lead, organochlorine pesticides, Polychlorinated-biphenyls (PCB), TPH, nitrogen, ammonia, and soil moisture. A 8- to 10-foot soil sample was taken from 8 to 10 feet bgs near the underground jet fuel pipeline and analyzed for VOCs and TPH because it exhibited staining and elevated organic vapor readings.

FT-08 soil sampling data from the ES (1988) and UNC Geotech (1991) reports were not available at the time this document was produced; however, the 1993 and 1994 O'Brien and Gere soil analytical data are summarized in Table 2.8. O'Brien and Gere (1994) analytical results did not identify significant soil contamination within the burn area or topographically downgradient in Chicopee Memorial State Park. Only one elevated BTEX concentration was detected in soil samples collected during the 1993 and 1994 investigations. Total BTEX was detected at 3.5 mg/kg in a sample from 8 to 10 feet bgs sample from boring SB-9. This boring was located south of the underground jet fuel pipeline north of the burn area. Upon further review, O'Brien and Gere (1994) assumed on the basis of boring location and the observed conditions that the contamination is not associated with FT-03.

Studies at FT-03 prior to the O'Brien and Gere (1994) investigation have, however, identified oil and grease and petroleum-related compounds in shallow soil from the burn area. Contamination was reported to be present in soils from the surface to a depth of up to 10 feet bgs. Oil and Grease data are presented in Figure 2.15. The area of elevated oil and grease contamination corresponds to the burn area and the area of elevated toluene soil gas concentrations.

TABLE 2.8
 SUMMARY OF SOIL ANALYTICAL DATA
 INTRINSIC REMEDIATION TS
 SITE FT-03
 WESTOVER ARB, MASSACHUSETTS

Sample Identification	Depth (feet bgs)	Benzene (µg/kg)	Toluene (µg/kg)	Ethylbenzene (µg/kg)	Xylenes (µg/kg)	Total					TPH (mg/kg)
						BTEX (µg/kg)	TCE (µg/kg)	Tetrachloroethene (µg/kg)	1,2-DCE ^{d/} (µg/kg)		
SB-1	0-2	1.2 JB ^{b/}	ND ^{d/}	ND	1.6 JB	2.8 JB	ND	2.7 JB	1.2 JB	9.8 JB	
	18-20	ND	ND	ND	ND	ND	ND	ND	ND	6.6 JB	
SB-2	0-2	ND	ND	ND	ND	ND	ND	ND	ND	16 JB	
	18-20	ND	ND	ND	ND	ND	ND	ND	ND	3.5 JB	
SB-3	0-2	ND	ND	ND	ND	ND	ND	ND	ND	6.4 JB	
	18-20	ND	ND	ND	ND	ND	ND	ND	ND	6.6 JB	
SB-4	0-2	ND	ND	ND	ND	ND	ND	ND	ND	6.4 JB	
	18-20	ND	ND	ND	ND	ND	ND	ND	ND	6.1 JB	
SB-5	0-2	ND	ND	ND	ND	ND	ND	ND	ND	4.4 JB	
	18-20	ND	ND	ND	ND	ND	ND	ND	ND	2.6 JB	
SB-6	0-2	ND	ND	ND	ND	ND	ND	ND	ND	4.2 JB	
	18-20	ND	ND	ND	ND	ND	ND	ND	ND	3.4 JB	
SB-7	0-2	ND	ND	ND	ND	ND	ND	ND	ND	87	
	18-20	ND	0.6 J ^{d/}	ND	1.1 J	1.7 J	ND	ND	ND	5.8 JB	
SB-8	0-2	ND	ND	ND	ND	ND	ND	ND	ND	18 JB	
	18-20	ND	1.2 J	ND	ND	1.2 J	ND	ND	ND	7.3 JB	
SB-9	0-2	ND	ND	ND	ND	ND	ND	ND	ND	5.7 JB	
	8-10	ND	ND	ND	3500.0	3500.0	ND	ND	ND	1300	
	18-20	ND	ND	ND	ND	ND	ND	ND	ND	27 JB	
SB-10	0-2	ND	ND	ND	ND	ND	ND	ND	ND	5.8 JB	
	18-20	ND	ND	ND	ND	ND	ND	ND	ND	6.1 JB	
SB-11	0-2	ND	ND	ND	ND	ND	ND	ND	ND	64	
	18-20	ND	ND	ND	ND	ND	ND	ND	ND	15 JB	
SB-12	0-2	ND	ND	ND	ND	ND	ND	ND	ND	87	
	18-20	ND	ND	ND	ND	ND	ND	ND	ND	13 JB	
SB-13	0-2	ND	ND	ND	ND	ND	ND	ND	ND	28 JB	
	18-20	ND	ND	ND	ND	ND	ND	ND	ND	9.9 JB	

Source: O'Brien and Gere, 1994.

^{a/} 1,2 - DCE = 1,2 - dichloroethene.

^{b/} JB = Sample result is approximate and may reflect blank contamination.

^{c/} ND = Not Detected.

^{d/} J = Result is detected below the reporting limit or is an estimated concentration.

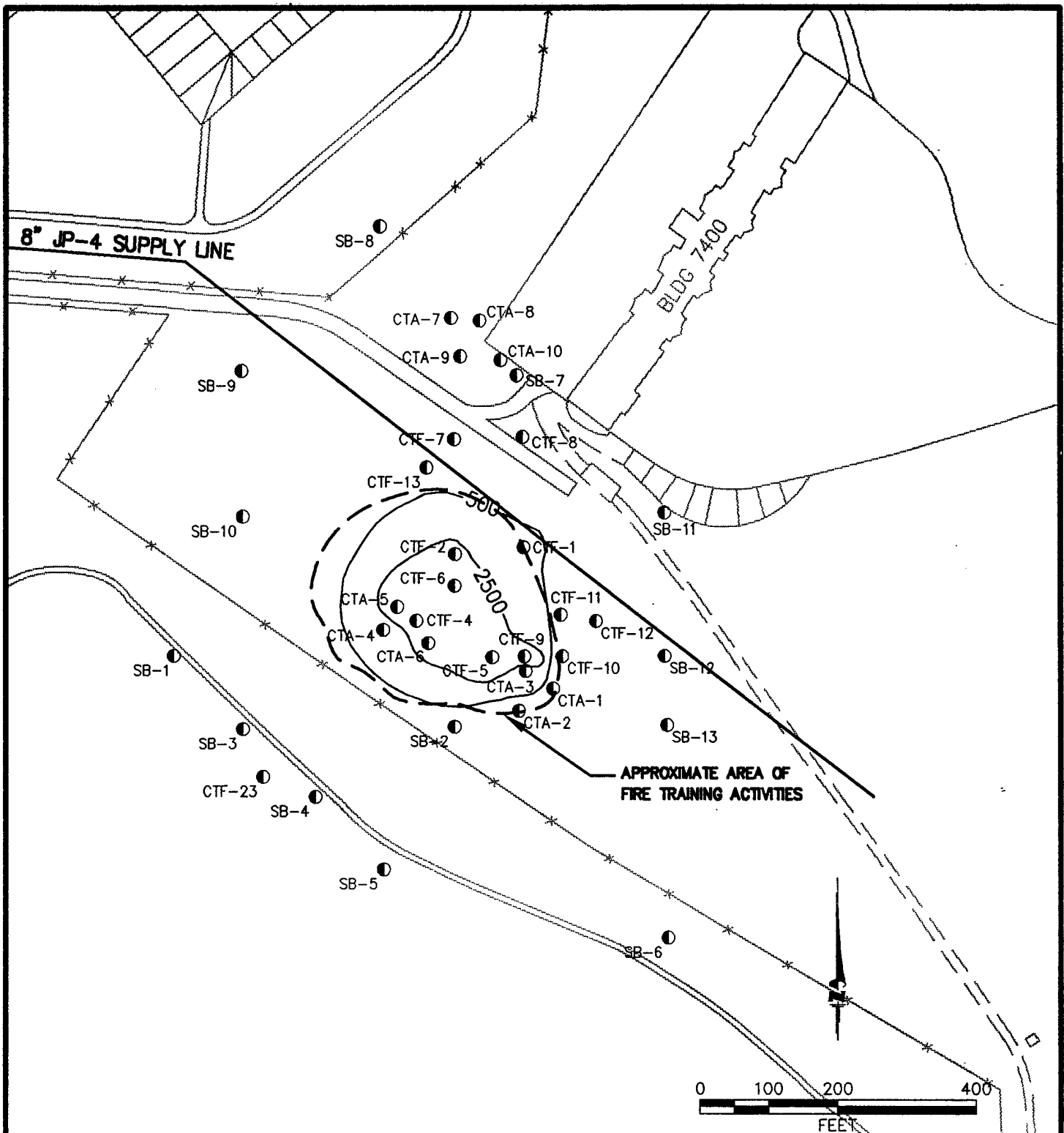

LEGEND

- SB-1 ● SOIL BORING LOCATION
- 500— OIL AND GREASE (mg/kg)
- *-*- FENCE



FIGURE 2.15

CONTOUR MAP OF TOTAL OIL AND GREASE IN SOIL SITE FT-03

Intrinsic Remediation TS
Westover ARB, Massachusetts

PARSONS ENGINEERING SCIENCE, INC.

Denver, Colorado

Source: O'Brien and Gere, 1994.

2.1.4.3 Site FT-03 Groundwater

As part of the field investigations for the 1988 ES report, 6 monitoring wells (TF-1, TF-1A, TF-2, TF-2A, TF-3, and TF-4) were installed and two rounds of groundwater samples were collected. The groundwater samples were analyzed for purgeable aromatics, purgeable halocarbons, and TPH. UNC Geotech (1991) installed two groundwater monitoring wells, TF-5 and TF-6, at FT-03, and two additional groundwater monitoring wells, TF-7 and TF-8, south of the Base in Chicopee Memorial State Park. Groundwater samples from the new and existing wells were analyzed for VOCs, SVOCs, inorganic compounds, metals, and total dissolved solids. In 1993, A&W Environmental Drilling under the direction of O'Brien and Gere, installed one monitoring well, TF-11, to further define the downgradient edge of the contaminant plume (O'Brien and Gere, 1994). Groundwater samples were collected from TF-1A, -2A, -5, -7, -8, and -11, and analyzed for total dissolved solids, GC/MS SVOCs, GC/MS VOCs, ICP metals, graphite furnace lead, organochlorine pesticides, PCBs, TPH, and nitrogen-ammonia. Groundwater sampling results from the ES (1988) and UNC Geotech (1991) reports were not available at the time this document was produced; however, the 1993 and 1994 O'Brien and Gere groundwater results are presented in Table 2.9 and on Figure 2.16.

The highest concentrations of total BTEX and chlorinated solvents have been consistently detected in groundwater samples from well TF-2A, a shallow well located near the center of the burn area. In 1993, the total BTEX concentration was 2,690 µg/L; however, the concentration decreased to 640.6 µg/l in 1994. Chlorinated solvent concentrations [composed entirely of 1,2-dichloroethene (DCE)] also decreased from 44 µg/L to 26 µg/L between the 1993 and 1994 sampling events. Four downgradient wells (TF-5, TF-7, TF-8, and TF-11) were sampled in 1993 and 1994. Total BTEX was detected in all four 1993 groundwater samples, and in all 1994 groundwater samples except those collected from TF-7 and TF-8. These two wells are located the furthest downgradient from the former burn area, at Chicopee Memorial State Park. Chlorinated solvents were detected in all 1993 and 1994 samples from three of the four downgradient wells, TF-5, -8, and -11. The data indicate that the plume extends toward the Chicopee Memorial State Park, and that the plume may be decreasing in size and concentration. Additional groundwater data are required to confirm that the plume is receding. Neither total BTEX or chlorinated solvents were detected in the groundwater samples collected from TF-1A, the upgradient well sampled in 1993 and 1994. O'Brien and Gere (1994) reported that previous studies have shown that VOC contamination has not migrated vertically from the shallow groundwater.

2.1.4.4 ELECTRICAL RESISTIVITY SURVEYS

In 1986 ES (1988) performed a series of soil electrical resistivity (ER) surveys at FT-03: however, the results of the FT-03 surveys were not available at the time this document was produced.

TABLE 2.9
 SUMMARY OF GROUND WATER ANALYTICAL DATA
 SITE FT-03
 INTRINSIC REMEDIATION TS
 WESTOVER ARB, MASSACHUSETTS

Location	Sample Date	Benzene (µg/l)	Toluene (µg/l)	Ethylbenzene (µg/l)	Total		TPH (mg/l)	TCE (µg/l)	1,2-DCE (µg/l)	Naphthalene (µg/l)	TDS (mg/l)
					Xylenes (µg/l)	BTEX (µg/l)					
TF-1A	1993	ND ^{a/}	ND	ND	ND	ND	0.8 JB ^{b/}	ND	ND	ND	55.0
	1994	ND	ND	ND	ND	ND	NA ^{c/}	ND	ND	ND	NA
TF-2	1994	ND	ND	ND	ND	ND	NA	ND	ND	ND	NA
	1993	6.9 J ^{d/}	540.0	450.0	1700.0	2690.0	20.0	ND	44.0	29.0	226.0
TF-2A	1994	3.6 J	27.0	240.0	370.0	640.6	NA	ND	26.0	ND	NA
	1994	ND	ND	ND	ND	ND	NA	ND	ND	ND	NA
TF-3	1993	ND	ND	22.0	7.6	29.6	0.35 JB	ND	4.0 J	ND	100.0
	1994	ND	ND	1.5 J	ND	1.5 J	NA	ND	2.0 J	ND	NA
TF-7	1993	ND	0.27 JB	ND	ND	0.27 JB	1.1 JB	ND	ND	ND	201.0
	1994	ND	ND	ND	ND	ND	NA	ND	ND	ND	NA
TF-8	1993	ND	0.39 JB	ND	1.4 JB	1.8 JB	0.52 JB	ND	4.1 J	ND	229.0
	1994	ND	ND	ND	ND	ND	NA	1.4 J	1.4 J	ND	NA
TF-11	1993	ND	0.28 JB	13.0	12.0	25.0	0.98 JB	ND	1.9 J	ND	160.0
	1994	1.4 J	0.94 J	69.0	2.7	71.7	NA	ND	15 J	4.6 J	NA

Source: O'Brien and Gere, 1994 and 1995.

^{a/} ND = Not detected.

^{b/} JB = Sample result is approximate and may reflect blank contamination.

^{c/} NA = Not analyzed.

^{d/} J = Result is detected below the reporting limit and is an estimated concentration.

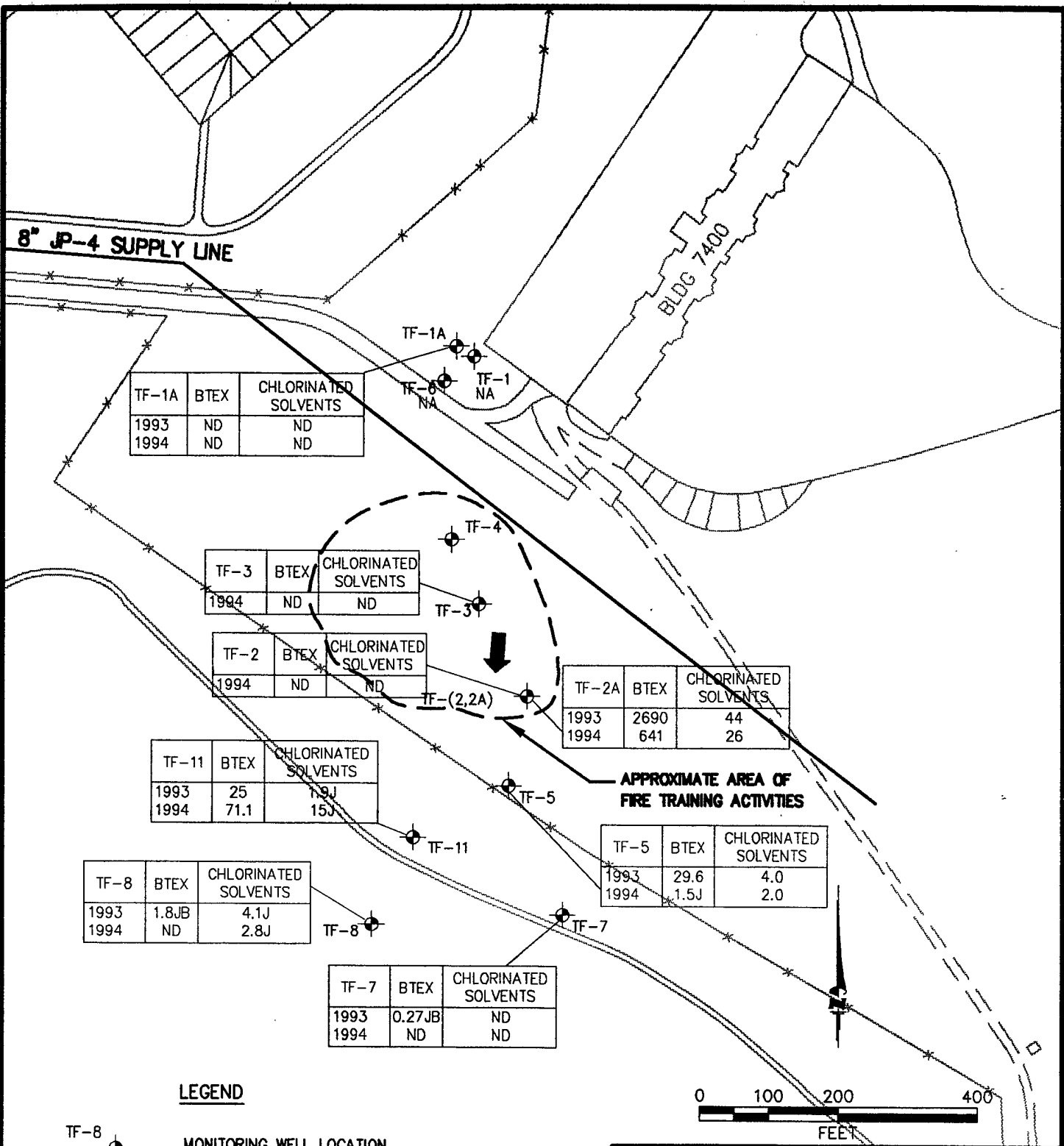

TF-1A	BTEX	CHLORINATED SOLVENTS
1993	ND	ND
1994	ND	ND

TF-3	BTEX	CHLORINATED SOLVENTS
1994	ND	ND

TF-2	BTEX	CHLORINATED SOLVENTS
1994	ND	ND

TF-2A	BTEX	CHLORINATED SOLVENTS
1993	2690	44
1994	641	26

TF-11	BTEX	CHLORINATED SOLVENTS
1993	25	1.9J
1994	71.1	15J

APPROXIMATE AREA OF FIRE TRAINING ACTIVITIES

TF-5	BTEX	CHLORINATED SOLVENTS
1993	29.6	4.0
1994	1.5J	2.0

TF-8	BTEX	CHLORINATED SOLVENTS
1993	1.8JB	4.1J
1994	ND	2.8J

TF-7	BTEX	CHLORINATED SOLVENTS
1993	0.27JB	ND
1994	ND	ND

LEGEND

- TF-8 MONITORING WELL LOCATION
- FENCE
- GROUNDWATER FLOW DIRECTION
- ND NOT DETECTED
- J ESTIMATED VALUE
- JB ESTIMATED VALUE, COULD BE LABORATORY CONTAMINANT
- NA NOT ANALYZED



FIGURE 2.16
GROUNDWATER BTEX AND CHLORINATED SOLVENT CONCENTRATIONS
SITE FT-03
 Intrinsic Remediation TS
 Westover ARB, Massachusetts

PARSONS ENGINEERING SCIENCE, INC.
 Denver, Colorado

2.2 DEVELOPMENT OF CONCEPTUAL MODELS

A conceptual model is a three-dimensional representation of a site hydrogeologic system based on available geological, hydrological, climatological, and geochemical data. A site conceptual model is developed to provide an understanding of the mechanisms controlling contaminant fate and transport and to identify additional data requirements. The model describes known and suspected sources of contamination, types of contamination, affected media, and contaminant migration pathways. The model also provides a foundation for formulating decisions regarding additional data collection activities and potential remedial actions. The conceptual models for FT-08 and FT-03 will be used to aid in selecting additional data collection points and to identify appropriate data needs for modeling chlorinated solvent and hydrocarbon degradation using groundwater flow and solute transport models.

Successful conceptual model development involves:

- Defining the problem to be solved;
- Integrating available data, including
 - Local geologic and topographic data,
 - Hydraulic data,
 - Site stratigraphic data,
 - Contaminant concentration and distribution data;
- Evaluating contaminant fate and transport characteristics;
- Identifying contaminant migration pathways;
- Identifying potential receptors; and
- Determining additional data requirements.

2.2.1 Intrinsic Remediation and Groundwater Flow and Solute Transport Models

After a site has been adequately characterized, fate and transport analyses can be performed to determine the potential for contaminant migration and whether any pathway for exposure of human or ecological receptors to site contaminants may be complete. Groundwater flow and solute transport models have proven useful for predicting BTEX plume migration and contaminant attenuation by natural biodegradation. Analytical solute transport models and the Bioplume II numerical model (Rifai *et al.*, 1988) can be used to evaluate critical groundwater fate and transport processes that may be involved in some of the migration pathways to human and ecological receptors. Quantitative fate and transport analyses can be used to determine what level and extent of remediation is required.

An accurate estimate of the potential for natural biodegradation of BTEX compounds in groundwater is important to consider when determining whether fuel hydrocarbon contamination presents a substantial threat to human health and the environment, and when deciding what type of remedial alternative will be most cost

effective in eliminating or abating these threats. Over the past two decades, numerous laboratory and field studies have demonstrated that subsurface microorganisms can degrade a variety of hydrocarbons (Lee, 1988). This process occurs naturally when sufficient oxygen (or other electron acceptors) and nutrients are available in the groundwater. The rate of natural biodegradation is generally limited by the lack of oxygen (or other electron acceptors) rather than by the lack of nutrients such as nitrogen or phosphorus. The supply of oxygen to unsaturated soil is constantly renewed by the vertical diffusion from the atmosphere. The supply of oxygen to a shallow, fuel-contaminated aquifer is constantly renewed by the influx of oxygenated, upgradient flow and the vertical diffusion of oxygen from the unsaturated soil zone into the groundwater (Borden and Bedient, 1986). The rate of natural biodegradation in unsaturated soil and shallow aquifers is largely dependent upon the rates at which oxygen and other electron acceptors enter the contaminated media.

2.2.2 Biodegradation of Dissolved BTEX Contamination

The positive effect of nature attenuation (e.g., advection, dispersion, sorption, and biodegradation) processes on reducing the actual mass of fuel-related contamination dissolved in groundwater has been termed intrinsic remediation. Advantages of intrinsic remediation include: (1) contaminants are transformed to innocuous byproducts (e.g., carbon dioxide and water), not just transferred to another phase or location within the environment; (2) current pump-and-treat technologies are energy intensive and generally not as effective in reducing residual contamination; (3) the process is nonintrusive and allows continuing use of infrastructure during remediation; (4) current engineered remedial technologies may pose a greater risk to potential receptors than intrinsic remediation because contaminants may be transferred into the atmosphere during remediation activities; and (5) intrinsic remediation is far less costly than conventional, engineered remedial technologies.

To estimate the impact of natural attenuation on the fate and transport of BTEX compounds dissolved in groundwater at a site, two important lines of evidence must be demonstrated (Wiedemeier *et al.*, 1995). The first is a documented loss of contaminants at the field scale. Dissolved concentrations of biologically-recalcitrant tracers found in most fuel contamination are used in conjunction with aquifer hydrogeologic parameters such as groundwater seepage velocity and dilution to demonstrate that a reduction in contaminant mass is occurring at the site. The second line of evidence involves the use of chemical analytical data in mass-balance calculations to show that areas with BTEX contamination can be correlated to areas with depleted electron acceptor (e.g., oxygen, nitrate, and sulfate) concentrations and increases in metabolic fuel degradation byproduct concentrations (e.g., methane and ferrous iron). With this site-specific information, groundwater flow and solute transport models can be used to simulate the fate and transport of dissolved BTEX compounds under the influence of the process of natural attenuation.

Analytical and numerical models are available for modeling the fate and transport of fuel hydrocarbons under the influence of advection, dispersion, sorption, and natural aerobic and anaerobic biodegradation. Analytical models derived from advection-dispersion equations and/or the Bioplume II numerical model will be used as

appropriate. The analytical solute transport models are derived from advection-dispersion equations given by Wexler (1992) and Van Genuchten and Alves (1982). These models provide exact, closed-form solutions and are appropriately used for relatively simple hydrogeologic systems that are homogeneous and isotropic. Each model is capable of simulating advection, dispersion, sorption, and biodegradation (or any first-order decay process). These models can simulate continuous or decaying sources. A continuous source model is useful for determination of the worst-case distribution of the dissolved contaminant plume. A decaying source model is useful for simulating scenarios including natural weathering processes source removal with an engineered solution.

The Bioplume II numerical model is based upon the US Geological Survey (USGS) two-dimensional (2-D) solute transport model, which has been modified to include a biodegradation component that is activated by a superimposed plume of dissolved oxygen. Bioplume II solves the USGS 2-D solute equation twice, once for hydrocarbon concentrations in the groundwater and once for a dissolved oxygen plume. The two plumes are then combined using superimposition at every particle move to simulate biological reactions between fuel products and oxygen. If appropriate, biodegradation of contaminants by anaerobic processes is simulated using a first-order anaerobic decay rate.

2.2.3 Initial Conceptual Models

2.2.3.1 Site FT-08

Site FT-08 geologic data were previously integrated to produce a geologic cross-section of the site. Cross-section A - A' (Figure 2.5) shows the dominant hydrostratigraphic units present at the site and the position of the water table. Figure 2.6 is a groundwater surface map prepared using 1987 groundwater elevation data (ES, 1988).

Groundwater is present approximately 5 feet bgs in the sand and gravel deposits in the vicinity of the site, and it flows to the southeast. The relatively low hydraulic gradient inhibits groundwater movement. The deeper till and bedrock aquifers do not receive any vertical recharge due to the thick sequence of varved clay and silt deposits below the sand and gravel aquifer. On the basis of the available data, Parsons ES will model the site as an unconfined, fine- to coarse-grained sand and gravel aquifer. This conceptual model will be modified as necessary as additional site hydrogeologic data become available.

Light nonaqueous-phase liquid (LNAPL) is not believed to be present at FT-08. However, if LNAPL is encountered, it may be necessary to use the fuel/water partitioning models of Bruce *et al.* (1991) or Cline *et al.* (1991) to provide a conservative source term to model the partitioning of BTEX from the free-product phase into the groundwater. In order to use one of these models, samples of free product will be collected and analyzed for mass fraction of BTEX. If LNAPL is present, Parsons ES will attempt to collect groundwater samples from immediately below the LNAPL layer, if possible.

The chemicals of concern in groundwater at FT-08, BTEX and chlorinated solvents, will be the primary focus of this intrinsic remediation study because of their regulatory importance. The Bioplume II model will be used to simulate the degradation of these chemicals at FT-08 and will be used to predict the concentrations and extent of the contaminant plume in the groundwater over time.

The chemicals of concern for the site are expected to leach from contaminated soil, which contains fuel and chlorinated solvent residuals, into the groundwater and to migrate downgradient as a dissolved contaminant plume. In addition to the effects of mass transport mechanisms (volatilization, dispersion, diffusion, and adsorption), these dissolved contaminants will likely be removed from the groundwater system by naturally occurring destructive attenuation mechanisms, such as biodegradation or cometabolism. The effects of these fate and transport processes on the dissolved groundwater plume will be investigated using the quantitative groundwater analytical data and the solute-transport models. Data collection and analysis requirements are discussed in Section 3 of this work plan.

2.2.3.2 Site FT-03

Previously collected data indicate Site FT-03 groundwater to be approximately 40 feet bgs and flowing to the south towards Chicopee Memorial State Park. Cross-section B-B' (Figure 2.8) shows the depth to groundwater relative to the subsurface hydrostratigraphic units. Figure 2.9 is a groundwater contour map of the site using water level data from July 1993. The shallow groundwater occurs in the fine sands above the varved lacustrine silt and clay deposits. Migration of contamination to the deep Triassic-age bedrock aquifer is not likely, due to the varved clay aquitard between the shallow and deep aquifers. On the basis of the available data, Parsons ES will model the site as an unconfined, fine silty sand to fine sand aquifer. This conceptual model will be modified as necessary as additional site hydrogeologic data become available.

LNAPL is not believed to be present at Site FT-03 site. However, if it is encountered, it may be necessary to use the fuel/water partitioning models of Bruce *et al.* (1991) or Cline *et al.* (1991) to provide a conservative source term to model the partitioning of BTEX compounds from the free-product phase into the groundwater. In order to use one of these models, samples of product will be collected and analyzed for mass fraction of BTEX compounds. If LNAPL is present, Parsons ES will attempt to collect groundwater samples from immediately below the LNAPL layer, if possible.

The chemicals of concern in groundwater at FT-03 include BTEX and chlorinated solvents, all of which will be the focus of this intrinsic remediation study because of their regulatory importance. Analytical groundwater flow and solute transport models will be used to simulate the migration and degradation of the chemicals of concern at FT-03 and will be used to predict the concentration and extent of the groundwater contaminant plume over time.

The chemicals of concern for the site are expected to leach from contaminated soil, which may contain fuel and chlorinated solvent residuals, into the groundwater and

migrate downgradient as a dissolved contaminant plume. In addition to the effects of mass transport mechanisms (volatilization, dispersion, diffusion, and adsorption), these dissolved contaminants will likely be removed from the groundwater system by naturally occurring destructive attenuation mechanisms, such as biodegradation or cometabolism. The effects of these fate and transport processes on the dissolved groundwater plume will be investigated using the quantitative groundwater analytical data and analytical groundwater flow and solute transport models. Data collection and analysis requirements are discussed in Section 3 of this work plan.

2.2.4 Potential Pathways and Receptors

Potential preferential contaminant migration pathways such as groundwater discharge points and subsurface utility corridors (artificial conduits) will be identified during the field work phase of this project. The primary potential migration path for contaminants at both sites is from the remaining contaminated soils at the site to the groundwater, and from the groundwater to potential receptors via consumption or incidental contact.

2.2.4.1 Site FT-08

Shallow groundwater beneath FT-08 flows toward the southeast. There are no known operating potable or nonpotable water wells (other than monitoring wells) located within considerable distance from the site. Surface drainage by overland flow from the site is to the north and northwest toward Stony Creek, which flows northward toward the Connecticut River. Because the site is secured by fencing and is isolated in a low-use area of the Base, flora and fauna are the probable receptors of any soil, surface water, or sediment contamination.

The potential for exposure to contaminated water originating from the site through ingestion is low because Base access is restricted and Base drinking water does not come from wells located near the Site FT-08. There are residential areas near the Base and several trailer parks, but their water is supplied from the city water system. Some local residents rely on water from wells in the shallow unconfined aquifer, but the closest such domestic wells are located several miles downgradient from the FT-08 site.

2.2.4.2 Site FT-03

Shallow groundwater at FT-03 flows south. There are no known operating potable or nonpotable water wells located downgradient within considerable distance of the site. Chicopee Reservoir is located approximately 0.4 mile downgradient from the site. Contaminated groundwater flow into the reservoir or the adjacent Cooley Brook is a potentially complete migration pathway. In 1994, BTEX compounds were detected in the downgradient monitoring well TF-8, located in Chicopee Memorial State Park. This well appears to represent the downgradient edge of the contaminant plume (O'Brien and Gere, 1995).

The potential for exposure to site contaminated drinking water supplies is low because at present, the contaminant plume has not reached Chicopee reservoir or

Cooley Brook. Also, Chicopee Reservoir is used for recreation, and is not a potable water supply. If contamination of the reservoir were to occur, there would be a low potential for exposure to dilute site contaminants. Overland flow and contamination from the site may also contaminate Cooley Brook and the Reservoir. Because the site is fenced, flora and fauna are the probable receptors of any soil, surface water, or sediment contamination on Base. Off-Base potential receptors include Chicopee Memorial State Park visitors, vegetation, and native state park animals and fish.

SECTION 3

COLLECTION OF ADDITIONAL DATA

To complete the TS and to demonstrate that intrinsic remediation of fuel-related contaminants and chlorinated solvents is occurring, additional site-specific hydrogeologic data will be collected. The physical and chemical hydrogeologic parameters listed below will be determined during the field work phase of the TS.

Physical hydrogeologic characteristics to be determined include:

- Depth from measurement datum to the groundwater surface in site monitoring wells;
- Locations of potential groundwater recharge and discharge areas;
- Locations of downgradient wells and their uses;
- Hydraulic conductivity through slug tests, as required;
- Estimate of dispersivity, where possible;
- Stratigraphic analysis of subsurface media;
- Groundwater temperature; and
- Determination of extent and thickness of free- and residual-phase product.

Chemical hydrogeologic characteristics to be determined include:

- Dissolved oxygen concentration;
- Specific conductance;
- pH;
- Chemical analysis of free product (if present) to determine mass fraction of BTEX;
and

- Additional chemical analysis of groundwater (and soil at FT-08) for the parameters listed in Table 3.1.

To obtain these data, soil, groundwater, and if present, free product samples will be collected and analyzed. The following sections describe the procedures that will be followed when collecting additional site-specific data. Samples from site FT-03 will be collected only from previously installed or newly installed groundwater monitoring wells. The Base will be responsible for new well installation. Soil sampling and well point installation at Site FT-08 will be accomplished using the Geoprobe® system, which is described in Sections 3.1 and 3.2. Procedures to be used to collect soil core samples are described in Section 3.1. Procedures to be used for the installation of new monitoring points are described in Section 3.2. Procedures to be used to sample groundwater monitoring wells and newly installed groundwater monitoring points are described in Section 3.3. Procedures used to measure aquifer parameters (e.g. hydraulic conductivity) are described in Section 3.4.

3.1 SOIL SAMPLING

The following sections describe sample locations, sample collection techniques, equipment decontamination procedures, site restoration, and management of investigation-derived waste materials.

3.1.1 Soil Sample Locations and Required Analyses

Soil samples will be collected at all Geoprobe® and monitoring point installation locations. Figure 3.1 identifies the proposed locations of soil sample collection at Site FT-08. Table 3.1 presents an analytical protocol for groundwater and soil samples, and Appendix A contains detailed information on the analyses and methods used during this sampling effort. Soil samples have not been scoped for the investigation at FT-03 because characterization of source area soils is being performed as a part of the installation of a soil bioventing remediation system. If, however, total organic carbon (TOC) has not been analyzed in FT-03 soil samples, up to two samples may be collected and analyzed for TOC from a location upgradient or well downgradient of the contaminant source.

A minimum of two samples will be collected from each hole location. One sample will be taken at the water table and one will be taken at the depth of maximum BTEX contamination as determined by soil headspace screening. Sampling locations include suspected source areas in the vicinity of the waste fuel tank, the buried fuel line, and the burn area. Samples will also be collected at location forming a series of arcs radiating outward from the source areas in the direction of groundwater flow. Additional samples and sampling intervals will be collected at the discretion of the Parsons ES scientist.

A portion of each sample will be used to measure soil headspace while another portion of selected samples will be sent to the laboratory for analytical analysis. Each

TABLE 3.1
ANALYTICAL PROTOCOL FOR
GROUNDWATER AND SOIL SAMPLES
SITES FT-03 AND FT-08
INTRINSIC REMEDIATION TS
WESTOVER ARB, MASSACHUSETTS

MATRIX Analyte	METHOD	FIELD (F) OR ANALYTICAL LABORATORY (L)
WATER		
Total Iron	Colorimetric, HACH Method 8008	F
Ferrous Iron (Fe ²⁺)	Colorimetric, HACH Method 8146	F
Ferric Iron (Fe ³⁺)	Difference between total and ferrous iron	F
Manganese	Colorimetric, HACH Method 8034	F
Sulfate	Colorimetric, HACH Method 8051	F
Nitrate	Titrimetric, HACH Method 8039	F
Nitrite	Titrimetric, HACH Method 8507	F
Redox Potential	A2580B, direct reading meter	F
Oxygen	Direct reading meter	F
pH	E150.1/SW9040, direct reading meter	F
Conductivity	E120.1/SW9050, direct reading meter	F
Temperature	E170.1	F
Carbon Dioxide	Titrimetric, HACH Method 1436-01	F
Alkalinity (Carbonate [CO ₃ ²⁻] and Bicarbonate [HCO ₃ ⁻])	F = Titrimetric, HACH Method 8221 L = EPA method 310.1	L
Nitrate + Nitrite	EPA Method 353.1	L
Chloride	Waters Capillary Electrophoresis Method N-601	L
Sulfate	Waters Capillary Electrophoresis Method N-601	L
Methane, Ethane, Ethene	RSKSOP-147	L
Dissolved Organic Carbon	RSKSOP-102	L
VOCs	RSKSOP-148	L
Fuel Carbon	RSKSOP-148	L
SOIL		
Total Organic Carbon	RSKSOP-102 & RSKSOP-120	L
Moisture	ASTM D-2216	L
Aromatic Hydrocarbons	RSKSOP-124, modified	L
VOCs	RSKSOP-148	L
Total Hydrocarbons	RSKSOP-174	L
FREE PRODUCT		
BTEX Mass Fraction	GC/MS, Direct Injection	L

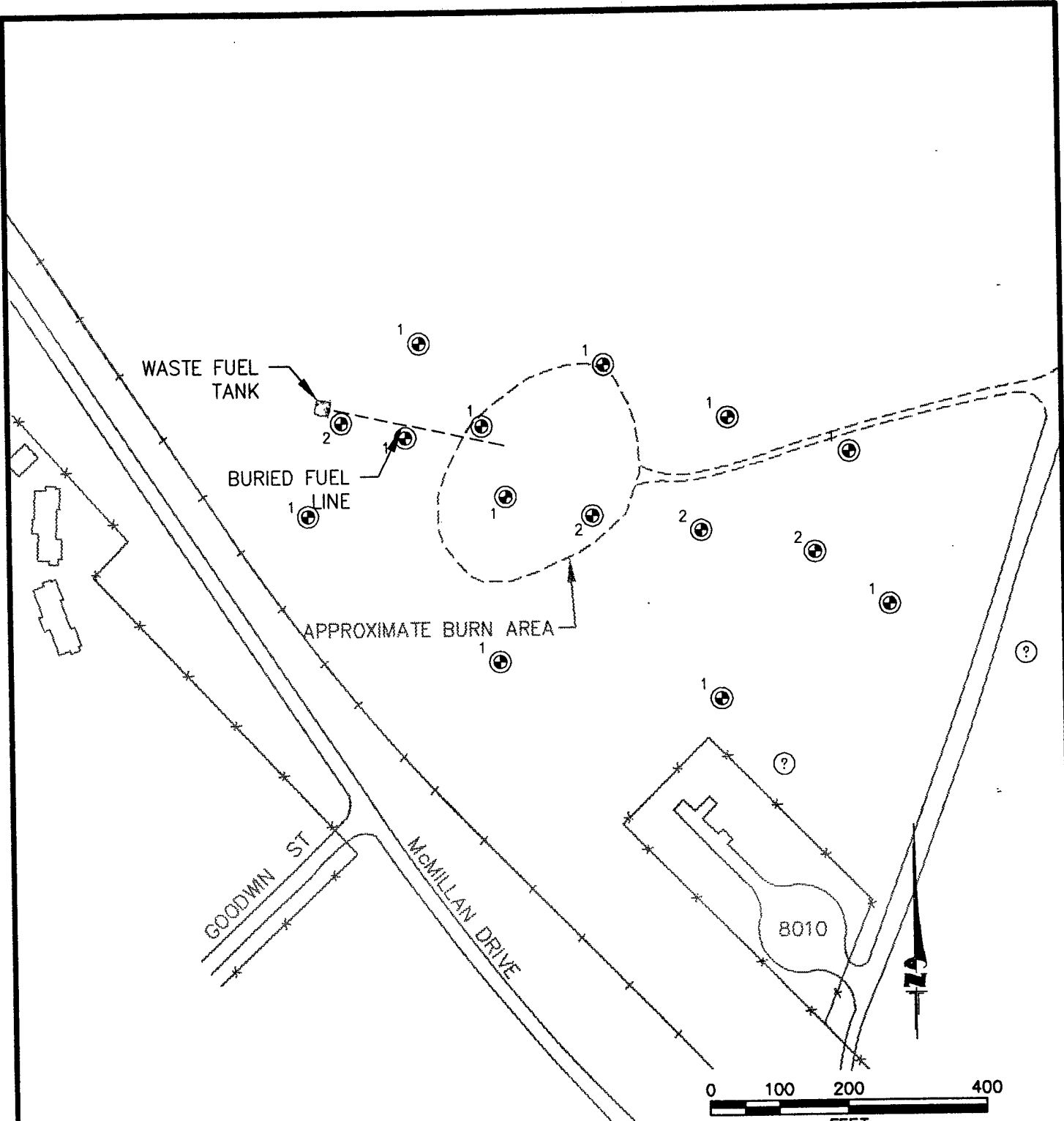

LEGEND

- ⊕ CURRENT MONITORING WELL LOCATION
- ⊙² PROPOSED SAMPLING AND/OR MONITORING POINT LOCATION WITH NUMBER OF MONITORING POINTS
- ⊙[?] POSSIBLE PROPOSED SAMPLING LOCATION; DEPENDENT ON INITIAL INVESTIGATION RESULTS

FIGURE 3.1

PROPOSED GEOPROBE SAMPLING AND/OR MONITORING POINT INSTALLATION SITE FT-08

Intrinsic Remediation TS
Westover ARB, Massachusetts

PARSONS ENGINEERING SCIENCE, INC.
Denver, Colorado

laboratory soil sample will be placed in an analyte-appropriate sample container and hand-delivered to the USEPA field personnel for analysis of total hydrocarbons, aromatic hydrocarbons, and moisture content using the procedures presented in Table 3.1. In addition, at least two samples will be analyzed for TOC from locations upgradient, crossgradient, or far downgradient of the contaminant source. Each headspace screening sample will be placed in a sealed plastic bag or mason jar and allowed to sit for at least 5 minutes. Soil headspace will then be determined using an organic vapor meter (OVM) and the results will be recorded in the field records by the Parsons ES field scientist.

3.1.2 Sample Collection Using the Geoprobe® System

Soil samples will be collected using a Geoprobe® system, a hydraulically powered percussion/probing machine capable of advancing sampling tools through unconsolidated soils. This system provides for the rapid collection of soil, soil gas, and groundwater samples at shallow depths while minimizing the generation of investigation-derived waste materials. Figure 3.2 is a diagram of the Geoprobe® system.

Soil samples will be collected using a probe-drive sampler. The probe-drive sampler serves as both the driving point and the sample collection device and is attached to the leading end of the probe rods. To collect a soil sample, the sampler is pushed or driven to the desired sampling depth, the drive point is retracted, to open the sampling barrel, and the sampler is subsequently pushed into the undisturbed soils. The soil cores are retained within brass, stainless steel, or clear acetate liners inside the sampling barrel. The probe rods are then retracted, bringing the sampling device to the surface. The soil sample can then be extruded from the liners for lithologic logging, or the liners can be capped and undisturbed samples submitted to the analytical laboratory for testing.

If the probe-drive sampling techniques described above are inappropriate, inadequate, or unable to efficiently provide sufficient soil samples for the characterization of the site, continuous soil samples will be obtained from conventional core boreholes using a hand auger or similar method judged acceptable by the Parsons ES field scientist. Procedures will be modified, if necessary, to ensure good sample recovery.

The Parsons ES field scientist will be responsible for observing all field investigation activities, maintaining a detailed descriptive log of all subsurface materials recovered during soil coring, photographing representative samples, and properly labeling and storing samples. An example of the proposed geologic boring log form is presented in Figure 3.3. The descriptive log will contain:

- Sample interval (top and bottom depth);
- Sample recovery;
- Presence or absence of contamination;

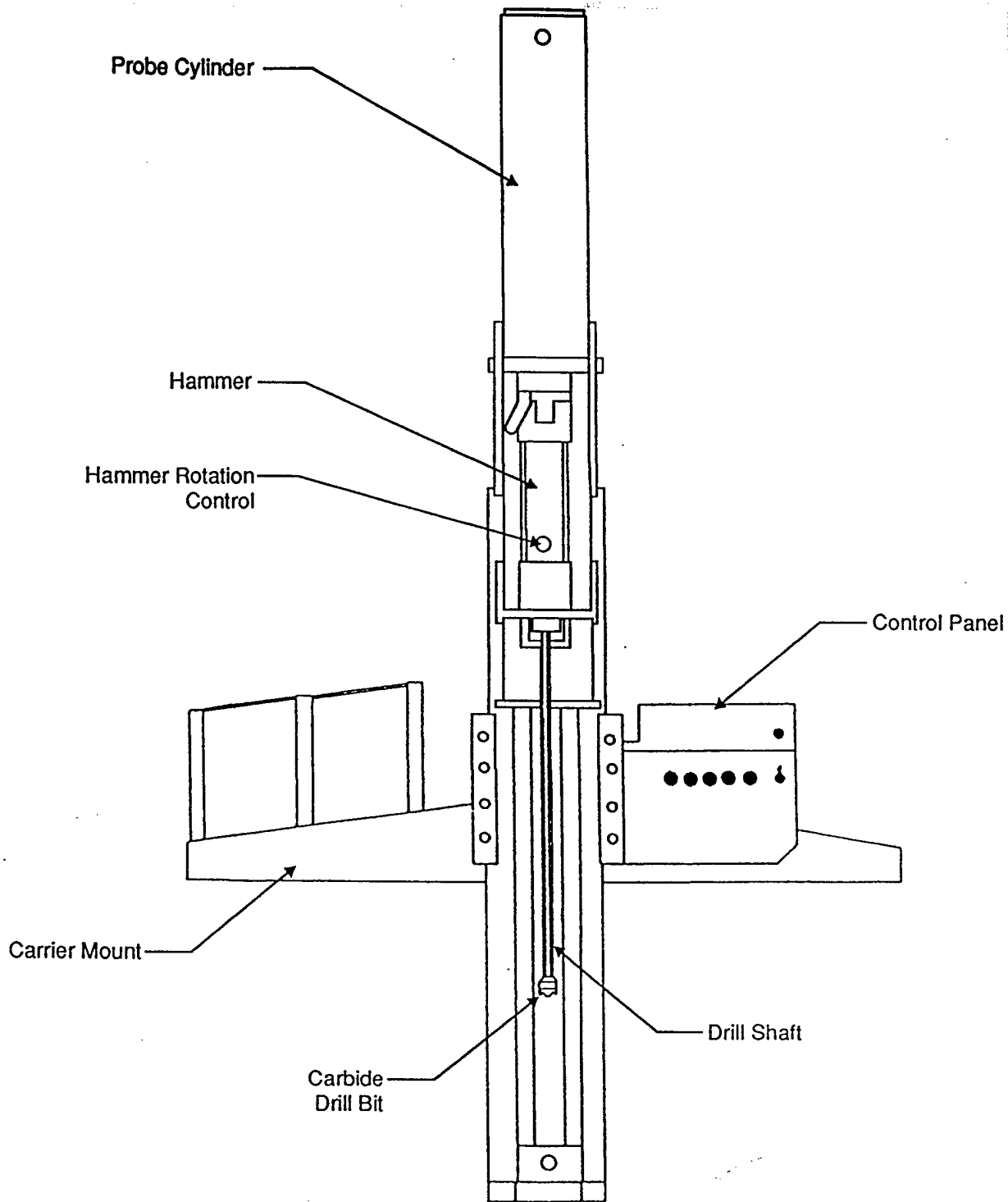

FIGURE 3.2

**CROSS SECTION
OF GEOPROBE**

Intrinsic Remediation TS
Westover ARB, Massachusetts



**PARSONS
ENGINEERING SCIENCE, INC.**

Denver, Colorado

GEOLOGIC BORING LOG

Sheet 1 of 1

BORING NO.: _____ CONTRACTOR: _____ DATE SPUD: _____
 CLIENT: AFCEE RIG TYPE: _____ DATE CMPL.: _____
 JOB NO.: 722450.28 DRLG METHOD: _____ ELEVATION: _____
 LOCATION: WESTOVER ARB BORING DIA.: _____ TEMP: _____
 GEOLOGIST: _____ DRLG FLUID: _____ WEATHER: _____
 COMMENTS: _____

Elev (ft)	Depth (ft)	Pro- file	US CS	Geologic Description	Sample		Penet Res	PID(ppm)	WKSPC PID(ppm)	TOTAL BTEX(ppm)	TPH (ppm)
					No.	Depth (ft)					
	1										
	5										
	10										
	15										
	20										
	25										
	30										
	35										

NOTES

bgs - Below Ground Surface
 GS - Ground Surface
 TOC - Top of Casing
 NS - Not Sampled
 SAA - Same As Above

SAMPLE TYPE

D - DRIVE
 C - CORE
 G - GRAB

Water level drilled

FIGURE 3.3

GEOLOGIC BORING LOG

Intrinsic Remediation TS
 Westover ARB, Massachusetts

**PARSONS
ENGINEERING SCIENCE, INC.**
 Denver, Colorado

- Lithologic description, including relative density, color, major textural constituents, minor constituents, porosity, relative moisture content, plasticity of fines, cohesiveness, grain size, structure or stratification, relative permeability, and any other significant observations; and
- Depths of lithologic contacts and/or significant textural changes measured and recorded to the nearest 0.1 foot.

Base personnel will be responsible for identifying the location of all utility lines, USTs, fuel lines, or any other underground infrastructure prior to any sampling activities. All necessary digging permits will be obtained by Base personnel prior to mobilizing to the field. Base personnel will also be responsible for acquiring drilling and monitoring point installation permits for the proposed locations. Parsons ES will be responsible for providing trained operators for the Geoprobe®.

3.1.3 Datum Survey

The horizontal location of all soil sampling locations relative to established Base coordinates will be measured by a surveyor. Horizontal coordinates will be measured to the nearest 0.1 foot. The elevation of the ground surface will also be measured to the nearest 0.1 foot relative to USGS msl data.

3.1.4 Site Restoration

After sampling is complete, each sampling location will be restored as closely to its original condition as possible. Holes created by the Geoprobe® in sandy soils similar to those found at the Base tend to cave in soon after extraction of the drive sampler. However, any test holes remaining open after extraction of the penetrometer rod will be sealed with bentonite chips, pellets, or grout to eliminate any creation or enhancement of contaminant migration pathways to the groundwater. Soil sampling using the Geoprobe® creates low volumes of soil waste. Soil not used for sampling will be placed in 55-gallon drums provided by the Base and disposed of by Base personnel. Alternate methods of soil waste disposal will be considered by the Parsons ES field scientist as recommended by Base personnel.

3.1.5 Equipment Decontamination Procedures

Prior to arriving at the site, and between each sampling location, probe rods, tips, sleeves, pushrods, samplers, tools, and other downhole equipment will be decontaminated using a high-pressure, steam/hot water wash. Only potable water will be used for decontamination. All rinseate will be collected in 55-gallon drums provided by the Base and later transported and disposed of by Base personnel.

Between each soil sample, the sampling barrel will be disassembled and decontaminated with Alconox® and potable water. The barrel will then be rinsed with deionized water and reassembled with new liners. Between uses, the sampling barrel will be wrapped in clean plastic or foil to prevent contamination.

Rinseate will be collected in 55-gallon drums provided by the Base. Filled 55-gallon drums will be stored at the Base, and Base personnel will arrange for final disposal of the drums and their contents. Base personnel are responsible for sampling the contents of the drums to identify any hazardous constituents before the drums are transported to an appropriate disposal facility.

Potable water to be used during equipment cleaning, decontamination, or grouting will be obtained from one of the Base water supplies. Water use approval will be verified by contacting the appropriate facility personnel. The field scientist will make the final determination as to the suitability of site water for these activities. Precautions will be taken to minimize any impact to the surrounding area that might result from decontamination operations.

3.2 MONITORING POINT INSTALLATION

To further characterize site hydrogeologic conditions, up to 21 groundwater monitoring points may be installed at FT-08 to supplement the site monitoring wells. The installation of monitoring points is not scoped for FT-03 because the groundwater BTEX plume has already been defined by the 11 site wells; furthermore, additional groundwater monitoring wells may be installed prior to mobilization for this investigation. The following sections describe the proposed monitoring point locations and completion intervals, monitoring point installation, monitoring point development, and equipment decontamination procedures.

3.2.1 Monitoring Point Locations and Completion Intervals

The locations of 21 proposed groundwater monitoring points are for FT-08 identified on Figure 3.1. The proposed locations for the new monitoring points were determined from a review of existing data gathered during previous site activities. Monitoring point locations were selected to provide hydrogeologic data necessary for successful implementation of the Bioplume II model and to monitor potential fuel hydrocarbon and chlorinated solvent migration from the site. Monitoring point locations were selected to define four aspects of the site: 1) the magnitude of the dissolved BTEX and solvent concentrations within suspected source areas, 2) the extent of contamination, 3) the horizontal and vertical distribution of dissolved BTEX and solvents, and 4) the hydrogeology and groundwater flow direction at the site. The proposed locations shown on Figure 3.1 may be modified in the field as a result of encountered field conditions and acquired field data.

Approximately eight monitoring points will be installed in suspected source areas: the burn area, the vicinity of the waste fuel tank, and along the buried fuel line. Five of the monitoring points are proposed for installation in clusters. Two monitoring points are proposed to be installed in a cluster with monitoring wells CF-2 and 2A. Another monitoring point is proposed to be installed in a cluster between the screened intervals of monitoring well CF-3. The other two monitoring points are proposed for installation as a cluster near the waste fuel tank. These clusters have the dual purpose of evaluating source area concentrations as well as the vertical extent of contamination

within the source areas. Single source area monitoring points are proposed for three additional locations within suspected source areas. One monitoring point is proposed for the center of the burn area to evaluate groundwater at the hypothetical worst location. A second monitoring point is proposed for the northeastern edge of the main burn pit to evaluate the extent of the burn pit contamination. Monitoring well CF-5 serves a similar purpose on the south southwestern edge of the burn area. The third single monitoring point is proposed for installation along the buried fuel line halfway between the burn area and the waste fuel tank.

Eleven additional monitoring points have been proposed to evaluate the horizontal extent of the dissolved BTEX plume. Single points are proposed to the northeast and southwest of the waste fuel tank to define plume width at this location. The remaining nine points have been arranged to complete three arcs downgradient and sidegradient of the main burn area. Because the groundwater flow direction is not well defined, the direction of plume migration is also not well defined; therefore, the installation of these points was judged important to evaluate groundwater flow gradients and the plume extent. Two of the monitoring points located immediately downgradient of the burn pit are proposed for installation as a cluster to evaluate the vertical extent of contamination. Two optional monitoring points have been reserved to further define the extent of contamination. If needed these points will be used to extend an arc or to add an additional downgradient arc.

Each monitoring point will have a screened interval of 1 meter. Single monitoring points will be screened near the top of the saturated zone. Monitoring point clusters will be screened at the top of the saturated zone and above the fine silty sand. The exact depth of monitoring points will be determined by the Parsons ES field scientist on the basis of site conditions. The proposed screened intervals of 1 meter for shallow and deep monitoring points will help mitigate the dilution of water samples from potential vertical mixing of contaminated and uncontaminated groundwater in the monitoring point casing. Adjustments of the depth and length of the screened interval of the monitoring points may be necessary in response to actual aquifer conditions and contaminant distribution identified during Geoprobe[®] testing.

3.2.2 Monitoring Point Installation Procedures

3.2.2.1 Pre-Placement Activities

All necessary digging, coring, and drilling permits will be obtained prior to mobilizing to the field. In addition, all utility lines will be located, and proposed drilling locations will be cleared prior to any intrusive activities. Responsibilities for these permits and clearances are discussed in Section 3.1.1.

Water to be used in monitoring point installation and equipment cleaning will be obtained from one of the Base water supplies. Water use approval will be verified by contacting the appropriate facility personnel. The field scientist will make the final determination as to the suitability of site water for these activities.

3.2.2.2 Monitoring Point Materials Decontamination

Monitoring point installation and completion materials will be inspected by the field scientist and determined to be clean and acceptable prior to use. If not factory sealed, the well points and tubing will be cleaned prior to use with a high-pressure, steam/hot-water cleaner using approved water. Materials that cannot be cleaned to the satisfaction of the field scientist will not be used.

3.2.2.3 Installation and Materials

This section describes the procedures to be used for installation of monitoring points. Monitoring points will be installed using either 0.375-inch Teflon[®] tubing connected to a 0.5-inch diameter stainless steel screen or a 0.5 inch inside-diameter (ID)/0.75 inch outside-diameter (OD) polyvinyl chloride (PVC) screen and casing.

3.2.2.3.1 Deep Monitoring Points

The deep monitoring points will be installed in boreholes punched using the Geoprobe[®]. The deep monitoring points will be constructed of a sacrificial drive point attached to a length of 0.5-inch diameter stainless steel mesh that functions as the well screen, which in turn is connected to 0.375-inch Teflon[®] tubing.

To install the deep monitoring points, the borehole is punched and sampled to several feet above the target depth for the monitoring point. The probe rods are withdrawn from the borehole, and the soil sampler is replaced with the well point assembly. An appropriate length of Teflon[®] tubing is threaded through the probe rods and attached to the well point. The assembly is lowered into the borehole and then driven down to the target depth and sampling zone. The probe rods are removed, leaving the sacrificial tip, screen assembly, and tubing behind. The soil is likely to cave in around the screen and tube assembly; where this does not occur, silica sand will be emplaced to create a sand pack around the well point, and the borehole annular space around the tubing above the sand pack will be filled with granular bentonite or grout to seal it. Monitoring point construction details will be noted on a Monitoring Point Installation Record form (Figure 3.4).

3.2.2.3.2 Shallow Monitoring Points

If subsurface conditions permit, shallow monitoring points will be constructed of 0.75-inch OD/0.5-inch ID PVC casing and well screen to provide additional water level information. Approximately 1 meter of factory-slotted screen will be installed for each shallow monitoring point. Effective installation of the shallow monitoring points requires that the boreholes remain open upon completion of drilling. Shallow 0.5-inch ID PVC monitoring points will be installed by punching and sampling a borehole with the Geoprobe[®]. Upon removing the rods, the borehole depth will be measured to determine if the hole is staying open. If the borehole remains open, the 0.5-inch ID PVC casing and screen will be placed at the appropriate depths. The annular space around the screen will be filled with sand filter pack, and the annulus around the casing

MONITORING POINT INSTALLATION RECORD

JOB NAME WESTOVER AIR FORCE RESERVE BASE MONITORING POINT NUMBER _____
 JOB NUMBER 722450.28 INSTALLATION DATE _____ LOCATION _____
 DATUM ELEVATION _____ GROUND SURFACE ELEVATION _____
 DATUM FOR WATER LEVEL MEASUREMENT _____
 SCREEN DIAMETER & MATERIAL _____ SLOT SIZE _____
 RISER DIAMETER & MATERIAL _____ BOREHOLE DIAMETER _____
 CONE PENETROMETER CONTRACTOR _____ ES REPRESENTATIVE _____

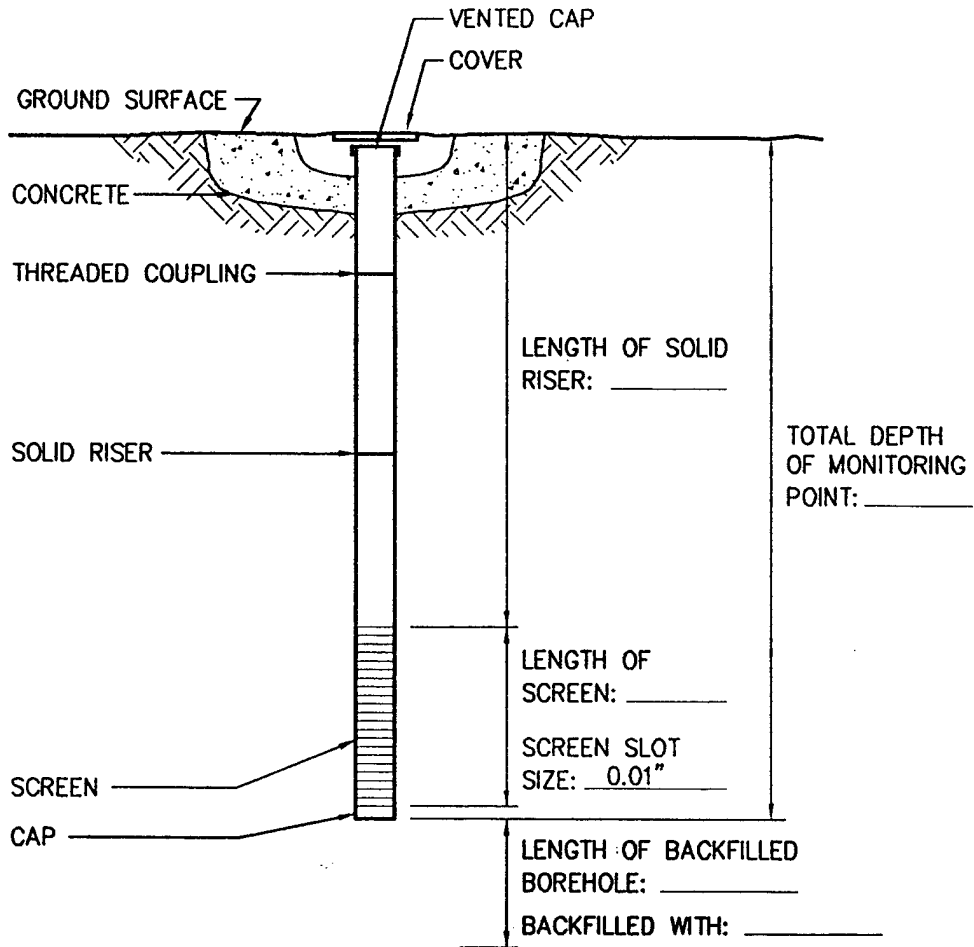

(NOT TO SCALE)

STABILIZED WATER LEVEL _____ FEET
 BELOW DATUM.
 TOTAL MONITORING POINT DEPTH _____ FEET
 BELOW DATUM.
 GROUND SURFACE _____ FEET

FIGURE 3.4

MONITORING POINT INSTALLATION RECORD

Intrinsic Remediation TS
 Westover ARB, Massachusetts



**PARSONS
ENGINEERING SCIENCE, INC.**

Denver, Colorado

will be filled with grout or bentonite. Monitoring point construction details will be noted on a Monitoring Point Installation Record form (Figure 3.4). This information will become part of the permanent field record for the site.

Temporary monitoring point screens will be constructed of flush-threaded, Schedule 40 PVC with an ID of 0.5 inch. The screens will be factory slotted with 0.01-inch openings. Monitoring point screens will be placed to sample and provide water level information at or near the water table. Blank monitoring point casing will be constructed of Schedule 40 PVC with an ID of 0.5 inch. All monitoring point casing sections will be flush-threaded; joints will not be glued. The casing at each monitoring point will be fitted with a bottom cap and a top cap constructed of PVC.

If subsurface conditions do not permit the boreholes to stay open (i.e. the formation collapses in the hole), shallow 0.5-inch-ID PVC monitoring points may be installed using the Geoprobe[®]. If the installation of 0.5-inch PVC monitoring points is not possible or is impractical using the Geoprobe[®], monitoring points constructed of 0.375-inch Teflon[®] described in Section 3.2.2.3.1 will be installed. Should 0.5-inch ID PVC shallow monitoring points not be installed, the only resulting data gap will be the lack of water level information for that particular location. The decision to install 0.5-inch-ID PVC monitoring points will be made in the field once the open-hole stability of subsurface soils and Geoprobe[®] equipment can be evaluated.

The field scientist will verify and record the total depth of the monitoring point, the lengths of all casing sections, and the depth to the top of all monitoring point completion materials. All lengths and depths will be measured to the nearest 0.1 foot.

3.2.2.4 Monitoring Point Completion or Abandonment

A number of the monitoring points will be completed above grade, and steel protective casing will be used to protect the well points from tampering and damage. Where pavement is present, an at-grade cover will be cemented in place using concrete blended into the existing pavement. Where pavement is not present, the protective cover will be raised slightly above the ground surface with a 1-foot square concrete pad that will slope gently away from the cover to facilitate runoff during precipitation events. The number of permanent monitoring points will be determined by the Parsons ES field scientist. The completion of the monitoring points will be similar to those protecting the existing monitoring wells unless otherwise specified by Base personnel.

Those monitoring points not completed with an external protective casing will be abandoned. The PVC casing and screen or Teflon[®] tubing will be extracted as far as possible and discarded. While holes created by the Geoprobe[®] in sandy soils similar to those found at the Base tend to cave in soon after extraction of the drive rod, any test holes remaining open after extraction of the casing will be sealed with bentonite chips, pellets, or grout to eliminate any creation or enhancement of contaminant migration pathways to the groundwater.

After monitoring point completion or abandonment, each site will be restored as closely as possible to its original condition.

3.2.3 Monitoring Point Development and Records

The monitoring points will be developed prior to sampling to remove fine sediments from the portion of the formation adjacent to the well point screen. Development will be accomplished using a peristaltic pump provided by USEPA RSKERL or Parsons ES. The pump will be attached to the well point and water will be removed until pH, temperature, specific conductivity, and water clarity (turbidity) stabilize. Monitoring point development will occur a minimum of 24 hours prior to sampling.

A development record will be maintained for each monitoring point. The development record will be completed in the field by the field scientist. Figure 3.5 is an example of a development record used for similar well installations. Development records will include:

- Monitoring point number;
- Date and time of development;
- Development method;
- Monitoring point depth;
- Volume of water produced;
- Description of water produced;
- Post-development water level and monitoring point depth; and
- Field analytical measurements, including pH and specific conductivity.

Clean and contaminated development waters will be collected in 55-gallon drums provided by the Base. Developed groundwater which does not exhibit an odor, sheen, or other immediate evidence of contamination will be released to the ground at the point of origin. If the developed groundwater exhibits signs of contamination, it will be transported by Base personnel to the designated waste collection areas at the Base.

3.2.4 Monitoring Point Location and Datum Survey

The location and elevation of the well points will be surveyed soon after completion. Horizontal coordinates will be measured to the nearest 0.1 foot relative to established Base coordinates. The elevation of the ground surface adjacent to the protective casing will be measured relative to the USGS msl datum. The ground surface elevation will be measured to the nearest 0.1 foot. A top of casing datum will be measured to the nearest 0.01 foot for all monitoring points constructed of 0.5-inch PVC casing and well screen. Because water levels cannot be measured through the well point tubing, no datum elevation, such as top of casing, will be measured for monitoring points constructed with Teflon tubing.

MONITORING POINT DEVELOPMENT RECORD

Page ___ of ___

Job Number: 722450.28
Location: _____
Well Number: _____

Job Name: Westover ARB, Massachusetts
By: _____ Date: _____
Measurement Datum: _____

Pre-Development Information

Time (Start): _____

Water Level: _____

Total Depth of Well: _____

Water Characteristics

Color: _____ Clear Cloudy
Odor: None Weak Moderate Strong
Any Films or Immiscible Material: _____
pH: _____ Temperature (°F °C): _____
Specific Conductance (µS/cm): _____

Interim Water Characteristics

Gallons Removed _____

pH _____

Temperature (°F °C) _____

Specific Conductance (µS/cm) _____

Post-Development Information

Time (Finish): _____

Water Level: _____

Total Depth of Well: _____

Approximate Volume Removed: _____

Water Characteristics

Color: _____ Clear Cloudy
Odor: None Weak Moderate Strong
Any Films or Immiscible Material: _____
pH: _____ Temperature (°F °C): _____
Specific Conductance (µS/cm): _____

Comments: _____

FIGURE 3.5

MONITORING POINT DEVELOPMENT RECORD

Intrinsic Remediation TS
Westover ARB, Massachusetts



**PARSONS
ENGINEERING SCIENCE, INC.**

Denver, Colorado

3.2.5 Water Level Measurements

Water levels at existing monitoring wells and monitoring points will be measured within a short time period so that the water level data are comparable. The depth to water below the measurement datum will be measured to the nearest 0.01 foot using an electric water level probe or an oil-water interface probe.

3.3 GROUNDWATER SAMPLING PROCEDURES

This section describes the scope of work required for collection of groundwater quality samples. Samples will be collected from site monitoring wells (e.g., wells CF-1 through CF-8 at FT-08 and wells TF-1 through TF-8, TF-11, and any new wells at FT-03) and newly-installed groundwater monitoring points. A peristaltic pump with dedicated high-density polyethylene (HDPE) tubing will be used to collect groundwater samples at wells and monitoring points with a depth to groundwater of 25 feet or less. A Waterra inertial pump and/or a dedicated Teflon[®] bailer will be used to collect groundwater samples at locations where the depth to groundwater exceeds 25 feet. A Grundfos Redi-Flow II[®] may be used for well purging prior to sampling. In order to maintain a high degree of QC during this sampling event, the procedures described in the following sections will be followed.

Sampling will be conducted by qualified scientists and technicians from Parson ES and the USEPA RSKERL who are trained in the conduct of groundwater sampling, records documentation, and chain-of-custody procedures. In addition, sampling personnel will have thoroughly reviewed this work plan prior to sample acquisition and will have a copy of the work plan available onsite for reference. Groundwater sampling includes the following activities:

- Assembly and preparation of equipment and supplies;
- Inspection of the monitoring well/point integrity including:
 - Protective cover, cap, and lock,
 - External surface seal and pad,
 - Monitoring point stick-up, cap, and datum reference, and
 - Internal surface seal;
- Groundwater sampling, including:
 - Water level and product thickness measurements,
 - Visual inspection of sample water,
 - Monitoring point casing evacuation, and
 - Sample collection;
- Sample preservation and shipment, including:
 - Sample preparation,

- Onsite measurement of physical parameters, and
- Sample labeling;
- Completion of sampling records: and
- Sample disposition.

Detailed groundwater sampling and sample handling procedures are presented in following sections.

3.3.1 Preparation for Sampling

All equipment to be used for sampling will be assembled and properly cleaned and calibrated (if required) prior to arriving in the field. In addition, all record-keeping materials will be gathered prior to leaving the office.

3.3.1.1 Equipment Cleaning

All portions of sampling and test equipment that will contact the sample matrix will be thoroughly cleaned before each use. This includes the Geoprobe[®] soil sampling tool, sampling pumps, non-disposable bailers, water level probe and cable, test equipment for onsite use, and other equipment or portions thereof that will contact the samples. Given the types of sample analyses to be conducted, the following cleaning protocol will be used:

- Wash with potable water and phosphate-free laboratory detergent (HP-II detergent solutions, as appropriate);
- Rinse with potable water;
- Rinse with isopropyl alcohol;
- Rinse with distilled or deionized water; and
- Air dry.

Any deviations from these procedures will be documented in the field scientist's field notebook and on the groundwater sampling record (Figure 3.6).

If precleaned disposable sampling equipment is used, the cleaning protocol specified above will not be required. Laboratory-supplied sample containers will be cleaned and sealed by the laboratory. The type of container provided and the method of container decontamination will be documented in the USEPA mobile laboratory's permanent record of the sampling event.

3.3.1.2 Equipment Calibration

As required, field analytical equipment will be calibrated according to the manufacturers' specifications prior to field use. This applies to equipment used for onsite measurements of dissolved oxygen (DO), pH, electrical conductivity,

GROUNDWATER SAMPLING RECORD

SAMPLING LOCATION _____
SAMPLING DATE(S) _____
MONITORING WELL _____
(number)

REASON FOR SAMPLING: Regular Sampling; Special Sampling;
DATE AND TIME OF SAMPLING: _____, 19____ a.m./p.m.
SAMPLE COLLECTED BY: _____ of _____
WEATHER: _____
DATUM FOR WATER DEPTH MEASUREMENT (Describe): _____

MONITORING WELL CONDITION:
 LOCKED: UNLOCKED
WELL NUMBER (IS - IS NOT) APPARENT _____
STEEL CASING CONDITION IS: _____
INNER PVC CASING CONDITION IS: _____
WATER DEPTH MEASUREMENT DATUM (IS - IS NOT) APPARENT _____
 DEFICIENCIES CORRECTED BY SAMPLE COLLECTOR
 MONITORING WELL REQUIRED REPAIR (describe): _____

Check-off
1 EQUIPMENT CLEANED BEFORE USE WITH _____
Items Cleaned (List): _____

2 PRODUCT DEPTH _____ FT. BELOW DATUM
Measured with: _____
WATER DEPTH _____ FT. BELOW DATUM
Measured with: _____

3 WATER-CONDITION BEFORE WELL EVACUATION (Describe):
Appearance: _____
Odor: _____
Other Comments: _____

4 WELL EVACUATION:
Method: _____
Volume Removed: _____
Observations: Water (slightly - very) cloudy
Water level (rose - fell - no change)
Water odors: _____
Other comments: _____

FIGURE 3.6

GROUNDWATER SAMPLING RECORD

Intrinsic Remediation TS
Westover ARB, Massachusetts



PARSONS ENGINEERING SCIENCE, INC.
Denver, Colorado

temperature, redox potential, sulfate, nitrate, ferrous iron (Fe^{2+}), and other field parameters listed on Table 3.1.

3.3.2 Sampling Procedures

Special care will be taken to prevent contamination of the groundwater and extracted samples. The two primary ways in which sample contamination can occur are through contact with improperly cleaned equipment and through cross-contamination due to insufficient cleaning of equipment between wells and monitoring points. To prevent such contamination, the water level probe and cable used to determine static water levels and total well depths will be thoroughly cleaned before and after field use and between uses at different sampling locations according to the procedures presented in Section 3.3.1.1. Dedicated tubing will be used at each well or monitoring point developed, purged, and/or sampled with the peristaltic pump. Pumps and nondisposable bailers will be decontaminated according to procedures listed in Section 3.3.1.1. In addition to the use of properly cleaned equipment, a clean pair of new, disposable nitrile or latex gloves will be worn each time a different well or monitoring point is sampled. The following paragraphs present the procedures to be followed for groundwater sample collection from groundwater monitoring wells and monitoring points. These activities will be performed in the order presented below. Exceptions to this procedure will be noted in the field scientist's field notebook or on the groundwater sampling record.

3.3.2.1 Preparation of Location

Prior to starting the sampling procedure, the area around the existing wells and new monitoring points will be cleared of foreign materials, such as brush, rocks, and debris. These procedures will prevent sampling equipment from inadvertently contacting debris around the monitoring well/point.

3.3.2.2 Water Level and Total Depth Measurements

Prior to removing water from the monitoring well or monitoring point, the static water level will be measured. An electric water level probe or oil-water interface probe will be used to measure the depth to groundwater below the datum to the nearest 0.01 foot. After measuring the static water level, the water level probe will be slowly lowered to the bottom of the monitoring well/point and the depth will be measured to the nearest 0.01 foot. If free-phase product (LNAPL) is present, the total depth of the well from installation records will be used to avoid excessive contamination of the water level probe and cord. Based on these measurements, the volume of water to be purged from the monitoring well/point will be calculated. If free-phase product is encountered, the thickness of the product will be measured with an oil/water interface probe.

3.3.2.3 Monitoring Well/Point Purging

The volume of water contained within the monitoring well/point casing at the time of sampling will be calculated, and at least three times the calculated volume will be removed from the well/point. A peristaltic pump will be used for monitoring well and monitoring point purging, depth permitting, and a Grunfos Redi-Flo II pump, Waterra[®] inertial pump, or bailer will be used to purge all monitoring wells or points in which a peristaltic pump will not work. Clean and contaminated purge waters will be collected in 55-gallon drums provided by the Base. Purged groundwater which does not exhibit an odor, sheen, or other immediate evidence of contamination will be released to the ground at the point of origin. If the water exhibits signs of contamination, it will be transported by Base personnel to the designated waste collection areas at the Base.

If a monitoring well/point is evacuated to a dry state during purging, the monitoring well/point will be allowed to recharge, and the sample will be collected as soon as sufficient water is present in the monitoring well/point to obtain the necessary sample quantity. Sample compositing or sampling over a lengthy period by accumulating small volumes of water at different times to obtain a sample of sufficient volume will not be allowed.

3.3.2.4 Sample Extraction

Dedicated HDPE tubing and a peristaltic pump will be used to extract groundwater samples from monitoring wells/points whenever depth to groundwater permits; otherwise, a Waterra[®] inertial pump or bailer will be used. The tubing, pump, or bailer will be lowered through the casing into the water gently to prevent splashing. The sample will be transferred directly into the appropriate sample container. The water will be carefully poured down the inner walls of the sample bottle to minimize aeration of the sample.

Unless other instructions are given by the USEPA mobile laboratory, sample containers will be completely filled so that no air space remains in the container. Excess water collected during sampling will be disposed of in the same manner as purge water.

3.3.3 Onsite Groundwater Parameter Measurement

As indicated on Table 3.1, many of the groundwater chemical parameters will be measured onsite by USEPA staff. Some of the measurements will be made with direct-reading meters, while others will be made using a HACH[®] portable colorimeter in accordance with specific HACH[®] analytical procedures. These procedures are described in the following subsections.

All glassware or plasticware used in the analyses will have been cleaned prior to sample collection by thoroughly washing with a solution of laboratory-grade, phosphate-free detergent (e.g., Alconox[®]) and water, and rinsing with isopropyl alcohol and deionized water to prevent interference or cross-contamination between

measurements. If concentrations of an analyte are above the range detectable by the titrimetric or colorimetric methods, the analysis will be repeated by diluting the groundwater sample with distilled water until the analyte concentration falls to a level within the range of the method. All rinseate and sample reagents accumulated during groundwater analysis will be collected in glass containers fitted with screw caps. These waste containers will be clearly labeled as to their contents and carefully stored for later transfer by Base personnel to the approved disposal facility.

3.3.3.1 Dissolved Oxygen Measurements

DO measurements will be made using a meter with a downhole oxygen sensor or a sensor in a flow-through cell before and immediately following groundwater sample acquisition. When DO measurements are taken in monitoring wells/points that have not yet been sampled, the existing monitoring wells/points will be purged until DO levels stabilize.

3.3.3.2 pH, Temperature, and Specific Conductance

Because the pH, temperature, and specific conductance of a groundwater sample can change significantly within a short time following sample acquisition, these parameters will be measured in the field in unfiltered, unpreserved, "fresh" water collected by the same technique as the samples taken for laboratory analyses. The measurements will be made in a flow through cell or a clean glass container separate from those intended for laboratory analysis, and the measured values will be recorded in the groundwater sampling record (Figure 3.6).

3.3.3.3 Alkalinity Measurements

Alkalinity in groundwater helps buffer the groundwater system against acids generated through both aerobic and anaerobic biodegradation processes. Alkalinity of the groundwater sample will be measured in the field by experienced USEPA RSKERL scientists via titrimetric analysis using USEPA-approved HACH[®] Method 8221 (0 to 5,000 mg/L as calcium carbonate) or a similar method. Alkalinity of the groundwater sample will also be measured in the laboratory using USEPA method 310.1.

3.3.3.4 Nitrate- and Nitrite-Nitrogen Measurements

Nitrate-nitrogen concentrations are of interest because nitrate can act as an electron acceptor during hydrocarbon biodegradation under anaerobic soil or groundwater conditions. Nitrate-nitrogen is also a potential nitrogen source for biomass formation for hydrocarbon-degrading bacteria. Nitrite-nitrogen is an intermediate byproduct in both ammonia nitrification and in nitrate reduction in anaerobic environments.

Nitrate- and nitrite-nitrogen concentrations in groundwater will be measured in the field by experienced USEPA RSKERL scientists via colorimetric analysis using a HACH[®] DR/700 Portable Colorimeter. Nitrate concentrations in groundwater samples will be analyzed after preparation with HACH[®] Method 8039 (0 to 30.0 mg/L NO₃).

Nitrite concentrations in groundwater samples will be analyzed after preparation with EPA-approved HACH® Method 8507 (0 to 0.35 mg/L NO₂) or a similar method.

3.3.3.5 Carbon Dioxide Measurements

Carbon dioxide concentrations in groundwater will be measured in the field by USEPA RSKERL scientists via titrimetric analysis using HACH® Method 8223 (0 to 250 mg/L as CO₂). Sample preparation and disposal procedures are the same as outlined at the beginning of Section 3.3.3.

3.3.3.6 Sulfate and Sulfide Sulfur Measurements

Sulfate in groundwater is a potential electron acceptor for fuel-hydrocarbon biodegradation in anaerobic environments, and sulfide is resultant after sulfate reduction. A USEPA RSKERL scientist will measure sulfate and sulfide concentrations via colorimetric analysis with a HACH® DR/700 Portable Colorimeter after appropriate sample preparation. EPA-approved HACH® Methods 8051 (0 to 70.0 mg/L SO₄) or similar and 8131 (0.60 mg/L S²⁻) or similar will be used to prepare samples and analyze sulfate and sulfide concentrations, respectively.

3.3.3.7 Total Iron, Ferrous Iron, and Ferric Iron Measurements

Iron is an important trace nutrient for bacterial growth, and different states of iron can affect the redox potential of the groundwater and act as an electron acceptor for biological metabolism under anaerobic conditions. Iron concentrations will be measured in the field via colorimetric analysis with a HACH® DR/700 Portable Colorimeter after appropriate sample preparation. HACH® Method 8008 (or similar) for total soluble iron (0 to 3.0 mg/L Fe³⁺ + Fe²⁺) and HACH® Method 8146 (or similar) for ferrous iron (0 to 3.0 mg/L Fe²⁺) will be used to prepare and quantitate the samples. Ferric iron will be quantitated by subtracting ferrous iron levels from total iron levels.

3.3.3.8 Manganese Measurements

Manganese is a potential electron acceptor under anaerobic environments. Manganese concentrations will be quantitated in the field using colorimetric analysis with a HACH® DR/700 Portable Colorimeter. USEPA approved HACH® Method 8034 (0 to 20.0 mg/L) or similar will be used for quantitation of manganese concentrations. Sample preparation and disposal procedures are outlined earlier in Section 3.3.3.

3.3.3.9 Redox Potential

The redox potential of groundwater is an indication of the relative tendency of a solution to accept or transfer electrons. Redox reactions in groundwater are usually biologically mediated; therefore, the redox potential of a groundwater system depends upon and influences rates of biodegradation. Redox potential can be used to provide real-time data on the location of the contaminant plume, especially in areas undergoing

anaerobic biodegradation. The redox potential of a groundwater sample taken inside the contaminant plume should be somewhat less than that taken in the upgradient location.

The redox potential of a groundwater sample can change significantly within a short time following sample acquisition and exposure to atmospheric oxygen. As a result, this parameter will be measured in the field in unfiltered, unpreserved, "fresh" water collected by the same technique as the samples taken for laboratory analyses. The measurements will be made as quickly as possible in a clean glass container separate from those intended for laboratory analysis or in a flow through cell.

3.4 SAMPLE HANDLING FOR LABORATORY ANALYSIS

This section describes the handling of samples from the time of sampling until the samples are delivered to USEPA field laboratory.

3.4.1 Sample Preservation

The USEPA laboratory support personnel will add any necessary chemical preservatives prior to filling the sample containers. Samples will be prepared for transportation to the analytical laboratory by placing the samples in a cooler containing ice to maintain a shipping temperature of as close to 4 degrees centigrade (°C) as possible. Samples will be delivered promptly to USEPA field laboratory personnel, who will be responsible for shipment of appropriate samples to the RSKERL in Ada, Oklahoma for analysis.

3.4.2 Sample Container and Labels

Sample containers and appropriate container lids will be provided by the USEPA field laboratory (see Appendix A). The sample containers will be filled as described in Section 3.3.3.2.4, and the container lids will be tightly closed. The sample label will be firmly attached to the container side, and the following information will be legibly and indelibly written on the label:

- Facility name;
- Sample identification;
- Sample type (e.g., groundwater, soil);
- Sampling date;
- Sampling time;
- Preservatives added;
- Sample collector's initials; and
- Requested analyses.

3.4.3 Sample Shipment

After the samples are sealed and labeled, they will be packaged for transport to the onsite USEPA field laboratory. The following packaging and labeling procedures will be followed:

- Package sample so that it will not leak, spill, or vaporize from its container;
- Cushion samples to avoid breakage; and
- Add ice to container to keep samples cool.

The packaged samples will be delivered by hand to the USEPA field laboratory. Delivery will occur as soon as possible after sample acquisition.

3.4.4 Chain-of-Custody Control

Chain-of-custody documentation for the shipment of samples from the USEPA field laboratory to the RSKERL analytical laboratory in Ada, Oklahoma, will be the responsibility of the USEPA field personnel.

3.4.5 Sampling Records

In order to provide complete documentation of the sampling event, detailed records will be maintained by the field scientist. At a minimum, these records will include the following information:

- Sample location (facility name);
- Sample identification;
- Sample location map or detailed sketch;
- Date and time of sampling;
- Sampling method;
- Field observations of
 - Sample appearance, and
 - Sample odor;
- Weather conditions;
- Water level prior to purging (groundwater samples, only);
- Total monitoring well/point depth (groundwater samples, only);
- Sample depth (soil samples, only);
- Purge volume (groundwater samples, only);
- Water level after purging (groundwater samples, only);
- Monitoring well/point condition (groundwater samples, only);

- Sampler's identification;
- Field measurements of pH, temperature, DO, and specific conductivity (groundwater samples, only); and
- Any other relevant information.

Groundwater sampling information will be recorded on a groundwater sampling form. Figure 3.6 shows an example of the groundwater sampling record. Soil sampling information will be recorded in the field log book.

3.4.6 Laboratory Analyses

Laboratory analyses will be performed on all groundwater and soil samples as well as the QA/QC samples described in Section 5. The analytical methods for this sampling event are listed in Table 3.1. Prior to sampling, USEPA RSKERL personnel will provide a sufficient number of analyte-appropriate sample containers for the samples to be collected. All containers, preservatives, and shipping requirements will be consistent with USEPA protocol or those reported in Appendix A of this plan.

USEPA laboratory support personnel will specify the necessary QC samples and prepare appropriate QC sample bottles. For samples requiring chemical preservation, preservatives will be added to containers by the laboratory. Containers, ice chests with adequate padding, and cooling media will be provided by USEPA RSKERL laboratory personnel. Sampling personnel will fill the sample containers and return the samples to the field laboratory.

3.5 AQUIFER TESTING

Slug tests will be conducted on selected monitoring wells to estimate the hydraulic conductivity of unconsolidated deposits at the site. This information is required to accurately estimate the velocity of groundwater and contaminants in the shallow saturated zone. A slug test is a single-well hydraulic test used to determine the hydraulic conductivity of an aquifer in the immediate vicinity of the tested well. Slug tests can be used for both confined and unconfined aquifers that have a transmissivity of less than 7,000 (ft²/day). Slug testing can be performed using either a rising head or a falling head test; at this site, both methods will be used in sequence.

3.5.1 Definitions

- **Hydraulic Conductivity (K).** A quantitative measure of the ability of porous material to transmit water; defined as the volume of water that will flow through a unit cross-sectional area of porous or fractured material per unit time under a unit hydraulic gradient.
- **Transmissivity (T).** A quantitative measure of the ability of an aquifer to transmit water. It is the product of the hydraulic conductivity and the saturated thickness.
- **Slug Test.** Two types of testing are possible: rising head and falling head tests. A slug test consists of adding a slug of water or a solid cylinder of known volume to

the well to be tested or removing a known volume of water or cylinder and measuring the rate of recovery of water level inside the well. The slug of a known volume acts to raise or lower the water level in the well.

- **Rising Head Test.** A test used in an individual well within the saturated zone to estimate the hydraulic conductivity of the surrounding formation by lowering the water level in the well and measuring the rate of recovery of the water level. The water level may be lowered by pumping, bailing, or removing a submerged slug from the well.
- **Falling Head Test.** A test used in an individual well to estimate the hydraulic conductivity of the surrounding formation by raising the water level in the well by insertion of a slug or quantity of water, and then measuring the rate of drop in the water level.

3.5.2 Equipment

The following equipment will be used to conduct a slug test:

- Teflon[®], PVC, or metal slugs;
- Nylon or polypropylene rope;
- Electric water level indicator;
- Pressure transducer/sensor;
- Field logbook/forms; and
- Automatic data recording instrument (such as the Hermit Environmental Data Logger[®], In-Situ, Inc. Model SE1000B, or equivalent).

3.5.3 General Test Methods

Aquifer hydraulic conductivity tests (slug tests) are accomplished by either removal of a slug or quantity of water (rising head) or introduction of a slug (falling head), and then allowing the water level to stabilize while taking water level measurements at closely spaced time intervals.

Because hydraulic testing will be completed on existing wells, it will be assumed that the wells were properly developed and that water levels have stabilized. Slug testing will proceed only after multiple water level measurements over time show that static water levels are in equilibrium. During the slug test, the water level change should be influenced only by the introduction (or removal) of the slug volume. Other factors, such as inadequate well development or extended pumping may lead to inaccurate results; in addition, slug tests will not be performed on wells with free product. The field scientist will determine when static equilibrium has been reached in the well. The pressure transducer, slugs, and any other downhole equipment will be

decontaminated prior to and immediately after the performance of each slug test using the procedures described in Section 3.3.1.1.

3.5.4 Falling Head Test

The falling head test is the first step in the two-step slug testing procedure. The following paragraphs describe procedures to be followed during performance of the falling head test.

1. Decontaminate all downhole equipment prior to initiating the test.
2. Open the well. Where wells are equipped with watertight caps, the well should be unsealed at least 24 hours prior to testing to allow the water level to stabilize. The protective casing will remain locked during this time to prevent vandalism.
3. Prepare the aquifer slug test data form (Figure 3.7) with entries for:
 - Borehole/well number,
 - Project number,
 - Project name,
 - Aquifer testing team,
 - Climatic data,
 - Ground surface elevation,
 - Top of well casing elevation,
 - Identification of measuring equipment being used,
 - Page number,
 - Static water level, and
 - Date.
4. Measure the static water level in the well to the nearest 0.01 foot.
5. Lower the decontaminated pressure transducer into the well and allow the displaced water to return to its static level. This can be determined by periodic water level measurements until the static water level in the well is within 0.01 foot of the original static water level.

6. Lower the decontaminated slug into the well to just above the water level in the well.
7. Turn on the data logger and quickly lower the slug below the water table, being careful not to disturb the pressure transducer. Follow the owner's manual for proper operation of the data logger.
8. Terminate data recording when the water level stabilizes in the well. The well will be considered stabilized for termination purposes when it has recovered 80 to 90 percent from the initial displacement.

3.5.5 Rising Head Test

After completion of the falling head test, the rising head test will be performed. The following paragraphs describe the rising head slug test procedure.

1. Measure the water level in the well to the nearest 0.01 foot to ensure that it has returned to the static water level.
2. Initiate data recording and quickly withdraw the slug from the well. Follow the owner's manual for proper operation of the data logger.
3. Terminate data recording when the water level stabilizes in the well, and remove the pressure transducer from the well and decontaminate. The well will be considered stabilized for termination purposes when it has recovered 80 to 90 percent from the initial displacement.

3.5.6 Slug Test Data Analysis

Data obtained during slug testing will be analyzed using AQTESOLV™ and the method of Hvorslev (1951) for confined aquifers or the method of Bouwer and Rice (1976) and Bouwer (1989) for unconfined conditions.

SECTION 4

REMEDIAL OPTION EVALUATION AND TS REPORT

Upon completion of field work, numerical and analytical groundwater models will be used to determine the fate and transport of fuel hydrocarbons and chlorinated solvents dissolved in groundwater at the sites. Based upon model predictions of contaminant concentration and distribution through time, and upon potential exposure pathways, the potential risk to human health and the environment will be assessed. If it is shown that intrinsic remediation of BTEX compounds at the sites is sufficient to reduce the potential risk to human health and the environment to acceptable levels, Parsons ES will recommend implementation of the intrinsic remediation option. If intrinsic remediation is chosen, Parsons ES will prepare site-specific, long-term monitoring plans that will specify the location of point-of-compliance monitoring wells and sampling frequencies.

If the intrinsic remediation remedial option is deemed inappropriate for use at these sites, institutional controls such as groundwater or land use restrictions will be evaluated to determine if they will be sufficient to reduce the risk to human health and the environment to acceptable levels. If institutional controls are inappropriate, remedial options which could reduce risks to acceptable levels will be evaluated and the most appropriate remedial options will be recommended. Potential remedial options include, but are not limited to, free-product recovery, groundwater pump-and-treat, enhanced biological treatment, bioventing, air sparging, and *in situ* reactive barrier walls. The reduction in dissolved BTEX that should result from remedial activities will be used to produce new input files for the groundwater models. The models will then be used to predict the BTEX plume (and risk) reduction that should result from remedial actions.

Upon completion of modeling and remedial option selection, a TS report detailing the results of the modeling and remedial option selection will be prepared. This report will follow the outline presented in Table 4.1 and will contain an introduction, site descriptions, identification of remediation objectives, description of remediation alternatives, an analysis of remediation alternatives, and the recommended remedial approach for each site. This report will also contain the results of the site characterization activities described herein and a description of the models developed for each site.

TABLE 4.1
EXAMPLE TS REPORT OUTLINE
INTRINSIC REMEDIATION TS
WESTOVER ARB, MASSACHUSETTS

INTRODUCTION

- Scope and Objectives
- Site Background

SITE CHARACTERIZATION ACTIVITIES

- Sampling and Aquifer Testing Procedures

PHYSICAL CHARACTERISTICS OF THE STUDY AREA

- Surface Features
- Regional Geology and Hydrogeology
- Site Geology and Hydrogeology
- Climatological Characteristics

NATURE AND EXTENT OF CONTAMINATION

- Source Characterization
- Soil Chemistry
 - Residual Contamination
 - Total Organic Carbon
- Ground Water Chemistry
 - LNAPL Contamination
 - Dissolved Contamination
 - Ground Water Geochemistry
 - Expressed Assimilative Capacity

GROUND WATER MODEL

- Model Description
- Conceptual Model Design and Assumptions
- Initial Model Setup
- Model Calibration
- Sensitivity Analysis
- Model Results
- Conclusions

COMPARATIVE ANALYSIS OF REMEDIAL ALTERNATIVES

- Remedial Alternative Evaluation Criteria
 - Long-Term Effectiveness
 - Implementability (Technical, Administrative)
 - Cost (Capital, Operating, Present Worth)
- Factors Influencing Alternatives Development
 - Program Objectives
 - Contaminant Properties
 - Site-Specific Conditions
- Brief Description of Remedial Alternatives
 - Intrinsic Remediation with Long-Term Monitoring
 - Other Alternatives
- Evaluation of Alternatives
- Recommended Remedial Approach

TABLE 4.1
EXAMPLE TS REPORT OUTLINE
INTRINSIC REMEDIATION TS
WESTOVER ARB, MASSACHUSETTS

LONG-TERM MONITORING PLAN

Overview
Monitoring Networks
Ground Water Sampling

CONCLUSIONS AND RECOMMENDATIONS

APPENDICES: Supporting Data and Documentation
Site-Specific Bioplume II Model Input and Results

SECTION 5

QUALITY ASSURANCE/QUALITY CONTROL

Field QA/QC procedures will include collection of field duplicates and rinseate, field and trip blanks; decontamination of all equipment that contacts the sample medium before and after each use; use of analyte-appropriate containers; and chain-of-custody procedures for sample handling and tracking. All samples to be transferred to the analytical laboratory for analysis will be clearly labeled to indicate sample number, location, matrix (e.g., groundwater), and analyses requested. Samples will be preserved in accordance with the analytical methods to be used, and water sample containers will be packaged in coolers with ice to maintain a temperature of as close to 4°C as possible.

All field sampling activities will be recorded in a bound, sequentially paginated field notebook in permanent ink. All sample collection entries will include the date, time, sample locations and numbers, notations of field observations, and the sampler's name and signature. Field QC samples will be collected in accordance with the program described below, and as summarized in Table 5.1.

QA/QC sampling will include collection and analysis of duplicate groundwater and soil samples, rinseate blanks, field/trip blanks, and matrix spike samples. Internal laboratory QC analyses will involve the analysis of laboratory control samples (LCSs) and laboratory method blanks (LMBs). QA/QC objectives for each of these samples, blanks, and spikes are described below.

Soil and groundwater samples collected with the Geoprobe[®] sampler should provide sufficient volume for some duplicate analyses. Refer to Table 3.1 and Appendix A for further details on sample volume requirements.

One rinseate sample will be collected for every 10 or fewer groundwater samples collected from existing wells. Because disposable bailers may be used for this sampling event, the rinseate sample will consist of a sample of distilled water poured into a new disposable bailer and subsequently transferred into a sample container provided by the laboratory. Rinseate samples will be analyzed for VOCs only.

A field blank will be collected for every 20 or fewer groundwater samples (both from groundwater monitoring point and groundwater monitoring well sampling events) to assess the effects of ambient conditions in the field. The field blank will consist of a sample of distilled water poured into a laboratory-supplied sample container while sampling activities are underway. The field blank will be analyzed for VOCs.

TABLE 5.1
QA/QC SAMPLING PROGRAM
INTRINSIC REMEDIATION TS
WESTOVER ARB, MASSACHUSETTS

QA/QC Sample Types	Frequency to be Collected and/or Analyzed	Analytical Methods
Duplicates	5 Groundwater and 3 Soil Samples (10%)	VOCs, TPH
Rinseate Blanks	3 Samples (5% of Groundwater Samples)	VOCs
Field Blanks	3 Samples (5% of Groundwater Samples)	VOCs
Trip Blanks	One per shipping cooler containing VOC samples	VOCs
Matrix Spike Samples	Once per sampling event	VOCs
Laboratory Control Sample	Once per method per medium	Laboratory Control Charts (Method Specific)
Laboratory Method Blanks	Once per method per medium	Laboratory Control Charts (Method Specific)

A trip blank will be analyzed to assess the effects of ambient conditions on sampling results during the transportation of samples. The trip blank will be prepared by the laboratory. A trip blank will be transported inside each cooler which contains samples for VOC analysis. Trip blanks will be analyzed for VOCs.

Matrix spikes will be prepared in the laboratory and used to establish matrix effects for samples analyzed for VOCs.

LCSs and LMBs will be prepared internally by the laboratory and will be analyzed each day samples from the site are analyzed. Samples will be reanalyzed in cases where the LCS or LMB are out of the control limits. Control charts for LCSs and LMBs will be developed by the laboratory and monitored for the analytical methods used.

SECTION 6

REFERENCES

- Borden, R.C., and Bedient, P.B. 1986. "Transport of Dissolved Hydrocarbons Influenced by Oxygen Limited Biodegradation - Theoretical Development," *Water Resources Research*, vol. 22, no. 13. p. 1973-82.
- Bouwer, H., 1989, The Bouwer and Rice slug test - an update: *Ground Water*, 27(3), p. 304-309.
- Bouwer, H., and Rice, R.C., 1976, A slug test for determining hydraulic conductivity of unconfined aquifers with completely or partially penetrating wells: *Water Resources Research*, 12(3), p. 423-428.
- Bruce, L., Miller, T., and Hockman, B., 1991, Solubility versus equilibrium saturation of gasoline compounds - a method to estimate fuel/water partition coefficient using solubility or K_{oc} ... In, A. Stanley (editor), NWWAI/API Conference on Petroleum Hydrocarbons in Ground water: NWT/API, p. 571-582.
- CH2M Hill, 1982, U.S. Air Force Installation Restoration Program Records Search for Westover Air Force Base, April 1982.
- Cline, P.V., Delfino, J.J., and Rao, P.S.C., 1991, Partitioning of aromatic constituents into water from gasoline and other complex solvent mixtures: *Environmental Science and Technology*: v. 17, no. 4, p. 227-231.
- Engineering-Science, Inc. (ES), 1986, Installation Restoration Program, Phase II - Technical Operations Plan, September 1986.
- Engineering-Science, Inc. (ES), 1988, Installation Restoration Program, Phase II - Confirmation/Quantification Stage 2. Final Report, October 1988.
- Engineering-Science, Inc. (ES), 1993, *Health and Safety Plan for the Bioplume Modeling Initiative*. Prepared for the Air Force Center for Environmental Excellence, Environmental Restoration Division, USAF Contract F41624-92-D-8036.
- Freeze, R.A. and Cherry, J.A., 1979, *Groundwater*; Prentice-Hall, Inc., Englewood Cliffs, N.J.

- Hvorslev, M. J., 1951, Time Lag and Soil Permeability in Ground-Water Observations: United States Corps of Engineers Waterways Experiment Station Bulletin 36, Vicksburg, Mississippi. 50 p.
- Hvorslev, M. J., 1951, *Time Lag and Soil Permeability in Ground-Water Observations*: United States Corps of Engineers Waterways Experiment Station Bulletin 36, Vicksburg, Mississippi. 50p.
- Lee, M.D. 1988. "Biorestitution of Aquifers Contaminated with Organic Compounds." *CRC Critical Reviews in Environmental Control*, v. 18. p. 29-89.
- O'Brien and Gere Engineers, Inc. 1993, Installation Restoration Program, Health and Safety Plan; Site FT-03 "Christmas Tree" Fire Training Area, Site FT-08 Current Fire Training Area, SS-19 Aqua Systems Site, SS-16 Hangar Apron Area, April 1993.
- O'Brien and Gere Engineers, Inc. 1994, Installation Restoration Program, Supplemental Remedial Investigation/Feasibility Study; Site FT-03 "Christmas Tree" Fire Training Area, Site FT-08 Current Fire Training Area, September 1994.
- O'Brien and Gere Engineers, Inc. 1995, Summary Report, Groundwater Monitoring Site FT-03 "Christmas Tree" Fire Training Area, February 1995.
- Rifai, H.S., Bedient, P.B., Wilson, J.T., Miller, K.M., and Armstrong, J.M. 1988. "Biodegradation Modeling at Aviation Fuel Spill Site," *Journal of Environmental Engineering*, v. 114, no. 5, p. 1007-1029.
- Thomas, 1987
- UNC Geotech, 1991, Final Remedial Investigations Report, prepared for 439th Military Airlift Wing, 1991.
- UNC Geotech, Remedial Investigations/Feasibility Studies Work Plan, prepared for 439th Military Airlift Wing.
- USAFTEC, 1986
- US Geological Survey (USGS), 1979, 7.5 Minute Quadrangle Map of the Springfield North Quadrangle, Massachusetts.
- van Genuchten, M. Th. and Alves, W. J., 1982, *Analytical Solutions of the One-Dimensional Convective-Dispersive Solute Transport Equation*: US Department of Agriculture, Technical Bulletin Number 1661, 151p.
- Weston 1984, Installation Restoration Program Final Report Phase II - Problem Confirmation Study, Westover Air Force Base, May 1984.
- Wexler, 1992.
- Westover 2000, 1993.

Wiedemeier, Todd H., Downey, Douglas C., Wilson, John T., Kampbell, Donald H., Miller, Ross N., and Hansen, Jerry E., 1995, Draft *Technical Protocol for Implementing the Intrinsic Remediation (Natural Attenuation) with Long-term Monitoring Option for Dissolved-phase Fuel Contamination in Ground Water*. Prepared by the Air Force Center for Environmental Excellence.

APPENDIX A

CONTAINERS, PRESERVATIVES, PACKAGING, AND SHIPPING

REQUIREMENTS FOR GROUNDWATER SAMPLES

APPENDIX A

Matrix	Analysis	Method/Reference	Comments	Data Use	Recommended Frequency of Analysis	Sample Volume, Sample Container, Sample Preservation	Field or Fixed-Base Laboratory
Soil	Volatile organics	Gas chromatography/mass spectrometry method SW8240.	Handbook method	Data is used to determine the extent of chlorinated solvent and aromatic hydrocarbon contamination, contaminant mass present, and the need for source removal	Each sampling round	Collect 100 g of soil in a glass container with Teflon®-lined cap; cool to 4°C	Fixed-base
Soil	Dehydrogenase enzyme activity (optional)	Colorimetric RSKSOP-100	Reduction of added triphenyltetrazolium chloride by soil microbes is measured colorimetrically; analyze immediately	An indicator of the presence of soil microbes, which are necessary for bioremediation to occur	At the beginning of the project	Collect 100 g of soil in a glass container	Field
Soil	Aromatic hydrocarbons (benzene, toluene, ethylbenzene, and xylene [BTEX]; trimethylbenzene isomers)	Purge and trap gas chromatography (GC) method SW8020	Handbook method modified for field extraction of soil using methanol	Data is used to determine the extent of soil contamination, the contaminant mass present, and the need for source removal	Each sampling round	Collect 100 g of soil in a glass container with Teflon-lined cap; cool to 4°C	Fixed-base
Soil	Total hydrocarbons, volatile and extractable	GC method SW8015 [modified]	Handbook method; reference is the California LUFT manual	Data are used to determine the extent of soil contamination, the contaminant mass present, and the need for source removal	Each sampling round	Collect 100 g of soil in a glass container with Teflon-lined cap; cool to 4°C	Fixed-base

Matrix	Analysis	Method/Reference	Comments	Data Use	Recommended Frequency of Analysis	Sample Volume, Sample Container, Sample Preservation	Field or Fixed-Base Laboratory
Soil	Total organic carbon (TOC)	SW9060 modified for soil samples	Procedure must be accurate over the range of 0.5-15 percent TOC	Relatively high amounts of TOC may be indicative of a reducing environment and may indicate the need for analysis of electron acceptors associated with that environment; the rate of migration of petroleum contaminants in groundwater is dependent upon the amount of TOC in the saturated zone soil; the rate of release of petroleum contaminants from the source into groundwater is dependent (in part) on the amount of TOC in the vadose zone soil	At initial sampling	Collect 100 g of soil in a glass container with Teflon-lined cap; cool to 4°C	Fixed-base Laboratory
Soil	Moisture	ASTM D-2216	Handbook method	Data are used to correct soil sample analytical results for moisture content (e.g., report results on a dry weight basis)	Each soil sampling round	Use a portion of soil sample collected for another analysis	Fixed-base
Soil	Grain size distribution	ASTM D422	Procedure provides a distribution of grain size by sieving	Data are used to infer hydraulic conductivity of aquifer, and are used in calculating sorption of contaminants	One time during life of project	Collect 250 g of soil in a glass or plastic container; preservation is unnecessary	Fixed-base
Soil gas	Carbon dioxide content of soil gas	Nondispersive infrared instrument operating over the range of approximately 0.1-15 percent	Soil gas carbon dioxide may be produced by the degradation of petroleum hydrocarbons	Data used to understand the carbon dioxide concentration gradient with depth and to infer the biological degradation of petroleum contaminants	Each sampling round	N/A	Field

Matrix	Analysis	Method/Reference	Comments	Data Use	Recommended Frequency of Analysis	Sample Volume, Sample Container, Sample Preservation	Field or Fixed-Base Laboratory
Soil gas	Oxygen content of soil gas	Electrochemical oxygen meter operating over the range of 0-25 percent of oxygen in the soil gas sample	The concentration of soil gas oxygen is often related to the amount of biological activity, such as the degradation of petroleum hydrocarbons; soil gas oxygen concentrations may decrease to the point where anaerobic pathways dominate	Data are used to understand the oxygen concentration gradient with depth and to determine the presence or absence of aerobic degradation processes	Each sampling round	N/A	Field
Soil gas	Methane content of soil gas	Total combustible hydrocarbon meter using a platinum catalyst with a carbon trap, and operating in the low parts per million volume (ppmv) range	Methane is a product of the anaerobic degradation of petroleum hydrocarbons	Soil gas methane can be used to locate contaminated soil and to determine the presence of anaerobic processes; see discussion of data use for methane in water	Each sampling round	N/A	Field
Soil gas	Fuel hydrocarbon vapor content of soil gas	Total combustible hydrocarbon meter operating over a wide ppmv range	Soil gas hydrocarbons indicate the presence of these contaminants in the soil column	Data used to understand the petroleum hydrocarbon concentration gradient with depth and to locate the most heavily contaminated soils	Each sampling round	N/A	Field
Water	Ferrous (Fe ²⁺)	Colorimetric A3500-Fe D	Field only	May indicate an anaerobic degradation process due to depletion of oxygen, nitrate, and manganese	Each sampling round	Collect 100 ml of water in a glass container; acidify with hydrochloric acid per method	Field

Matrix	Analysis	Method/Reference	Comments	Data Use	Recommended Frequency of Analysis	Sample Volume, Sample Container, Sample Preservation	Field or Fixed-Base Laboratory
Water	Ferrous (Fe ²⁺)	Colorimetric HACH Method # 8146	Alternate method; field only	Same as above	Each sampling round	Collect 100 ml of water in a glass container	Field
Water	Total Iron	Colorimetric HACH Method # 8008	Field only		Each sampling round	Collect 100mL of water in a glass container	Field
Water	Manganese	Colorimetric HACH Method # 8034	Field only		Each sampling round	Collect 100 mL of water in a glass container	Field
Water	Chloride	Mercuric nitrate titration, A4500-Cl ⁻ C	Ion chromatography (IC) method E300 or method SW9050 may also be used	General water quality parameter used as a marker to verify that site samples are obtained from the same groundwater system.	Each sampling round	Collect 250 mL of water in a glass container	Field
Water	Chloride	HACH Chloride test kit model 8-P	Silver nitrate titration	Same as above	Each sampling round	Collect 100mL of water in a glass container	Field
Water	Oxygen	Dissolved oxygen meter	Refer to method A4500 for a comparable laboratory procedure	The oxygen concentration is a data input to the Bioplume model, concentrations less than 1 mg/L generally indicate an anaerobic pathway	Each sampling round	Collect 300 mL of water in biochemical oxygen demand bottles, analyze immediately, alternate, measure dissolved oxygen <i>in situ</i>	Field
Water	Conductivity	E120.1/SW9050, direct reading meter	Protocols/Handbook methods	General water quality parameter used as a marker to verify that site samples are obtained from the same groundwater system	Each sampling round	Collect 100-250 mL of water in a glass or plastic container	Field
Water	Alkalinity	HACH Alkalinity test kit model ALAP-MG-L	Phenolphthalein method	General water quality parameter used (1) as a marker to verify that all site samples are obtained from the same groundwater system and (2) to measure the buffering capacity of groundwater	Each sampling round	Collect 100ml. of water in glass container	Field

Matrix	Analysis	Method/Reference	Comments	Data Use	Recommended Frequency of Analysis	Sample Volume, Sample Container, Sample Preservation	Field or Fixed-Base Laboratory
Water	Alkalinity	A2320, titrimetric; E310.2, colorimetric	Handbook method	Same as above	Each sampling round	Collect 250 mL of water in a glass or plastic container, analyze within 6 hours	Field
Water	Nitrate (NO_3^{-1})	IC method E300 or method SW9056, colorimetric, method E353.2	Method E300 is a Handbook method; method SW9056 is an equivalent procedure Colorimetric	Substrate for microbial respiration if oxygen is depleted	Each sampling round	Collect up to 40 mL of water in a glass or plastic container, cool to 4°C, analyze within 48 hours	Fixed-base
Water	Nitrate (NO_3^{-1})	HACH method # 8039 for high range method # 8192 for low range HACH method #8040	Colorimetric	Same as above	Each sampling round	Collect 100mL of water in a glass container	Field
Water	Nitrite (NO_2^{-})	IC method E300 or method SW9056	Colorimetric	Substrate for microbial respiration if oxygen is depleted	Each sampling round	Collect 100mL of water in a glass container	Field
Water	Sulfate (SO_4^{-2})	HACH method # 8051	Method E300 is a Handbook method; method SW9056 is an equivalent procedure Colorimetric	Substrate for anaerobic microbial respiration	Each sampling round	Collect up to 40 mL of water in a glass or plastic container, cool to 4°C	Fixed-base
Water	Sulfate (SO_4^{-2})	HACH method # 8131	Colorimetric	Same as above	Each sampling round	Collect up to 40 mL of water in a glass or plastic container, cool to 4°C	Field
Water	Dissolved sulfide (S^{-2})	HACH method # 8131	Colorimetric	Product of sulfate-based anaerobic microbial respiration; analyze in conjunction with sulfate analysis	Each sampling round	Collect 100 mL of water in a glass container, analyze immediately	Field

Matrix	Analysis	Method/Reference	Comments	Data Use	Recommended Frequency of Analysis	Sample Volume, Sample Container, Sample Preservation	Field or Fixed-Base Laboratory
Water	Ethane, ethene	RSKSOP-114 (cont'd)	Ethane and ethene are analyzed in addition to the other analytes only if chlorinated hydrocarbons are contaminants suspected of undergoing biological transformation	Ethane and ethene are products of the biotransformation of chlorinated hydrocarbons under anaerobic conditions. The presence of these chemicals may indicate that anaerobic degradation is occurring			
Water	Carbon dioxide	HACH test kit model CA-23 or CHEMetrics Method 4500	Titrimetric; alternate method	The presence of free carbon dioxide dissolved in groundwater is unlikely because of the carbonate buffering system of water, but if detected, the carbon dioxide concentrations should be compared with background to determine whether they are elevated; elevated concentrations of carbon dioxide could indicate an aerobic mechanism for bacterial degradation of petroleum	Each sampling round	Collect 100 mL of water in a glass container	Field

Matrix	Analysis	Method/Reference	Comments	Data Use	Recommended Frequency of Analysis	Sample Volume, Sample Container, Sample Preservation	Field or Fixed-Base Laboratory
Water	Aromatic hydrocarbons (BTEX, trimethylbenzene isomers)	Purge and trap GC method SW8020	Handbook method; analysis may be extended to higher molecular weight alkyl benzenes	Method of analysis for BTEX, which is the primary target analyte for monitoring natural attenuation; BTEX concentrations must also be measured for regulatory compliance; method can be extended to higher molecular weight alkyl benzenes; trimethylbenzenes are used to monitor plume dilution if degradation is primarily anaerobic	Each sampling round	Collect water samples in a 40 mL VOA vial; cool to 4°C; add hydrochloric acid to pH 2	Fixed-base Laboratory
Water	Total hydrocarbons, volatile and extractable	GC method SW8015 [modified]	Handbook method; reference is the California LUFT manual	Data used to monitor the reduction in concentrations of total fuel hydrocarbons (in addition to BTEX) due to natural attenuation; data also used to infer presence of an emulsion or surface layer of petroleum in water sample, as a result of sampling	One time per year or as required by regulations	Volatile hydrocarbons—collect water samples in a 40 mL VOA vial; cool to 4°C; add hydrochloric acid to pH 2 Extractable hydrocarbons—collect 1 L of water in a glass container; cool to 4°C; add hydrochloric acid to pH 2	Fixed-base Laboratory
Water	Polycyclic aromatic hydrocarbons (PAHs) (optional)	GC/mass spectroscopy method SW8270; high-performance liquid chromatography method SW8310	Analysis needed only for several samples per site	PAHs are components of fuel and are typically analyzed for regulatory compliance; data on their concentrations are not used currently in the evaluation of natural attenuation	At initial sampling and at site closure or as required by regulations	Collect 1 L of water in a glass container; cool to 4°C	Fixed-base Laboratory

Matrix	Analysis	Method/Reference	Comments	Data Use	Recommended Frequency of Analysis	Sample Volume, Sample Container, Sample Preservation	Field or Fixed-Base Laboratory
Water	Total fuel carbon (optional)	Purge and trap GC method SW8020 modified to measure all volatile aromatic hydrocarbons present in the sample	A substitute method for measuring total volatile hydrocarbons; reports amount of fuel as carbon present in the sample; method available from the U.S. EPA Robert S. Kerr Laboratory Handbook method	Data used to monitor the reduction in concentrations of total fuel hydrocarbons (in addition to BTEX) due to natural attenuation	At initial sampling and at site closure	Collect 40 mL of water in glass vials with Teflon-lined caps; add sulfuric acid to pH 2; cool to 4°C	Fixed-base Laboratory
Water	Volatile Organics	GS/MS method SW8240		Method of analysis for chlorinated solvents and aromatic hydrocarbons for evaluation of cometabolic degradation; measured for regulatory compliance when chlorinated solvents are known site contaminants	Each sampling round	Collect water samples in a 40 mL VOA vial; cool to 4°C; add hydrochloric acid to pH 2	Fixed-base
Water	Dissolved organic carbon (DOC) (optional)	A5310 C	An oxidation procedure whereby carbon dioxide formed from DOC is measured by an infrared spectrometer. The minimum detectable amount of DOC is 0.05 mg/L	An indirect index of microbial activity	Each sampling round	Collect 100 mL of water in an amber glass container with Teflon-lined cap; preserve with sulfuric acid to pH less than 2; cool to 4°C	Fixed-base
Water	pH	E150.1/SW9040, direct reading meter	Protocols/Handbook methods	Aerobic and anaerobic processes are pH-sensitive	Each sampling round	Collect 100-250 mL of water in a glass or plastic container; analyze immediately	Field

Matrix	Analysis	Method/Reference	Comments	Data Use	Recommended Frequency of Analysis	Sample Volume, Sample Container, Sample Preservation	Field or Fixed-Base Laboratory
Water	Temperature	E170.1	Field only	Well development	Each sampling round	N/A	Field
Water	Redox potential	A2580 B	Measurements are made with electrodes; results are displayed on a meter, samples should be protected from exposure to atmospheric oxygen	The redox potential of groundwater influences and is influenced by the nature of the biologically mediated degradation of contaminants; the redox potential of groundwater may range from more than 200 mV to less than -400 mV	Each sampling round	Collect 100-250 mL of water in a glass container, filling container from bottom; analyze immediately	Field

NOTES:

1. "HACH" refers to the HACH Company catalog, 1990.
2. "A" refers to *Standard Methods for the Examination of Water and Wastewater*, 18th edition, 1992.
3. "E" refers to *Methods for Chemical Analysis of Water and Wastes*, U.S. Environmental Protection Agency, March 1979.
4. "Protocols" refers to the AFCEE *Environmental Chemistry Function Installation Restoration Program Analytical Protocols*, 11 June 1992.
5. "Handbook" refers to the AFCEE *Handbook to Support the Installation Restoration Program (IRP) Remedial Investigations and Feasibility Studies (RI/FS)*, September 1993.
6. "SW" refers to the *Test Methods for Evaluating Solid Waste, Physical, and Chemical Methods*, SW-846, U.S. Environmental Protection Agency, 3rd edition, 1986.
7. "ASTM" refers to the *American Society for Testing and Materials*, current edition.
8. "RSKSOP" refers to *Robert S. Kerr (Environmental Protection Agency Laboratory) Standard Operating Procedure*.
9. "LUFT" refers to the state of California *Leaking Underground Fuel Tank Field Manual*, 1988 edition.
10. *International Journal of Environmental Analytical Chemistry*, Volume 36, pp. 249-257, "Dissolved Oxygen and Methane in Water by a Gas Chromatography Headspace Equilibration Technique," by D. H. Kambell, J. T. Wilson, and S. A. Vandegrift.

APPENDIX B
ADDITIONAL SITE DATA

APPENDIX B - 1a

**Well Installation Logs
Site FT-08**

Source: ES, 1986.

DATE
 STARTED 11-7-86
 FINISHED 11-7-86
 SHEET 1 OF 3

EMPIRE
SOIL INVESTIGATIONS INC. SUBSURFACE LOG

HOLE NO. CF-1
 SURF. ELEV. _____
 G. W. DEPTH See Notes

PROJECT Westover Air Force Base LOCATION Chicopee, Massachusetts
Current Fire Department Training Area

DEPTH	SAMPLE NO	BLOWS ON SAMPLER					*	SOIL OR ROCK CLASSIFICATION	6" dia. Guard Pipe w/Locking Cap -3"
		0-6	6-12	12-18	18-24	N			
0	1	1	2	1	3		TOPSOIL 0.4' LOAM to 1.0'		
		1				0	Brown medium-fine SAND (Damp)	Bentonite/Cement Grout	
5	2	8	18	15	23	0.9	Brown coarse-fine SAND (Wet-Firm)		
		17						2" dia. Solid PVC Riser Pipe	
10	3	8	8	10	18	0.3	similar meth. chlor. = 0		
		13							
15	4	10	10	13	23	0.4	Rust coarse-fine SAND & fine GRAVEL (Wet-Firm)		
		7							
20	5	9	16	17	33	0.5	Brown fine SAND (Wet-Compact) meth. chlor. = 0		
		20							
25	6	13	17	25	42	0.1	Brown medium-fine SAND (Wet-Compact)		
		33							
30	7	16	18	18	36	0.1	Brown fine SAND (Wet-Compact) meth. chlor. = 0		
		30							
35	8	35	30	34	64	0.1	similar, Very Compact		
		40							

*Photovac Reading in ppm above background

40.0' 11-7-86
11-10-86

N = No blows to drive 2 " spoon 12 " with 140 lb. pin wt. falling 30 " per blow. CLASSIFICATION Visual by Driller
 C = No blows to drive _____ " casing _____ " with _____ lb. weight falling _____ " per blow.
 METHOD OF INVESTIGATION 6" dia. Flush Joint Casing

DATE

STARTED 11-10-86

FINISHED 11-12-86

SHEET 2 OF 3



SUBSURFACE LOG

HOLE NO. CF-1 cont'd

SURF. ELEV. _____

G. W. DEPTH _____

PROJECT Westover Air Force Base

LOCATION Chicopee, Massachusetts

Current Fire Department Training Area

DEPTH	SAMPLES	SAMPLE NO	BLOWS ON SAMPLER					*	SOIL OR ROCK CLASSIFICATION	NOTES
			0-6	6-12	12-18	18-24	24-N			
40	/	9	22	27	29	52	0.2	On 11-10-86, a.m., water at 7.1', casing at 40.0' meth. chlor. = 0 Brown fine SAND w/thin Clay seams (Wet-Very Compact)	Bentonite/Cement Grout	
			30							
45	/	10	6	7	9	16	0.4	Brown coarse-fine SAND (Wet-Firm)		
			10							
50	/	11	8	7	9	16	0.3	similar meth. chlor. = 0		
			8							
55	/	12	6	6	8	14		similar w/little fine gravel (Wet-Firm)		
			11							
60	/	13	6	4	7	11	0.1	Brown/Grey fine SAND w/lenses of coarse Sand (Wet-Firm) meth. chlor. = 0		
			8							
65	/	14	6	8	9	17	0.1	Grey fine SAND, Some Silt, trace clay (Wet-Firm) 67.0' - 11-10-86 11-12-86	Bentonite Seal	
			11							
70	/	15	7	11	13	24	0	On 11-12-86, a.m., water at 14.1', casing at 65.0', hole open to 65.0'. Grey fine SAND (Wet-Firm) meth. chlor. = 0	4Q Sand	
			17							
75	/	16	9	9	11	20	0.1	similar	2" dia PVC Well Screen, 0.02" Slot Size	
			11							
80	/							*Photovac Reading in ppm above background		

N = No blows to drive 2 " spoon 12 " with 140 lb. pin wt. falling 30 " per blow. CLASSIFICATION Visual by Driller
 C = No blows to drive _____ " casing _____ " with _____ lb. weight falling _____ " per blow.
 METHOD OF INVESTIGATION 6" dia Flush Joint Casing

DATE

STARTED 11-12-86

FINISHED 11-13-86

SHEET 3 OF 3



SUBSURFACE LOG

HOLE NO. CE-1 cont'd

SURF. ELEV. _____

G. W. DEPTH _____

PROJECT Westover Air Force Base
Current Fire Department Training Area

LOCATION Chicopee, Massachusetts

DEPTH	SAMPLE NO	BLOWS ON SAMPLER					*	SOIL OR ROCK CLASSIFICATION	NOTES
		0-6	6-12	12-18	18-24	N			
80	17	8	9	12	21		Grey Clayey SAND (Wet-Firm) meth. chlor. = 0		
		13				0			
85	18	5	4	5	9		Grey varved CLAY, SAND & SILT (Wet-Loose) 85.0' ¹¹⁻¹²⁻⁸⁶ / ₁₁₋₁₃₋₈₆		
		5				0.1			
90	19	5	4	4	8		similar meth. chlor. = 0		
		4				0.2			
							Boring Terminated @ 92.0'	3-3 1/2" dia. Steel Guard Posts installed around well. On 1-23-87, water at 6.3' below top of guard pipe.	
95									
100									

*Photovac Reading in ppm above background

N = No blows to drive 2 " spoon 12 " with 140 lb. pin wt. falling 30 " per blow. CLASSIFICATION Visual by Drill

C = No blows to drive _____ " casing _____ " with _____ lb. weight falling _____ " per blow.

METHOD OF INVESTIGATION 6" dia. Flush Joint Casing

DATE

STARTED 11-17-86

FINISHED 11-17-86

SHEET 1 OF 1



SUBSURFACE LOG

HOLE NO. CF-1A

SURF. ELEV.

G. W. DEPTH N/A

PROJECT Westover Air Force Base

LOCATION Chicopee, Massachusetts

Current Fire Department Training Area

DEPTH	SAMPLES	SAMPLE NO	BLOWS ON SAMPLER				*	SOIL OR ROCK CLASSIFICATION	Diagram
			0-6	6-12	12-18	18-N			
0							Augered to 20.0' No Sampling See Log CF-1 for soil descriptions	<p>6" dia. Guard Pipe w/Locking Cap -2.5'</p> <p>Bentonite/Cement Grout</p> <p>Bentonite Seal -2.5'</p> <p>2" dia. Solid PVC Riser Pipe -3.5'</p> <p>40 Sand -5'</p> <p>2" dia. PVC Well Screen, 0.02" Slot Size</p>	
1									
2									
3									
4									
5									
6									
7									
8									
9									
10									
11									
12									
13									
14									
15									
16									
17									
18									
20							Boring Terminated @ 20.0'	<p>3-3 1/2" dia. Steel Guard Post installed around well.</p> <p>On 1-23-87, water at 7.3' below top of guard pipe.</p>	
21									
22									
23									
24									
25									
26									
27									
28									
29									
30									

*Photovac Reading in ppm above background

N = No blows to drive _____" spoon _____" with _____lb. pin wt. falling _____" per blow. CLASSIFICATION Visual by Drille

C = No blows to drive _____" casing _____" with _____lb. weight falling _____" per blow.

METHOD OF INVESTIGATION 3 1/2" & 6 1/2" I.D. Hollow Stem Augers

DATE

STARTED 11-17-86

FINISHED 11-18-86

SHEET 1 OF 3



SUBSURFACE LOG

HOLE NO. CF-2

SURF. ELEV. _____

C. W. DEPTH See Notes

PROJECT Westover Air Force Base

LOCATION Chicopee, Massachusetts

Current Fire Department Training Area

DEPTH	SAMPLES	SAMPLE NO.	BLOWS ON SAMPLER					*	SOIL OR ROCK CLASSIFICATION	6" dia. Guard Pipe w/ Locking Cap	-3"
			0	1	2	3	4				
0		1	2	4	8	10		Black fine SAND & GRAVEL 1.0'			
			3				0.9	meth. chlor. = 0 Brown fine SAND, little fine gravel (Damp)	Bentonite/Cement Grout	X	
5		2	3	12	13	24		Brown coarse SAND (Moist-Firm)		X	
			15				0			X	
10		3	11	11	12	23		Grey coarse-fine SAND, Some fine Gravel (Wet-Firm)	2" dia. Solid PVC Riser Pipe	X	
			12				1.3	meth. chlor. = 0		X	
15		4	1	2	1	3		Grey fine SAND (Wet-Loose)		X	
			2				1.4			X	
20		5	1	1	1	2		similar		X	
			1				0.3	meth. chlor. = 0		X	
								22.0' 11-17-86 11-18-86		X	
								On 11-18-86, a.m., water at 6.0', casing at 20.0', hole open to 22.0',		X	
25		6	1	2	2	4		Grey fine SAND & fine GRAVEL (Wet-Loose)		X	
			4				0.3			X	
30		7	1	1	1	2		Brown coarse SAND (wet-Loose)		X	
			1				0.3	meth. chlor. < 100		X	
35		8	1	1	3	4		similar		X	
			4				0.4			X	
40										X	

*Photovac Reading in ppm above background

N = No blows to drive 2" spoon 12" with 40 lb. pin wt. falling 30" per blow.

C = No blows to drive casing with lb. weight falling " per blow.

METHOD OF INVESTIGATION: 6" dia. Flush Joint Casing

CLASSIFICATION: sual by Driller

DATE
 STARTED 11-18-86
 FINISHED 11-19-86
 SHEET 2 OF 3



SUBSURFACE LOG

HOLE NO. CF-2 cont'd
 SURF. ELEV. _____
 C. W. DEPTH _____

PROJECT Westover Air Force Base
 Current Fire Department Training Area

LOCATION Chicopee, Massachusetts

DEPTH	SAMPLE NO	BLOWS ON SAMPLER					BLOW ON CASING C	SOIL OR ROCK CLASSIFICATION	NOTES
		0-6	6-12	12-18	18-24	N			
40	9	2	2	2	4		Brown/Grey fine SAND & fine GRAVEL (Wet-Loose) meth. chlor. 100-300 (rig exhaust)	Bentonite/Cement Grout	
		3				0.6			
45	10	2	2	5	7		No Recovery - made two attempts		
		7				0.1			
50	11	5	8	7	15		similar meth. chlor. < 100	2" dia. Solid PVC Riser Pipe	
		8				0			
55	12	8	11	12	23		Brown/Grey fine SAND, trace silt (Wet-Firm)		
		12							
60	13	17	19	18	37		similar meth. chlor 100 < ppm		
		22							
65	14	6	7	7	14	360	similar w/little silt (Wet-Firm)		
		10				410			
						550		Washed ahead of casing from 70.0'-75.0'	
						600			
						670		meth. chlor. < 100 ppm Grey fine SAND (Wet-Firm) 77.0' 11-18-86	
70	15	7	6	6	12	2500			
		12				300		On 11-19-86, a.m., water at 6.5', casing at 75.0', hole open to 77.0'	
						400			
						450		40 Sand	
75	16	9	11	10	21	500			
		14						2" dia. PVC Well Screen, 0.02" Slot Size	
80								*Photovac Reading in ppm above background	

N = No blows to drive 2 " spoon 12 " with 140 lb pin wt. falling 30 " per blow. CLASSIFICATION Visual by Driller:
 C = No blows to drive 6 " casing 12 " with 300 lb. weight falling 18 " per blow.
 METHOD OF INVESTIGATION 6" dia. Flush Joint Casing

DATE

STARTED 11-18-86

FINISHED 11-20-86

SHEET 3 OF 3



SUBSURFACE LOG

HOLE NO. CF-2 cont'd

SURF. ELEV. _____

G.W. DEPTH _____

PROJECT Westover Air Force Base

LOCATION Chicopee, Massachusetts

Current Fire Department Training Area

DEPTH	SAMPLE NO	BLOWS ON SAMPLER					*	SOIL OR ROCK CLASSIFICATION	NOTES
		0	6	12	18	N			
80	17	8	10	20	30		Grey fine SAND, Some Silt, little clay (Wet-Compact) Washed ahead of casing from 80.0'-85.0' meth. chlor. <100 ppm	<p>2" dia. PVC Well Screen, 0.02" slot size 4φ Sand 89'</p>	
	25								
85	18	16	11	14	25		Grey Silty CLAY w/varved zones (Wet-Hard)		
	12								
90	19	13	14	12	26		Grey varved SILT & CLAY (Wet-Hard) meth. chlor. <100 ppm	<p>Boring Terminated @ 92.0'</p> <p>At completion, water at 6.4', casing at 85.0'.</p> <p>Installed monitoring well on 11-20-86. On 12-16-86, pumped well-rate 9 gpm for 10 min. then pumped 2.5 gpm for 10 min. On 1-23-87, water at 8.4' below top of guard pipe.</p>	
	10								
95									

*Photovac Reading in ppm above background

N = No blows to drive 2 " spoon 12 " with 140 lb. pin wt. falling 30 "per blow. CLASSIFICATION Visual by Driller

C = No blows to drive _____ " casing _____ " with _____ lb. weight falling _____ "per blow.

METHOD OF INVESTIGATION 6" dia. Flush Joint Casing

DATE
 STARTED 11-21-86
 FINISHED 11-21-86
 SHEET 1 OF 1



SUBSURFACE LOG
 HOLE NO. CF-2A
 SURF. ELEV. _____
 C. W. DEPTH N/A

PROJECT Westover Air Force Base LOCATION Clicopee, Massachusetts
Current Fire Department Training Area

DEPTH	SAMPLES	SAMPLE NO.	BLOWS ON SAMPLER				*	SOIL OR ROCK CLASSIFICATION	Diagram
			0-6	6-12	12-18	18-24			
0							Augered to 15.0' No Sampling See Log CF-2 for soil descriptions		
1									
2									
3									
4									
5									
6									
7									
8									
9									
10									
11									
12									
13									
14									
15							Boring Terminated @ 15.0'	On 12-16-86, pumped well-rate 6 gpm for approx. 3/4 hour. On 1-23-87, water at 7.7' below top of guard pipe	
16									
17									
18									
19									
20									
21									
22									
23									
24									

*Photovac Reading in ppm above background

N = No blows to drive _____ " spoon _____ " with _____ lb. pin wt. falling _____ " per blow. CLASSIFICATION Visual by Driller
 C = No blows to drive _____ " casing _____ " with _____ lb. weight falling _____ " per blow.
 METHOD OF INVESTIGATION 6 1/4" I.D. Hollow Stem Augers

DATE

STARTED 11-17-86

FINISHED 11-18-86

SHEET 1 OF 1



SUBSURFACE LOG

HOLE NO. CE-3

SURF. ELEV. _____

G. W. DEPTH See Notes

PROJECT Westover Air Force Base

LOCATION Chicopee, Massachusetts

Current Fire Department Training Area

DEPTH	SAMPLES	BLOWS ON SAMPLER					*	SOIL OR ROCK CLASSIFICATION	Diagram
		0-6	6-12	12-18	18-N	N			
0							TOPSOIL 0.3'		
	1	1	1	3	4		Brown medium-fine SAND, little silt (Damp-Loose)		
	2	3	3	4	7		Brown coarse-fine SAND, little silt (Damp-Loose)		
5	3	5	7	7	14		similar w/trace silt (Wet-Firm)		
						4.8			
10	4	4	5	7	12		Brown coarse-fine SAND, little medium-fine gravel, trace silt (Saturated-Firm)		
						2.8	meth. chlor. <100 ppm		
15	5	1	1	2	3		Brown medium-fine SAND, trace silt (saturated-Loose)		
							meth. chlor. <100 ppm		
20	6	1	1	2	3		No Recovery		
						2.4			
							Boring Terminated @ 22.0'		
25									
30									
35									
40									

*Photovac Reading in ppm above background

N = No blows to drive 2" spoon 12" with 140 lb. pin wt. falling 30" per blow. CLASSIFICATION Visual by Dri

C = No blows to drive casing with lb weight falling " per blow.

METHOD OF INVESTIGATION 6 1/4" I.D. Hollow Stem Augers

DATE

STARTED 11-18-86

FINISHED 11-18-86

SHEET 1 Of 1



SUBSURFACE LOG

HOLE NO. CF-4

SURF. ELEV. _____

C. W. DEPTH See Notes

PROJECT Westover Air Force Base

LOCATION Chicopee, Massachusetts

Current Fire Department Training Area

DEPTH	SAMPLE NO	BLOWS ON SAMPLER					*	SOIL OR ROCK CLASSIFICATION	Diagram
		0-6	6-12	12-18	18-24	N			
0	1	1	2	3	5	1.5	TOPSOIL 0.4' Brown medium-fine SAND, little silt (Damp-Loose)		
		4							
5	2	5	6	7	13	1.3	Brown coarse-fine SAND, little fine gravel, trace silt (Saturated-Firm) After sampling #2, water at 4.5', augers at 5.0'.		
		7							
10	3	2	3	3	6	0.6	Brown fine SAND, little silt (Saturated-Firm)		
		3							
15	4	2	5	5	10	0.4	Brown coarse-fine SAND, little medium-fine gravel, trace silt (Saturated-Firm)		
		6							
20	5	1	1	1	2		No Recovery		
		0							
	6	1	0				similar		
25							Boring Terminated @ 23.0'		
30									
35									
40									

*Photovac Reading in ppm above background

N = No blows to drive 2" spoon 12" with 140 lb pin wt. falling 30" per blow. CLASSIFICATION Visual by Drill

C = No blows to drive " casing " with lb. weight falling " per blow.

METHOD OF INVESTIGATION 6 1/4" I.D. Hollow Stem Augers

APPENDIX B - 1b

**Well Installation Logs
Site FT-08**

Source: UNC Geotech, 1991.

WESTOVER AIR FORCE BASE

HOLE NO.: CF-6/6A

TOTAL DEPTH: 90 FT

NO. OF COMPLETIONS: 2

DEPTH (FT)	BLOWS / 6"	SAMPLE INTERVAL	WELL CONSTRUCTION	GRAPHIC LOG	DESCRIPTION		
0					SILT, CLAYEY, VERY DARK BROWN (7.5 YR N2/2), MOIST, LOOSE.		
5	5				SAND, COARSE-GRAINED, BROWNISH GRAY (10 YR 6/2), LOOSE, WET, MINOR PEBBLES.		
10	8						
15	5						
20	7						
25	4						
30	3						
35	2						
40	2						
45	1						
50	5						
55	4						
60	1						LOCAL LENSES OF FINE - TO MEDIUM-GRAINED SAND BETWEEN 50 AND 65 FEET.
65	1						
70	1						
75	3						SAND, FINE-GRAINED, GRAY (10 YR 5/1), SATURATED.
80	2						
85	10				SAND, MEDIUM-GRAINED, GRAYISH BROWN (10 YR 5/2), LOOSE, SATURATED.		
90	7				VARVES OF ALTERNATING CLAY, DARK GRAY (10 YR 3/4), AND SILT, CLAYEY, PALE BROWN (10 YR 6/3), SOFT TO MODERATELY STIFF, SATURATED.		

WESTOVER AIR FORCE BASE
 HOLE NO.: CF-7
 TOTAL DEPTH: 95 FT
 NO. OF COMPLETIONS: 1

DEPTH (FT)	BLOWS/6"	SAMPLE INTERVAL	WELL CONSTRUCTION	GRAPHIC LOG	DESCRIPTION
0					SAND, SILTY, VERY DARK GRAYISH BROWN (10 YR 3/2) LOOSE, MOIST.
5	5 10 15 16				SAND, COARSE-GRAINED, YELLOWISH BROWN (10 YR 5/6) SATURATED BELOW 5.5 FEET.
10	9 20 18 14				SAND, VERY COARSE-GRAINED, LIGHT YELLOWISH BROWN (10 YR 6/4), NUMEROUS PEBBLES.
15	6 10 10 7				
20	11 12 9 7				SAND, FINE-GRAINED, LIGHT YELLOWISH BROWN (10 YR 5/4) LOOSE, NO PEBBLES.
25	5 10 5 7				
30	10 14 20 17				GRADES TO SAND, COARSE-GRAINED AT 30 FEET.
35	10 12 18 22				GRADES TO SAND, FINE-GRAINED, (10 YR 5/3) NO PEBBLES.
40	14 14 20 22				
45	11 12 11 12				
50					SAND, UNDIFFERENTIATED, GLACIAL OUTWASH, NOT SAMPLED BECAUSE SAND RUNS.
55					
60					
65					
70					
75					
80					
85					CLAY, SILTY, GRAY (10 YR 5/1), LACUSTRINE DEPOSITS.
90					
95					

APPENDIX B - 1c

**Well Installation Log
Site FT-08**

Source: O'Brien and Gere, 1994.

O'BRIEN & GERE ENGINEERS, INC.

SOIL BORING LOG

LOG NUMBER: OBG-CF8

SHEET 1 OF 1

CLIENT: United States Air Force

GROUNDWATER LEVELS

FILE No.: 1549.009

DATE DEPTH ELEV.

DRILLING METHOD: Hollow Stem Auger

PROJECT LOCATION: Westover, A.F.B.
Chicopee, Massachusetts

SAMPLER TYPE: Split spoon

HAMMER: 140lb FALL: 30"

O'BRIEN & GERE GEOLOGIST: FJ Ferreira
DRILLING CO.: A&W Environmental Drilling

BORING LOCATION: FT-08 CFTA

LEGEND: Grout/Bent.

Screen

FOREMAN: J. Halaburda

GROUND ELEVATION:

Sand Packing

Riser

DATES: STARTED: 6/16/93 ENDED: 6/16/93

Natural Mater.

No.	DEPTH	SAMPLE		"N" VALUE	SAMPLE DESCRIPTION	STRATUM CHANGE DEPTH	EQUIPMENT INSTALLED	FIELD TESTING			
		DRIVER BLOWS	PENETRATION RECOVERY (inches)					SAL. 0/00	H/S	HNu (ppm)	S*
	0'-5'		No Sample		(Fill)						
1	5'-7'	6-6-7-7	24/12	13	Med. Densc. Brown/Tan, Moist, F-C SAND, some v-f gravel, tr. silt						0.0
2	10'-12'	3-2-6-4	24/14	8	(Fill) Loose, Brown/Gray, Wet, F-M SAND, some v-f gravel, tr. v-f pebbles						0.0
3	15'-17'	2-1-2-1	24/24	3	Loose, Gray/Tan, Wet, F-M SAND, some v-f gravel	10'					0.0
4	20'-22'	W-W-1-1	24/3	1	(Glacial Outwash Deposit) Loose, Gray, Wet, SILTY SAND, tr. f-m sand (Glacial Lacustrine Deposit)	20'					0.0
					BOTTOM OF EXPLORATION @ 22.0'						

Note: WELL CONSTRUCTION DETAILS

- 2" ID schedule 40 PVC well set @ 20'
- 15' of 10 slot screen set from 20'-5'
- 5' of solid riser positioned from 5'-(-)2'
- Washed silica sand positioned from 20'-4'
- Bentonite seal from 4'-2'
- Grout set from 2'-0'
- Measurements referenced from grade.
- Well encapsulated in 2' locking steel casing.

Field testing/HNu column presents soil screening results. HNu calibrated to a benzene equivalent.

APPENDIX B - 2

**Summary of Soil and Groundwater
Analytical Data
Site FT-08**

Source: O'Brien and Gere, 1994.

WAFB Site FT-08: Ground Water Investigation
Validated Results for Total Metals and Total Dissolved Solids Analyses

SITE LOCATION ANALYTE	CF-7	CF-8	CF-6	CF-5	CF-3	CF-2	CF-4	DUP (CF-7)	EQBLK (6/25/93)
Aluminum	1.8	20.6	22.7	7.9	0.28	0.16	34.4	2.1	0.10 U
Antimony	0.060 U	0.060 U	0.060 U	0.060 U	0.060 U	0.060 U	0.060 U	0.060 U	0.060 U
Arsenic	0.10 U	0.10 U	0.10 U	0.10 U	0.10 U	0.10 U	0.10 U	0.10 U	0.10 U
Barium	0.024	0.077 J	0.17	0.064	0.061	0.013	0.17	0.025	0.010 U
Beryllium	0.0020 U	0.0010	0.00083 J	0.00040 J	0.0020 U	0.0020 U	0.0010 J	0.0020 U	0.0020 U
Cadmium	0.0050 U	0.0050 U	0.0050 U	0.0050 U	0.0050 U	0.0050 U	0.0050 U	0.0050 U	0.0050 U
Calcium	2.2 J	5.4 J	5.9 J	5.8 J	6.4 J	5.3 J	10.0 J	2.1 J	0.026 J
Chromium	0.010 U	0.017	0.024	0.010 U	0.010 U	0.010 U	0.029	0.010 U	0.010 U
Cobalt	0.010 U	0.0057 J	0.011	0.010 U	0.0051 J	0.010 U	0.010	0.010 U	0.010 U
Copper	0.015 J	0.040	0.027	0.020 U	0.012 J	0.0066 J	0.070	0.020 U	0.020 U
Iron	10.8	14.9	44.6	27.2	16.9	6.4	29.8	12.1	0.050 U
Lead	0.0017 J	0.01	0.013	0.0039 J	0.0053 J	0.0013 J	0.025	0.0021 J	0.0050 U
Magnesium	0.94	2.9	7.2	2.6	0.64	0.74	8.3	0.95	0.20 U
Manganese	0.043	0.32	0.42	0.15	0.13	0.15	0.19	0.046	0.010 U
Molybdenum	0.020 U	0.020 U	0.020 U	0.020 U	0.020 U	0.020 U	0.0051 J	0.020 U	0.020 U
Nickel	0.040 U	0.013 J	0.013 J	0.040 U	0.040 U	0.0056 J	0.021 J	0.040 U	0.040 U
Potassium	1.0	2.2	6.5	2.3	2.8	1.5	6.7	1.1	1.0 U
Selenium	0.20 U	0.20 U	0.20 U	0.20 U	0.20 U	0.20 U	0.20 U	0.20 U	0.20 U
Silver	0.010 U	0.010 U	0.010 U	0.010 U	0.010 U	0.010 U	0.010 U	0.010 U	0.010 U
Sodium	1.4	2.0	4.6	2.4	2.0	3.5	1.6	1.4	0.17 J
Thallium	0.40 U	0.40 U	0.40 U	0.40 U	0.40 U	0.40 U	0.40 U	0.40 U	0.40 U
Vanadium	0.0040 JB	0.033	0.052	0.013 JB	0.0098 JB	0.010 U	0.062	0.010 U	0.010 U
Zinc	0.017 J	0.037	0.049	0.019 J	0.023	0.032	0.063	0.0098 J	0.0038 J
Total Dissolved Solids	55.0 J	52.0	53.0	84.0	115	183	1020	26.0 J	43.0

UNITS: MG/L

TABLE C2

WAFB Site FT-08: Ground Water Investigation
Validated Results for Dissolved Metals

SITE/LOCATION ANALYTE	GF-7	GF-8	GF-6	GF-5	GF-3	GF-2	GF-4	DUP (GF-7)
Aluminum	0.066 J	0.045 J	0.10 U	0.058 J	0.056 J	0.10 U	0.084 J	0.060 J
Antimony	0.060 U	0.060 U	0.060 U	0.060 U	0.060 U	0.060 U	0.060 U	0.060 U
Arsenic	0.10 U	0.10 U	0.10 U	0.10 U	0.10 U	0.10 U	0.10 U	0.10 U
Barium	0.014	0.020	0.012	0.031	0.072	0.012	0.0081 J	0.010
Beryllium	0.0020 U	0.0020 U	0.0020 U	0.0020 U	0.0020 U	0.0020 U	0.0020 U	0.0020 U
Cadmium	0.0050 U	0.0050 U	0.0050 U	0.0050 U	0.0050 U	0.0050 U	0.0050 U	0.0050 U
Calcium	2.0	4.1 J	4.1	5.4	6.7	4.7	2.3	2.0
Chromium	0.010 U	0.010 U	0.010 U	0.010 U	0.010 U	0.010 U	0.010 U	0.010 U
Cobalt	0.010 U	0.010 U	0.010 U	0.010 U	0.010 U	0.010 U	0.010 U	0.010 U
Copper	0.020 U	0.0076 J	0.0064 J	0.020 U	0.020 U	0.0064 J	0.0099 J	0.020 U
Iron	0.058	1.3	2.5	10.9	16.9	5.7	0.017 J	0.052
Lead	0.0022 J	0.0050 U	0.0050 U	0.0050 U	0.0027 J	0.0050 U	0.0050 U	0.0050 U
Magnesium	0.26	0.70	0.62	1.0	0.73	0.78	0.56	0.27
Manganese	0.023	0.22	0.19	0.12	0.14	0.16	0.0021	0.023
Molybdenum	0.020 U	0.020 U	0.020 U	0.020 U	0.020 U	0.020 U	0.020 U	0.020 U
Nickel	0.040 U	0.040 U	0.040 U	0.040 U	0.040 U	0.040 U	0.040 U	0.040 U
Potassium	0.46 J	0.63 J	0.72 J	0.98 J	2.5	1.4	0.89 J	0.51 J
Selenium	0.20 U	0.20 U	0.20 U	0.20 U	0.20 U	0.20 U	0.20 U	0.20 U
Silver	0.010 U	0.010 U	0.010 U	0.010 U	0.010 U	0.010 U	0.010 U	0.010 U
Sodium	1.2	1.7	3.6	2.2	2.2	3.9	0.94 J	1.3
Thallium	0.40 U	0.40 U	0.40 U	0.40 U	0.40 U	0.40 U	0.40 U	0.40 U
Vanadium	0.010 U	0.010 U	0.010 U	0.010 U	0.0061 J	0.010 U	0.010 U	0.010 U
Zinc	0.011 J	0.012 J	0.0099 J	0.010 J	0.0043 J	0.014 J	0.011 J	0.012 J

UNITS: MG/L

WAFB Site FT-08: Soil Boring Investigation
Validated Results for Total Metals

SITE LOCATION DEPTH (FEET) ANALYTE	1+0-600R (0-2)	2+0-600R (0-2)	3+0-600R (0-2)	4+0-600R (0-2)	0+0-400R (0-2)	1+0-400R (0-2)	2+0-400R (0-2)	3+0-400R (0-2)	4+0-400R (0-2)
Aluminum	10700	4790	8490	7320	8840	6620	8060	6400	5780
Antimony	7.2 U	6.4 U	7.4 U	7.4 U	9.1 UJ	9.1 U	9.3 U	6.7 U	6.6 U
Arsenic	7.3 J	10.7 U	3.6 J	12.4 U	6.3 J	3.3 J	9.2 J	6.1 J	4.4 J
Barium	16.3	16.0	12.4	13.6	16.0	10.3	14.0	22.8	23.4
Beryllium	0.24	0.18 J	0.25	0.14 J	0.21 J	0.15 J	0.30	0.27	0.23
Cadmium	0.60 U	0.53 U	0.61 U	0.62 U	0.76 U	0.76 U	0.78 U	0.56 U	0.55 U
Calcium	129	256	126	184	295	139	275	735	1560
Chromium	10.0	5.8	6.5	6.6	8.3	6.8	7.9	7.0	7.1
Cobalt	1.8 JB	1.6 JB	0.91 JB	0.97 JB	1.4 JB	0.99 JB	1.4 JB	1.9 JB	2.1 JB
Copper	3.1	3.4	1.3	2.6	3.7	3.8	7.0	4.8	4.7
Iron	6320	5130	4960	4020	4840	2780	3450	7020	6090
Lead	4.3 J	2.9 J	3.9 J	11.9 J	9.1 J	10.0 J	11.6 J	6.0 J	9.6 J
Magnesium	1500	1200	898	773	1270	766	877	1370	1420
Manganese	36.0	34.4	23.0	23.6	34.1	19.6	25.2	44.9	49.1
Molybdenum	0.66 J	2.1 U	2.5 U	2.5 U	0.94 J	3.0 U	3.1 U	0.66 J	0.77 J
Nickel	4.5 J	3.5 J	2.5 J	3.0 J	4.3 J	3.2 J	4.3 J	4.8	4.4
Potassium	530	680	306	336	475	311	402	489	704
Selenium	23.9 U	21.4 U	24.5 U	24.8 U	30.4 U	30.3 U	31.1 U	22.3 U	5.3 J
Silver	1.2 U	1.1 U	1.2 U	1.2 U	1.5 U	1.5 U	1.6 U	1.1 U	1.1 U
Sodium	81.5 JB	74.0 JB	78.8 JB	89.8 JB	113 JB	99.1 JB	93.0 JB	84.1 JB	87.8 JB
Thallium	47.7 U	42.8 U	49.0 U	49.6 U	60.9 U	60.7 U	62.1 U	44.7 U	44.0 U
Vanadium	21.5	12.1	14.6	12.5	18.0	11.1	12.3	16.8	13.3
Zinc	16.1	10.7	9.8	10.4	16.3	9.9	11.5	12.0	14.0
Percent Solids **	83.8	93.5	81.6	80.6	65.7	65.9	64.4	89.5	91.0

UNIT: MG/KG DRY WEIGHT

IG/L

** PERCENT

NA: Analysis not required

08694

TABLE C3 (PAGE 2 OF 2)

WAFB Site FT-08: Soil Boring Investigation
Validated Results for Total Metals

SITE LOCATION DEPTH (FEET) ANALYTE	0+0-500R (0-2)	1+0-500R (0-2)	2+0-500R (0-2)	DUP (0-2) (1+0-500R)	EQBLK* (6/23/93)
Aluminum	5870	4860	7030	4810	0.10 U
Antimony	8.2 U	7.0 U	7.2 U	6.5 U	0.060 U
Arsenic	5.5 J	4.4 J	3.1 J	4.2 J	0.10 U
Barium	12.0	15.9 J	15.8	35.0 J	0.010 U
Cadmium	0.19 J	0.21	0.22 J	0.18 J	0.0020 U
Calcium	0.69 U	0.58 U	0.60 U	0.54 U	0.0050 U
Chromium	239	241	143	392	0.20 U
Cobalt	5.9	6.6	7.3	6.7	0.010 U
Copper	1.2 JB	1.7 JB	1.8 JB	1.6 JB	0.0051 J
Iron	4.0	4.9	3.6	4.4	0.020 U
Lead	4510	5420	6220	4850	0.050 U
Magnesium	4.9 J	7.1 J	3.0 J	5.8 J	0.0012 J
Manganese	971	1210	1300	1280	0.20 U
Molybdenum	28.3	35.7	35.0	38.1	0.010 U
Nickel	2.7 U	0.58 J	2.4 U	2.2 U	0.020 U
Potassium	2.9 J	3.8 J	3.5 J	4.5	0.040 U
Selenium	474	668	564	752	1.0 U
Silver	27.5 U	23.2 U	24.1 U	21.6 U	0.20 U
Sodium	1.4 U	1.2 U	1.2 U	1.1 U	0.010 U
Thallium	93.4 JB	60.6 JB	83.3 JB	80.6 JB	0.19 J
Zinc	54.9 U	46.4 U	48.1 U	43.3 U	0.40 U
	14.4	14.2	15.8	12.4	0.010 U
	10.2	14.2	12.2	12.0	0.020 U
Percent Solids **	72.8	86.2	83.1	92.4	NA

UNITS: MG/KG DRY WEIGHT

* MG/L

** PERCENT

NA: Analysis not required

TABLE C4

WAFB Site FT-08: Ground Water Investigation
Validated Results for Volatile Analyses

SITE LOCATION COMPOUND	CF-7	CF-8	CF-6	CF-5	CF-3	CF-2	CF-4	DUP (CF-7)	EOBLK (6/25/93)	TBLK (6/26/93)	TBLK (6/24/93)
Chloromethane	10 U	10 U	10 U	10 U	500 U	10 U	10 U	10 U	10 U	10 U	10 U
Bromomethane	10 U	10 U	10 U	10 U	500 U	10 U	10 U	10 U	10 U	10 U	10 U
Vinyl Chloride	10 U	10 U	10 U	10 U	500 U	10 U	10 U	10 U	10 U	10 U	10 U
Chloroethane	10 U	10 U	10 U	10 U	500 U	10 U	10 U	10 U	10 U	10 U	10 U
Methylene Chloride	5.0 U	5.0 U	5.0 U	5.0 U	60 JB	2.4 JB	5.0 U	2.3 JB	2.2 J	2.7 J	1.0 J
Acetone	10 U	10 U	10 U	10 U	250 UJ	10 UJ	10 U	10 U	10 U	10 U	10 U
Carbon Disulfide	5.0 U	5.0 U	5.0 U	5.0 U	250 U	5.0 U	5.0 U	5.0 U	5.0 U	5.0 U	5.0 U
1,1-Dichloroethene	5.0 U	5.0 U	5.0 U	5.0 U	250 U	5.0 U	5.0 U	5.0 U	5.0 U	5.0 U	5.0 U
1,1-Dichloroethane	5.0 U	5.0 U	5.0 U	5.0 U	250 U	5.0 U	5.0 U	5.0 U	5.0 U	5.0 U	5.0 U
1,2-Dichloroethene (total)	5.0 U	5.0 U	5.0 U	7.2	870	5.0 U	5.0 U	5.0 U	5.0 U	5.0 U	5.0 U
Chloroform	5.0 U	5.0 U	5.0 U	5.0 U	250 U	5.0 U	5.0 U	5.0 U	5.0 U	5.0 U	5.0 U
1,2-Dichloroethane	5.0 U	5.0 U	5.0 U	5.0 U	250 U	5.0 U	5.0 U	5.0 U	5.0 U	5.0 U	5.0 U
2-Butanone	10 U	10 U	10 U	10 U	500 U	10 U	10 U	10 U	10 U	10 U	10 U
1,1,1-Trichloroethane	5.0 U	5.0 U	5.0 U	5.0 U	250 U	5.0 U	5.0 U	5.0 U	5.0 U	5.0 U	5.0 U
Carbon Tetrachloride	5.0 U	5.0 U	5.0 U	5.0 U	250 U	5.0 U	5.0 U	5.0 U	5.0 U	5.0 U	5.0 U
Vinyl acetate	10 U	10 U	10 U	10 U	500 U	10 U	10 U	10 U	10 U	10 U	10 U
Bromodichloromethane	5.0 U	5.0 U	5.0 U	5.0 U	250 U	5.0 U	5.0 U	5.0 U	5.0 U	5.0 U	5.0 U
1,2-Dichloropropane	5.0 U	5.0 U	5.0 U	5.0 U	250 U	5.0 U	5.0 U	5.0 U	5.0 U	5.0 U	5.0 U
cis-1,3-Dichloropropene	5.0 U	5.0 U	5.0 U	5.0 U	250 U	5.0 U	5.0 U	5.0 U	5.0 U	5.0 U	5.0 U
Trichloroethene	5.0 U	5.0 U	1.5 J	5.0 U	5400	5.0 U	5.0 U	5.0 U	5.0 U	5.0 U	5.0 U
Dibromochloromethane	5.0 U	5.0 U	5.0 U	5.0 U	250 U	5.0 U	5.0 U	5.0 U	5.0 U	5.0 U	5.0 U
1,1,2-Trichloroethane	5.0 U	5.0 U	5.0 U	5.0 U	250 U	5.0 U	5.0 U	5.0 U	5.0 U	5.0 U	5.0 U
Benzene	5.0 U	5.0 U	1.4 J	4.9 J	200 J	5.0 U	5.0 U	5.0 U	5.0 U	5.0 U	5.0 U
trans-1,3-Dichloropropene	5.0 U	5.0 U	5.0 U	5.0 U	250 U	5.0 U	5.0 U	5.0 U	5.0 U	5.0 U	5.0 U
2-chloroethyl vinyl ether	10 UJ	10 UJ	10 UJ	10 UJ	500 UJ	10 UJ	10 UJ	10 UJ	10 UJ	10 UJ	10 UJ
Bromoform	5.0 U	5.0 U	5.0 U	5.0 U	250 U	5.0 U	5.0 U	5.0 U	5.0 U	5.0 U	5.0 U
4-Methyl-2-Pentanone	10 U	10 U	10 U	10 U	500 U	10 U	10 U	10 U	10 U	10 U	10 U
2-Hexanone	10 U	10 U	10 U	10 U	500 U	10 U	10 U	10 U	10 U	10 U	10 U
Tetrachloroethene	5.0 U	5.0 U	5.0 U	5.0 U	250 U	5.0 U	5.0 U	5.0 U	5.0 U	5.0 U	5.0 U
1,1,2,2-Tetrachloroethane	5.0 U	5.0 U	5.0 U	5.0 U	250 U	5.0 U	5.0 U	5.0 U	5.0 U	5.0 U	5.0 U
Toluene	5.0 U	5.0 U	5.0 U	5.0 U	2000	5.0 U	5.0 U	5.0 U	5.0 U	5.0 U	5.0 U
Chlorobenzene	5.0 U	5.0 U	5.0 U	5.0 U	250 U	5.0 U	5.0 U	5.0 U	5.0 U	5.0 U	5.0 U
Ethylbenzene	5.0 U	5.0 U	5.0 U	1.1 J	440	5.0 U	5.0 U	5.0 U	5.0 U	5.0 U	5.0 U
Styrene	5.0 U	5.0 U	5.0 U	5.0 U	250 U	5.0 U	5.0 U	5.0 U	5.0 U	5.0 U	5.0 U
Xylene (total)	5.0 U	5.0 U	5.0 U	2.4 J	2300	5.0 U	5.0 U	5.0 U	5.0 U	5.0 U	5.0 U

UNITS: UG/L

WAFB Site FT-08: Soil Boring Investigation
Validated Results for Volatile Analyses

SITE LOCATION DEPTH (FEET) COMPOUND	1+0-600R (0-2)	2+0-600R (0-2)	3+0-600R (0-2)	4+0-600R (0-2)	0+0-400R (0-2)	1+0-400R (0-2)	2+0-400R (0-2)	3+0-400R (0-2)	4+0-400R (0-2)
Chloromethane	12 U	11 U	12 U	12 U	15 U	15 U	16 UJ	11 UJ	11 U
Bromomethane	12 U	11 U	12 U	12 U	15 U	15 U	16 UJ	11 UJ	11 U
Vinyl Chloride	12 U	11 U	12 U	12 U	15 U	15 U	16 UJ	11 UJ	11 U
Chloroethane	12 U	11 U	12 U	12 U	15 U	15 U	16 UJ	11 UJ	11 U
Methylene Chloride	6.0 U	4.2 JB	6.1 U	4.8 JB	7.6 U	7.6 U	7.8 UJ	3.8 JB	5.5 U
Acetone	12 U	11 U	12 U	12 U	15 UJ	15 U	16 UJ	11 UJ	11 U
Carbon Disulfide	6.0 U	5.3 U	6.1 U	6.2 U	7.6 U	7.6 U	7.6 UJ	5.6 UJ	5.6 U
1,1-Dichloroethene	6.0 U	5.3 U	6.1 U	6.2 U	7.6 U	7.6 U	7.6 UJ	5.6 UJ	5.6 U
1,1-Dichloroethane	6.0 U	5.3 U	6.1 U	6.2 U	7.6 U	7.6 U	7.6 UJ	5.6 UJ	5.6 U
1,2-Dichloroethene (total)	6.0 U	5.3 U	6.1 U	6.2 U	7.6 U	7.6 U	7.6 UJ	5.6 UJ	5.6 U
Chloroform	6.0 U	5.3 U	6.1 U	6.2 U	7.6 U	7.6 U	7.6 UJ	5.6 UJ	5.6 U
1,2-Dichloroethane	6.0 U	5.3 U	6.1 U	6.2 U	7.6 U	7.6 U	7.6 UJ	5.6 UJ	5.6 U
2-Butanone	12 U	11 U	12 U	12 U	15 U	15 U	16 UJ	11 UJ	11 U
1,1,1-Trichloroethane	6.0 U	5.3 U	6.1 U	6.2 U	7.6 U	7.6 U	7.6 UJ	5.6 UJ	5.6 U
Carbon Tetrachloride	6.0 U	5.3 U	6.1 U	6.2 U	7.6 U	7.6 U	7.6 UJ	5.6 UJ	5.6 U
Vinyl acetate	12 U	11 U	12 U	12 U	15 U	15 U	16 UJ	11 UJ	11 U
Bromodichloromethane	6.0 U	5.3 U	6.1 U	6.2 U	7.6 U	7.6 U	7.6 UJ	5.6 UJ	5.6 U
1,2-Dichloropropane	6.0 U	5.3 U	6.1 U	6.2 U	7.6 U	7.6 U	7.6 UJ	5.6 UJ	5.6 U
cis-1,3-Dichloropropene	6.0 U	5.3 U	6.1 U	6.2 U	7.6 U	7.6 U	7.6 UJ	5.6 UJ	5.6 U
Trichloroethene	6.0 U	5.3 U	6.1 U	6.2 U	7.6 U	7.6 U	7.6 UJ	5.6 UJ	5.6 U
Dibromochloromethane	6.0 U	5.3 U	6.1 U	6.2 U	7.6 U	7.6 U	7.6 UJ	5.6 UJ	5.6 U
1,1,2-Trichloroethane	6.0 U	5.3 U	6.1 U	6.2 U	7.6 U	7.6 U	7.6 UJ	5.6 UJ	5.6 U
Benzene	6.0 U	5.3 U	6.1 U	6.2 U	7.6 U	7.6 U	7.6 UJ	5.6 UJ	5.6 U
trans-1,3-Dichloropropene	6.0 U	5.3 U	6.1 U	6.2 U	7.6 U	7.6 U	7.6 UJ	5.6 UJ	5.6 U
2-chloroethyl vinyl ether	12 UJ	11 UJ	12 UJ	12 UJ	15 UJ	15 UJ	16 UJ	11 UJ	11 UJ
Bromoform	6.0 U	5.3 U	6.1 U	6.2 U	7.6 U	7.6 U	7.6 UJ	5.6 UJ	5.6 U
4-Methyl-2-Pentanone	12 U	11 U	12 U	12 U	15 U	15 U	16 UJ	11 UJ	11 U
2-Hexanone	12 U	11 U	12 U	12 U	15 U	15 U	16 UJ	11 UJ	11 U
Tetrachloroethene	6.0 U	5.3 U	6.1 U	6.2 U	7.6 U	7.6 U	7.6 UJ	5.6 UJ	5.6 U
1,1,2,2-Tetrachloroethane	6.0 U	5.3 U	6.1 U	6.2 U	7.6 U	7.6 U	7.6 UJ	5.6 UJ	5.6 U
Toluene	6.0 U	5.3 U	6.1 U	6.2 U	7.6 U	7.6 U	7.6 UJ	5.6 UJ	5.6 U
Chlorobenzene	6.0 U	5.3 U	6.1 U	6.2 U	7.6 U	7.6 U	7.6 UJ	5.6 UJ	5.6 U
Ethylbenzene	6.0 U	5.3 U	6.1 U	6.2 U	7.6 U	7.6 U	7.6 UJ	5.6 UJ	5.6 U
Styrene	6.0 U	5.3 U	6.1 U	6.2 U	7.6 U	7.6 U	7.6 UJ	5.6 UJ	5.6 U
Xylene (total)	6.0 U	0.92 J	6.1 U	6.2 U	7.6 U	7.6 U	7.6 UJ	5.6 UJ	5.6 U

UNITS: UG/KG DRY WEIGHT
* UG/L

WAFB Site FT-08: Soil Boring Investigation
Validated Results for Volatile Analyses

SITE LOCATION DEPTH (FEET) COMPOUND	0+0-500R (0-2)	1+0-500R (0-2)	2+0-500R (0-2)	DUP (0-2) (1+0-500R)	EQBLK* (6/23/93)	TBLK* (6/23/93)	TBLK* (6/24/93)
Chloromethane	14 U	12 U	12 U	11 U	10 U	10 U	10 U
Bromomethane	14 U	12 U	12 U	11 U	10 U	10 U	10 U
Vinyl Chloride	14 U	12 U	12 U	11 U	10 U	10 U	10 U
Chloroethane	14 U	12 U	12 U	11 U	10 U	10 U	10 U
Methylene Chloride	6.9 U	5.8 U	6.0 U	5.4 U	5.0 U	4.5 J	0.97 J
Acetone	14 U	12 U	12 U	11 U	10 U	10 U	10 U
Carbon Disulfide	6.9 U	5.8 U	6.0 U	5.4 U	5.0 U	5.0 U	5.0 U
1,1-Dichloroethene	6.9 U	5.8 U	6.0 U	5.4 U	5.0 U	5.0 U	5.0 U
1,1-Dichloroethane	6.9 U	5.8 U	6.0 U	5.4 U	5.0 U	5.0 U	5.0 U
1,2-Dichloroethene (total)	6.9 U	5.8 U	6.0 U	5.4 U	5.0 U	5.0 U	5.0 U
Iodoform	6.9 U	5.8 U	6.0 U	5.4 U	5.0 U	5.0 U	5.0 U
1,2-Dichloroethane	6.9 U	5.8 U	6.0 U	5.4 U	5.0 U	5.0 U	5.0 U
2-Butanone	14 U	12 U	12 U	11 U	10 U	10 U	10 U
1,1,1-Trichloroethane	6.9 U	5.8 U	6.0 U	5.4 U	5.0 U	5.0 U	5.0 U
Carbon Tetrachloride	6.9 U	5.8 U	6.0 U	5.4 U	5.0 U	5.0 U	5.0 U
Vinyl acetate	14 U	12 U	12 U	11 U	10 U	10 U	10 U
Bromodichloromethane	6.9 U	5.8 U	6.0 U	5.4 U	5.0 U	5.0 U	5.0 U
1,2-Dichloropropane	6.9 U	5.8 U	6.0 U	5.4 U	5.0 U	5.0 U	5.0 U
cis-1,3-Dichloropropene	6.9 U	5.8 U	6.0 U	5.4 U	5.0 U	5.0 U	5.0 U
Trichloroethene	1.8 J	0.88 J	6.0 U	4.2 J	5.0 U	5.0 U	5.0 U
Dibromochloromethane	6.9 U	5.8 U	6.0 U	5.4 U	5.0 U	5.0 U	5.0 U
1,1,2-Trichloroethane	6.9 U	5.8 U	6.0 U	5.4 U	5.0 U	5.0 U	5.0 U
Benzene	6.9 U	5.8 U	6.0 U	5.4 U	5.0 U	5.0 U	5.0 U
trans-1,3-Dichloropropene	6.9 U	5.8 U	6.0 U	5.4 U	5.0 U	5.0 U	5.0 U
2-chloroethyl vinyl ether	14 UJ	12 UJ	12 UJ	11 UJ	10 UJ	10 UJ	10 UJ
Bromoform	14 U	5.8 U	6.0 U	5.4 U	5.0 U	5.0 U	5.0 U
4-Methyl-2-Pentanone	6.9 U	12 U	12 U	11 U	10 U	10 U	10 U
Hexanone	6.9 U	12 U	12 U	11 U	10 U	10 U	10 U
Tetrachloroethene	6.9 U	5.8 U	6.0 U	5.4 U	5.0 U	5.0 U	5.0 U
1,1,2,2-Tetrachloroethane	6.9 U	5.8 U	6.0 U	5.4 U	5.0 U	5.0 U	5.0 U
Toluene	6.9 U	5.8 U	6.0 U	1.0 JB	0.21 J	0.24 J	5.0 U
Chlorobenzene	6.9 U	5.8 U	6.0 U	5.4 U	5.0 U	5.0 U	5.0 U
Ethylbenzene	6.9 U	5.8 U	6.0 U	5.4 U	5.0 U	5.0 U	5.0 U
Styrene	6.9 U	5.8 U	6.0 U	5.4 U	5.0 U	5.0 U	5.0 U
Xylene (total)	6.9 U	1.4 J	6.0 U	5.4 U	5.0 U	5.0 U	5.0 U

UNITS: UG/KG DRY WEIGHT
* UG/L

TABLE C6 (PAGE 1 OF 2)

WAFB Site FT-08: Ground Water Investigation
Validated Results for Semi-Volatile Analyses

SITE LOCATION ANALYTE	CF-7	CF-8	CF-6	CF-5	CF-3	CF-2	CF-4	DUP (CF-7)	EQBLK (6/25/93)
Phenol	10 U	10 U	10 U	10 U	10 U	10 U	10 U	10 U	10 U
bis(2-Chloroethyl)ether	10 U	10 U	10 U	10 U	10 U	10 U	10 U	10 U	10 U
2-Chlorophenol	10 U	10 U	10 U	10 U	10 U	10 U	10 U	10 U	10 U
1,3-Dichlorobenzene	10 U	10 U	10 U	10 U	10 U	10 U	10 U	10 U	10 U
1,4-Dichlorobenzene	10 U	10 U	10 U	10 U	10 U	10 U	10 U	10 U	10 U
Benzyl alcohol	10 U	10 U	10 U	10 U	10 U	10 U	10 U	10 U	10 U
2-Dichlorobenzene	10 U	10 U	10 U	10 U	10 U	10 U	10 U	10 U	10 U
2-Methylphenol	10 U	10 U	10 U	10 U	9.7 J	10 U	10 U	10 U	10 U
bis(2-chloroisopropyl)ether	10 U	10 U	10 U	10 U	10 U	10 U	10 U	10 U	10 U
3/4-Methylphenol	10 U	10 U	10 U	10 U	33	10 U	10 U	10 U	10 U
N-Nitroso-di-n-propylamine	10 U	10 U	10 U	10 U	10 U	10 U	10 U	10 U	10 U
Hexachloroethane	10 U	10 U	10 U	10 U	10 U	10 U	10 U	10 U	10 U
Nitrobenzene	10 U	10 U	10 U	10 U	10 U	10 U	10 U	10 U	10 U
Isophorone	10 U	10 U	10 U	10 U	10 U	10 U	10 U	10 U	10 U
2-Nitrophenol	10 U	10 U	10 U	10 U	10 U	10 U	10 U	10 U	10 U
2,4-Dimethylphenol	10 U	10 U	10 U	10 U	10 U	10 U	10 U	10 U	10 U
Benzoic acid	50 U	50 U	50 U	50 U	50 U	50 U	50 U	50 U	50 U
bis(2-Chloroethoxy)methane	10 U	10 U	10 U	10 U	10 U	10 U	10 U	10 U	10 U
2,4-Dichlorophenol	10 U	10 U	10 U	10 U	10 U	10 U	10 U	10 U	10 U
1,2,4-Trichlorobenzene	10 U	10 U	10 U	10 U	10 U	10 U	10 U	10 U	10 U
Naphthalene	10 U	10 U	10 U	10 U	26	10 U	10 U	10 U	10 U
4-Chloroaniline	10 U	10 U	10 U	10 U	10 U	10 U	10 U	10 U	10 U
Hexachlorobutadiene	10 U	10 U	10 U	10 U	10 U	10 U	10 U	10 U	10 U
2-Chloro-3-methylphenol	10 U	10 U	10 U	10 U	10 U	10 U	10 U	10 U	10 U
2-Methylnaphthalene	10 U	10 U	10 U	10 U	8.0 J	10 U	10 U	10 U	10 U
Hexachlorocyclopentadiene	10 U	10 U	10 U	10 U	10 U	10 U	10 U	10 U	10 U
2,4,6-Trichlorophenol	10 U	10 U	10 U	10 U	10 U	10 U	10 U	10 U	10 U
2,4,5-Trichlorophenol	50 U	50 U	50 U	50 U	50 U	50 U	50 U	50 U	50 U
2-Chloronaphthalene	10 U	10 U	10 U	10 U	10 U	10 U	10 U	10 U	10 U
2-Nitroaniline	50 U	50 U	50 U	50 U	50 U	50 U	50 U	50 U	50 U
Dimethylphthalate	10 U	10 U	10 U	10 U	10 U	10 U	10 U	10 U	10 U
Acenaphthylene	10 U	10 U	10 U	10 U	10 U	10 U	10 U	10 U	10 U
2,6-Dinitrotoluene	10 U	10 U	10 U	10 U	10 U	10 U	10 U	10 U	10 U
3-Nitroaniline	50 U	50 U	50 U	50 U	50 U	50 U	50 U	50 U	50 U

UNITS UG/L

WAFB Site FT-08: Ground Water Investigation
Validated Results for Semi-Volatile Analyses

SITE LOCATION COMPOUND	CF-7	CF-8	CF-6	CF-5	CF-3	CF-2	CF-4	DUP (CF-7)	EQBLK (6/25/93)
Acenaphthene	10 U	10 U	10 U	10 U	10 U	10 U	10 U	10 U	10 U
2,4-Dinitrophenol	50 U	50 U	50 U	50 U	50 U	50 U	50 U	50 U	50 U
4-Nitrophenol	50 U	50 U	50 U	50 U	50 U	50 U	50 U	50 U	50 U
Dibenzofuran	10 U	10 U	10 U	10 U	10 U	10 U	10 U	10 U	10 U
2,4-Dinitrotoluene	10 U	10 U	10 U	10 U	10 U	10 U	10 U	10 U	10 U
Diethylphthalate	10 U	10 U	10 U	10 U	10 U	10 U	10 U	10 U	10 U
4-Chlorophenyl-phenylether	10 U	10 U	10 U	10 U	10 U	10 U	10 U	10 U	10 U
Fluorene	10 U	10 U	10 U	10 U	10 U	10 U	10 U	10 U	10 U
4-Nitroaniline	50 U	50 U	50 U	50 U	50 U	50 U	50 U	50 U	50 U
4,6-Dinitro-2-methylphenol	50 U	50 U	50 U	50 U	50 U	50 U	50 U	50 U	50 U
N-Nitrosodiphenylamine	10 U	10 U	10 U	10 U	10 U	10 U	10 U	10 U	10 U
4-Bromophenyl-phenylether	10 U	10 U	10 U	10 U	10 U	10 U	10 U	10 U	10 U
Hexachlorobenzene	10 U	10 U	10 U	10 U	10 U	10 U	10 U	10 U	10 U
Pentachlorophenol	30 U	30 U	30 U	30 U	30 U	30 U	30 U	30 U	30 U
Phenanthrene	10 U	10 U	10 U	10 U	10 U	10 U	10 U	10 U	10 U
Anthracene	10 U	10 U	10 U	10 U	10 U	10 U	10 U	10 U	10 U
Di-n-butylphthalate	10 U	10 U	10 U	10 U	10 U	10 U	10 U	10 U	10 U
Fluoranthene	10 U	10 U	10 U	10 U	10 U	10 U	10 U	10 U	10 U
Pyrene	10 U	10 U	10 U	10 U	10 U	10 U	10 U	10 U	10 U
Butylbenzylphthalate	10 U	10 U	10 U	10 U	10 U	10 U	10 U	10 U	10 U
3,3'-Dichlorobenzidine	20 U	20 U	20 U	20 U	20 U	20 U	20 U	20 U	20 U
Benzo(a)anthracene	10 U	10 U	10 U	10 U	10 U	10 U	10 U	10 U	10 U
Chrysene	10 U	10 U	10 U	10 U	10 U	10 U	10 U	10 U	10 U
bis(2-Ethylhexyl)phthalate	10 U	10 U	10 U	10 U	10 U	10 U	10 U	10 U	10 U
Di-n-octylphthalate	10 U	10 U	10 U	10 U	10 U	10 U	10 U	10 U	10 U
Benzo(b)fluoranthene	10 U	10 U	10 U	10 U	10 U	10 U	10 U	10 U	10 U
Benzo(k)fluoranthene	10 U	10 U	10 U	10 U	10 U	10 U	10 U	10 U	10 U
Benzo(a)pyrene	10 U	10 U	10 U	10 U	10 U	10 U	10 U	10 U	10 U
Indeno(1,2,3-cd)pyrene	10 U	10 U	10 U	10 U	10 U	10 U	10 U	10 U	10 U
Dibenzo(a,h)anthracene	10 U	10 U	10 U	10 U	10 U	10 U	10 U	10 U	10 U
Benzo(g,h,i)perylene	10 U	10 U	10 U	10 U	10 U	10 U	10 U	10 U	10 U

UNITS: UG/L

TABLE C7 (PAGE 1 OF 4)

WAFB Site FT-08: Soil Boring Investigation
Validated Results for Semi-Volatile Analyses

SITE LOCATION DEPTH (FEET) COMPOUND	1+0-600R (0-2)	2+0-600R (0-2)	3+0-600R (0-2)	4+0-600R (0-2)	0+0-400R (0-2)	1+0-400R (0-2)	2+0-400R (0-2)	3+0-400R (0-2)	4+0-400R (0-2)
Phenol	390 U	350 U	400 U	410 U	500 U	500 U	510 U	370 U	360 U
bis(2-Chloroethoxy)ether	390 U	350 U	400 U	410 U	500 U	500 U	510 U	370 U	360 U
2-Chlorophenol	390 U	350 U	400 U	410 U	500 U	500 U	510 U	370 U	360 U
1,3-Dichlorobenzene	390 U	350 U	400 U	410 U	500 U	500 U	510 U	370 U	360 U
1,4-Dichlorobenzene	390 U	350 U	400 U	410 U	500 U	500 U	510 U	370 U	360 U
Benzyl alcohol	390 U	350 U	400 U	410 U	500 U	500 U	510 U	370 U	360 U
1,2-Dichlorobenzene	390 U	350 U	400 U	410 U	500 U	500 U	510 U	370 U	360 U
2-Methylphenol	390 U	350 U	400 U	410 U	500 U	500 U	510 U	370 U	360 U
bis(2-chloroisopropyl)ether	390 U	350 U	400 U	410 U	500 U	500 U	510 U	370 U	360 U
3/4-Methylphenol	390 U	350 U	400 U	410 U	500 U	500 U	510 U	370 U	360 U
N-Nitroso-di-n-propylamine	390 U	350 U	400 U	410 U	500 U	500 U	510 U	370 U	360 U
Hexachloroethane	390 U	350 U	400 U	410 U	500 U	500 U	510 U	370 U	360 U
Nitrobenzene	390 U	350 U	400 U	410 U	500 U	500 U	510 U	370 U	360 U
Isophorone	390 U	350 U	400 U	410 U	500 U	500 U	510 U	370 U	360 U
2-Nitrophenol	390 U	350 U	400 U	410 U	500 U	500 U	510 U	370 U	360 U
2,4-Dimethylphenol	390 U	350 U	400 U	410 U	500 U	500 U	510 U	370 U	360 U
Benzic acid	2000 U	1800 U	2100 U	2100 U	2600 U	2600 U	2600 U	1900 U	1900 U
bis(2-Chloroethoxy)methane	390 U	350 U	400 U	410 U	500 U	500 U	510 U	370 U	360 U
2,4-Dichlorophenol	390 U	350 U	400 U	410 U	500 U	500 U	510 U	370 U	360 U
1,2,4-Trichlorobenzene	390 U	350 U	400 U	410 U	500 U	500 U	510 U	370 U	360 U
Naphthalene	390 U	350 U	400 U	410 U	500 U	500 U	510 U	370 U	360 U
4-Chloroaniline	390 U	350 U	400 U	410 U	500 U	500 U	510 U	370 U	360 U
Hexachlorobutadiene	390 U	350 U	400 U	410 U	500 U	500 U	510 U	370 U	360 U
4-Chloro-3-methylphenol	390 U	350 U	400 U	410 U	500 U	500 U	510 U	370 U	360 U
2-Methylnaphthalene	390 U	350 U	400 U	410 U	500 U	500 U	510 U	370 U	360 U
Hexachlorocyclopentadiene	390 U	350 U	400 U	410 U	500 U	500 U	510 U	370 U	360 U
2,4,6-Trichlorophenol	390 U	350 U	400 U	410 U	500 U	500 U	510 U	370 U	360 U
2,4,5-Trichlorophenol	2000 U	1800 U	2100 U	2100 U	2600 U	2600 U	2600 U	1900 U	1900 U
2-Chloronaphthalene	390 U	350 U	400 U	410 U	500 U	500 U	510 U	370 U	360 U
2-Nitroaniline	2000 U	1800 U	2100 U	2100 U	2600 U	2600 U	2600 U	1900 U	1900 U
Dimethylphthalate	390 U	350 U	400 U	410 U	500 U	500 U	510 U	370 U	360 U
Acenaphthylene	390 U	350 U	400 U	410 U	500 U	500 U	510 U	370 U	360 U
2,6-Dinitrotoluene	390 U	350 U	400 U	410 U	500 U	500 U	510 U	370 U	360 U
3-Nitroaniline	2000 U	1800 U	2100 U	2100 U	2600 U	2600 U	2600 U	1900 U	1900 U

UNITS UG/KG DRY WEIGHT
* UG/L

TABLE C7 (PAGE 2 OF 4)

WAFB Site FT-08: Soil Boring Investigation
Validated Results for Semi-Volatile Analyses

SITE LOCATION DEPTH (FEET) COMPOUND	1+0-600R (0-2)	2+0-600R (0-2)	3+0-600R (0-2)	4+0-600R (0-2)	0+0-400R (0-2)	1+0-400R (0-2)	2+0-400R (0-2)	3+0-400R (0-2)	4+0-400R (0-2)
Acenaphthene	390 U	350 U	400 U	410 U	500 U	500 U	510 U	370 U	360 U
2,4-Dinitrophenol	2000 U	1800 U	2100 U	2100 U	2600 U	2600 U	2600 U	1900 U	1900 U
4-Nitrophenol	2000 U	1800 U	2100 U	2100 U	2600 U	2600 U	2600 U	1900 U	1900 U
Dibenzofuran	390 U	350 U	400 U	410 U	500 U	500 U	510 U	370 U	360 U
2,4-Dinitrotoluene	390 U	350 U	400 U	410 U	500 U	500 U	510 U	370 U	360 U
1,2,3,4-Tetrahydrophthalate	390 U	350 U	400 U	410 U	500 U	500 U	510 U	370 U	360 U
Chlorophenyl-phenylether	390 U	350 U	400 U	410 U	500 U	500 U	510 U	370 U	360 U
Fluorene	390 U	350 U	400 U	410 U	500 U	500 U	510 U	370 U	360 U
4-Nitroaniline	2000 U	1800 U	2100 U	2100 U	2600 U	2600 U	2600 U	1900 U	1900 U
4,6-Dinitro-2-methylphenol	2000 U	1800 U	2100 U	2100 U	2600 U	2600 U	2600 U	1900 U	1900 U
N-Nitrosodiphenylamine	390 U	350 U	400 U	410 U	500 U	500 U	510 U	370 U	360 U
4-Bromophenyl-phenylether	390 U	350 U	400 U	410 U	500 U	500 U	510 U	370 U	360 U
Hexachlorobenzene	390 U	350 U	400 U	410 U	500 U	500 U	510 U	370 U	360 U
Pentachlorophenol	1200 U	1100 U	1200 U	1200 U	1500 U	1500 U	1600 U	1100 U	1100 U
Phenanthrene	390 U	350 U	400 U	410 U	500 U	500 U	510 U	370 U	360 U
Anthracene	390 U	350 U	400 U	410 U	500 U	500 U	510 U	370 U	360 U
Di-n-butylphthalate	390 U	350 U	400 U	410 U	500 U	500 U	510 U	370 U	360 U
Fluoranthene	390 U	350 U	400 U	410 U	500 U	500 U	510 U	370 U	360 U
Pyrene	390 U	350 U	400 U	410 U	500 U	500 U	510 U	370 U	360 U
Butylbenzylphthalate	390 U	350 U	400 U	410 U	500 U	500 U	510 U	370 U	360 U
3,3'-Dichlorobenzidine	800 U	720 U	820 U	820 U	1000 U	1000 U	1000 U	750 U	740 U
Benzo(a)anthracene	390 U	350 U	400 U	410 U	500 U	500 U	510 U	370 U	360 U
1,2-Ethylhexylphthalate	390 U	350 U	400 U	410 U	500 U	500 U	510 U	370 U	360 U
Di-n-octylphthalate	390 U	350 U	400 U	410 U	500 U	500 U	510 U	370 U	360 U
Benzo(b)fluoranthene	390 U	350 U	400 U	410 U	500 U	500 U	510 U	370 U	360 U
Benzo(k)fluoranthene	390 U	350 U	400 U	410 U	500 U	500 U	510 U	370 U	360 U
Benzo(a)pyrene	390 U	350 U	400 U	410 U	500 U	500 U	510 U	370 U	360 U
Indeno(1,2,3-cd)pyrene	390 U	350 U	400 U	410 U	500 U	500 U	510 U	370 U	360 U
Dibenz(a,h)anthracene	390 U	350 U	400 U	410 U	500 U	500 U	510 U	370 U	360 U
Benzo(g,h,i)perylene	390 U	350 U	400 U	410 U	500 U	500 U	510 U	370 U	360 U

UNITS: UG/KG DRY WEIGHT
* UG/L

WAFB Site FT-08: Soil Boring Investigation
Validated Results for Semi-Volatile Analyses

SITE LOCATION DEPTH (FEET) COMPOUND	0+0-500R (0-2)	1+0-500R (0-2)	2+0-500R (0-2)	DUP (0-2) (1+0-500R)	EQBLK* 6/23/93
Phenol	450 U	380 U	400 U	360 U	10 U
bis(2-Chloroethyl)ether	450 U	380 U	400 U	360 U	10 U
2-Chlorophenol	450 U	380 U	400 U	360 U	10 U
1,3-Dichlorobenzene	450 U	380 U	400 U	360 U	10 U
1,4-Dichlorobenzene	450 U	380 U	400 U	360 U	10 U
Benzyl alcohol	450 U	380 U	400 U	360 U	10 U
1,2-Dichlorobenzene	450 U	380 U	400 U	360 U	10 U
2-Methylphenol	450 U	380 U	400 U	360 U	10 U
bis(2-chloroisopropyl)ether	450 U	380 U	400 U	360 U	10 U
4-Methylphenol	450 U	380 U	400 U	360 U	10 U
N-Nitroso-di-n-propylamine	450 U	380 U	400 U	360 U	10 U
Hexachloroethane	450 U	380 U	400 U	360 U	10 U
Nitrobenzene	450 U	380 U	400 U	360 U	10 U
Isophorone	450 U	380 U	400 U	360 U	10 U
2-Nitrophenol	450 U	380 U	400 U	360 U	10 U
2,4-Dimethylphenol	450 U	380 U	400 U	360 U	10 U
Benzoic acid	2300 U	2000 U	2000 U	1800 U	50 U
bis(2-Chloroethoxy)methane	450 U	380 U	400 U	360 U	10 U
2,4-Dichlorophenol	450 U	380 U	400 U	360 U	10 U
1,2,4-Trichlorobenzene	450 U	380 U	400 U	360 U	10 U
Naphthalene	450 U	380 U	400 U	360 U	10 U
4-Chloroaniline	450 U	380 U	400 U	360 U	10 U
Hexachlorobutadiene	450 U	380 U	400 U	360 U	10 U
4-Chloro-3-methylphenol	450 U	380 U	400 U	360 U	10 U
2-Methylnaphthalene	450 U	380 U	400 U	360 U	10 U
Hexachlorocyclopentadiene	450 U	380 U	400 U	360 U	10 U
4,6-Trichlorophenol	450 U	380 U	400 U	360 U	10 U
2,4,5-Trichlorophenol	2300 U	2000 U	2000 U	2000 U	50 U
2-Chloronaphthalene	450 U	380 U	400 U	360 U	10 U
2-Nitroaniline	2300 U	2000 U	2000 U	1800 U	50 U
Dimethylphthalate	450 U	380 U	400 U	360 U	10 U
Acenaphthylene	450 U	380 U	400 U	360 U	10 U
2,6-Dinitrotoluene	450 U	380 U	400 U	360 U	10 U
3-Nitroaniline	2300 U	2000 U	2000 U	1800 U	50 U

UNITS UG/KG DRY WEIGHT
* UG/L

TABLE C7 (PAGE 4 OF 4)

WAFB Site FT-08: Soil Boring Investigation
Validated Results for Semi-Volatile Analyses

SITE LOCATION DEPTH (FEET) COMPOUND	0+0-500R (0-2)	1+0-500R (0-2)	2+0-500R (0-2)	DUP (0-2) (1+0-500R)	EQBLK 6/23/93
Acenaphthene	450 U	380 U	400 U	360 U	10 U
2,4-Dinitrophenol	2300 U	2000 U	2000 U	1800 U	50 U
4-Nitrophenol	2300 U	2000 U	2000 U	1800 U	50 U
Dibenzofuran	450 U	380 U	400 U	360 U	10 U
2,4-Dinitrotoluene	450 U	380 U	400 U	360 U	10 U
1,2,3,4-tetrahydrophthalate	450 U	380 U	400 U	360 U	10 U
Chlorophenyl-phenylether	450 U	380 U	400 U	360 U	10 U
Fluorene	450 U	380 U	400 U	360 U	10 U
4-Nitroaniline	2300 U	2000 U	2000 U	1800 U	50 U
4,6-Dinitro-2-methylphenol	2300 U	2000 U	2000 U	1800 U	50 U
N-Nitrosodiphenylamine	450 U	380 U	400 U	360 U	10 U
4-Bromophenyl-phenylether	450 U	380 U	400 U	360 U	10 U
Hexachlorobenzene	450 U	380 U	400 U	360 U	10 U
Pentachlorophenol	1400 U	1200 U	1200 U	1100 U	30 U
Phenanthrene	450 U	380 U	400 U	360 U	10 U
Anthracene	450 U	380 U	400 U	360 U	10 U
Di-n-butylphthalate	450 U	380 U	400 U	360 U	10 U
Fluoranthene	450 U	380 U	400 U	360 U	10 U
Pyrene	450 U	380 U	400 U	360 U	10 U
Butylbenzylphthalate	450 U	380 U	400 U	360 U	10 U
3,3'-Dichlorobenzidine	920 U	780 U	810 U	730 U	20 U
Benzo(a)anthracene	450 U	380 U	400 U	360 U	10 U
Benzo(b)fluoranthene	450 U	380 U	400 U	360 U	10 U
Benzo(k)fluoranthene	450 U	380 U	400 U	360 U	10 U
Benzo(a)pyrene	450 U	380 U	400 U	360 U	10 U
Indeno(1,2,3-cd)pyrene	450 U	380 U	400 U	360 U	10 U
Dibenz(a,h)anthracene	450 U	380 U	400 U	360 U	10 U
Benzo(g,h,i)perylene	450 U	380 U	400 U	360 U	10 U

UNITS: UG/KG DRY WEIGHT
• UG/L

TABLE 4.15
SUMMARY OF SOIL BORING ANALYSES
CURRENT FIRE TRAINING AREA

Analysis	CFS-1		CFS-2		CFS-3		CFS-4		CFS-5		CFS-6	
	Units	Detection Limits	Units	Detection Limits	Units	Detection Limits	Units	Detection Limits	Units	Detection Limits	Units	Detection Limits
<u>Halogenated Organics - SW 8010</u>												
Dichloromethane	mg/kg	1.1 ^a	1.2 ^a	3.3 ^a	3.6 ^a	1.5 ^a	2.0 ^a	2.1 ^a	4.6 ^a	2.2 ^a	2.3 ^a	1.9 ^a
Other Compounds	mg/kg	-	-	-	-	-	-	-	-	-	-	-
<u>Aromatic Organics - SW 8020</u>												
Benzene	mg/kg	-	13	10	6	8.5	16	14	14	-	84	-
Toluene	mg/kg	19	1.3	-	-	1.1	1.8	-	1.7	-	6.2	-
Other Compounds	mg/kg	-	-	-	-	-	-	-	-	-	-	-
<u>Petroleum Hydrocarbons - E-418.1</u>												
	mg/g	76	0.56	1.8	-	-	-	43	-	-	-	-
<u>Halogenated Organics - SW 8010</u>												
Dichloromethane	mg/kg	3.8 ^a	3.1 ^a	3.1 ^a	2.9 ^a	1.6 ^a	1.4 ^a	-	1.1 ^a	1.2 ^a	-	-
Other Compounds	mg/kg	-	-	-	-	-	-	-	-	-	-	-
<u>Aromatic Organics - SW 8020</u>												
All Compounds	mg/kg	-	-	-	-	-	-	-	-	-	-	-
<u>Petroleum Hydrocarbons</u>												
- E418.1	mg/g	-	-	-	0.52	0.74	102	1.2	0.85	0.44	-	-

a - Compound also present in laboratory blank.
Compounds not detected are indicated by a dash.
Foot Note: Blank spaces indicate sample was not analyzed.
* - Applicable analytical holding times exceeded and/or failed to pass QC review.

ES 86

APPENDIX B - 3

**Summary of Groundwater
Analytical Data
Site FT-08**

Source: O'Brien and Gere, 1995.



Environmental Services

Volatile Organic Compounds Method SW8240

Client Name: O'Brien & Gere Engineers, Inc.
Client ID: TF-1A (0.00,0.00,)
LAB ID: 109364-0001-SA
Matrix: GRND-H2O
Authorized: 30 DEC 94
Instrument: GC/MS-MH

Sampled: 29 DEC 94
Prepared: 03 JAN 95
Dilution: 1.0

Received: 30 DEC 94
Analyzed: 03 JAN 95

Table with 5 columns: Parameter, Result, Qualifier, RL, Units. Lists various chemical compounds and their detection results (e.g., Chloromethane ND, RL 10 ug/L).

Table with 4 columns: Surrogate, Recovery, %, Acceptable Range. Lists surrogate compounds and their recovery percentages (e.g., 1,2-Dichloroethane-d4 98% recovery).

ND = Not Detected

Volatile Organic Compounds
Method SW8240

Client Name: O'Brien & Gere Engineers, Inc.

Client ID: TF-2 (0.00,0.00,)

LAB ID: 109364-0004-SA

Matrix: GRND-H2O

Authorized: 30 DEC 94

Instrument: GC/MS-MH

Sampled: 29 DEC 94

Prepared: 03 JAN 95

Dilution: 1.0

Received: 30 DEC 94

Analyzed: 03 JAN 95

Parameter	Result	Qualifier	RL	Units
Chloromethane	ND		10	ug/L
Bromomethane	ND		10	ug/L
Vinyl chloride	ND		10	ug/L
Chloroethane	ND		10	ug/L
Methylene chloride	3.3	J	5.0	ug/L
Acetone	ND		10	ug/L
Carbon disulfide	ND		5.0	ug/L
1,1-Dichloroethene	ND		5.0	ug/L
1,1-Dichloroethane	ND		5.0	ug/L
1,2-Dichloroethene (Total)	ND		5.0	ug/L
Chloroform	ND		5.0	ug/L
1,2-Dichloroethane	ND		5.0	ug/L
2-Butanone (MEK)	ND		10	ug/L
1,1,1-Trichloroethane	ND		5.0	ug/L
Carbon tetrachloride	ND		5.0	ug/L
Vinyl acetate	ND		10	ug/L
Bromodichloromethane	ND		5.0	ug/L
1,2-Dichloropropane	ND		5.0	ug/L
cis-1,3-Dichloropropene	ND		5.0	ug/L
Trichloroethene	ND		5.0	ug/L
Dibromochloromethane	ND		5.0	ug/L
1,1,2-Trichloroethane	ND		5.0	ug/L
Benzene	ND		5.0	ug/L
trans-1,3-Dichloropropene	ND		5.0	ug/L
2-Chloroethyl vinyl ether	ND		10	ug/L
Bromoform	ND		5.0	ug/L
4-Methyl-2-pentanone (MIBK)	ND		10	ug/L
2-Hexanone	ND		10	ug/L
Tetrachloroethene	ND		5.0	ug/L
1,1,2,2-Tetrachloroethane	ND		5.0	ug/L
Toluene	ND		5.0	ug/L
Chlorobenzene	ND		5.0	ug/L
Ethylbenzene	ND		5.0	ug/L
Styrene	ND		5.0	ug/L
Xylenes (total)	ND		5.0	ug/L
Surrogate	Recovery		Acceptable Range	
1,2-Dichloroethane-d4	101	%	79 - 127	
Toluene-d8	104	%	88 - 110	
Bromofluorobenzene	101	%	86 - 115	

J = Result is detected below the reporting limit or is an estimated concentration.

ND = Not Detected

Volatile Organic Compounds
Method SW8240

Client Name: O'Brien & Gere Engineers, Inc.

Client ID: TF-2A (0.00,0.00,)

LAB ID: 109364-0003-SA

Matrix: GRND-H2O

Sampled: 29 DEC 94

Received: 30 DEC 94

Authorized: 30 DEC 94

Prepared: 03 JAN 95

Analyzed: 03 JAN 95

Instrument: GC/MS-MH

Dilution: 1.0

Parameter	Result	Qualifier	RL	Units
Chloromethane	ND		10	ug/L
Bromomethane	ND		10	ug/L
Vinyl chloride	ND		10	ug/L
Chloroethane	ND		10	ug/L
Methylene chloride	ND		5.0	ug/L
Acetone	ND		10	ug/L
Carbon disulfide	ND		5.0	ug/L
1,1-Dichloroethene	ND		5.0	ug/L
1,1-Dichloroethane	ND		5.0	ug/L
1,2-Dichloroethene (Total)	26		5.0	ug/L
Chloroform	ND		5.0	ug/L
1,2-Dichloroethane	ND		5.0	ug/L
2-Butanone (MEK)	ND		10	ug/L
1,1,1-Trichloroethane	ND		5.0	ug/L
Carbon tetrachloride	ND		5.0	ug/L
Vinyl acetate	ND		10	ug/L
Bromodichloromethane	ND		5.0	ug/L
1,2-Dichloropropane	ND		5.0	ug/L
cis-1,3-Dichloropropene	ND		5.0	ug/L
Trichloroethene	ND		5.0	ug/L
Dibromochloromethane	ND		5.0	ug/L
1,1,2-Trichloroethane	ND		5.0	ug/L
Benzene	3.6	J	5.0	ug/L
trans-1,3-Dichloropropene	ND		5.0	ug/L
2-Chloroethyl vinyl ether	ND		10	ug/L
Bromoform	ND		5.0	ug/L
4-Methyl-2-pentanone (MIBK)	ND		10	ug/L
2-Hexanone	ND		10	ug/L
Tetrachloroethene	ND		5.0	ug/L
1,1,2,2-Tetrachloroethane	ND		5.0	ug/L
Toluene	27		5.0	ug/L
Chlorobenzene	ND		5.0	ug/L
Ethylbenzene	240		5.0	ug/L
Styrene	ND		5.0	ug/L
Xylenes (total)	370		5.0	ug/L

Surrogate	Recovery		Acceptable Range
1,2-Dichloroethane-d4	101	%	79 - 127
Toluene-d8	103	%	88 - 110
Bromofluorobenzene	105	%	86 - 115

J = Result is detected below the reporting limit or is an estimated concentration.
 ND = Not Detected

Volatile Organic Compounds
Method SW8240

Client Name: O'Brien & Gere Engineers, Inc.

Client ID: TF-3 (0.00,0.00,)

LAB ID: 109364-0002-SA

Matrix: GRND-H2O

Sampled: 29 DEC 94

Received: 30 DEC 94

Authorized: 30 DEC 94

Prepared: 03 JAN 95

Analyzed: 03 JAN 95

Instrument: GC/MS-MH

Dilution: 1.0

Parameter	Result	Qualifier	RL	Units
Chloromethane	ND		10	ug/L
Bromomethane	ND		10	ug/L
Vinyl chloride	ND		10	ug/L
Chloroethane	ND		10	ug/L
Methylene chloride	ND		5.0	ug/L
Acetone	ND		10	ug/L
Carbon disulfide	ND		5.0	ug/L
1,1-Dichloroethene	ND		5.0	ug/L
1,1-Dichloroethane	ND		5.0	ug/L
1,2-Dichloroethene (Total)	ND		5.0	ug/L
Chloroform	ND		5.0	ug/L
1,2-Dichloroethane	ND		5.0	ug/L
2-Butanone (MEK)	ND		10	ug/L
1,1,1-Trichloroethane	ND		5.0	ug/L
Carbon tetrachloride	ND		5.0	ug/L
Vinyl acetate	ND		10	ug/L
Bromodichloromethane	ND		5.0	ug/L
1,2-Dichloropropane	ND		5.0	ug/L
cis-1,3-Dichloropropene	ND		5.0	ug/L
Trichloroethene	ND		5.0	ug/L
Dibromochloromethane	ND		5.0	ug/L
1,1,2-Trichloroethane	ND		5.0	ug/L
Benzene	ND		5.0	ug/L
trans-1,3-Dichloropropene	ND		5.0	ug/L
2-Chloroethyl vinyl ether	ND		10	ug/L
Bromoform	ND		5.0	ug/L
4-Methyl-2-pentanone (MIBK)	ND		10	ug/L
2-Hexanone	ND		10	ug/L
Tetrachloroethene	ND		5.0	ug/L
1,1,2,2-Tetrachloroethane	ND		5.0	ug/L
Toluene	ND		5.0	ug/L
Chlorobenzene	ND		5.0	ug/L
Ethylbenzene	ND		5.0	ug/L
Styrene	ND		5.0	ug/L
Xylenes (total)	ND		5.0	ug/L

Surrogate	Recovery		Acceptable Range
1,2-Dichloroethane-d4	96	%	79 - 127
Toluene-d8	103	%	88 - 110
Bromofluorobenzene	98	%	86 - 115

ND = Not Detected

Volatile Organic Compounds
Method SW8240

Client Name: O'Brien & Gere Engineers, Inc.
Client ID: TF-5 (0.00,0.00,)
LAB ID: 109394-0004-SA
Matrix: GRND-H2O
Authorized: 04 JAN 95
Instrument: GC/MS-MF

Sampled: 03 JAN 95
Prepared: 05 JAN 95
Dilution: 1.0

Received: 04 JAN 95
Analyzed: 05 JAN 95

Parameter	Result	Qualifier	RL	Units
Chloromethane	ND		10	ug/L
Bromomethane	ND		10	ug/L
Vinyl chloride	ND		10	ug/L
Chloroethane	ND		10	ug/L
Methylene chloride	ND		10	ug/L
Acetone	ND		5.0	ug/L
Carbon disulfide	ND		10	ug/L
1,1-Dichloroethene	ND		5.0	ug/L
1,1-Dichloroethane	ND		5.0	ug/L
1,2-Dichloroethene (Total)	ND		5.0	ug/L
Chloroform	2.0	J	5.0	ug/L
1,2-Dichloroethane	ND		5.0	ug/L
2-Butanone (MEK)	ND		5.0	ug/L
1,1,1-Trichloroethane	ND		10	ug/L
Carbon tetrachloride	ND		5.0	ug/L
Vinyl acetate	ND		5.0	ug/L
Bromodichloromethane	ND		10	ug/L
1,2-Dichloropropane	ND		5.0	ug/L
cis-1,3-Dichloropropene	ND		5.0	ug/L
Trichloroethene	ND		5.0	ug/L
Dibromochloromethane	ND		5.0	ug/L
1,1,2-Trichloroethane	ND		5.0	ug/L
Benzene	ND		5.0	ug/L
trans-1,3-Dichloropropene	ND		5.0	ug/L
2-Chloroethyl vinyl ether	ND		5.0	ug/L
Bromoform	ND		10	ug/L
4-Methyl-2-pentanone (MIBK)	ND		5.0	ug/L
2-Hexanone	ND		10	ug/L
Tetrachloroethene	ND		10	ug/L
1,1,2,2-Tetrachloroethane	ND		5.0	ug/L
Toluene	ND		5.0	ug/L
Chlorobenzene	ND		5.0	ug/L
Ethylbenzene	ND		5.0	ug/L
Styrene	1.5	J	5.0	ug/L
Xylenes (total)	ND		5.0	ug/L
	ND		5.0	ug/L

Surrogate	Recovery		Acceptable Range
1,2-Dichloroethane-d4	102	%	79 - 127
Toluene-d8	103	%	88 - 110
Bromofluorobenzene	102	%	86 - 115

J = Result is detected below the reporting limit or is an estimated concentration.
ND = Not Detected

Volatile Organic Compounds
Method SW8240

Client Name: O'Brien & Gere Engineers, Inc.
 Client ID: TF-7 (0.00,0.00,)
 LAB ID: 109394-0003-SA
 Matrix: GRND-H2O
 Authorized: 04 JAN 95
 Instrument: GC/MS-MF

Sampled: 03 JAN 95
 Prepared: 05 JAN 95
 Dilution: 1.0

Received: 04 JAN 95
 Analyzed: 05 JAN 95

Parameter	Result	Qualifier	RL	Units
Chloromethane	ND		10	ug/L
Bromomethane	ND		10	ug/L
Vinyl chloride	ND		10	ug/L
Chloroethane	ND		10	ug/L
Methylene chloride	ND		10	ug/L
Acetone	ND		5.0	ug/L
Carbon disulfide	ND		10	ug/L
1,1-Dichloroethene	ND		5.0	ug/L
1,1-Dichloroethane	ND		5.0	ug/L
1,2-Dichloroethene (Total)	ND		5.0	ug/L
Chloroform	ND		5.0	ug/L
1,2-Dichloroethane	ND		5.0	ug/L
2-Butanone (MEK)	ND		5.0	ug/L
1,1,1-Trichloroethane	ND		10	ug/L
Carbon tetrachloride	ND		5.0	ug/L
Vinyl acetate	ND		5.0	ug/L
Bromodichloromethane	ND		10	ug/L
1,2-Dichloropropane	ND		5.0	ug/L
cis-1,3-Dichloropropene	ND		5.0	ug/L
Trichloroethene	ND		5.0	ug/L
Dibromochloromethane	ND		5.0	ug/L
1,1,2-Trichloroethane	ND		5.0	ug/L
Benzene	ND		5.0	ug/L
trans-1,3-Dichloropropene	ND		5.0	ug/L
2-Chloroethyl vinyl ether	ND		5.0	ug/L
Bromoform	ND		10	ug/L
4-Methyl-2-pentanone (MIBK)	ND		5.0	ug/L
2-Hexanone	ND		10	ug/L
Tetrachloroethene	ND		10	ug/L
1,1,2,2-Tetrachloroethane	ND		5.0	ug/L
Toluene	ND		5.0	ug/L
Chlorobenzene	ND		5.0	ug/L
Ethylbenzene	ND		5.0	ug/L
Styrene	ND		5.0	ug/L
Xylenes (total)	ND		5.0	ug/L
	ND		5.0	ug/L
Surrogate	Recovery		Acceptable Range	
1,2-Dichloroethane-d4	99	%	79 - 127	
Toluene-d8	100	%	88 - 110	
Bromofluorobenzene	98	%	86 - 115	

ND = Not Detected



Environmental Services

Volatile Organic Compounds Method SW8240

Client Name: O'Brien & Gere Engineers, Inc.

Client ID: TF-8 (0.00,0.00,)

LAB ID: 109394-0002-SA

Matrix: GRND-H2O

Authorized: 04 JAN 95

Instrument: GC/MS-MF

Sampled: 03 JAN 95

Prepared: 05 JAN 95

Dilution: 1.0

Received: 04 JAN 95

Analyzed: 05 JAN 95

Parameter	Result	Qualifier	RL	Units
Chloromethane	ND		10	ug/L
Bromomethane	ND		10	ug/L
Vinyl chloride	ND		10	ug/L
Chloroethane	ND		10	ug/L
Methylene chloride	ND		5.0	ug/L
Acetone	ND		10	ug/L
Carbon disulfide	ND		5.0	ug/L
1,1-Dichloroethene	ND		5.0	ug/L
1,1-Dichloroethane	ND		5.0	ug/L
1,2-Dichloroethene (Total)	1.4	J	5.0	ug/L
Chloroform	ND		5.0	ug/L
1,2-Dichloroethane	ND		5.0	ug/L
2-Butanone (MEK)	ND		10	ug/L
1,1,1-Trichloroethane	ND		5.0	ug/L
Carbon tetrachloride	ND		5.0	ug/L
Vinyl acetate	ND		10	ug/L
Bromodichloromethane	ND		5.0	ug/L
1,2-Dichloropropane	ND		5.0	ug/L
cis-1,3-Dichloropropene	ND		5.0	ug/L
Trichloroethene	1.4	J	5.0	ug/L
Dibromochloromethane	ND		5.0	ug/L
1,1,2-Trichloroethane	ND		5.0	ug/L
Benzene	ND		5.0	ug/L
trans-1,3-Dichloropropene	ND		5.0	ug/L
2-Chloroethyl vinyl ether	ND		10	ug/L
Bromoform	ND		5.0	ug/L
4-Methyl-2-pentanone (MIBK)	ND		10	ug/L
2-Hexanone	ND		10	ug/L
Tetrachloroethene	ND		5.0	ug/L
1,1,2,2-Tetrachloroethane	ND		5.0	ug/L
Toluene	ND		5.0	ug/L
Chlorobenzene	ND		5.0	ug/L
Ethylbenzene	ND		5.0	ug/L
Styrene	ND		5.0	ug/L
Xylenes (total)	ND		5.0	ug/L

Surrogate	Recovery		Acceptable Range
1,2-Dichloroethane-d4	97	%	79 - 127
Toluene-d8	98	%	88 - 110
Bromofluorobenzene	98	%	86 - 115

J = Result is detected below the reporting limit or is an estimated concentration.
ND = Not Detected

Volatile Organic Compounds
Method SW8240

Client Name: O'Brien & Gere Engineers, Inc.

Client ID: TF-11 (0.00,0.00,)

LAB ID: 109394-0001-SA

Matrix: GRND-H2O

Sampled: 03 JAN 95

Received: 04 JAN 95

Authorized: 04 JAN 95

Prepared: 05 JAN 95

Analyzed: 05 JAN 95

Instrument: PTGC/MS

Dilution: 1.0

Parameter	Result	Qualifier	RL	Units
Chloromethane	ND		10	ug/L
Bromomethane	ND		10	ug/L
Vinyl chloride	ND		10	ug/L
Chloroethane	ND		10	ug/L
Methylene chloride	ND		5.0	ug/L
Acetone	ND		10	ug/L
Carbon disulfide	ND		5.0	ug/L
1,1-Dichloroethene	ND		5.0	ug/L
1,1-Dichloroethane	ND		5.0	ug/L
1,2-Dichloroethene (Total)	15		5.0	ug/L
Chloroform	ND		5.0	ug/L
1,2-Dichloroethane	ND		5.0	ug/L
2-Butanone (MEK)	ND		10	ug/L
1,1,1-Trichloroethane	ND		5.0	ug/L
Carbon tetrachloride	ND		5.0	ug/L
Vinyl acetate	ND		10	ug/L
Bromodichloromethane	ND		5.0	ug/L
1,2-Dichloropropane	ND		5.0	ug/L
cis-1,3-Dichloropropene	ND		5.0	ug/L
Trichloroethene	ND		5.0	ug/L
Dibromochloromethane	ND		5.0	ug/L
1,1,2-Trichloroethane	ND		5.0	ug/L
Benzene	1.4	J	5.0	ug/L
trans-1,3-Dichloropropene	ND		5.0	ug/L
2-Chloroethyl vinyl ether	ND		10	ug/L
Bromoform	ND		5.0	ug/L
4-Methyl-2-pentanone (MIBK)	ND		10	ug/L
2-Hexanone	ND		10	ug/L
Tetrachloroethene	ND		5.0	ug/L
1,1,2,2-Tetrachloroethane	ND		5.0	ug/L
Toluene	0.94	J	5.0	ug/L
Chlorobenzene	ND		5.0	ug/L
Ethylbenzene	69		5.0	ug/L
Styrene	ND		5.0	ug/L
Xylenes (total)	7.6		5.0	ug/L

Surrogate	Recovery		Acceptable Range
1,2-Dichloroethane-d4	103	%	79 - 127
Toluene-d8	103	%	88 - 110
Bromofluorobenzene	103	%	86 - 115

J = Result is detected below the reporting limit or is an estimated concentration.
ND = Not Detected

Semivolatile Organic Compounds
Method SW8270

Client Name: O'Brien & Gere Engineers, Inc.

Client ID: TF-1A (0.00,0.00,)

LAB ID: 109364-0001-SA

Matrix: GRND-H2O

Sampled: 29 DEC 94

Received: 30 DEC 94

Authorized: 30 DEC 94

Prepared: 30 DEC 94

Analyzed: 03 JAN 95

Instrument: GC/MS-MA

Dilution: 1.0

Parameter	Result	Qualifier	RL	Units
Phenol	ND		10	ug/L
bis(2-Chloroethyl) ether	ND		10	ug/L
2-Chlorophenol	ND		10	ug/L
1,3-Dichlorobenzene	ND		10	ug/L
1,4-Dichlorobenzene	ND		10	ug/L
Benzyl alcohol	ND		10	ug/L
1,2-Dichlorobenzene	ND		10	ug/L
2-Methylphenol	ND		10	ug/L
bis(2-Chloroisopropyl)-ether	ND		10	ug/L
3/4-Methylphenol	ND		10	ug/L
N-Nitroso-di-n-propylamine	ND		10	ug/L
Hexachloroethane	ND		10	ug/L
Nitrobenzene	ND		10	ug/L
Isophorone	ND		10	ug/L
2-Nitrophenol	ND		10	ug/L
2,4-Dimethylphenol	ND		10	ug/L
Benzoic acid	ND		50	ug/L
bis(2-Chloroethoxy)-methane	ND		10	ug/L
2,4-Dichlorophenol	ND		10	ug/L
1,2,4-Trichlorobenzene	ND		10	ug/L
Naphthalene	ND		10	ug/L
4-Chloroaniline	ND		10	ug/L
Hexachlorobutadiene	ND		10	ug/L
4-Chloro-3-methylphenol	ND		10	ug/L
2-Methylnaphthalene	ND		10	ug/L
Hexachlorocyclopentadiene	ND		10	ug/L
2,4,6-Trichlorophenol	ND		10	ug/L
2,4,5-Trichlorophenol	ND		50	ug/L
2-Chloronaphthalene	ND		10	ug/L
2-Nitroaniline	ND		50	ug/L
Dimethyl phthalate	ND		10	ug/L
Acenaphthylene	ND		10	ug/L
2,6-Dinitrotoluene	ND		10	ug/L
3-Nitroaniline	ND		50	ug/L
Acenaphthene	ND		10	ug/L
2,4-Dinitrophenol	ND		50	ug/L
4-Nitrophenol	ND		50	ug/L
Dibenzofuran	ND		10	ug/L
2,4-Dinitrotoluene	ND		10	ug/L
Diethyl phthalate	ND		10	ug/L
4-Chlorophenyl phenyl ether	ND		10	ug/L
Fluorene	ND		10	ug/L
4-Nitroaniline	ND		50	ug/L
4,6-Dinitro-2-methylphenol	ND		50	ug/L
N-Nitrosodiphenylamine	ND		10	ug/L
4-Bromophenyl phenyl ether	ND		10	ug/L

ND = Not Detected



Environmental Services (cont.)

Semivolatile Organic Compounds Method SW8270

Client Name: O'Brien & Gere Engineers, Inc.
Client ID: TF-1A (0.00,0.00,)
LAB ID: 109364-0001-SA
Matrix: GRND-H2O
Authorized: 30 DEC 94
Instrument: GC/MS-MA
Sampled: 29 DEC 94
Prepared: 30 DEC 94
Dilution: 1.0
Received: 30 DEC 94
Analyzed: 03 JAN 95

Table with columns: Parameter, Result, Qualifier, RL, Units. Lists various organic compounds like Hexachlorobenzene, Pentachlorophenol, Phenanthrene, Anthracene, Di-n-butyl phthalate, Fluoranthene, Pyrene, Butyl benzyl phthalate, 3,3'-Dichlorobenzidine, Benzo(a)anthracene, Chrysene, bis(2-Ethylhexyl)-phthalate, Di-n-octyl phthalate, Benzo(b)fluoranthene, Benzo(k)fluoranthene, Benzo(a)pyrene, Indeno(1,2,3-c,d)pyrene, Dibenz(a,h)anthracene, Benzo(g,h,i)perylene. Includes a Surrogate section with Recovery and Acceptable Range columns.

ND = Not Detected

Semivolatile Organic Compounds
Method SW8270

Client Name: O'Brien & Gere Engineers, Inc.
 Client ID: TF-2 (0.00,0.00,)
 LAB ID: 109364-0004-SA
 Matrix: GRND-H2O
 Authorized: 30 DEC 94
 Instrument: GC/MS-MA

Sampled: 29 DEC 94
 Prepared: 30 DEC 94
 Dilution: 1.0

Received: 30 DEC 94
 Analyzed: 03 JAN 95

Parameter	Result	Qualifier	RL	Units
Phenol	ND		10	ug/L
bis(2-Chloroethyl) ether	ND		10	ug/L
2-Chlorophenol	ND		10	ug/L
1,3-Dichlorobenzene	ND		10	ug/L
1,4-Dichlorobenzene	ND		10	ug/L
Benzyl alcohol	ND		10	ug/L
1,2-Dichlorobenzene	ND		10	ug/L
2-Methylphenol	ND		10	ug/L
bis(2-Chloroisopropyl)-ether	ND		10	ug/L
3/4-Methylphenol	ND		10	ug/L
N-Nitroso-di-n-propylamine	ND		10	ug/L
Hexachloroethane	ND		10	ug/L
Nitrobenzene	ND		10	ug/L
Isophorone	ND		10	ug/L
2-Nitrophenol	ND		10	ug/L
2,4-Dimethylphenol	ND		10	ug/L
Benzoic acid	ND		10	ug/L
bis(2-Chloroethoxy)-methane	ND		50	ug/L
2,4-Dichlorophenol	ND		10	ug/L
1,2,4-Trichlorobenzene	ND		10	ug/L
Naphthalene	ND		10	ug/L
4-Chloroaniline	ND		10	ug/L
Hexachlorobutadiene	ND		10	ug/L
4-Chloro-3-methylphenol	ND		10	ug/L
2-Methylnaphthalene	ND		10	ug/L
Hexachlorocyclopentadiene	ND		10	ug/L
2,4,6-Trichlorophenol	ND		10	ug/L
2,4,5-Trichlorophenol	ND		10	ug/L
2-Chloronaphthalene	ND		50	ug/L
2-Nitroaniline	ND		10	ug/L
Dimethyl phthalate	ND		50	ug/L
Acenaphthylene	ND		10	ug/L
2,6-Dinitrotoluene	ND		10	ug/L
3-Nitroaniline	ND		10	ug/L
Acenaphthene	ND		50	ug/L
2,4-Dinitrophenol	ND		10	ug/L
4-Nitrophenol	ND		50	ug/L
Dibenzofuran	ND		50	ug/L
2,4-Dinitrotoluene	ND		10	ug/L
Diethyl phthalate	ND		10	ug/L
4-Chlorophenyl phenyl ether	ND		10	ug/L
Fluorene	ND		10	ug/L
4-Nitroaniline	ND		10	ug/L
4,6-Dinitro-2-methylphenol	ND		50	ug/L
N-Nitrosodiphenylamine	ND		50	ug/L
4-Bromophenyl phenyl ether	ND		10	ug/L
	ND		10	ug/L

ND = Not Detected



Environmental Services (cont.)

Semivolatile Organic Compounds Method SW8270

Client Name: O'Brien & Gere Engineers, Inc.
Client ID: TF-2 (0.00,0.00,)
LAB ID: 109364-0004-SA
Matrix: GRND-H2O
Authorized: 30 DEC 94
Instrument: GC/MS-MA

Sampled: 29 DEC 94
Prepared: 30 DEC 94
Dilution: 1.0

Received: 30 DEC 94
Analyzed: 03 JAN 95

Table with 5 columns: Parameter, Result, Qualifier, RL, Units. Lists various organic compounds like Hexachlorobenzene, Pentachlorophenol, etc., with results mostly 'ND' and RL values of 10 or 20.

Table with 4 columns: Surrogate, Recovery, Acceptable Range. Lists surrogates like Nitrobenzene-d5, 2-Fluorobiphenyl, etc., with recovery percentages and acceptable ranges.

ND = Not Detected

Semivolatile Organic Compounds
Method SW8270

Client Name: O'Brien & Gere Engineers, Inc.

Client ID: TF-2A (0.00,0.00,)

LAB ID: 109364-0003-SA

Matrix: GRND-H2O

Authorized: 30 DEC 94

Instrument: GC/MS-MA

Sampled: 29 DEC 94

Prepared: 30 DEC 94

Dilution: 1.0

Received: 30 DEC 94

Analyzed: 03 JAN 95

Parameter	Result	Qualifier	RL	Units
Phenol	ND		10	ug/L
bis(2-Chloroethyl) ether	ND		10	ug/L
2-Chlorophenol	ND		10	ug/L
1,3-Dichlorobenzene	ND		10	ug/L
1,4-Dichlorobenzene	ND		10	ug/L
Benzyl alcohol	ND		10	ug/L
1,2-Dichlorobenzene	ND		10	ug/L
2-Methylphenol	ND		10	ug/L
bis(2-Chloroisopropyl) -ether	ND		10	ug/L
3/4-Methylphenol	ND		10	ug/L
N-Nitroso-di-n-propylamine	ND		10	ug/L
Hexachloroethane	ND		10	ug/L
Nitrobenzene	ND		10	ug/L
Isophorone	ND		10	ug/L
2-Nitrophenol	ND		10	ug/L
2,4-Dimethylphenol	8.7	J	10	ug/L
Benzoic acid	ND		50	ug/L
bis(2-Chloroethoxy) -methane	ND		10	ug/L
2,4-Dichlorophenol	ND		10	ug/L
1,2,4-Trichlorobenzene	ND		10	ug/L
Naphthalene	21		10	ug/L
4-Chloroaniline	ND		10	ug/L
Hexachlorobutadiene	ND		10	ug/L
4-Chloro-3-methylphenol	ND		10	ug/L
2-Methylnaphthalene	3.2	J	10	ug/L
Hexachlorocyclopentadiene	ND		10	ug/L
2,4,6-Trichlorophenol	ND		10	ug/L
2,4,5-Trichlorophenol	ND		50	ug/L
2-Chloronaphthalene	ND		10	ug/L
2-Nitroaniline	ND		50	ug/L
Dimethyl phthalate	ND		10	ug/L
Acenaphthylene	ND		10	ug/L
2,6-Dinitrotoluene	ND		10	ug/L
3-Nitroaniline	ND		50	ug/L
Acenaphthene	ND		10	ug/L
2,4-Dinitrophenol	ND		50	ug/L
4-Nitrophenol	ND		50	ug/L
Dibenzofuran	ND		10	ug/L
2,4-Dinitrotoluene	ND		10	ug/L
Diethyl phthalate	3.6	J	10	ug/L
4-Chlorophenyl phenyl ether	ND		10	ug/L
Fluorene	ND		10	ug/L
4-Nitroaniline	ND		50	ug/L
4,6-Dinitro-2-methylphenol	ND		50	ug/L
N-Nitrosodiphenylamine	ND		10	ug/L

J = Result is detected below the reporting limit or is an estimated concentration.
 ND = Not Detected



Environmental Services (cont.)

Semivolatile Organic Compounds
Method SW8270

Client Name: O'Brien & Gere Engineers, Inc.
Client ID: TF-2A (0.00,0.00,)
LAB ID: 109364-0003-SA
Matrix: GRND-H2O
Authorized: 30 DEC 94
Instrument: GC/MS-MA

Sampled: 29 DEC 94
Prepared: 30 DEC 94
Dilution: 1.0

Received: 30 DEC 94
Analyzed: 03 JAN 95

Parameter	Result	Qualifier	RL	Units
4-Bromophenyl phenyl ether	ND		10	ug/L
Hexachlorobenzene	ND		10	ug/L
Pentachlorophenol	ND		30	ug/L
Phenanthrene	ND		10	ug/L
Anthracene	ND		10	ug/L
Di-n-butyl phthalate	ND		10	ug/L
Fluoranthene	ND		10	ug/L
Pyrene	ND		10	ug/L
Butyl benzyl phthalate	ND		10	ug/L
3,3'-Dichlorobenzidine	ND		20	ug/L
Benzo(a)anthracene	ND		10	ug/L
Chrysene	ND		10	ug/L
bis(2-Ethylhexyl)-phthalate	ND		10	ug/L
Di-n-octyl phthalate	ND		10	ug/L
Benzo(b)fluoranthene	ND		10	ug/L
Benzo(k)fluoranthene	ND		10	ug/L
Benzo(a)pyrene	ND		10	ug/L
Indeno(1,2,3-c,d)pyrene	ND		10	ug/L
Dibenz(a,h)anthracene	ND		10	ug/L
Benzo(g,h,i)perylene	ND		10	ug/L
Surrogate	Recovery		Acceptable Range	
Nitrobenzene-d5	73	%	38 - 115	
2-Fluorobiphenyl	80	%	43 - 116	
Terphenyl-d14	87	%	21 - 134	
Phenol-d5	25	%	10 - 94	
2-Fluorophenol	35	%	21 - 100	
2,4,6-Tribromophenol	88	%	25 - 131	

ND = Not Detected

Semivolatile Organic Compounds
Method SW8270

Client Name: O'Brien & Gere Engineers, Inc.
 Client ID: TF-3 (0.00,0.00,)
 LAB ID: 109364-0002-SA
 Matrix: GRND-H2O
 Authorized: 30 DEC 94
 Instrument: GC/MS-MA
 Sampled: 29 DEC 94
 Prepared: 30 DEC 94
 Dilution: 1.0
 Received: 30 DEC 94
 Analyzed: 03 JAN 95

Parameter	Result	Qualifier	RL	Units
Phenol	ND		10	ug/L
bis(2-Chloroethyl) ether	ND		10	ug/L
2-Chlorophenol	ND		10	ug/L
1,3-Dichlorobenzene	ND		10	ug/L
1,4-Dichlorobenzene	ND		10	ug/L
Benzyl alcohol	ND		10	ug/L
1,2-Dichlorobenzene	ND		10	ug/L
2-Methylphenol	ND		10	ug/L
bis(2-Chloroisopropyl)-ether	ND		10	ug/L
3/4-Methylphenol	ND		10	ug/L
N-Nitroso-di-n-propylamine	ND		10	ug/L
Hexachloroethane	ND		10	ug/L
Nitrobenzene	ND		10	ug/L
Isophorone	ND		10	ug/L
2-Nitrophenol	ND		10	ug/L
2,4-Dimethylphenol	ND		10	ug/L
Benzoic acid	ND		50	ug/L
bis(2-Chloroethoxy)-methane	ND		10	ug/L
2,4-Dichlorophenol	ND		10	ug/L
1,2,4-Trichlorobenzene	ND		10	ug/L
Naphthalene	ND		10	ug/L
4-Chloroaniline	ND		10	ug/L
Hexachlorobutadiene	ND		10	ug/L
4-Chloro-3-methylphenol	ND		10	ug/L
2-Methylnaphthalene	ND		10	ug/L
Hexachlorocyclopentadiene	ND		10	ug/L
2,4,6-Trichlorophenol	ND		10	ug/L
2,4,5-Trichlorophenol	ND		50	ug/L
2-Chloronaphthalene	ND		10	ug/L
2-Nitroaniline	ND		50	ug/L
Dimethyl phthalate	ND		10	ug/L
Acenaphthylene	ND		10	ug/L
2,6-Dinitrotoluene	ND		10	ug/L
3-Nitroaniline	ND		50	ug/L
Acenaphthene	ND		10	ug/L
2,4-Dinitrophenol	ND		50	ug/L
4-Nitrophenol	ND		50	ug/L
Dibenzofuran	ND		10	ug/L
2,4-Dinitrotoluene	ND		10	ug/L
Diethyl phthalate	ND		10	ug/L
4-Chlorophenyl phenyl ether	ND		10	ug/L
Fluorene	ND		10	ug/L
4-Nitroaniline	ND		50	ug/L
4,6-Dinitro-2-methylphenol	ND		50	ug/L
N-Nitrosodiphenylamine	ND		10	ug/L
4-Bromophenyl phenyl ether	ND		10	ug/L

ND = Not Detected



Environmental
Services (cont.)

Semivolatile Organic Compounds
Method SW8270

Client Name: O'Brien & Gere Engineers, Inc.

Client ID: TF-3 (0.00,0.00,)

LAB ID: 109364-0002-SA

Matrix: GRND-H2O

Sampled: 29 DEC 94

Received: 30 DEC 94

Authorized: 30 DEC 94

Prepared: 30 DEC 94

Analyzed: 03 JAN 95

Instrument: GC/MS-MA

Dilution: 1.0

Parameter	Result	Qualifier	RL	Units
Hexachlorobenzene	ND		10	ug/L
Pentachlorophenol	ND		30	ug/L
Phenanthrene	ND		10	ug/L
Anthracene	ND		10	ug/L
Di-n-butyl phthalate	ND		10	ug/L
Fluoranthene	ND		10	ug/L
Pyrene	ND		10	ug/L
Butyl benzyl phthalate	ND		10	ug/L
3,3'-Dichlorobenzidine	ND		20	ug/L
Benzo(a)anthracene	ND		10	ug/L
Chrysene	ND		10	ug/L
bis(2-Ethylhexyl)-phthalate	ND		10	ug/L
Di-n-octyl phthalate	ND		10	ug/L
Benzo(b)fluoranthene	ND		10	ug/L
Benzo(k)fluoranthene	ND		10	ug/L
Benzo(a)pyrene	ND		10	ug/L
Indeno(1,2,3-c,d)pyrene	ND		10	ug/L
Dibenz(a,h)anthracene	ND		10	ug/L
Benzo(g,h,i)perylene	ND		10	ug/L

Surrogate	Recovery		Acceptable Range
Nitrobenzene-d5	60	%	38 - 115
2-Fluorobiphenyl	67	%	43 - 116
Terphenyl-d14	85	%	21 - 134
Phenol-d5	21	%	10 - 94
2-Fluorophenol	33	%	21 - 100
2,4,6-Tribromophenol	61	%	25 - 131

ND = Not Detected



Environmental
Services

Semivolatile Organic Compounds
Method SW8270

Client Name: O'Brien & Gere Engineers, Inc.

Client ID: TF-5 (0.00,0.00,)

LAB ID: 109394-0004-SA

Matrix: GRND-H2O

Sampled: 03 JAN 95

Received: 04 JAN 95

Authorized: 04 JAN 95

Prepared: 05 JAN 95

Analyzed: 06 JAN 95

Instrument: GC/MS

Dilution: 1.0

Parameter	Result	Qualifier	RL	Units
Phenol	ND		10	ug/L
bis(2-Chloroethyl) ether	ND		10	ug/L
2-Chlorophenol	ND		10	ug/L
1,3-Dichlorobenzene	ND		10	ug/L
1,4-Dichlorobenzene	ND		10	ug/L
Benzyl alcohol	ND		10	ug/L
1,2-Dichlorobenzene	ND		10	ug/L
2-Methylphenol	ND		10	ug/L
bis(2-Chloroisopropyl)-ether	ND		10	ug/L
3/4-Methylphenol	ND		10	ug/L
N-Nitroso-di-n-propylamine	ND		10	ug/L
Hexachloroethane	ND		10	ug/L
Nitrobenzene	ND		10	ug/L
Isophorone	ND		10	ug/L
2-Nitrophenol	ND		10	ug/L
2,4-Dimethylphenol	ND		10	ug/L
Benzoic acid	ND		50	ug/L
bis(2-Chloroethoxy)-methane	ND		10	ug/L
2,4-Dichlorophenol	ND		10	ug/L
1,2,4-Trichlorobenzene	ND		10	ug/L
Naphthalene	ND		10	ug/L
4-Chloroaniline	ND		10	ug/L
Hexachlorobutadiene	ND		10	ug/L
4-Chloro-3-methylphenol	ND		10	ug/L
2-Methylnaphthalene	ND		10	ug/L
Hexachlorocyclopentadiene	ND		10	ug/L
2,4,6-Trichlorophenol	ND		10	ug/L
2,4,5-Trichlorophenol	ND		50	ug/L
2-Chloronaphthalene	ND		10	ug/L
2-Nitroaniline	ND		50	ug/L
Dimethyl phthalate	ND		10	ug/L
Acenaphthylene	ND		10	ug/L
2,6-Dinitrotoluene	ND		10	ug/L
3-Nitroaniline	ND		50	ug/L
Acenaphthene	ND		10	ug/L
2,4-Dinitrophenol	ND		50	ug/L
4-Nitrophenol	ND		50	ug/L
Dibenzofuran	ND		10	ug/L
2,4-Dinitrotoluene	ND		10	ug/L
Diethyl phthalate	ND		10	ug/L
4-Chlorophenyl phenyl ether	ND		10	ug/L
Fluorene	ND		10	ug/L
4-Nitroaniline	ND		50	ug/L
4,6-Dinitro-2-methylphenol	ND		50	ug/L
N-Nitrosodiphenylamine	ND		10	ug/L
4-Bromophenyl phenyl ether	ND		10	ug/L

ND = Not Detected



Environmental Services (cont.)

Semivolatile Organic Compounds Method SW8270

Client Name: O'Brien & Gere Engineers, Inc.
Client ID: TF-5 (0.00,0.00,)

LAB ID: 109394-0004-SA

Matrix: GRND-H2O

Authorized: 04 JAN 95

Instrument: GC/MS

Sampled: 03 JAN 95

Prepared: 05 JAN 95

Dilution: 1.0

Received: 04 JAN 95

Analyzed: 06 JAN 95

Table with columns: Parameter, Result, Qualifier, RL, Units. Lists various organic compounds and their detection results (ND) and surrogate recovery percentages.

ND = Not Detected



Environmental
Services

Semivolatile Organic Compounds
Method SW8270

Client Name: O'Brien & Gere Engineers, Inc.
Client ID: TF-7 (0.00,0.00,)
LAB ID: 109394-0003-SA
Matrix: GRND-H2O
Authorized: 04 JAN 95
Instrument: GC/MS

Sampled: 03 JAN 95
Prepared: 05 JAN 95
Dilution: 1.0

Received: 04 JAN 95
Analyzed: 06 JAN 95

Parameter	Result	Qualifier	RL	Units
Phenol	ND		10	ug/L
bis(2-Chloroethyl) ether	ND		10	ug/L
2-Chlorophenol	ND		10	ug/L
1,3-Dichlorobenzene	ND		10	ug/L
1,4-Dichlorobenzene	ND		10	ug/L
Benzyl alcohol	ND		10	ug/L
1,2-Dichlorobenzene	ND		10	ug/L
2-Methylphenol	ND		10	ug/L
bis(2-Chloroisopropyl)-ether	ND		10	ug/L
3/4-Methylphenol	ND		10	ug/L
N-Nitroso-di-n-propylamine	ND		10	ug/L
Hexachloroethane	ND		10	ug/L
Nitrobenzene	ND		10	ug/L
Isophorone	ND		10	ug/L
2-Nitrophenol	ND		10	ug/L
2,4-Dimethylphenol	ND		10	ug/L
Benzoic acid	ND		50	ug/L
bis(2-Chloroethoxy)-methane	ND		10	ug/L
2,4-Dichlorophenol	ND		10	ug/L
1,2,4-Trichlorobenzene	ND		10	ug/L
Naphthalene	ND		10	ug/L
4-Chloroaniline	ND		10	ug/L
Hexachlorobutadiene	ND		10	ug/L
4-Chloro-3-methylphenol	ND		10	ug/L
2-Methylnaphthalene	ND		10	ug/L
Hexachlorocyclopentadiene	ND		10	ug/L
2,4,6-Trichlorophenol	ND		10	ug/L
2,4,5-Trichlorophenol	ND		50	ug/L
2-Chloronaphthalene	ND		10	ug/L
2-Nitroaniline	ND		50	ug/L
Dimethyl phthalate	ND		10	ug/L
Acenaphthylene	ND		10	ug/L
2,6-Dinitrotoluene	ND		10	ug/L
3-Nitroaniline	ND		50	ug/L
Acenaphthene	ND		10	ug/L
2,4-Dinitrophenol	ND		50	ug/L
4-Nitrophenol	ND		50	ug/L
Dibenzofuran	ND		10	ug/L
2,4-Dinitrotoluene	ND		10	ug/L
Diethyl phthalate	ND		10	ug/L
4-Chlorophenyl phenyl ether	ND		10	ug/L
Fluorene	ND		10	ug/L
4-Nitroaniline	ND		50	ug/L
4,6-Dinitro-2-methylphenol	ND		50	ug/L
N-Nitrosodiphenylamine	ND		10	ug/L
4-Bromophenyl phenyl ether	ND		10	ug/L

ND = Not Detected

Semivolatile Organic Compounds
Method SW8270

Client Name: O'Brien & Gere Engineers, Inc.
Client ID: TF-7 (0.00,0.00,)

LAB ID: 109394-0003-SA

Matrix: GRND-H2O

Authorized: 04 JAN 95

Instrument: GC/MS

Sampled: 03 JAN 95

Prepared: 05 JAN 95

Dilution: 1.0

Received: 04 JAN 95

Analyzed: 06 JAN 95

Parameter	Result	Qualifier	RL	Units
Hexachlorobenzene	ND		10	ug/L
Pentachlorophenol	ND		30	ug/L
Phenanthrene	ND		10	ug/L
Anthracene	ND		10	ug/L
Di-n-butyl phthalate	ND		10	ug/L
Fluoranthene	ND		10	ug/L
Pyrene	ND		10	ug/L
Butyl benzyl phthalate	ND		10	ug/L
3,3'-Dichlorobenzidine	ND		10	ug/L
Benzo(a)anthracene	ND		20	ug/L
Chrysene	ND		10	ug/L
bis(2-Ethylhexyl)-phthalate	ND		10	ug/L
Di-n-octyl phthalate	ND		10	ug/L
Benzo(b)fluoranthene	ND		10	ug/L
Benzo(k)fluoranthene	ND		10	ug/L
Benzo(a)pyrene	ND		10	ug/L
Indeno(1,2,3-c,d)pyrene	ND		10	ug/L
Dibenz(a,h)anthracene	ND		10	ug/L
Benzo(g,h,i)perylene	ND		10	ug/L
Surrogate	Recovery		Acceptable Range	
Nitrobenzene-d5	72	%	38 - 115	
2-Fluorobiphenyl	77	%	43 - 116	
Terphenyl-d14	98	%	21 - 134	
Phenol-d5	38	%	10 - 94	
2-Fluorophenol	52	%	21 - 100	
2,4,6-Tribromophenol	102	%	25 - 131	

ND = Not Detected



Environmental
Services

Semivolatile Organic Compounds
Method SW8270

Client Name: O'Brien & Gere Engineers, Inc.
Client ID: TF-8 (0.00,0.00,)
LAB ID: 109394-0002-SA
Matrix: GRND-H2O
Authorized: 04 JAN 95
Instrument: GC/MS

Sampled: 03 JAN 95
Prepared: 05 JAN 95
Dilution: 1.0

Received: 04 JAN 95
Analyzed: 06 JAN 95

Parameter	Result	Qualifier	RL	Units
Phenol	ND		10	ug/L
bis(2-Chloroethyl) ether	ND		10	ug/L
2-Chlorophenol	ND		10	ug/L
1,3-Dichlorobenzene	ND		10	ug/L
1,4-Dichlorobenzene	ND		10	ug/L
Benzyl alcohol	ND		10	ug/L
1,2-Dichlorobenzene	ND		10	ug/L
2-Methylphenol	ND		10	ug/L
bis(2-Chloroisopropyl)-ether	ND		10	ug/L
3/4-Methylphenol	ND		10	ug/L
N-Nitroso-di-n-propylamine	ND		10	ug/L
Hexachloroethane	ND		10	ug/L
Nitrobenzene	ND		10	ug/L
Isophorone	ND		10	ug/L
2-Nitrophenol	ND		10	ug/L
2,4-Dimethylphenol	ND		10	ug/L
Benzoic acid	ND		50	ug/L
bis(2-Chloroethoxy)-methane	ND		10	ug/L
2,4-Dichlorophenol	ND		10	ug/L
1,2,4-Trichlorobenzene	ND		10	ug/L
Naphthalene	ND		10	ug/L
4-Chloroaniline	ND		10	ug/L
Hexachlorobutadiene	ND		10	ug/L
4-Chloro-3-methylphenol	ND		10	ug/L
2-Methylnaphthalene	ND		10	ug/L
Hexachlorocyclopentadiene	ND		10	ug/L
2,4,6-Trichlorophenol	ND		10	ug/L
2,4,5-Trichlorophenol	ND		50	ug/L
2-Chloronaphthalene	ND		10	ug/L
2-Nitroaniline	ND		50	ug/L
Dimethyl phthalate	ND		10	ug/L
Acenaphthylene	ND		10	ug/L
2,6-Dinitrotoluene	ND		10	ug/L
3-Nitroaniline	ND		50	ug/L
Acenaphthene	ND		10	ug/L
2,4-Dinitrophenol	ND		50	ug/L
4-Nitrophenol	ND		50	ug/L
Dibenzofuran	ND		10	ug/L
2,4-Dinitrotoluene	ND		10	ug/L
Diethyl phthalate	ND		10	ug/L
4-Chlorophenyl phenyl ether	ND		10	ug/L
Fluorene	ND		10	ug/L
4-Nitroaniline	ND		50	ug/L
4,6-Dinitro-2-methylphenol	ND		50	ug/L
N-Nitrosodiphenylamine	ND		10	ug/L
4-Bromophenyl phenyl ether	ND		10	ug/L

ND = Not Detected



Environmental Services (cont.)

Semivolatile Organic Compounds Method SW8270

Client Name: O'Brien & Gere Engineers, Inc.
Client ID: TF-8 (0.00,0.00,)
LAB ID: 109394-0002-SA
Matrix: GRND-H2O
Authorized: 04 JAN 95
Instrument: GC/MS

Sampled: 03 JAN 95
Prepared: 05 JAN 95
Dilution: 1.0

Received: 04 JAN 95
Analyzed: 06 JAN 95

Table with columns: Parameter, Result, Qualifier, RL, Units. Lists various organic compounds and their detection results (ND) and recovery percentages.

ND = Not Detected



Environmental
Services

Semivolatle Organic Compounds
Method SW8270

Client Name: O'Brien & Gere Engineers, Inc.
Client ID: TF-11 (0.00,0.00,)
LAB ID: 109394-0001-SA
Matrix: GRND-H2O
Authorized: 04 JAN 95
Instrument: GC/MS-ME

Sampled: 03 JAN 95
Prepared: 05 JAN 95
Dilution: 1.0

Received: 04 JAN 95
Analyzed: 06 JAN 95

Parameter	Result	Qualifier	RL	Units
Phenol	ND		10	ug/L
bis(2-Chloroethyl) ether	ND		10	ug/L
2-Chlorophenol	ND		10	ug/L
1,3-Dichlorobenzene	ND		10	ug/L
1,4-Dichlorobenzene	ND		10	ug/L
Benzyl alcohol	ND		10	ug/L
1,2-Dichlorobenzene	ND		10	ug/L
2-Methylphenol	ND		10	ug/L
bis(2-Chloroisopropyl)-ether	ND		10	ug/L
3/4-Methylphenol	ND		10	ug/L
N-Nitroso-di-n-propylamine	ND		10	ug/L
Hexachloroethane	ND		10	ug/L
Nitrobenzene	ND		10	ug/L
Isophorone	ND		10	ug/L
2-Nitrophenol	ND		10	ug/L
2,4-Dimethylphenol	ND		10	ug/L
Benzoic acid	ND		50	ug/L
bis(2-Chloroethoxy)-methane	ND		10	ug/L
2,4-Dichlorophenol	ND		10	ug/L
1,2,4-Trichlorobenzene	ND		10	ug/L
Naphthalene	4.6	J	10	ug/L
4-Chloroaniline	ND		10	ug/L
Hexachlorobutadiene	ND		10	ug/L
4-Chloro-3-methylphenol	ND		10	ug/L
2-Methylnaphthalene	ND		10	ug/L
Hexachlorocyclopentadiene	ND		10	ug/L
2,4,6-Trichlorophenol	ND		10	ug/L
2,4,5-Trichlorophenol	ND		50	ug/L
2-Chloronaphthalene	ND		10	ug/L
2-Nitroaniline	ND		50	ug/L
Dimethyl phthalate	ND		10	ug/L
Acenaphthylene	ND		10	ug/L
2,6-Dinitrotoluene	ND		10	ug/L
3-Nitroaniline	ND		50	ug/L
Acenaphthene	ND		10	ug/L
2,4-Dinitrophenol	ND		50	ug/L
4-Nitrophenol	ND		50	ug/L
Dibenzofuran	ND		10	ug/L
2,4-Dinitrotoluene	ND		10	ug/L
Diethyl phthalate	ND		10	ug/L
4-Chlorophenyl phenyl ether	ND		10	ug/L
Fluorene	ND		10	ug/L
4-Nitroaniline	ND		50	ug/L
4,6-Dinitro-2-methylphenol	ND		50	ug/L
N-Nitrosodiphenylamine	ND		10	ug/L

J = Result is detected below the reporting limit or is an estimated concentration.
ND = Not Detected

Semivolatile Organic Compounds
 Method SW8270

Client Name: O'Brien & Gere Engineers, Inc.

Client ID: TF-11 (0.00,0.00,)

LAB ID: 109394-0001-SA

Matrix: GRND-H2O

Sampled: 03 JAN 95

Received: 04 JAN 95

Authorized: 04 JAN 95

Prepared: 05 JAN 95

Analyzed: 06 JAN 95

Instrument: GC/MS-ME

Dilution: 1.0

Parameter	Result	Qualifier	RL	Units
4-Bromophenyl phenyl ether	ND		10	ug/L
Hexachlorobenzene	ND		10	ug/L
Pentachlorophenol	ND		30	ug/L
Phenanthrene	ND		10	ug/L
Anthracene	ND		10	ug/L
Di-n-butyl phthalate	ND		10	ug/L
Fluoranthene	ND		10	ug/L
Pyrene	ND		10	ug/L
Butyl benzyl phthalate	ND		10	ug/L
3,3'-Dichlorobenzidine	ND		20	ug/L
Benzo(a)anthracene	ND		10	ug/L
Chrysene	ND		10	ug/L
bis(2-Ethylhexyl)-phthalate	ND		10	ug/L
Di-n-octyl phthalate	ND		10	ug/L
Benzo(b)fluoranthene	ND		10	ug/L
Benzo(k)fluoranthene	ND		10	ug/L
Benzo(a)pyrene	ND		10	ug/L
Indeno(1,2,3-c,d)pyrene	ND		10	ug/L
Dibenz(a,h)anthracene	ND		10	ug/L
Benzo(g,h,i)perylene	ND		10	ug/L

Surrogate	Recovery		Acceptable Range
Nitrobenzene-d5	92	%	38 - 115
2-Fluorobiphenyl	88	%	43 - 116
Terphenyl-d14	95	%	21 - 134
Phenol-d5	46	%	10 - 94
2-Fluorophenol	62	%	21 - 100
2,4,6-Tribromophenol	103	%	25 - 131

ND = Not Detected