

LOAN DOCUMENT

PHOTOGRAPH THIS SHEET

①

DTIC ACCESSION NUMBER

LEVEL

INVENTORY

Bioventing Pilot Test Results Rpt. for ...
DOCUMENT IDENTIFICATION
Mar 96

DISTRIBUTION STATEMENT A
Approved for Public Release
Distribution Unlimited

DISTRIBUTION STATEMENT

ACCESSION FOR	
NTIS	GRAM <input checked="" type="checkbox"/>
DTIC	TRAC <input type="checkbox"/>
UNANNOUNCED	<input type="checkbox"/>
JUSTIFICATION	
BY	
DISTRIBUTION/	
AVAILABILITY CODES	
DISTRIBUTION	AVAILABILITY AND/OR SPECIAL
A-1	

DISTRIBUTION STAMP

DATE ACCESSIONED

DATE RETURNED

REGISTERED OR CERTIFIED NUMBER

DTIC QUALITY IMPROVED 4
20010117 016

DATE RECEIVED IN DTIC

REGISTERED OR CERTIFIED NUMBER

PHOTOGRAPH THIS SHEET AND RETURN TO DTIC-FDAC

H
A
N
D
L
E

W
I
T
H

C
A
R
E

Bioventing Pilot Test Results Report For Capehart Gas Station



**McClellan Air Force Base,
California**

Prepared for

**Air Force Center For Environmental Excellence
Technology Transfer Division
Brooks Air Force Base
San Antonio, Texas**

and

**Environmental Management
McClellan Air Force Base, California**

March 1996

Prepared by

PARSONS ENGINEERING SCIENCE, INC.
PLANNING • DESIGN • CONSTRUCTION MANAGEMENT
1301 MARINA VILLAGE PARKWAY, ALAMEDA, CA 94501 • 510/769-0100
OFFICES IN OTHER PRINCIPAL CITIES

AQM01-04-0641

DEFENSE TECHNICAL INFORMATION CENTER REQUEST FOR SCIENTIFIC AND TECHNICAL REPORTS

Title AFCEE Collection

1. Report Availability (Please check one box)

- This report is available. Complete sections 2a - 2f.
- This report is not available. Complete section 3.

2a. Number of Copies Forwarded

1 each

2b. Forwarding Date

July/2000

2c. Distribution Statement (Please check ONE box)

DoD Directive 5230.24, "Distribution Statements on Technical Documents," 18 Mar 87, contains seven distribution statements, as described briefly below. Technical documents MUST be assigned a distribution statement.

- DISTRIBUTION STATEMENT A: Approved for public release. Distribution is unlimited.
- DISTRIBUTION STATEMENT B: Distribution authorized to U.S. Government Agencies only.
- DISTRIBUTION STATEMENT C: Distribution authorized to U.S. Government Agencies and their contractors.
- DISTRIBUTION STATEMENT D: Distribution authorized to U.S. Department of Defense (DoD) and U.S. DoD contractors only.
- DISTRIBUTION STATEMENT E: Distribution authorized to U.S. Department of Defense (DoD) components only.
- DISTRIBUTION STATEMENT F: Further dissemination only as directed by the controlling DoD office indicated below or by higher authority.
- DISTRIBUTION STATEMENT X: Distribution authorized to U.S. Government agencies and private individuals or enterprises eligible to obtain export-controlled technical data in accordance with DoD Directive 5230.25, Withholding of Unclassified Technical Data from Public Disclosure, 6 Nov 84.

2d. Reason For the Above Distribution Statement (in accordance with DoD Directive 5230.24)

2e. Controlling Office

HQ AFCEE

2f. Date of Distribution Statement Determination

15 Nov 2000

3. This report is NOT forwarded for the following reasons. (Please check appropriate box)

- It was previously forwarded to DTIC on _____ (date) and the AD number is _____
- It will be published at a later date. Enter approximate date if known. _____
- In accordance with the provisions of DoD Directive 3200.12, the requested document is not supplied because:

Print or Type Name

Laura Peña

Signature

Laura Peña

Telephone

210-536-1431

(For DTIC Use Only)

AQ Number M01-04-0641

**BIOVENTING PILOT TEST RESULTS REPORT FOR
CAPEHART GAS STATION
MCCLELLAN AIR FORCE BASE, CALIFORNIA**

Prepared for

**Air Force Center For Environmental Excellence
Technology Transfer Division
Brooks Air Force Base
San Antonio, Texas**

and

**Environmental Management
McClellan Air Force Base, California**

March 1996

Prepared by

**PARSONS ENGINEERING SCIENCE, INC.
PLANNING • DESIGN • CONSTRUCTION MANAGEMENT
1301 MARINA VILLAGE PARKWAY, ALAMEDA, CA 94501 • 510/769-0100
OFFICES IN OTHER PRINCIPAL CITIES**

TABLE OF CONTENTS

	<u>Page</u>
SECTION 1 PILOT TEST DESIGN AND CONSTRUCTION	1-1
1.1 Pilot Test Activities.....	1-1
1.2 Drilling Activities And Well Installation	1-2
1.2.1 Vent Well Installation	1-2
1.2.2 Soil Vapor Monitoring Well Installation	1-8
1.3 Soil Profile.....	1-10
1.4 Soil Vapor Extraction System	1-10
1.5 Air Injection Bioventing System.....	1-14
SECTION 2 SOIL AND SOIL GAS SAMPLING.....	2-1
2.1 Soil Sampling	2-1
2.2 Soil Gas Sampling.....	2-2
2.2.1 Downhole Sampling.....	2-2
2.2.2 Soil Vapor Monitoring Well Sampling.....	2-2
2.2.3 Soil Vapor Extraction System Sampling	2-2
2.3 Sampling Results And Subsurface Contamination	2-5
2.4 QA/QC Results.....	2-7
2.5 Exceptions To Protocol Document Procedures.....	2-7
SECTION 3 PILOT TEST RESULTS AND RECOMMENDATIONS	3-1
3.1 Soil Gas Chemistry.....	3-1
3.2 Air Permeability	3-1
3.3 Oxygen Influence	3-5
3.4 <i>In Situ</i> Respiration Rates and Biodegradation Rates.....	3-5
3.5 Mass Removal	3-13
3.6 Recommendations	3-16
SECTION 4 REFERENCES	4-1
APPENDIX A Geologic Boring Logs	
APPENDIX B O&M Manual And Data Collection Sheet	
APPENDIX C Chain Of Custody Forms	
APPENDIX D Biodegradation Rate Calculations	

LIST OF FIGURES

<u>Figure</u>	<u>Page</u>
1.1 As-Built Vent Well and Soil Vapor Monitoring Well Locations.....	1-3
1.2 Vent Well Construction Diagram (VW-1)	1-6
1.3 Soil Vapor Monitoring Well Construction Diagram (CP-11)	1-9
1.4 Geologic Cross-Section A-A'	1-11
1.5 Process Flow and Instrumentation Diagram, Soil Vapor Extraction Into Carbon	1-12
1.6 Process Flow and Instrumentation Diagram, Soil Vapor Extraction With Internal Combustion Engine	1-13
1.7 Process Flow and Instrumentation Diagram, Air Injection Blower System.....	1-15
3.1 Air Permeability During SVE Operations (April 1995), Steady-State Calculation Method	3-3
3.2 Air Permeability During Air Injection Operations (July 1995), Steady-State Calculation Method	3-4
3.3 Respiration Test at VW-1	3-7
3.4 Respiration Test at CP-1	3-8
3.5 Respiration Test at CP-3	3-9
3.6 Respiration Test at CP-4.....	3-10
3.7 Respiration Test at CP-5.....	3-11
3.8 Influent TVH-g and Extraction Flow Rate vs. Time and Total SCF Treated	3-14
3.9 Mass Removal Rates vs. Time and Total SCF Treated.....	3-15

LIST OF TABLES

<u>Table</u>	<u>Page</u>
1.1 Borehole and Soil Sample Summary Data	1-4
1.2 Downhole Soil Gas Sample Summary Data.....	1-5
1.3 Well Construction Data	1-7
2.1 Initial Soil and Soil Gas Analytical Results	2-3
2.2 One-Year Soil and Soil Gas Analytical Results	2-4
3.1 Initial Soil Gas Conditions	3-2
3.2 Influence of Soil Vapor Extraction and Air Injection on Oxygen Levels	3-6
3.3 Pilot Test Data Summary.....	3-12

SECTION 1

PILOT TEST DESIGN AND CONSTRUCTION

An initial bioventing pilot test was completed at the Capehart Gas Station, McClellan Air Force Base, California. The purpose of this Bioventing Pilot Test Results Report is to describe the results of the pilot test and make specific recommendations for future bioventing operations at the site. The site history, known contamination distributions and concentrations, and geologic/hydrogeologic profile are documented in the Bioventing Pilot Test Work Plan (Engineering-Science, 1994a).

1.1 PILOT TEST ACTIVITIES

The bioventing pilot test included installing one vent well (VW) and one soil vapor monitoring well (SVMW) to supplement existing wells, conducting an initial *in situ* respiration (ISR) test, operating a soil vapor extraction (SVE) system, operating an air injection bioventing system, and conducting a follow-up ISR test after one year of operation. Soil and soil-gas sampling was conducted both before and after the pilot test to evaluate the effectiveness of the system. A chronological summary of site operations is shown below.

Activity	Date(s)
Installation of one VW (VW-1) and initial soil sampling	5/18/94 - 5/20/94
Initial soil-gas sampling and ISR test	5/25/94 - 5/27/94
SVE operations using granular activated carbon	6/13/94 - 6/16/94
SVE operations using internal combustion engine	11/1/94 - 6/26/95
Air injection bioventing system operations	6/27/95 - (ongoing)
One-year soil-gas sampling and ISR test	11/13/95 - 11/16/95
Drilling of four boreholes (CP-8 through CP-11), installation of one SVMW (CP-11), and one-year soil sampling	11/27/95 - 11/29/95

1.2 DRILLING ACTIVITIES AND WELL INSTALLATION

1.2.1 Vent Well Installation

One vent well (VW) was installed in a location where soils exhibited a noticeable fuel odor following procedures described in the protocol document (Hinchee et al., 1992). Borehole drilling services were provided by Beylik Drilling, Inc. of Sacramento, California. Soil sampling and well installation were directed onsite by Mr. Henry Pietropaoli of the Parsons Engineering Science, Inc. (Parsons ES) office in Alameda, California.

The air injection VW (VW-1) was installed near soil vapor monitoring well CP-4 on the northwest side of the pump island (Figure 1.1). The VW was constructed using 4-inch inside diameter (ID), Schedule 40 PVC casing and slotted screen (0.040-inch slot size). The screen was set between 10 feet and 105 feet below ground surface (bgs). The annular space adjacent to the screen was filled with 6-9 sieve size silica sand (filter pack material) from one foot above the top of the screen to one foot below the bottom of the screen. A small amount of 100 mesh silica sand was added to the top of this interval to inhibit penetration of the overlying bentonite seal material into the filter pack.

Soil samples from split-spoon and/or continuous soil samplers were collected for field organic vapor analysis (OVA) of soil sample headspace to determine the appropriate VW screened interval and total depth. Both a total hydrocarbon vapor analyzer (THVA) and a photoionization detector (PID) were used. Field OVA readings were also used to screen field samples for laboratory analysis. Borehole, field OVA, and soil sample data collected during activities conducted by Parsons ES are summarized in Table 1.1. These results and the laboratory analytical results are discussed in Section 2.

Downhole soil gas samples were also collected during drilling of VW-1. Samples were collected at five foot intervals using a soil-gas probe advanced ahead of the drill auger approximately 1 to 2 feet into the undisturbed soil. Downhole soil-gas results are shown in Table 1.2. These results and the laboratory analytical results are discussed in Section 2.

To prevent preferential air movement from the surface during pilot testing, 3-foot thick annular bentonite and bentonite/cement grout seals were emplaced on top of the filter pack. Two additional bentonite seals were installed to allow for isolation of the screened interval between 40 and 80 feet bgs, where the soil lithology indicated primarily low permeability clays. The two additional 5-foot thick bentonite intervals were placed between the filter pack, from 45 to 50 feet bgs and from 75 to 80 feet bgs (Figure 1.2 and Table 1.3). The upper 2 feet of annular space was left vacant for ease of connecting subsurface piping for pilot testing.

The upper 2 feet of well casing was completed with a 4-inch diameter Schedule 40 PVC tee and a 4-inch PVC cap for sampling access. The surface completion consisted of a heavy-duty, 16-inch diameter, water-tight, traffic-proof, cast-iron well box (securable with hexbolts) emplaced within a 2.5-foot diameter concrete collar.

FIGURE 1.1

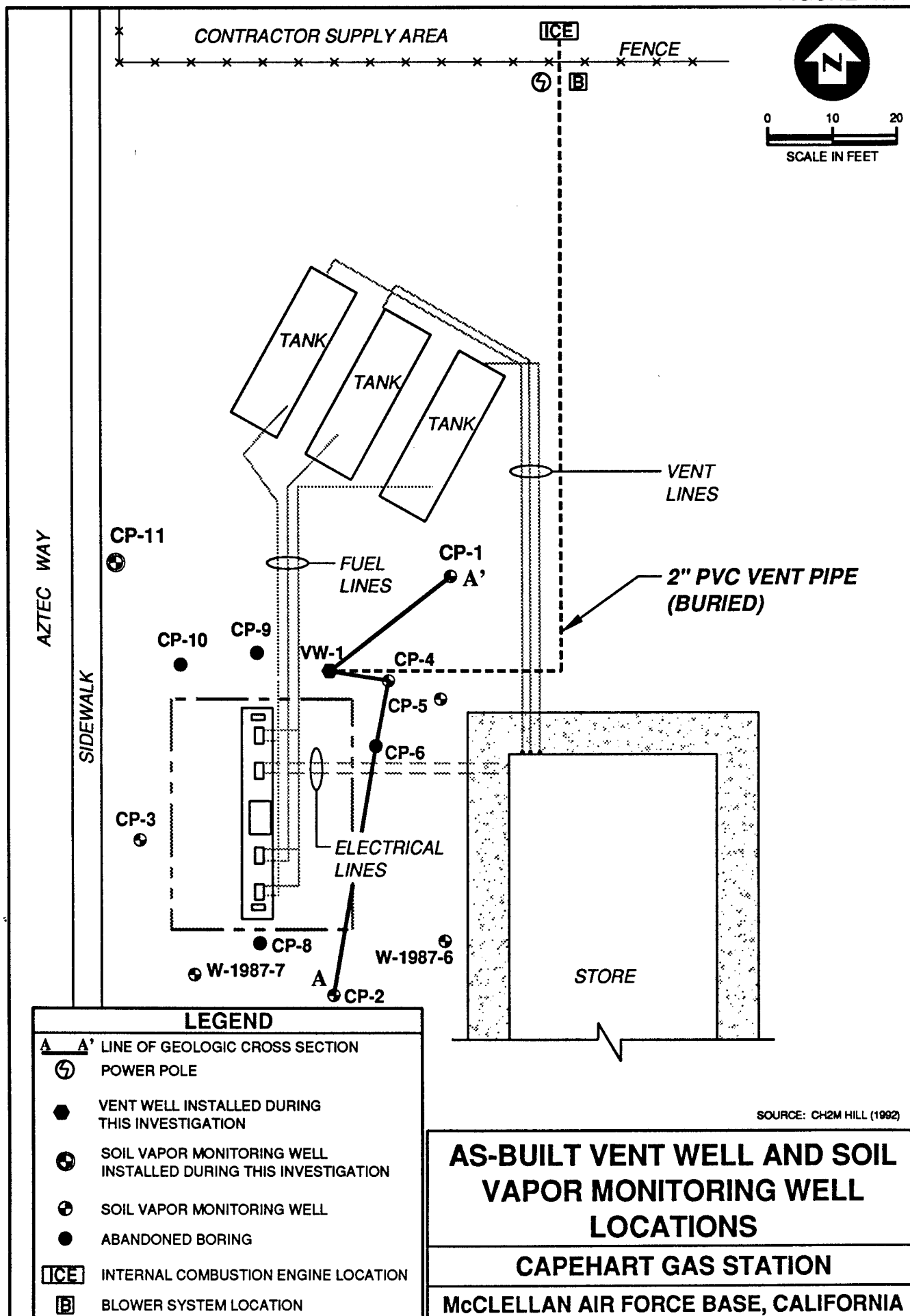

LEGEND	
A-A'	LINE OF GEOLOGIC CROSS SECTION
⊕	POWER POLE
●	VENT WELL INSTALLED DURING THIS INVESTIGATION
⊕	SOIL VAPOR MONITORING WELL INSTALLED DURING THIS INVESTIGATION
⊕	SOIL VAPOR MONITORING WELL
●	ABANDONED BORING
ICE	INTERNAL COMBUSTION ENGINE LOCATION
B	BLOWER SYSTEM LOCATION

SOURCE: CH2M HILL (1992)

AS-BUILT VENT WELL AND SOIL VAPOR MONITORING WELL LOCATIONS

CAPEHART GAS STATION

McCLELLAN AIR FORCE BASE, CALIFORNIA

TABLE 1.1
BOREHOLE AND SOIL SAMPLE SUMMARY DATA
Capehart Gas Station
McClellan AFB, California

BOREHOLE ID #	BOREHOLE TOTAL DEPTH (ft. bgs)	SOIL SAMPLE INTERVAL (ft. bgs)	TVH/PID HEADSPACE READINGS (ppmv)	SOIL SAMPLE ID #	START DATE	COMPLETION DATE	COMPLETION DESIGNATION
1	106.5	5.0 - 6.5	>10,000/2,680		5/18/94	5/20/94	VW-1
		10.0 - 11.5	650/458				
		15.0 - 16.5	NR/NR				
		20.0 - 21.5	440/268	CAP-VW1-21.5			
		25.0 - 26.5	200/130				
		30.0 - 31.5	186/8.8				
		35.0 - 36.5	25/4.7				
		40.0 - 41.5	85/2.8				
		45.0 - 46.5	20/18				
		60.0 - 61.5	40/26				
		65.0 - 66.5	69/57				
		68.0 - 69.5	40/17				
		75.0 - 76.5	78/18				
		80.0 - 81.5	40/18				
		85.0 - 86.5	70/22				
		90.0 - 91.5	100/42				
95.0 - 96.5	6.0/2.0	CAP-VW1-96.5					
100.0 - 101.5	150/47	CAP-VW1-101					
CP-8	25.5	0.0 - 4.0	18/4.7		11/27/95	11/28/95	abandoned
		4.0 - 7.5	8/3.0				
		9.5 - 11.5	20/12.5				
		15.0 - 17.0	60/10.5				
		21.0 - 23.0	25/8.5				
		23.5 - 25.5	12/0.9	CAP-CP8-25.5			
CP-9	9.5	0.5 - 4.0	NR/NR		11/28/95	11/28/95	abandoned
		4.0 - 7.0	250/512				
		7.5 - 9.5	1500/4276	CAP-CP9-9.5			
CP-10	34.0	0.5 - 4.0	20/1.5		11/28/95	11/28/95	abandoned
		4.0 - 7.0	75/211				
		8.0 - 10.0	700/2629				
		12.0 - 14.0	2000/3791	CAP-CP10-14			
		15.0 - 17.0	700/1859				
		17.0 - 19.0	1800/4647				
		22.0 - 24.0	28/6.0				
		26.0 - 28.0	10/6.0				
		32.0 - 34.0	4/6.1	CAP-CP10-34			
CP-11	29.0	0.6 - 4.0	10/0.5		11/29/95	11/29/95	CP-11
		4.0 - 7.5	27/1.2				
		8.0 - 10.0	5/7.3				
		14.0 - 16.0	1200/2901				
		16.0 - 17.5	139/40	CAP-CP11-17.5			
		21.0 - 24.0	28/14.8				
		24.5 - 26.5	30/4.4	CAP-CP11-26.5			

TVH = Total volatile hydrocarbons
 PID = Photoionization Detector

ppmv = parts per million by volume
 NR = Not Recorded

02/23/96
 capir.xls

TABLE 1.2
DOWNHOLE SOIL GAS SAMPLE SUMMARY DATA
Capehart Gas Station
McClellan AFB, California

LOCATION	BOREHOLE TOTAL DEPTH (ft. bgs)	SOIL GAS SAMPLE DEPTH (ft. bgs)	OXYGEN (%)	CARBON DIOXIDE (%)	TVH (ppmv)	SOIL GAS SAMPLE ID#
VW-1	106.5	7.5	0.5	15.3	>10,000	
		12.5	NS	NS	NS	
		17.5	2.0	14.0	>10,000	
		22.5	NS	NS	NS	
		27.5	0.5	16.5	>10,000	CAP-VW1-26.5
		32.5	NS	NS	NS	
		37.5	16.2	6.5	>10,000	
		42.5	6.5	13.5	>10,000	
		49.0	NS	NS	NS	
		59.0	1.0	13.0	>10,000	
		67.5	NS	NS	NS	
		77.5	NS	NS	NS	
		89.5	19.5	0.5	1,400	
97.5	19.0	0.6	9,000	CAP-VW1-97.5		
CP-8	25.5	8.0	19.5	1.5	65	
		15.0	NS	NS	NS	
		20.0	19.5	0.7	22	
		24.0	NS	NS	NS	
		28.0	NS	NS	NS	
CP-9	9.5	8.0	0.0	5.9	1,600	
		10.5	0.0	5.0	4,500	CAP-CP9-10.5
CP-10	34.0	8.0	NS	NS	NS	
		15.0	0.5	5.8	7,400	CAP-CP10-15
		25.0	8.5	0.8	1,000	
		30.0	15.0	0.7	120	CAP-CP10-30
CP-11	29.0	10.5	1.0	8.8	4,600	CAP-CP11-10.5
		20.5	1.9	4.9	1,500	
		28.0	14.5	1.1	3,400	CAP-CP11-28

TVH = Total volatile hydrocarbons
 PID = Photoionization Detector

ppmv = parts per million by volume
 NS = Not Sampled; soils too tight

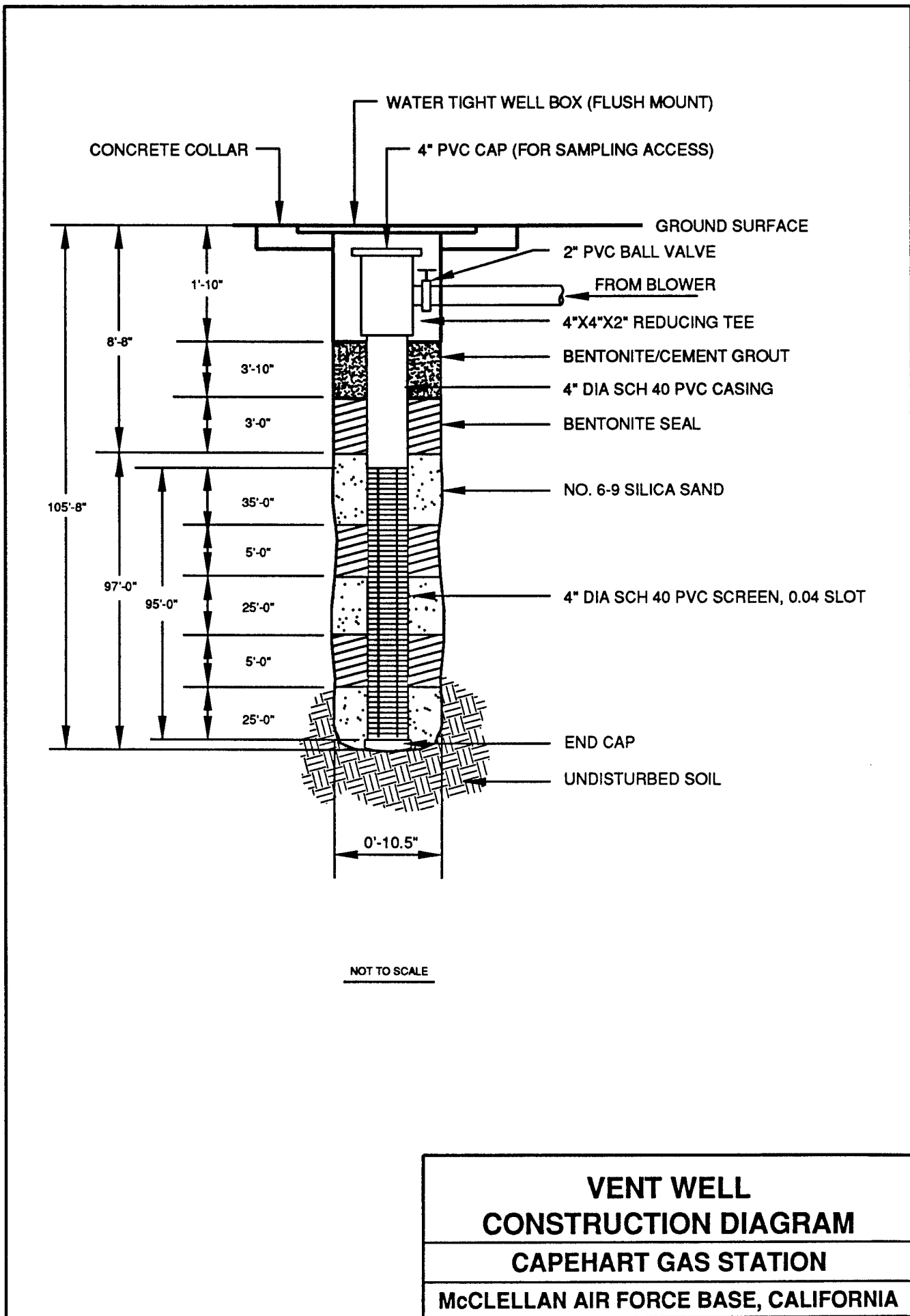

**VENT WELL
CONSTRUCTION DIAGRAM
CAPEHART GAS STATION
McCLELLAN AIR FORCE BASE, CALIFORNIA**

TABLE 1.3
WELL CONSTRUCTION DATA
Capehart Gas Station
McClellan AFB, California

WELL ID #	BOREHOLE TOTAL DEPTH (ft.bgs)	VW SCREEN INTERVAL (ft.bgs)	FILTER PACK INTERVAL(s) (ft.bgs)	BENTONITE INTERVAL(s) (ft.bgs)	GROUT INTERVAL(s) (ft.bgs)
VW-1	105.7	10.0 - 105.0	8.7 - 45.0	5.7 - 8.7	1.8 - 5.7
			50.0 - 75.0	45.0 - 50.0	
			80.0 - 105.7	75.0 - 80.0	
CP-11	29.0	13.0 - 15.0	10.5 - 15.5	0.5 - 10.5	-
				15.5 - 29.0	

VW-1 was connected to the blower unit by 2-inch ID Schedule 40 PVC pipe buried in a trench. The trench, approximately 135 feet long, 8 inches wide, and 1 foot deep, was excavated from the blower location to VW-1. The horizontal pipe in the trench was elbowed below ground at the designated blower location and the top of the vertical PVC pipe was cut to approximately two feet above ground surface. The above ground PVC pipe was connected directly to the portable blower unit for the short-term SVE test using granular activated carbon, to the internal combustion engine (ICE) for the long-term SVE operations, and finally to the fixed blower unit for the ongoing air injection bioventing operations.

1.2.2 Soil Vapor Monitoring Well Installation

One additional SVMW, designated CP-11, was installed during confirmatory soil sampling in November 1995. The 7 other SVMWs at the site (CP-1, CP-2, CP-3, CP-4, CP-5, W1987-6 and W1987-7) were installed during previous site investigations (CH2M Hill 1992). The SVMW (CP-11) was installed west of the fuel supply lines which run between the USTs and the pump island (Figure 1.1). Three other boreholes, designated CP-8, CP-9, and CP-10, also were drilled during confirmatory sampling but were not converted to SVMWs. The purpose of the additional SVMW was to allow for long-term monitoring of an area of the site that was not previously investigated, and where contaminated soils were identified during confirmatory soil sampling.

Confirmatory soil sampling was conducted using the Geoprobe[®] system. The Geoprobe[®] system is a hydraulically powered percussion/probing machine used to advance sampling tools through unconsolidated soils. Soil samples were collected using a probe-drive sampler. The probe-drive sampler served as both the driving point and the sample collection device. To collect a soil sample, the sampler was pushed or driven to the desired sampling depth, the drive point was retracted, opening the sampling barrel, and the sampler was subsequently pushed into the undisturbed soils. The probe rods were then retracted, bringing the sampling device to the surface. This system provides for the rapid collection of soil and soil gas samples at shallow depths while minimizing the generation of investigation-derived waste materials. Soil sampling and SVMW installation was directed onsite by Mr. Henry Pietropaoli and Mr. Mark Vessely of the Parsons ES offices in Alameda, California, and Denver, Colorado, respectively.

The SVMW was constructed of 0.75-inch OD/0.5-inch ID Schedule 40 PVC casing and 2 feet of factory-slotted, 0.01-inch well screen. SVMW casing sections were flush-threaded and joints were not glued. The screen was set between 13 and 15 feet bgs. The annular space adjacent to the screen was filled with #3 sieve size silica sand (filter pack material). A 10-foot thick bentonite seal was emplaced on top of the filter pack. The surface completion consisted of a 6-inch diameter, water-tight, traffic-proof, cast-iron well box (securable with hexbolts). The surface was repaired with asphalt and sloped gently away from the well box to promote drainage. Construction details for CP-11 are shown on Figure 1.3 and in Table 1.3.

FIGURE 1.3

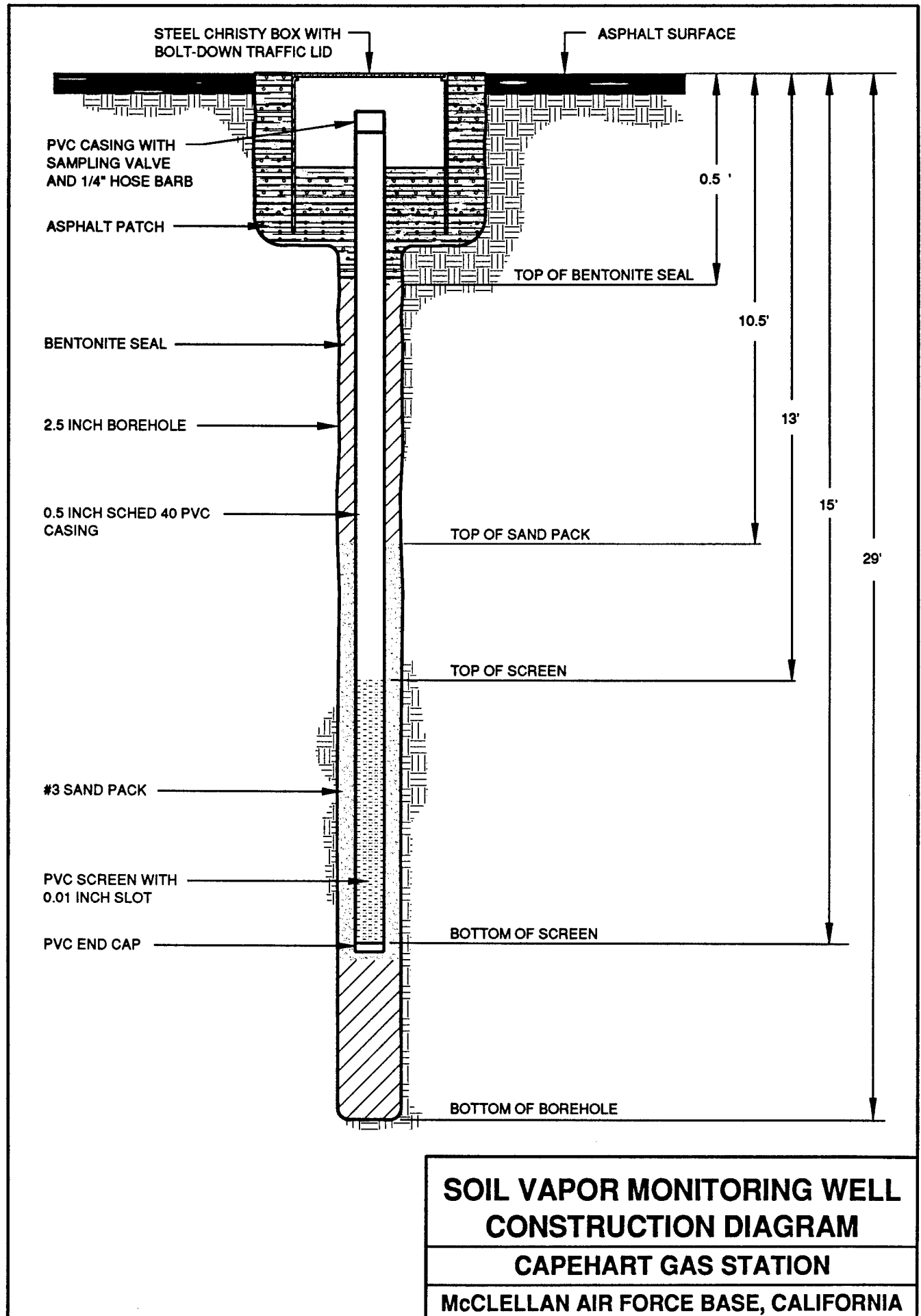

Soil samples were collected for field OVA of soil sample headspace during confirmatory soil sampling activities using the same procedures detailed in Section 1.2.1. Borehole, field OVA, and soil sample data for CP-8 through CP-11 are summarized in Table 1.1 and discussed in Section 2.

Downhole soil gas samples were also collected during confirmatory drilling. Samples were collected at approximately 10-foot intervals using a soil-gas probe advanced ahead of the Geoprobe[®] drive rods and driven approximately 1 to 2 feet into undisturbed soil. Downhole soil-gas results are shown in Table 1.2 and discussed in Section 2.

1.3 SOIL PROFILE

Figure 1.4 shows the soil profile encountered during drilling of VW-1, soil vapor monitoring wells CP-1, CP-2, and CP-4, and abandoned boring CP-6. Below the surface asphalt, the observed soil profile from the surface to a depth of approximately 15 feet bgs consists of brownish silts and clays. A lens of fine-grained silty sand lies between 5 and 10 feet bgs in the southern portion of the site. Below the near-surface brownish silts and clays is a layer of silty to clayey sand found to a depth of approximately 20 to 30 feet bgs. Below this sand layer and extending to the base of the deepest borehole at 109 feet bgs, the soil profile is predominantly silts and clays with minor interbedded sand lenses. These sand lenses are usually no more than 1 to 2 feet in thickness. Groundwater was encountered at a depth of 100 feet bgs during drilling of VW-1.

Noticeable fuel odors were encountered from the surface soils to approximately 25 feet bgs in VW-1, CP-9, CP-10, and CP-11. Figure 1.4 also shows the initial soil-gas oxygen levels for the SVMWs, the downhole soil-gas oxygen levels for VW-1, and the field OVA (soil headspace) readings for VW-1. These results are discussed in Section 2.

1.4 SOIL VAPOR EXTRACTION SYSTEM

As detailed in the work plan, prior to beginning air injection bioventing operations, soil vapor extraction (SVE) operations were performed in order to remove the initially high levels of volatile hydrocarbons from the soil. As detailed in a follow-up letter addendum to the work plan (Engineering-Science 1994b), an initial, short-term SVE test was performed to evaluate the extent of the volatile hydrocarbon mass in the subsurface prior to mobilizing a larger SVE system. This initial system utilized a portable blower unit to extract hydrocarbons from both VW-1 and CP-4, using granular activated carbon (GAC) for off-gas treatment. The process flow and instrumentation diagram for SVE into carbon is shown on Figure 1.5.

The initial system was operated at a flow rate of approximately 35 standard cubic feet per minute (scfm) for approximately 6.5 hours, after which breakthrough occurred in the second GAC unit. Field OVA readings with a total hydrocarbon vapor analyzer indicated that the concentration in the vapor stream was relatively constant at approximately 30,000 ppmv, resulting in a mass removal of approximately 105 pounds (lbs) or 48 kilograms (kg) of hydrocarbons. This is equivalent to approximately 18 gallons of liquid gasoline. Based on

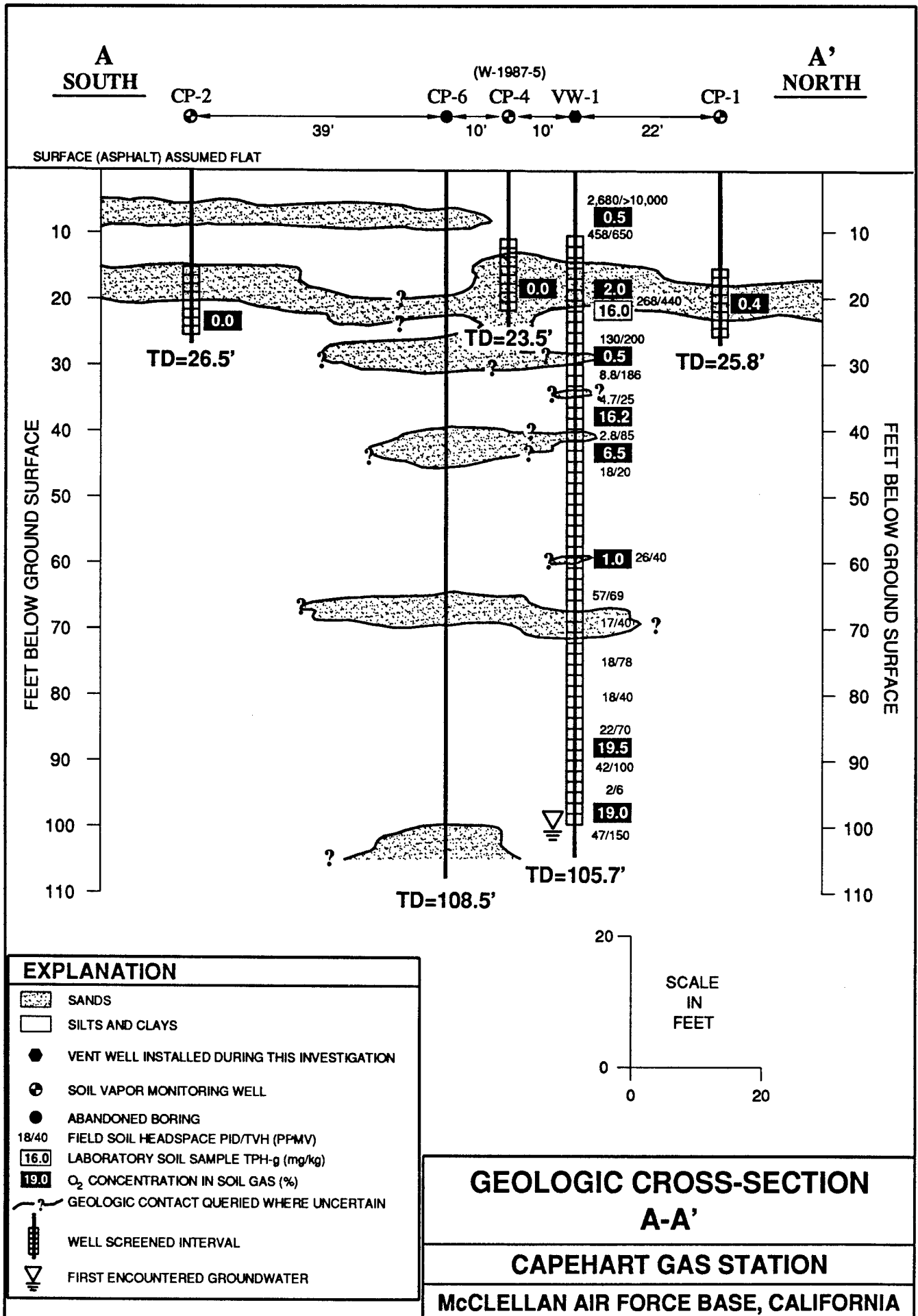

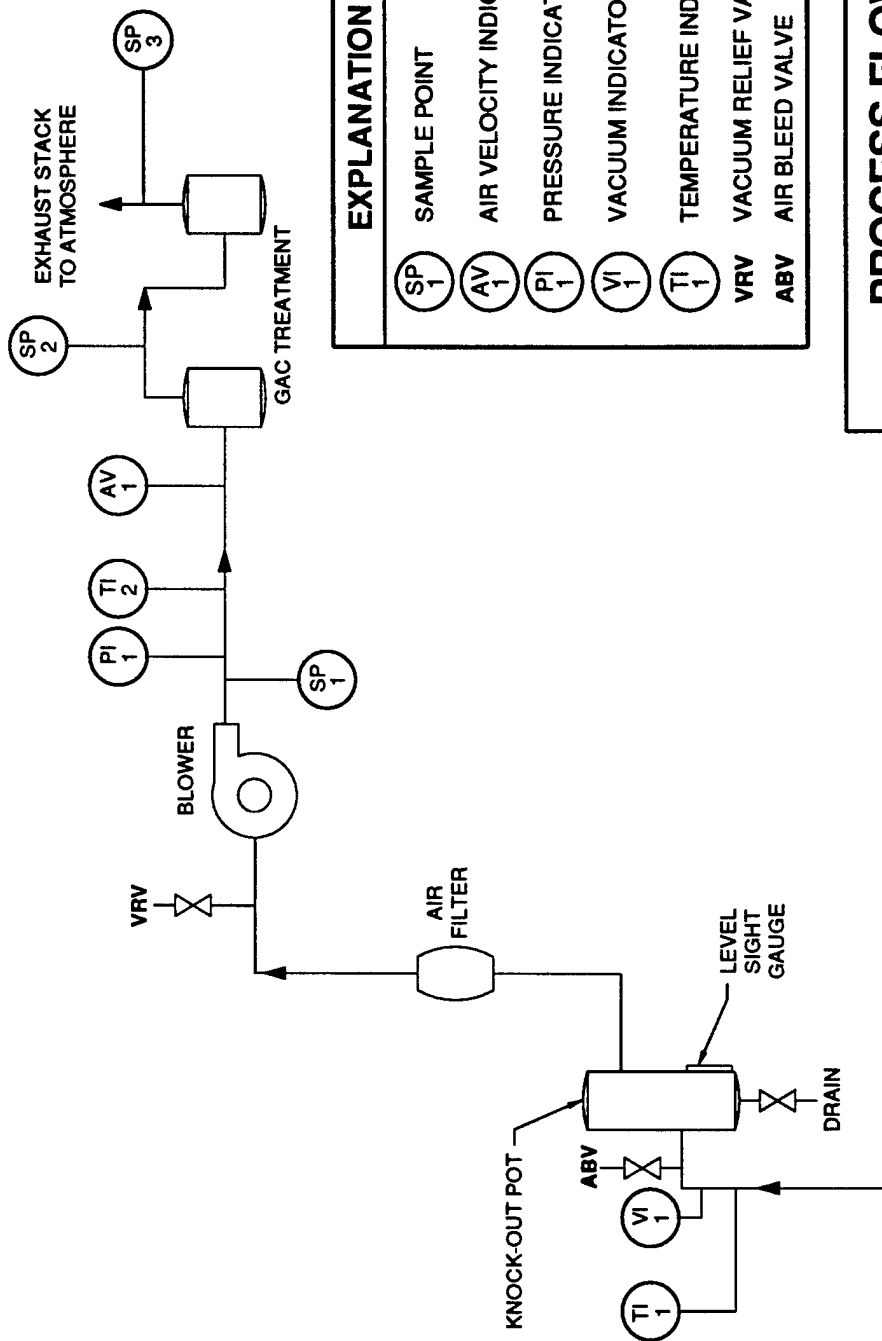

EXPLANATION	
SP 1	SAMPLE POINT
AV 1	AIR VELOCITY INDICATOR
PI 1	PRESSURE INDICATOR
VI 1	VACUUM INDICATOR
TI 1	TEMPERATURE INDICATOR
VRV	VACUUM RELIEF VALVE
ABV	AIR BLEED VALVE

PROCESS FLOW AND INSTRUMENTATION DIAGRAM SOIL VAPOR EXTRACTION INTO CARBON

CAPEHART GAS STATION

MCCLELLAN AIR FORCE BASE, CALIFORNIA

these results, it was determined that more extended SVE operations would be required at the site to reduce volatile hydrocarbon levels sufficiently before beginning air injection bioventing operations.

As detailed in the work plan, longer-term SVE operations with an internal combustion engine (ICE) were planned as Phase One of the pilot test prior to air injection bioventing operations. The process flow and instrumentation diagram for the SVE using an ICE is shown on Figure 1.6.

An Authority To Construct permit (Application No. 11706/11751) to operate a SVE system with an ICE was applied for and received from the Sacramento Metropolitan Air Quality Management District (SMAQMD) on 25 October 1994. The permit set emissions limits from the stack of 38 lbs/day of total hydrocarbons and 0.03 lbs/day of benzene and required 95 percent or better destruction efficiency. Natural gas was utilized as a supplemental fuel source to the ICE using a line installed by McClellan AFB. Initial startup and subsequent monthly compliance source tests were required by the permit to verify that emissions limits were being met. A series of letter reports were issued (Parsons ES, 1995a) detailing the results of these compliance source tests.

After 7 months of operation of the SVE system with the ICE, volatile hydrocarbon levels in the extracted soil gas decreased from 40,000 ppmv to 1,000 ppmv and benzene levels decreased from 1,400 ppmv to 1.5 ppmv. Additional results from operation of the SVE system are summarized in Section 3.5. A detailed performance and cost evaluation of the SVE system was delivered to the Air Force Center for Environmental Excellence (AFCEE) in a separate report (Parsons ES, 1995b).

1.5 AIR INJECTION BIOVENTING SYSTEM

Based on the decrease in concentration in the extracted soil gas after 7 months of SVE system operation (Section 1.4) and based on the *in situ* biodegradation capacity of the site soils (Section 3), concurrence was received from McClellan AFB and local regulatory agencies in June 1995 to proceed with Phase Two air injection bioventing operations, as detailed in the work plan (ES 1994a). The ICE was removed from the site and a fixed 1.0-HP Gast™ regenerative blower unit (model R4) was installed for the air injection bioventing system. Figure 1.7 shows the process flow and instrumentation diagram for the air injection system. The air injection flow rate was adjusted to 20 scfm, based on an evaluation of the required oxygen demand to sustain biodegradation and the estimated air-filled porosity of site soils (5-21 percent), as detailed in Appendix D. System monitoring was performed over a one-week period to verify that volatile hydrocarbons were not migrating along subsurface utilities or into the gas station shoppette building.

Parsons ES personnel provided an operations and maintenance (O&M) data collection sheet and blower maintenance manual to base personnel. A sample copy of the data collection sheet and maintenance manual is provided in Appendix B.

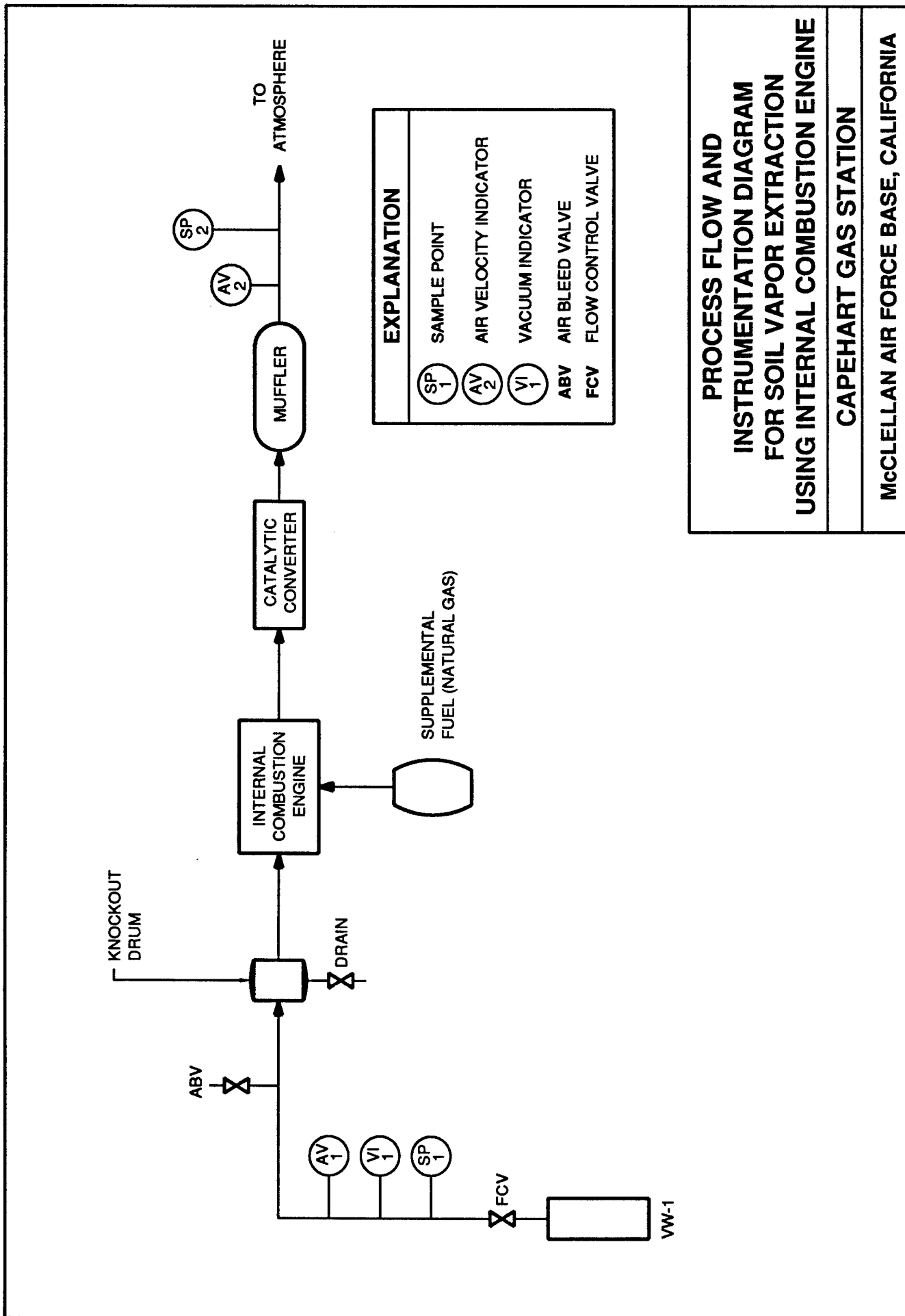

PROCESS FLOW AND INSTRUMENTATION DIAGRAM FOR SOIL VAPOR EXTRACTION USING INTERNAL COMBUSTION ENGINE

CAPEHART GAS STATION

MCCLELLAN AIR FORCE BASE, CALIFORNIA

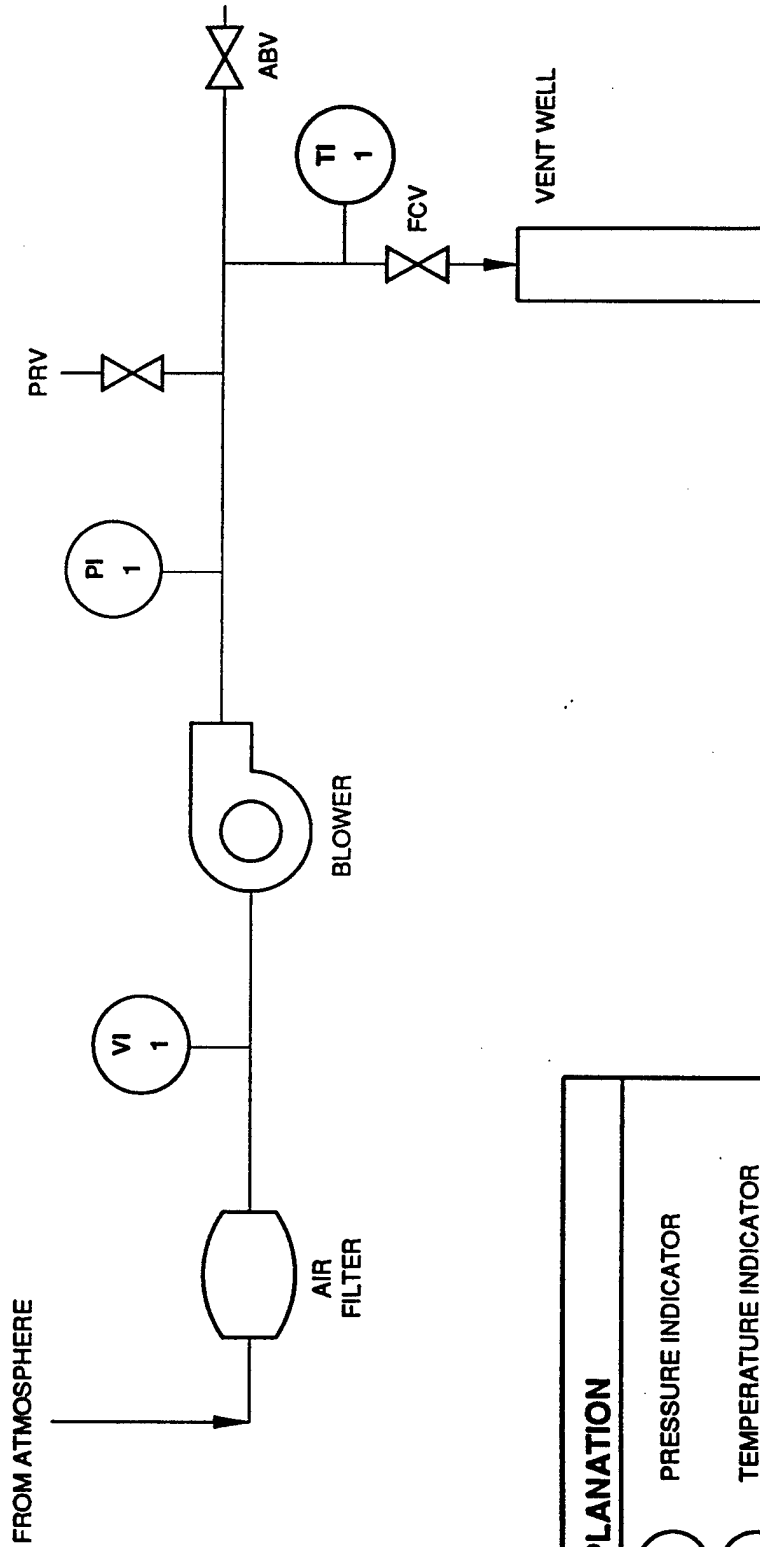

EXPLANATION	
	PRESSURE INDICATOR
	TEMPERATURE INDICATOR
	VACUUM INDICATOR
ABV	AIR BLEED VALVE
PRV	PRESSURE RELIEF VALVE
FCV	FLOW CONTROL VALVE

FLOW AND INSTRUMENTATION DIAGRAM
AIR INJECTION BLOWER SYSTEM
CAPEHART GAS STATION
MCCLELLAN AIR FORCE BASE, CALIFORNIA

SECTION 2

SOIL AND SOIL-GAS SAMPLING

2.1 SOIL SAMPLING

Contaminated soils were identified based on field observations such as visual appearance, odor, and OVA readings of soil sample headspace as described in the protocol document (Hinchee et al. 1992). OVA readings were monitored using both a PID and a THVA on all soil samples in order to estimate the relative amount and extent of soil contamination detectable by such devices. Soil sample headspace OVA readings were previously given in Table 1.1.

During initial drilling activities, soil samples were collected using a continuous split-spoon sampler lined with brass sleeves. During one-year drilling activities, soil samples were collected using the Geoprobe[®] drive sampler lined with clear acetate liners. All samples were preserved in the brass sleeves or clear acetate liners and immediately capped with Teflon[™] tape and plastic end caps. Selection of soil samples for laboratory analysis was based on field OVA readings, visual appearance, and odor.

Soil samples selected for laboratory analysis were delivered by overnight courier to PACE, Inc. in Huntington Beach, California, for chemical and physical analysis. Chain-of-custody forms are included in Appendix C. Analytes for all soil samples collected initially and during the one-year sampling event were: Total petroleum hydrocarbons as gasoline (TPH-g), and benzene, toluene, ethylbenzene, and total xylenes (BTEX). Samples collected from VW-1 during initial drilling activities also were analyzed for: iron; total alkalinity; pH; total Kjeldahl nitrogen (TKN); total phosphorus; moisture content; and grain size distribution. Samples to be analyzed for TKN, total phosphorus, and grain-size distribution were transferred to Sequoia Analytical in Redwood City, California.

During the initial drilling activities, soil samples for contaminant analysis were collected from VW-1 at depths of 21.5 and 96.5 feet bgs. A duplicate sample was collected from 96 feet bgs. Additional samples for inorganic analysis were also collected from approximately the same depths.

Because of the significant amount of mass removed during SVE operations at the site, during the one-year soil sampling event (Section 3) soil borings were drilled in an area of the site not previously investigated in an attempt to better delineate the source of the contamination. One boring, CP-8, was drilled at the southern end of the pump island because a small, aboveground leak was discovered at a pipe fitting at the southernmost fuel dispensing pump in May 1995. The leak was repaired a few days after discovery and it was unknown if any

subsurface contamination resulted from the leak. The three remaining borings, CP-9 through CP-11, were drilled north and northwest of the pump island (see Figure 1.1). Soil samples for contaminant analysis were collected from all boreholes: CP-8 (at 25.5 bgs), CP-9 (at 9.5 bgs), CP-10 (at 14 and 34 bgs), and CP-11 (at 17.5 and 26.5 bgs).

The analytical results for soil samples collected during initial drilling activities are summarized in Table 2.1. The analytical results for soil samples collected during the one-year soil sampling event are summarized on Table 2.2. These results are discussed in Section 2.3.

2.2 SOIL GAS SAMPLING

2.2.1 Downhole Sampling

Downhole soil gas sampling was conducted during both initial drilling activities and during the one-year soil sampling event at the request of McClellan AFB and local regulatory agencies. Soil gas probes consisted of a retractable tip and stainless steel mesh screen connected to the surface with dedicated tubing. After the tip was in place, the probe rods were raised to expose the screen and an air diaphragm pump at the surface was used to purge the tubing. The soil gas probe was removed after sample collection and decontaminated before use at the next interval.

After purging the probe tubing, the tubing and air diaphragm pump were connected to a vacuum chamber at the ground surface holding a 3-liter Tedlar® sample bag described in Section 2.5 of Addendum One to the protocol document (Hinchee et al. 1994). The chamber was evacuated with the air pump, filling the bag with the soil vapor sample. Soil vapor samples were analyzed in the field with an oxygen/carbon dioxide meter, a THVA, and a PID. Selected soil vapor samples were also collected for laboratory analysis by connecting a Summa canister with a vacuum gauge directly to the probe tubing.

Soil-gas samples selected for laboratory analysis were shipped to Air Toxics, Ltd. in Folsom, California for analysis of total volatile hydrocarbons as gasoline (TVH-g) and BTEX using EPA Method TO-3. Chain-of-custody forms are included in Appendix C.

2.2.2 Soil Vapor Monitoring Well Sampling

After well installation and prior to the *in situ* respiration tests, subsurface soil gas samples were collected from VW-1 and all SVMWs. After purging the individual casings and filter packs of at least one volume of air, *in situ* samples were collected for field and laboratory analysis using the procedures described in Section 2.2.1. Results are discussed in Section 2.3.

2.2.3 Soil Vapor Extraction System Sampling

As required under the air permit issued by the SMAQMD and in order to estimate mass removal rates with the SVE system, sampling points were installed on the SVE system at two locations (see Figure 1.6). Samples were collected and analyzed using the same procedures discussed in Section 2.2.1.

TABLE 2.1
INITIAL SOIL and SOIL GAS ANALYTICAL RESULTS
Capehart Gas Station
McClellan AFB, California

ANALYTE	METHOD	UNITS	SAMPLE LOCATION - DEPTH				
			(WELL NUMBER AND FEET BELOW GROUND SURFACE)				
Soil Hydrocarbons:			VW1-21.5	VW1-96.5	VW1-96¹		
TPH-g	8015M	(mg/kg)	16	<0.12	<0.12		
Benzene	SW8020	(mg/kg)	3.1	<0.0005	0.0009		
Toluene	SW8020	(mg/kg)	4.7	<0.0005	0.0052		
Ethylbenzene	SW8020	(mg/kg)	0.36	<0.0005	0.0012		
Xylenes, Total	SW8020	(mg/kg)	2.5	<0.0008	0.0072		
Soil Inorganics:			VW1-21.5	VW1-101	VW1-100.5²		
Iron	SW7380	(mg/kg dry wt.)	32,300	22,600	25,200		
Total Alkalinity	SM403	(mg/kg as CaCO ₃)	107	<50.3	153		
pH	SW9045	(units)	6.3	5.2	5.9		
TKN	E351.2	(mg/kg dry wt.)	100	<50	<51		
Total Phosphorus	E365.2	(mg/kg dry wt.)	400	71	56		
Soil Physical Parameters:			VW1-21.5	VW1-101	VW1-100.5²		
Moisture Content	ASTM D2216	(% by wt.)	16.2	20.6	13.1		
Gravel	ASTM D422	(% by wt.)	0.7	0.0	0.0		
Sand	ASTM D422	(% by wt.)	80.4	63.8	65.0		
Silt	ASTM D422	(% by wt.)	15.4	22.4	23.2		
Clay	ASTM D422	(% by wt.)	3.5	13.8	11.8		
Soil Gas Hydrocarbons (Downhole):			VW1-26.5	VW1-97.5			
TPH-g	EPA TO-3	(ppmv)	11,000	1,100			
Benzene	EPA TO-3	(ppmv)	150	9.6			
Toluene	EPA TO-3	(ppmv)	14	25			
Ethylbenzene	EPA TO-3	(ppmv)	2.9	1.7			
Xylenes, Total	EPA TO-3	(ppmv)	4.9	4.8			
Soil Gas Hydrocarbons			VW-1	CP-1	CP-2	CP-3	
TPH-g	EPA TO-3	(ppmv)	40,000	2,200	8.4	6,800	
Benzene	EPA TO-3	(ppmv)	1,100	4.8	0.013	270	
Toluene	EPA TO-3	(ppmv)	1,300	1.4	0.12	4.5	
Ethylbenzene	EPA TO-3	(ppmv)	180	0.75	0.032	43	
Xylenes, Total	EPA TO-3	(ppmv)	900	3.9	0.20	16	
Soil Gas Hydrocarbons			CP-4	CP-4³	CP-5	W1987-6	W1987-7
TPH-g	EPA TO-3	(ppmv)	29,000	32,000	13,000	1,000	310
Benzene	EPA TO-3	(ppmv)	300	330	140	<0.18	<0.10
Toluene	EPA TO-3	(ppmv)	540	590	150	0.76	1.4
Ethylbenzene	EPA TO-3	(ppmv)	44	49	32	0.40	0.32
Xylenes, Total	EPA TO-3	(ppmv)	500	550	190	0.83	1.4

NOTES:

TPH-g: Total Petroleum Hydrocarbons as gasoline

TKN - Total Kjeldahl nitrogen

¹ Duplicate, labelled as VW2-96

² Duplicate, labelled as VW2-100.5

³ Duplicate, labelled as CP10

ppmv - Parts per million by volume

CaCO₃ - Calcium carbonate

mg/kg - milligrams per kilogram

NA - Not Analyzed

TABLE 2.2
ONE-YEAR SOIL and SOIL GAS ANALYTICAL RESULTS
Capehart Gas Station
McClellan AFB, California

ANALYTE	METHOD	UNITS	SAMPLE LOCATION - DEPTH					
			(WELL NUMBER AND FEET BELOW GROUND SURFACE)					

Soil Hydrocarbons: CP8-25.5 CP9-9.5 CP10-14 CP10-34 CP11-17.5 CP11-26.5

TPH-g	8015M	(mg/kg)	<5.8	220	240	<6.2	260	<6.1
Benzene	SW8020	(mg/kg)	<0.058	<0.064	<0.053	<0.062	0.069	<0.061
Toluene	SW8020	(mg/kg)	<0.058	0.43	2.0	<0.062	4.3	<0.061
Ethylbenzene	SW8020	(mg/kg)	<0.058	1.3	2.3	<0.062	3.4	<0.061
Xylenes, Total	SW8020	(mg/kg)	<0.150	11	9.8	<0.160	10	<0.150

Soil Physical Parameters: CP8-25.5 CP9-9.5 CP10-14 CP10-34 CP11-17.5 CP11-26.5

Moisture Content	ASTM D2216	(% by wt.)	13.5	22.2	6.2	19.2	13.8	18.2
------------------	------------	------------	------	------	-----	------	------	------

Soil Gas Hydrocarbons (Downhole): CP9-10.5 CP10-15 CP10-30 CP11-10.5 CP11-28

TPH-g	EPA TO-3	(ppmv)	7,500	9,400	7.9	6,800	200
Benzene	EPA TO-3	(ppmv)	<1.0	19	0.012	31	0.32
Toluene	EPA TO-3	(ppmv)	350	1,300	0.27	360	5.7
Ethylbenzene	EPA TO-3	(ppmv)	200	210	0.13	64	1.3
Xylenes, Total	EPA TO-3	(ppmv)	1,200	780	0.78	390	10

Soil Gas Hydrocarbons VW-1 CP-1 CP-2 CP-3

TPH-g	EPA TO-3	(ppmv)	97	0.46	1.3	29
Benzene	EPA TO-3	(ppmv)	0.20	<0.002	<0.002	<0.005
Toluene	EPA TO-3	(ppmv)	0.23	<0.002	<0.002	0.016
Ethylbenzene	EPA TO-3	(ppmv)	0.34	<0.002	<0.002	0.068
Xylenes, Total	EPA TO-3	(ppmv)	5.0	<0.002	0.041	2.3

Soil Gas Hydrocarbons CP-4 CP-5 W1987-6 W1987-7

TPH-g	EPA TO-3	(ppmv)	470	1.9	37	42
Benzene	EPA TO-3	(ppmv)	1.7	<0.002	<0.010	<0.005
Toluene	EPA TO-3	(ppmv)	1.3	<0.002	0.031	0.020
Ethylbenzene	EPA TO-3	(ppmv)	2.4	<0.002	0.12	0.10
Xylenes, Total	EPA TO-3	(ppmv)	50	0.030	3.4	3.7

NOTES:

TPH-g: Total Petroleum Hydrocarbons as gasoline

ppmv - Parts per million by volume

mg/kg - milligrams per kilogram

¹ Duplicate, labelled as CP-9

The first sampling point was located where the distribution piping to VW-1 angled above ground, prior to the air bleed valve and ICE. This sampling point was used for sampling extracted soil gas before treatment or dilution. Analytical results and flow rates from this sampling point were used to calculate mass removal rates from the subsurface. The flow rate at the first sampling point was measured with an averaging pitot tube delivered as part of the ICE. Soil gas temperature was measured using a direct reading temperature meter connected to a Type K thermocouple probe.

The second sampling point was located in the exhaust stack after the catalytic converters and prior to discharge to the atmosphere. This sampling point was used for sampling vapors treated by the ICE and the catalytic converters. Analytical results and flow rates were used along with the results from the first sampling point to calculate destruction efficiencies, mass destruction rates, and mass emission rates to the atmosphere. The flow rate at the second sampling point was measured with a standard pitot tube temporarily inserted in the exhaust stack port and connected to magnehelic gauges for measurement of static and total pressure. Exhaust stack gas temperature was measured using a direct reading temperature meter connected to a Type K thermocouple probe.

Further information on the sampling results and process parameters measured during SVE system operation are contained in a series of letter reports required by the air emissions permit (Engineering-Science, 1994c; Parsons ES, 1995a). Results also are summarized in Section 3.5.

2.3 SAMPLING RESULTS AND SUBSURFACE CONTAMINATION

During initial drilling activities, laboratory analysis of soil samples documented only low levels of hydrocarbon contamination in VW-1 (Table 2.1). The sample collected from VW-1 at 21.5 feet bgs contained the maximum soil contaminant levels of 16 mg/kg TPH-g, 3.1 mg/kg benzene, 4.7 mg/kg toluene, 0.36 mg/kg ethylbenzene, and 2.5 mg/kg total xylenes. These results were consistent with results from previous site investigations that also indicated low levels of soil contamination.

During initial drilling activities, laboratory analysis of downhole soil gas samples and soil gas samples from the SVMWs collected prior to the ISR test documented significantly higher levels of hydrocarbons than expected based on the soil results (Table 2.1). At VW-1, the maximum soil gas contaminant levels were 40,000 ppmv TPH-g, 1,100 ppmv benzene, 1,300 ppmv toluene, 180 ppmv ethylbenzene, and 900 ppmv total xylenes. VW-1 is the SVMW located nearest to the fuel line leak discovered in 1987. The highest levels were found east of the former fuel line leak in VW-1, CP-4, and CP-5, with contaminant levels decreasing with distance from the leak location. These results suggested that hydrocarbon contamination was either primarily in the volatile state, the soil contamination was very heterogeneously distributed in the subsurface, or it was located in an area of the site not previously investigated.

During the one-year sampling event, soil samples were collected in two areas of the site suspected to be the source of the significant mass removed by the SVE system (Section 3.4): west of the former fuel line break, where no borings had been previously drilled, and

immediately south of the pump island, near the location of the aboveground leak discovered during SVE operations in May 1995 (Figure 1.1). Laboratory analysis of soil samples documented significantly higher levels of hydrocarbon contamination in CP-9, CP-10, and CP-11 than that found at the site in previous investigations (Table 2.2). The maximum contaminant levels in soil from these borings were: 260 mg/kg TPH-g, 0.069 mg/kg benzene, 4.3 mg/kg toluene, 3.4 mg/kg ethylbenzene (all from CP-11 at 17.5 ft bgs), and 11 mg/kg total xylenes (from CP-9 at 9.5 feet bgs). No contamination was detected in soil samples collected from the bottom of CP-10 and CP-11 at 34 and 26.5 feet bgs, respectively. No contamination was detected in the sample collected from CP-8.

During the one-year sampling event, laboratory analysis of downhole soil gas samples and soil gas samples from the SVMWs collected prior to the ISR test correlated better with the soil results. Significant reductions in concentration resulted from the SVE and air injection bioventing operations. The maximum contaminant levels in soil gas were: 9,400 ppmv TPH-g (CP-10 at 15 feet bgs), 31 ppmv benzene (CP-11 at 10.5 feet bgs), 1,300 ppmv toluene (CP-10 at 15 feet bgs), 210 ppmv ethylbenzene (CP-10 at 15 feet bgs), and 780 ppmv total xylenes (CP-10 at 15 feet bgs). For the SVMWs where concentrations were measured both before and after SVE and bioventing operations, the maximum TPH-g concentration was reduced from 40,000 ppmv to 97 ppmv (99.76 percent reduction), the maximum benzene concentration was reduced from 1,100 ppmv to 1.7 ppmv (99.85 percent reduction), and the total BTEX concentration was reduced from 3,500 ppmv to 55 ppmv (99.43 percent reduction).

Because these soil and soil gas samples were collected after SVE operations, it is likely that the area of the site west of the former fuel line break was the source of the contaminant mass removed by the SVE operations (Section 3.4). Based on the soil and soil gas results from CP-8, the aboveground leak at the southern fuel dispensing pump does not appear to have impacted subsurface soil.

The results from soil and soil gas samples collected at the bottom of the boreholes suggest that the contamination is currently not vertically extensive; however, the maximum borehole depth during the one-year sampling event was only 34 feet bgs. Maximum downhole soil-gas contaminant concentrations, field OVA readings, and oxygen depletion were initially between ground surface and 30 feet bgs, as measured in VW-1 (Figure 1.1 and Table 2.1).

Although the horizontal extent of contamination west and north of CP-9, CP-10, and CP-11 remains unknown, the radius of influence from both the SVE system and the air injection bioventing system ranged from 70 feet to 120 feet from VW-1 (Section 3.2), depending on the flow rate. Vacuum and pressure influences were measured in all SVMWs at the site. These results suggest that the previously operated SVE system and the currently operating air injection bioventing system can sufficiently remediate the contamination at the site as it is currently defined.

2.4 QA/QC RESULTS

Duplicate soil samples were collected from VW-1, as shown in Table 2.1. The analytical results for duplicate soil samples are consistent with the primary soil samples. A field

duplicate soil-gas sample was collected from CP-4 during initial soil gas sampling activities. The analytical results for the soil-gas duplicate are consistent with the analytical results from the primary sample.

At the one-year sampling event, no duplicate soil or soil gas samples were collected.

2.5 EXCEPTIONS TO STANDARD BIOVENTING PILOT TESTING PROTOCOL

The following exceptions were made to standard protocol procedures:

1. Due to the high initial soil gas levels, SVE was used to reduce the risk of vapor migration. Only after the average soil gas levels were decreased below 1,000 ppmv was a low rate of air injection bioventing initiated.
2. An interim (six-month) ISR test was not performed at the site. Elimination of the interim ISR test allowed air injection bioventing operations to begin immediately after SVE operations and prevented the possible increase of volatile hydrocarbons in subsurface soil gas.
3. Downhole soil gas sampling was performed at the request of McClellan AFB and local regulatory agencies.
4. One-year soil sampling did not take place at the same locations sampled initially. Because significant soil contamination was not found initially, one-year soil sampling was conducted in areas of the site not previously investigated in order to provide further site characterization information and expedite future site closure activities.

SECTION 3

PILOT TEST RESULTS AND RECOMMENDATIONS

3.1 SOIL GAS CHEMISTRY

Prior to initiating air injection, VW-1 and all SVMWs were purged until oxygen levels had stabilized, and then initial oxygen, carbon dioxide, and TVH (total volatile hydrocarbon) concentrations were sampled using portable gas analyzers as described in the protocol document (Hinchee et al. 1992). Depleted oxygen levels and increased carbon dioxide levels were found in soil gas at VW-1 and at all SVMWs screened intervals, indicating soil contamination and natural biological activity in site soils. The initial soil-gas chemistry measured is summarized in Table 3.1. TVH and benzene for soil-gas samples are also provided to demonstrate the relationship between oxygen levels and the contaminated soils.

3.2 AIR PERMEABILITY

An air permeability (AP) test was not conducted at the site because a test was previously conducted in January 1992 by CH2M Hill, as detailed in the work plan (ES 1994a; CH2M Hill 1992). Based on the January 1992 test data, the air permeability of the soil over the tested depth (10 to 25 feet bgs) ranged from 45 to 150 darcys. These results were calculated based on the dynamic response of the soil to air extraction at CP-4. Assuming steady-state conditions at the end of one hour test, the average air permeability was calculated by CH2M Hill at 14 darcys. The radius of influence based on vacuum response during the same test was estimated at 70 feet at a flow rate of 20 scfm and an induced vacuum in the extraction well (CP-4) of 44 inches of water.

Throughout the operation of the SVE system and air injection bioventing operations, vacuum and pressure responses were measured in the SVMWs. Air extraction and air injection flow rates also were measured. Using these vacuum and pressure responses at steady-state conditions, the average air permeability was calculated and ranged from 2.2 to 11 darcys. Air permeability was calculated using the procedures detailed in the protocol document. The steady-state vacuum response measured in April 1995 during SVE operations is shown on Figure 3.1 and the steady-state pressure response measured in July 1995 during air injection bioventing operations is shown on Figure 3.2. The radius of influence based on vacuum and pressure response are also shown on Figure 3.1 and Figure 3.2.

The calculated air permeability values from all tests are within the range typical for the silty sands found within the test zone. The tests indicated that the soils are sufficiently permeable for SVE and air injection bioventing to be effective. The air permeability calculations were based on pressure and vacuum response in SVMWs which are screened

TABLE 3.1
INITIAL SOIL GAS CONDITIONS
Capehart Gas Station
McClellan AFB, California

Location	Screened Interval (feet)	Field Analysis			Laboratory Analysis	
		O ₂ (%)	CO ₂ (%)	TVH (ppmv)	TVH-g (ppmv)	Benzene (ppmv)
VW-1	10 to 105	0.0	9.5	2,000	40,000	1,100
CP-1	15 to 25	0.4	15.2	2,000	2,200	4.8
CP-2	15.8 to 25	0.0	10.2	60	8.4	0.013
CP-3	15.7 to 25.7	0.0	14.0	480	6,800	270
CP-4	10.8 to 20.8	0.0	14.5	1,000	29,000	300
CP-5	14.7 to 19.7	0.0	7.5	750	13,000	140
W1987-6	14.8 to 33.6	0.0	11.0	1,050	1,000	<0.18
W1987-7	8 to 35	1.0	11.0	360	310	<0.10

NOTES

TVH-g : Total Volatile Hydrocarbons as gasoline (EPA TO-3)
 TVH : Total Volatile Hydrocarbons (field instrument)
 ppmv : parts per million, by volume

Air Permeability During SVE Operations (April 1995)
Steady-State Calculation Method
Capehart Gas Station - McClellan AFB, California

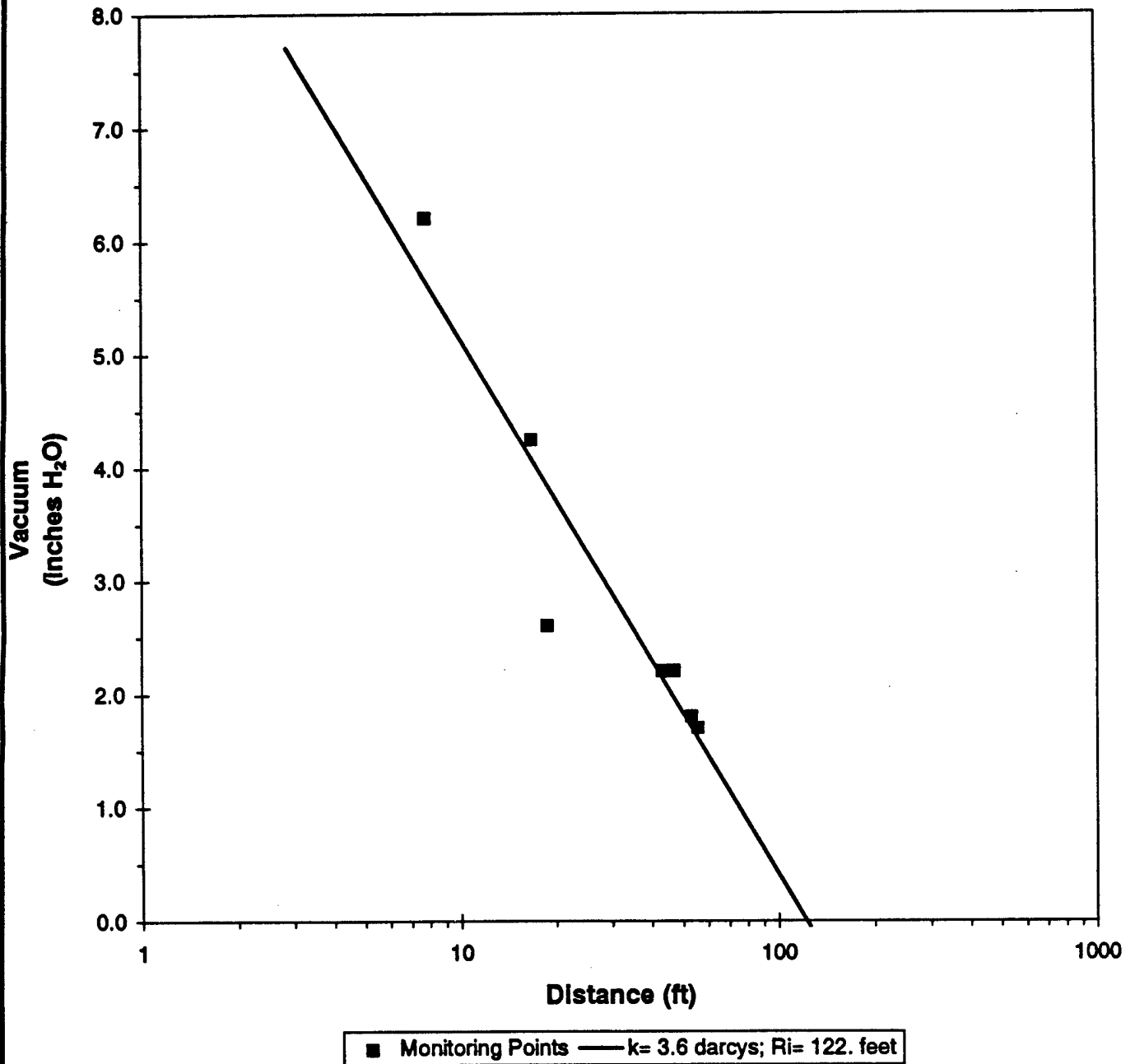

**Air Permeability During Air Injection Operations (July 1995)
Steady-State Calculation Method
Capehart Gas Station - McClellan AFB, California**

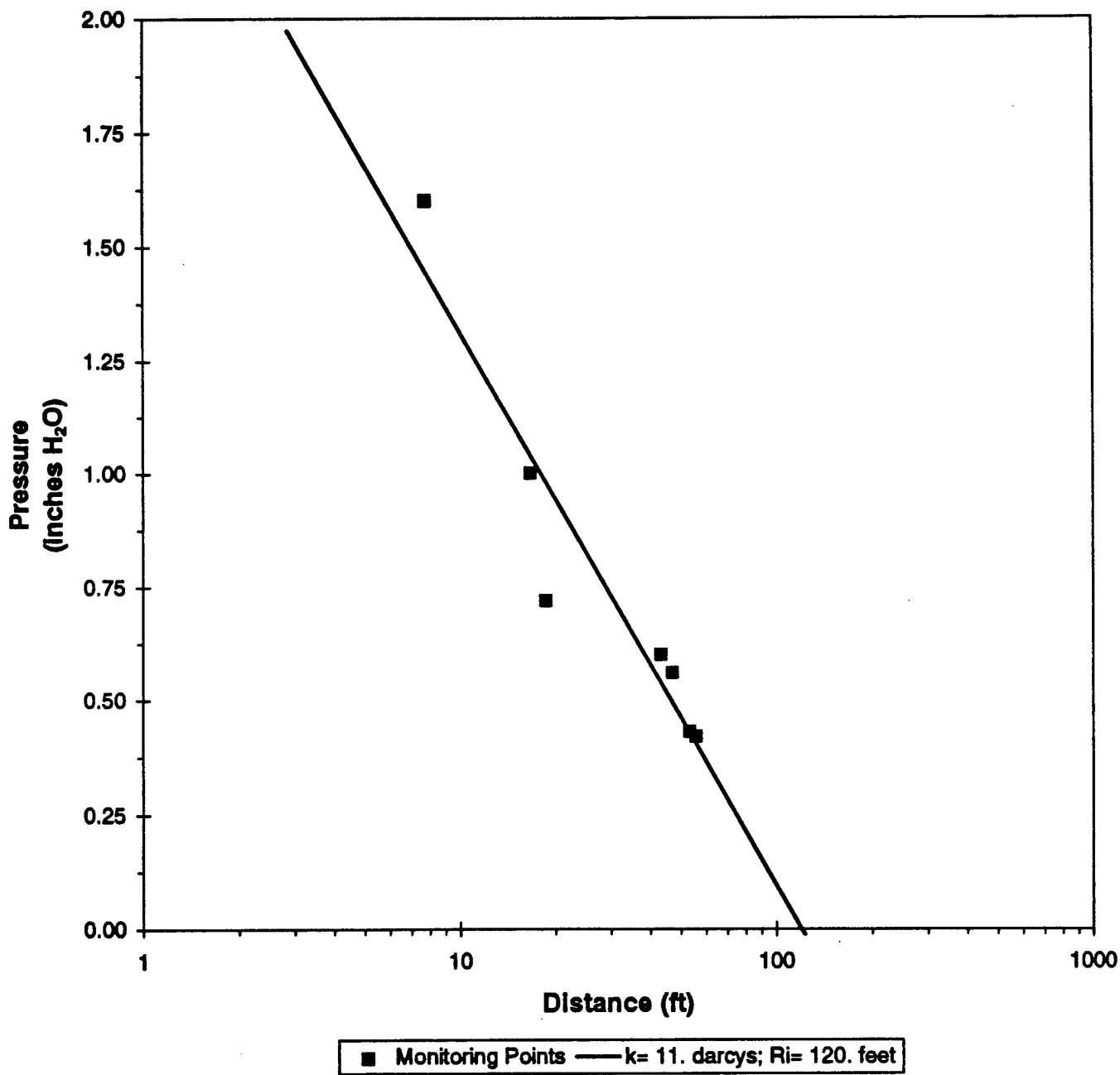

only as deep as 25 feet bgs; therefore, the permeability of the silty clays below 25 feet bgs could not be determined. However, recent field studies have shown that bioventing can be effective in low permeability soils (Downey et al. 1992, Phelps et al. 1995), especially when some silt or sand fractions are present, which is the case at this site (see Appendix A).

3.3 OXYGEN INFLUENCE

The depth and radius of oxygen influence in the subsurface resulting from air extraction from or air injection is a primary design parameter for bioventing systems. The pilot test data determine the volume of soil that can be oxygenated at a given flow rate and VW screen configuration. Table 3.2 presents the change in soil-gas oxygen levels in the SVMWs as a result of air extraction (SVE) operations.

Increases in soil-gas oxygen levels occurred at all SVMWs, indicating successful oxygen transport at a radial distance of at least 50 feet. Based on measurable vacuum and pressure responses during the SVE operations and during the air injection bioventing operations (Section 3.2), which are indicators of long-term oxygen transport, it is anticipated that the radius of oxygen influence during both SVE operations and air injection bioventing operations is at least 50 feet and is likely as high 120 feet from VW-1.

3.4 *IN SITU* RESPIRATION RATES AND BIODEGRADATION RATES

An initial *in situ* respiration (ISR) test was conducted between 25 and 27 May 1994 according to protocol document procedures. Air with an oxygen concentration of 20.8 percent was injected at a rate of approximately 1 scfm into three SVMW screened intervals (CP-1, CP-3, and CP-4) for 22 hours in order to oxygenate surrounding soils. After air injection was ceased, oxygen, carbon dioxide, and TVH levels in all SVMW screened intervals (including those without air injection) were measured in soil gas for the following 24.5 hours. The results of the ISR test are presented on Figures 3.3 to 3.7 and summarized in Table 3.3.

Results from the ISR test indicate that all of the SVMW screened intervals had hydrocarbon contamination and active microorganism populations. The oxygen-utilization rates measured at the site were moderate to average, ranging from approximately 0.10 percent per hour at CP-4 to approximately 0.29 percent per hour at VW-1. During the ISR test, the soil temperature in VW-1 was measured at 75.5 °F.

The air injected into the SVMWs during the ISR test was a 5.9-percent helium mixture in air. The helium is used both as a tracer gas and to evaluate the effectiveness of the bentonite seals in the VW and SVMWs. No appreciable loss of helium occurred at any SVMWs where helium was injected between the end of injection and the final ISR readings taken after 31 hours of monitoring. Therefore, most of the oxygen loss observed during the ISR test was a result of bacterial respiration and not a result of either faulty well construction or overpurging of the SVMWs during sampling.

TABLE 3.2
INFLUENCE OF SOIL VAPOR EXTRACTION
AND AIR INJECTION ON OXYGEN LEVELS
Capehart Gas Station
McClellan AFB, California

Location	Distance from VW-1	Soil Gas Oxygen (%)		
		Jun 1994 ¹	Nov 1994 ²	Jul 1995 ³
VW-1	-	0.0	12.9	20.8
CP-1	18.8	0.4	20.8	20.5
CP-2	53.5	0.0	20.5	20.3
CP-3	43.3	0.0	17.7	20.0
CP-4	7.8	0.0	18.4	20.6
CP-5	16.8	0.0	18.3	20.0
W1987-6	47.2	0.0	20.0	20.2
W1987-7	55.9	1.0	20.2	20.2

NOTES

- ¹ : Prior to ISR Test
- ² : After 4 weeks of air extraction
- ³ : After 7 months of air extraction and 3 weeks of air injection

Respiration Test at VW-1 Capehart Gas Station - McClellan AFB, CA

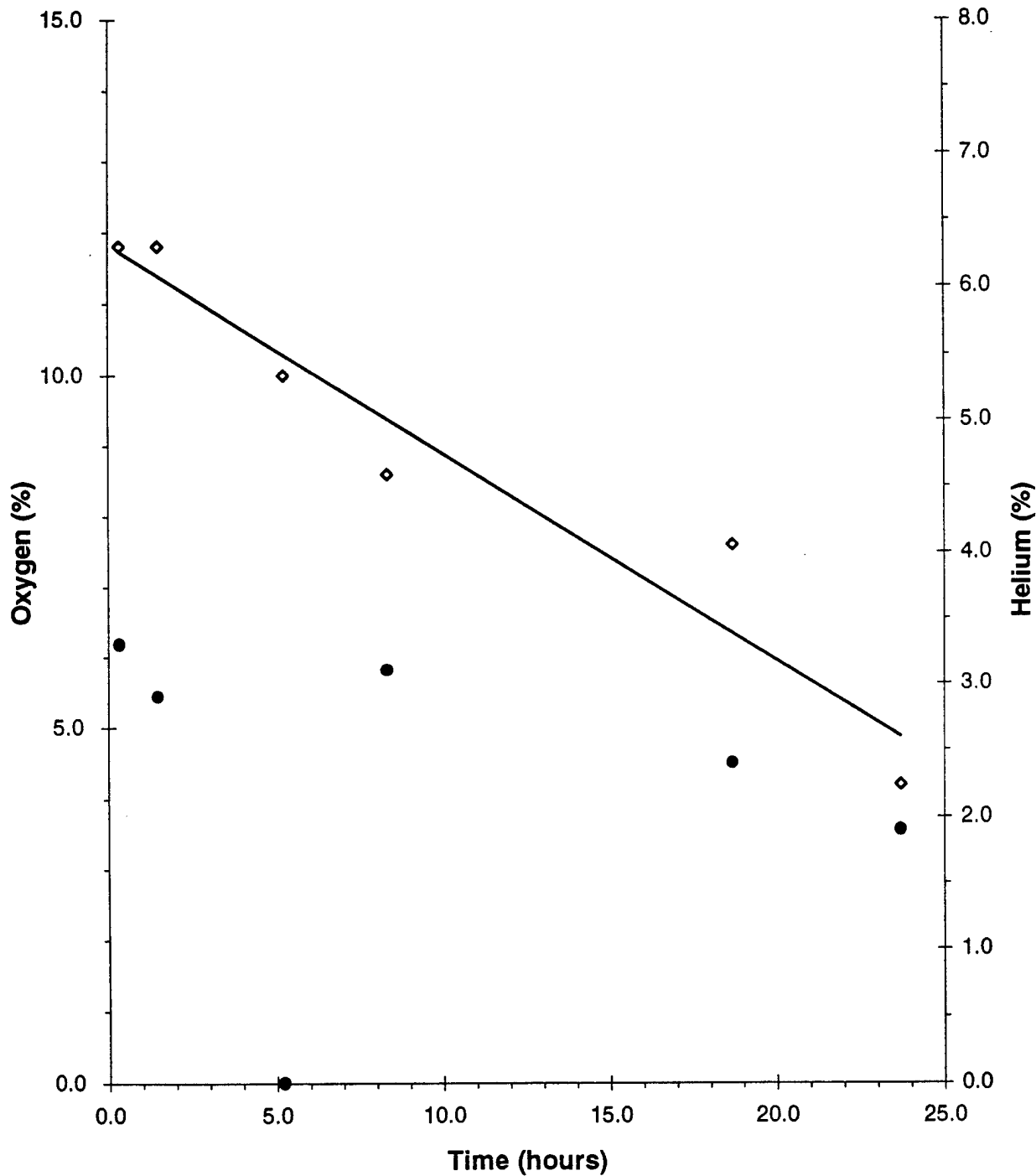

◇ VW-1,O2 (%) — $k=0.29\%/\text{hr}$
(Oxygen utilization rate) ● VW-1,He(%)

Respiration Test at CP-1
Capehart Gas Station - McClellan AFB, CA

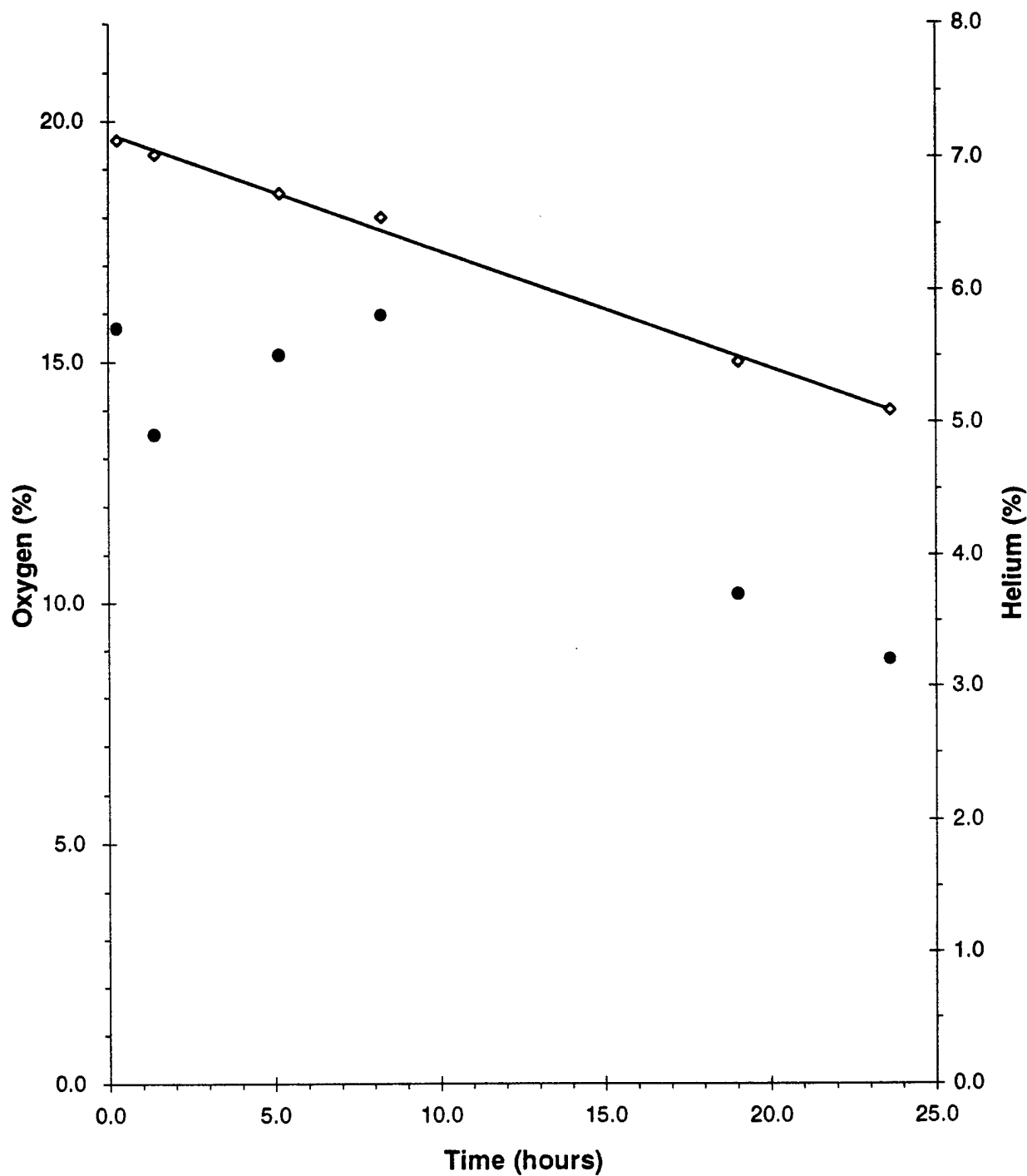

CP-1,O2 (%)
 $k = .24\%/\text{hr}$
 (Oxygen utilization rate)
 CP-1,He(%)

Respiration Test at CP-3
 Capehart Gas Station - McClellan AFB, CA

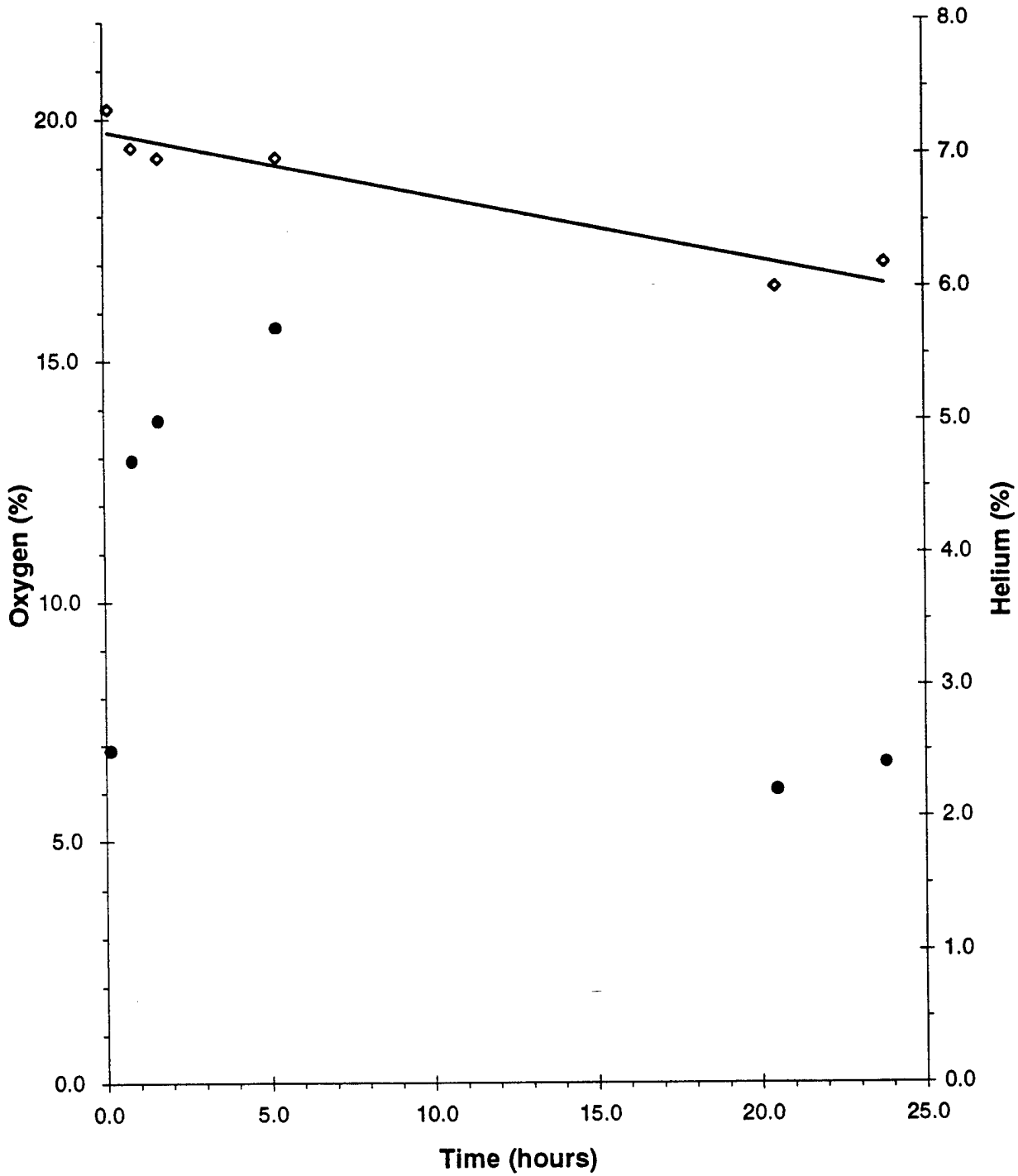

CP-3,O₂ (%)
 $k = .13\%/\text{hr}$
 (Oxygen utilization rate)
 CP-3,He(%)

Respiration Test at CP-4
Capehart Gas Station - McClellan AFB, CA

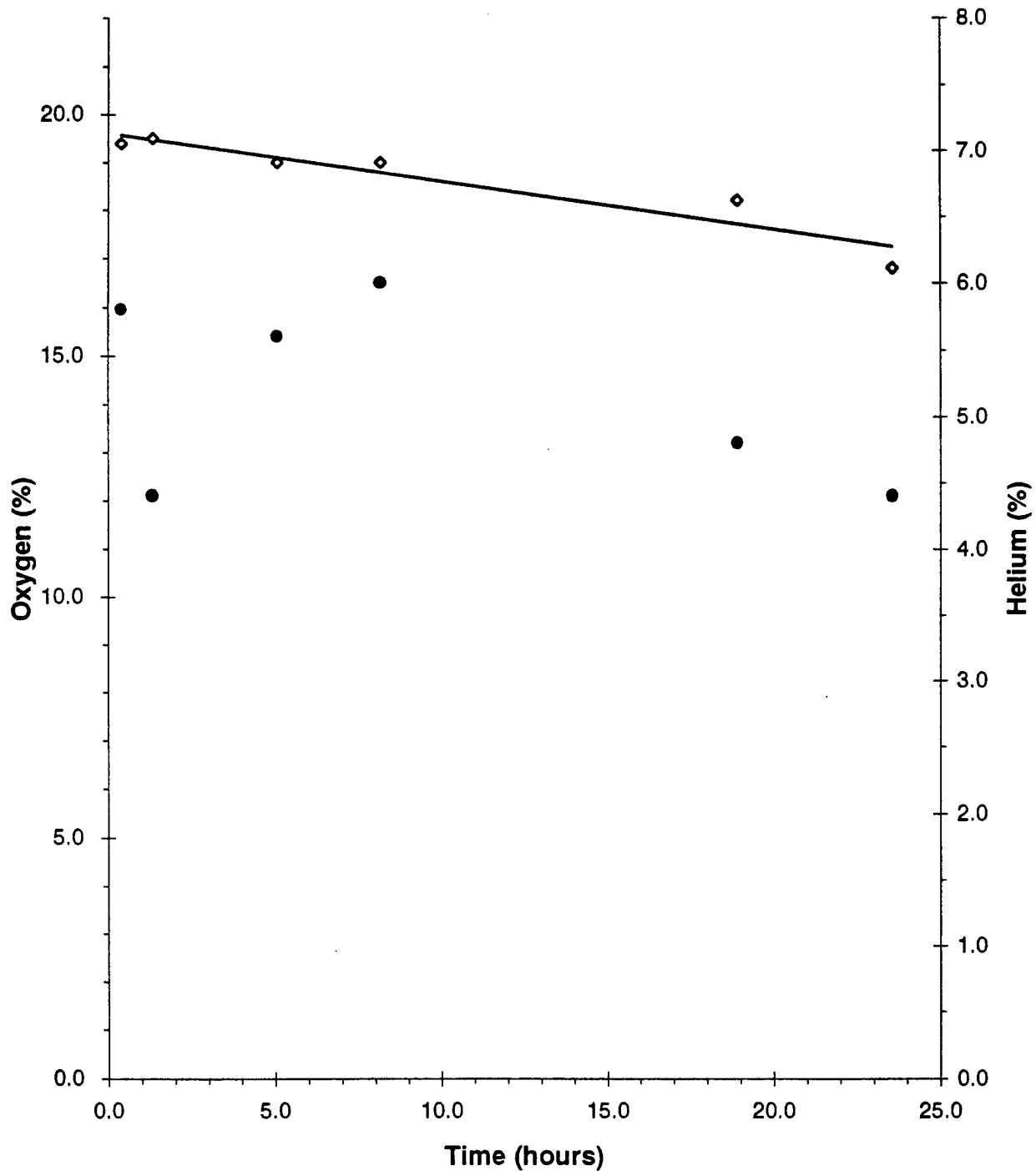

CP-4, O₂ (%)
 $k = .10\%/\text{hr}$
 (Oxygen utilization rate)
 CP-4, He(%)

Respiration Test at CP-5
Capehart Gas Station - McClellan AFB, CA

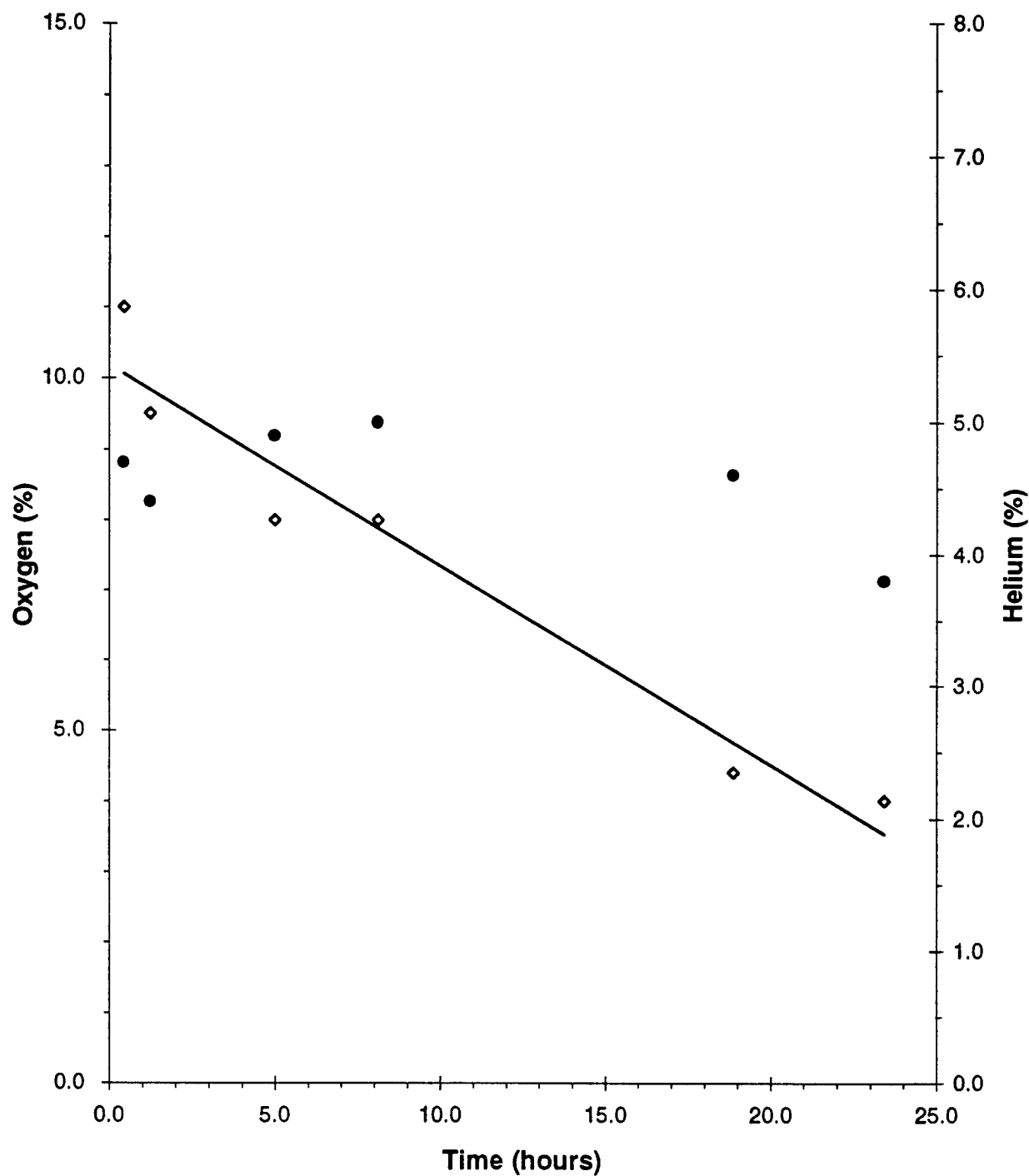

CP-5, O2 (%)
 k = .28 %/hr (Oxygen utilization rate)
 CP-5, He(%)

TABLE 3.3
PILOT TEST DATA SUMMARY
Capchart Gas Station
McClellan AFB, California

Location	Screened Interval (feet)	Laboratory Analytical Results			In Situ Respiration Tests			Biodegradation Rate, K _b	
		TPH-g (ppmv)	Total BTEX (ppmv)	Equilibrium Soil Gas O ₂ (%)	O ₂ Utilization Rate (%/hr)	(mg fuel/kg soil per yr)	1-Year		
VW-1	9 to 105	Initial	Initial	Initial	Initial	Initial	Initial	Initial	
CP-1 •	15 to 25	1-Year	1-Year	1-Year	1-Year	1-Year	1-Year	1-Year	
CP-2	15.8 to 25	97	3,500	8.1	0.29	580	580	220	
CP-3 •	15.7 to 25.7	0.46	11	13.8	0.24	640	640	220	
CP-4 •	10.8 to 20.8	8.4	0.37	0.0	0.0	---	---	---	
CP-5	14.7 to 19.7	29	330	17.3	0.13	100	100	40	
W1987-6	14.8 to 33.6	470	1,400	9.2	0.10	380	380	200	
W1987-7	8 to 35	13,000	510	14.0	0.28	580	580	90	
		1,000	2.0	19.8	---	---	---	---	
		310	2.8	19.8	---	---	---	---	

NOTES

TPH-g : Total petroleum hydrocarbons as gasoline (EPA TO-3)
 BTEX : Benzene, Toluene, Ethylbenzene, and Total Xylenes (EPA TO-3)

• : VMP used for air injection during ISR test
 ppmv : parts per million by volume

Helium was also monitored at VW-1 and at SVMWs where air injection did not occur. Detection of helium at these points provides some evidence that significant volumes of soil were aerated by the 1 scfm pumps and consistent helium levels at these points over time indicates that decreasing oxygen levels in extracted soil-gas are due to respiration.

Based on the measured oxygen-utilization rates and the laboratory analyses presented in Section 2.0, an estimated 100 to 640 milligrams (mg) of fuel per kilogram (kg) of soil can be biodegraded each year at this site. The lower estimate reflects the slower oxygen-utilization rate and higher moisture content measured at CP-3, while the higher estimate reflects the higher oxygen-utilization rate and lower moisture content measured at CP-1. The biodegradation rate estimates are based on calculated air-filled porosities and a ratio of 3.5 mg of oxygen consumed for every 1 mg of fuel biodegraded. Methods of calculation followed the procedures in the protocol document and are detailed in Appendix D.

Additional respiration testing was performed after approximately one year (7 months of SVE operation followed by 5 months of air injection operations). Results from the one-year ISR test also are shown in Table 3.3. As expected, the significant reductions in contaminant mass resulted in slower oxygen-utilization rates and lower rates of biodegradation when compared to the rates measured prior to SVE operations. However, the one-year results indicate that biodegradation is still progressing at a significant rate at the site. The one-year oxygen-utilization rates ranged from approximately 0.043 percent per hour at CP-5 to approximately 0.11 percent per hour at VW-1. Based on these measured oxygen-utilization rates, an estimated 40 to 220 mg of fuel per kg of soil are still being biodegraded each year at the site.

3.5 MASS REMOVAL

Based on the monthly test data (Section 2.2.3), the amount of mass removed from the subsurface by SVE and combusted by the ICE was estimated at approximately 11,000 lbs (5,000 kg) over the 7-month period of operation. Figure 3.8 presents a graph of the reductions in contaminant concentration over time for the extracted soil gas. The mass removal rate over time is shown on Figure 3.9.

Additional mass was also removed from the subsurface by biodegradation induced by the increase in oxygen from the SVE system. Mass removed by biodegradation was estimated by using the difference between the background oxygen level and the oxygen level measured in the extracted soil gas (Hinchee and Leeson 1995). The total mass removed by biodegradation during SVE operations was estimated at approximately 8,000 lbs (3,600 kg). Therefore, the total amount of mass removed from the subsurface during SVE operations was estimated at approximately 19,000 lbs (8,600 kg) of hydrocarbons or an equivalent of approximately 3,200 gallons of liquid gasoline. Additional mass is currently being biodegraded with the ongoing operation of the air injection bioventing system (Section 3.4).

Influent TVH-g and Extraction Flow Rate Vs. Time and Total SCF Treated Capehart Gas Station - McClellan AFB, California

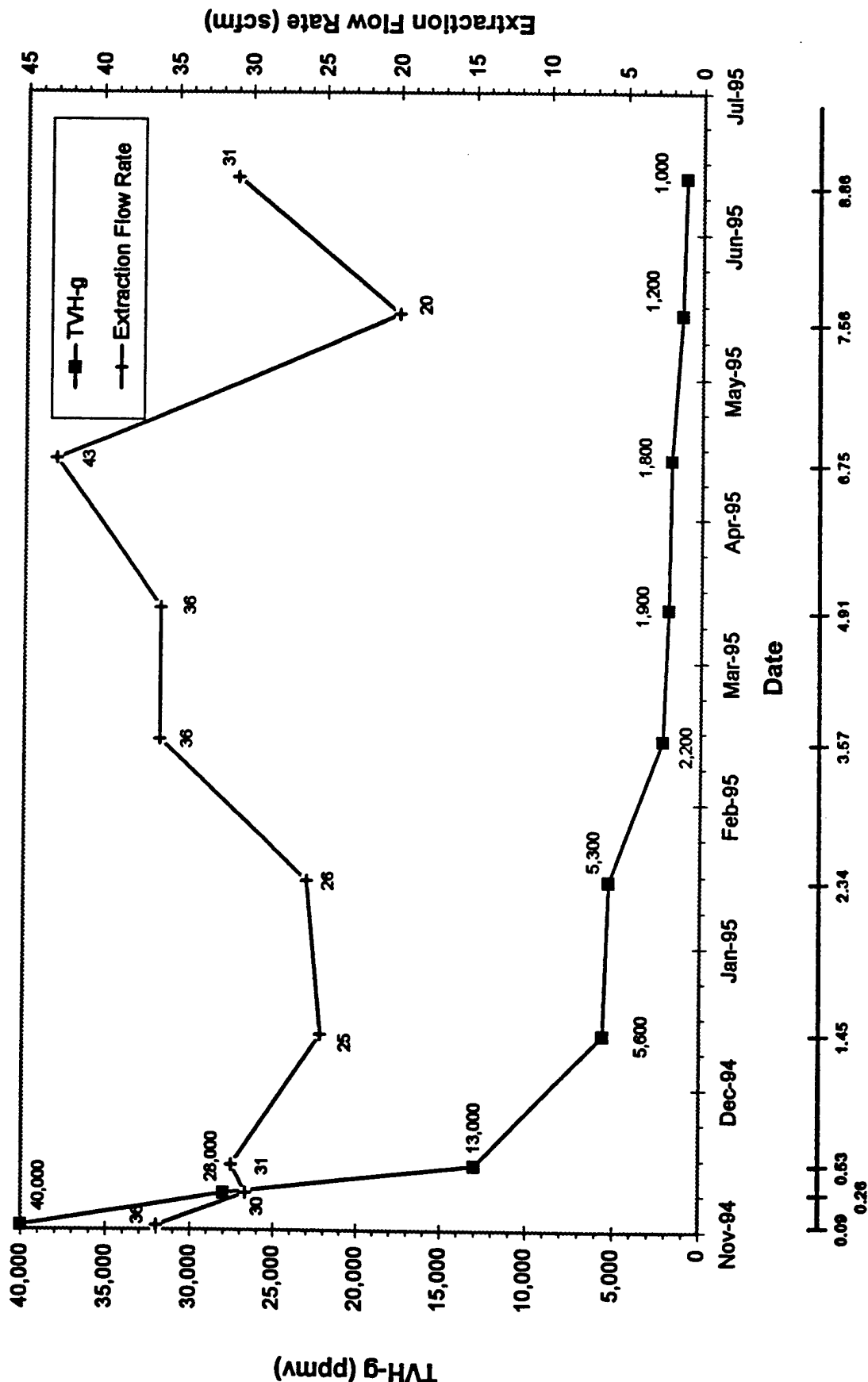

SCE (x 1 Million) TREATED

Mass Removal Rates Vs. Time and Total SCF Treated Capehart Gas Station - McClellan AFB, California

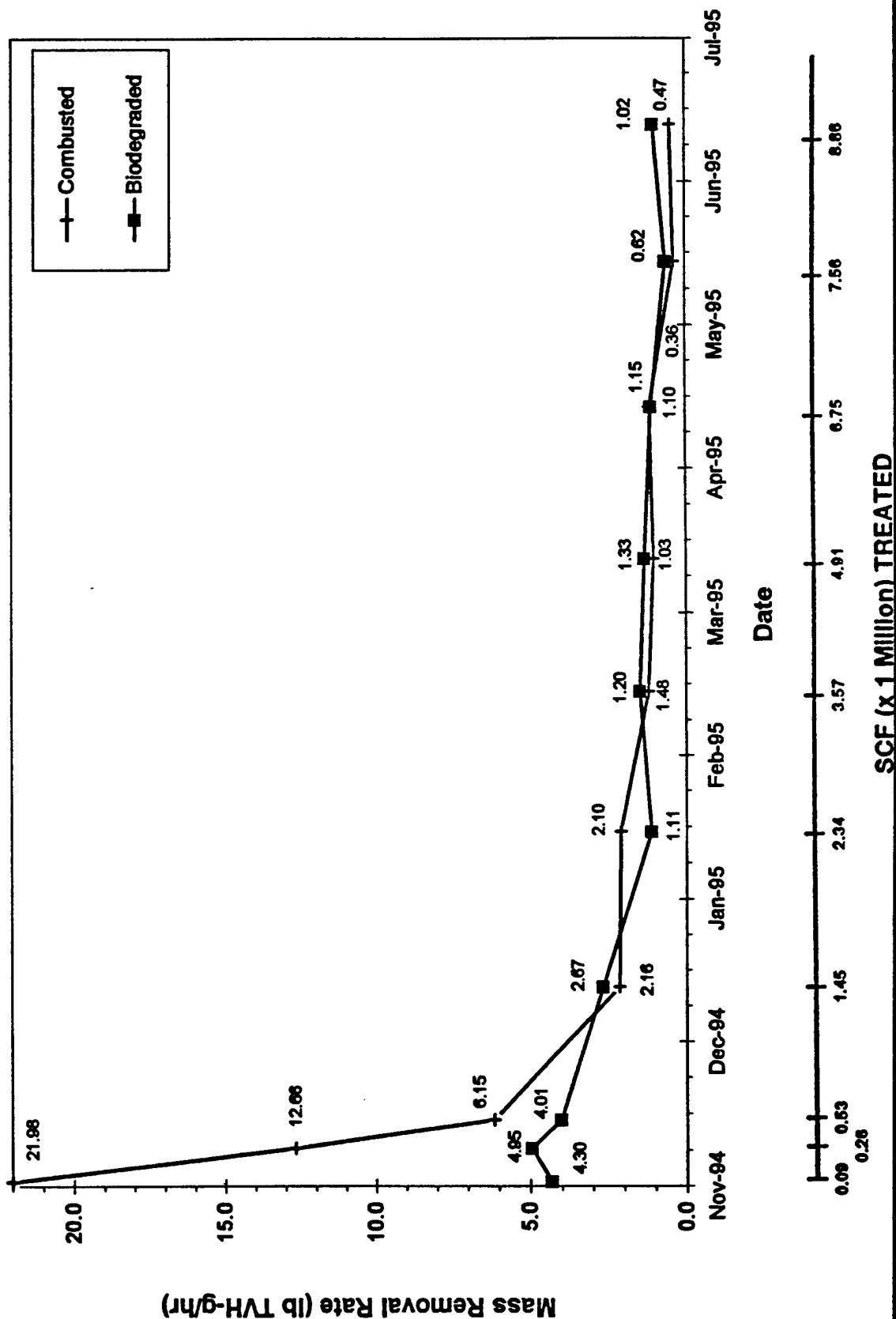

3.6 RECOMMENDATIONS

The bioventing pilot test at the site indicated that oxygen was initially depleted in the contaminated soils and air extraction and air injection are effective methods of increasing aerobic biodegradation of fuel contamination in the soil. Based on the 7-month operation of the SVE system, the ICE technology is an effective method of controlling vapor emissions and destroying contaminants. The SVE system reduced the volatile contaminant mass sufficiently to allow air injection bioventing operation to replace the more expensive SVE system. Therefore, SVE systems integrated with bioventing can be an effective and cost-efficient combination of treatment technologies.

The Air Force Center for Environmental Excellence (AFCEE) recommends that air injection be continued at the site until background respiration rates are approached. Soil gas sampling and additional respiration tests can be used as contaminant mass destruction indicators. The SVMW installed during this investigation (CP-11) should be monitored to ensure soil gas oxygen levels have increased in the area west of the fuel line as a result of extended air injection bioventing operations. Confirmatory soil sampling in support of site closure should be conducted four to six months after background respiration rates are achieved. A risk-based site closure is recommended which focuses on the removal of BTEX and its associated risk rather than on TPH residuals alone.

SECTION 4

REFERENCES

- CH2M Hill 1992, Draft Final Report, Capehart Service Station Site Investigation. April
- Downey, D.C., J.F. Hall, and R.N. Miller 1992, Bioventing in Low Permeable Soils, In: Proceedings of the NGWA Outdoor Action Conference, p. 599-612.
- Downey, D.C., R.A. Frishmuth, S.R. Archabal, C.J. Pluhar, P.G. Blystone, and R.N. Miller 1995, Using In Situ Bioventing to Minimize Soil Vapor Extraction Costs. In Situ Aeration: Air Sparging, Bioventing, and Related Remediation Processes (Battelle Press).
- Engineering-Science, Inc. 1994a, Draft Bioventing Pilot Test Work Plan Addendum for Capehart Gas Station Site (Building 5635), McClellan Air Force Base. January
- Engineering-Science, Inc. 1994b, Modification to Draft Bioventing Pilot Test Work Plan, Capehart Gas Station Site, McClellan AFB, California. Letter dated 14 March 1994.
- Hinchee, R.E. and A. Leeson 1995, Principles and Practices of Bioventing, Volume II: Bioventing Design, U.S. Air Force Center for Environmental Excellence (AFCEE). 29 September
- Hinchee et al. 1992, Test Plan and Technical Protocol for a Field Treatability Test for Bioventing, U.S. Air Force Center for Environmental Excellence (AFCEE). January
- Hinchee et al. 1994, Addendum One to Test Plan and Technical Protocol for a Field Treatability Test for Bioventing Using Soil Gas Surveys to Determine Bioventing Feasibility and Natural Attenuation Potential, U.S. Air Force Center for Environmental Excellence (AFCEE). February
- Parsons Engineering Science, Inc. 1995a, Annual Report of Compliance Source Tests, Capehart Gas Station, North Highlands, California. Letter dated 8 August 1995.
- Parsons Engineering Science, Inc. 1995b, A Draft Performance and Cost Evaluation of an Internal Combustion Engine for the Destruction of Hydrocarbon Vapors from Fuel-Contaminated Soils. November
- Phelps, M.B., F.T. Stanin, and D.C. Downey 1995, Long-Term Bioventing Performance in Low-Permeability Soils. In Situ Aeration: Air Sparging, Bioventing, and Related Remediation Processes (Battelle Press).

APPENDIX A

GEOLOGIC BORING LOGS

BORING NUMBER: VW-1

PROJECT NUMBER: 722406.36040	PROJECT NAME: McClellan Air Force Base
CLIENT: AFCEE	DRILLER: Beylik CME 95
LOCATION: Capehart Gas Station	DRILLING METHOD: HS 8 1/4 OD
	5 ft. continuous sampler, 18" SS
GEOLOGIST: H. Pietropaoli	HOLE DIAMETER: 8 1/4 enlarged to 10 1/2 (inches)
COMPLETION DATE: 5/18/94	TOTAL DEPTH: 105.7 feet below ground surface

DEPTH (feet)	SAMPLE LOCATION	SAMPLE NUMBER	BLOW COUNT	Soil Headspace PID/TVH (ppmv)	GRAPHIC LOG	SOIL CLASS	GEOLOGIC DESCRIPTION
0							6" Asphalt, roadrock
0 - 5			20 60 72	2,680/>10,000		ML	Light brown clayey SILT with interbedded light green silty CLAY (slight plasticity) damp to dry, silt - loose, iron staining throughout, fuel odor
5 - 10			30 100/6"	458/650		CL	Light brown silty CLAY with interbedded fine sand, micaceous, fuel odor
10 - 15			60 100/6"	NR/NR		SC	Silty CLAY, light brown, very hard, with mica, damp to dry, abundant iron staining, fuel odor
15 - 20			12 40 40	268/440		SW	Clayey SAND, light grey-brown, slightly plastic, damp, fuel odor, iron staining, organics, interbedded clay bed 4-6" at 12 and 13 feet bgs
20 - 25		CAP-VW1 -21.5				ML /CL	SAND, greenish grey, medium to coarse, moderate to well sorted, damp, loose, fuel odor
25 - 26.5		CAP-VW1 -21.5		130/200			Clayey SILT to silty CLAY, light grey, damp, slightly plastic, sweet fuel odor (At 23-24 ft bgs: medium-grain sand, greenish grey, fuel odor) (At 24 ft bgs: 3" zone of silty clay, white, crusty)
26.5 - 27		CAP-VW1 -26.5				SC	Clayey SAND, green brown, loose, slightly plastic, discolored
27 - 28						CL	

- First encountered groundwater.
- Brass tube sample submitted for laboratory analysis.
- Brass tube sample for field analysis
- Soil-gas sample submitted for laboratory analysis
- Soil-gas sample

BORING NUMBER: VW-1







PROJECT NUMBER: 722406.36040	PROJECT NAME: McClellan Air Force Base
CLIENT: AFCEE	DRILLER: Beylik CME 95
LOCATION: Capehart Gas Station	DRILLING METHOD: HS 8 1/4 OD
	5 ft. continuous sampler, 18" SS
GEOLOGIST: H. Pietropaoli	HOLE DIAMETER: 8 1/4 enlarged to 10 1/2 (inches)
COMPLETION DATE: 5/18/94	TOTAL DEPTH: 105.7 feet below ground surface



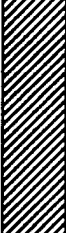

DEPTH (feet)	SAMPLE LOCATION	SAMPLE NUMBER	BLOW COUNT	Soil Headspace PID/TVH (ppmv)	GRAPHIC LOG	SOIL CLASS	GEOLOGIC DESCRIPTION
30			40 NR NR	8.8/186		CL	Silty CLAY to clayey SILT, light brown
						SM	SAND, grey to black, medium-grain, 3" layer
35			20 60 10/0"	4.7/25		CL	Silty CLAY, light brown, stiff, slightly plastic to plastic, damp to dry
40			20 21 22	2.8/85		SW	SAND, fine-grain, light brown, loose, damp to dry
45			16 60/0	18/20			Silty CLAY, light brown, stiff, slightly plastic, damp to dry, with 10% interbedded fine to medium sands from 40-44 ft bgs
50							Silty CLAY, light brown to reddish brown, slightly plastic, damp to moist, moderately stiff to stiff, with minor areas (< 10%) of fine sandy, silty, clay
55						SW	SAND, medium to coarse, 4-6" wide

- First encountered groundwater.
- Brass tube sample submitted for laboratory analysis.
- Brass tube sample for field analysis
- Soil-gas sample submitted for laboratory analysis
- Soil-gas sample

BORING NUMBER: VW-1



PROJECT NUMBER: 722406.36040	PROJECT NAME: McClellan Air Force Base
CLIENT: AFCEE	DRILLER: Beylik CME 95
LOCATION: Capehart Gas Station	DRILLING METHOD: HS 8 1/4 OD
	5 ft. continuous sampler, 18" SS
GEOLOGIST: H. Pietropaoli	HOLE DIAMETER: 8 1/4 enlarged to 10 1/2 (inches)
COMPLETION DATE: 5/18/94	TOTAL DEPTH: 105.7 feet below ground surface



DEPTH (feet)	SAMPLE LOCATION	SAMPLE NUMBER	BLOW COUNT	Soil Headspace PID/TVH (ppmv)	GRAPHIC LOG	SOIL CLASS	GEOLOGIC DESCRIPTION
60				26/40		CL	Silty CLAY, light brown, damp to moist, moderately stiff, with laminated fine sands. (At 63-64 ft bgs: zone of white streaks)
65				57/69			
70				17/40		SW	SAND, medium-grain, reddish brown, loose, damp
75				18/78		CH	CLAY, light brown-grey, moderately stiff, damp, plastic
80				18/40		CL	Silty CLAY, light brown-yellow, slightly plastic, damp, moderately stiff
85				22/70		ML	Clayey SILT, light brown, damp, slightly plastic, moderately stiff Silty CLAY, light brown, damp
						MH	SILT, light reddish brown, micaceous, damp
						CL	Silty CLAY, light brown-yellow, slightly plastic, damp, moderately stiff Silty CLAY, light brown

-  - First encountered groundwater.
-  - Brass tube sample submitted for laboratory analysis.
-  - Brass tube sample for field analysis
-  - Soil-gas sample submitted for laboratory analysis
-  - Soil-gas sample

BORING NUMBER: VW-1

PROJECT NUMBER: 722406.36040	PROJECT NAME: McClellan Air Force Base
CLIENT: AFCEE	DRILLER: Beylik CME 95
LOCATION: Capehart Gas Station	DRILLING METHOD: HS 8 1/4 OD
	5 ft. continuous sampler, 18" SS
GEOLOGIST: H. Pietropaoli	HOLE DIAMETER: 8 1/4 enlarged to 10 1/2 (inches)
COMPLETION DATE: 5/18/94	TOTAL DEPTH: 105.7 feet below ground surface

DEPTH (feet)	SAMPLE LOCATION	SAMPLE NUMBER	BLOW COUNT	Soil Headspace PFD/TVH (ppmv)	GRAPHIC LOG	SOIL CLASS	GEOLOGIC DESCRIPTION
90				42/100		CL	
95		CAP-VW2 -96 CAP-VW1 -96.5 <input checked="" type="checkbox"/> CAP-VW1 -97.5		2/6		ML	Clayey SILT, light brown, stiff to hard, slightly plastic, damp to moist (2% medium sand grains) grades downward into clayey silty medium sand, moist
100		CAP-VW2 -100.5 CAP-VW1 -101		47/150		▽	(No sampling between 101.5-106.5; this interval drilled with 10.5" OD HS)
105							
110							Base of borehole at 105.7' bgs

- ▽ - First encountered groundwater.
-  - Brass tube sample submitted for laboratory analysis.
-  - Brass tube sample for field analysis.
- Soil-gas sample submitted for laboratory analysis
- x - Soil-gas sample

BORING NUMBER: CP-8

PROJECT NUMBER: 722406.36060	PROJECT NAME: McClellan Air Force Base
CLIENT: AFCEE	
LOCATION: Capehart Gas Station	DRILLING METHOD: Geoprobe
GEOLOGIST: H. Pietropaoli	HOLE DIAMETER: 2 1/2 inches
COMPLETION DATE: 11/28/95	TOTAL DEPTH: 25.5 feet below ground surface

DEPTH (feet)	SAMPLE LOCATION	SAMPLE NUMBER	Soil Headspace PID/TVH (ppmv)	GRAPHIC LOG	SOIL CLASS	GEOLOGIC DESCRIPTION
0						10" Asphalt with underlying roadrock (gravel)
0 - 10			4.7/18		ML	Clayey SILT, light olive-green, trace coarse sand, moist to damp, slight plasticity, iron stained patches < 1/16"
5			3.0/8			As above
10			12.5/20		CL	Silty CLAY, light olive-green, damp to dry, slightly plastic, iron stained patches < 1/16"
15			10.5/60			As above
20			8.5/25		ML	Clayey SILT, light brown, micaceous, 1% organics, damp to dry, slightly plastic, stiff, (fine-grained sand on tip of sampler)
25		CAP-CP8-25.5	0.9/12			
						Total Depth 25.5' bgs

- - Contact.
- - Contact approximately located.
- ☒ - Soil-gas sample submitted for laboratory analysis.
- - High density polyethylene tube sample submitted for laboratory analysis.
- ⊠ - High density polyethylene tube sample used for field analysis.
- ✕ - Soil-gas sample.
- NR - Not Recorded.

BORING NUMBER: CP-9

PROJECT NUMBER: 722406.36060	PROJECT NAME: McClellan Air Force Base
CLIENT: AFCEE	
LOCATION: Capehart Gas Station	DRILLING METHOD: Geoprobe
GEOLOGIST: H. Pietropaoli	HOLE DIAMETER: 2 1/2 inches
COMPLETION DATE: 11/28/95	TOTAL DEPTH: 9.5 feet below ground surface

DEPTH (feet)	SAMPLE LOCATION	SAMPLE NUMBER	Soil Headspace PID/TVH (ppmv)	GRAPHIC LOG	SOIL CLASS	GEOLOGIC DESCRIPTION
0						10" Asphalt with underlying roadrock (gravel)
			NR/NR		ML	Gravelly SILT, light yellow-brown, damp, loose, (fill)
5			512/250		GP	Gravelly SAND, light yellow-brown, medium-grain, loose, fuel odor, damp, (fill)
10		CAP-CP9-9.5	4276/1500		CL	Silty CLAY, light gray-brown, damp, slightly plastic, hard, fuel odor
		CAP-CP9-10.5				Total Depth 9.5' bgs

- - Contact.
- - - - - Contact approximately located.
- High density polyethylene tube sample submitted for laboratory analysis.
- High density polyethylene tube sample used for field analysis
- Soil-gas sample submitted for laboratory analysis.
- X** - Soil-gas sample.
- NR** - Not Recorded.

BORING NUMBER: CP-10



PROJECT NUMBER: 722406.36060	PROJECT NAME: McClellan Air Force Base
CLIENT: AFCEE	
LOCATION: Capehart Gas Station	DRILLING METHOD: Geoprobe
GEOLOGIST: H. Pietropaoli	HOLE DIAMETER: 2 1/2 inches
COMPLETION DATE: 11/28/95	TOTAL DEPTH: 34 feet below ground surface

DEPTH (feet)	SAMPLE LOCATION	SAMPLE NUMBER	Soil Headspace PID/TVH (ppmv)	GRAPHIC LOG	SOIL CLASS	GEOLOGIC DESCRIPTION
0						Aphalt with underlying roadrock (gravel)
1.5			1.5/20		ML	Clayey SILT, light gray, damp, slightly plastic, stiff, micaceous, iron staining
5		211/75	As above, slight fuel odor			
10		2629/700	As above			
15		CAP-CP10-14 CAP-CP10-15	3791/2000 1859/700		SM	Silty SAND, mottled light gray-brown, fine-grained, loose, organics, iron staining, fuel odor, damp (Interbedded fine-grained sands and clays from 15-18.5' bgs).
20		4647/1800				
25			6.0/28		CL	Silty CLAY, light gray, slightly plastic, dry, fuel odor, iron staining, moderately stiff
			6.0/10			
					SM	SAND, light gray, fine-grained, loose, damp, moderately well-sorted

- - Contact.
- - Contact approximately located.
- High density polyethylene tube sample submitted for laboratory analysis.
- High density polyethylene tube sample used for field analysis
- Soil-gas sample submitted for laboratory analysis.
- Soil-gas sample.
- NR** - Not Recorded.

BORING NUMBER: CP-10

PROJECT NUMBER: 722406.36060	PROJECT NAME: McClellan Air Force Base
CLIENT: AFCEE	
LOCATION: Capehart Gas Station	DRILLING METHOD: Geoprobe
GEOLOGIST: H. Pietropaoli	HOLE DIAMETER: 2 1/2 inches
COMPLETION DATE: 11/28/95	TOTAL DEPTH: 34 feet below ground surface

DEPTH (feet)	SAMPLE LOCATION	SAMPLE NUMBER	Soil Headspace PID/TVH (ppmv)	GRAPHIC LOG	SOIL CLASS	GEOLOGIC DESCRIPTION
30	<input checked="" type="checkbox"/>	CAP-CP10-30				
		CAP-CP10-34	6.1/4.0		CL	Silty CLAY, light gray, stiff, hard, dry
35						Total Depth 34' bgs

- - Contact.
- - - - - Contact approximately located.
- Soil-gas sample submitted for laboratory analysis.
- High density polyethylene tube sample submitted for laboratory analysis. - Soil-gas sample.
- High density polyethylene tube sample used for field analysis **NR** - Not Recorded.

BORING NUMBER: CP-11

PROJECT NUMBER: 722406.36060	PROJECT NAME: McClellan Air Force Base
CLIENT: AFCEE	
LOCATION: Capehart Gas Station	DRILLING METHOD: Geoprobe
GEOLOGIST: H. Pietropaoli	HOLE DIAMETER: 2 1/2 inches
COMPLETION DATE: 11/29/95	TOTAL DEPTH: 29 feet below ground surface

DEPTH (feet)	SAMPLE LOCATION	SAMPLE NUMBER	Soil Headspace PID/TVH (ppmv)	GRAPHIC LOG	SOIL CLASS	GEOLOGIC DESCRIPTION
0						Aphalt with underlying roadrock (gravel)
0 - 10			0.5/10		ML	SILT, light gray, damp, iron staining, damp, micaceous, loose, friable
5			1.2/27			Silty CLAY with interbedded Clayey SILT, light gray, slightly plastic, iron staining, soft
10 - 15		CAP-CP11-10.5	7.3/5		SM	SAND to SILT, light gray brown, fine-grained, loose, damp, fuel odor, moderately well-sorted
15			2901/1200			(Interbedded clay 15-17.5' bgs).
15 - 20		CAP-CP11-17.5	40/139		CL	Silty CLAY, light gray, stiff, slight fuel odor, damp, slightly plastic
20			14.8/28			As above
20 - 25		CAP-CP11-26.5	4.4/30		CL	CLAY on tip of sampler, light gray-brown, stiff, hard
25						(drill refusal at 29' bgs) Total Depth 29' bgs
25 - 29		CAP-CP11-28				

- - Contact.
- - - - - Contact approximately located.
- High density polyethylene tube sample submitted for laboratory analysis.
- High density polyethylene tube sample for field analysis
- Soil-gas sample submitted for laboratory analysis.
- X** - Soil-gas sample.
- NR** - Not Recorded.

APPENDIX B

**O&M MANUAL AND
DATA COLLECTION SHEET**

**GENERIC BLOWER SYSTEM
OPERATIONS AND
MAINTENANCE MANUAL
FOR
EXTENDED PILOT TESTING
SYSTEM**

Prepared for:

**AIR FORCE CENTER FOR ENVIRONMENTAL EXCELLENCE
BROOKS AFB, TEXAS**

USAF CONTRACT F33615-90-D-4010, DELIVERY ORDER 14

April 1993

Prepared by:

**Engineering-Science, Inc.
1700 Broadway, Suite 900
Denver, Colorado**

CONTENTS

	<u>Page</u>
1.0 Introduction.....	1.1
2.0 Blower System Configuration Summary.....	2.1
3.0 Bioventing System Operation.....	3.1
3.1 Principle of Operation	3.1
3.2 System Description	3.1
3.2.1 Blower System.....	3.1
3.2.2 Monitoring Gauges	3.1
4.0 System Maintenance	4.1
4.1 Blower/Motor	4.1
4.2 Knock-Out Chamber	4.1
4.3 Air Filter.....	4.2
4.4 Maintenance Schedule	4.2
4.5 Major Repairs.....	4.2

FIGURES

<u>No.</u>	<u>Title</u>	<u>Page</u>
3.1	Typical Blower System Instrumentation Diagram for Air Injection/Extraction	3.2

APPENDIX A Regenerative Blower Information

APPENDIX B Rotary-Vane Blower Information

APPENDIX C Data Collection Sheets

SECTION 1

INTRODUCTION

This document has been prepared by Engineering-Science, Inc. to support the bioventing initiative contract awarded by the Air Force Center for Environmental Excellence. The contract involves the conducting of bioventing pilot tests at 35 sites on 23 Air Force bases across the United States.

At most sites, bioventing systems will be installed upon completion of the initial bioventing pilot tests for the purpose of extended pilot testing. These systems will operate for a 1-year period to provide further information as to the feasibility of the technology at each site, and to provide interim remedial action.

This Operations and Maintenance Manual has been created for sites at which regenerative or rotary-vane blowers have been installed for extended pilot testing. Basic maintenance of these systems is the responsibility of the Air Force facility. This manual is to be used by facility personnel to guide and assist them in operating and maintaining the blower system. Section 2 provides a summary of the bioventing system components installed. Section 3 of this document describes the blower system. Section 4 details the maintenance requirements and provides maintenance schedules. Section 5 describes the system monitoring that is required to forecast system maintenance needs and to provide data for the extended pilot test. Blower performance curves and relevant service information for regenerative and rotary-vane blowers are provided in Appendices A and B, respectively, and data collection sheets are provided in Appendix C.

SECTION 2

BLOWER SYSTEM CONFIGURATION SUMMARY

System Type (injection, extraction) injection
Blower (regenerative, rotary vane) regenerative
Blower Model R4110N-50
Motor (Hp) 1.0
Knock-Out Chamber (yes, no) No
Sampling Port (yes, no) No
Inlet Temperature Gauge (range) not installed
Inlet Pressure/Vacuum Gauge (range) 0-60 "H₂O
Inlet Filter (part no.) F-30P-150
Outlet Temperature Gauge (range) 0-250 °F
Outlet Pressure/Vacuum Gauge (range) 0-30 "H₂O
Pressure/Vacuum Relief Valve Set @ (give unit of measure) 45 "H₂O

SECTION 3

BIOVENTING SYSTEM OPERATION

3.1 PRINCIPLE OF OPERATION

Bioventing is the forced injection of fresh air, or withdrawal of soil gas, to enhance the supply of oxygen for *in situ* bioremediation. Either a pressure (air injection) or vacuum (vapor extraction) blower unit is used to inject or withdraw air into or from the soil, thereby supplying fresh air with 20.8 percent oxygen to the contaminated soils. Once oxygen is provided to the subsurface, existing bacteria will proceed with the breakdown of fuel residuals.

At Capehart Gas Station a air injection blower system has been installed.

3.2 SYSTEM DESCRIPTION

3.2.1 Blower System

A regenerative blower powered by a 1.0 horsepower direct-drive motor is the workhorse of the bioventing system. This blower is rated at a flow rate of 70 standard cubic feet per minute (scfm) at a pressure of 20" H₂O; however, the actual performance of the blower will vary with changing site conditions. As installed, the blower was producing an estimated flow rate of 25 scfm at a pressure of 8" H₂O*. Vapor extraction systems may include an inlet knockout chamber for water condensation. All systems include an air filter to remove any particulates which are entrained in the air stream, and several valves and monitoring gauges which are described in the next section. A schematic of the blower system installed at _____ is shown on Figure 3.1. Corresponding blower performance curves, and relevant service information are provided in Appendices A and B.

3.2.2 Monitoring Gauges

The bioventing system is equipped with vacuum and pressure gauges, temperature gauges, and a sampling port (vapor extraction only). Generally, gauges have been installed on the air injection system at the following locations: a vacuum gauge in the inlet piping and a pressure gauge in the outlet piping. For vapor extraction systems gauges are generally installed as follows: vacuum gauges in the

* Flow rate given is the actual flow rate into the well. Some of the total air flow from the blower is being routed through the air bleed valve/flow

A7-1-73
Control Valve

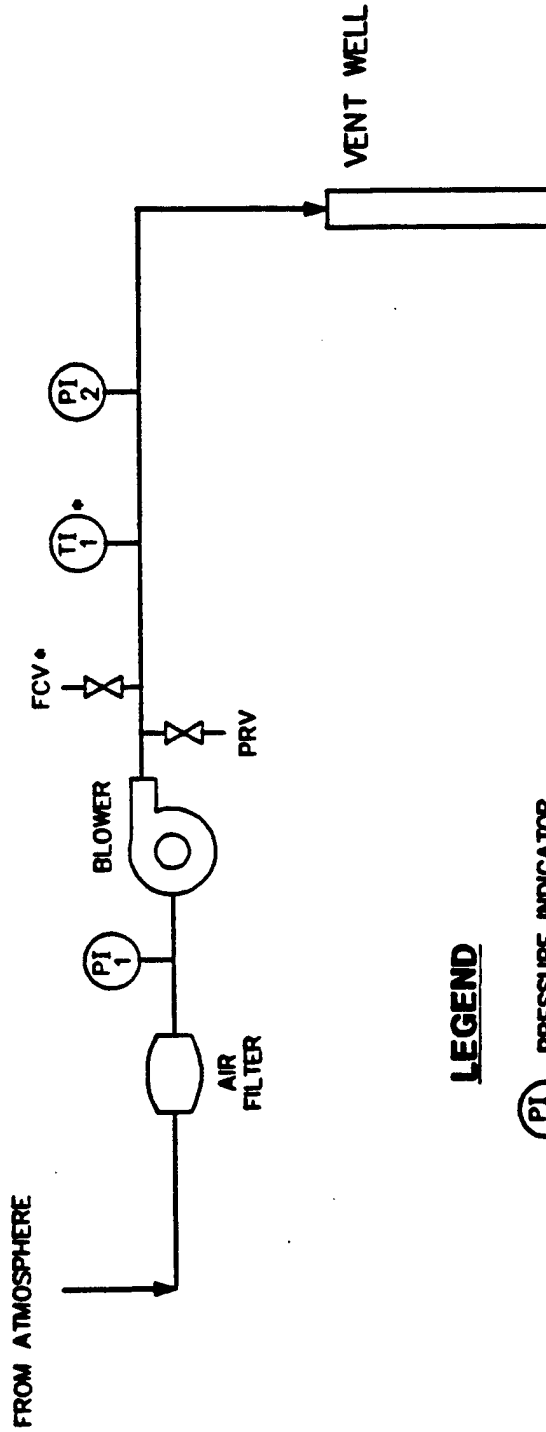

LEGEND



-  PRESSURE INDICATOR
-  TEMPERATURE INDICATOR
- FCV FLOW CONTROL VALVE
- PRV PRESSURE RELIEF VALVE
- OPTIONAL

FIGURE 3.1

**TYPICAL BLOWER SYSTEM
INSTRUMENTATION DIAGRAM
FOR AIR INJECTION**

ENGINEERING-SCIENCE, INC.
Denver, Colorado



inlet piping and at the knock-out chamber (as applicable), and a pressure gauge in the discharge piping. See Figure 3.1 for the locations of the gauges installed on the blower system at this site.

Temperature gauges may be located at the inlet and outlet of the blower system. These gauges are used to monitor the inlet and outlet temperature to determine the change in temperature across the blower. For air injection systems, ambient air temperature should be used when an inlet temperature gauge is not present. For vapor extraction systems, the inlet temperature is also used as an estimate of soil gas temperatures in the contaminated soil zone. See Figure 3.1 for the location(s) of the temperature gauges installed on the blower system at this site.

A sample port is located in the discharge piping on the outlet side of vapor extraction systems only. This sample port is used to collect offgas that is analyzed for carbon dioxide/oxygen and volatile organic compound concentrations. See Figure 3.1 for the location of the sampling port installed on the blower system at this site.

SECTION 4

SYSTEM MAINTENANCE

Although the motor and blower are relatively maintenance free, periodic system maintenance is required for proper operation and long life. Recommended maintenance procedures and schedules are described in detail in the instruction manuals included in Appendices A and B and briefly summarized in this section.

Filter inspection and knock-out chamber draining (as applicable) must be performed with the system turned off. To re-start the motor, ~~open the manual air dilution valve (red handle) to protect the motor from excessive strain, start motor, and slowly close dilution valve. If the handle has been removed from the manual air dilution valve,~~ do not open the valve or otherwise change the setting (it has been pre-set for a specific flow rate) before re-starting the blower. *NA*

4.1 Blower/Motor

The blower and motor are relatively maintenance free and should not require any periodic maintenance during the 1-year extended testing period. Both blower and motor have sealed bearings and do not require lubrication.

4.2 KNOCK-OUT CHAMBER

This section applies only to vapor extraction systems equipped with moisture knock-out chamber. To avoid damage caused by passing liquids solids through the blower a knock-out chamber has been installed in-line before the blower.

Free liquid should not be pumped through the blower. The knock-out chamber installed in-line before the blower intercepts entrained liquid, preventing damage to the blower. The knock-out chamber should be drained into an appropriate container once a month for the first few months and at less frequent intervals thereafter, if it appears that this will be sufficient to keep liquid from building up in the knock-out chamber. Condensation generally increases during the cold winter months. A facility employee should determine the best schedule for draining the knock-out chamber. The knock-out chamber can be drained by turning the system off and removing the cap or opening the valve at the base of the knock-out chamber. When all of the liquid has drained out, the system can be turned back on. It is recommended when re-starting the system that the air dilution valve (red-handled valve) be opened to protect the motor from excessive strain. If oily, drained liquids should be disposed of in an oil/water separator.

4.3 AIR FILTER

To avoid damage caused by passing solids through the blower, an air filter has been installed in-line before the blower. The filter element is paper and is accompanied by a polyurethane foam prefilter. The filter should be checked weekly for the first 2 months of operation. Again, a facility employee should determine the best schedule for filter replacement. The polyurethane prefilters can be washed with lukewarm water and a mild detergent. Paper filter elements should never be washed, but should be disposed of and replaced as necessary. When the pressure or vacuum drop across the filter is above 15 inches of water, a dirty filter element should be suspected, and cleaning or replacement should be performed.

To remove the filter, loosen the three clamps or the wing nut, lift the metal top off the air filter, and lift the air filter from the metal housing. Remove the polyurethane prefilter (if applicable) and wash before replacing. When replacing the filter, be careful that the rubber seals remain in place.

The filter element is manufactured by Solberg Manufacturing, Inc. in Itasca, Illinois. Their telephone number is (708) 773-1363. Additional filters can also be obtained through Engineering-Science, Inc. in Denver, Colorado. The ES contacts are Mr. ~~Brian Bliker~~ and Craig Snyder and they can be reached at (303) 831-8100. The filter model number is F-30P-150, and the number for the replacement element is F-30P-150. It is recommended that McClellan EM office keep at least one spare air filter at the site, four spare filters were supplied with the blower system.

4.4 MAINTENANCE SCHEDULE

The following maintenance schedule is recommended for this system. During the initial months of operation more frequent monitoring is recommended to ensure that any startup problems are quickly corrected. A daily drive-by inspection is recommended during the initial 2 weeks of operation to ensure that the blower system is still operating with no unusual sounds. Data collection sheets that can be used to record maintenance activities are included in Appendix C.

<u>Maintenance Item</u>	<u>Maintenance Frequency</u>
Filter	Check once per month, wash or replace as necessary (see Section 4.3).
Knock-out chamber	Drain once per month initially, then periodically (see Section 4.2).

4.5 MAJOR REPAIRS

Blowers systems are very reliable when properly maintained. Occasionally, a motor or blower will develop a serious problem. If a blower system fails to start, and a qualified electrician verifies that power is available at the blower or starter,

the Engineering-Science, Inc. site manager Michael Phelps should be called at (510) 769-0100. ES is responsible for major repairs during the first year of operation.

SECTION 5

SYSTEM MONITORING

5.1 BLOWER PERFORMANCE MONITORING

To monitor the blower performance, vacuum, pressure, and temperature will be measured. These data should be recorded weekly on a data collection sheet (provided in Appendix C). All measurements should be taken at the same time while the system is running. Because the system is loud, hearing protection should be worn at all times.

5.1.1 Vacuum/Pressure

With hearing protection in place, open the blower enclosure and record all vacuum and pressure readings directly from the gauges (in inches of water or psi). Record the measurements on a data collection sheet (Appendix C).

5.1.2 Flow Rate

The flow rate through the vent well and soils can be calculated when the inlet vacuum and outlet pressure of the blower are known. This pressure change across the blower (vacuum + pressure) can be compared to the performance curves for the blower in Appendix A or Appendix B to determine the approximate flow rate.

5.1.3 Temperature

With hearing protection in place, open the blower enclosure and record the temperature readings directly from the gauges in degrees Fahrenheit (°F). Record the measurements on a data collection sheet (provided in Appendix C). The temperature change can be converted to degrees Celsius (°C) using the formula $^{\circ}\text{C} = (^{\circ}\text{F} - 32) \times 5/9$.

5.3 MONITORING SCHEDULE

The following monitoring schedule is recommended for this system. During the initial months of operation, more frequent monitoring is recommended to ensure that any start up problems are quickly corrected. Data collection sheets have been provided to assist your data collection and are included in Appendix C.

Monitoring Item

Monitoring Frequency

Vacuum/Pressure

Daily during first week, then once per week.

Temperature

Daily during first week, then once per week.

APPENDIX A
REGENERATIVE BLOWER INFORMATION



Post Office Box 97
Benton Harbor, Michigan 49023-0097
Ph: 616/926-6171
Fax: 616/925-8288

Maintenance Instructions for Gast Standard Regenerative Blowers

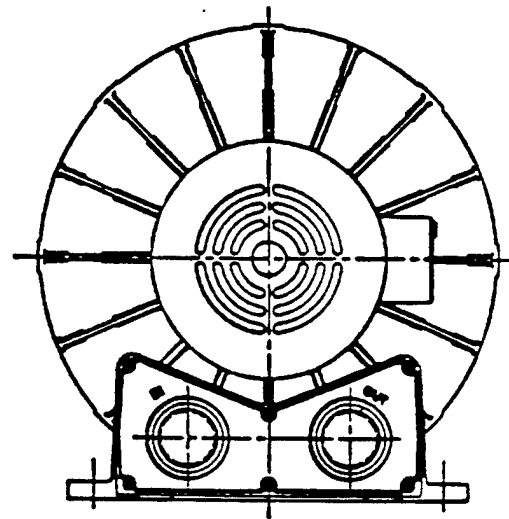
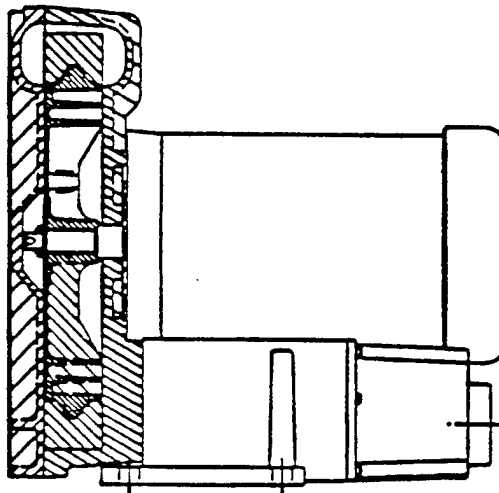

For original equipment manufacturers
special models, consult your local distributor

Gast Rebuilding Centers

Gast Mfg. Corp.
2550 Meadowbrook Rd.
Benton Harbor MI. 49022
Ph: 616/926-6171
Fax: 616/925-8288

Gast Mfg Corp.
505 Washington Avenue
Carlstadt, N. J. 07072
Ph: 201/933-8484
Fax: 201/933-5545

Brenner Fiedler & Assoc.
13824 Bentley Place
Cerritos, CA. 90701
Ph: 213/404-2721
Fax: 213/404-7975

Wainbee, Limited
121 City View Drive
Toronto, Ont. Canada M9W 5A9
Ph: 416/243-1900
Fax: 416/243-2336

Wainbee, Limited
215 Brunswick Drive
Pointe Claire, P.Q. Canada H9R 4R7
Ph: 514/697-8810
Fax: 514/697-3070

Gast Mfg. Co. Limited.
Halfax Rd, Cressex Estate
High Wycombe, Bucks HP12 3SN
Ph. 44 494 523571
Fax: 44 494 436588

Japan Machinery Co. Ltd.
Central PO Box 1451
Tokyo 100-91 Japan
Ph: 813/3573-5421
Fax: 813/3571-7865

Regenerative Blowers For Soil Remediation to 260 cfm

(5-91)



R4, R5, R6P Series

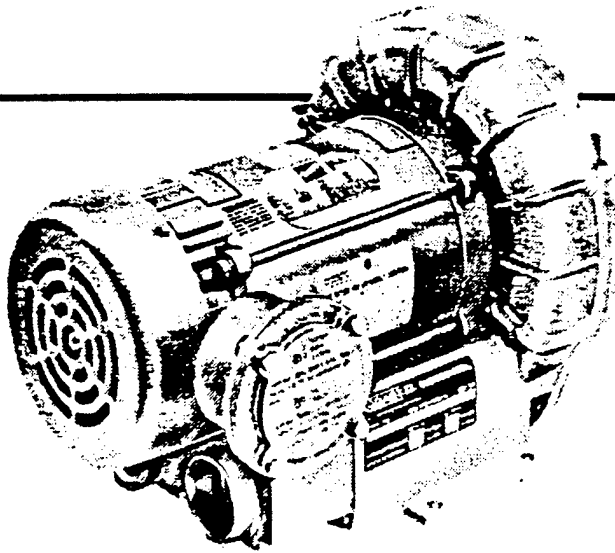

MODEL R4 SERIES
48" H₂O MAX. VAC., 88 CFM OPEN FLOW

MODEL R5 SERIES
60" H₂O MAX. VAC., 145 CFM OPEN FLOW

MODEL R6P SERIES
90" H₂O MAX. VAC., 260 CFM OPEN FLOW

PRODUCT FEATURES

- Explosion-proof motors UL (class 1, group D; class 2, groups F & G)
- Sealed air stream
- Rugged construction
- Low maintenance

RECOMMENDED ACCESSORIES

- Inlet filter AJ151G
(Reducing filter plumbing from 2½" to 1½" is needed to accommodate filter on R4 and R5 models.)
- Relief valve AG258
- Vacuum gauge AE134

Product Dimensions Metric (mm) U.S. Imperial (Inches)

Model	A	B	C	D	E	F	G	H	I	J	K	L	M	N	O
R4110N-50	157	43	360	95	72	316	313	50	101	225	227	254	293	175	11
	6.18	1.68	14.16	3.75	2.85	12.44	12.31	1.98	3.96	8.86	8.93	10.00	11.73	6.88	.44
R4310P-50	157	43	360	95	72	316	313	50	101	225	227	254	293	175	11
	6.18	1.68	14.17	3.75	2.84	12.44	12.31	1.98	3.96	8.86	8.93	10.00	11.73	6.88	.44
R5325R-50	178	46	423	114	91	361	344	60	121	260	262	298	350	183	15
	7.00	1.82	16.66	4.50	3.58	14.22	13.56	2.38	4.75	10.25	10.31	11.75	13.78	7.19	.59
R6P355R-50	248	80	482	140	137	438	428	64	127	-	290	325	463	257	13
	9.77	3.15	18.98	5.51	5.39	17.25	16.87	2.50	5.00	-	11.42	12.80	18.21	10.12	.50

Model R4 Series
Model R5 Series

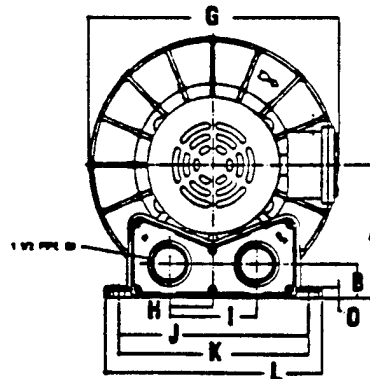
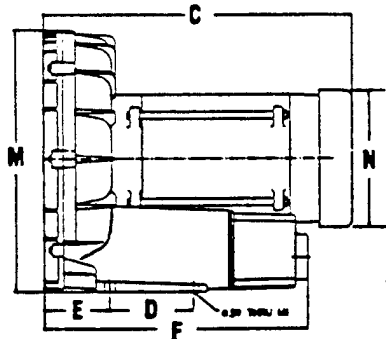

Model R6P Series

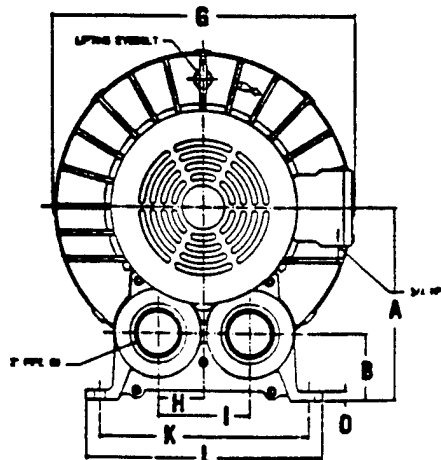
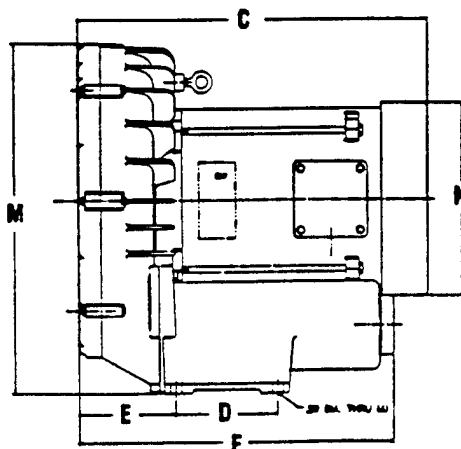

NOTE: These units with explosion-proof motors are designed specifically for qualified OEMs in the soil remediation industry. They are not intended to be applied for other uses without written acknowledgement from an authorized employee of Gast Manufacturing Corporation.

1st Q

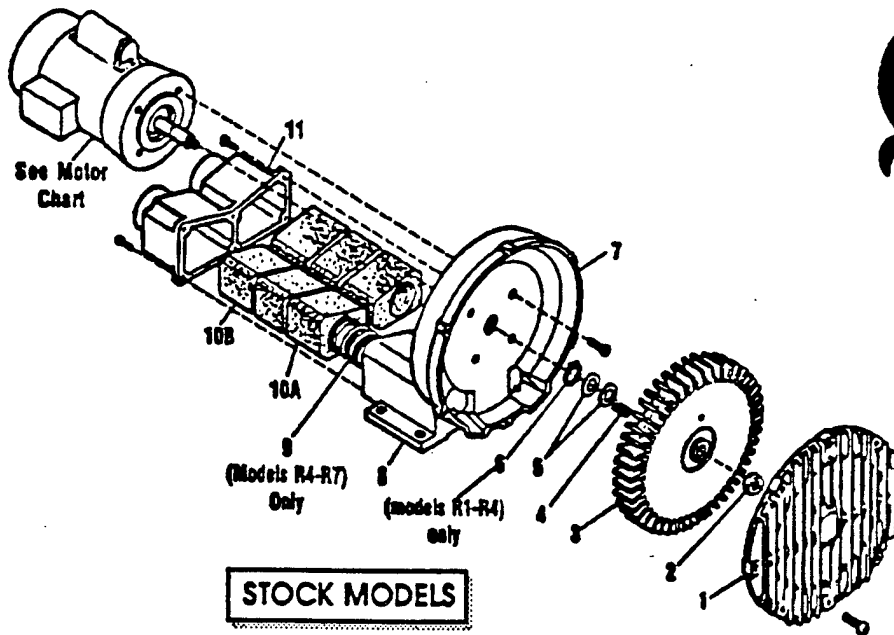

STOCK MODELS

Part Name	R1	R2	R3	R4	R5	R6	R6P	R6PP/R6PS	R7
#1 Cover	AJ101A	AJ101B	AJ101C	AJ101D	AJ101EQ	AJ101F	AJ101K	(2)AJ101KA	AJ101G
#2 Stopnut	BC187	BC187	BC181	BC181	BC181	BC181	BC181	(2)BC182	BC183
#3 Impeller	AJ102A	AJ102BQ	AJ102C	AJ102D	AJ102E	AJ102FR	AJ102K	(2)AJ102KA	AJ102GA
#4 Square Key	AH212C	AH212	AB136A	AB136D	AB136	AB136	AB136	(2)AB136	AC628
#5 Shim Spacer (s)	AJ132	AE686-3	AJ109	AJ109	AJ109	AJ109	AJ116A	AJ116A	AJ110
#6 Retaining Ring	AJ145	AJ145	AJ149	AJ149					
#7 Housing	AJ103A	AJ103BQ	AJ103C	AJ103DR	AJ103E	AJ103F	AJ103K	AJ103KD	AJ103GA
#8 Muffler Box					AJ104E	AJ104F			
#9 Spring				AJ113DR	AJ113DQ	AJ113FQ	AJ113FQ		AJ113G
#10A Foam	(4)AJ112A	(4)AJ112B	(4)AJ112C	(4)AJ112DS	(4)AJ112ER	(6)AJ112F	(8)AJ112K		(8)AJ112GA
#10B Foam		(2)AJ112BQ	(2)AJ112CQ	(2)AJ112DR	(2)AJ112EQ				
#11 Muffler Extension/ Adaptor Plate	AJ106H	AJ106BQ	AJ106CQ	AJ106DQ	AJ106EQ	AJ106EQ	AJ104K		AJ104GA
Shim Kit	K396	K396							K395

MOTOR CHART

REGENAIR MODEL NUMBER	MOTOR NUMBER	MOTOR SPECIFICATIONS		PHASE
		60 HZ VOLTS	50 HZ VOLTS	
R1102	J111X	115/208-230	110/220-240	1
R1102C	J112X	115		1
R2103	J311X	115/208-230	110/220	1
R2105	J411X	115/208-230	110/220	1
R2303A	J310	208-230/460	220/380-415	3
R2303F	J313	208-230	220	3
R3105-1/R3105-12	J411X	115/208-230	110/220-240	1
R3305A-1/R3305A-13	J410	208-230/460	220/380-415	3
R4110-2	J611AX	115/208-230	110/220-240	1
R4310A-2	J610	208-230/460	220/380-415	3
R5125-2	J811X	115/208-230		1
R5325A-2	J810X	208-230/460	220/380-415	3
R6125-2	J811X	115/208-230		1
R6325A-2	J810X	208-230/460	220/380-415	3
R6335A-2	J910X	208-230/460	220/380-415	3
R6150J-2	J1013	230		1
R6350A-2	J1010	208-230/460	220/380-415	3
R6P335A	J910X	208-230/460	220/380-415	3
R6P350A	J1010	208-230/460	220/380-415	3
R6P355A	J110A	208-230/460	220/380-415	3
R7100A-2*	J1210B	208-230/460	220/380-415	3
R6PP/R6PS3110M	JD1100	208-230/460	220/380-415	3

* No lubrication needed at start up. Bearings lubricated at factory.

* Motor is equipped with alemite fitting. Clean tip of fitting and apply grease gun. Use 1 to 2 strokes of high quality ball bearing grease.

Consistency	Type	Typical Grease
Medium	Lithium	Shell Dolium R

Hours of service per year	Suggested ReLube Interval
5,000	3 years
Continual Normal Application	1 year
Seasonal service motor idle for 6 months or more	1 year beginning of season 6 months

Continuous-high ambient, dirty or moist applications.

60 HZ FLOW DATA (CFM)

All performance figures relate to stock models. A few high pressure units may be available. Consult your local distributor.

Regenair Model Number	P R E S S U R E						Maximum Pressure "H ₂ O"
	0"H ₂ O	20"H ₂ O	40"H ₂ O	60"H ₂ O	80"H ₂ O	100"H ₂ O	
R1	26	14					28
R2	42	26					38
R3105-1	52	38	14				42
R3105-12	52	36	23				55
R3305A-13	52	36	23				55
R4	90	70	50				52
R5	145	130	100				65
R6125-2	200	180					35
R6325A-2	200	180	152				40
R6335A-2	205	175	155	135			70
R6350A-2	200	180	150	130	110	80	105
R6P335A	290	250					30
R6P350A	300	260	230	200			60
R6P355A	300	260	230	200	160		90
R7100A-2	420	380	340	310	280	230	115
R6PP311OM	485	452	420	380	330		95
R6PS311OM	265	258	252	244	236	226	170

Regenair Model Number	V A C U U M					Maximum Vacuum "H ₂ O"
	0"H ₂ O	20"H ₂ O	40"H ₂ O	60"H ₂ O	80"H ₂ O	
R1	25	14				26
R2	40	22				34
R3105-1	50	34	9			40
R3105-12	51	34	20			50
R3305A-13	51	34	20			50
R4	82	62	39			48
R5	140	115	90	50		60
R6125-2	190	155	125			45
R6325A-2	190	155	125			45
R6335A-2	190	150	125	100		75
R6350A-2	190	180	150	100	70	90
R6P335A	270	230				37
R6P350A	280	240	210	170		70
R6P355A	280	240	210	170	100	86
R7100A-2	410	350	300	250	170	90
R6PP311OM	470	425	375	320	220	80
R6PS311OM	240	225	210	195	175	130

*This number indicates the maximum static pressure differential recommended (with cooling air still flowing through unit). In general, units 1hp or less can be dead headed. Check with local representative or distributor to verify which models apply.

Operation of the blower above the recommended maximum duty will cause premature failure due to the build up of heat damaging the components.

Performance data was determined under the following conditions:

- 1) Unit in a temperature stable condition.
- 2) Test conditions: Inlet air density at 0.075lbs. per cubic foot. (20°C(68°F), 29.92 in. Hg(14.7PSIA)).
- 3) Normal performance variations on the resistance curve within +/- 10% of supplied data can be expected.
- 4) Specifications subject to change without notice.
- 5) All performance at 60Hz operation.



Post Office Box 97
Benton Harbor, MI. 49023-0097
Ph: 616/926-6171
Fax: 616/925-8288

70-6100
F2-205/8/92
AK811 Rev. E

INSTALLATION AND OPERATING INSTRUCTIONS FOR GAST HAZARDOUS DUTY REGENAIR BLOWERS

**This instruction applies to the following
models ONLY: R3105N-50, R4110N-50,
R4310P-50, R4P115N-50, R5125Q-50,
R5325R-50, R6130Q-50, R6P155Q-50,
R6350R-50, R6P355R-50 and R7100R-50.**

Gast Authorized Service Facilities are Located in the locations listed below

Gast Manufacturing Corporation
605 Washington Avenue
Carlstadt, N. J. 07072
Ph: 201/933-8484
Fax: 201/933-5545

Gast Manufacturing Corporation
2550 Meadowbrook Road
Benton Harbor, MI. 49022
Ph: 616/926-6171
Fax: 616/925-8288

Brenner Fiedler & Associates
13824 Bentley Place
Cerritos, CA. 90701
Ph: 213/404-2721
Ph: 800/843-5558
Fax: 213/404-7975

Wainbee Limited
215 Brunswick Blvd.
Pointe Claire, Quebec
Canada H9R 4R7
Ph: 514/697-8810
Fax: 514/697-3070

Wainbee Limited
5789 Coopers Ave.
Mississauga, Ontario
Canada L4Z 3S6
Ph: 416/243-1900
Fax: 416/243-2336

Japan Machinery
Central PO Box 1451
Toyko 100-91, Japan
Ph: 813 3573-5421
Fax: 813 3571-7896

Gast Manufacturing Co. Ltd.
Haltax Road, Cressex Estate
High Wycombe, Bucks HP12 3SN
England
Ph: 44 494 523571
Fax: 44 494 436588

Safety

- ⚠ This is the safety alert symbol. When you see this symbol, personal injury is possible. The degree of injury is shown by the following signal words:
- ⚠ **DANGER:** Severe injury or death will occur if hazard is ignored.
- ⚠ **WARNING:** Severe injury or death can occur if hazard is ignored.
- ⚠ **CAUTION:** Minor injury or property damage can occur if hazard is ignored.

Review the following information carefully before operating.

General Information

- ⚠ **DANGER:** Do not pump flammable or explosive gases or operate in an atmosphere containing them. Ambient temperature for normal operation should not exceed 40 degrees C (105 degrees F). For higher ambient operation, consult the factory. Blower performance is reduced by the lower atmospheric pressure of high altitudes. If it applies to this unit, consult a Gast distributor or the factory for details.

Installation

- ⚠ **WARNING:** Electric Shock can result from bad wiring. Wiring must conform to all required safety codes and be installed by a qualified person. Grounding is required.

The Gast Regenair blower can be installed in any position. The flow of cooling air over the blower and motor must not be blocked.

PLUMBING - The threaded pipe ports are designed as connection ports only and will not support the plumbing. Be sure to use the same or larger size pipe and fittings to prevent air flow restriction and over-heating of the blower. When installing plumbing, be sure to use a small amount of pipe thread lubricant. This protects the threads in the aluminum blower housing. Dirt and chips, often found in new plumbing, should not be allowed to enter the blower.

NOISE - To reduce noise and vibration, the unit should be mounted on a solid surface that will not increase sound. The use of shock mounts or vibration isolation material is recommended. If needed, inlet or discharge noise can be reduced by attaching muffler assemblies (see accessories).

ROTATION - The Gast Regenair blower should only rotate clockwise as viewed from the electric motor side. This is marked with an arrow in the casting. Proper rotation can be confirmed by checking air flow at the IN and OUT ports. On blowers powered by a three phase motor, rotation is reversed by changing any two of the three power wires.

Operation

- ⚠ **WARNING:** Solid or liquid material exiting the blower or piping can cause eye damage or skin cuts. Keep away from air stream.
- ⚠ **CAUTION:** Attach blower to solid surface before starting. Prevent injury or damage from unit movement. Air containing solid particles or liquid must pass through a filter before entering the blower (see accessories list for filter suggestions). Blowers must have mufflers, filters, other accessories and all piping attached before starting. Any foreign material passing through the blower may cause internal damage.
- ⚠ **CAUTION:** Outlet piping can burn skin. Guard or limit access. Mark "CAUTION Hot surface. Can cause burns."

Air temperature increases when passing through the blower. When run at duties above 50 in. H₂O, metal pipe may be required for hot exhaust air.

The blower must not be operated above the limits for continuous duty. "Standard" R1, R2, R3 and R4 can operate continuously with not air flowing through the blower. Other units can only be run at the rating shown on the model number label. Do not close off inlet (for vacuum) or exhaust (for pressure) to reduce extra air flow. This could cause added heat and motor load.

ACCESSORIES - Gast pressure gauges AJ496 or AE133 and vacuum gauges AJ497 or AE134 show blower duty. The Gast pressure/vacuum relief valve, AG258, will limit the operating duty by admitting or relieving air. It also allows full flow through the blower when the relief valve closes.

Service

- ⚠ **WARNING:** Disconnect electric power before servicing. Be sure rotating parts have stopped. Electric shock or severe cuts can result. Inlet and exhaust filters need occasional cleaning or replacement of the elements. Failure to do so will result in more pressure drop, reduced air flow and hotter operation. The outside of the unit requires cleaning of dust and dirt. The inside of the blower also may need cleaning to remove material coating the impeller and housing. If not done, the buildup can cause vibration, hotter operation and reduced flow. Noise absorbing foam in the mufflers may need replacement.
- KEEP THIS INFORMATION WITH THE BLOWER. REFER TO IT FOR SAFE INSTALLATION, OPERATION OR SERVICE.

Symptom	TROUBLESHOOTING	
	Possible Diagnosis	Possible Remedy
Excess Vibration	Impeller damaged by foreign material Impeller contaminated by foreign material	Replace impeller Clean impeller, install adequate filtration.
Abnormal sound	Motor bearing failed Impeller rubbing against cover or housing	Replace bearings Repair Blower, check clearances.
Increase in sound	Foreign material can coat or destroy muffler foam.	Replace foam muffler elements, trap or filter foreign material.
Blown fuse	Electrical wiring problem	Have qualified person check fuse capacity and wiring.
Unit very hot	Running at too high a pressure or vacuum	Install a relief valve

OPERATING AND MAINTENANCE INSTRUCTIONS

SAFETY

This is the safety alert symbol. When you see this symbol personal injury is possible. The degree of injury is shown by the following signal words:

DANGER Severe injury or death will occur if hazard is ignored.

WARNING Severe injury or death can occur if hazard is ignored.

CAUTION Minor injury or property damage can occur if hazard is ignored.

Review the following information carefully before operating.

GENERAL INFORMATION

This instruction applies to the following models ONLY: R3105N-50, R4110N-50, R4310P-50, R4P115N-50, R5125Q-50, R5325R-50, R6130Q-50, R6P155Q-50, R6350R-50, R6P355R-50 and R7100R-50. These blowers are intended for use in Soil Vapor Extraction Systems. The blowers are sealed at the factory for very low leakage. They are powered with a U.L. listed electric motor Class 1 Div. 1 Group D motors for Hazardous Duty locations. Ambient temperature for normal full load operation should not exceed 40° C (105° F). For higher ambient operation, contact the factory.

Gast Manufacturing Corporation may offer general application guidance: however, suitability of the particular blower and/or accessories is ultimately the responsibility of the user, not the manufacturer of the blower.

INSTALLATION

DANGER Models R5325R-50, R6130Q-50, R6350R-50, R5125Q-50, R6P155Q-50, R6P355R-50 AND R7100R-50 use Pilot Duty Thermal Overload Protection. Connecting this protection to the proper control circuitry is mandated by UL674 and NEC501. Failure to do so could/ may result in a **EXPLOSION**. See pages 3 and 4 for recommended wiring schematic for these models.

WARNING Electric shock can result from bad wiring. A qualified person must install all wiring, conforming to all required safety codes. Grounding is necessary.

WARNING This blower is intended for use on soil vapor extraction equipment. Any other use must be approved in writing by Gast Manufacturing Corp. Install this blower in any mounting position. Do not block the flow of cooling air over the blower and motor.

PLUMBING - Use the threaded pipe ports for connection only. They will not support the plumbing. Be sure to use the same or larger size pipe to prevent air flow restriction and overheating of the blower. When installing fittings, be sure to use pipe thread sealant. This protects the threads in the blower housing and prevents leakage. Dirt and chips are often found in new plumbing. Do not allow them to enter the blower.

NOISE - Mount the unit on a solid surface that will not increase the sound. This will reduce noise and vibration. We suggest the use of shock mounts or vibration isolation material for mounting.

ROTATION - The Gast Regenair Blower should only rotate clockwise as viewed from the electric motor side. The casting has an arrow showing the correct direction. Confirm the proper rotation by checking air flow at the IN and OUT ports. If needed reverse rotation of three phase motors by changing the position of any two of the power line wires.

OPERATION

WARNING Solid or liquid material exiting the blower or piping can cause eye damage or skin cuts. Keep away from air stream.

WARNING - Gast Manufacturing Corporation will not knowingly specify, design or build any blower for installation in a hazardous, combustible or explosive location without a motor conforming to the proper NEMA or U. L. standards. Blowers with standard TEFC motors should never be utilized for soil vapor extraction applications or where local state and/or Federal codes specify the use of explosion-proof motors (as defined by the National Electric Code, Articles 100,500 c1990).

CAUTION Attach blower to solid surface before starting to prevent injury or damage from unit movement. Air containing solid particles or liquid must pass through a filter before entering the blower. Blowers must have filters, other accessories and all piping attached before starting. Any foreign material passing through the blower may cause internal damage to the blower.

CAUTION Outlet piping can burn skin. Guard or limit access. Mark "CAUTION Hot Surface. Can Cause Burns". Air temperature increases when passing through the blower. When run at duties above 50 in. H₂O, metal pipe may be required for hot exhaust air. The blower must not be operated above the limits for continuous duty. Only models R3105N-50, R4110N-50 and R4310P-50 can be operated continuously with no air flowing through the blower. Other units can only be run at the rating shown on the model number label. Do not Close off inlet (for vacuum) to reduce extra air flow. This will cause added heat and motor load. Blower exhaust air in excess of 230°F indicates operation in excess of rating which can cause the blower to fail.

ACCESSORIES - Gast pressure gauge AJ496 and vacuum gauges AJ497 or AE134 show blower duty. The Gast pressure/vacuum relief valve, AG258, will limit the operating duty by admitting or relieving air. It also allows full flow through the blower when the relief valve closes.

SERVICING

⚠ WARNING To retain their sealed construction they should be serviced by Gast authorized service centers ONLY. These models are sealed at the factory for very low leakage.

⚠ WARNING Turn off electric power before removing blower from service. Be sure rotating parts have stopped. Electric shock or severe cuts can result. Inlet and exhaust filters attached to the blower may need cleaning or replacement of the elements. Failure to do so will result in more pressure drop, reduced air flow and hotter operation of the blower.

The outside of the unit requires cleaning of dust and dirt. The inside of the blower also may need cleaning to remove foreign material coating the impeller and housing. This should be done at a Gast Authorized Service Center. This buildup can cause vibration, failure of the motor to operate or reduced flow.

KEEP THIS INFORMATION WITH THIS BLOWER. REFER TO IT FOR SAFE INSTALLATION, OPERATION OR SERVICE.

MOTOR WIRING DIAGRAM FOR R4110N-50 & R3105N-50

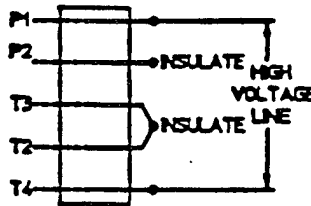
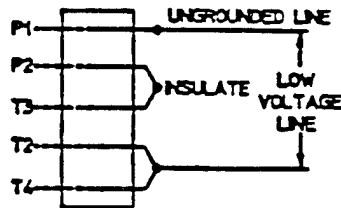

⚠ WARNING
THIS MOTOR IS THERMALLY PROTECTED AND WILL AUTOMATICALLY RESTART WHEN PROTECTOR RESETS. ALWAYS DISCONNECT POWER SUPPLY BEFORE SERVICING.

MOTORS WIRING DIAGRAM FOR R4310P-50

TO REVERSE ROTATION, INTERCHANGE THE EXTERNAL CONNECTIONS TO ANY TWO LEADS.

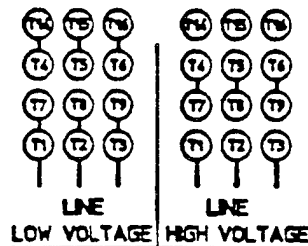

⚠ WARNING
THIS MOTOR IS THERMALLY PROTECTED AND WILL AUTOMATICALLY RESTART WHEN PROTECTOR RESETS. ALWAYS DISCONNECT POWER SUPPLY BEFORE SERVICING.

MOTORS WIRING DIAGRAM FOR R5325R-50, R6350R-50, R6P355R-50, & R7100R-50

TO REVERSE ROTATION, INTERCHANGE THE EXTERNAL CONNECTIONS TO ANY TWO LEADS.

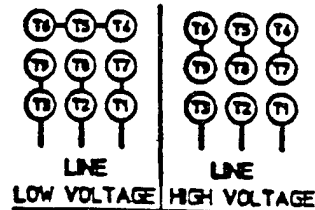
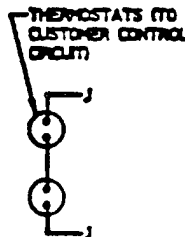

MOTOR WIRING DIAGRAM FOR R5125Q-50 & R4P115N-50

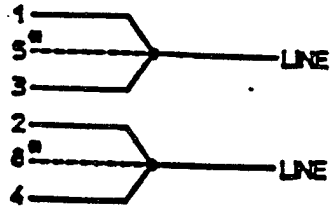

— THERMOSTAT
— THERMOSTAT

LOW VOLTAGE

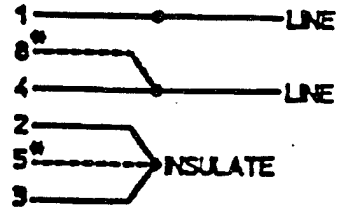

— THERMOSTAT
— THERMOSTAT

HIGH VOLTAGE

• R5125Q-50 BLOWERS PRODUCED AFTER SEPTEMBER 1992 (SER. NO. 0992)
DO NOT HAVE MOTOR LEADS 5 & 8.

MOTOR WIRING DIAGRAM FOR R6130Q-50 & R6P155Q-50

CONNECT THERMOSTAT
TO MOTOR PROTECTION
CIRCUIT



— THERMOSTAT

— THERMOSTAT

CONNECTION FOR THERMOSTAT MOTOR PROTECTION

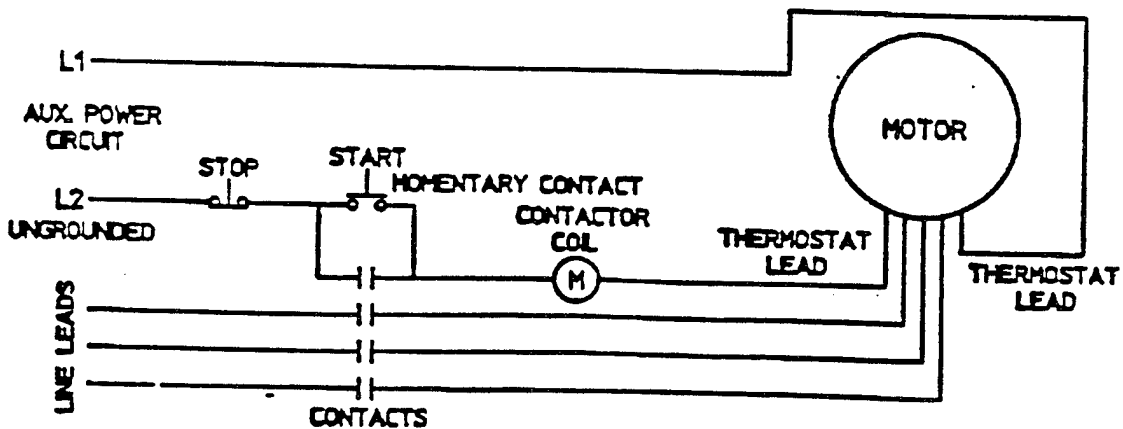

TERMOSTATS TO BE CONNECTED IN SERIES WITH
CONTROL AS SHOWN. MOTOR FURNISHED WITH
AUTOMATIC THERMOSTATS RATED A.C. 115-600V. 720VA

Blowers for
**SOIL VAPOR
EXTRACTION**

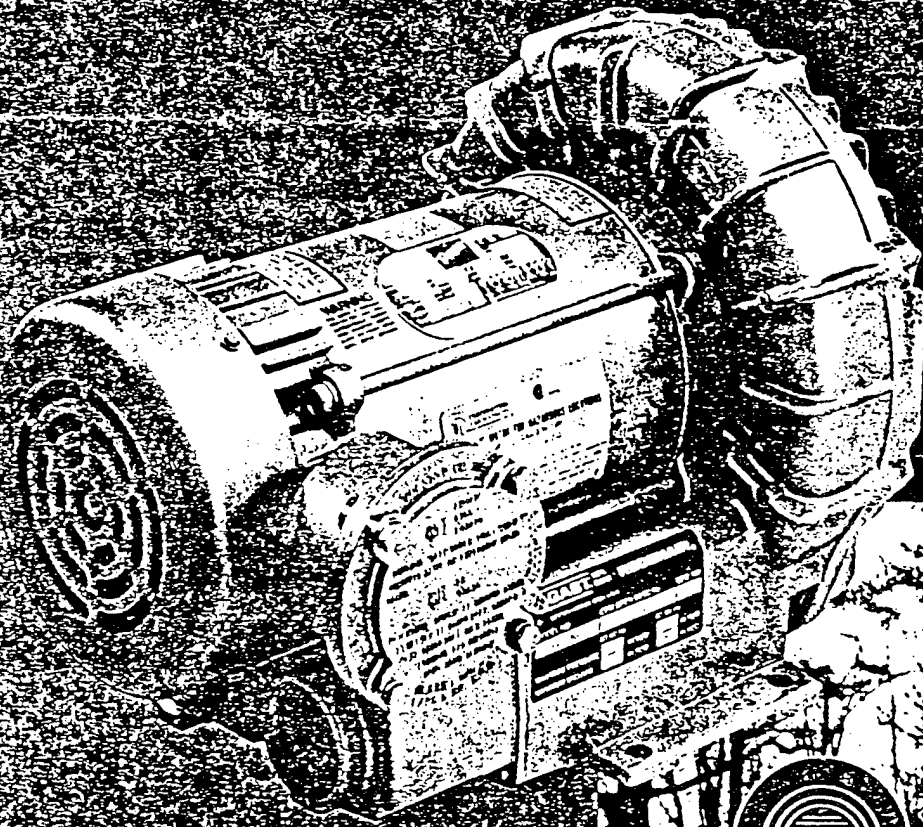

 **GAST**

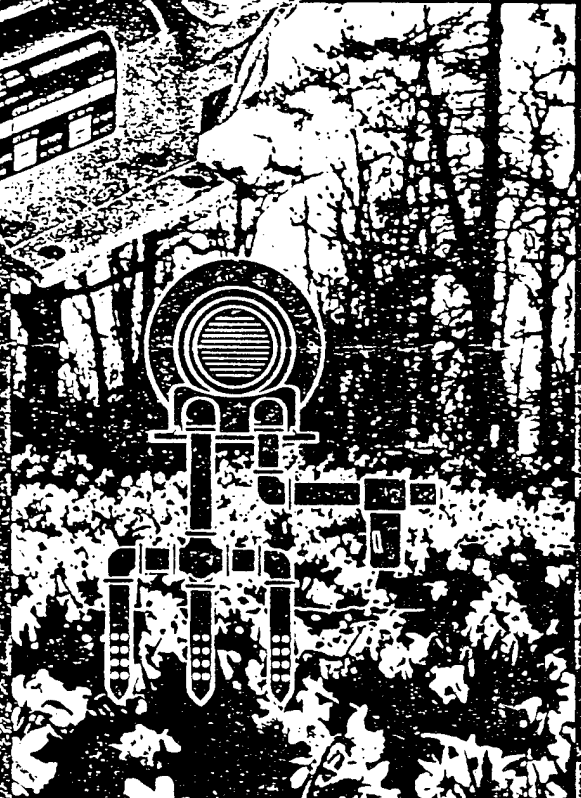

Your Warranty

REGARDLESS OF CAUSE, if a product you buy from this catalog does not work right, Gast will repair or replace it once, at no charge, for up to one year from the date of shipment from the factory.

In the course of repair or replacement, Gast may send you written recommendations on how to prevent a problem from happening again.

Gast reserves the right to withdraw this warranty if you do not follow these recommendations. Customer is responsible for freight charges both to and from Gast in all cases.

THIS WARRANTY DOES NOT APPLY TO ELECTRIC MOTORS, ELECTRICAL CONTROLS AND GASOLINE ENGINES, WHICH GAST OBTAINS FROM OTHER MANUFACTURERS. A MOTOR OR ENGINE CARRIES ONLY THE WARRANTY OF THE COMPANY THAT MAKES IT. THIS WARRANTY IS EXCLUSIVE AND IS IN LIEU OF ALL OTHER WARRANTIES, WHETHER WRITTEN, ORAL OR IMPLIED, INCLUDING THE WARRANTY OF MERCHANTABILITY AND OF FITNESS FOR ANY PARTICULAR PURPOSE. GAST'S LIABILITY IS IN ALL CASES LIMITED TO THE REPLACEMENT PRICE OF ITS PRODUCT. GAST SHALL NOT BE LIABLE FOR ANY OTHER DAMAGES, WHETHER CONSEQUENTIAL, INDIRECT, OR INCIDENTAL, ARISING FROM THE SALE OR USE OF ITS PRODUCTS.

Gast's sales personnel may modify this warranty, but only by signing a specific, written description of any modifications.

Gast Manufacturing Corporation

Customer Sales & Service

2550 Meadowbrook Road
Benton Harbor, MI 49022
Ph: 616/926-6171
Fax: 616/325-8268

Corporate Headquarters

Post Office Box 97
Benton Harbor, MI 49023
Ph: 616/926-6171
Fax: 616/927-0808

Eastern Sales Office

515 Washington Avenue
Carlstadt, NJ 07072
Ph: 201/933-8484
Fax: 201/933-5545

Midwestern Sales Offices

755 North Edgewood
Wood Dale, IL 60191
Ph: 708/860-7477
Ph: 800/800-8715
Fax: 708/860-1748

European Sales Office

Halifax Road, Cressex Estate
High Wycombe, Bucks HP 12 3SN
Ph: 44 494 523571
Fax: 44 494 436588
Telex 83488



FOR SOIL VAPOR

designed to supply up to
420 cfm (714m³/hr),
7 in Hg/224 mbar (90" H₂O) or
4 psi/249 mbar (100" H₂O)

The Gast reputation for quality and customer satisfaction is renowned throughout the world. Since 1921 we have been supplying air moving products that have set the industry standard of excellence. Our regenerative blowers for soil vapor extraction are no exception. Designed to extract vapors from contaminated soils, these models are used in conjunction with site-supplied special filters which clean the contaminants before venting them to the atmosphere. Since this process can take months or even years, Gast environmental blowers are a perfect solution; the only wearing part is the bearing, which is rated for up to 25,000 hours of service. Also, each of our motor-mounted models comes with a Class 1 Group D explosion-proof motor as a standard feature. Combining this quality with the strongest warranty in the business and a vast national and international distribution network providing product and technical support, we think you'll find our special Gast Regenair® blowers to be the right choice for your soil vapor extraction needs.

MODEL R4 SERIES

48" H₂O MAX. VAC., 51" H₂O MAX. PRESSURE
92 CFM OPEN FLOW

MODEL R5 SERIES

60" H₂O MAX. VAC., 65" H₂O MAX. PRESSURE
160 CFM OPEN FLOW

MODEL R6 SERIES

70" H₂O MAX. VAC., 75" H₂O MAX. PRESSURE
215 CFM OPEN FLOW

MODEL R6P SERIES

85" H₂O MAX. VAC., 100" H₂O MAX. PRESSURE
280 CFM OPEN FLOW

MODEL R7 SERIES

90" H₂O MAX. VAC., 90" H₂O MAX. PRESSURE
420 CFM OPEN FLOW

PRODUCT FEATURES

- Explosion-proof motors UL (class 1, group D)
- Sealed air stream
- Rugged construction
- Low maintenance

Product Dimensions

Model	Metric (mm)								U.S. Imperial (inches)							
	A	B	C	D	E	F	G	H	I	J	K	L	M	N	O	
R4110N-50	157	43	389	95	72	316	313	50	101	225	227	254	293	175	11	
	6.18	1.68	15.30	3.75	2.85	12.44	12.31	1.98	3.96	8.86	8.93	10.00	11.73	6.88	.44	
R4310P-50	157	43	356	95	72	316	313	50	101	225	227	254	293	175	11	
	6.18	1.68	14.03	3.75	2.84	12.44	12.31	1.98	3.96	8.86	8.93	10.00	11.73	6.88	.44	
R5125Q-50	178	46	445	114	91	361	344	60	121	260	262	298	350	173	15	
	7.00	1.82	17.50	4.50	3.58	14.22	13.56	2.38	4.75	10.25	10.31	11.75	13.78	6.81	.59	
R5325R-50	178	46	423	114	91	361	344	60	121	260	262	298	350	183	15	
	7.00	1.82	16.66	4.50	3.58	14.22	13.56	2.38	4.75	10.25	10.31	11.75	13.78	7.19	.59	
R6130Q-50	197	49	511	140	98	404	389	62	125	289	290	329	391	217	13	
	7.75	1.94	20.13	5.50	3.85	15.89	15.30	2.46	4.92	11.38	11.42	12.96	15.38	8.56	.52	
R6P1550Q-50	248	80	602	140	137	438	428	64	127	-	290	325	463	257	13	
	9.77	3.15	23.7	5.51	5.39	17.25	16.87	2.50	5.00	-	11.42	12.80	18.21	10.12	.50	
R6P355R-50	248	80	554	140	137	438	428	64	127	-	290	325	463	257	13	
	9.77	3.15	21.80	5.51	5.39	17.25	16.87	2.50	5.00	-	11.42	12.80	18.21	10.12	.50	
R7100R-50	274	92	577	216	212	545	457	100	200	-	375	410	509	257	14	
	10.79	3.64	22.72	8.50	8.33	21.46	18.00	3.94	7.88	-	14.76	16.14	20.02	10.12	.56	

Notice: Specifications subject to change without notice.

R4 Series R5 Series R6 Series

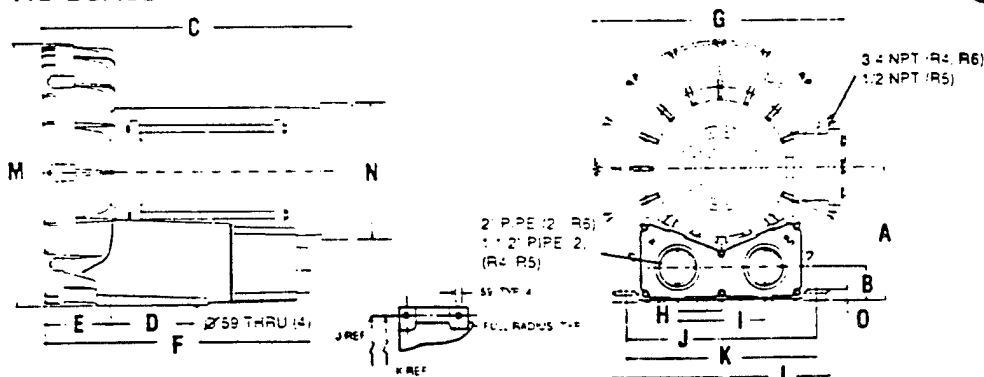

R6P Series R7 Series

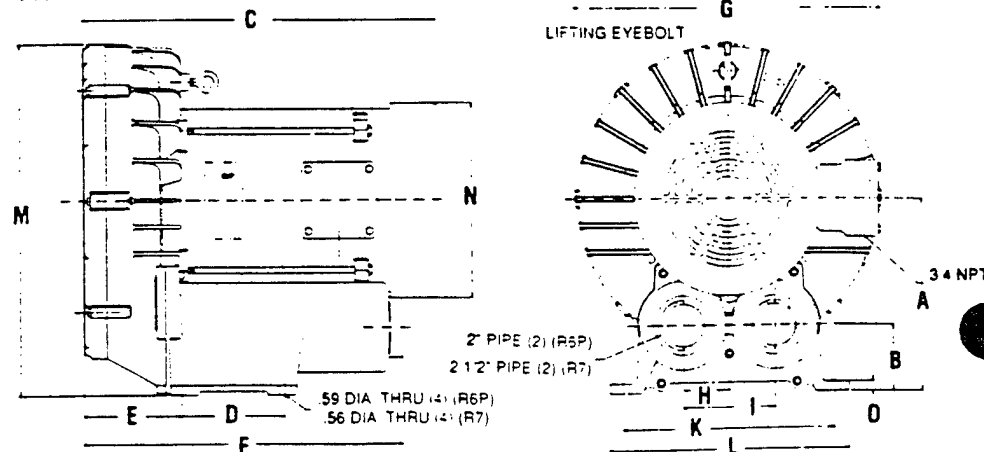

More models may be available - please consult factory

EXTRACTION...

Product Specifications

Model Number	Hz	Motor Specs	Full Load Amps	HP	RPM	Max Vac		Max Pressure		Max Flow		Net W lbs.
						"H ₂ O	mbar	"H ₂ O	mbar	cfm	m ³ /h	
R4110M-50	50	110/220-240-50-1*	9.2/5.2-4.6	0.6	2850	35	87	38	95	74	126	60
	60	115/208-230-60-1*	11.4/6.2-5.6	1.0	3450	48	120	51	127	92	156	
R4310P-50	50	220/380-50-3*	3.2/1.6	0.6	2850	35	87	38	95	74	126	58
	60	208-230/460-60-3*	3.4-3.3/1.65	1.0	3450	48	120	51	127	92	156	
R5125Q-50	60	115/230-60-1	25/12.5	2.0	3450	60	149	55	137	160	272	77
R5325R-50	50	190-220/380-415-50-3	5.0-4.4/2.5-2.6	1.5	2850	47	117	50	125	133	226	75
	60	208-230/460-60-3	6.0-5.6/2.8	2.0	3450	60	149	65	162	160	272	
R6130Q-50	50	220-240-50-1	14.7-13.5	2.5	2850	65	162	75	187	182	309	129
	60	230-60-1	16.3	3.0	3450	70	174	60	149	215	365	
R6P155Q-50	50	220-240-50-1	20.8-19.1	4.0	2850	65	162	80	199	235	399	243
	60	230-60-1	29.9	5.5	3450	85	212	95	237	280	476	
R6P355R-50	50	190-220/380-415-50-3	14.9-11/7.45-5.8	4.5	2850	65	162	80	199	232	394	233
	60	208-230/460-60-3	20-18/9	6.0	3450	85	212	100	249	280	476	
R7100R-50	50	190-220/380-415-50-3	20.8-18.9/10.4-9.5	8	2850	72	179	80	199	350	595	297
	60	208-230/460-60-3	26.5-24/12	10	3450	90	224	90	224	420	714	

*Models have automatic reset thermal protection.

Product Performance (Metric/U.S. Imperial)

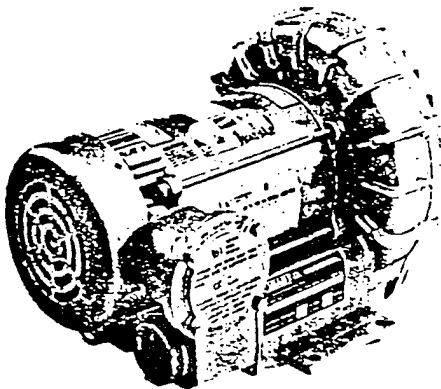

NOTE: These units with explosion-proof motors are designed specifically for qualified OEMs in the soil vapor extraction industry. They are not intended to be applied for other uses without written acknowledgment from an authorized employee of Gast Manufacturing Corporation.

Model R4 Series

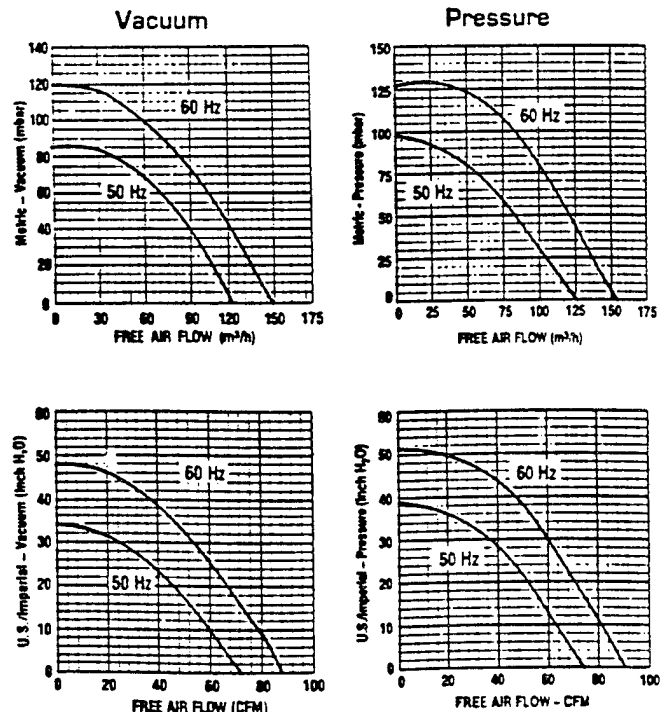

Model R5 Series

Vacuum

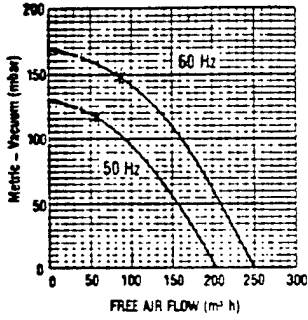

Pressure

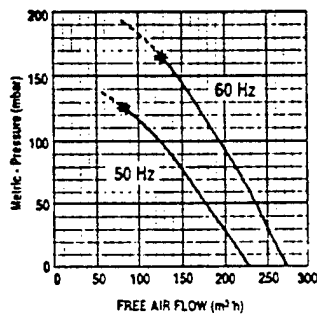

Model R6 Series

Vacuum

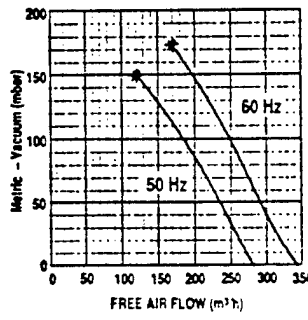

Pressure

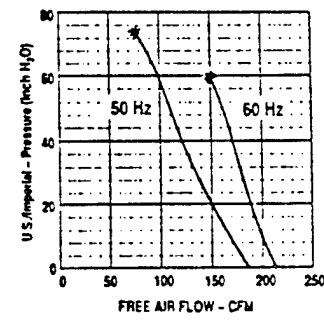
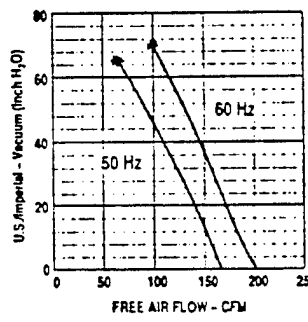
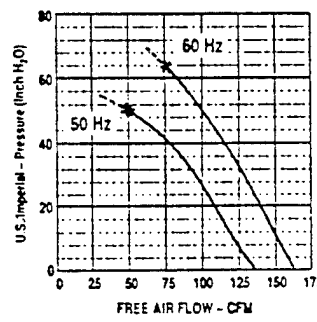
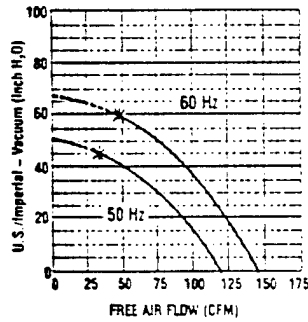
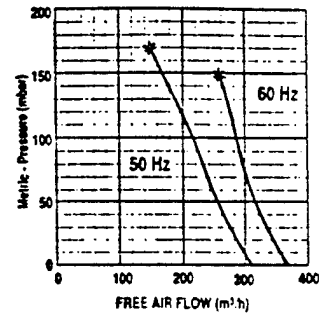

Model R6P Series

Vacuum

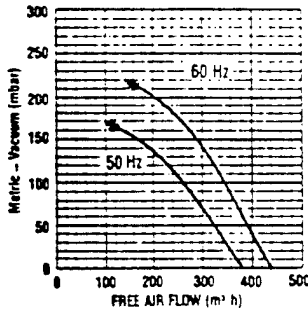

Pressure

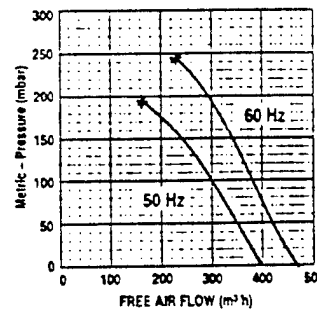

Model R7 Series

Vacuum

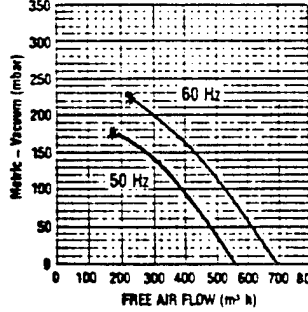

Pressure

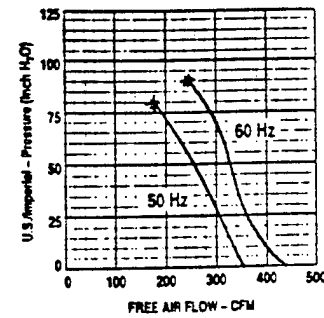
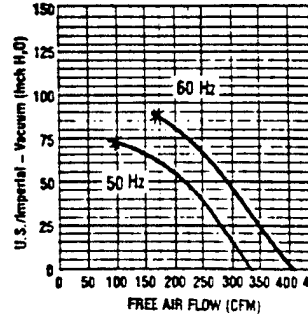
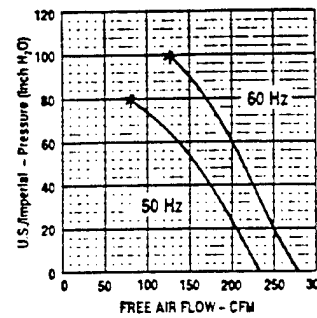
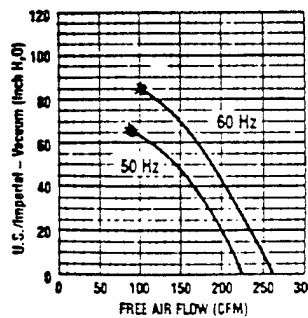
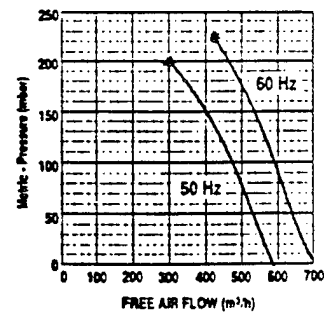

Blower Accessories

In-line Filters

The impeller of a blower passes very close to the housing. It is always wise to have an inlet or in-line filter to ensure troublefree life.

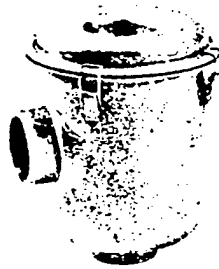

Model No.	R4	R5	R6,R6P	R7
Part No.	AJ151D	AJ151E	AJ151G	AJ151H
Replacement Element	AJ135E	AJ135F	AJ135G	AJ135C
Micron	10	10	10	10

Vacuum and Pressure Gauges

To monitor the system performance so as not to exceed maximum duties. Using two (one on each side of the filter) is a great way to know when the filter needs servicing.



- Vacuum Gauge, Part #AJ497, 2 5/8" Dia., 1/4" NPT, 0-60 in. H₂O and 0-150 mbar
- Vacuum Gauge, Part #AE134, 2 5/8" Dia., 1/4" NPT, 0-160 in. H₂O and 0-400 mbar
- Pressure Gauge, Part #AJ496, 2 5/8" Dia., 1/4" NPT, 0-60 in. H₂O and 0-150 mbar
- Pressure Gauge, Part #AE133, 2 5/8" Dia., 1/4" NPT, 0-160 in. H₂O and 0-400 mbar
- Pressure Gauge, Part #AE133A, 2 5/8" Dia., 1/4" NPT, 0-200 in. H₂O

Horizontal Swing Type Check Valve

Designed to prevent back-wash of fluids that would enter the blower. Also prevents air back-streaming if needed. They can be mounted with their discharge either vertical or horizontal. Valve will open with 3" of water pressure.

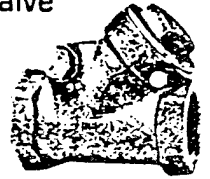

Model No.	R4,R5	R6,R6P	R7
Part No.	AH326D	AH326F	AH326G
	1 1/2" NPT	2" NPT	2 1/2" NPT

Moisture Separator

The purpose of the moisture separator is to remove liquids from the gas stream in a soil vapor extraction process. This helps protect the blower from corrosion and a build up of mineral deposits.



MODEL	LIQUID CAPACITY		USED ON
	GALLONS		
RMS160	10		R4, R4P, R5
RMS200	19		R4, R4P, R5, R6
RMS300	19		R5, R6, R6P
RMS400	40		R6P, R7

Relief Valve

By setting a relief valve at a given pressure/vacuum you can be assured that no harm will come to the blower or products in your application from excessive duties.

- Pressure/Vacuum Relief Valve, 1 1/2" NPT, Adjustable 30 - 170 in. H₂O, 200 cfm max. Part #AG258

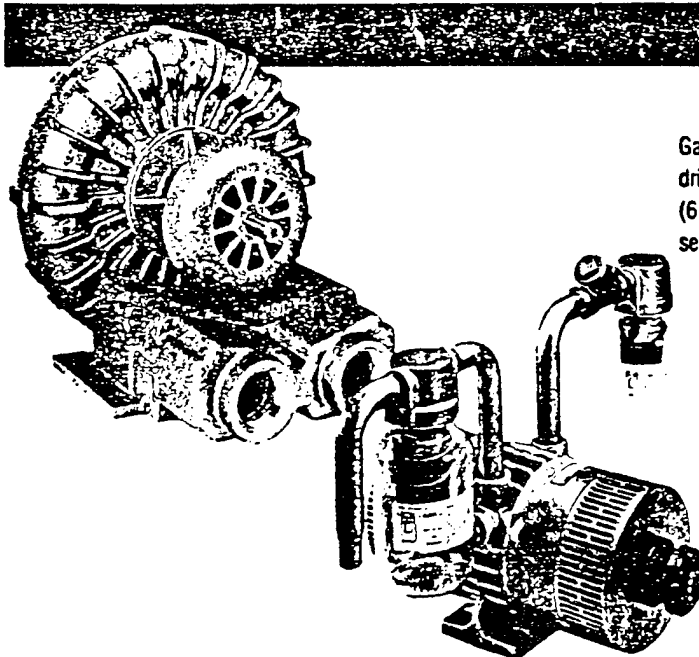
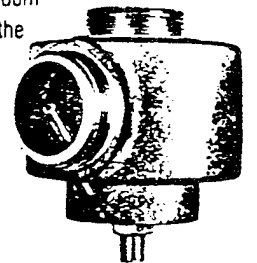

Gast also offers other models that are ideal for soil sparging. Our separate drive blowers are available in 4 sizes to 15 hp, pressures to 170" H₂O (6 psi). Rotary vane compressors are available in motor mounted or separate drive styles up to 5 hp, pressures to 20 psi.

Oilless Regenerative Blowers, Motor Mounted to 92 cfm



REGENAIR® R4 Series

PRESSURE

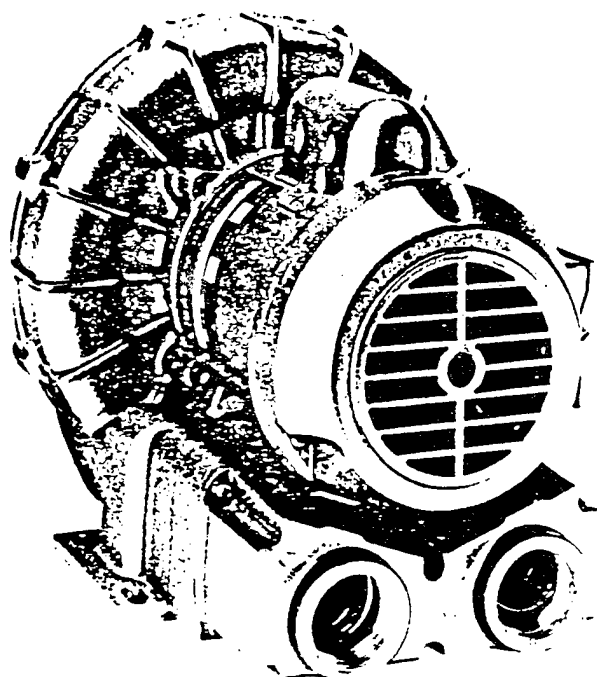

MODEL R4110-2
52" H₂O MAX. PRESSURE, 92 CFM OPEN FLOW

PRODUCT FEATURES

- Oilless operation
- TEFC motor mounted
- Can be mounted in any plane
- Rugged construction/low maintenance
- Can be operated blanked-off

COMMON MOTOR OPTIONS

- 115/208-230V, 60 Hz; 110/220-240V, 50 Hz, single phase
- 208-230/460V, 60 Hz; 190-230/380-415V, 50 Hz, three phase
- 575V, 60 Hz, three phase

RECOMMENDED ACCESSORIES

- Pressure gauge AJ496
- Filter AG338
- Muffler AJ121D
- Relief valve AG258

Various brand name motors are used on any model at the discretion of Gast Mfg. Corp.

Important Notice:

Pictorial and dimensional data is subject to change without notice.

Product Dimensions Metric (mm) U.S. Imperial (inches)

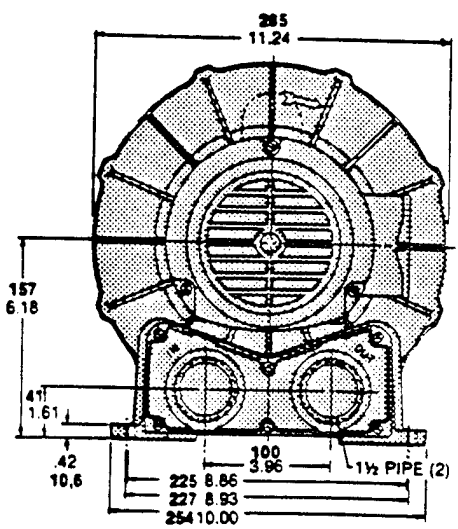
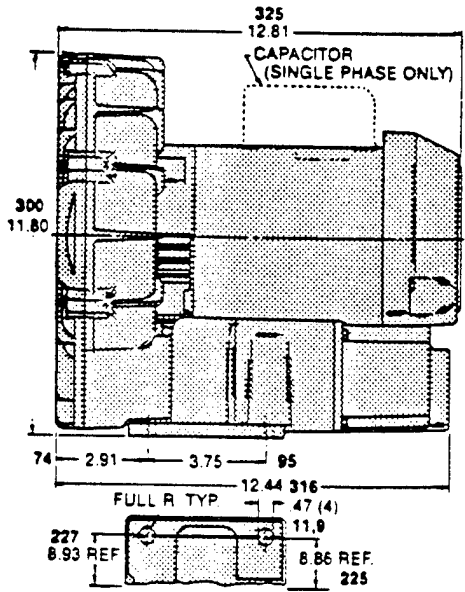

Product Specifications

Model Number	Motor Specs	Full Load Amps	HP	RPM	Max Pressure		Max Flow		Net Wt.	
					H ₂ O	mbar	cfm	m ³ h	lbs.	kg
R4110-2	110/220-240-50-1	9.0/4.5-5.7	0.6	2850	38	95	74	126	41	18.6
	115/208-230-60-1	9.8/5.2-4.9	1.0	3450	52	130	92	156		
R4310A-2	190-220/380-415-50-3	2.6-3.3/1.3-1.4	0.6	2850	38	95	74	126	41	18.6
	208-230/460-60-3	3.4-3.2/1.6	1.0	3450	52	130	92	156		

Product Performance (Metric U.S. Imperial) **Black line on curve is for 60 cycle performance.**
Blue line on curve is for 50 cycle performance.

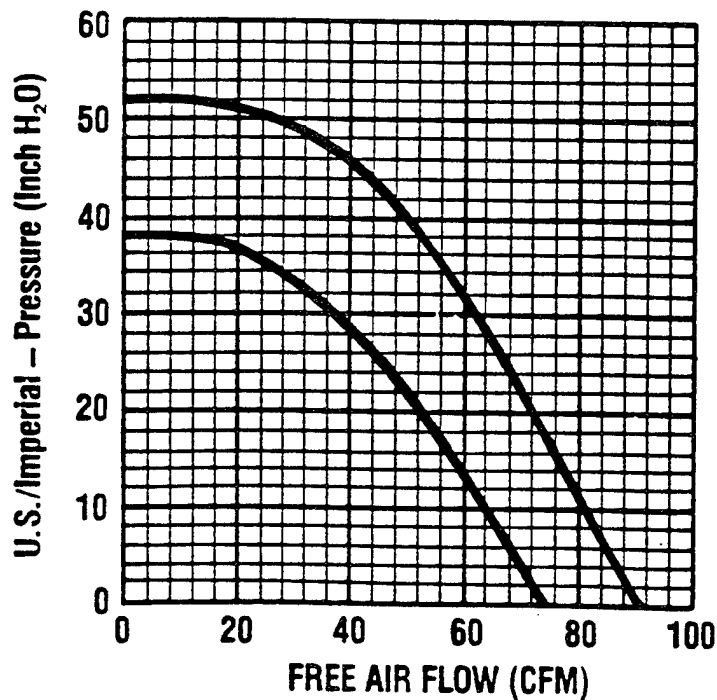
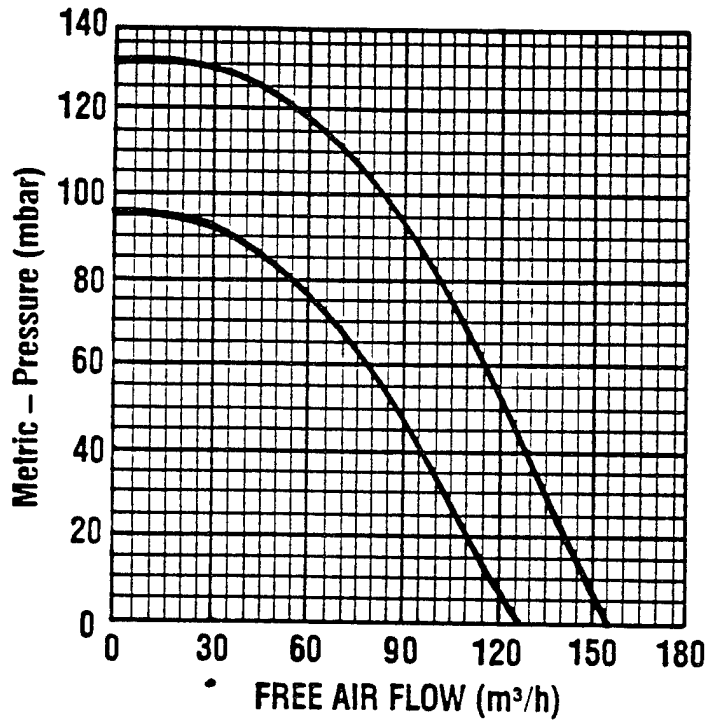

Oilless Regenerative Blowers, Motor Mounted to 160 cfm



REGENAIR® R5 Series

PRESSURE

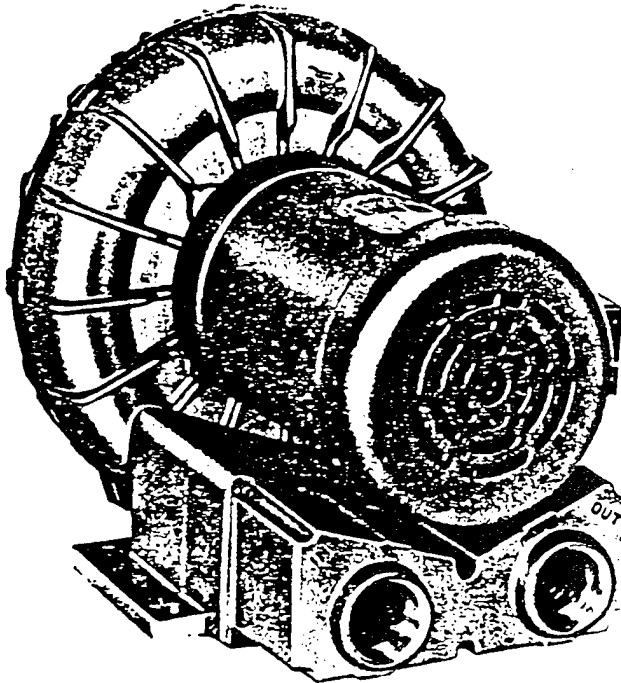

MODEL R5325A-2
65" H₂O MAX. PRESSURE, 160 CFM OPEN FLOW

PRODUCT FEATURES

- Oilless operation
- TEFC motor mounted
- Can be mounted in any plane
- Rugged construction/low maintenance

COMMON MOTOR OPTIONS

- 115/208-230V, 60 Hz, single phase
- 208-230/460V, 60 Hz, 190-220/380-415V, 50 Hz, three phase
- 575V, 60 Hz, three phase

RECOMMENDED ACCESSORIES

- Pressure gauge AE133
- Filter AG338
- Muffler AJ121D
- Relief valve AG258

Various brand name motors are used on any model at the discretion of Gast Mfg. Corp.

Important Notice:

Pictorial and dimensional data is subject to change without notice.

Product Dimensions Metric (mm) U.S. Imperial (inches)

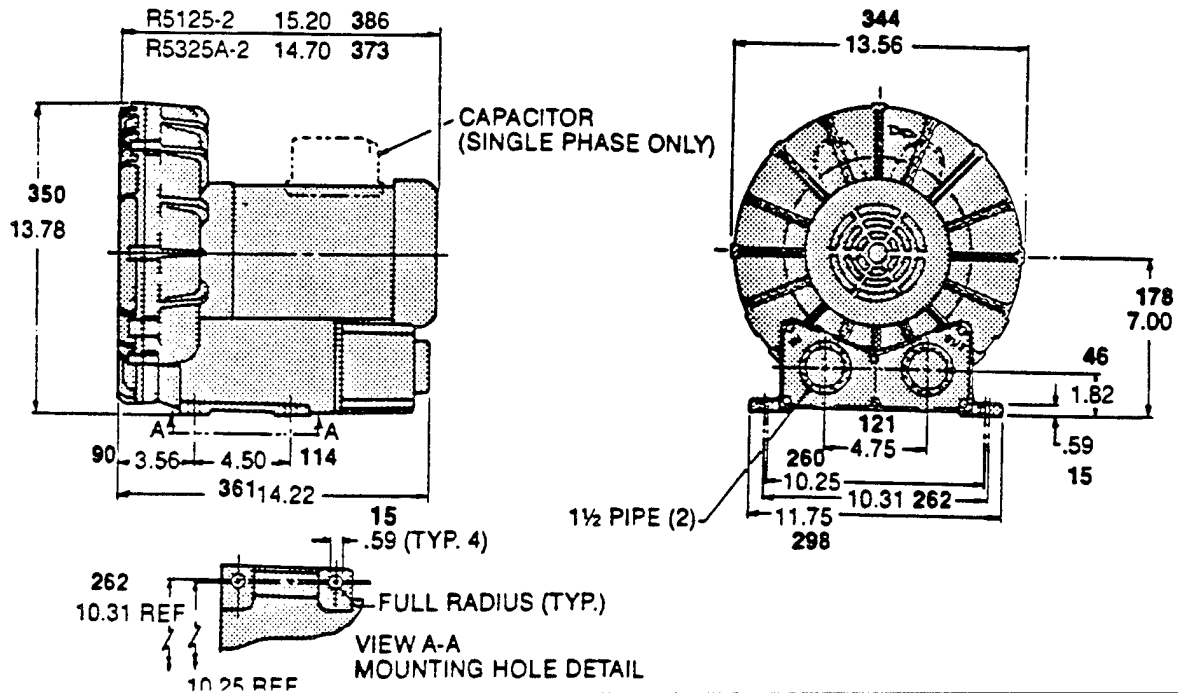

Product Specifications

Model Number	Motor Specs	Full Load Amps	HP	RPM	Max Pressure		Max Flow		Net Wt.	
					"H ₂ O	mbar	cfm	m ³ /h	lbs.	kg
R5325A-2	190-220/380-415-50-3	6.6-6.7/3.3-3.5	1.35	2850	50	125	133	226	65	29,5
	208-230/460-3	6.9/3.45	2.5	3450	65	162	160	272		
R5125-2	115/208-230-60-1	22.4/12.4-11.2	2.5	3450	60	149	160	272	73	33,1

Product Performance (Metric U.S. Imperial) Black line on curve is for 60 cycle performance.
 Blue line on curve is for 50 cycle performance.

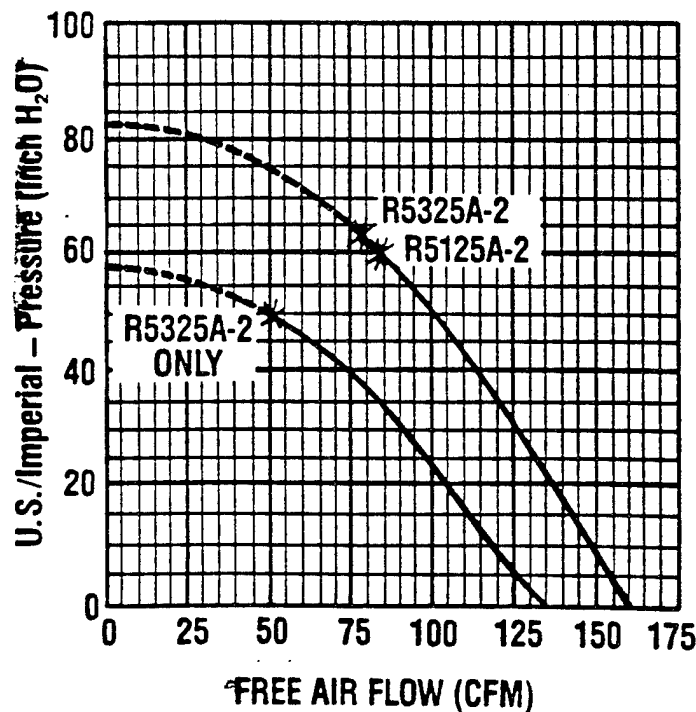
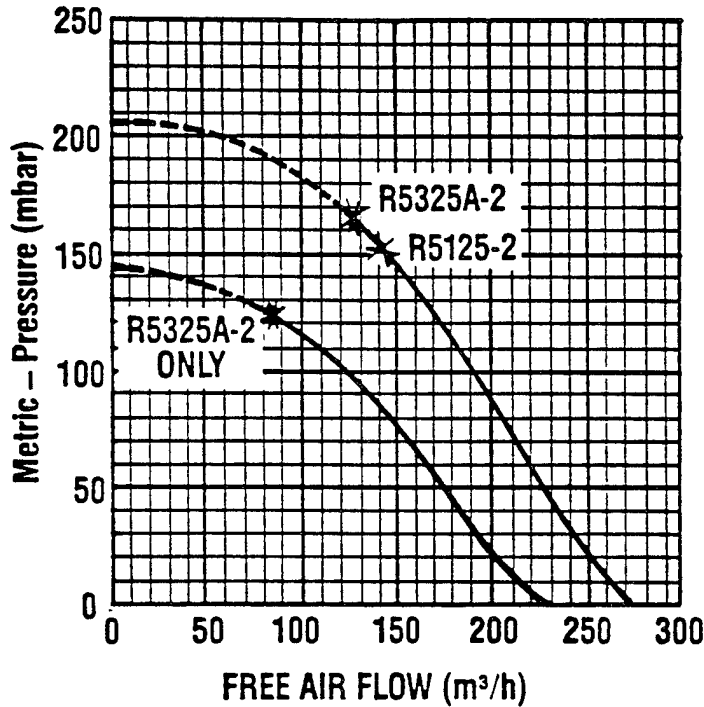

*Recommended maximum duty.
 - - - - Intermittent duty only.

Product Specifications

Model Number	Hz	Motor Specs	HP	RPM	Max Vac		Max Flow		Net Wt.	
					"H ₂ O	mbar	cfm	m ³ h	lbs.	kg
R4110N-50	50	110/220-240-50-1	0.6	2850	35	924	72	122	60	28
	60	115/208-230-60-1	1.0	3450	48	895	88	150		
R4310P-50	50	220/380-50-3*	0.6	2850	35	924	72	122	58	27
	60	208-230/460-60-3*	1.0	3450	48	895	88	150		
R5125Q-50	60	115/230-60-1*	2.5	3450	60	865	145	246	77	35
R5325R-50	50	190-220/380-415-50-3*	1.85	2850	47	897	120	204	75	34
	60	208-230/460-60-3*	2.50	3450	60	865	145	246		
R6P355R-50	50	190-220/380-415-50-3*	4.5	2850	70	840	235	400	247	112
	60	208-230/460-60-3*	6.0	3450	90	790	260	442		

*Motors do not have thermal protection with automatic reset.

Product Performance (Metric U.S. Imperial)

Model R4 Series

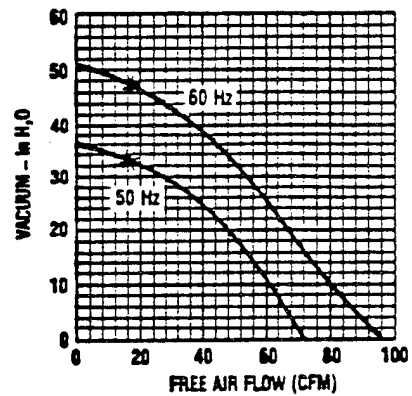
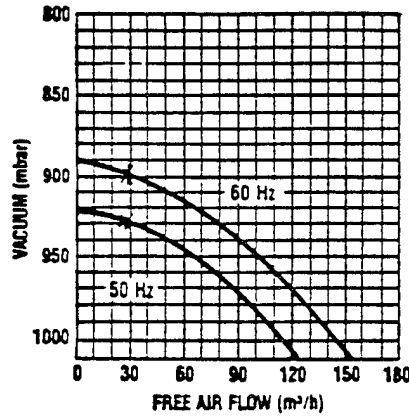

Model R5 Series

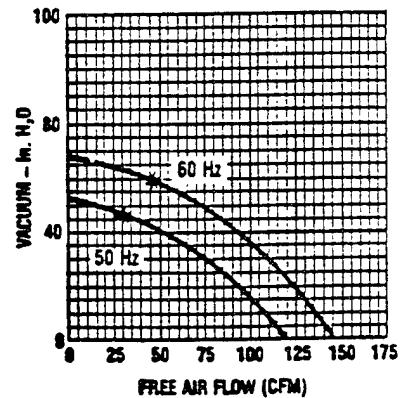
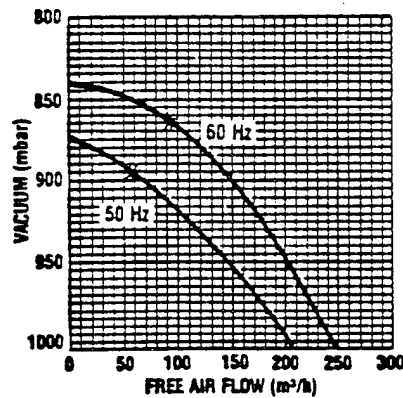

Model R6P Series

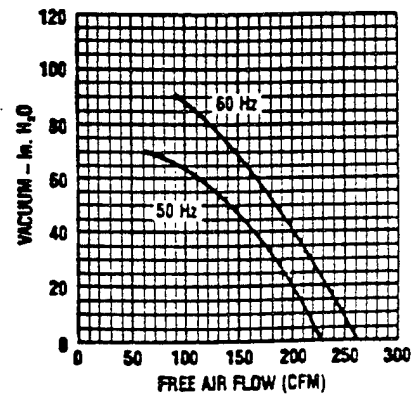
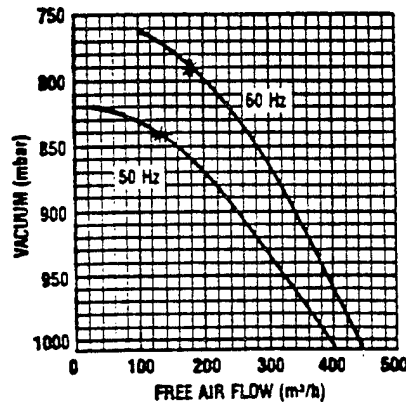

*Minimum flow permissible through the unit for trouble-free, continuous operation.

REGENAIR ACCESSORIES

Inline Filters (for vacuum)

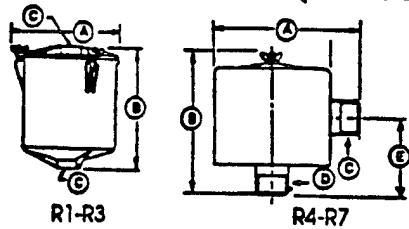

Model Number	R1 & R2	R3	R4, R5 & SDR4	R6P SDR5, SDR6 R6PP, R6PS	R7
Part #	AV460	AV460C	AG337	AJ151G	AJ151H
Dim A	8.25"	8.25"	11.75"	8.00"	16.25"
Dim B	8.875"	8.875"	4.75"	10.25"	27.13"
Dim C	1" FPT	1 1/4" FPT	1 1/2" MPT	2 1/2" MPT	3" MPT
Dim D	-	-	1 1/2" FPT	2 1/2" MPT	3" MPT
Dim E	-	-	2.38	5.50	18.50
Replacement Element	AV469	AV469	AG340	AJ135G	AJ135C
Micron	10	10	25	10	10

MPT = Male Pipe Thread
FPT = Female Pipe Thread

Mufflers

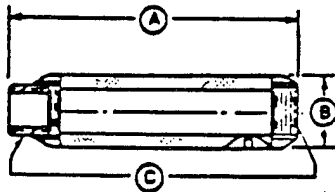

Model Number	R2	R3	R4, R5 SDR 4" & SDR5"	R6, SDR6" R6P R6PP, R6PS	R7
Part #	AJ121B	AJ121C	AJ121D	AJ121F	AJ121G
Dim. A	7.46"	7.94"	12.75"	17.05"	17.44"
Dim. B	2.38"	2.62"	3.25"	3.63"	4.25"
Dim. C	1" NPT	1 1/4" NPT	1 1/2" NPT	2" NPT	2 1/2" NPT

* For Inlet Only
** Approximately

Fittings

Pipe Size	1"	1 1/4"	1 1/2"	2"	2 1/2"
Tee	BA415	BA431	BA432	BA433	BA434
Common Elbow	BA220	BA244	BA230	BA247	BA248
Nipple	BA752	BA809	BA783	BA810	BA813
Plastic Male Pipe Hose Barb	AJ117A	AJ117B	-	-	-
Hose I.D.	1.25	1.25	-	-	-
Metal Male Pipe Hose Barb	AJ117D	AJ117E	AJ117C	AJ117G	AJ117H
Hose I.D.	1.00	1.25	1.50	2.50	3.00

Horizontal Swing Type Check Valve

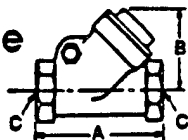

Model Number	R1, R2	R3	R4, R5 SDR 4" & SDR5	R6, SDR6" R6P R6PP, R6PS	R7
Part #	AH3268	AH326C	AH326D	AH326E	AH326G
Dim. A	3.57	4.19	4.50	5.25	8
Dim. B	2.32	2.69	2.94	3.82	5.07
Dim. C	1" NPT	1 1/4" NPT	1 1/2" NPT	2" NPT	2 1/2" NPT

Inlet Filters (for pressure units only)

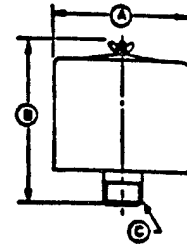

Model Number	R1 & R2	R3	R4, R5 & SDR4	R6, SDR5 SDR6, R6P R6PP, R6PS	R7
Part #	AJ126B	AJ126C	AG338	AJ126F	AJ126G
Dim A	6.00"	6.00"	10.63"	10.63"	10.00"
Dim B	4.62"	7.12"	4.81"	4.81"	13.12"
Dim C	1" MPT	1 1/4" MPT	1 1/2" FPT	2" FPT	2 1/2" MPT
Replacement Element	AJ134B	AJ134C	AG340	AG340	AJ135A
Micron	10	10	25	25	10

All are heavy duty for high amounts of particulates. Inlet filters for REGENAIR blowers are drip-proof when mounted as shown.

Pressure-Vacuum Gauge



Pressure Gauge, Part #AJ496, 2 5/8" Diameter, 1/4" NPT, 0-60 inches H₂O and 0-150 mbar

Pressure Gauge, Part #AE133A, 2 5/8" Diameter, 1/4" NPT, 0-200 inches H₂O and 0-500 mbar

Vacuum Gauge, Part #AJ497, 2 5/8" Diameter, 1/4" NPT, 0-60 inches H₂O and 0-150 mbar

Vacuum Gauge, Part #AE134, 2 5/8", Diameter, 1/4" NPT, 0-160 inches H₂O and 0-400 mbar

Relief Valve

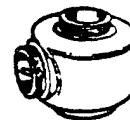

Pressure/Vacuum Relief Valve, Part #AG258, 1 1/2" NPT, Adjustable 30-170 inches H₂O, 200 CFM maximum

Silencer for Relief Valve, Part #AJ121D

APPENDIX B
ROTARY-VANE BLOWER INFORMATION

70-230
G360PL
7-89



MANUFACTURING CORPORATION
P. O. BOX 97, BENTON HARBOR, MICHIGAN 49022
PHONE 616-924-6171

**PARTS LIST and OPERATING
INSTRUCTIONS
1067, 2067, and 2567**

**OIL LESS
VACUUM PUMPS
and
COMPRESSORS**

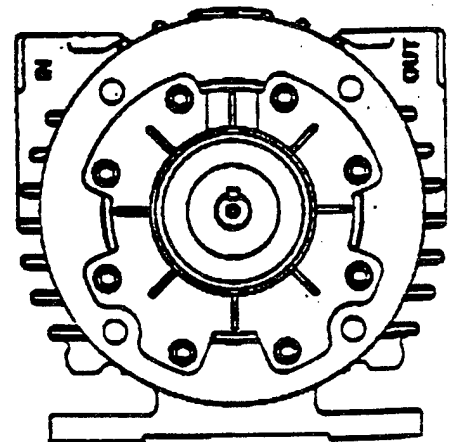
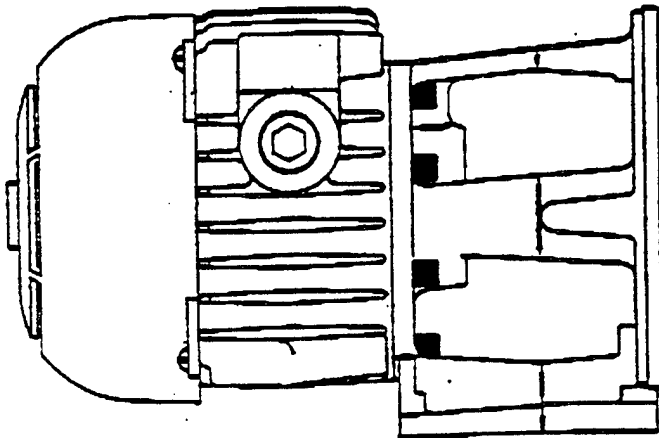

**WARNING: UNIT SHOULD NOT PUMP EXPLOSIVE GASES OR
BE USED IN EXPLOSIVE AMBIENTS.**

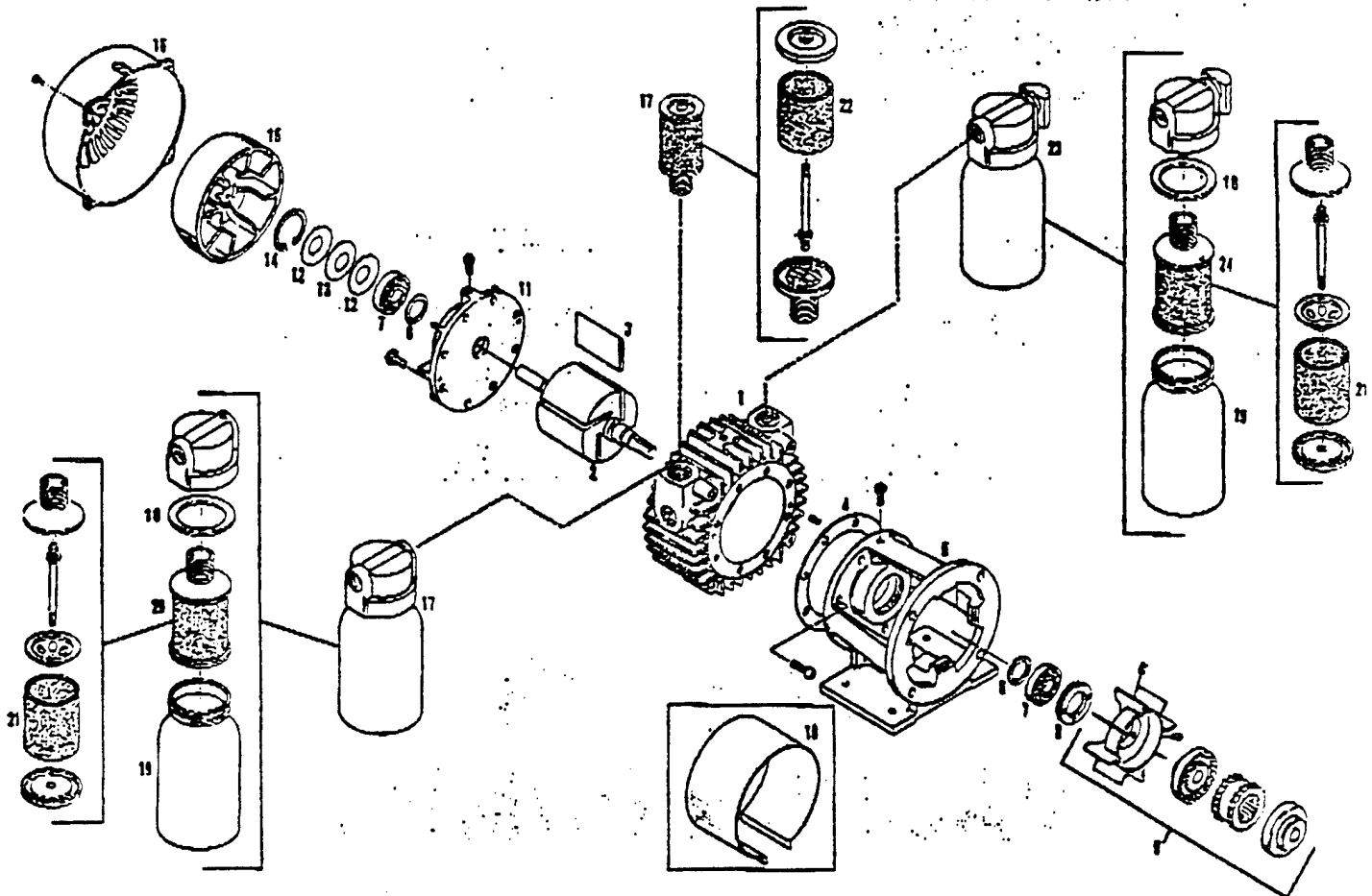

REF. NO.	DESCRIPTION	PART. QNTY.	1067-V102	1067-P102	2067-V102	2067-P102	2067-V102	2067-P102
1	Body	1	AH048	AH048	AH191	AH191	AH070	AH033
2	Rotor Assembly	1	AH076	AH076	AH192	AH192	AH192	AH192
3	Vane	4	AH030	AH030	AH196	AH196	AH196	AH196
4	Beary Gasket	1	AH067	AH067	AH067	AH067	AH067	AH067
5	Front Bearing	1	AH008	AH008	AH008	AH008	AH008	AH008
6	Deflaser	2	AH193	AH193	AH193	AH193	AH193	AH193
7	Ball Bearing (Drive & Dead)	2	AC094	AC094	AC094	AC094	AC094	AC094
8	End Cap, Drive	1	AB038A	AB038A	AB038A	AB038A	AB038A	AB038A
9	Fan Casing Assembly	1	AH198	AH198	AH198	AH198	AH198	AH198
10	Fan Guard	1	AH194	AH194	AH194	AH194	AH194	AH194
11	End Plate Dead	1	AH006	AH006	AH006	AH006	AH006	AH006
12	Belleville Springs	2	AB037	AB037	AB037	AB037	AB037	AB037
13	Washer	2	AB038	AB038	AB038	AB038	AB038	AB038
14	Snap Ring	1	AB039	AB039	AB039	AB039	AB039	AB039
15	Fan	1	AC096	AC096	AC096	AC096	AC096	AC096
16	Fan Guard	1	AC102B	AC102B	AC102B	AC102B	AC102B	AC102B
17	Intake Filter Assembly	1	AA000C	AA000F	AA000D	AA000D	AA000D	AA000G
18	Gasket	2	AA005		AA005		AA005	
19	Jar	2	AA001		AA001		AA001	
20	Filter Assembly	1	AC035-1		AC035-1		AC035-1	
21	Cartridge	2	AC093	AC093	AC093		AC093	
22	Filter Roll	1		DB448		DB448		DB448
23	Muffler	1	AA000F		AA000F		AA000F	
24	Muffler Assembly	1	AC036-1		AC036-1		AC036-1	
	Service Kit		K086	K086	K086	K087	K086	K087

* Denotes parts in service kit.
When corresponding or ordering spare parts, please give complete model and serial numbers.

OPERATING AND MAINTENANCE INSTRUCTIONS

CONSTRUCTION: The end plate, body, rotor and foot bracket are all cast iron. Consequently any moisture that accumulates in the pump will tend to corrode the interior especially if it stands idle. The vanes are made of hard carbon and are precision ground. They should last 5,000 to 10,000 hours depending upon the degree of vacuum pressure at which the pump is run.

STARTING: CAUTION: NEVER LUBRICATE THIS OILLESS AIR PUMP. The carbon vanes and grease packed motor bearings require no oil. If the motor fails to start or slows down when under load shut the unit off and unplug. Check that the supply voltage agrees with the motor post terminals and the motor data name plate. **CAUTION: ALL DUAL VOLTAGE MOTORS ARE SHIPPED FROM THE FACTORY WIRED FOR THE HIGH VOLTAGE.** If the pump is extremely cold allow it to warm to room temperature before starting. If anything appears to be wrong with the motor return the complete pump to an authorized Gast service facility.

To minimize noise and vibration the unit should be mounted on a solid surface that will not resonate. Use of shock mounts or vibration isolation material is recommended. Inlet or discharge noise can be minimized by attaching the muffler. The unit should not be allowed to operate in ambient air temperatures in excess of 40°C (104°F). If the motor fails to start or slows down when under load shut the unit off and unplug. Check that the supply voltage agrees with the motor post terminal setup and the motor data name plate.

FILTRATION: Care must be taken to insure that any particles (dirt, chips, foreign material) often found in new plumbing not be allowed to enter the unit. Liquid, moisture vapor, or oil based contaminants will affect pump performance and must be filtered from entering the pump.

Dirty filters restrict air flow and if not corrected could lead to possible motor overload, poor performance and early pump failure. Check filters periodically and clean when necessary by removing felts and washing in Gast flushing solvent (part number AH255). Dry with compressed air and replace.

FLUSHING: Should excessive dirt, foreign particles, moisture, or oil be permitted to enter the pump the vanes

will act sluggish or even break. Flushing the pump should remove these materials. First remove the filter & muffler clean with solvent & dry with compressed air.

DISASSEMBLY: Begin by removing the fan guard and fan. The dead end plate may be removed using a wheel puller. The vanes and body area can then be inspected for damage or further cleaning. Unless scoring is visible do not remove drive end plate and top clearance will be maintained. If further repair is required remove the spanner nut before using a wheel puller to remove the drive end plate. Both bearings are a press fit on the shaft.

REASSEMBLY: First attach the drive end plate (but do not tighten bolts) and press the bearing on the shaft (be sure to properly support the inner race). If required top clearance (between rotor & body) should then be set (for 1067 models it is .0015 and for 2067 and 2567 it is .003). Now replace the dead end plate and bearing. Then the bellville springs, washer and snap ring should be replaced. With a dial indicator on the dead end shaft to show any movement, install spanner nut (with adhesive to keep from vibrating loose) until indicator moves .002-.0025. Check shaft for ease of rotation.

HAZARD PREVENTION:

WARNING: MAKE SURE THE ELECTRIC MOTOR IS PROPERLY GROUNDED AND THE WIRING IS DONE BY A QUALIFIED ELECTRICIAN FAMILIAR WITH NEMA MG2 SAFETY STANDARDS, NATIONAL ELECTRIC CODE AND ALL LOCAL SAFETY CODES.

WARNING: THE ELECTRIC MOTOR MAY BE THERMALLY PROTECTED AND WILL AUTOMATICALLY RESTART WHEN THE PROTECTOR RESETS.

WARNING: WHEN SERVICING ALL POWER TO THE MOTOR MUST BE DE-ENERGIZED AND DISCONNECTED. ALL ROTATING COMPONENTS MUST BE AT A STAND STILL.

WARNING: DO NOT USE KEROSENE OR OTHER COMBUSTIBLE SOLVENTS OR OPERATE PUMP IN EXPLOSIVE AMBIENTS.

Performance Data

Model	Vacuum			Maximum Vacuum
	0" HG	10" HG	20" HG	
1067	8.5 CFM	6.0 CFM	2.0	26" HG
2067	16.0	9.0	3.0	27"
2567	20.0	13.0	5.0	27"

Model	Pressure			
	0 PSI	5 PSI	10 PSI	15 PSI
1067	8.5 CFM	7.5 CFM	7.0 CFM	6.5 CFM
2067	17.0	14.0	12.0	11.0
2567	21.0	18.0	17.0	16.0

Gast Manufacturing Co., Ltd.
Coronation Road, Cressex Estate
High Wycombe, Bucks HP12 3SN
England 23571
FAX 444-943-6588

Gast Manufacturing Corp.
2550 Meadowbrook Road
Benton Harbor MI 49022
616/926-6171
FAX 616-925-8288

Gast Manufacturing Corp.
505 Washington Ave.
Caristadt NJ 07072
201/933-8484
FAX 201-933-5545

Brenner-Fiedler & Assoc.
13824 Bentley Place
Cerritos, Ca. 90701
213-404-2721
FAX 213-404-7975

Wainbee, Ltd.
121 City View Drive
Rexdale, Ontario, Canada M9W 5A9
416/243-1900
FAX 416-243-2336

Wainbee, LTD.
215 Brunswick Blvd.
Pointe Claire, Montreal
Canada H9R 4R7
514/697-8810
FAX 514-697-3070

Note: All general correspondence should be directed to Gast Mfg Corp, P.O. Box 97, Benton Harbor, MI 49022

ACCESSORIES

CHECK VALVES—vacuum	
A2236	1/2" NPT, male
A2238	1/2" NPT, female
A2239A	3/4" NPT, female
CHECK VALVES—vacuum swing	
A2238A	3/4" NPT
A2238B	1" NPT
CORDS—ELECTRIC	
A2216	1/2" 1/2" 3/4" hp, 115V without switch, 10 ft.
A2218	1/2" 3/4" hp, 220V without switch, 10 ft.
A2220	1/2" 1/2" 3/4" hp, 115 V with switch, 10 ft.
FILTERS—no jar	
AC433	3/4" female NPS, 10 in length
AC433	1/2" male NPS, 10 in length
AC438	3/4" male NPS, 10 micron
A2209E	3/4" female NPS, 80 micron
A2209F	1/2" male NPS, 80 micron
A2209G	3/4" male NPS, 80 micron
E200A	1/2" male NPS, 80 micron
E200B	1/2" male NPS, 80 micron
AD750	1" male NPS, 80 micron
FILTERS—glass jar	
AA2170	1/2" NPS, 2 oz., 80 micron
AA2224	1/2" NPS, 3/4" oz., 80 micron
AD240	1" NPS, 2 oz., 80 micron
AB280	3/4" NPS, 1 qt., 10 micron
AB2990	1/2" NPS, 1 qt., 80 micron
AB2900	1/2" NPS, 1 qt., 80 micron
AB290F	1/2" NPS, 1 qt., 10 micron
AB2910	3/4" NPS, 1 qt., 10 micron
AB2910C	3/4" NPS, 1 qt., 80 micron
AA200C	1/2" NPS, 1 qt., 10-micron
AA200E	1/2" NPS, 1 qt., 80 micron
AA200J	3/4" NPS, 1 qt., 10 micron
AA200J	3/4" NPS, 1 qt., 80 micron
V4000	1/2" NPS, 8 oz., 80 micron
V6000	3/4" NPS, 8 oz., 80 micron
V400C	1/2" NPS, 8 oz., 80 micron
FILTERS—metal jar	
AB2080	1/2" NPS, 1/2" qt., 10 micron
AB212	1/2" NPS, 1/2" qt., 10 micron
AB208B	3/4" NPS, 1/2" qt., 10 micron
AB209	1/2" NPS, 1/2" qt., 80 micron
AB208	3/4" NPS, 1/2" qt., 80 micron
AB250C	3/4" NPS, 1 qt., 10 micron
AB250G	3/4" NPS, 1 qt., 80 micron
AB205	1/2" NPS, 1 qt., 80 micron
AB205E	1/2" NPS, 1 qt., 10 micron
FILTERS—plastic jar	
AA222N	1/2" NPS, 3/4" oz.
V400H	1/2" NPS, 8 oz.
V600H	3/4" NPS, 8 oz.
FLUSHING SOLVENT	
AP255	1 qt.
FOOT SUPPORT ASSEMBLIES	
AE216	0211, 0222, 0222
AE240	1/2" 1/4" hp piston pumps
AE241	1/2" 1/2" hp piston pumps
AE245	1/2" hp piston pumps

GAUGES—pressure	
AA242	1/2" NPS, 0-30 psi
AA244B	1/2" NPS, 0-30 psi 0-200cm ²
AA208	1/2" NPS, 0-100 psi (back mount)
AA207	1/2" NPS, 0-100 psi (back mount)
AP263	1/2" NPS, 0-100 psi, heavy duty (bottom mount)
GAUGES—vacuum	
AA240	1/2" NPS, 0-30" Hg, 0-760 mm Hg
AA241	1/2" NPS, 0-30" Hg
HANDLES—cylinder	
AP243	for 1/2" and 3/4" hp units
MUFFLERS—glass jar	
AB2906	3/4" NPS, 1 qt., 10 micron, for oil-less pumps
AB290C	1/2" NPS, 1 qt., 80 micron, for oil-less pumps
AB290J	1/2" NPS, 1 qt., 80 micron, for oil-less pumps
AD280	1" NPS, 2 qt., 80 micron
AB2908	1" NPS, 2 qt., 80 micron, with fitting for quieter operation
AA200F	3/4" NPS, 1 qt., 10 micron, for oil-less pumps
AA200G	3/4" NPS, 1 qt., 80 micron, for oil-less pumps
AA222B	1/2" NPS, 3/4" oz., 80 micron, for oil-less pumps
AA222B	same as AA222 but with silencing tube
AA217F	1/2" NPS, 2 oz., 80 micron, for oil-less pumps
MUFFLERS—metal jar	
AB212A	1/2" NPS, 1/2" qt., 10 micron
AB208B	1/2" NPS, 1/2" qt., 10 micron
AB208A	3/4" NPS, 1/2" qt., 10 micron
AB208C	1/2" NPS, 1 qt., 10 micron
AB2900	3/4" NPS, 1 qt., 10 micron
MUFFLERS—plastic jar	
AA222P	1/2" NPS, 3/4" oz.
V200H	1/2" NPS, 8 oz.
V250G	3/4" NPS, 8 oz.
OVERLOADS—motor	
	External thermal protector, specify motor number and make
PAINT	
AB244A	Black blue-gray, 16 oz. aerosol can
RELIEF VALVES—pressure	
AA220	1/2" NPS, flow below 2 cfm
AA206	1/2" NPS, flow below 2 cfm
AA200	3/4" NPS, flow below 10 cfm
AA207	1/2" NPS, flow above 10 cfm
AP270B	1/2" NPS, 0-100 psi
AP270	1/2" NPT, 0-100 psi
AE200	1" NPT, 0-100 psi
RELIEF VALVES—vacuum	
AA204	1/2" NPS, flow below 2 cfm
AA207	1/2" NPS, flow below 2 cfm
AA240A	3/4" NPS, flow from 2-10 cfm
AA208	3/4" NPS, flow above 10 cfm
AE261	1" NPS, for 02E2, 0205
SWITCH—vacuum	
AE265	1/2" NPS
TRAPS—vacuum	
AA270	3/4" NPS, 8 oz.
AA272B	1/2" NPS, 2 oz.
AA275C	1/2" NPS, 2 oz.

TROUBLE SHOOTING GUIDE FOR ROTARY VANE PUMPS

REASONS FOR PROBLEM	Low		High		Pump Overheating	Motor Overload
	Vac.	Press.	Vac.	Press.		
Filter dirty	X	X	at pump		X	X
Muffler dirty		X		at pump	X	X
Vac. line collapsed	X		at pump		X	X
Relief valve set too high			X	X	X	X
Relief valve set too low	X	X				
Plugged vacuum or pressure line	X	X	at pump	at pump	X	X
Vanes sticking	X	X				
Running at too high RPM			X	X	X	X
Vanes worn (replace)	X	X				
Shaft seal worn (replace)	X	X				
Dust or offset powder in pump	X	X			X	X
Motor not wired correctly	X	X			X	

Separate Drive Rotary Vane ^{8.5, 17.0} and 21.0 cfm



Oilless 1067, 2067, 2567 Series

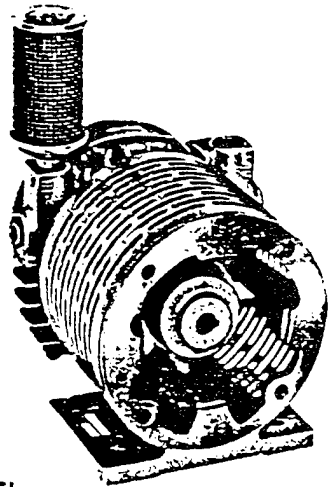

MODEL 1067 SERIES

15 PSI MAX. PRESSURE, 8.50 CFM OPEN FLOW

MODEL 2067 SERIES

15 PSI MAX. PRESSURE, 17.00 CFM OPEN FLOW

MODEL 2567 SERIES

15 PSI MAX. PRESSURE, 21.00 CFM OPEN FLOW

PRODUCT FEATURES

- Oilless operation
- Close coupled easy motor mounting
- Rugged construction/low maintenance
- Essentially pulse free service

INCLUDES

- Filter AA905F (1067), AA905G (2067/2567)
- Fan/coupling assembly AH198
- Fan guards AC102C, AH194

RECOMMENDED ACCESSORIES

- Pressure relief valve AA600 (1067), AA307 (2067/2567) (U.S. version)
- Pressure gauge AA644B (U.S. version)
- Repair kit K356 (1067)
- Repair kit K350 (2067/2567)

Important Notice:

Pictorial and dimensional data is subject to change without notice.

EUROPEAN MODEL

Product Dimensions Metric (mm)

Model	A	B	C	D	E	F	G	H	I	J	K	L	M	N
1067	195	100	144	72	288	180	102	11	125	165	241	142	19	80
2067	195	100	144	72	289	180	102	11	125	165	284	164	19	80
2567	195	100	144	72	289	180	102	11	125	165	284	164	19	80

U.S. MODEL

Product Dimensions Metric (mm) U.S. Imperial (inches)

Model	A	B	C	D	E	F	G	H	I	J	K	L	M	N
1067	195	145	287	180	132	102	11	124	165	241	142	495	21	76
1067	7.69	5.69	11.31	7.09	5.19	4.0	.44	4.88	6.50	9.50	5.59	19.50	.84	3.00
2067	194	145	287	180	132	102	11	124	165	284	164	584	21	76
2067	7.63	5.69	11.31	7.09	5.19	4.0	.44	4.88	6.50	11.19	6.44	23.00	.84	3.00
2567	194	145	287	180	132	102	11	124	165	284	164	584	21	76
2567	7.63	5.69	11.31	7.09	5.19	4.0	.44	4.88	6.50	11.19	6.44	23.00	.84	3.00

Dimensions for reference only.

METRIC MODEL

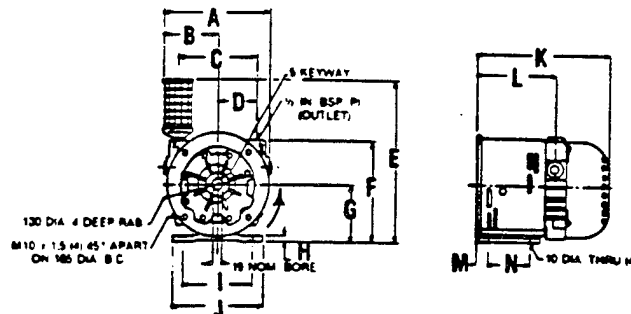

U.S./IMPERIAL MODELS NEMA 56, C FACE

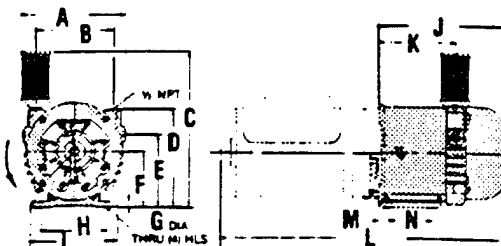

Product Specifications

Model Number	Motor	RPM		HP	kW	Net Wt.	
		60 cycle	50 cycle			lbs.	kg
1067-P102	Not included	1725	1425	1	0,75	34	15,40
1067-P104 (metric)	Not included	1725	1425	1	0,75	34	15,40
†1067-P106-G561X (like 1067-P102 plus motor)	110/220-240; 115/208-230; 50/60-1	1725	-	1	0,75	65	29,5
2067-P102	Not included	1725	1425	1	0,75	47	21,3
2067-P104 (metric)	Not included	1725	1425	1	0,75	47	21,3
†2067-P106-G561X (like 2067-P102 plus motor)	110/220-240; 115/208-230; 50/60-1	1725	-	1	0,75	92	41,7
2567-P102	Not included	1725	1425	2	1,5	46	20,9
2567-P104 (metric)	Not included	1725	1425	2	1,5	46	20,9
2567-P106-G475 (like 2567-P102 plus motor)	230/460-60-3	1725	-	2	1,5	81	36,8

†Motor includes Thermotector.

Product Performance (Metric U.S. Imperial) Black line on curve is for 60 cycle performance.
Blue line on curve is for 50 cycle performance.

Model 1067

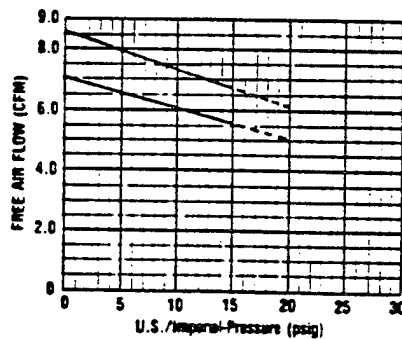
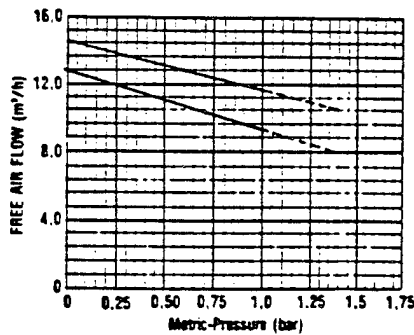

Model 2067

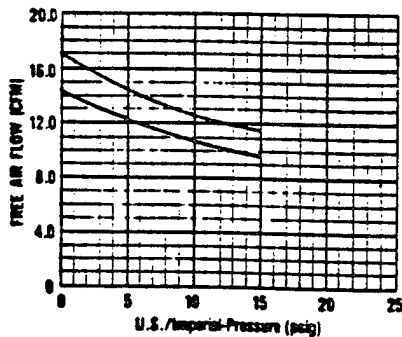
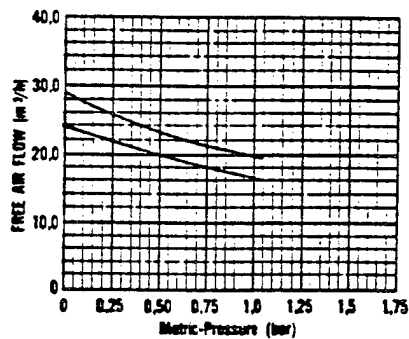

Model 2567

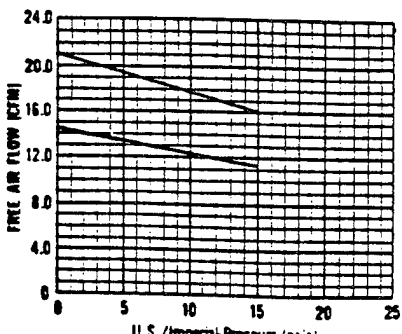
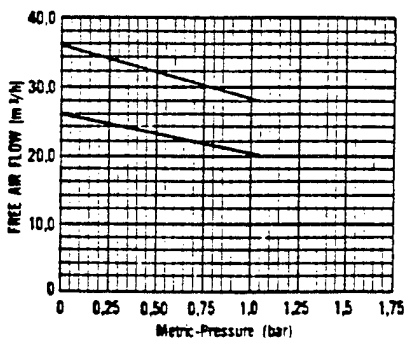

APPENDIX C
DATA COLLECTION SHEETS

APPENDIX C

CHAIN OF CUSTODY FORMS

CHAIN-OF-CUSTODY RECORD
Analytical Request

Client: Pace

Report To: MELANIE CONCEPCION

Pace Client No.

Address

Bill To:

Pace Project Manager

Phone

P.O. # / Billing Reference 75-3623
Project Name / No. McCLELLAN AFB

Pace Project No. 740520 502

*Requested Due Date: 6-3-94

Sampled By (PRINT):

Sampler Signature _____ Date Sampled _____

ITEM NO.	SAMPLE DESCRIPTION	TIME	MATRIX	PAGE NO.
1	CAP-VWI-21.5 (S-18)	S		
2	CAP-VWI-101 (S-19)	S		
3	CAP-VW2-100.5 (S-19)	S		
4				
5				
6				
7				
8				

NO. OF CONTAINERS	PRESERVATIVES				ANALYSES REQUEST
	UNPRESERVED	H ₂ SO ₄	HNO ₃	VOA	
1					TKN PHOS SOIL CLASS
1					
1					

9405FO9
REMARKS

AFCEE! -01
-02
-03

ITEM NUMBER	RELINQUISHED BY / AFFILIATION	ACCEPTED BY / AFFILIATION	DATE	TIME
		VIA FEO EX	5-24	1700

COOLER NOS.	BAILERS	SHIPMENT METHOD	RETURNED / DATE

Additional Comments

060064

AIR TOXICS LTD.
AN ENVIRONMENTAL ANALYTICAL LABORATORY

180 BLUE RAVINE ROAD, SUITE B
FOLSOM, CA 95630-4719
(916) 985-1000 FAX: (916) 985-1020

CHAIN-OF-CUSTODY RECORD

No. **006228**

Page **1** of **1**

Contact Person: ~~PARSONS~~ **MICHAEL PHELPS**
 Company: **PARSONS ES** ALAMEDA
 Address: **1301 MARINA VILL WILSON ST 2ND** State **CA** Zip **94521**
 Phone: **510 769 6100** FAX _____
 Collected By: Signature *Michael Phelps*

Project info:
 P.O. # **722406.36080**
 Project # **722406.36080**
 Project Name **Capenhant Gas Station**

Turn Around Time:
 Normal
 Rush _____ Specify _____

Lab I.D.	Field Sample I.D.	Date & Time	Analyses Requested	Canister Pressure / Vacuum	
				Initial	Final / Receipt
	CAP - CPI	11/13/95 1026	EPA TO-3 for TPH-g, BTEX		
	CAP - CP9	11/13/95 1054			
	CAP - CP2	11/13/95 1630			
	CAP - CP5	11/13/95 1036			
	CAP - CP3	11/13/95 1139			
	CAP - W1987-87	11/13/95 1133			
	CAP - W1987-6	11/13/95 1121			
	CAP - VNI	11/13/95 1200			
	CAP - CPA	11/13/95 1550			

Relinquished By: (Signature) *Michael Phelps* Date/Time **11/13/95 1600**
 Print Name **HILARY ECHLER**
 Received By: (Signature) _____ Date/Time _____
 Relinquished By: (Signature) _____ Date/Time _____
 Received By: (Signature) _____ Date/Time _____

Notes: **PLEASE FAX PRELIM. RESULTS TO MICHAEL PHELPS AT 510-769-9244**

Shipper Name _____ Air Bill # _____
 Opened By: _____ Date/Time _____
 Condition _____ Custody Seals Intact? _____
 Yes No None N/A
 Work Order # _____
 Lab Use Only

AIR TOXICS LTD.
AN ENVIRONMENTAL ANALYTICAL LABORATORY

180 BLUE RAVINE ROAD, SUITE B
FOLSOM, CA 95630-4719
(916) 985-1000 FAX: (916) 985-1020

CHAIN-OF-CUSTODY RECORD

No. 00052 Page 1 of 1

Contact Person: Michael Parsons
 Company: Parsons ES
 Address: 1301 Marine Village #200 City: Alameda State: CA Zip: 94501
 Phone: 510-769-0100 FAX: 510-769-7244
 Collected By: Signature M. Parsons

Project info: P.O. # 722466
 Project # 722466.36080
 Project Name McClellan AFB
Capavent Bioventing

Turn Around Time: Normal Rush Specify _____

Lab I.D.	Field Sample I.D.	Date & Time	Analyses Requested	Canister Pressure / Vacuum	
				Initial	Final
01A	CAP-CP9-10.5	11/28/95 1205	70-3 TPAH gasoline & BTEX	0" Hg	0" Hg
02A	CAP-CP10-15	11/28/95 1525		0" Hg	0" Hg
03A	CAP-CP10-30	11/28/95 1755		10" Hg	0" Hg
04A	CAP-CP11-10.5	11/29/95 0905		0" Hg	15" Hg
05A	CAP-CP11-28	11/29/95 1140		12/105 Hg	12/105 Hg
	used, Qty = 4		DO NOT ANALYZE		
	unused, Qty = 7				

Relinquished By: (Signature) [Signature] Date/Time 11/28/95 1205 Print Name Michael Parsons
 Relinquished By: (Signature) [Signature] Date/Time 11/28/95 1525 Print Name [Signature]
 Relinquished By: (Signature) [Signature] Date/Time 11/28/95 1755 Print Name [Signature]
 Relinquished By: (Signature) [Signature] Date/Time 11/29/95 0905 Print Name [Signature]
 Relinquished By: (Signature) [Signature] Date/Time 11/29/95 1140 Print Name [Signature]

Notes: FAX preliminary results to above contact.

Shipper Name: UPS Air Bill # Not Recorded Opened By: [Signature] Date/Time 12/15/97 1:00
 Condition: Good Custody Seals Intact? Yes No None N/A 9512045 Work Order # 9512045

Lab Use Only

APPENDIX D

**BIODEGRADATION
RATE CALCULATIONS**

Biodegradation Rate Calculations (Initial)

Site: Capehart Gas Station

Location: McClellan AFB, CA

	VW-1	CP-1	CP-3	CP-4	CP-5
	lab	lab	lab	lab	
user entered data					
Ko, oxygen utilization rate (%/hr)	0.29	0.24	0.13	0.10	0.28
w, moisture content (%)	16.2%	11.4%	17.5%	8.0%	15.0%
Soil type [from boring logs]	clayey SAND/ silty CLAY	silty SAND/ SAND	silty SAND/ SAND	silty SAND/ SAND	silty CLAY/ clayey SILT
Gravel fraction (% by wt.)	7.0%	0.0%	0.0%	0.0%	-
Sand fraction (% by wt.)	80.4%	90.8%	86.8%	91.8%	-
Silt fraction (% by wt.)	15.4%	8.2%	10.7%	6.2%	-
Clay fraction (% by wt.)	3.5%	1.0%	2.5%	2.0%	-
n, porosity (-) [est. from soil descriptions]	0.38	0.35	0.35	0.35	0.37
TPH-g contamination (mg/kg)	16	ND	1.3	ND	ND
TVH contamination (ppmv)	40,000	2,200	6,800	29,000	13,000
constants					
unit weight of water (g/cm ³)	1.0	1.0	1.0	1.0	1.0
G, spec. gravity of solids (- or g/cm ³)	2.65	2.65	2.65	2.65	2.65
Do, density of oxygen (mg/L)	1340	1340	1340	1340	1340
C, carbon/oxygen ratio	0.29	0.29	0.29	0.29	0.29
calculated data					
volume of solids, in 1 L of soil (cm ³)	0.62	0.65	0.65	0.65	0.63
volume of voids, in 1 L of soil (cm ³)	0.38	0.35	0.35	0.35	0.37
Dry unit weight (g/cm ³)	1.64	1.72	1.72	1.72	1.67
e, void ratio (-)	0.61	0.54	0.54	0.54	0.59
Sr, degree of saturation	0.70	0.56	0.86	0.39	0.68
volume of water, in 1 L of soil (cm ³)	0.27	0.20	0.30	0.14	0.25
volume of air, in 1 L of soil (cm ³)	0.11	0.15	0.05	0.21	0.12
wet density of soil (kg/L)	1.91	1.92	2.02	1.86	1.92
A, air filled porosity (liter air/kg wet soil)	0.060	0.080	0.024	0.114	0.062
Kb, biodegradation rate (mg TPH/kg soil per year)	580	640	100	380	580

Notes:

1. lab: soil sample was analyzed by analytical laboratory.
2. The following soil moisture contents were used: 17.5 % for CP-3 (average of previous investigation results and 15% for CP-5 (average of all site samples).

blcap.xls

2/23/86

Biodegradation Rate Calculations (One-Year)						
Site: Capehart Gas Station						
Location: McClellan AFB, CA						
	VW-1	CP-1	CP-3	CP-4	CP-5	
<u>user entered data</u>	lab	lab	lab	lab		
Ko, oxygen utilization rate (%/hr)	0.11	0.082	0.051	0.053	0.043	
w, moisture content (%)	16.2%	11.4%	17.5%	8.0%	15.0%	
Soil type [from boring logs]	clayey SAND/ silty CLAY	silty SAND/ SAND	silty SAND/ SAND	silty SAND/ SAND	silty CLAY/ clayey SILT	
Gravel fraction (% by wt.)	NS	NS	NS	NS	NS	
Sand fraction (% by wt.)	NS	NS	NS	NS	NS	
Silt fraction (% by wt.)	NS	NS	NS	NS	NS	
Clay fraction (% by wt.)	NS	NS	NS	NS	NS	
n, porosity (-) [est. from soil descriptions]	0.38	0.35	0.35	0.35	0.37	
TPH-g contamination (mg/kg)	NS	NS	NS	NS	NS	
TVH contamination (ppmv)	97	0.46	29	470	1.9	
<u>constants</u>						
unit weight of water (g/cm3)	1.0	1.0	1.0	1.0	1.0	
G, spec. gravity of solids (- or g/cm3)	2.65	2.65	2.65	2.65	2.65	
Do, density of oxygen (mg/L)	1340	1340	1340	1340	1340	
C, carbon/oxygen ratio	0.29	0.29	0.29	0.29	0.29	
<u>calculated data</u>						
volume of solids, in 1 L of soil (cm3)	0.62	0.65	0.65	0.65	0.63	
volume of voids, in 1 L of soil (cm3)	0.38	0.35	0.35	0.35	0.37	
Dry unit weight (g/cm3)	1.64	1.72	1.72	1.72	1.67	
e, void ratio (-)	0.61	0.54	0.54	0.54	0.59	
Sr, degree of saturation	0.70	0.56	0.86	0.39	0.68	
volume of water, in 1 L of soil (cm3)	0.27	0.20	0.30	0.14	0.25	
volume of air, in 1 L of soil (cm3)	0.11	0.15	0.05	0.21	0.12	
wet density of soil (kg/L)	1.91	1.92	2.02	1.86	1.92	
A, air filled porosity (liter air/kg wet soil)	0.060	0.080	0.024	0.114	0.062	
Kb, biodegradation rate (mg TPH/kg soil per year)	220	220	40	200	90	
<u>Notes:</u>						
1. lab: soil sample was analyzed by analytical laboratory.						
2. The following soil moisture contents were used: 17.5 % for CP-3 (average of previous investigation results and 15% for CP-5 (average of all site samples).						biocap.xls
						2/23/96