

LOAN DOCUMENT

PHOTOGRAPH THIS SHEET

①

DTIC ACCESSION NUMBER

LEVEL

INVENTORY

Operations + Maintenance Manual for the...

DOCUMENT IDENTIFICATION

Jan 97

DISTRIBUTION STATEMENT A
Approved for Public Release
Distribution Unlimited

DISTRIBUTION STATEMENT

ACCESSION FOR	
NTIS	GRAB
DTIC	TRAC
UNANNOUNCED	
JUSTIFICATION	
BY	
DISTRIBUTION/	
AVAILABILITY CODES	
DISTRIBUTION	AVAILABILITY AND/OR SPECIAL
<i>A-1</i>	

DISTRIBUTION STAMP

DATE ACCESSIONED

DATE RETURNED

20010117 032

DATE RECEIVED IN DTIC

REGISTERED OR CERTIFIED NUMBER

PHOTOGRAPH THIS SHEET AND RETURN TO DTIC-FDAC

H
A
N
D
L
E

W
I
T
H

C
A
R
E

**Operations and Maintenance Manual for the
Expanded-Scale Bioventing System at
Bulk POL Storage Area**



**Malmstrom Air Force Base
Montana**

Prepared For

**Air Force Center for Environmental Excellence
Technology Transfer Division
Brooks Air Force Base
San Antonio, Texas**

and

**341 CES/CEVR
Malmstrom Air Force Base
Montana**

January 1997



1700 Broadway, Suite 900 • Denver, Colorado 80290

AQ M01-03-0922

DEFENSE TECHNICAL INFORMATION CENTER REQUEST FOR SCIENTIFIC AND TECHNICAL REPORTS

Title AFCEE Collection

1. Report Availability (Please check one box)

- This report is available. Complete sections 2a - 2f.
- This report is not available. Complete section 3.

2a. Number of Copies Forwarded

1 each

2b. Forwarding Date

July/2000

2c. Distribution Statement (Please check ONE box)

DoD Directive 5230.24, "Distribution Statements on Technical Documents," 18 Mar 87, contains seven distribution statements, as described briefly below. Technical documents MUST be assigned a distribution statement.

- DISTRIBUTION STATEMENT A: Approved for public release. Distribution is unlimited.
- DISTRIBUTION STATEMENT B: Distribution authorized to U.S. Government Agencies only.
- DISTRIBUTION STATEMENT C: Distribution authorized to U.S. Government Agencies and their contractors.
- DISTRIBUTION STATEMENT D: Distribution authorized to U.S. Department of Defense (DoD) and U.S. DoD contractors only.
- DISTRIBUTION STATEMENT E: Distribution authorized to U.S. Department of Defense (DoD) components only.
- DISTRIBUTION STATEMENT F: Further dissemination only as directed by the controlling DoD office indicated below or by higher authority.
- DISTRIBUTION STATEMENT X: Distribution authorized to U.S. Government agencies and private individuals or enterprises eligible to obtain export-controlled technical data in accordance with DoD Directive 5230.25, Withholding of Unclassified Technical Data from Public Disclosure, 6 Nov 84.

2d. Reason For the Above Distribution Statement (in accordance with DoD Directive 5230.24)

2e. Controlling Office

HQ AFCEE

2f. Date of Distribution Statement Determination

15 Nov 2000

3. This report is NOT forwarded for the following reasons. (Please check appropriate box)

- It was previously forwarded to DTIC on (date) and the AD number is
- It will be published at a later date. Enter approximate date if known.
- In accordance with the provisions of DoD Directive 3200.12, the requested document is not supplied because:

Print or Type Name

Laura Peña

Signature

Laura Peña

Telephone

210-536-1431

(For DTIC Use Only)

AQ Number

M01-03-0922

PARSONS ENGINEERING SCIENCE, INC.

1700 Broadway, Suite 900 • Denver, Colorado 80290 • (303) 831-8100 • Fax: (303) 831-8208

February 4, 1997

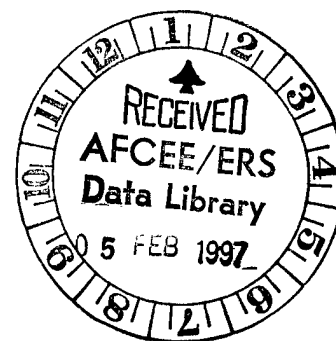

Captain Edward Marchand
AFCEE/ERT
3207 North Road, Bldg 532
Brooks AFB, TX 78235-5363

Subject: Operations and Maintenance Manual, Record Drawings, and Summary of Initial Results for the Expanded-Scale Bioventing System Installed at the Bulk Petroleum, Oils, and Lubricants (POL) Storage Area (Site PS-4), Malmstrom Air Force Base (AFB), Montana (Contract No. F41624-92-8036, Order 17)

Dear Captain Marchand:

This letter transmits three copies of the Operations and Maintenance (O&M) Manual prepared for the expanded-scale bioventing system recently installed at Site PS-4, the Bulk POL Storage Area (POL yard), Malmstrom AFB, Montana. Appendix A of the O&M Manual contains record drawings for the installed system. This letter also provides a summary of the work performed by Parsons Engineering Science, Inc. (Parsons ES) at the POL yard from October through December 1996, and presents initial system operating parameters and sampling results. Copies of this letter and the O&M Manual also have been sent to Mr. T. Dan Duff (Malmstrom AFB).

Summary of Field Activities

An expanded-scale bioventing system was installed at the POL yard at Malmstrom AFB by Parsons ES, and subcontractors under the supervision of Parsons ES, between October 2 and December 24, 1996. The system was installed as described in the *Final Remedial Action Plan (RAP) for Expanded Bioventing System, PS-4, Bulk POL Storage Area, Malmstrom AFB, Montana* (Parsons ES, 1996) with some exceptions, as discussed below. Figure 1 (attached) shows the site layout with the locations of the bioventing system components. Additional record drawings showing the final design details of the system components are provided in Appendix A of the attached O&M Manual.

Seventeen new air injection vent wells (VWs); 11 new soil gas monitoring points (MPs); a regenerative blower system; and associated piping, controls, and electrical service were installed during the autumn 1996 field mobilization. The expanded-scale system also utilizes one VW (VW1) and three soil gas MPs installed by Parsons ES in October 1993 under the AFCEE Bioventing Pilot Test Initiative (Engineering-Science, Inc., 1993; US Air Force, 1995). A new blower and blower shed were installed on a new concrete pad as described in the RAP (Parsons ES, 1996). Because the petroleum

contamination extended farther than expected, and because the vent well spacing was decreased from that proposed in the final RAP, five of the VWs and five of the MPs installed at the site were in addition to the scope proposed in the RAP. All of the new MPs, except MPD and MPG, were installed by Parsons ES in hand-augered boreholes. MPD and MPG were installed using a hollow-stem auger drill rig, as proposed in the final RAP.

In addition to the bioventing installation activities, natural chemical attenuation monitoring of groundwater quality was conducted at four new VWs installed with a portion of their screens below the perched saturated zone (VW14, VW16, VW17, and VW18), and at existing groundwater monitoring well MW-06 following the scope of work outlined in the letter from Parsons ES to AFCEE dated September 24, 1996.

Summary of Initial Sampling Results

Thirteen soil and seven soil gas samples were collected by Parsons ES for laboratory analysis during system installation. The soil samples were analyzed by Inchcape Testing Services, Inc. of Richardson, Texas for benzene, toluene, ethylbenzene, and xylenes (BTEX) using US Environmental Protection Agency (USEPA) Method SW8020, and for total extractable petroleum hydrocarbons (TEPH) and total volatile petroleum hydrocarbons (TVPH) using USEPA Method SW8015 modified. The soil gas samples were analyzed by Air Toxics, Ltd. of Folsom, California for BTEX and total volatile hydrocarbons (TVH) referenced to jet fuel using USEPA Method TO-3. In addition, soil gas samples were analyzed in the field by Parsons ES for oxygen, carbon dioxide, and TVH using direct-reading instruments. Soil and soil gas sampling results are summarized in Tables 1 and 2, respectively, and sampling locations are shown on Figure 1.

Generally, hydrocarbon contamination at the site is concentrated in the soil zone extending from a depth of approximately 2 feet below ground surface (bgs) to the perched groundwater surface, which was encountered at depths between approximately 2 and 7 feet bgs during VW installations. Depleted soil gas oxygen concentrations, which are indicative of hydrocarbon contamination, were measured in soil gas samples collected at depths below 3 feet bgs (Table 2). Higher soil gas oxygen concentrations measured at VW6 and VW7 are likely the result of short circuiting or ambient air leakage into the PVC well casing through the rubber "K" packer seal of the vapor monitoring apparatus.

Petroleum hydrocarbon concentrations were significant in soil and soil gas at VW3, VW4, VW5, VW6, VW8, VW9, VW11, VW17, MPD, MPF, MPG, MPI, MPJ, MPK, and MPL (Figure 1, Tables 1 and 2). Relatively low contaminant concentrations detected at VW16, VW18, and MPM indicate that the western and northwestern extent of contamination has been delineated, and that the effective treatment area of the bioventing system encompasses the majority of the hydrocarbon-contaminated soil in the vicinity of the former underground storage tanks (USTs). Future system expansion to the northeast and southeast may be required following abandonment of active areas of the POL yard. Meanwhile, implementation of a long-term groundwater monitoring

program (encompassing the entire POL yard and points downgradient) in support of a risk-based remedial approach is recommended to further document natural chemical attenuation processes occurring in groundwater at the site.

***In Situ* Respiration Rates**

To provide baseline data against which the progress of expanded-scale vadose zone remediation of fuel hydrocarbons can be evaluated, an *in situ* respiration test was performed at MPB-3.5, MPC-3.5, and MPD-4.5 on October 11 through October 13, 1996. This "area" respiration test was performed by injecting air (oxygen) into VW1 using the existing pilot-scale blower system for an 8-day period. After system shut-down, oxygen loss and other changes in soil gas composition over time were measured at MPB, MPC, and MPD. Oxygen, carbon dioxide, and TVH were measured for a period of approximately 3 days following air injection. The measured oxygen losses then were used to calculate biological oxygen utilization rates. Respiration results for this and earlier tests are summarized in Table 3.

Results from the *in situ* respiration test indicate significant biodegradation can be induced in these soils by providing oxygen. Oxygen utilization rates measured at MPB and MPC were moderate, ranging from 0.64 percent per hour at MPB-3.5 to 0.91 percent per hour at MPC-3.5. At MPD-4.5, the oxygen increased from 7.9 percent to 16.7 percent following system shut-down. This indicates that the injected air may have continued migration outward from VW1 into the area of MPD after the beginning of the respiration test. Another explanation could be that atmospheric oxygen diffused through the loose gravel surface to the shallow MP screened interval. MPA-3.5 was submerged in perched groundwater during the October 1996 testing.

Based on these oxygen utilization rates, an estimated 400 to 1,100 milligrams (mg) of fuel per kilogram (kg) of soil can be degraded each year at this site. This conservative estimate is based on an average air-filled volume of approximately 0.07 liter per kg of soil, and a ratio of 3.5 mg of oxygen consumed for every 1 mg of fuel biodegraded. Actual degradation rates may vary and will likely decrease with time as the more easily degraded BTEX compounds are preferentially destroyed over more biologically recalcitrant hydrocarbon compounds.

Initial Operation Parameters

The expanded-scale bioventing system was started on October 22, 1996. The air injection rate for each VW was adjusted to approximately 0.5 to 3.1 cubic feet per minute (cfm). Air flow adjustments were made periodically during the following 2 months until the system approached equilibrium flow rates of 1 to 4.9 cfm for each VW (Table 4). The corresponding air injection pressure was 93 inches of water. During this time, pressure responses measured at the MPs ranged from a maximum of 5 inches of water at MPF and MPG at a depth of 4 feet, to no response at several of the MPs that were submerged under groundwater. Groundwater surface measurements collected prior to and following system startup indicate that the groundwater level is being depressed locally by air injection, exposing a greater thickness of unsaturated

soils for treatment (Table 4). It is anticipated that prolonged air injection will depress groundwater throughout the site, and that smear zone soils will be treated. Based on the positive oxygen influence data (Table 5), it appears that the low air injection flow rates at the site are sufficient to provide oxygen to the entire targeted area. Future soil gas monitoring should be conducted at MPG and MPL (which were flooded during the October 1996 testing) to verify that these areas are receiving sufficient oxygen supply.

Oxygen, carbon dioxide, and TVH soil gas concentrations also were measured at the MPs before and after system start-up to determine the volume of soil being oxygenated by the expanded-scale bioventing system. Table 5 provides the oxygen influence data for the site. Soil gas oxygen monitoring results indicate that the effective treatment radius exceeds 35 feet throughout the site, and that the entire volume of soil with significant hydrocarbon contamination is being oxygenated. Monitoring at MPN-5.5 indicates that the effective treatment radius may exceed 50 feet in some locations.

Potential Vapor Migration

The long-term potential for volatile organic compound (VOC) air emissions from expanded-scale bioventing operations at this site is considered low because of the age of the site contaminants (greater than 5 years); the very low air injection flow rates (1-4 cfm per VW); and the asphalt cover. Air emissions are expected to be minimal because accumulated vapors will move slowly outward from the air injection points and will be biodegraded as they move horizontally through the soil.

Air emissions monitoring was conducted during expanded-scale system startup at nine locations using a photoionization detector (PID) sensitive to 1 ppmv organic vapors. The PID was calibrated using hydrocarbon-free air. Because the potential for air emissions is highest during the initial hours of injection, and because no VOC emissions were detected, the long-term emission potential is considered low.

Natural Attenuation Monitoring

Groundwater sampling in support of natural chemical attenuation was conducted at five site wells (MW-06, VW14, VW16, VW17, and VW18) on October 18, 1996. Each well was sampled for the following analytes: dissolved oxygen, total alkalinity, chloride, sulfate, hydrogen sulfide, ferrous iron, total iron, nitrate, nitrite, carbon dioxide, manganese, methane, BTEX, trimethylbenzenes, and TVPH. Tables 6 and 7 contain the results of the groundwater sampling. Based on trends observed at Pumphouse 2, it appears that BTEX compounds are biodegrading in saturated soils and groundwater at the POL yard via oxygen reduction, manganese reduction, ferric iron reduction, sulfate reduction, and methanogenesis.

Site Recommendations

Based on the positive results from preliminary operation of the expanded-scale system, the following recommendations are proposed to attain cleanup goals:

- Continued bioventing system operation with annual respiration testing/soil gas sampling to determine remedial progress; and
- Site closure soil sampling after respiration rates approach background rates.

If you have any questions or comments regarding the information contained in this letter or in the enclosed O&M Manual, please contact either of us at (303) 831-8100.

Sincerely,

PARSONS ENGINEERING SCIENCE, INC.



John Ratz, P.E.
Project Manager



David Teets
Site Manager

Attachments: References, Figure 1, Tables 1-7

Enclosure: O&M Manual

cc: T. Dan Duff, Jim Hodges (Malmstrom AFB)
Diana Tanner, Parsons ES - Austin (w/o enclosure)
File 726876.38130

References

Engineering-Science, Inc. 1993. *Part I, Bioventing Pilot Test Work Plan and Part II, Draft Interim Pilot Test Results Report for PS-3 (Pumphouses 2 and 3) and PS-4 (Bulk POL Storage Area). Malmstrom Air Force Base, Montana.* December.

Parsons Engineering Science, Inc. 1996. *Final Remedial Action Plan for Expanded Bioventing System, PS-4, Bulk POL Storage Area.* September.

United States Air Force. 1995. Memorandum for 43 CES/CEVR, Malmstrom Air Force Base, concerning bioventing pilot test results at PS-3 (Pumphouse 2) and PS-4 (Bulk POL Storage Area).

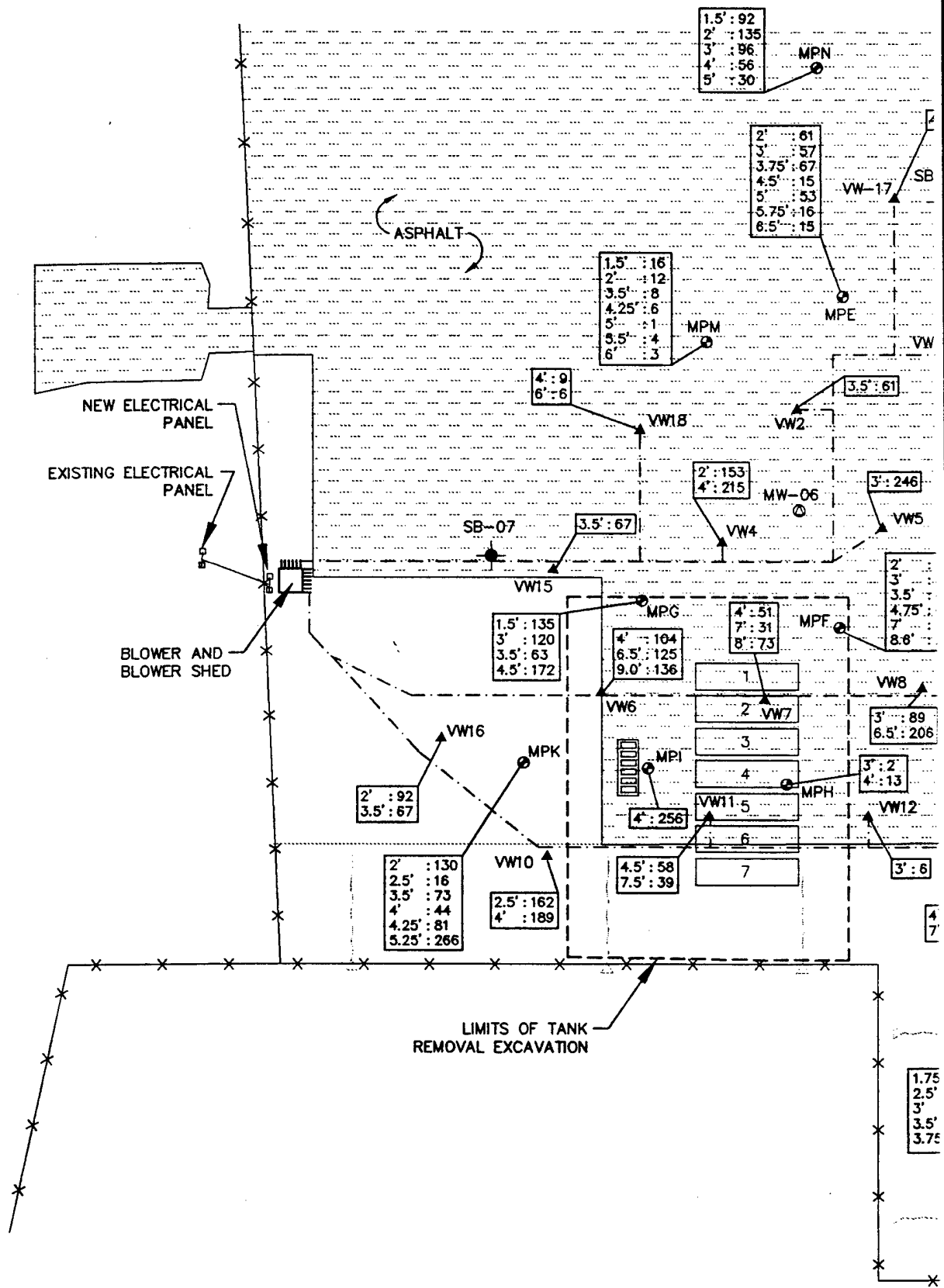

①

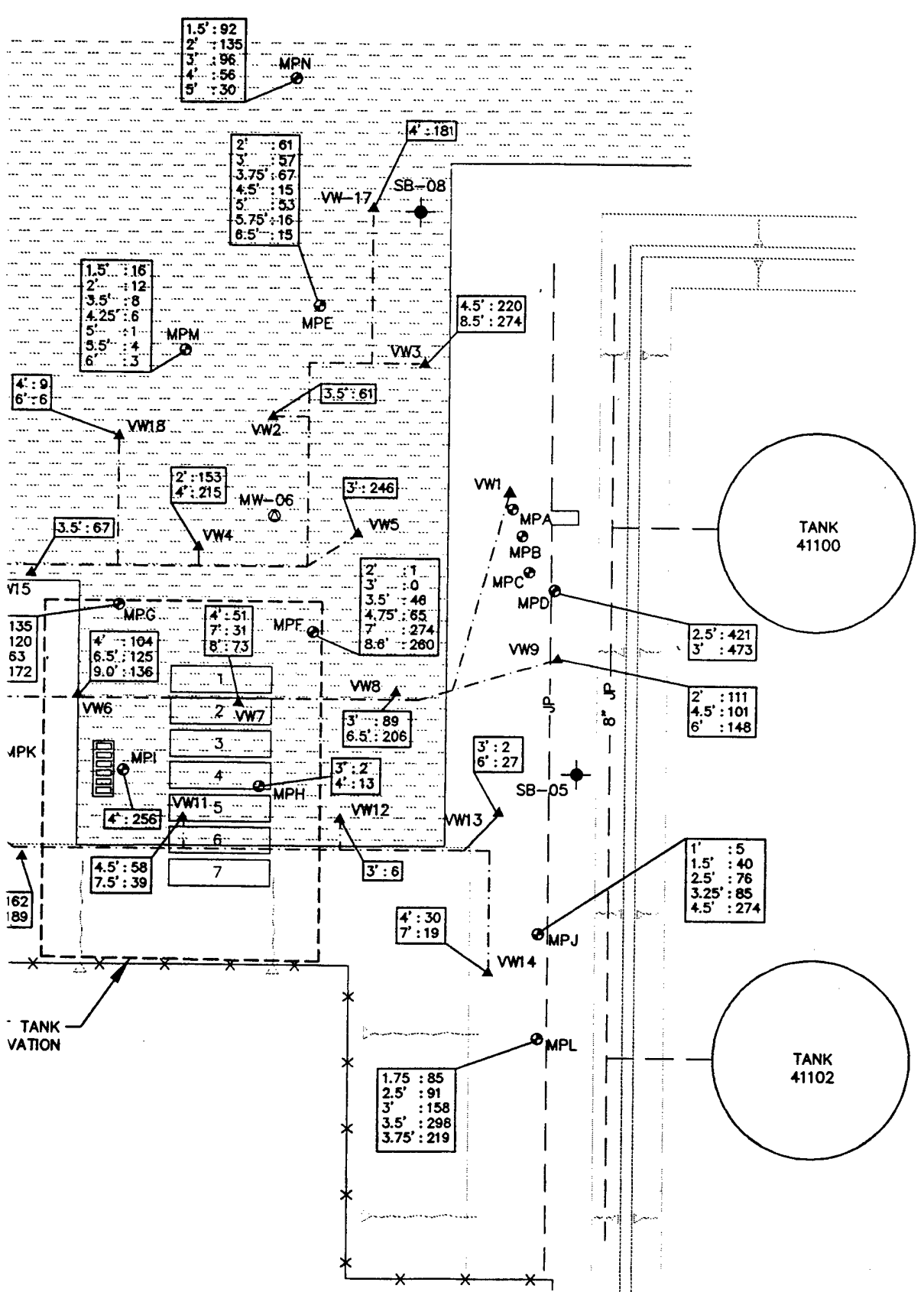

LEGE

- ⊙ GRC
- ⊕ BIO
- ▲ VEN
- ⊙ PRE
- SLO
- - - HEA
- * * * FEN
- 4' : 181 SOIL DETE

**PAR
ENGI**

.....

LEGEND

- ⊙ GROUNDWATER MONITORING WELL
- ⊕ BIOVENTING MONITORING WELL
- ▲ VENT WELL
- ⊙ PREVIOUS SOIL BORING
- ▭ SLOPE
- - - - - HEADER PIPE TO VENT WELL
- x-x- FENCE
- 4' : 181 SOIL SAMPLE DEPTH : PHOTOIONIZATION
DETECTOR FIELD MEASUREMENT (ppmv)

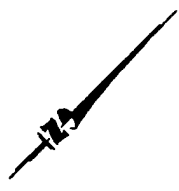
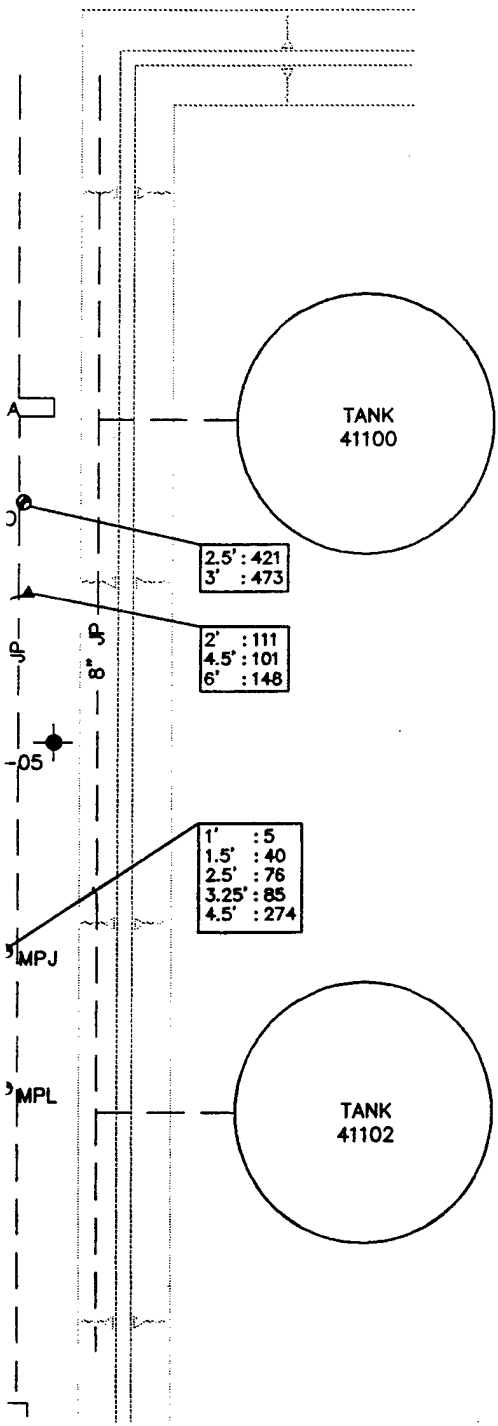

FIGURE 1

**AS-BUILT SITE PLAN
PS-4, BULK POL
STORAGE AREA**

Expanded Bioventing System
POL Yard
Malmstrom AFB, Montana

**PARSONS
ENGINEERING SCIENCE, INC.**

Denver, Colorado

TABLE 1
SOIL ANALYTICAL DATA
PS-4, BULK POL STORAGE AREA
MALMSTROM AFB, MONTANA

Analyte	Units	Sampling Location and Starting Depth (feet bgs) ^{a/}												
		VW4: 3.5'	VW5: 3'	VW9: 6'	VW10: 4'	VW11: 4.5'	VW12: 3'	VW15: 3.5'	VW16: 2'	VW18: 4'	MPP: 7'	MPL: 3'	MPM: 6'	MPN: 4'
Field PID Headspace Reading	ppmv ^{b/}	215	246	148	189	58	7	67	92	8	274	158	3	56
TVPH-Gasoline	mg/kg ^{c/}	5,120	11,500	835	104	226	0.162	57.1	52.2	0.574	575	1,950	0.464	1.62
TEPH-Diesel	mg/kg ^{c/}	90.5	509	163	90.6	112	10.0 U ^{d/}	33.1	10.0 U	10.0 U	11.6	675	10.0 U	10.0 U
Benzene	µg/kg ^{e/}	9,700 J ^{f/}	20,000 U	1,000 U	200 U	100 U	2.0 U	50 U	50 U	2.0 U	1,000 U	2,000 U	2.0 U	2.0 U
Toluene	µg/kg	10,000 U	20,000 U	1,000 U	200 U	100 U	2.0 U	50 U	50 U	2.0 U	1,000 U	8,800	1.6 J	2.0 U
Ethylbenzene	µg/kg	83,400	73,000	4,610	840	733	2.0 U	95	261	4.3	6,990	6,600	2.8	9.8
Total Xylenes (o,m,p)	µg/kg	364,000	329,000	10,700	4,620	534	2.0 U	880	525	16.5	26,900	14,700	29.0	29.0

^{a/} bgs = below ground surface. Starting depth = Soil sample beginning depth.

^{b/} ppmv= parts per million, volume per volume.

^{c/} mg/kg = milligrams per kilogram of soil.

^{d/} U= Compound analyzed for, but not detected above the method detection limit.

^{e/} µg/kg = micrograms per kilogram of soil.

^{f/} J= Indicates a laboratory estimated value. This flag is used if the compound is detected but is below the reporting limit.

TABLE 2
SOIL GAS ANALYTICAL DATA
PS-4, BULK POL STORAGE AREA
MALMSTROM AFB, MONTANA

Sampling Location-Depth (feet bgs) ^{c/}	Initial Field Screening Data			Laboratory Analytical Results				
	O ₂ (%)	CO ₂ (%)	Field TVH ^{a/} (ppmv ^{d/})	Benzene (ppmv)	Toluene (ppmv)	Ethylbenzene (ppmv)	Total Xylenes (ppmv)	TVPH ^{b/} (ppmv)
MPA-3.5	NS ^{e/}	NS	NS	NS	NS	NS	NS	NS
MPB-3.5	0.0	>15	>20,000	NS	NS	NS	NS	NS
MPC-3.5	0.0	>15	>20,000	NS	NS	NS	NS	NS
MPD-4.5	0.0	15.1	>20,000	310	140	37	150	81,000 B ^{f/}
MPE-4.5	4.0	15	NS	NS	NS	NS	NS	NS
MPF-4.5	1.9	>25	>20,000	150	69	26	79	68,000 B
MPF-8	NS	NS	NS	NS	NS	NS	NS	NS
MPG-3.5	4.2	15	21,600	44	61	26	86 M ^{g/}	24,000 B
MPG-5.5	NS	NS	NS	NS	NS	NS	NS	NS
MPH-3.5	NS	NS	NS	NS	NS	NS	NS	NS
MPI-3.5	1.2	25	>40,000	NS	NS	NS	NS	NS
MPJ-4	2.0	19.9	>20,000	NS	NS	NS	NS	NS
MPK-4.5	NS	NS	NS	NS	NS	NS	NS	NS
MPL-3	1.6	15.3	>20,000	NS	NS	NS	NS	NS
MPM-4.5	0.0	15.2	6,000	1.3	1.4	0.29 U ^{h/}	2.8 M	3,800 B
MPN-5.5	0.0	12	>40,000	78	36	17	150 M	41,000 B
VW6	18.9	1.5	20,000	16	10	4.2	12 M	10,000 B
VW7	17.9	4.4	9,600	20	9.5	2.4	17 M	11,000 B

^{a/} TVH = total volatile hydrocarbons.

^{b/} TVPH = total volatile petroleum hydrocarbons, referenced to jet fuel.

^{c/} bgs = below ground surface.

^{d/} ppmv = parts per million, volume per volume.

^{e/} NS = No sample collected; soils were either too tight or MP was flooded.

^{f/} B= Compound present in laboratory blank at a concentration of 0.028 ppmv, background subtraction not performed.

^{g/} M= Reported value may be biased due to apparent matrix interferences.

^{h/} U = Compound analyzed for, but not detected above the method detection limit shown.

TABLE 3
RESPIRATION AND DEGRADATION RATES
PS-4, BULK POL STORAGE AREA
MALMSTROM AIR FORCE BASE, MONTANA

Sampling Location-Depth (feet below ground surface)	Pilot-Scale Test								Expanded-Scale	
	Initial (October 1993)		6-Month ^{a/} (April 1994)		12-Month ^{b/} (October 1994)		Initial ^{c/} (October 1996)		Degradation Rate (mg/kg/year)	Degradation Rate (mg/kg/year)
	O ₂ Utilization (% O ₂ /hour)	Degradation Rate (mg/kg/year) ^{d/}	O ₂ Utilization (% O ₂ /hour)	Degradation Rate (mg/kg/year)	O ₂ Utilization (% O ₂ /hour)	Degradation Rate (mg/kg/year)	O ₂ Utilization (% O ₂ /hour)	Degradation Rate (mg/kg/year)		
MPA-3.5	0.6	420	0.192	190	NS ^{e/}	NS	NS	NS	NS	NS
MPB-3.5	1.68	1100	0.444	450	0.252	300	0.638	430		
MPC-3.5	1.08	720	0.396	400	0.246	290	0.908	610		

^{a/} Assumes moisture content of the soil is average of initial and final measured moisture content.

^{b/} An "area" respiration test was performed by restarting the blower for approximately 47 hours to provide oxygen to soils.

^{c/} An "area" respiration test was performed by restarting the blower for approximately 8 days to provide oxygen to soils. The blower was not operated during the period from October 1994 through October 1996.

^{d/} Milligrams of hydrocarbons per kilogram of soil per year.

^{e/} NS = Not sampled. MPA-3.5 was screened below the perched groundwater surface.

TABLE 4
INITIAL AND FINAL AIR FLOW RATES AND GROUNDWATER DEPTHS
PS-4, BULK POL STORAGE AREA
MALMSTROM AFB, MONTANA

Monitoring Location	Initial Groundwater Depth (ft btoc) ^{a/}	Initial Air Velocity (fpm ^{b/})	Initial Flow Rate (acfm) ^{c/d/}	Final Groundwater Depth (ft btoc) ^{e/}	Final Air Velocity (fpm) ^{f/}	Final Flow Rate (acfm) ^{f/}
VW1	4.45	190	2.3	6.34	300	3.7
VW2	6.95	250	3.1	8.47	310	3.8
VW3	7.01	150	1.8	8.36	390	4.8
VW4	5.41	190	2.3	7.92	400	4.9
VW5	3.91	250	3.1	8.70	310	3.8
VW6	6.21	75	0.9	9.05	90	1.1
VW7	2.81	100	1.2	7.40	300	3.7
VW8	7.58	150	1.8	7.75	250	3.1
VW9	6.32	210	2.6	7.72	400	4.9
VW10	1.09	105	1.3	7.90	200	2.5
VW11	6.29	40	0.5	6.86	70	0.9
VW12	5.25	90	1.1	8.55	175	2.1
VW13	4.40	150	1.8	4.05	310	3.8
VW14	6.31	100	1.2	7.05	325	4.0
VW15	5.55	155	1.9	6.54	250	3.1
VW16	2.77	210	2.6	7.54	350	4.3
VW17	6.48	200	2.5	8.02	375	4.6
VW18	4.88	230	2.8	8.27	175	2.1
Total Blower Output			34.9			61.1

^{a/} ft btoc = feet below top of casing. Groundwater measurement collected on October 28, 1996.

^{b/} fpm = feet per minute. Pipe diameter = 1.5 inches.

^{c/} acfm = actual cubic feet per minute.

^{d/} Blower performance on November 15, 1996: Pressure= 114"H₂O; Vacuum= 5.9"H₂O; Temperature= 155 degrees Fahrenheit.

^{e/} Groundwater level measurement collected on November 1, 1996.

^{f/} Blower performance on December 24, 1996: Pressure= 93"H₂O; Vacuum= 8.4"H₂O; Temperature= 108 degrees Fahrenheit.

TABLE 5
OXYGEN INFLUENCE MONITORING
PS-4, BULK POL STORAGE AREA
MALMSTROM AFB, MONTANA

Sampling Location-Depth (feet bgs) ^{c/}	O ₂ (%)			CO ₂ (%)			Field TVH ^{a/} (ppmv ^{b/})		
	Initial	18-Day	54-Day	Initial	18-Day	54-Day	Initial	18-Day	54-Day
MPA-3.5	NS ^{d/}	NS	NS	NS	NS	NS	NS	NS	NS
MPB-3.5	0.0	16.9	NC ^{e/}	>15	3.4	NC	>20,000	560	NC
MPC-3.5	0.0	11.0	NC	>15	6.1	NC	>20,000	4,800	NC
MPD-4.5	0.0	5.3	NC	15.1	9.3	NC	>20,000	18,400	NC
MPE-4.5	4.0	20.3	20.4	15	0.3	0.2	NC	2,500	NC
MPF-4.5	1.9	19.0	4.0	>25	3.2	>15	>20,000	NS	>10,000
MPF-8	NS	NS	NS	NS	NS	NS	NS	NS	NS
MPG-3.5	4.2	0.0	0.0	15	10.8	9.3	21,600	>20,000	19,000
MPG-5.5	NS	NS	NS	NS	NS	NS	NS	NS	NS
MPH-3.5	NS	NS	NS	NS	NS	NS	NS	NS	NS
MPI-3.5	1.2	2.0	4.0	25	15.9	13.0	>40,000	3,200	3,000
MPJ-4	2.0	14.0	15.0	19.9	2.3	9.0	>20,000	>20,000	NC
MPK-4.5	NS	NS	NS	NS	NS	NS	NS	NS	NS
MPL-3	1.6	0.0	NS	15.3	9.2	NS	>20,000	>20,000	NS
MPM-4.5	0.0	14.1	17.8	15.2	2.2	1.8	6,000	1,200	200
MPN-5.5	0.0	0.4	9.0	12	4.5	3.0	>40,000	13,600	12,500

^{a/} TVH = total volatile hydrocarbons.

^{b/} ppmv = parts per million, volume per volume.

^{c/} bgs = below ground surface.

^{d/} NS = No sample collected; soils were either too tight or MP was flooded.

^{e/} NC = No sample collected or sufficient sample volume not obtainable for all field analyses.

TABLE 6
GROUNDWATER GEOCHEMICAL DATA
PS-4, BULK POL STORAGE AREA
MALMSTROM AFB, MONTANA

Sampling Location	Date	Temperature (°C)	Conductivity (mS/cm)	Dissolved Oxygen (mg/L)	Total Alkalinity (mg/L)	pH	Chloride (mg/L)	Sulfate (lab) (mg/L)	Hydrogen Sulfide (mg/L)	Ferrous Iron (mg/L)	Total Iron (mg/L)	Nitrate (mg/L)	Nitrite (mg/L)	CO ₂ (mg/L)	Mn ²⁺ (mg/L)	Methane (mg/L)
MW-06	10/18/96	16.4	2.10	0.29	1000	6	10.9	2	0.019	0.63	1.02	<0.056 ^a	<0.076	180	2.6	0.93
VW-14	10/18/96	13.8	4.46	0.67	2200	6	82.6	1190	0.041	0.07	0.16	<0.056	<0.076	300	0.600	0.019
VW-16	10/18/96	15.2	1.94	0.50	1090	6	32.1	61.6	0.018	3.71	9.95	<0.056	<0.076	160	5.3	2.8
VW-17	10/18/96	17.4	1.29	0.29	1037	5.5	27.4	260	0.078	3.07	>5.10	<0.056	<0.076	160	2.450	0.47
VW-18	10/18/96	16.5	1.39	1.06	660	6	26.3	14.6	0.033	0.8	0.73	<0.056	<0.076	130	2.1	1.08
MW-4 ^b (Background)	11/11/94	12.2	2.47	7.40	480	7.2	NA ^c	1332	<0.024	0.01	0.01	2.6	<0.005	105	0.3	NA

^a < = Concentration below method detection limit.

^b Background monitoring well MW-4 located at Pumphouse 2.

^c NA = Not analyzed.

TABLE 7
GROUNDWATER ANALYTICAL DATA
PS-4, BULK POL STORAGE AREA
MALMSTROM AFB, MONTANA

Sampling Location	Date	Benzene (µg/L) ^d	Toluene (µg/L)	Ethylbenzene (µg/L)	Total Xylenes (µg/L)	Total BTEX (µg/L)	1,3,5-TMB ^a (µg/L)	1,2,4-TMB (µg/L)	1,2,3-TMB (µg/L)	1,2,3,4-TEMB ^b (µg/L)	TVPH (mg/L) ^d
MW-06	10/18/96	16,000	5,400	1,800	8,500	31,700	91	350	130	72	58
VW-14	10/18/96	370	76	66	160	672	12	99	35	23	6.4
VW-16	10/18/96	54	2,100	240	1,900	4,294	46	75	66	83	9.5
VW-17	10/18/96	48	9.8	36	190	283.8	13	29	18	5.9	4.0
VW-18	10/18/96	140	21	140	480	781	88	180	180	100	4.3

^a TMB = trimethylbenzene.

^b TEMB = tetramethylbenzene.

^c µg/L = microgram per liter.

^d mg/L = milligram per liter.

CONTENTS

	<u>Page</u>
SECTION 1 - INTRODUCTION	1-1
SECTION 2 - SYSTEM DESCRIPTION	2-1
2.1 Blower System.....	2-1
2.2 Monitoring and Flow Control Equipment	2-1
2.2.1 Monitoring Gauges	2-1
2.2.2 Flow Control Equipment	2-1
SECTION 3 - SYSTEM MAINTENANCE.....	3-1
3.1 Blower/Motor.....	3-1
3.2 Air Filter	3-1
3.3 Maintenance Schedule.....	3-2
3.4 Major Repairs	3-2
SECTION 4 - SYSTEM MONITORING.....	4-1
4.1 Blower Performance Monitoring	4-1
4.1.1 Vacuum	4-1
4.1.2 Temperature	4-1
4.1.3 Pressure.....	4-1
4.1.4 Air Flow Rate Measurements.....	4-1
4.2 Monitoring Schedule	4-1
APPENDICES	
APPENDIX A - Record Drawings	
APPENDIX B - Regenerative Blower Information	
APPENDIX C - Data Collection Sheets	

TABLES

	<u>Page</u>
2.1 Initial and Final Air Flow Rates.....	2-2

SECTION 1

INTRODUCTION

This operations and maintenance (O&M) manual has been created as a guide for monitoring and maintaining the performance of the expanded-scale bioventing blower system at the Bulk Petroleum, Oils, and Lubricants (POL) Storage Area (POL yard), Malmstrom Air Force Base (AFB), Montana. This site is located in the northeastern portion of the base. Record drawings for the expanded-scale bioventing system, installed at the POL yard (Site PS-4) in October 1996 in accordance with the site remedial action plan, are provided in Appendix A of this O&M manual.

At this site, bioventing is the forced injection of fresh air to enhance the supply of oxygen in subsurface soils for *in situ* bioremediation. A blower system is used to inject air into the soil, thereby supplying fresh atmospheric air (with approximately 20.8 percent oxygen) to contaminated soils. Once oxygen is provided to the subsurface, indigenous aerobic bacteria biodegrade fuel residuals. Aerobic biodegradation of fuel compounds in soil is much more efficient than anaerobic biodegradation, which occurs in oxygen-depleted soils.

Parsons Engineering Science, Inc. (Parsons ES) has installed an air injection bioventing system consisting of one air injection blower, 18 vent wells (VWs), 15 soil gas monitoring points (MPs), and associated piping at the site. The blower at the POL yard was started in October 1996, and the injection rates into each VW were optimized over a 2-month period to ensure adequate aeration of contaminated soils.

Malmstrom AFB personnel are responsible for routine monitoring of the bioventing system. Parsons ES has trained Malmstrom AFB environmental personnel on the monitoring requirements of this plan. If significant problems are encountered with the operation of the system, Parsons ES should be notified so that recommendations on repairs can be made. Under the AFCEE Extended Bioventing Project, Parsons ES is no longer contractually responsible for system repair or operation.

SECTION 2

SYSTEM DESCRIPTION

2.1 Blower System

A Gast® R6P355R-50 regenerative blower powered by a 6-horsepower direct-drive motor was installed at the POL yard. The R6P blower is rated for a flow rate of 135 standard cubic feet per minute (scfm) at a pressure of 85 inches of water; however, the actual performance of the blower will vary with changing site conditions. Table 2.1 presents the flow rate into each of the injection VWs in actual cubic feet per minute (acfm). The blower system includes an inlet air filter to remove any particulate matter which may be entrained in the inlet air stream, and several valves and monitoring gauges, which are described in Section 2.2. An as-built schematic of the expanded-scale blower system installed at the POL yard is shown in Appendix A. Corresponding blower performance curves and relevant service information are provided in Appendix B.

2.2 Monitoring and Flow Control Equipment

2.2.1 Monitoring Gauges and Ports

The bioventing system is equipped with one vacuum gauge, one pressure gauge, and one temperature gauge. The vacuum gauge is located on the inlet piping between the air filter and the blower and the temperature and pressure gauges are located on the outlet piping. Each individual VW manifold pipe has one air velocity measurement port (i.e., each VW has its own individual flow measurement port). Refer to the record drawings in Appendix A for exact gauge and port locations.

2.2.2 Flow Control Equipment

Manual and automatic pressure relief valves (PRVs) and flow control valves (FCVs) have been installed on the bioventing blower system. A manual FCV, or bleed valve, has been installed in the outlet piping leading to each VW, allowing the flow rate to each VW to be manually adjusted. An automatic FCV, or PRV, is used to protect each blower system from burning out if pressure rises due to pipe blockage. The PRV is set to bleed off flow at a preset pressure, and thus will prevent blower outlet pressure from exceeding the rated pressure.

TABLE 2.1
INITIAL AND FINAL AIR FLOW RATES AND GROUNDWATER DEPTHS
PS-4, BULK POL STORAGE AREA
MALMSTROM AFB, MONTANA

Monitoring Location	Initial Groundwater Depth (ft btoc) ^{a/}	Initial Air Velocity (fpm) ^{b/}	Initial Flow Rate (acfm) ^{c/}	Final Groundwater Depth (ft btoc) ^{e/}	Final Air Velocity (fpm) ^{f/}	Final Flow Rate (acfm) ^{f/}
VW1	4.45	190	2.3	6.34	300	3.7
VW2	6.95	250	3.1	8.47	310	3.8
VW3	7.01	150	1.8	8.36	390	4.8
VW4	5.41	190	2.3	7.92	400	4.9
VW5	3.91	250	3.1	8.70	310	3.8
VW6	6.21	75	0.9	9.05	90	1.1
VW7	2.81	100	1.2	7.40	300	3.7
VW8	7.58	150	1.8	7.75	250	3.1
VW9	6.32	210	2.6	7.72	400	4.9
VW10	1.09	105	1.3	7.90	200	2.5
VW11	6.29	40	0.5	6.86	70	0.9
VW12	5.25	90	1.1	8.55	175	2.1
VW13	4.40	150	1.8	4.05	310	3.8
VW14	6.31	100	1.2	7.05	325	4.0
VW15	5.55	155	1.9	6.54	250	3.1
VW16	2.77	210	2.6	7.54	350	4.3
VW17	6.48	200	2.5	8.02	375	4.6
VW18	4.88	230	2.8	8.27	175	2.1
Total Blower Output			34.9			61.1

^{a/} ft btoc = feet below top of casing. Groundwater measurement collected on October 28, 1996.

^{b/} fpm = feet per minute. Pipe diameter = 1.5 inches.

^{c/} acfm = actual cubic feet per minute.

^{d/} Blower performance on November 15, 1996: Pressure= 114"H₂O; Vacuum= 5.9"H₂O; Temperature= 155 degrees Fahrenheit.

^{e/} Groundwater level measurement collected on November 1, 1996.

^{f/} Blower performance on December 24, 1996: Pressure= 93"H₂O; Vacuum= 8.4"H₂O; Temperature= 108 degrees Fahrenheit.

An additional FCV (bleed valve) has been installed to control the total air flow out of the blower by releasing excess air flow to the atmosphere. All of the FCVs have been set by Parsons ES personnel to deliver a calculated amount of air to each VW, and should not be adjusted.

As discussed in Section 2.2.1, each manifold pipe leading to an individual VW has also been equipped with a flow measurement port. These ports consist of brass bushings installed in the outlet piping inside the blower shed. These bushings, which should be capped during system operation, allow the insertion of a thermal anemometer for the measurement of air velocity. These ports are used to measure the flow of air into each individual VW and should not be adjusted or utilized by unauthorized personnel.

SECTION 3

SYSTEM MAINTENANCE

Although the blower system installed at the POL yard is relatively maintenance free, periodic system maintenance is required to ensure proper operation and long life. Recommended maintenance procedures and schedule are described in detail in the manufacturers' instruction manuals included in Appendix B and briefly summarized in this section.

3.1 Blower/Motor

The blower and motor are relatively maintenance free and should not require any maintenance during the operational period. Both the blower and motor have sealed bearings and do not require lubrication.

3.2 Air Filter

To avoid damage caused by passing solids through the blower, an air filter has been installed in-line before the blower. The paper filter element is accompanied by a polyurethane foam prefilter. The filters should be checked weekly for the first 2 months of operation. Based on the first 2 months of system monitoring, a facility employee should be able to determine the best schedule for filter replacement. The polyurethane prefilters can be washed with lukewarm water and a mild detergent. Paper filter elements should never be washed, and should be disposed of and replaced as necessary. When the pressure or vacuum drop across the filter is 15 inches of water or greater, a dirty filter element should be suspected, and cleaning or replacement should be performed. Typical filter element replacement intervals range from 3 to 6 months.

To remove the filter:

1. Turn the system off by pushing the stop button on the starter,
2. Loosen the three clamps or the wing nut on the filter top,
3. Lift the metal top off the air filter; and
4. Lift the air filter element from the metal housing.

Remove the polyurethane prefilter (if applicable) and wash before replacing. If the paper element is not appreciably clogged, the prefilter may be washed and replaced around the paper element. The entire filter unit is then installed by reversing steps 2

through 4. After the filter has been washed and/or replaced, restart the blower by pressing the start button on the starter box. Do not adjust any of the FCVs during the filter changing procedure; they have been set by Parsons ES personnel to deliver a calculated volume of air to each individual VW. Altering FCV setting may unbalance the system and greatly reduce the effectiveness of the remedial technology.

The filter element is manufactured by Solberg Manufacturing, Inc. in Itasca, Illinois. Their telephone number is (630) 773-1363. The part number for the replacement paper filter element is F-30P-200. Spare air filter elements have been placed inside the blower enclosure.

3.3 Maintenance Schedule

The following maintenance schedule is recommended for the blower systems. During the initial few months of operation, more frequent monitoring is recommended to ensure that any startup problems are quickly corrected. A daily drive-by inspection is recommended during the initial 2 weeks of operation to ensure that the blower system is operating normally. Thereafter, monitoring inspections every 2 weeks are recommended (see Section 4). Preprinted data collection sheets have been provided to facility personnel. Extra data collection sheets for recording maintenance activities are provided in Appendix C.

Maintenance Item	Maintenance Frequency
Filters	Check once every 2 weeks, wash prefilter or replace paper filter as necessary (see Section 3.2). Inlet vacuum exceeding 15 inches of water indicates that the filters require cleaning or replacement.

3.4 Major Repairs

Blower systems are very reliable when properly maintained. Occasionally, however, a motor or blower will develop a serious problem. If a blower system fails to start, and a qualified electrician verifies that power is available at the blower or starter, the base should contact Gast Corporate Headquarters at (616) 926-6171.

SECTION 4

SYSTEM MONITORING

4.1 Blower Performance Monitoring

To monitor the performance of the blower, the inlet vacuum, outlet temperature and outlet pressure should be measured at the blower. These data should be recorded every 2 weeks on a data collection sheet (provided in Appendix C). All measurements should be taken at the same time, while the system is running. Because the blower is noisy, hearing protection should be worn at all times.

4.1.1 Vacuum

With hearing protection in place, unlock and open the blower enclosure and record the vacuum directly from the gauge (in inches of water). Record the measurement on the data collection sheet.

4.1.2 Temperature

With hearing protection in place, unlock and open the blower enclosure and record the temperature directly from the gauge in degrees Fahrenheit (°F). Record the measurement on the data collection sheet (provided in Appendix C). The temperature change can be converted to degrees Celsius (°C) using the formula $^{\circ}\text{C} = (^{\circ}\text{F} - 32) \times 5/9$.

4.1.3 Pressure

With hearing protection in place, unlock and open the blower enclosure and record the main blower pressure (in inches of water) from the pressure gauge located on the blower outlet piping next to the temperature gauge.

4.1.4 Air Flow Rate Measurements

Because of changing site conditions (i.e., depressed groundwater elevations, creation of preferential air flow paths) as the result of continued air injection at the POL yard, it is recommended that periodic air flow rate measurements be conducted by Malmstrom AFB personnel.

Flow rate measurements are collected by inserting the thermal anemometer probe tip into the air velocity measurement port of each VW header pipe at the blower. Prior to

collecting flow measurements, calibration of the anemometer should be conducted by zeroing the meter on the "low range" scale, with the probe tip "cap" in place. Following calibration, remove the "cap" and insert the probe into the air velocity measurement port while ensuring that air does not leak between the probe and measurement port. After probe insertion, press the "read" button until a velocity reading (in feet per minute) registers on the Dwyer anemometer. The actual air flow rate can then be determined by multiplying the air velocity by 0.0127 (for a 1.5-inch-diameter pipe). Generally, air flow rates for each well at the POL yard should range from 3 to 5 acfm. Air flow measurements should be collected for two consecutive days to ensure that system adjustments meet system optimization objectives. Appendix B contains a product data sheet for the Dwyer Thermal Anemometer (Model 470-1), and more detailed operating instructions are contained on the inside cover of the anemometer case.

4.2 Monitoring Schedule

During the initial month of operation, more frequent monitoring is recommended to ensure that any start up problems are quickly corrected. The following monitoring schedule is recommended for this system.

<u>Monitoring Item</u>	<u>Monitoring Frequency</u>
Vacuum/Pressure	Once every 2 weeks.
Temperature	Once every 2 weeks.
Air Flow Rates	Two consecutive days, every 2 months.

APPENDIX A
RECORD DRAWINGS

**RECORD DRAWINGS FOR
EXPANDED BIOVENTING SYSTEM
POL YARD
MALMSTROM AIR FORCE BASE**

PREPARED FOR

AFCEE

JANUARY 1997

DRAWING INDEX

DRAWING NO

G-0.1	TITLE SHEET AND SITE LAYOUT
G-0.2	LEGEND AND STANDARD TRENCH DETAILS
G-0.3	VENT WELL AND MONITORING POINT STANDARD DETAILS
G-0.4	BLOWER P & ID
G-0.5	BLOWER PIPING LAYOUT DETAIL
G-0.6	BLOWER SHED FIELD INSTALLATION DETAIL AND BLOWER SHED CONSTRUCTION DETAILS

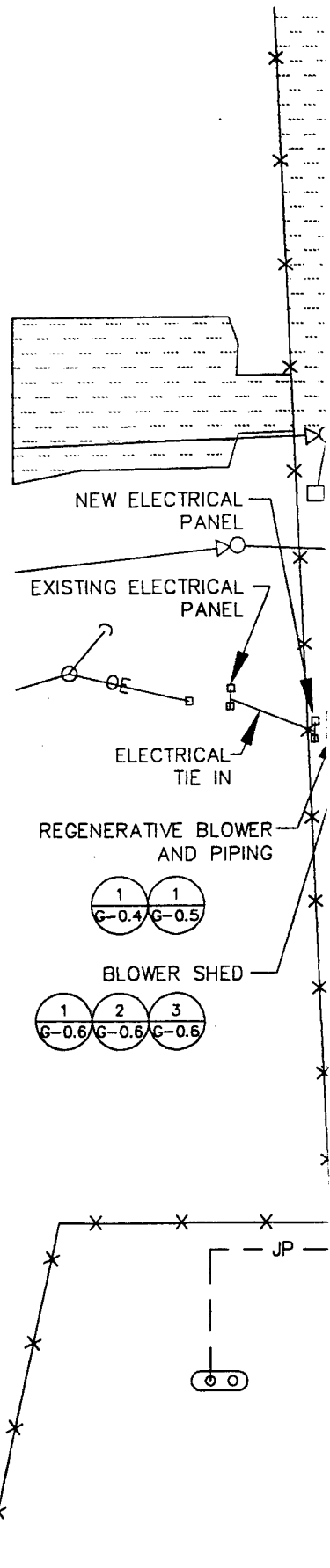

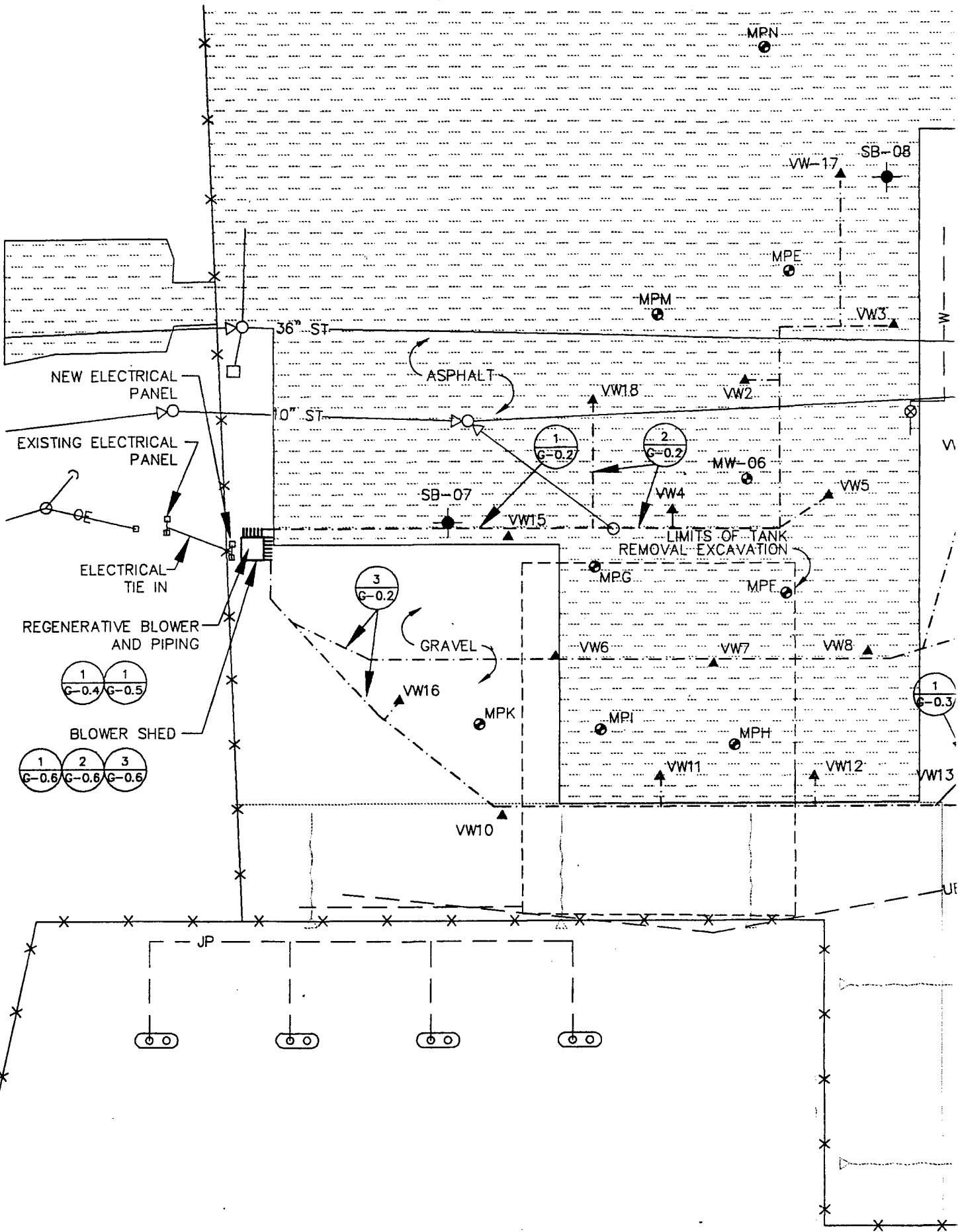

SITE LAYOUT

SCALE: 1"=50'

ABBREVIATIONS

AJ	AIR INJECTION
APPROX	APPROXIMATE
ASTM	AMERICAN SOCIETY OF TESTING AND MATERIALS
&	AND
⊙	AT
CBM	CENTER BACK MOUNT
CFM	CUBIC FEET PER MINUTE
CLR	CLEAR
DIA	DIAMETER
DWG	DRAWING
EB	EXPLORATORY BORING
ECC	ECCENTRIC
EW	EACH WAY
FOT	FLAT ON TOP
FPT	FEMALE PIPE THREAD
FT	FOOT
GALV	GALVANIZED STEEL
HDPE	HIGH DENSITY POLYETHYLENE
ie	FOR EXAMPLE
JP	JET PROPULSION FUEL
LM	LOWER MOUNT
MAX	MAXIMUM
MIN	MINIMUM
MP	MONITORING POINT
MPT	MALE PIPE THREAD
NO, #	NUMBER
NPT	NATIONAL PIPE THREAD
NTS	NOT TO SCALE
OC	ON CENTER
OD	OUTSIDE DIAMETER
OE	OVERHEAD ELECTRIC
POL	PETROLEUM, OIL & LUBRICANT
PVC	POLYVINYL CHLORIDE
PW	PROPOSED WELL
RED	REDUCER
REF	REFERENCE
SCH	SCHEDULE
S	SOCKET
SB	SOIL BORING
SPVC	SLOTTED POLYVINYL CHLORIDE
ST	STORM SEWER
ST STL	STAINLESS STEEL
TYP	TYPICAL
UE	UNDERGROUND ELECTRIC
UST	UNDERGROUND STORAGE TANK
VW	VENT WELL
W	WATER
W/	WITH
WN	WELD NECK
WWF	WELDED WIRE FABRIC

SYMBOLS

MW-12 ⊙	GROUNDWATER MONITORING WELL
MPA ⊕	BIOVENTING MONITORING POINT
VW1 ▲	VENT WELL
SB-07 ⊙	PREVIOUS SOIL BORING
---	SLOPE
- - - - -	HEADER PIPE TO VENT WELL
- x - x -	FENCE

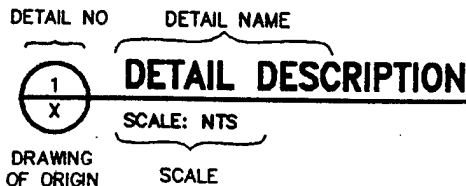
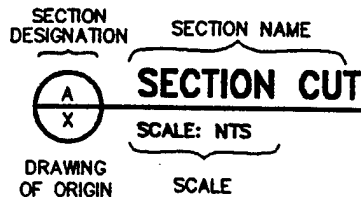

MATERIAL LEGEND

	ASPHALT
	BENTONITE
	BENTONITE/CEMENT GROUT
	BENTONITE PELLETS
	BUILDING (EXISTING)
	COMPACTED BACKFILL
	COMPACTED BASE STONE
	CONCRETE
	PEA GRAVEL
	SAND
	UNDISTURBED SOIL

PIPE MATERIAL

CS	CARBON STEEL
GALV	GALVANIZED STEEL
PVC	POLYVINYL CHLORIDE
SPVC	SCREENED POLYVINYL CHLORIDE

PIPE SERVICE

AJ	AIR INJECTION
BIV	BIOVENTING
DR	DRAIN



SAWCUT E
BOND NE'

EXISTING

1 1/2'
PI

1 1/2'
F











SECTION NAME
SECTION CUT

SCALE: NTS

DETAIL NAME
DETAIL DESCRIPTION

SCALE: NTS

LEGEND

-  ASPHALT
-  BENTONITE
-  BENTONITE/CEMENT GROUT
-  BENTONITE PELLETS
-  BUILDING (EXISTING)
-  COMPACTED BACKFILL
-  COMPACTED BASE STONE
-  CONCRETE
-  PEA GRAVEL
-  SAND
-  UNDISTURBED SOIL

- MATERIAL**
- STEEL
 - ZINC COATED STEEL
 - PVC
 - POLYETHYLENE GLYCOL
 - POLYETHYLENE TEREPHTHALATE
 - POLYPROPYLENE
 - POLYURETHANE
 - POLYVINYL CHLORIDE

SERVICE

SECTION
 NUMBER

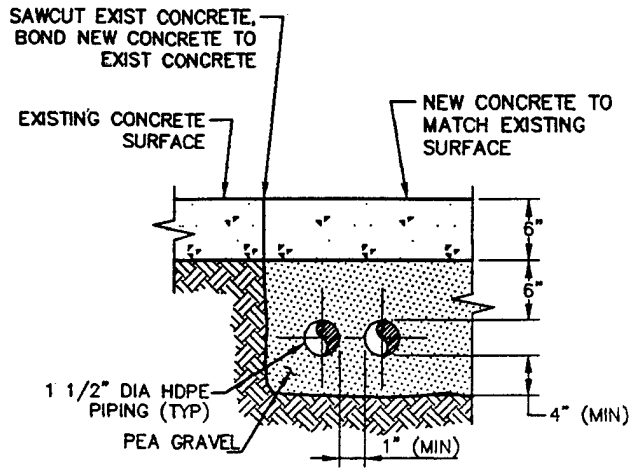

CONCRETE REPLACEMENT DETAIL
 SCALE: NTS

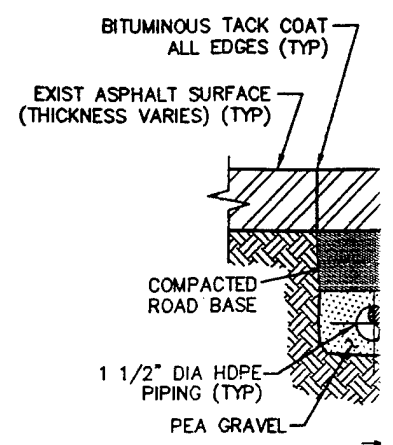

ASPHALT REPLACEMENT DETAIL
 SCALE: NTS

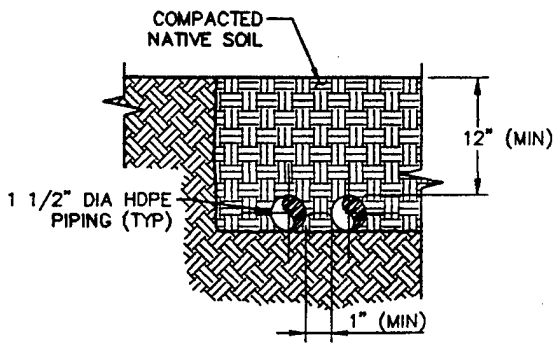

SOIL COVER REPLACEMENT DETAIL
 SCALE: NTS

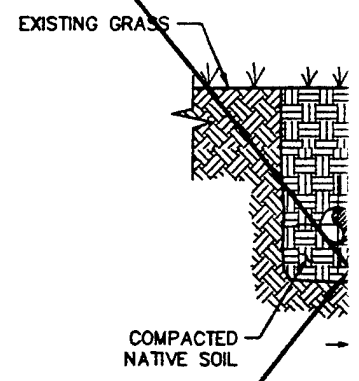

GRASS REPLACEMENT DETAIL
 SCALE: NTS

CONCRETE TO EXISTING CE

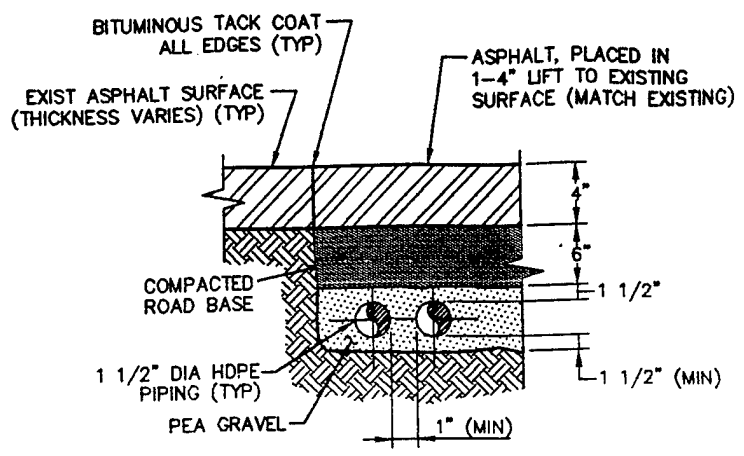
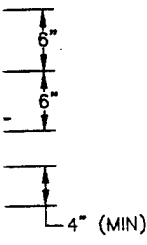

DETAIL

ASPHALT REPLACEMENT DETAIL
 2
 SCALE: NTS

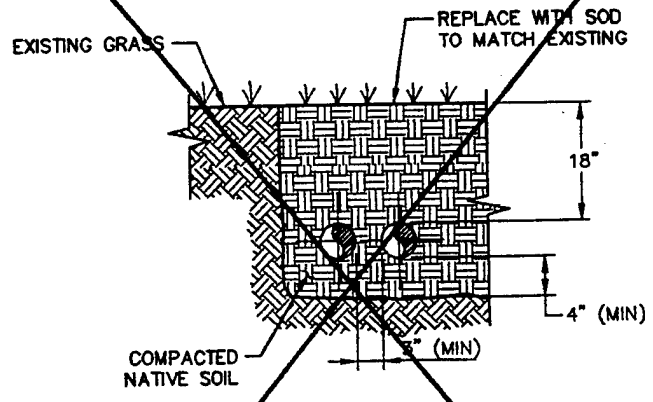
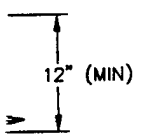

DETAIL

GRASS COVER REPLACEMENT DETAIL
 3
 SCALE: NTS

Job No. 726876.361.30	Designed DBT	Drawn MW	Checked	Reviewed	Approved DT	Reg No	Date	Rev	Date	Description	By
							1/20/97	1	1/13/97	RECORD DRAWINGS	

PARSONS ENGINEERING SCIENCE, INC.
 (303) 631-8100
 Denver, Colorado

AIR FORCE CENTER FOR ENVIRONMENTAL EXCELLENCE (AFCEE)
 EXPANDED BIOVENTING SYSTEM
 POL YARD
 MALMSTROM AIR FORCE BASE

LEGEND AND STANDARD TRENCH DETAILS

DRAWING NO	REV
G-0.2	1

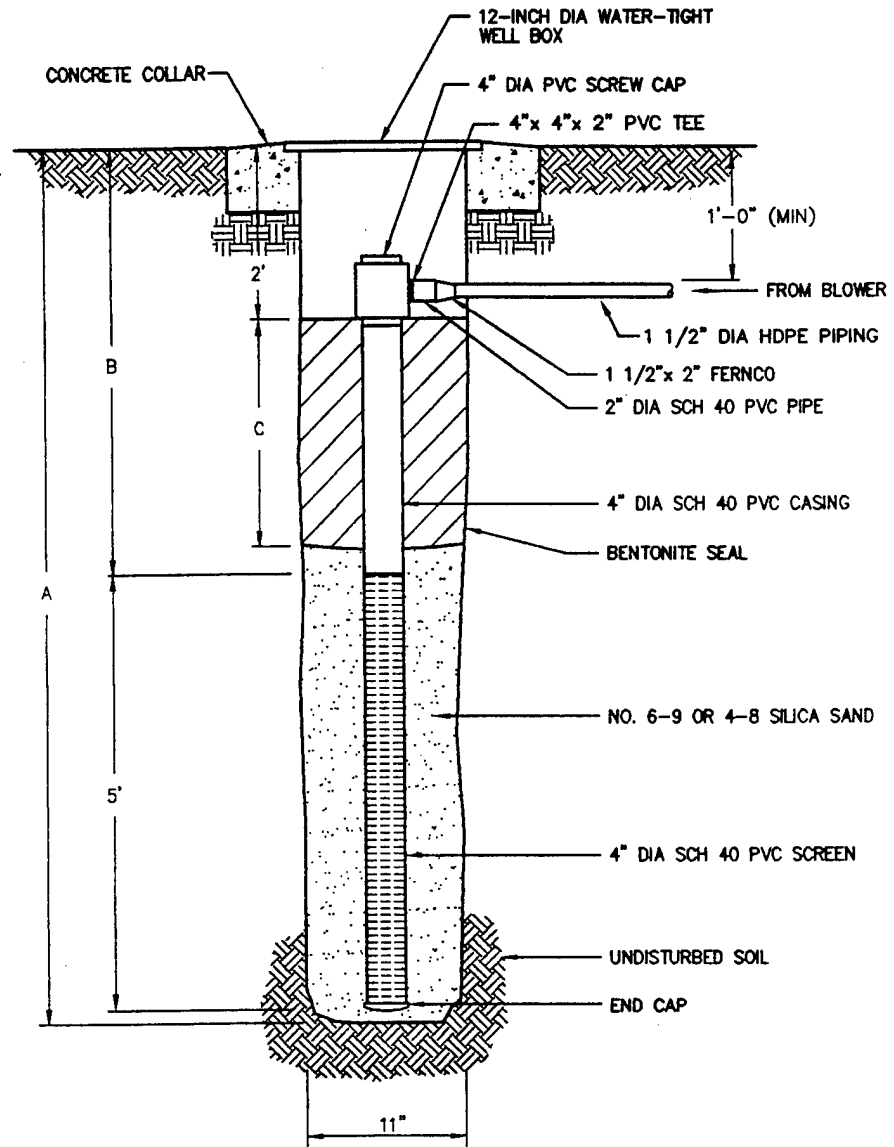

WELL	WELL DIMENSIONS (feet)			SCREEN SLOT (inches)
	A	B	C	
VW1	10.5	5	2.2	0.04
VW2	10	4.5	2	0.04
VW3	10	4.5	2.1	0.04
VW4	10	4.5	2	0.04
VW5	10	4.5	2	0.04
VW6	9.5	4	2	0.04
VW7	10	4.5	2	0.04
VW8	10	4.5	2	0.04
VW9	10	4.5	2	0.04
VW10	10	4.5	2	0.02
VW11	10	4.5	2	0.04
VW12	10	4.5	2	0.04
VW13	10	4.5	1.9	0.04
VW14	10	4.5	2	0.04
VW15	10	4.5	2	0.02
VW16	10	4.5	2	0.02
VW17	10	4.5	2	0.02
VW18	10	4.5	2	0.02

1
-

VENT WELL (VW) DETAIL

SCALE: NTS

1

- WATER-TIGHT
- REW CAP
- 1" PVC TEE
- 1'-0" (MIN)
- FROM BLOWER
- 1 1/2" DIA HDPE PIPING
- 1/2" x 2" FERRO
- 1" DIA SCH 40 PVC PIPE
- 1" DIA SCH 40 PVC CASING
- BENTONITE SEAL
- 6-9 OR 4-8 SILICA SAND
- 1" DIA SCH 40 PVC SCREEN
- UNDISTURBED SOIL
- 10" DIA CAP

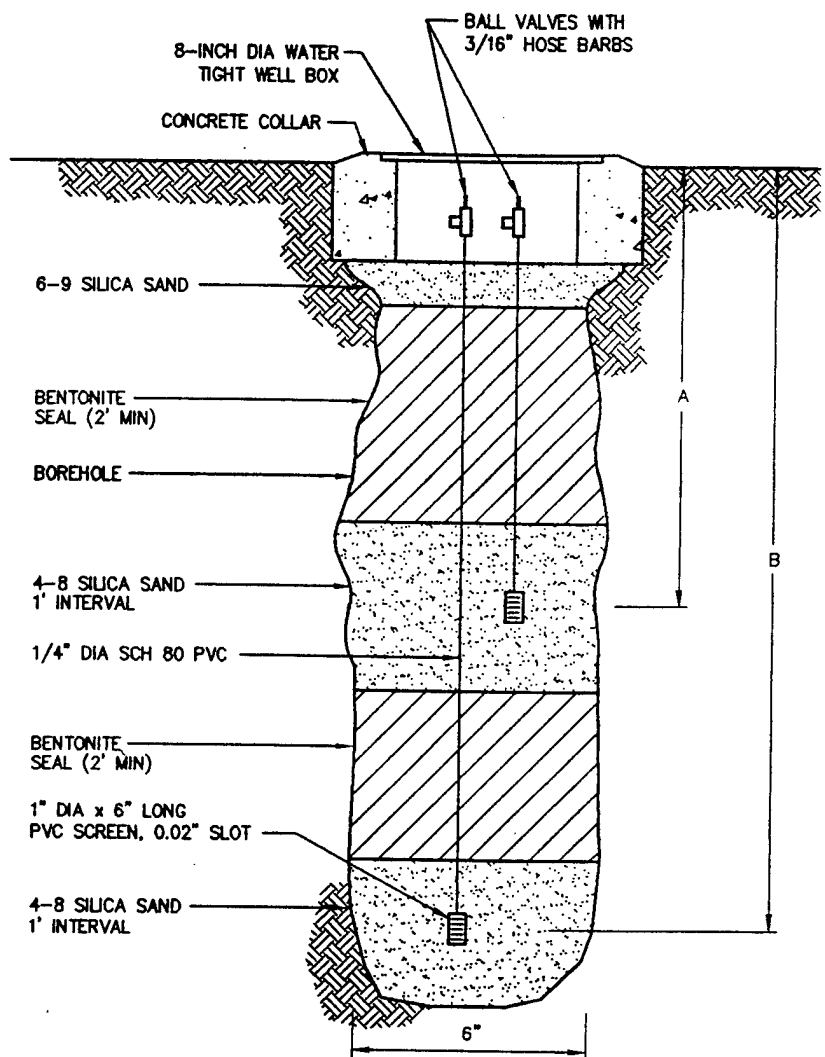

MONITORING POINT	DEPTH TO SCREENED INTERVALS (ft bgs) ^{a/}	
	A	B
MPA	3.5	7.5
MPB	3.5	7.5
MPC	3.5	7.5
MPD	4.5	-b/
MPE	4.5	-
MPF	4.5	8.0
MPG	3.5	5.5
MPH	3.5	-
MPI	3.5	-
MPJ	4.0	-
MPK	4.5	-
MPL	3.0	-
MPM	4.5	-
MPN	5.5	-

^{a/}ft bgs = FEET BELOW GROUND SURFACE
^{b/} - = NO DEEP MP INSTALLED

2 MONITORING POINT (MP) DETAIL
 SCALE: NTS

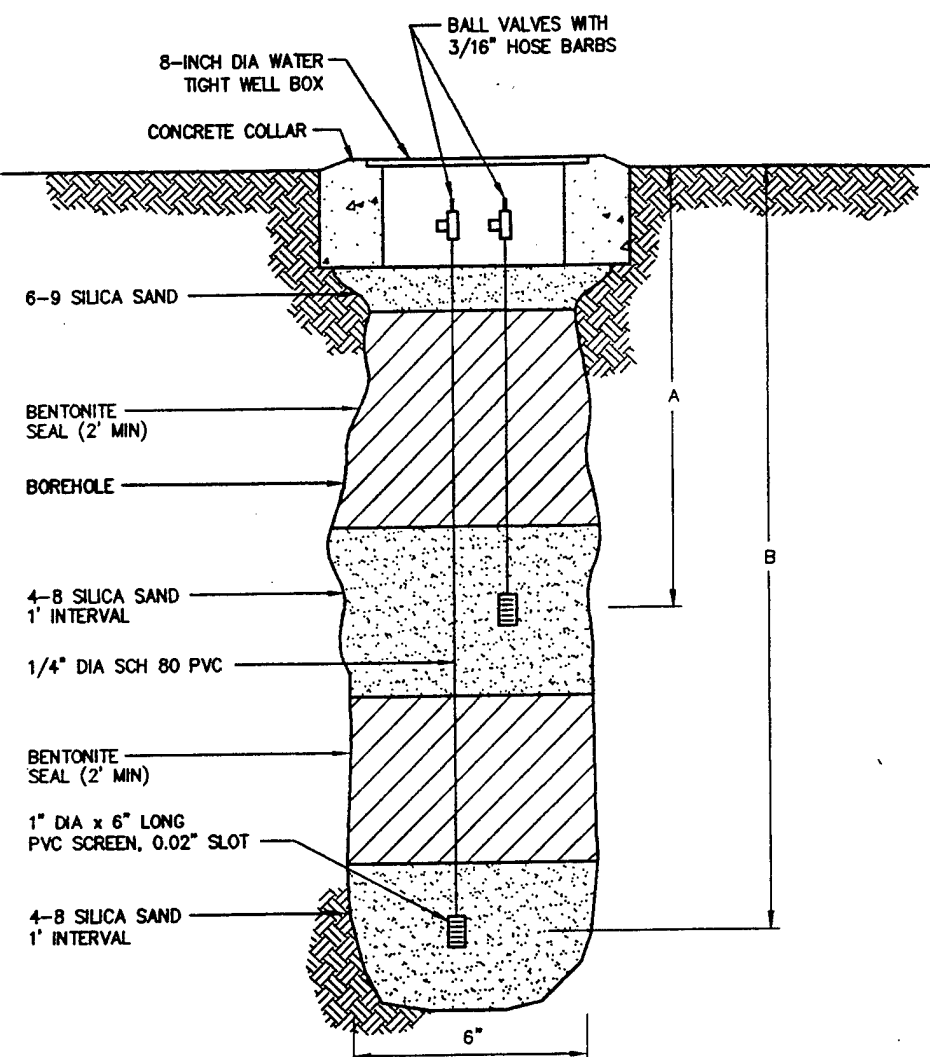

MONITORING POINT	DEPTH TO SCREENED INTERVALS (ft bgs) ^{a/}	
	A	B
MPA	3.5	7.5
MPB	3.5	7.5
MPC	3.5	7.5
MPD	4.5	-b/
MPE	4.5	-
MPF	4.5	8.0
MPG	3.5	5.5
MPH	3.5	-
MPI	3.5	-
MPJ	4.0	-
MPK	4.5	-
MPL	3.0	-
MPM	4.5	-
MPN	5.5	-

a/ft bgs = FEET BELOW GROUND SURFACE
b/ - = NO DEEP MP INSTALLED

2 MONITORING POINT (MP) DETAIL
SCALE: NTS

3

Job No. 728876.38130	Designed DBT	Drawn MW	Checked	Reviewed DT	Approved	Reg No	Date	Rev	Date	Description
							1/22/97	1	1/22/97	RECORD DRAWINGS
PARSONS ENGINEERING SCIENCE, INC. (303) 831-8100 Denver, Colorado										
AIR FORCE CENTER FOR ENVIRONMENTAL EXCELLENCE (AFCEE) EXPANDED BIOVENTING SYSTEM POL SITE MALMSTROM AIR FORCE BASE										
VENT WELL AND MONITORING POINT STANDARD DETAILS										
DRAWING NO						REV				
G-0.3						1				

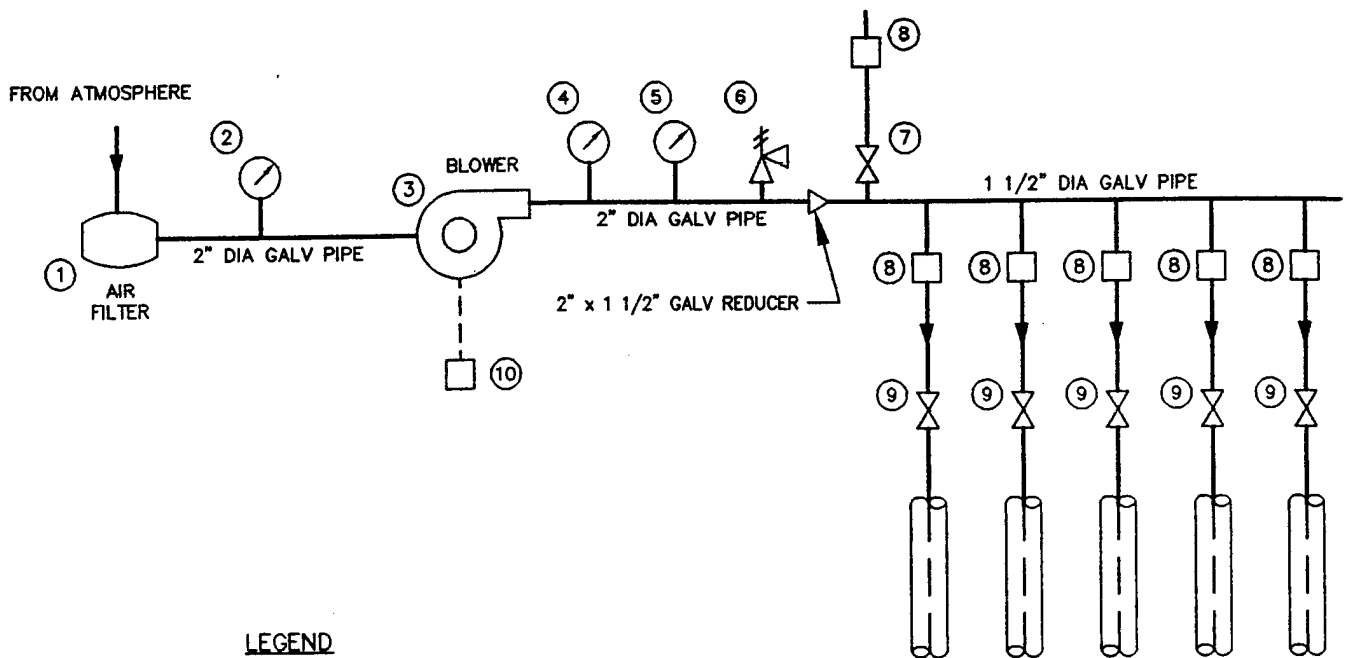

LEGEND

- ① INLET AIR FILTER - SOLBERG F-30P-150, REPLACEMENT ELEMENT 30P
- ② VACUUM GAUGE - GAST® AJ497, 2 1/2" DIA, 0-60" H₂O, 1/4" NPT, LM
- ③ BLOWER - GAST® 6.0HP R6P355R-50, 215 CFM AT 50" H₂O PRESSURE
- ④ TEMPERATURE GAUGE - ASHCROFT, 0-250°F, 1/2" NPT, CBM (Part No. 2A606 FROM GRAINGER)
- ⑤ PRESSURE GAUGE - WIKA 611.10, 2 1/2" DIA., 0-200" H₂O, 1/4" NPT, LM (Part No. 9851828)
- ⑥ AUTOMATIC PRESSURE RELIEF VALVE - GAST® AG258, SET TO RELEASE AT 120" H₂O PRESSURE
- ⑦ MANUAL PRESSURE RELIEF (BLEED) VALVE - 1 1/2" GATE
- ⑧ FLOW MEASURING PORT FITTED WITH PLUG (1/4" x 1/8" NPT BRASS REDUCING BUSHING, 1/8" NPT BRASS PLUG)
- ⑨ FLOW CONTROL VALVE - 1 1/2" GATE
- ⑩ DISCONNECT SWITCH

8
7

1 1/2" DIA GALV PIPE

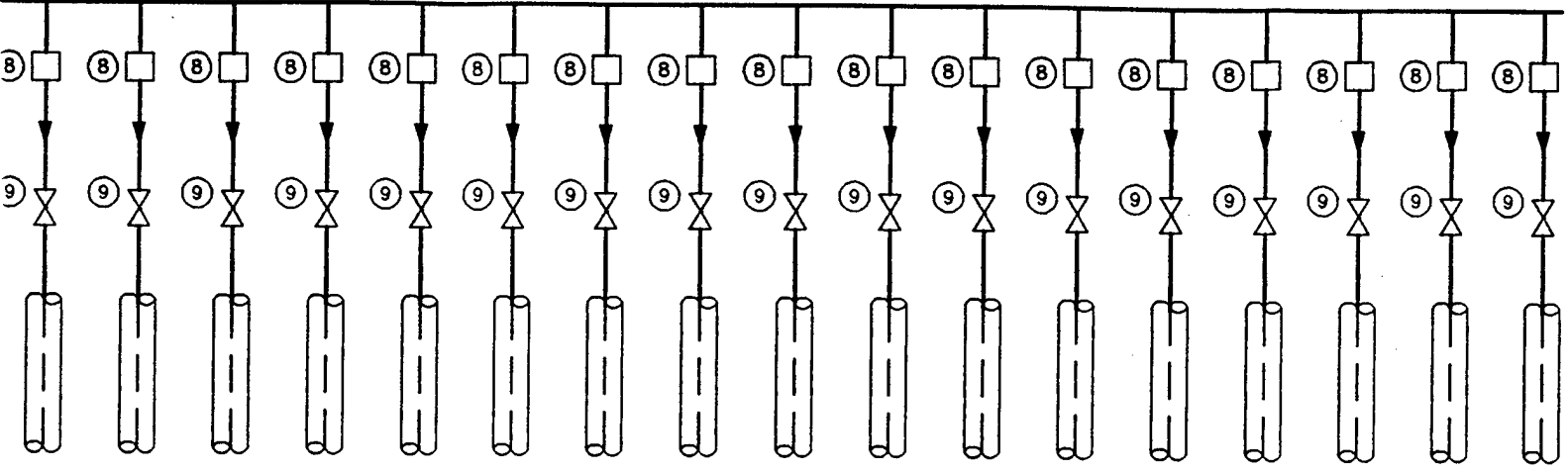

1) PRESSURE

(ING, 1/8" NPT BRASS PLUG)

BLOWER PIPING AND INSTRUMENTATION DIAGRAM

SCALE: NTS

TION DIAGRAM

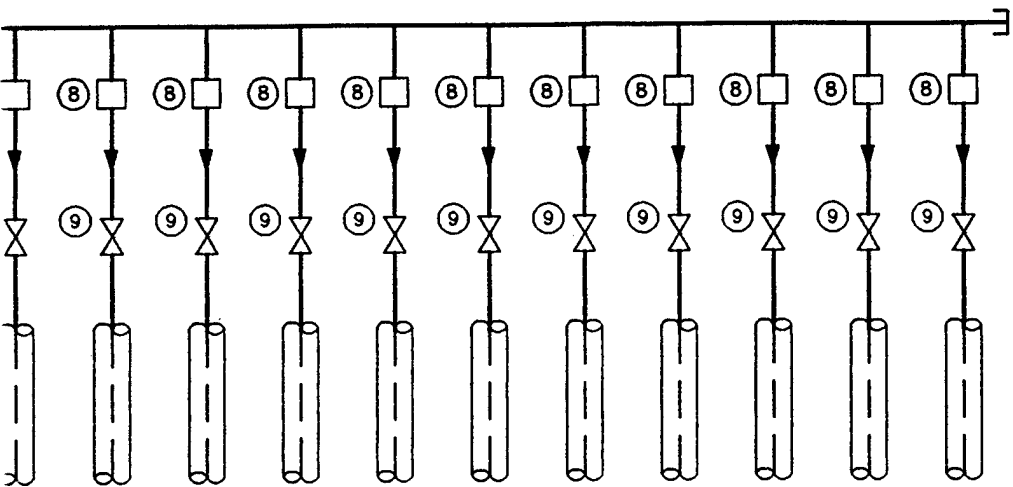

3

PARSONS ENGINEERING SCIENCE, INC. Denver, Colorado (303) 831-8100		Job No. 728876.38130	
		Designed DBT	Drawn MW
AIR FORCE CENTER FOR ENVIRONMENTAL EXCELLENCE (AFCEE) EXPANDED BIOVENTING SYSTEM POL YARD MALLSTROM AIR FORCE BASE		Checked	Reviewed
		Approved	Date
BLOWER P & ID		Reg No 1	Date 1/13/97
		Description RECORD DRAWINGS	By
DRAWING NO G-0.4	REV 1		

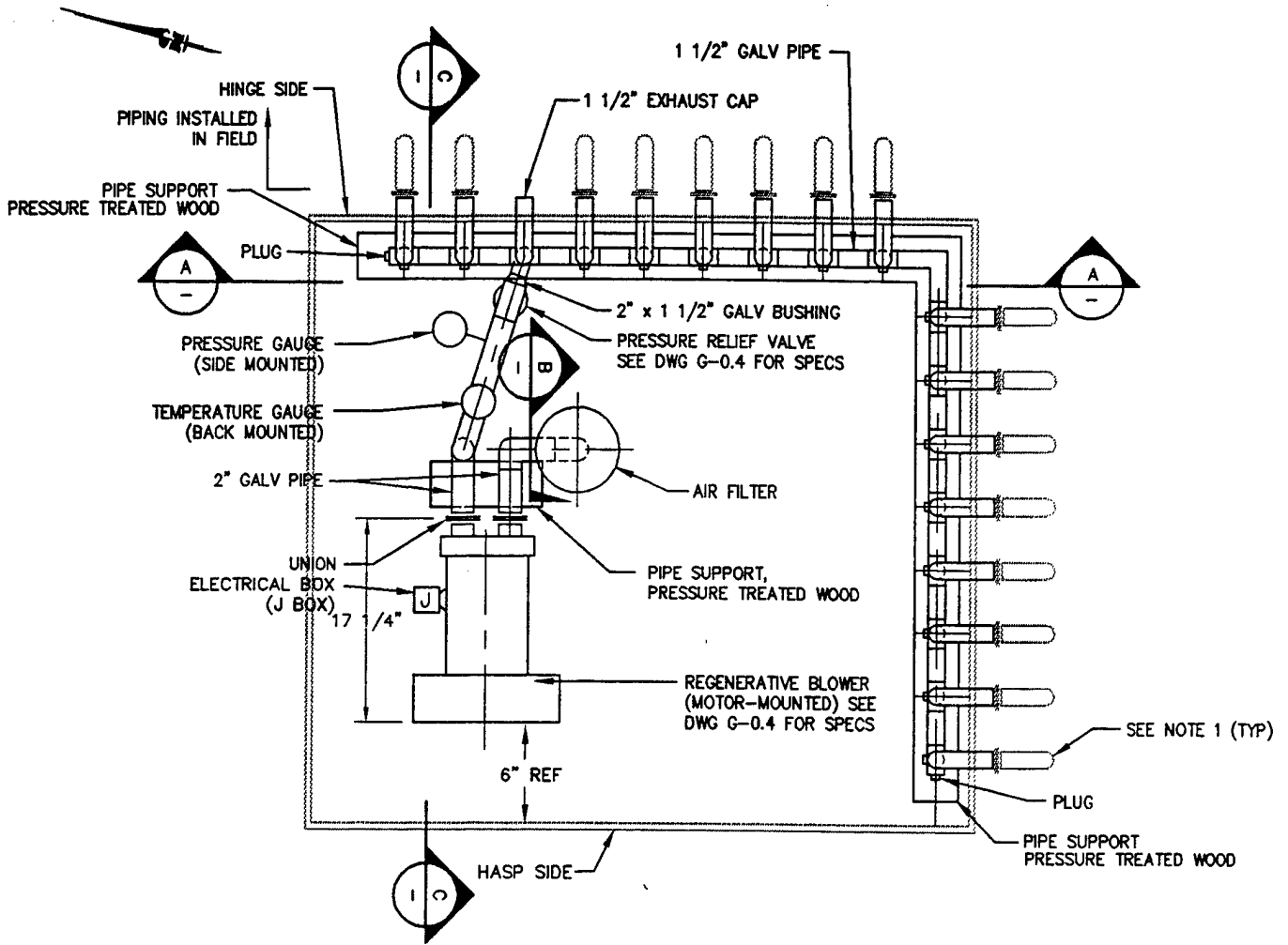

1
-
BLOWER PIPING LAYOUT PLAN DETAIL
3/4" = 1'-0"

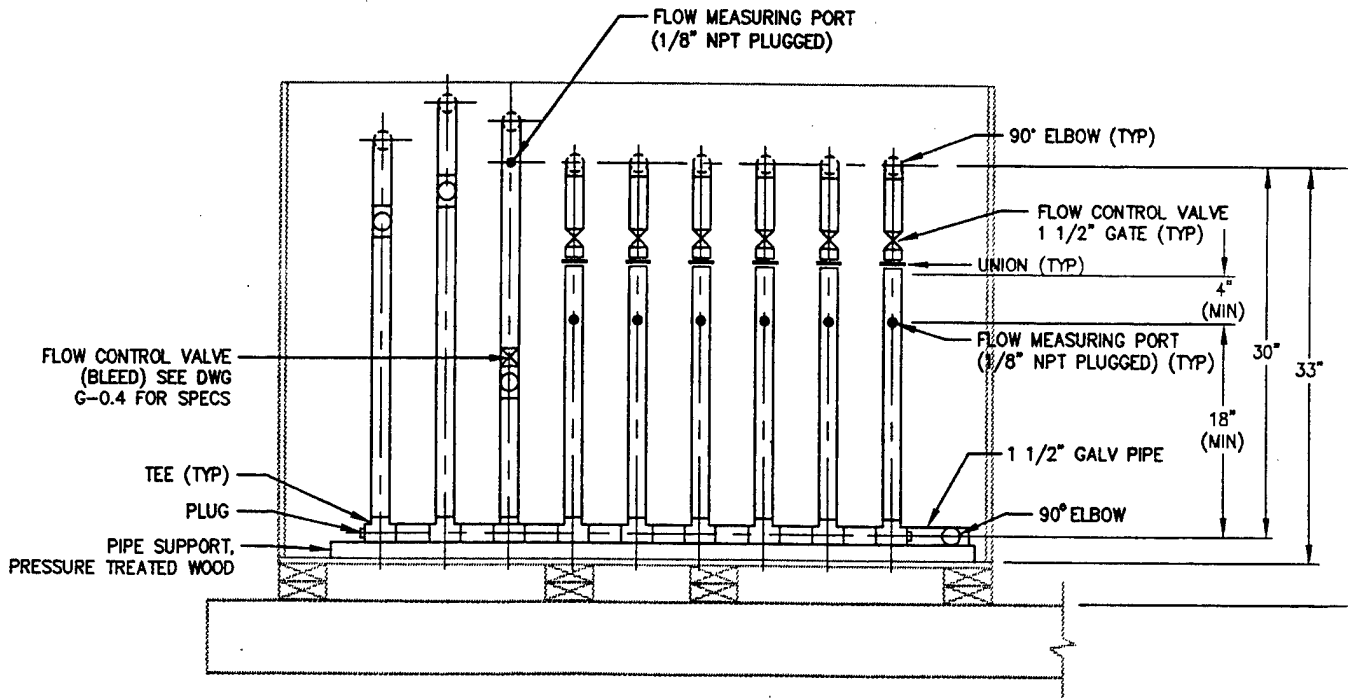

A
-
MANIFOLD DETAIL SECTION
3/4" = 1'-0"

NOTES:

1. ALL PIPING 1 1/2" DIA. GALVANIZED STEEL, UNLESS OTHERWISE NOTED
2. SEE DRAWING G-0.6 FOR BLOWER BUILDING DETAILS

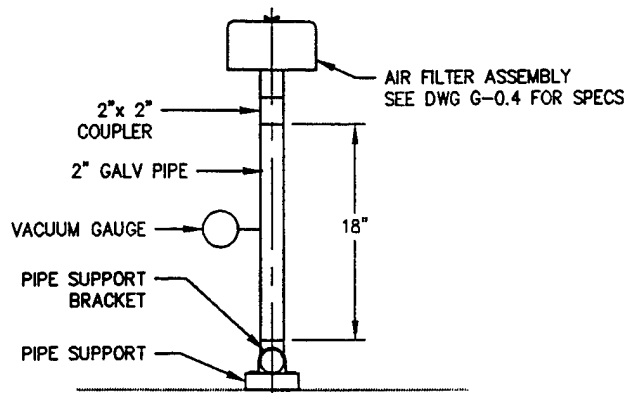
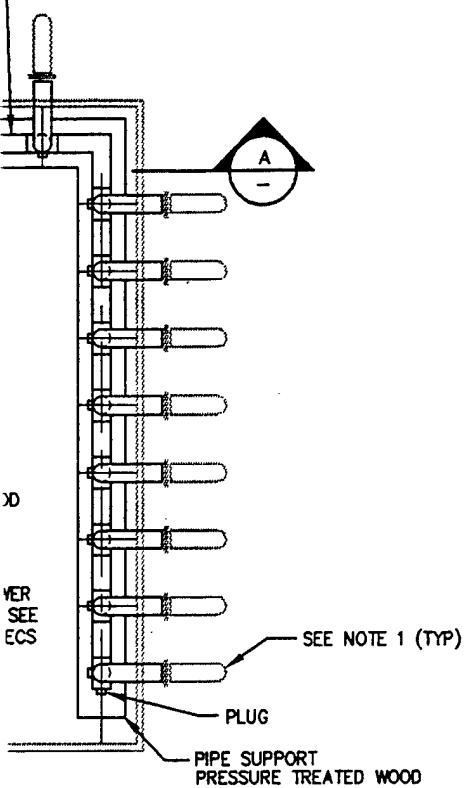

BLOWER INLET PIPING SECTION
3/4" = 1'-0"

AN DETAIL

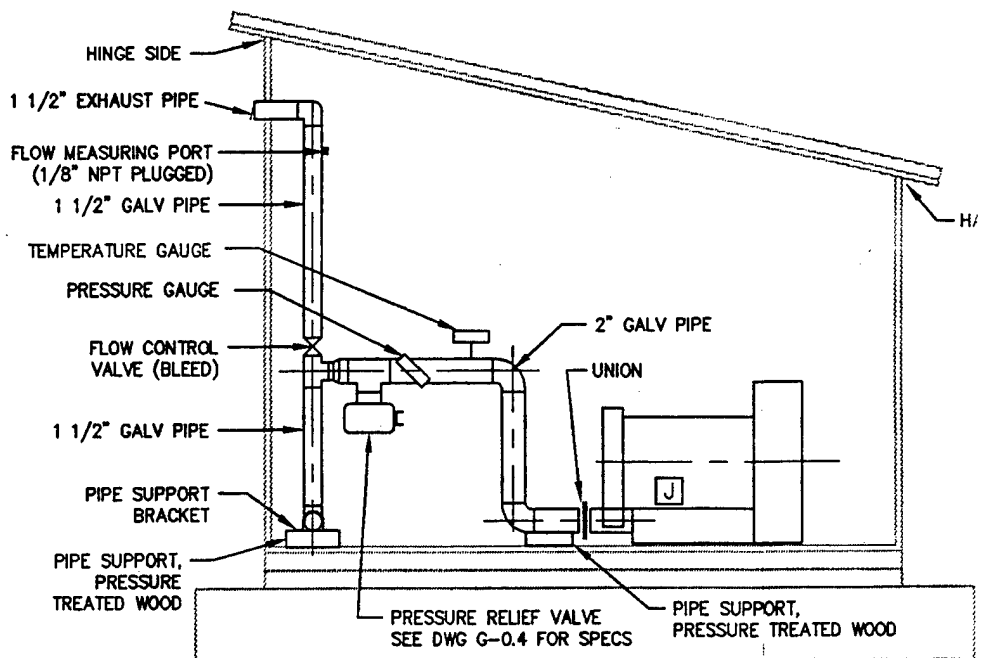
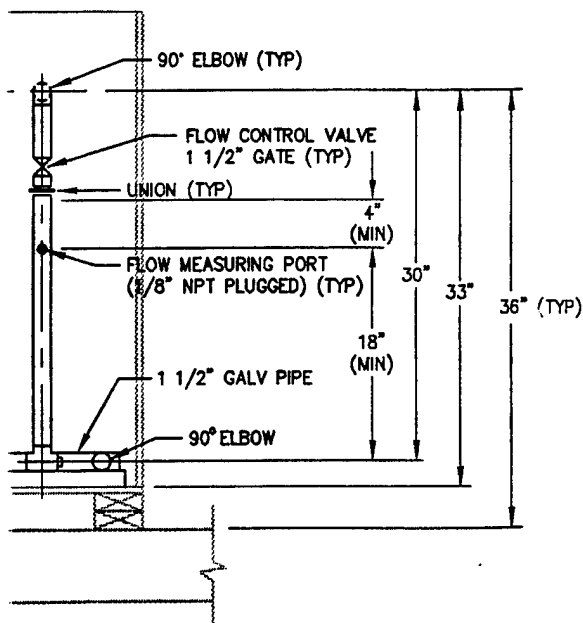

BLOWER OUTLET PIPING SECTION
3/4" = 1'-0"

NOTES:

1. ALL PIPING 1 1/2" DIA. GALVANIZED STEEL, UNLESS OTHERWISE NOTED
2. SEE DRAWING G-0.6 FOR BLOWER BUILDING DETAILS

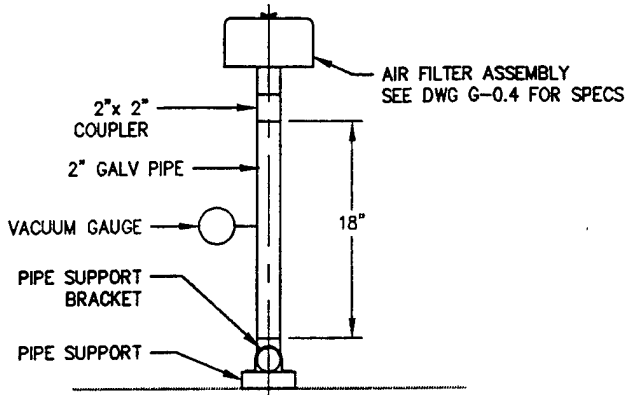

B **BLOWER INLET PIPING SECTION**
3/4" = 1'-0"

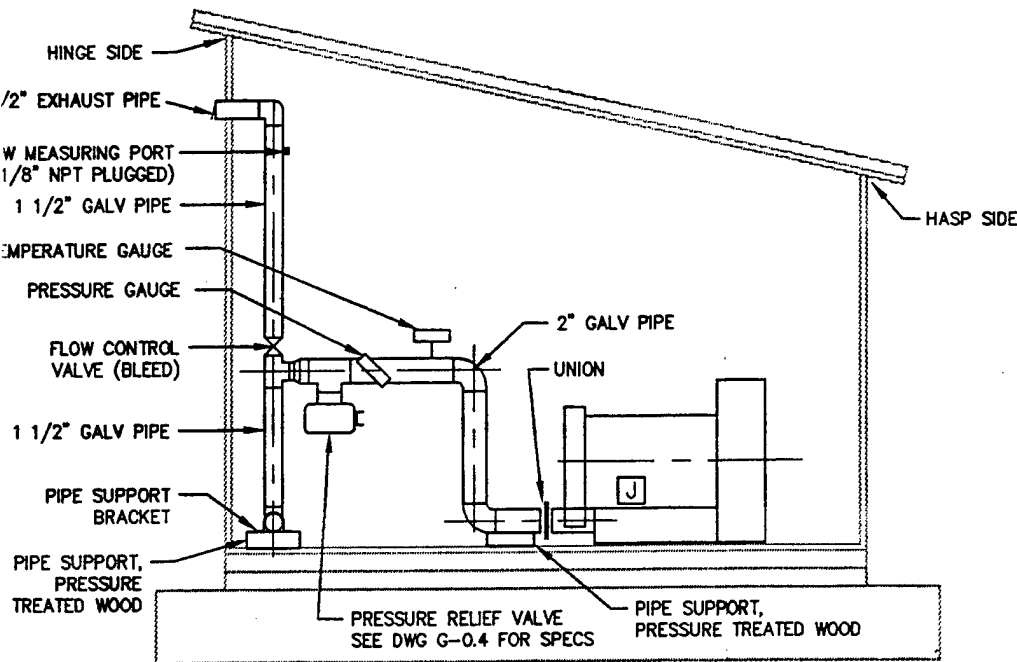

C **BLOWER OUTLET PIPING SECTION**
3/4" = 1'-0"

9

Job No. 726876.38130		By
Designed DBT	11/30/97	RECORD DRAWINGS
Drawn MW	12/13/96	Description
Checked		
Reviewed		
Approved DT		
Reg No	1	
Date		
PARSONS ENGINEERING SCIENCE, INC. Denver, Colorado (303) 831-8100		
AIR FORCE CENTER FOR ENVIRONMENTAL EXCELLENCE (AFCEE) EXPANDED BIOVENTING SYSTEM MALMSTROM AIR FORCE BASE		
BLOWER PIPING LAYOUT DETAIL		
DRAWING NO	REV	
G-0.5	1	

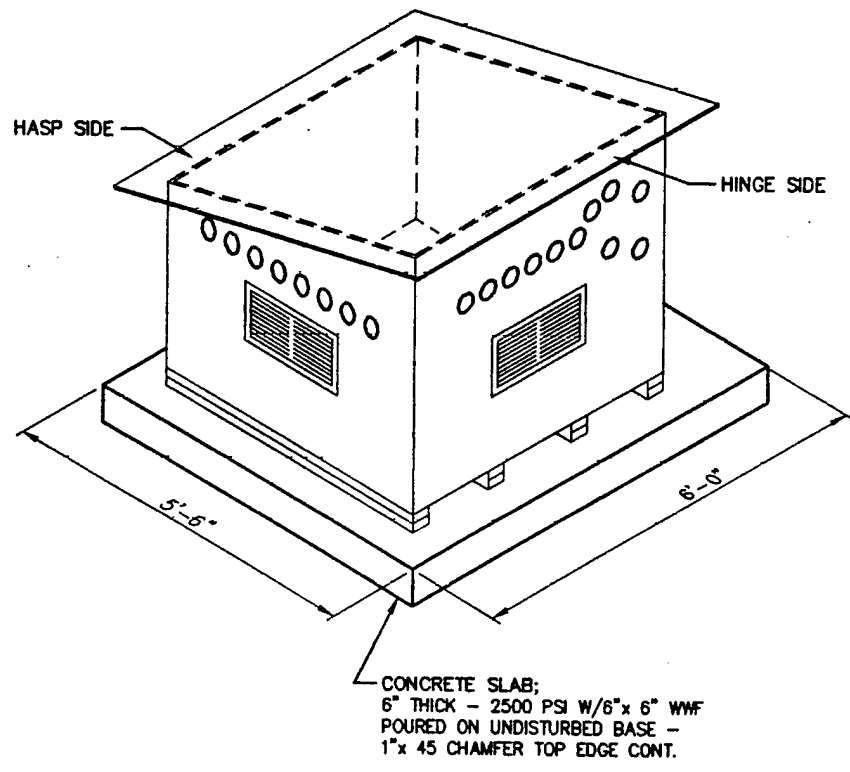

BLOWER SHED FIELD INSTALLATION DETAIL

NOT TO SCALE

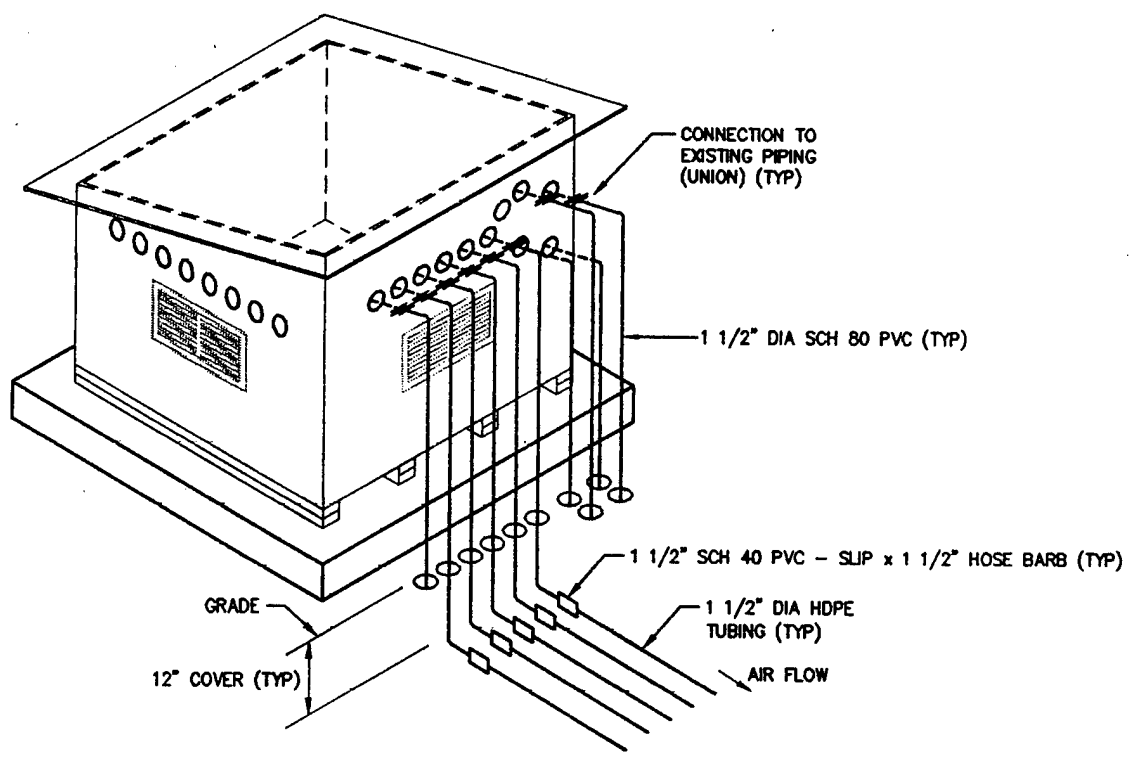

TYPICAL MANIFOLD DISCHARGE PIPING LAYOUT

NOT TO SCALE



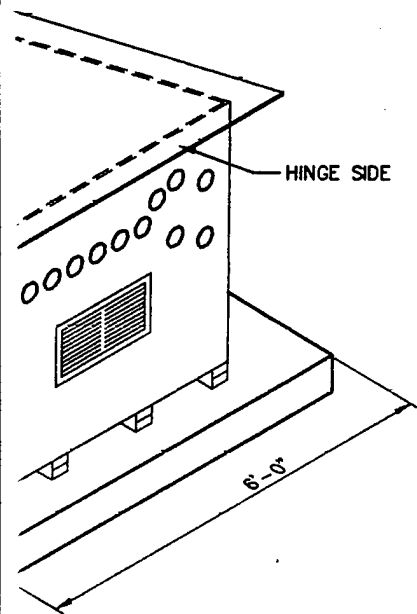

TE SLAB;
 - 2500 PSI W/6"x 6" WWF
 ON UNDISTURBED BASE -
 HAMFER TOP EDGE CONT.

INSTALLATION DETAIL

ALE

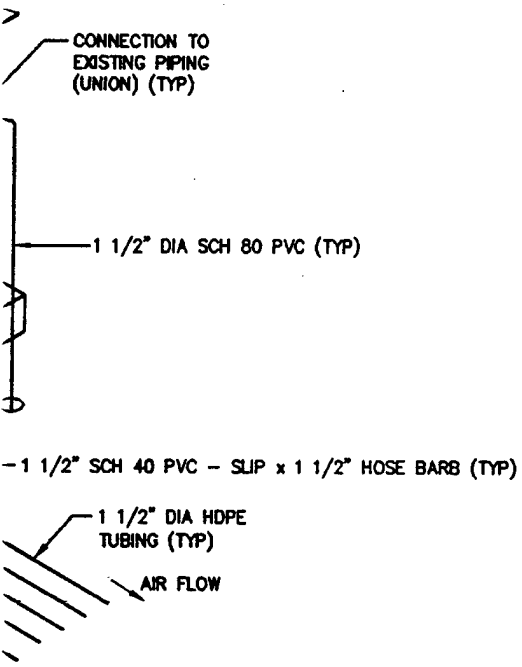

LARGE PIPING LAYOUT

LE

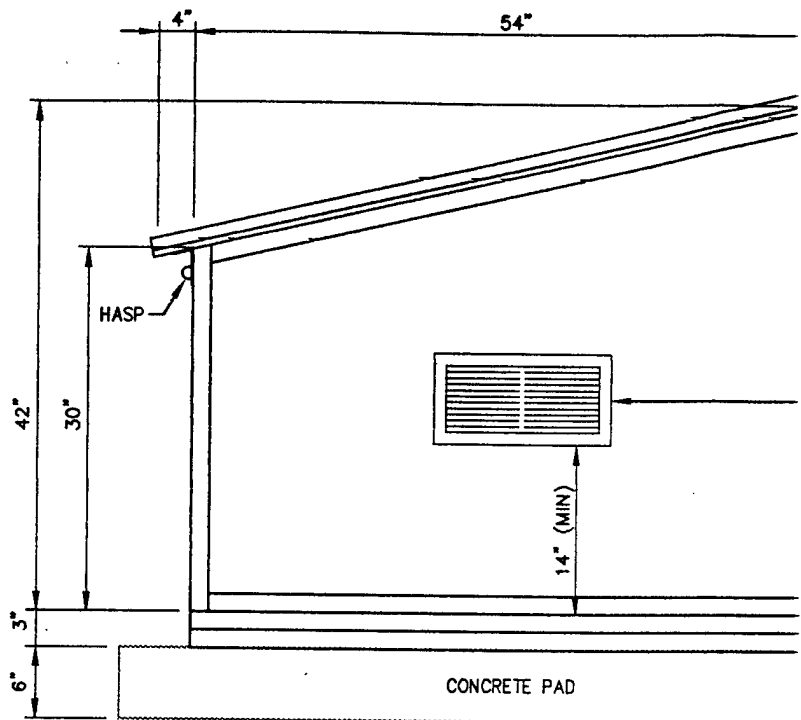

SIDE ELEVATION

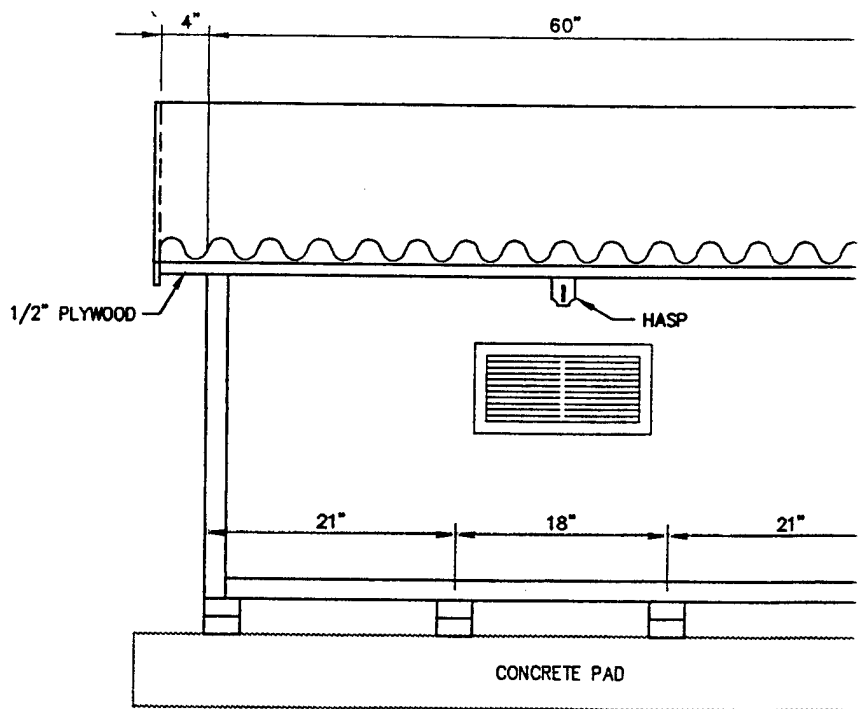

FRONT ELEVATION

- NOTES:
1. 2"x 2" FRAME CONSTRUCTION
 2. FLOOR CONSTRUCTED OF 3/4" EXTERIOR GRADE PLYWOOD
 3. ROOF CONSTRUCTED OF 1/2" EXTERIOR GRADE PLYWOOD COVERED WITH PVC VINYL CORRUGATED ROOFING

BLOWER SHED CONSTRUCTION DE

3/4" = 1'-0"

2

3

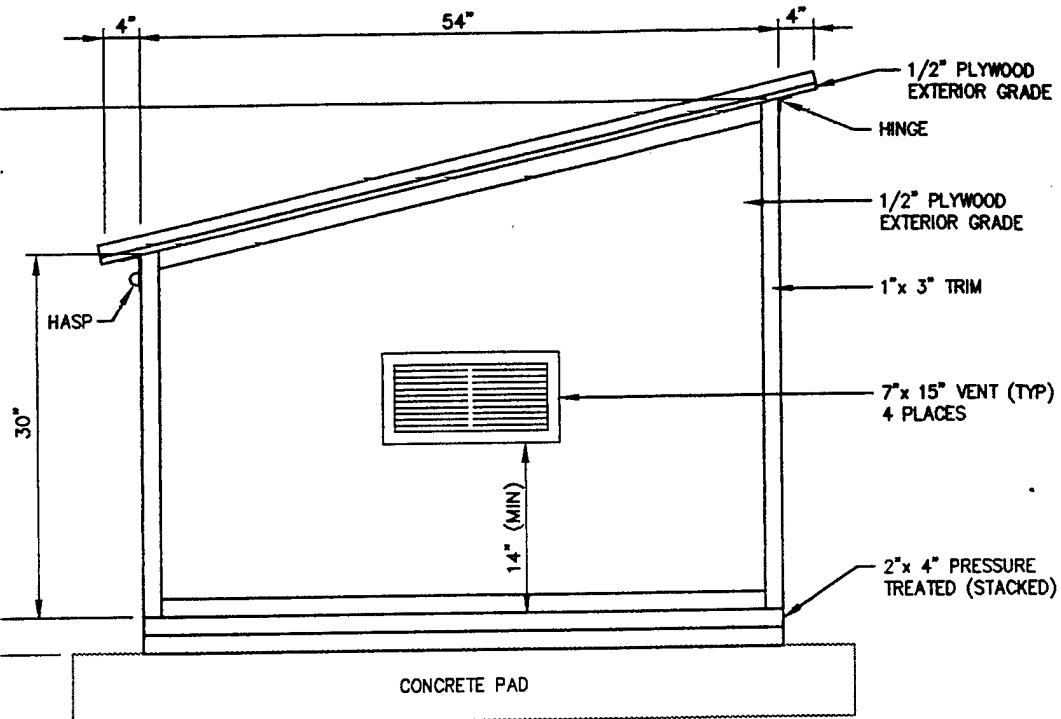

SIDE ELEVATION

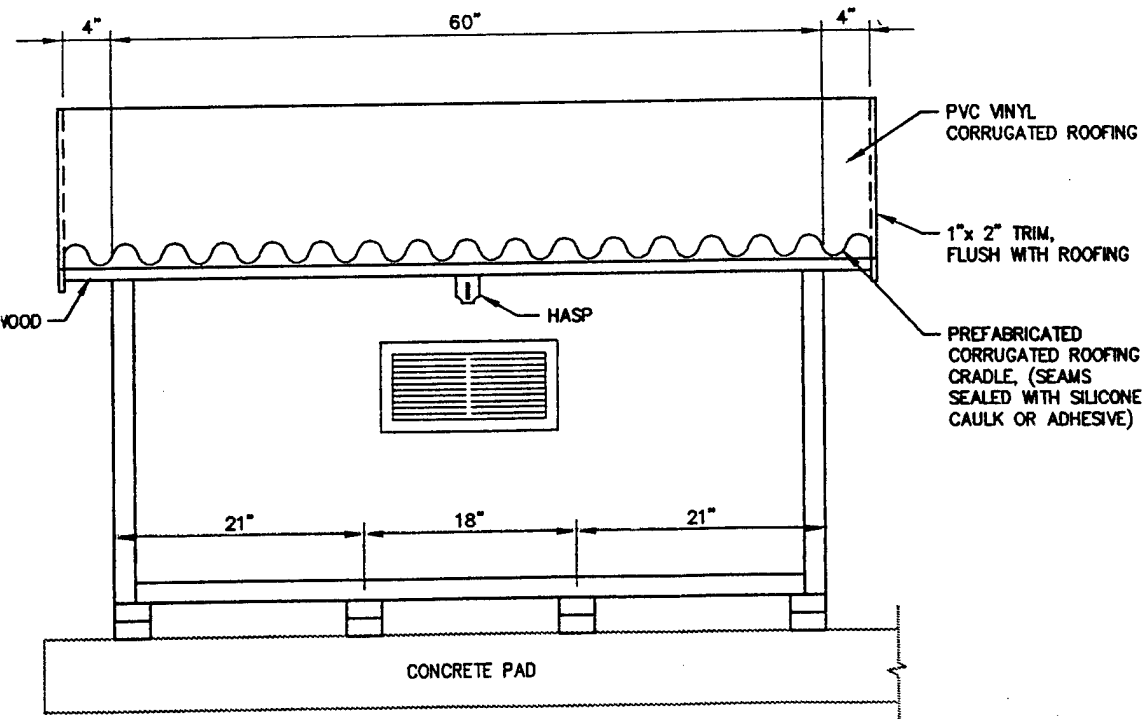

FRONT ELEVATION

NOTES:

1. 2" x 2" FRAME CONSTRUCTION
2. FLOOR CONSTRUCTED OF 3/4" EXTERIOR GRADE PLYWOOD
3. ROOF CONSTRUCTED OF 1/2" EXTERIOR GRADE PLYWOOD COVERED WITH PVC VINYL CORRUGATED ROOFING

BLOWER SHED CONSTRUCTION DETAIL

3/4" = 1'-0"

Job No. 726876.36130	Designed DBT	Drawn MW	Checked	Reviewed	Approved	Reg No	Date	Rev	Date	Description
							1/30/97	1	1/13/97	RECORD DRAWINGS

PARSONS ENGINEERING SCIENCE, INC.
 Denver, Colorado
 (303) 831-8100

AIR FORCE CENTER FOR ENVIRONMENTAL EXCELLENCE (AFCEE)
 EXPANDED BIOVENTING SYSTEM
 POL YARD
 MALLMSTROM AIR FORCE BASE

BLOWER SHED FIELD INSTALLATION DETAIL AND BLOWER SHED CONSTRUCTION DETAILS

DRAWING NO	REV
G-0.6	1

3

3

APPENDIX B
REGENERATIVE BLOWER INFORMATION



Post Office Box 97
Benton Harbor, Michigan 49023-0097
Ph: 616/926-6171
Fax: 616/925-8288

Maintenance Instructions for Gast Standard Regenerative Blowers

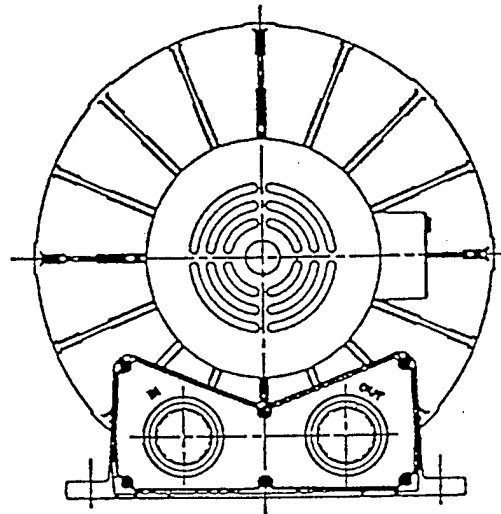
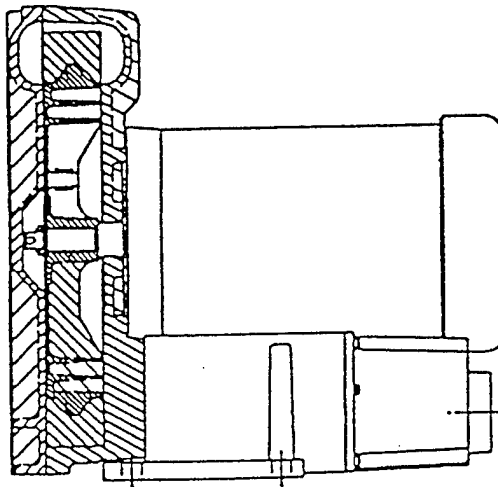

For original equipment manufacturers
special models, consult your local distributor

Gast Rebuilding Centers

Gast Mfg. Corp.
2550 Meadowbrook Rd.
Benton Harbor MI. 49022
Ph: 616/926-6171
Fax: 616/925-8288

Gast Mfg Corp.
505 Washington Avenue
Carlstadt, N. J. 07072
Ph: 201/933-8484
Fax: 201/933-5545

Brenner Fiedler & Assoc.
13824 Bentley Place
Cerritos, CA. 90701
Ph: 213/404-2721
Fax: 213/404-7975

Wainbee, Limited
121 City View Drive
Toronto, Ont. Canada M9W 5A9
Ph: 416/243-1900
Fax: 416/243-2336

Wainbee, Limited
215 Brunswick Drive
Pointe Claire, P.Q. Canada H9R 4R7
Ph: 514/697-8810
Fax: 514/697-3070

Gast Mfg. Co. Limited.
Halifax Rd, Cressex Estate
High Wycombe, Bucks HP12 3SN
Ph. 44 494 523571
Fax: 44 494 436588

Japan Machinery Co. Ltd.
Central PO Box 1451
Tokyo 100-91 Japan
Ph: 813/3573-5421
Fax: 813/3571-7865

Important Information on Gast Vacuum Pumps

Installation

It is important to include a vacuum gauge at the vacuum pump inlet in the air line within a few inches of the unit. Diagnosis of system problems is easier and more accurate with a gauge at this location. In reciprocating units, a "snubber" should be installed in the gauge connection to reduce pulsations which can damage the gauge.

The installation of a relief valve is equally important. Unit life is directly related to duty levels and most systems require only a fraction of the pump's advertised capacity to operate efficiently. The Gast (optional) relief valve makes it simple to "fine tune" the pump to minimum system needs, reducing electrical consumption and maximizing pump life.

Electric Motors

All electric motors supplied with Gast vacuum pumps are designed to operate at plus or minus 10% of nameplate voltage. Motors to meet special requirements are available upon request. Various brand-name motors are furnished on any model at the discretion of Gast.

Lubrication

Unless otherwise specified, every lubricated Gast unit is equipped with a standard lubrication system that automatically delivers the correct amount of oil to the pump. To provide correct lubrication, it is important to keep the oil reservoir filled.

In general, a reservoir holds enough oil for 25-50 hours of operation. Variables, such as duty level and ambient temperature, can cause significant variation from this range. However, an oil reservoir that needs refilling outside this range may indicate a malfunction in the lubrication system. Too much oil usage seldom does as much harm as insufficient lubrication. The most serious consequences of too fast an oil feed rate are oil fog or heavy oil condensation at the exhaust. A likely consequence of too slow an oil feed rate is complete pump failure.

Consult the factory before attempting to alter the feed rates of properly operating lubrication systems.

Unit Life Expectancy

Many variables determine the life expectancy of a unit. Among them are:

1. Ambient temperature
2. Duty level
3. Operating cycle
4. Operating speed
5. Condition of air handled
 - Cleanliness
 - Humidity
 - Heat
 - Chemical vapors present (corrosive, non-corrosive)
6. Unit maintenance
 - Lubrication
 - Filter maintenance
 - Muffler maintenance

As an example of the effect environment can have on pumps, consider this: Some Gast units are rated for 25,000 or more operating hours under controlled conditions, as in the Gast Engineering Department laboratory. The same model pumps, operating in the field under extremely adverse environmental conditions, have worn out in under 4,000 hours.

As a service to OEM customers, the Gast Engineering Department will predict the life expectancy of units used in OEM applications. Gast engineers will examine the units to predict life expectancy, after they have been used in the application for 4,000 hours.

Virtually all Gast units have lives much longer than 4,000 hours, a standard evaluation point for estimating total life expectancy. (DC Motor Brush life typically is less than 4,000 hours. It is best to consult the factory for further information.)

Ambient Temperature

A not-to-be-forgotten condition in applying compressors and vacuum pumps is ambient temperature. To determine the ambient temperature reading of the air surrounding the unit, readings should be taken around the unit approximately 4 inches away. Gast's

guarantee applies only to units operating within a temperature range of 32°F (0°C) to 100°F (38°C). Low temperature affects the unit's ability to start and high temperatures affect its life. Contact the factory for authorization of unusual ambient conditions.

This range is to be used as a guide and in no way means that things can't be done to allow units to be applied outside this temperature range. For example, additional external cooling, change the duty cycle and duty, provide better lubrication, etc. The ambient temperature range is generally for continuous operation but should also be followed for intermittent applications if normal unit life is to be expected.

Continuous vs. Intermittent Operation

Continuous vs. intermittent duty usually must be considered. Our definition of intermittent duty is 10 minutes or less on and 10 minutes or more off. Here again we are dealing with a very general statement. A better method of determining if the unit is applied properly is to measure temperatures of the metal portion of the unit that surrounds the discharge port and top dead center of the electric motor. Please note that when you refer to performance curves in this catalog, the solid line indicates continuous operation, while the dashed line shows intermittent duty.

Starting Under Load

- Rotary vane units will start under load. The vanes permit the internal chamber of the unit to bleed off during the cycle. At startup, the pump is not subjected to full load until enough centrifugal force has been attained to throw the vanes out against the body. By that time, the motor has gained enough momentum to continue its cycle without stress.
In systems where storage of built-up vacuum is important, check valves should be installed between the pump and the system.
- Blowers start up easily. Adequate internal clearances in Gast blowers make this possible.
- Oilless piston units will start under load as long as the top of the piston is not subjected to system vacuum. Under more complicated conditions, install a check valve next to the pump.
- Diaphragm units will not start under load because the surface area of the diaphragm is much larger than that of a piston pump. To start a diaphragm unit under load would require a motor too powerful to be cost effective. Instead, a specific volume of air at zero pressure differential must be provided to start the unit under load. (Specific volumes for different models are available from Gast.) Bleed orifices and dump valves are two common methods of supplying the correct zero-pressure-differential volume of air.
- ROC-R® rocking piston pumps use the same types of motors as diaphragm units and therefore the same conditions apply.

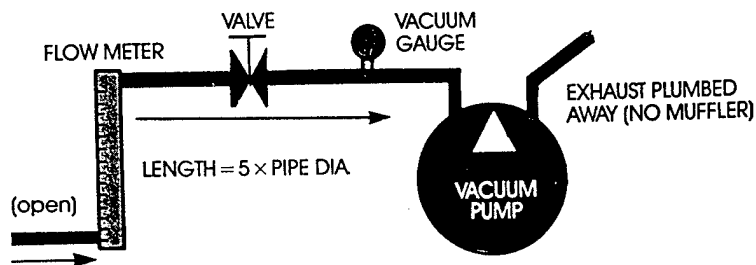

Catalog Performance Specifications

When looking at a Gast catalog performance chart, please remember that the specifications listed are that of a unit at sea level with an ambient temperature of 70°F (21°C), operating with normal electrical current conditions.

Performance shown in this catalog is the nominal to be expected from these models without accessories. Intake filters and exhaust mufflers, and the accumulation of contaminants in them during operation, will decrease the flow of air as well as the achievable vacuum by the vacuum pump.

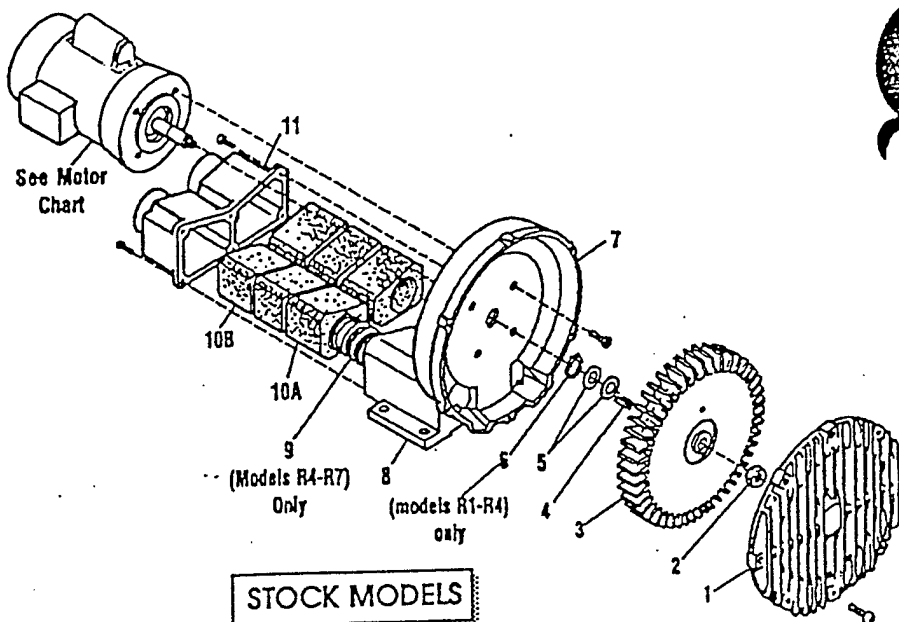

STOCK MODELS

Part Name	R1	R2	R3	R4	R5	R6	R6P	R6PP/R6PS	R7
#1 Cover	AJ101A	AJ101B	AJ101C	AJ101D	AJ101EQ	AJ101F	AJ101K	(2)AJ101KA	AJ101G
#2 Stopnut	BC187	BC187	BC181	BC181	BC181	BC181	BC181	(2)BC182	BC183
#3 Impeller	AJ102A	AJ102BQ	AJ102C	AJ102D	AJ102E	AJ102FR	AJ102K	(2)AJ102KA	AJ102GA
#4 Square Key	AH212C	AH212	AB136A	AB136D	AB136	AB136	AB136	(2)AB136	AC628
#5 Shim Spacer (s)	AJ132	AE686-3	AJ109	AJ149	AJ109	AJ109	AJ116A	AJ116A	AJ110
#6 Retaining Ring	AJ145	AJ145	AJ149	AJ149					
#7 Housing	AJ103A	AJ103BQ	AJ103C	AJ103DR	AJ103E	AJ103F	AJ103K	AJ103KD	AJ103GA
#8 Muffler Box					AJ104E	AJ104F			
#9 Spring				AJ113DR	AJ113DQ	AJ113FQ	AJ113FQ		AJ113G
#10A Foam	(4)AJ112A	(4)AJ112B	(4)AJ112C	(4)AJ112DS	(4)AJ112ER	(6)AJ112F	(8)AJ112K		(8)AJ112GA
#10B Foam		(2)AJ112BQ	(2)AJ112CQ	(2)AJ112DR	(2)AJ112EQ				
#11 Muffler Extension/ Adapter Plate	AJ106H	AJ106BQ	AJ106CQ	AJ106DQ	AJ106EQ	AJ106EQ	AJ104K		AJ104GA K395
Shim Kit	K396	K396							

MOTOR CHART

REGENAIR MODEL NUMBER	MOTOR NUMBER	MOTOR SPECIFICATIONS		PHASE
		60 HZ VOLTS	50 HZ VOLTS	
R1102	J111X	115/208-230	110/220-240	1
R1102C	J112X	115		1
R2103	J311X	115/208-230	110/220	1
R2105	J411X	115/208-230	110/220	1
R2303A	J310	208-230/460	220/380-415	3
R2303F	J313	208-230	220	3
R3105-1/R3105-12	J411X	115/208-230	110/220-240	1
R3305A-1/R3305A-13	J410	208-230/460	220/380-415	3
R4110-2	J611AX	115/208-230	110/220-240	1
R4310A-2	J610	208-230/460	220/380-415	3
R5125-2	J811X	115/208-230		1
R5325A-2	J810X	208-230/460	220/380-415	3
R6125-2	J811X	115/208-230		1
R6325A-2	J810X	208-230/460	220/380-415	3
R6335A-2	J910X	208-230/460	220/380-415	3
R6150J-2	J1013	230		1
R6350A-2	J1010	208-230/460	220/380-415	3
R6P335A	J910X	208-230/460	220/380-415	3
R6P350A	J1010	208-230/460	220/380-415	3
R6P355A	J1110A	208-230/460	220/380-415	3
R7100A-2	J1210B	208-230/460	220/380-415	3
R6PP/R6PS3110M	JD1100	208-230/460	220/380-415	3

* No lubrication needed at start up. Bearings lubricated at factory.

* Motor is equipped with demite fitting. Clean tip of fitting and apply grease gun. Use 1 to 2 strokes of high quality ball bearing grease.

Consistency	Type	Typical Grease
Medium	Lithium	Shell Dolum R

Hours of service per year	Suggested Relube Interval
5,000	3 years
Continual Normal Application	1 year
Seasonal service motor idle for 6 months or more	1 year beginning of season 6 months

Continuous-high ambient, dirty or moist applications.

All performance figures relate to stock models. A few high pressure units may be available. Consult your local distributor.

Regenair Model Number	PRESSURE						Maximum Pressure "H ₂ O"
	0"H ₂ O	20"H ₂ O	40"H ₂ O	60"H ₂ O	80"H ₂ O	100"H ₂ O	
R1	26	14					28
R2	42	26					38
R3105-1	52	38	14				42
R3105-12	52	36	23				55
R3305A-13	52	36	23				55
R4	90	70	50				52
R5	145	130	100				65
R6125-2	200	180					35
R6325A-2	200	180	152				40
R6335A-2	205	175	155	135			70
R6350A-2	200	180	150	130	110	80	105
R6P335A	290	250					30
R6P350A	300	260	230	200			60
R6P355A	300	260	230	200	160		90
R7100A-2	420	380	340	310	280	230	115
R6PP311OM	485	452	420	380	330		95
R6PS311OM	265	258	252	244	236	226	170

Regenair Model Number	VACUUM					Maximum Vacuum "H ₂ O"
	0"H ₂ O	20"H ₂ O	40"H ₂ O	60"H ₂ O	80"H ₂ O	
R1	25	14				26
R2	40	22				34
R3105-1	50	34	9			40
R3105-12	51	34	20			50
R3305A-13	51	34	20			50
R4	82	62	39			48
R5	140	115	90	50		60
R6125-2	190	155	125			45
R6325A-2	190	155	125			45
R6335A-2	190	150	125	100		75
R6350A-2	190	180	150	100	70	90
R6P335A	270	230				37
R6P350A	280	240	210	170		70
R6P355A	280	240	210	170	100	86
R7100A-2	410	350	300	250	170	90
R6PP311OM	470	425	375	320	220	80
R6PS311OM	240	225	210	195	175	130

*This number indicates the maximum static pressure differential recommended (with cooling air still flowing through unit). In general, units 1hp or less can be dead headed. Check with local representative or distributor to verify which models apply.

Operation of the blower above the recommended maximum duty will cause premature failure due to the build up of heat damaging the components.

Performance data was determined under the following conditions:

- 1) Unit in a temperature stable condition.
- 2) Test conditions: Inlet air density at 0.075lbs. per cubic foot. (20°C(68°F), 29.92 in. Hg(14.7PSIA)).
- 3) Normal performance variations on the resistance curve within +/- 10% of supplied data can be expected.
- 4) Specifications subject to change without notice.
- 5) All performance at 60Hz operation.

Oiless Regenerative Blower, Motor Mounted to 270 cfm



R6P Series

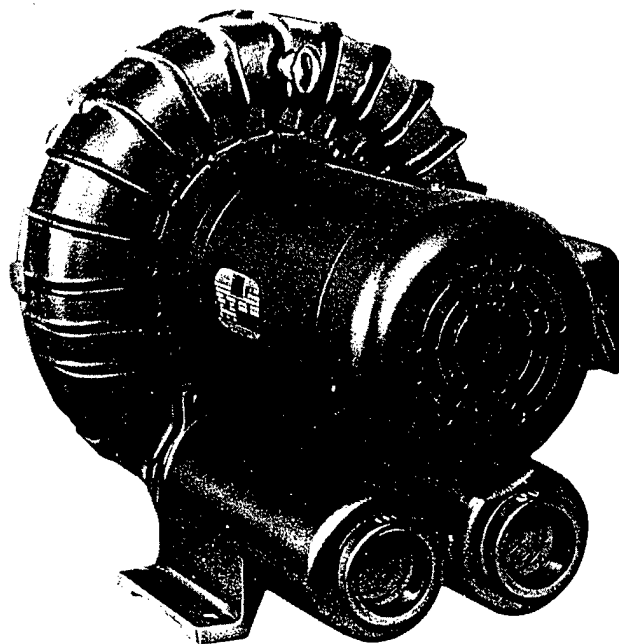

MODEL R6P335A
35" H₂O MAX. VAC., 270 CFM OPEN FLOW

MODEL R6P350A
70" H₂O MAX. VAC., 270 CFM OPEN FLOW

MODEL R6P355A
90" H₂O MAX. VAC., 260 CFM OPEN FLOW

PRODUCT FEATURES

- Oilless operation
- TEFC motor mounted
- Can be mounted in any plane
- Rugged construction/low maintenance

COMMON MOTOR OPTIONS

- 208-230/460V, 60 Hz; 190-220/380-415V, 50 Hz, three phase

RECOMMENDED ACCESSORIES

- Vacuum gauge AE134
- In-line filter AJ151G
- Muffler AJ121F
- Relief valve AG258

Various brand name motors are used on any model at the discretion of Gast Mfg. Corp.

Product Dimensions Metric (mm) U.S. Imperial (inches)

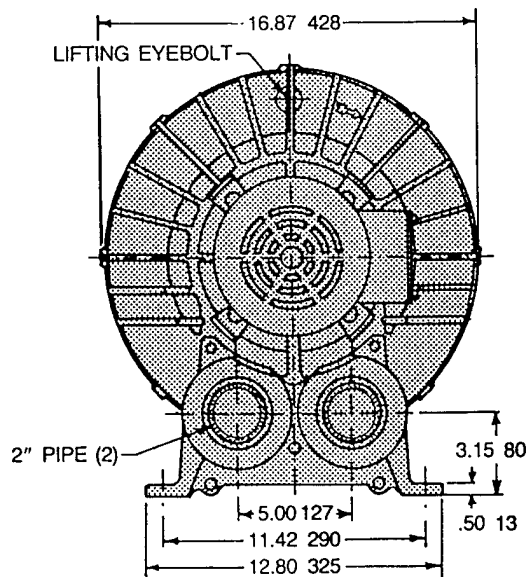
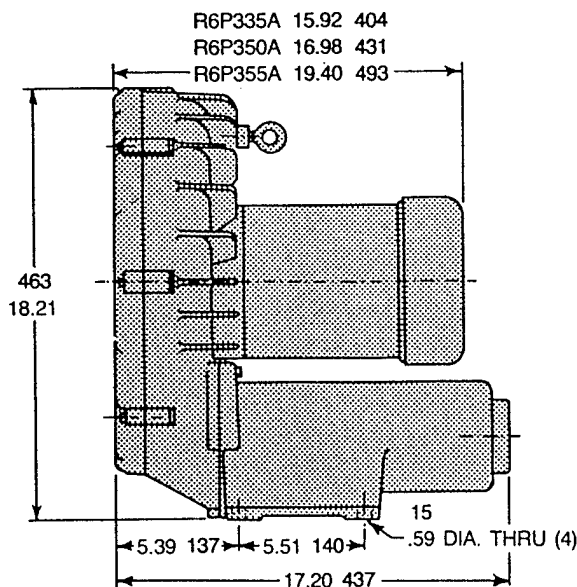

Important Notice:

Pictorial and dimensional data is subject to change without notice.

Product Specifications

Model Number	Motor Specs	Full Load Amps	HP	RPM	Max Vac		Max Flow		Net Wt.	
					"H ₂ O	mbar	cfm	m ³ /h	lbs.	kg
R6P335A	190-220/380-415-50-3	8-8/4-3.9	2½	2850	60	149	235	400	150	68
	208-230/460-60-3	9.7-8.8/4.4	3½	3450	35	87	270	459		
R6P350A	190-220/380-415-50-3	14.4-13.4/7.2-6.8	4½	2850	70	174	235	400	176	80
	208-230/460-60-3	13.0-12.0/6.0	5	3450	70	174	270	459		
R6P355A	190-220/380-415-50-3	14.2-13.4/7.1	5	2850	70	174	225	382	215	98
	208-230/460-60-3	19.5-18.2/9.1	5½	3450	90	224	260	442		

Product Performance (Metric U.S. Imperial)

Black line on curve is for 60 cycle performance.
Blue line on curve is for 50 cycle performance.

R6P335A

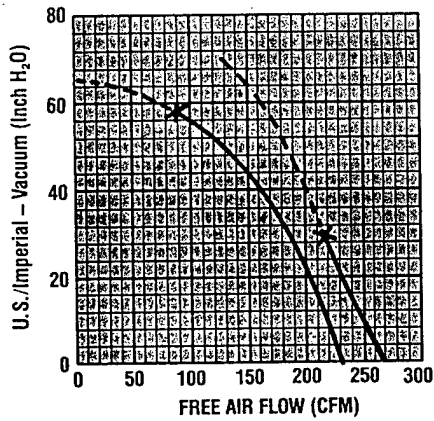
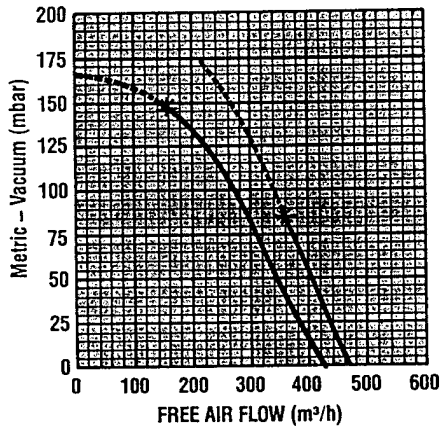

R6P350A

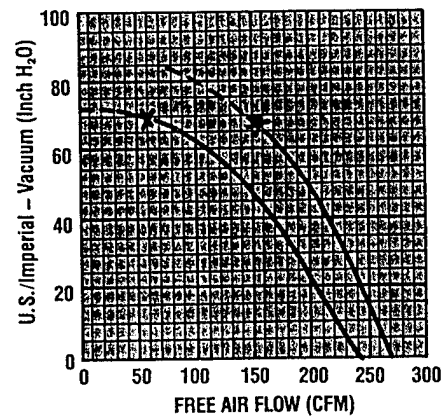
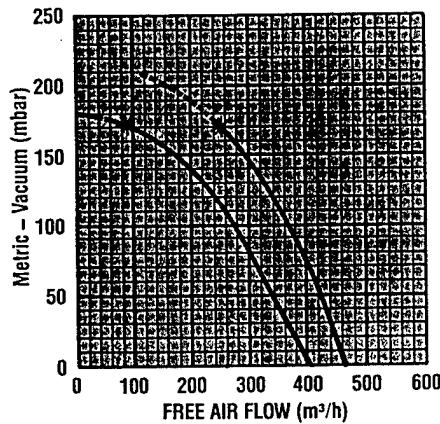

R6P355A

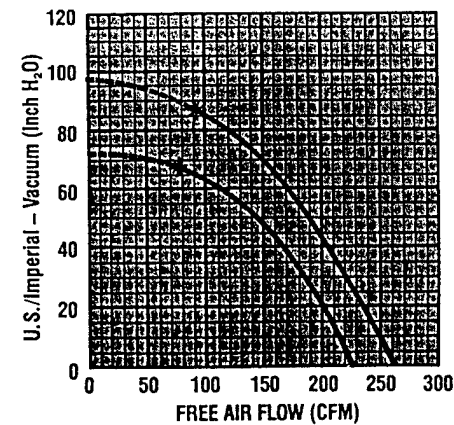
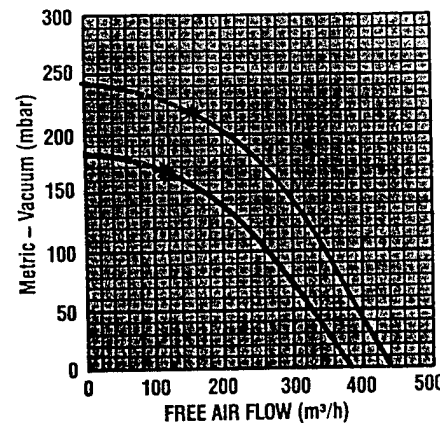

Model R6P355R-50

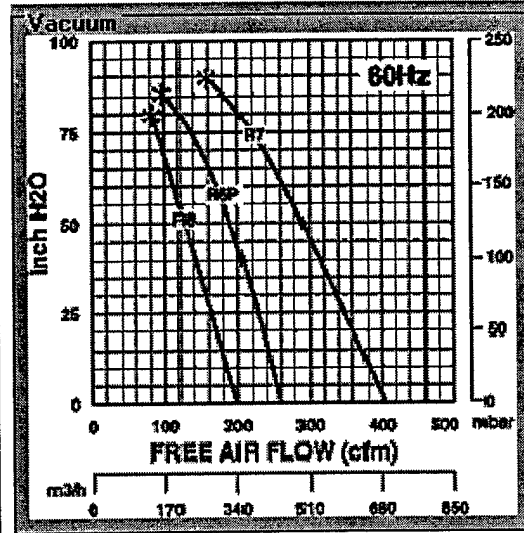
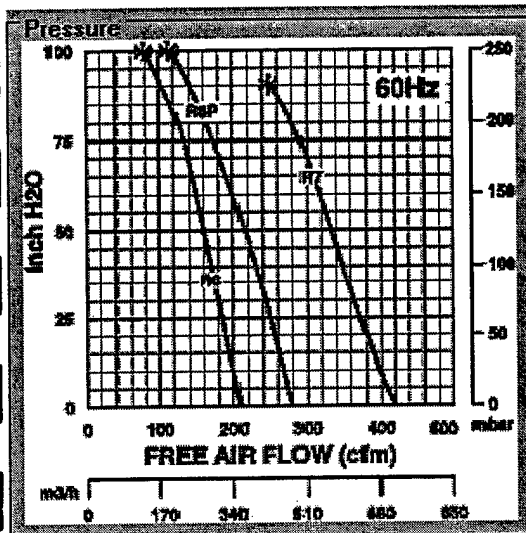

Print Curves

Close This Window

Gast Manufacturing Corp.
P.O. Box 97
Benton Harbor, MI 49023-0097
(616) 926-6171

You input the following requirements:

Estimated Vacuum in inches of water: 9
Estimated Pressure in inches of water: 85
Minimum Flow Required in cubic feet per minute: 110
Approximate temperature of the inlet air in degrees Fahrenheit: 20
Approximate altitude in feet above sea level: 3425
Motor Phase: 3
Assume 60 HZ operation

Based on these inputs, we have calculated the following:

Two Models R4310N-50 in series produce an air flow of 37 c.f.m.
Model R6340R-50 produces an air flow of 92 c.f.m.

RECOMMENDATION:
Model R6P355R-50, which will deliver an air flow of 138 c.f.m. in these conditions.

Accessories and Additional Recommendations

RECOMMENDED ACCESSORIES:
VACUUM SERVICE: Gast In-line filter AJ151G.
MOISTURE SEPARATOR: Gast RMS300 (19 gal).
VACUUM GAUGE: Gast AE134.
PRESSURE GAUGE: Gast AE133.
CHECK VALVE: Gast AH326F.

Gast Manufacturing Corp.
P.O. Box 97
Benton Harbor, MI 49023-0097
(616) 926-6171

You input the following requirements:

Estimated Vacuum in inches of water: 10
Estimated Pressure in inches of water: 80
Minimum Flow Required in cubic feet per minute: 110
Approximate temperature of the inlet air in degrees Fahrenheit: 20
Approximate altitude in feet above sea level: 3425
Motor Phase: 3
Assume 60 HZ operation

Based on these inputs, we have calculated the following:

Two Models R4310N-50 in series produce an air flow of 40 c.f.m.
Model R6340R-50 produces an air flow of 100 c.f.m.

RECOMMENDATION:
Model R6P355R-50, which will deliver an air flow of 146 c.f.m. in these conditions.

Accessories and Additional Recommendations

RECOMMENDED ACCESSORIES:
VACUUM SERVICE: Gast In-line filter AJ151G.
MOISTURE SEPARATOR: Gast RMS300 (19 gal).
VACUUM GAUGE: Gast AE134.
PRESSURE GAUGE: Gast AE133.
CHECK VALVE: Gast AH326F.

Gast Manufacturing Corp.
P.O. Box 97
Benton Harbor, MI 49023-0097
(616) 926-6171

You input the following requirements:

Estimated Vacuum in inches of water: 9
Estimated Pressure in inches of water: 85
Minimum Flow Required in cubic feet per minute: 110
Approximate temperature of the inlet air in degrees Fahrenheit: 30
Approximate altitude in feet above sea level: 3425
Motor Phase: 3
Assume 60 HZ operation

Based on these inputs, we have calculated the following:

Two Models R4310N-50 in series produce an air flow of 35 c.f.m.
Model R6340R-50 produces an air flow of 87 c.f.m.

RECOMMENDATION:
Model R6P355R-50, which will deliver an air flow of 133 c.f.m. in these conditions.

Accessories and Additional Recommendations

RECOMMENDED ACCESSORIES:
VACUUM SERVICE: Gast In-line filter AJ151G.
MOISTURE SEPARATOR: Gast RMS300 (19 gal).
VACUUM GAUGE: Gast AE134.
PRESSURE GAUGE: Gast AE133.
CHECK VALVE: Gast AH326F.

Gast Manufacturing Corp.
P.O. Box 97
Benton Harbor, MI 49023-0097
(616) 926-6171

You input the following requirements:

Estimated Vacuum in inches of water: 9
Estimated Pressure in inches of water: 80
Minimum Flow Required in cubic feet per minute: 100
Approximate temperature of the inlet air in degrees Fahrenheit: 60
Approximate altitude in feet above sea level: 3425
Motor Phase: 3
Assume 60 HZ operation

Based on these inputs, we have calculated the following:

Two Models R4310N-50 in series produce an air flow of 34 c.f.m.
Model R6340R-50 produces an air flow of 85 c.f.m.

RECOMMENDATION:
Model R6P355R-50, which will deliver an air flow of 132 c.f.m. in these conditions.

Accessories and Additional Recommendations

RECOMMENDED ACCESSORIES:
VACUUM SERVICE: Gast In-line filter AJ151G.
MOISTURE SEPARATOR: Gast RMS300 (19 gal).
VACUUM GAUGE: Gast AE134.
PRESSURE GAUGE: Gast AE133.
CHECK VALVE: Gast AH326F.



70-6100
F2-205/8/92
Rev. E

Post Office Box 97
Benton Harbor, MI. 49023-0097
Ph: 616/926-6171
Fax: 616/925-8288

INSTALLATION AND OPERATING INSTRUCTIONS FOR GAST HAZARDOUS DUTY REGENAIR BLOWERS

This instruction applies to the following models ONLY: R3105N-50, R4110N-50, R4310P-50, R4P115N-50, R5125Q-50, R5325R-50, R6130Q-50, R6P155Q-50, R6350R-50, R6P355R-50 and R7100R-50.

Gast Authorized Service Facilities are Located in the locations listed below

Gast Manufacturing Corporation
505 Washington Avenue
Carlstadt, N. J. 07072
Ph: 201/933-8484
Fax: 201/933-5545

Gast Manufacturing Corporation
2550 Meadowbrook Road
Benton Harbor, MI. 49022
Ph: 616/926-6171
Fax: 616/925-8288

Brenner Fiedler & Associates
13824 Bentley Place
Cerritos, CA. 90701
Ph: 310/404-2721
Ph: 800/843-5558
Fax: 310/404-7975

Wainbee Limited
215 Brunswick Blvd.
Pointe Claire, Quebec
Canada H9R 4R7
Ph: 514/697-8810
Fax: 514/-697-3070

Wainbee Limited
5789 Coopers Ave.
Mississauga, Ontario
Canada L4Z 3S6
Ph: 416/243-1900
Fax: 416/243-2336

Japan Machinery
Central PO Box 1451
Toyko 100-91, Japan
Ph: 813 3573-5421
Fax: 813 3571-7896

Gast Manufacturing Co. Ltd.
Hallfax Road, Cressex Estate
High Wycombe, Bucks HP12 3SN
England
Ph: 44 494 523571
Fax: 44 494 436588.

OPERATING AND MAINTENANCE INSTRUCTIONS

SAFETY

This is the safety alert symbol. When you see this symbol personal injury is possible. The degree of injury is shown by the following signal words:

- ⚠ **DANGER** Severe injury or death will occur if hazard is ignored.
- ⚠ **WARNING** Severe injury or death can occur if hazard is ignored.
- ⚠ **CAUTION** Minor injury or property damage can occur if hazard is ignored.

Review the following information carefully before operating.

GENERAL INFORMATION

This instruction applies to the following models ONLY: R3105N-50, R4110N-50, R4310P-50, R4P115N-50, R5125Q-50, R5325R-50, R6130Q-50, R6P155Q-50, R6350R-50, R6P355R-50 and R7100R-50. These blowers are intended for use in Soil Vapor Extraction Systems. The blowers are sealed at the factory for very low leakage. They are powered with a U.L. listed electric motor Class 1 Div. 1 Group D motors for Hazardous Duty locations. Ambient temperature for normal full load operation should not exceed 40° C (105° F). For higher ambient operation, contact the factory.

Gast Manufacturing Corporation may offer general application guidance: however, suitability of the particular blower and/or accessories is ultimately the responsibility of the user, not the manufacturer of the blower.

INSTALLATION

⚠ **DANGER** Models R5325R-50, R6130Q-50, R6350R-50, R5125Q-50, R6P155Q-50, R6P355R-50 AND R7100R-50 use Pilot Duty Thermal Overload Protection. Connecting this protection to the proper control circuitry is mandated by UL674 and NEC501. Failure to do so could result in a **EXPLOSION**. See pages 3 and 4 for recommended wiring schematic for these models.

⚠ **WARNING** Electric shock can result from bad wiring. A qualified person must install all wiring, conforming to all required safety codes. Grounding is necessary.

⚠ **WARNING** This blower is intended for use on soil vapor extraction equipment. Any other use must be approved in writing by Gast Manufacturing Corp. Install this blower in any mounting position. Do not block the flow of cooling air over the blower and motor.

PLUMBING - Use the threaded pipe ports for connection only. They will not support the plumbing. Be sure to use the same or larger size pipe to prevent air flow restriction and overheating of the blower. When installing fittings, be sure to use pipe thread sealant. This protects the threads in the blower housing and prevents leakage. Dirt and chips are often found in new plumbing. Do not allow them to enter the blower.

NOISE - Mount the unit on a solid surface that will not increase the sound. This will reduce noise and vibration. We suggest the use of shock mounts or vibration isolation material for mounting.

ROTATION - The Gast Regenair Blower should only rotate clockwise as viewed from the electric motor side. The casting has an arrow showing the correct direction. Confirm the proper rotation by checking air flow at the IN and OUT ports. If needed reverse rotation of three phase motors by changing the position of any two of the power line wires.

OPERATION

⚠ **WARNING** Solid or liquid material exiting the blower or piping can cause eye damage or skin cuts. Keep away from air stream.

⚠ **WARNING** - Gast Manufacturing Corporation will not knowingly specify, design or build any blower for installation in a hazardous, combustible or explosive location without a motor conforming to the proper NEMA or U. L. standards. Blowers with standard TEFC motors should never be utilized for soil vapor extraction applications or where local state and/or Federal codes specify the use of explosion-proof motors (as defined by the National Electric Code, Articles 100,500 c1990).

⚠ **CAUTION** Attach blower to solid surface before starting to prevent injury or damage from unit movement. Air containing solid particles or liquid must pass through a filter before entering the blower. Blowers must have filters, other accessories and all piping attached before starting. Any foreign material passing through the blower may cause internal damage to the blower.

⚠ **CAUTION** Outlet piping can burn skin. Guard or limit access. Mark "CAUTION Hot Surface. Can Cause Burns". Air temperature increases when passing through the blower. When run at duties above 50 in. H₂O metal pipe may be required for hot exhaust air. The blower must not be operated above the limits for continuous duty. Only models R3105N-50, R4110N-50 and R4310P-50 can be operated continuously with no air flowing through the blower. Other units can only be run at the rating shown on the model number label. Do not Close off inlet (for vacuum) to reduce extra air flow. This will cause added heat and motor load. Blower exhaust air in excess of 230°F indicates operation in excess of rating which can cause the blower to fail.

ACCESSORIES...Gast pressure gauge AJ496 and vacuum gauges AJ497 or AE134 show blower duty. The Gas pressure/vacuum relief valve, AG258, will limit the operating duty by admitting or relieving air. It also allows full flow through the blower when the relief valve closes.

SERVICING

⚠ WARNING To retain their sealed construction they should be serviced by Gast authorized service centers ONLY. These models are sealed at the factory for very low leakage.

⚠ WARNING Turn off electric power before removing blower from service. Be sure rotating parts have stopped. Electric shock or severe cuts can result. Inlet and exhaust filters attached to the blower may need cleaning or replacement of the elements. Failure to do so will result in more pressure drop, reduced air flow and hotter operation of the blower.

The outside of the unit requires cleaning of dust and dirt. The inside of the blower also may need cleaning to remove foreign material coating the impeller and housing. This should be done at a Gast Authorized Service Center. This buildup can cause vibration, failure of the motor to operate or reduced flow.

KEEP THIS INFORMATION WITH THIS BLOWER. REFER TO IT FOR SAFE INSTALLATION, OPERATION OR SERVICE.

MOTOR WIRING DIAGRAM FOR R4110N-50 & R3105N-50

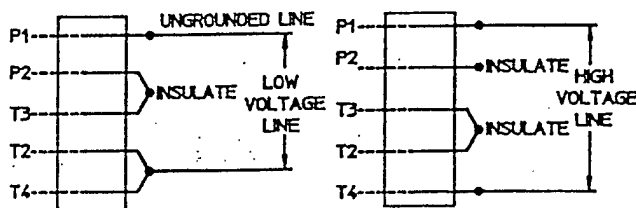

>> * WARNING
THIS MOTOR IS THERMALLY PROTECTED AND WILL AUTOMATICALLY RESTART WHEN PROTECTOR RESETS. ALWAYS DISCONNECT POWER SUPPLY BEFORE SERVICING.

MOTORS WIRING DIAGRAM FOR R4310P-50

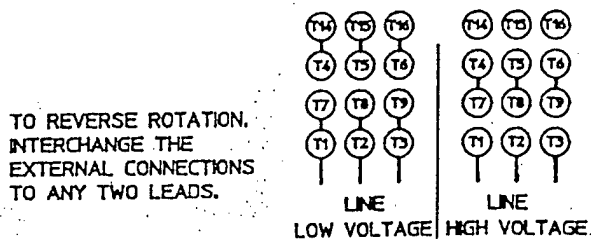

>> * WARNING
THIS MOTOR IS THERMALLY PROTECTED AND WILL AUTOMATICALLY RESTART WHEN PROTECTOR RESETS. ALWAYS DISCONNECT POWER SUPPLY BEFORE SERVICING.

MOTORS WIRING DIAGRAM FOR R5325R-50, R6350R-50, R6P355R-50, & R7100R-50

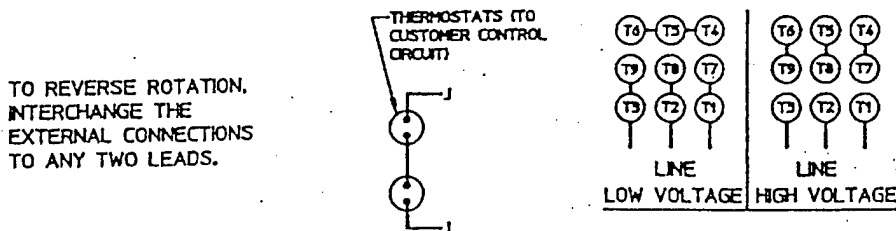

SERVICING

⚠ WARNING To retain their sealed construction they should be serviced by Gast authorized service centers ONLY. These models are sealed at the factory for very low leakage.

⚠ WARNING Turn off electric power before removing blower from service. Be sure rotating parts have stopped. Electric shock or severe cuts can result. Inlet and exhaust filters attached to the blower may need cleaning or replacement of the elements. Failure to do so will result in more pressure drop, reduced air flow and hotter opera-

tion of the blower. The outside of the unit requires cleaning of dust and dirt. The inside of the blower also may need cleaning to remove foreign material coating the impeller and housing. This should be done at a Gast Authorized Service Center. This buildup can cause vibration, failure of the motor to operate or reduced flow.

**KEEP THIS INFORMATION WITH THIS BLOWER.
REFER TO IT FOR SAFE INSTALLATION,
OPERATION OR SERVICE.**

MOTOR WIRING DIAGRAM FOR R4110N-50 & R3105N-50

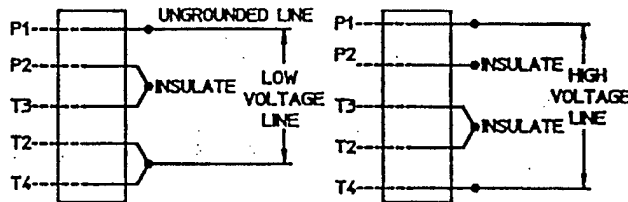

>>⚠ WARNING

THIS MOTOR IS THERMALLY PROTECTED AND WILL AUTOMATICALLY RESTART WHEN PROTECTOR RESETS. ALWAYS DISCONNECT POWER SUPPLY BEFORE SERVICING.

MOTORS WIRING DIAGRAM FOR R4310P-50

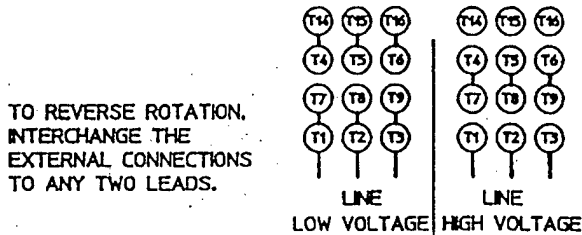

>>⚠ WARNING

THIS MOTOR IS THERMALLY PROTECTED AND WILL AUTOMATICALLY RESTART WHEN PROTECTOR RESETS. ALWAYS DISCONNECT POWER SUPPLY BEFORE SERVICING.

MOTORS WIRING DIAGRAM FOR R5325R-50, R6350R-50, R6P355R-50, & R7100R-50

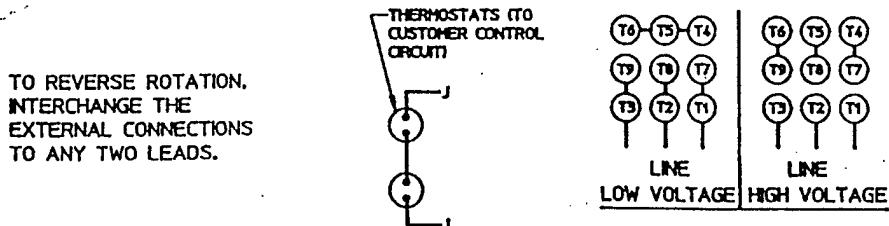

Relief Valve

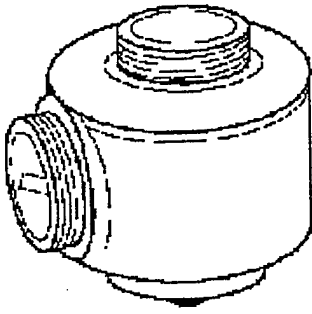

By setting a relief valve at a given pressure/vacuum, you can ensure excessive duties will not harm the blower or products in your application.

AG258	Relief valve	1½-inch NPT adjustable 30-200 inches H2O, vacuum or pressure, 200 CFM max
AG258F	Relief valve	2½-inch NPT adjustable 30-200 inches H2O, vacuum or pressure, 550 CFM max

[Print Form](#)

[Click Here for Catalog](#)

Gast Manufacturing Corp.
P.O. Box 97
Benton Harbor, MI 49023-0097
(616) 926-6171

Warranty

REGARDLESS OF CAUSE, if a product you buy from this brochure does not work right, Gast will repair or replace it once, at no charge, for up to one year from the date of shipment from the factory. In the course of repair or replacement, Gast may send you written recommendations on how to prevent a problem from happening again. Gast reserves the right to withdraw this warranty if you do not follow these recommendations. Customer is responsible for freight charges both to and from Gast in all cases. This warranty does not apply to electric motors, electrical controls, and gasoline engines, which Gast obtains from other manufacturers. A motor or engine carries only the warranty of the company that makes it.

THIS WARRANTY IS EXCLUSIVE AND IS IN LIEU OF ALL OTHER WARRANTIES, WHETHER WRITTEN, ORAL, OR IMPLIED, INCLUDING THE WARRANTY OF MERCHANTABILITY AND OF FITNESS FOR ANY PARTICULAR PURPOSE. GAST'S LIABILITY IS IN ALL CASES LIMITED TO THE REPLACEMENT PRICE OF ITS PRODUCT. GAST SHALL NOT BE LIABLE FOR ANY OTHER DAMAGES, WHETHER CONSEQUENTIAL, INDIRECT, OR INCIDENTAL, ARISING FROM THE SALE OR USE OF ITS PRODUCTS.

Gast's sales personnel may modify this warranty, but only by signing a specific, written description of any modifications.

Disclaimer

The information presented in this electronic catalog is based on technical data and test results of nominal units. It is believed to be accurate and is offered as an aid in the selection of Gast products. It is the user's responsibility to determine suitability of the product for his intended use and the user assumes all risk and liability whatsoever in connection therewith.



LOW PRESSURE GAUGES

Types 611.10 & 612.20

WIKA INSTRUMENT CORPORATION
 1000 Wiegand Boulevard
 Lawrenceville, Georgia 30243-5868
 (404) 513-8200 1-800-645-0608
 FAX: (404) 513-8203

PRICE LIST

Type 611.10 2 1/2" (63mm)
 Type 612.20 4" (100mm)

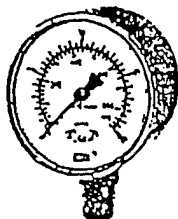

Standard Features

- Case: Black painted steel (611.10)
 Stainless steel (612.20)
- Bayonet Ring: None (2 1/2")
 Stainless steel (4")
- Wetted Parts: Copper alloy
- Window: Acrylic (2 1/2")
 Instrument glass (4")
- Dial: White aluminum
- Pointer: Black aluminum
- Accuracy: ± 1.5% of span
- Brass movement with highly polished bearing surfaces
- Recalibration screw on dial

Special Order Options

50 pcs. minimum order quantity per line item required (611.10)
 25 pcs. minimum order quantity per line item required (612.20)

- Custom Dials - Special scales and dial markings are available. Standard list prices apply. Add any applicable artwork/set-up charges. Refer to "Custom Dial Artwork Charges" (price page PL95-32).
- Special Connections - No additional charge for standard NPT or metric threads. Contact factory for other special threads.
- Gauge Accessories - Additional accessories may be available. Refer to "Pressure Gauge Accessories" (price page PL95-30).
- Additional Options Available -
 - Nickel or chrome plated connection
 - Lower back mount (Type 612.20 only)
 - Rear flange
 - U-clamp
 - Safety glass window
 - Stainless steel wetted parts 2 1/2" (631.10)
 - Stainless steel wetted parts 4" (632.50)
 - (refer to price page PL95-21 for prices)
 - Cleaned for oxygen service
 - Stainless steel case and ring
 - Red drag pointer

- Items with part numbers are available from stock (subject to prior sale).
- Please use applicable part numbers when ordering.
- Items shown without part numbers are available on special order at no additional charge. Above listed minimum order quantities per line item required. Contact factory for current lead times.

Prices subject to change without notice.
 This price list supersedes price list dated 01/01/95.
 Effective 05/01/95 or
 Price Page PL95-20

Type	611.10		612.20	
Size	2 1/2"		4"	
Connection	LM	CBM	LM	
Conn. Size	1/4" NPT			
Data Sheet	APM 06.01		APM 06.02	
List Price	\$43.25	\$47.55	\$139.15	
Vacuum Range (dual scale)				
	inch water	mm water		
	0-30	0-760	9852344	9851852 9747724
	0-60	0-1500	9748321	9748339
	0-100	0-2500	9747473	9747465
Pressure Ranges (dual scale)				
	inch water	mm water		
	0-15	0-380	9851682	9851860 9747732
	0-30	0-760	9851690	9855785 9747740
	0-60	0-1500	9851704	9803432 9747758
	0-100	0-2500	9851810	9851879 9747766
	0-200	0-5000	9851828	9851887 9747775
	oz./sq. in.	mm water		
	0-10	0-440	9851771	
	0-15	0-660	9851780	
	0-20	0-880	9851798	
	0-30	0-1320	9851747	9851917
	0-35	0-1540	9851801	9857273
	0-60	0-2640	9851755	9803548
	oz./sq. in.	in. water		
	0-20	0-34	9851720	9857281
	0-32	0-55	9851739	9855793
Pressure Ranges (single scale)				
	psi			
	3		9851925	9851836 9747783
	5		9851933	9851844 9747791
Accessories (installed)				
<small>Accessory prices do not apply to orders of 50 pcs or more per line item (25 pcs. for type 612.20). Contact factory for quote.</small>				
FF, chrome plated brass	\$27.55	\$21.55		N/A
	1327085	1327087		
FF, black painted steel	\$21.30	\$24.55		N/A
	1327089	1327091		
FF, stainless steel	--	--		\$23.65
				1327081
Restrictor, brass		\$.90		
		1326943		

ABBREVIATIONS
 LM - Lower Mount
 CBM - Center Back Mount
 FF - Front Flange
 N/A - Not Available

In keeping with and for purposes of product improvement, Wika reserves the right to make design changes without prior notice.

Prices: FOB Lawrenceville, GA
 Terms: 30 days net
 (subject to credit approval)

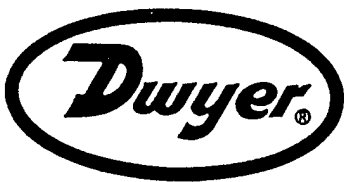

Dwyer Model 470-1 Handheld Thermal Anemometer

Measures air velocity to 6,000 feet per minute

±5% accuracy, but low cost.

Compact, light weight, easy to use.

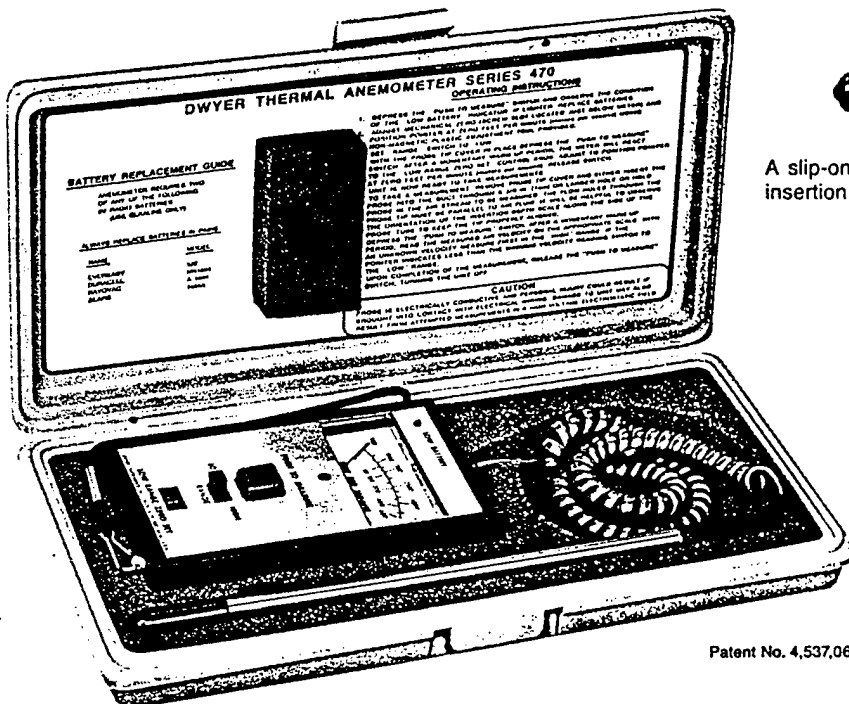

Foam padded polypropylene carrying case, included with the Model 470-1, has complete operating instructions inside the cover.

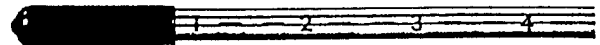

A slip-on cover protects the probe tip when not in use and a depth insertion scale on the probe body aids in making duct traverses.



Compact and lightweight, the Model 470-1 makes air velocity measurements in any location.

Patent No. 4,537,068

The versatility of the Dwyer Model 470-1 Handheld Thermal Anemometer makes it ideal for a wide range of air velocity measurements. Easy to carry and use in the field, the 470-1 can be used to balance heating and air conditioning systems, measure velocity in HVAC ducts, read fume and exhaust hood face velocities, as well as make wind speed measurements associated with agricultural, forestry, highway and recreational activities. This low cost battery powered electronic instrument provides two switch selected air velocity ranges of 0-600 FPM and 500-6000 FPM displayed on an easily read analog meter. Two standard 9 volt alkaline batteries provide eight hours of operating time (equivalent to over 5000 readings) and a convenient LED low-battery indicator avoids lost time on the job when battery replacement is required. Sophisticated temperature compensation circuitry maintains ±5% of full range accuracy over an air stream temperature of 30°F to 180°F. Secured by means of a wrist strap and held in either the right or left hand, the indicating unit provides easy one hand access to the range switch, zero adjust, and the push-to-measure switch. The opposite hand is free to insert the stainless steel probe into ducts up to a depth of 8" with probe insertion depth indicated by means of a scale etched on both sides of the probe body. The 1 foot coiled probe cord stretches to 5 feet for both convenient storage and operation. The spring return push-to-measure switch turns the unit off automatically after each reading to prevent unnecessary battery drain. The Model 470-1 Thermal Anemometer comes complete with a durable polypropylene, foam-lined carrying case with full operating instructions provided on the inside of the case lid.

SPECIFICATIONS:

Ranges: 0-600 FPM, 500-6000 FPM (0-3, 2-30 MPS metric).

Accuracy: ±5% of full scale.

Response time: 1 sec. for velocity change; 5 sec. for temperature change (in air moving over 50 FPM).

Temperature ranges:
Air stream: 32°F to 180°F.
Operating: 32°F to 160°F.
Storage: -22°F to 212°F.

Controls: Range switch
Push-to-measure switch
Zero adjust

Probe: #516 stainless steel, 10" long by 3/16" diameter with 8" insertion depth scale and tip shield.

Power: Two 9 volt alkaline transistor batteries.

Battery Life: 8 hours operating time in normal usage.

Weight: 13 oz. (unit only); 1 lb. 9 oz. (in carrying case).

Dimensions: Indicating unit 6" L x 3 3/8" W x 1 1/4" H; Carrying case 12 1/4" L x 6 3/8" W x 1 3/4" H.

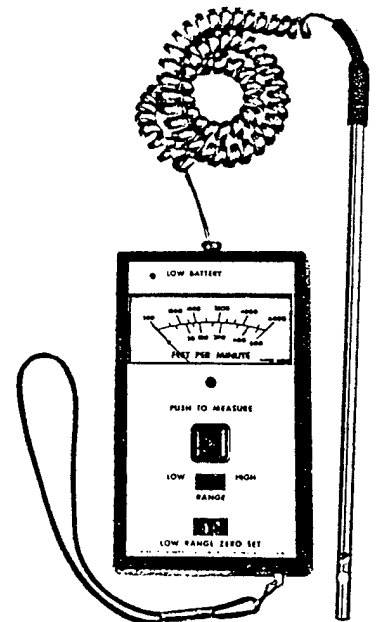

Wrist strap, coil cord, simple controls, and easy-to-read meter add up to real operating convenience.

APPENDIX C
DATA COLLECTION SHEETS

