

LOAN DOCUMENT

PHOTOGRAPH THIS SHEET

①

DTIC ACCESSION NUMBER

LEVEL

2 Part's

INVENTORY

Bioventing Pilot Test Work Plan Farmer ...

DOCUMENT IDENTIFICATION

Jul 94

DISTRIBUTION STATEMENT A
Approved for Public Release
Distribution Unlimited

DISTRIBUTION STATEMENT

DATE ACCESSIONED

DATE RETURNED

REGISTERED OR CERTIFIED NUMBER

DATE ACCESSIONED

DATE RETURNED

REGISTERED OR CERTIFIED NUMBER

ACCESSION TO

NTIS	GRAM	<input checked="" type="checkbox"/>
DTIC	TRAC	<input type="checkbox"/>
UNANNOUNCED		<input type="checkbox"/>
JUSTIFICATION		

BY

DISTRIBUTION/

AVAILABILITY CODES

DISTRIBUTION	AVAILABILITY AND/OR SPECIAL
A-1	

DISTRIBUTION STAMP

20010117 036

DATE RECEIVED IN DTIC

PHOTOGRAPH THIS SHEET AND RETURN TO DTIC-FDAC

H
A
N
D
L
E

W
I
T
H

C
A
R
E

PART I

**Bioventing Pilot Test Work Plan
Former Diesel UST Areas
Installation Restoration Program, Sites 35a & 35c
March AFB, California**

PART II

**Draft Bioventing Pilot Test Interim Results Report
Former Diesel UST Area
Installation Restoration Program, Site 35c
March AFB, California**

Prepared For

**Air Force Center for Environmental Excellence
Brooks AFB, Texas**

and

March AFB, California

ES

Engineering-Science, Inc.

July 1994

9404 Genesee Avenue, Suite 140
La Jolla, California 92037

AQ MOI-03-0728

ES ENGINEERING-SCIENCE

DEFENSE TECHNICAL INFORMATION CENTER REQUEST FOR SCIENTIFIC AND TECHNICAL REPORTS

Title AFCEE Collection

1. Report Availability (Please check one box)

- This report is available. Complete sections 2a - 2f.
- This report is not available. Complete section 3.

2a. Number of Copies Forwarded

1 each

2b. Forwarding Date

July/2000

2c. Distribution Statement (Please check ONE box)

DoD Directive 5230.24, "Distribution Statements on Technical Documents," 18 Mar 87, contains seven distribution statements, as described briefly below. Technical documents MUST be assigned a distribution statement.

- DISTRIBUTION STATEMENT A: Approved for public release. Distribution is unlimited.
- DISTRIBUTION STATEMENT B: Distribution authorized to U.S. Government Agencies only.
- DISTRIBUTION STATEMENT C: Distribution authorized to U.S. Government Agencies and their contractors.
- DISTRIBUTION STATEMENT D: Distribution authorized to U.S. Department of Defense (DoD) and U.S DoD contractors only.
- DISTRIBUTION STATEMENT E: Distribution authorized to U.S. Department of Defense (DoD) components only.
- DISTRIBUTION STATEMENT F: Further dissemination only as directed by the controlling DoD office indicated below or by higher authority.
- DISTRIBUTION STATEMENT X: Distribution authorized to U.S. Government agencies and private individuals or enterprises eligible to obtain export-controlled technical data in accordance with DoD Directive 5230.25, Withholding of Unclassified Technical Data from Public Disclosure, 6 Nov 84.

2d. Reason For the Above Distribution Statement (in accordance with DoD Directive 5230.24)

2e. Controlling Office

HQ AFCEE

2f. Date of Distribution Statement Determination

15 Nov 2000

3. This report is NOT forwarded for the following reasons. (Please check appropriate box)

- It was previously forwarded to DTIC on (date) and the AD number is
- It will be published at a later date. Enter approximate date if known.
- In accordance with the provisions of DoD Directive 3200.12, the requested document is not supplied because:

Print or Type Name

Laura Peña

Signature

Laura Peña

Telephone

210-536-1431

(For DTIC Use Only)

AQ Number

MDI-03-0728

CONTENTS

PART I

BIOVENTING PILOT TEST WORK PLAN

FORMER DIESEL UST AREAS

INSTALLATION RESTORATION PROGRAM, SITES 35a AND 35c

MARCH AFB, CALIFORNIA

	Page
1.0 INTRODUCTION	I-1
2.0 SITE DESCRIPTION	I-3
2.1 Former Diesel UST Area 35a	I-3
2.1.1 Site Location and History	I-3
2.1.2 Site Geology	I-3
2.1.3 Site Contaminants	I-3
2.2 Former Diesel UST Area 35c	I-5
2.2.1 Site Location and History	I-5
2.2.2 Site Geology	I-5
2.2.3 Site Contaminants	I-5
3.0 SITE-SPECIFIC ACTIVITIES	I-5
3.1 Site Layouts	I-7
3.2 Vent Wells	I-7
3.3 Monitoring Points	I-7
3.4 Handling of Drill Cuttings	I-13
3.5 Soil and Soil Gas Sampling	I-13
3.5.1 Soil Samples	I-13
3.5.2 Soil Gas Samples	I-15
3.6 Blower Systems	I-15
3.7 In Situ Respiration Tests	I-17
3.8 Air Permeability Tests	I-17
3.9 Air Emissions Monitoring	I-17
3.10 Installation of Extended (One-Year) Pilot Test Bioventing System	I-18
4.0 EXCEPTIONS TO PROTOCOL PROCEDURES	I-18
5.0 BASE SUPPORT REQUIREMENTS	I-18
6.0 PROJECT SCHEDULE	I-19
7.0 POINTS OF CONTACT	I-19
8.0 REFERENCES	I-20

FIGURES

Figure	Description	Page
1.1	March Air Force Base Map	I-2
2.1	Site Location Map, IRP Site 35a, Former Diesel UST Area	I-4
2.2	Site Location Map, IRP Site 35c, Former Diesel UST Area	I-6
3.1	Proposed Vent Well/Vapor Monitoring Point Locations IRP Site 35a, Former Diesel UST Area	I-8
3.2	Proposed Vent Well/Vapor Monitoring Point Locations IRP Site 35c, Former Diesel UST Area	I-9
3.3	Proposed Air Injection Vent Well Construction Details IRP Site 35a, Former Diesel UST Area	I-10
3.4	Proposed Air Injection Vent Well Construction Details IRP Site 35c, Former Diesel UST Area	I-11
3.5	Proposed Monitoring Point Construction Details IRP Site 35a, Former Diesel UST Area	I-12
3.6	Proposed Monitoring Point Construction Details IRP Site 35c, Former Diesel UST Area	I-14
3.7	Blower System Instrumentation Diagram for Air Injection IRP Sites 35a and 35c, Former Diesel UST Areas	I-16

PART I
BIOVENTING PILOT TEST WORK PLAN
FORMER DIESEL UST AREAS
INSTALLATION RESTORATION PROGRAM, SITES 35a AND 35c
MARCH AFB, CALIFORNIA

1.0 INTRODUCTION

This Pilot Test Work Plan presents the scope of two *in situ* bioventing pilot tests for the treatment of fuel-contaminated soils at two former diesel underground storage tank (UST) areas at Installation Restoration Program (IRP) Sites 35a and 35c, March Air Force Base (AFB), California (Figure 1.1). March AFB is located in Riverside County, approximately ten miles east of Riverside and sixty miles east of Los Angeles. Bioventing pilot tests have three primary objectives: (1) to assess the potential for supplying oxygen throughout the contaminated soil interval, (2) to determine the rate at which indigenous microorganisms will degrade fuel in the soil when stimulated by oxygen-rich soil gas, and (3) to evaluate the potential for sustaining these rates of biodegradation until fuel contamination is remediated to concentrations below regulatory standards.

Pilot tests will be conducted in two phases. The initial pilot test phase will include installation of vent wells (VW) and vapor monitoring points (MPs) at each site, followed by *in situ* respiration tests and air permeability tests. The initial pilot test will determine important design parameters such as air permeability, radius of influence, biodegradation rates, and potential air emissions quantities. It is anticipated that the duration of this initial testing will be approximately four weeks. If initial testing proves successful, an extended (one-year) testing phase will be initiated which will determine the longer term application of this remedial technology to degrade hydrocarbons at the above-mentioned sites.

If bioventing is determined to be feasible at these sites, pilot test data could be used to design and implement remediation systems and to estimate the time required for site cleanup. Since testing will take place within the most contaminated soils at each site, an added benefit of the pilot testing at former UST areas 35a and 35c is that a significant amount of the fuel contamination should be biodegraded during the extended (one-year) pilot tests.

Additional background information on the development and recent success of bioventing technology is found in the *Test Plan and Technical Protocol for a Field Treatability Test for Bioventing* (Hinchee, et al., 1992). This protocol document will

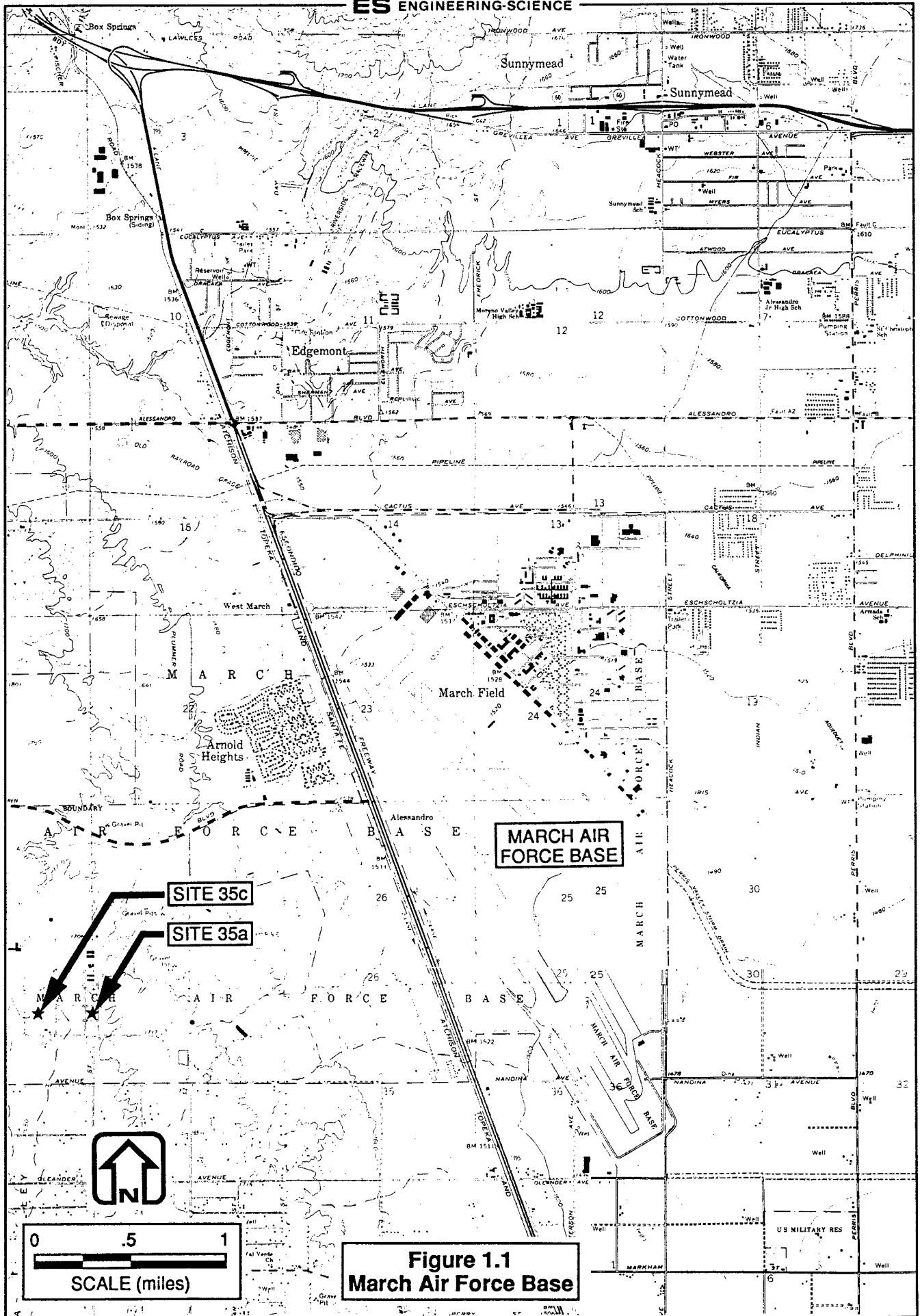

MARCH AIR FORCE BASE

SITE 35c

SITE 35a

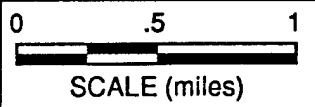

**Figure 1.1
March Air Force Base**

serve as the primary reference for the pilot test well design, and detailed procedures which will be used during the tests.

2.0 SITE DESCRIPTION

2.1 Former Diesel UST Area 35a

2.1.1 Site Location and History

The pilot test site at IRP Site 35a is the location of a former 8,000 gallon diesel fuel tank near the northeast corner of Building 3409. The building is located in West March, on Allen Avenue. The former diesel tank location, in respect to Building 3409, is shown in Figure 2.1.

Available site information does not indicate (1) when the diesel tank was removed, (2) the depth and extent of the tank excavation, (3) the nature of the backfill material, (4) the extent of *in situ* contamination left in place, or (5) the present site operation. The present surface of the former diesel tank location is grass. A 1988 study by Lee Wan & Associates, and a 1992 study by TetraTech, identified and confirmed the presence of diesel-contaminated soil associated with the former tank.

2.1.2 Site Geology

Site 35a lies on the Perris Surface. This area is typified by Cretaceous and older crystalline rock outcrops with shallow soil cover. The granitic rock of West March is often highly weathered at the contact with the soil cover. The thickness of the weathered zone is unknown. Groundwater is often present in this weathered zone.

Boring logs from previous site investigations indicate a 2- to 5-foot zone of sand and silty sand above decomposed granite. Sand ranges from fine to coarse grained, with minor amounts of silt, clay, and gravel. The decomposed granite is gray-brown to dark gray, and very wet to saturated at depth. Static groundwater at Site 35a was measured at approximately 29.6 feet below ground surface (bgs) in monitoring well 5M-35-MW-3 (Figure 2.1). Groundwater flow direction at the site has not yet been determined.

2.1.3 Site Contaminants

The primary contaminant documented in soils at this site is petroleum hydrocarbons in the diesel range (TPH-d). TPH-d (as indicated by EPA 8015 Modified for Diesel) has been detected in the soil at depths from 5 to 25 feet bgs, with concentrations ranging from 81 to 4,640 mg/kg. Concentrations above detection limits were found in only two borings, BH-12 and 5M-35-B2. Figure 2.1 shows the location of existing borings in respect to the approximate former tank location.

It appears that most of the contamination is confined to the tank bed, or is in close proximity to the former tank excavation. Analysis of groundwater samples at Site 35a revealed no detectable concentrations of petroleum hydrocarbons.

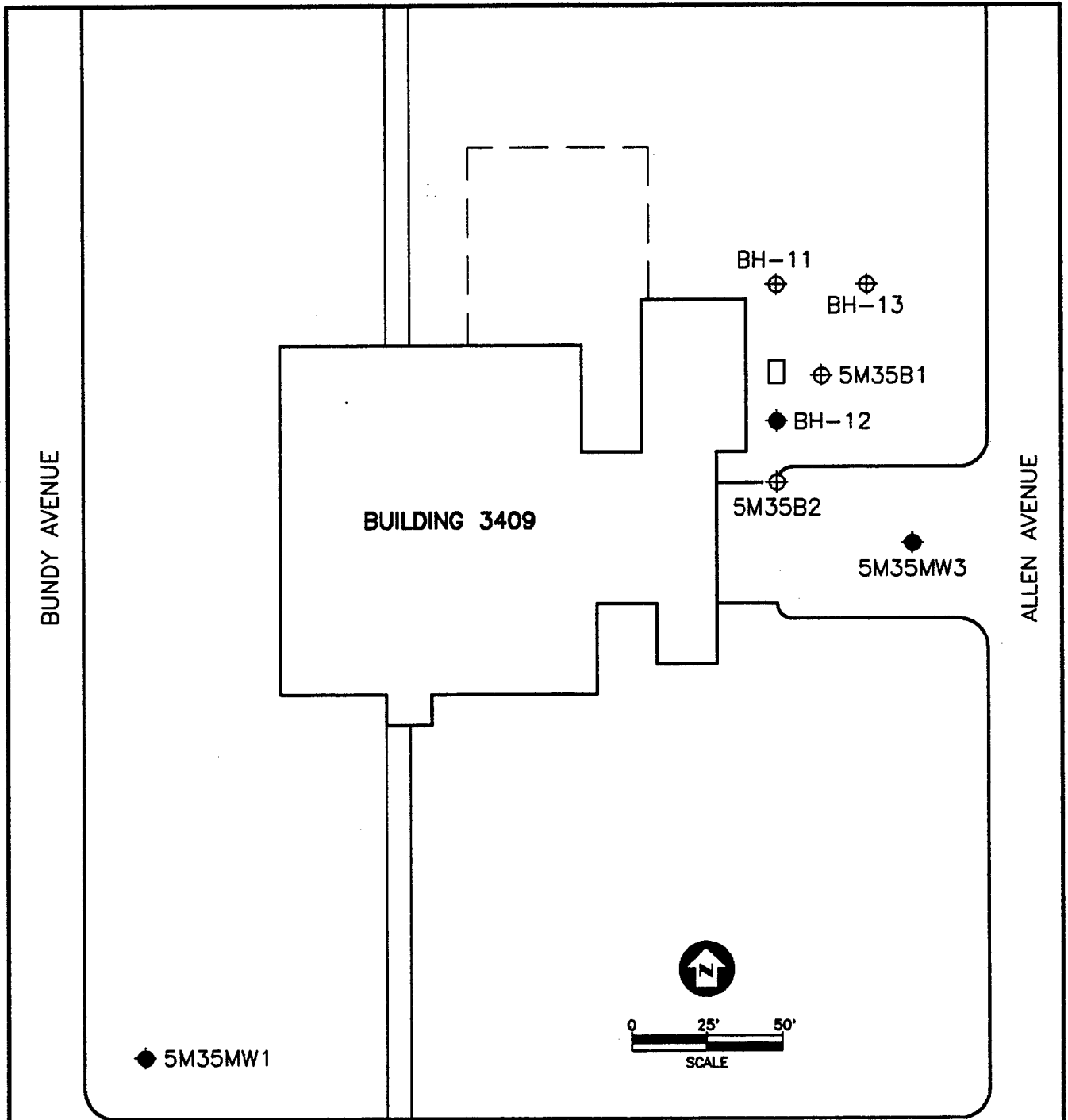

LEGEND	
⊕	EXISTING BORING
◆	EXISTING MONITORING WELL
□	FORMER 8,000 GAL. DIESEL TANK

FIGURE 2.1

SITE LOCATION MAP
IRP SITE 35A
FORMER DIESEL UST AREA

MARCH AFB, CALIFORNIA

ENGINEERING-SCIENCE, INC.
 La Jolla, California

ES

2.2 Former Diesel UST Area 35c

2.2.1 Site Location and History

The pilot test site at IRP Site 35c is the location of a former 1,000 gallon diesel fuel tank near the northeast corner of Building 3406. The building is located off Dalla Avenue in West March. The former diesel tank location, in respect to Building 3406, is shown in Figure 2.2.

As with Site 35a, it is unclear when the diesel tank was removed. Available site information does not indicate (1) the depth and extent of the tank excavation, (2) the nature of the backfill material, (3) the extent of *in situ* contamination left in place, or (4) the present site operation. The present surface of the former diesel tank location is grass and soil. A 1988 study by Lee Wan & Associates, and a 1992 study by TetraTech, identified and confirmed the presence of diesel-contaminated soil associated with the former tank.

2.2.2 Site Geology

The geology of Site 35c is very similar to that of 35a. A 2- to 5-foot-thick layer of sand and silty sand overlies highly weathered, granitic bedrock. The thickness of the weathered zone is unknown. Depth to groundwater was reported at approximately 18 feet bgs in monitoring well 5M-35-MW-2. Groundwater flow direction at the site has not yet been determined.

2.2.3 Site Contaminants

Petroleum hydrocarbons in the diesel range (as indicated by EPA 8015 Modified for Diesel) have been detected in soil samples collected from BH-19 (Figure 2.2). Concentrations of 696 mg/kg and 5,320 mg/kg were detected at 5 and 10 feet bgs, respectively. It appears that the majority of the site contamination is confined to the former tank bed. A groundwater sample from BH-19 showed petroleum hydrocarbon concentrations in the motor oil range of 1.02 mg/l. A sample from BH-20 was non-detect for petroleum hydrocarbons in the gasoline, diesel, and motor oil ranges.

3.0 SITE SPECIFIC ACTIVITIES

The purpose of this section is to describe the work that will be performed by Engineering-Science, Inc. (ES) at Sites 35a and 35c. Activities at each site will include: (1) siting and construction of a central air injection VW and three MPs; (2) an air permeability test; (3) an *in situ* respiration test; and (4) the implementation of an extended (one-year) bioventing pilot test. Soil and soil gas sampling procedures are described below. In addition, the blower configurations that will be used to inject air (oxygen) into contaminated soils through the VWs are also discussed in this section. No dewatering or groundwater treatment will take place during the pilot tests. Pilot test activities will be confined to the remediation of unsaturated soils. Existing monitoring wells will not be used as primary air injection wells; however, monitoring wells BH-12, BH-19, and BH-20 may be used as vapor MPs, or to measure the composition of background soil gas.

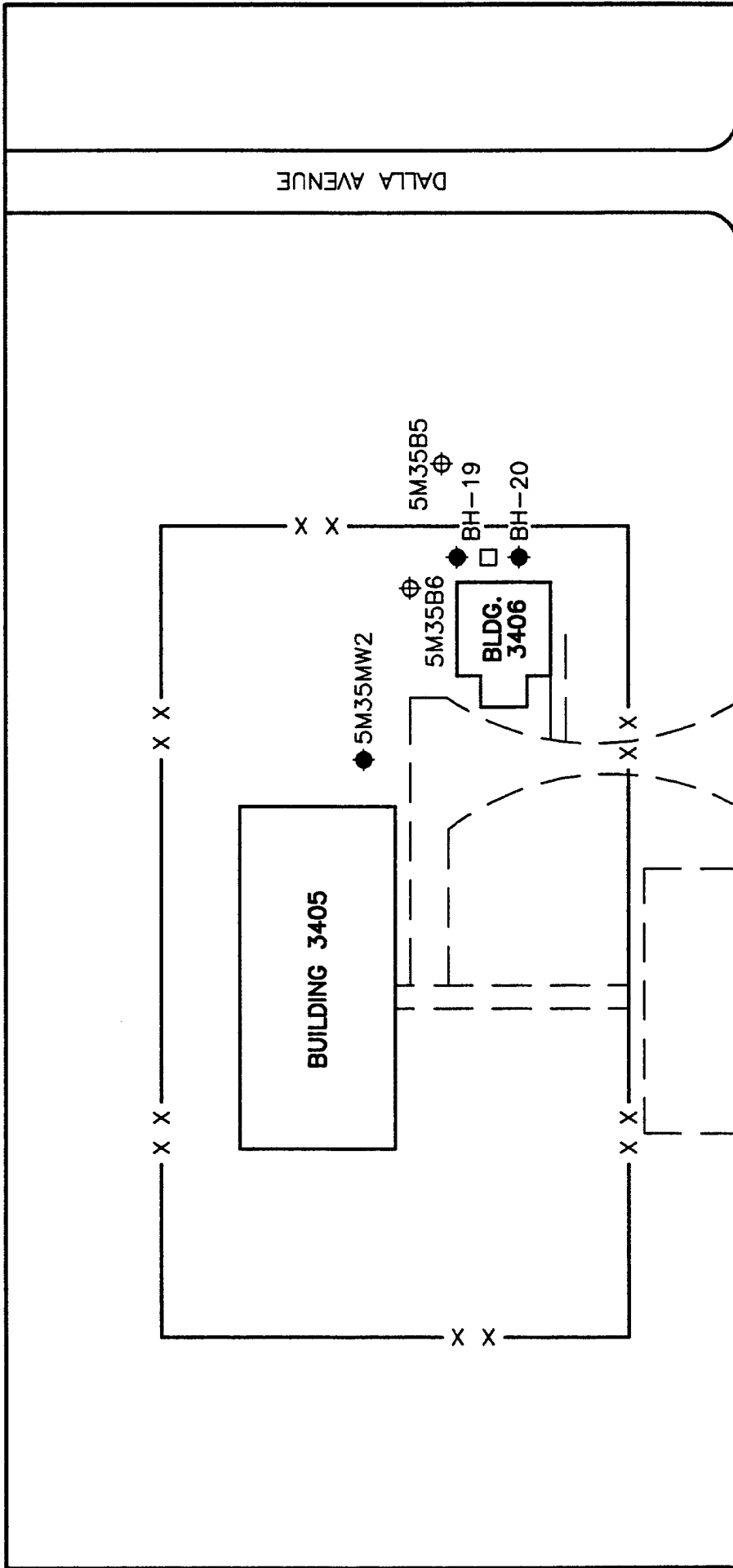

FIGURE 2.2

SITE LOCATION MAP
 IRP SITE 35C
 FORMER DIESEL UST AREA

MARCH AFB, CALIFORNIA

ENGINEERING-SCIENCE, INC.
 La Jolla, California



LEGEND

- ⊕ EXISTING BORING
- ◆ EXISTING MONITORING WELL
- FORMER 1,000 GAL. DIESEL TANK

3.1 Site Layouts

A general description of the criteria used for siting a central VW and vapor MPs is included in the protocol document (Hinchee, et al., 1992). Figures 3.1 and 3.2 illustrate the proposed locations of the central VW and MPs at each site. The final locations of the VW and MPs may vary slightly from the proposed locations if significant fuel contamination is not observed in the boring for the central VW. Based on site investigation data, the central VWs should be located near the center of former tank beds. Due to high hydrocarbon levels, it is expected that soils in these areas will be oxygen depleted (<2 percent O₂). Increased biological activity should be stimulated by oxygen-rich soil gas ventilation during pilot test operations.

It appears that soil contamination has not migrated substantially from the former tank beds. Therefore, the radius of venting influence of the VWs may be greater than the extent of the contaminated soil. The three MPs (MPA, MPB, and MPC) at each site will be located within a 20- to 30-foot radial distance from the VW in diesel-contaminated soil if possible.

A single background MP will be located in uncontaminated soils between these two sites. It will be used to measure background levels of oxygen and carbon dioxide, and to determine if natural carbon sources are contributing to oxygen uptake during the *in situ* respiration tests.

3.2 Vent Wells

VWs will be constructed from 4-inch inside-diameter (ID) Schedule 40 PVC casing and 0.04-inch slotted screen. The screened interval for the VW at Site 35a will be set at 10 to 25 feet bgs. The VW for Site 35c will be screened from 5 to 10 feet bgs. The screened interval will be extended if contamination is found below 10 feet. Flush-threaded PVC casing and screen, without organic solvents or glues, will be used. The filter pack will be clean, well-rounded silica sand with an 8-12 grain size. It will be placed in the annular space of the screened interval. A 3-foot-thick layer of bentonite pellets, hydrated in place with potable water, will be placed directly over the filter pack. This bentonite layer will prevent the Volclay® grout slurry, placed in the annulus, from saturating the filter pack. The Volclay® grout will be tremied into the annular space above the bentonite pellets to a depth of two feet bgs, thus producing an air-tight seal above the screened interval. A complete seal is critical to prevent injected air from short-circuiting to the surface during the bioventing test. The remaining two feet will be left vacant to allow possible connection of a subsurface air line for full-scale system implementation. Figures 3.3 and 3.4 illustrate the proposed VW construction for these sites.

3.3 Monitoring Points

A typical multi-depth vapor MP installation for Site 35a is shown in Figure 3.5. Oxygen, carbon dioxide and total volatile hydrocarbon concentrations in soil gas will be monitored via vapor monitoring screens placed at depth intervals of 11 to 13 feet, 16 to 18 feet, and 21 to 23 feet at each MP location, depending on actual field observations of soil type and contamination.

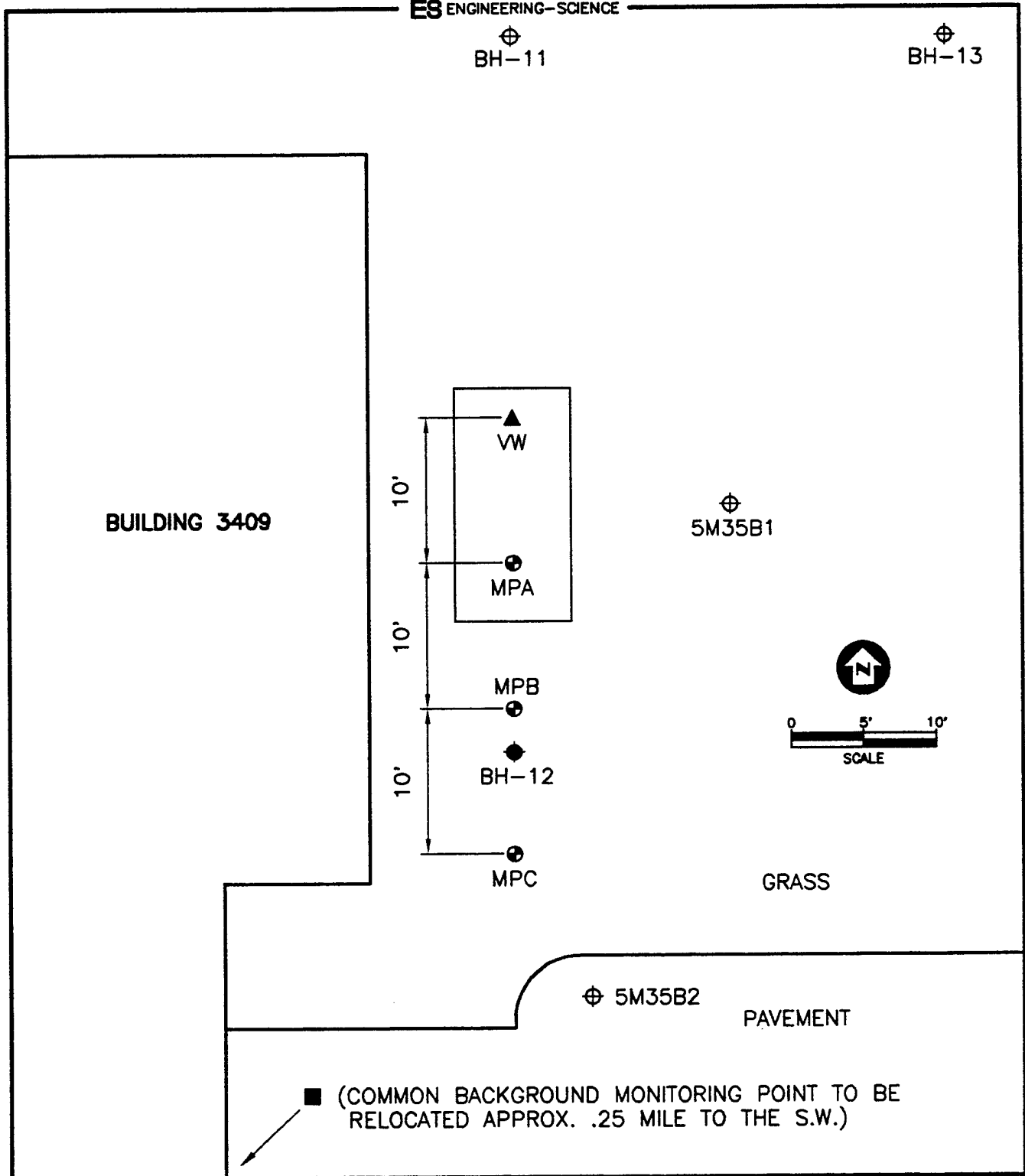

■ (COMMON BACKGROUND MONITORING POINT TO BE RELOCATED APPROX. .25 MILE TO THE S.W.)

LEGEND

- ▲ PROPOSED VENT WELL (AIR INJECTION)
- ⊕ PROPOSED VAPOR MONITORING POINT
- PROPOSED BACKGROUND MONITORING POINT
- ⊕ EXISTING BORING
- ◆ EXISTING MONITORING WELL
- FORMER DIESEL UST LOCATION

FIGURE 3.1

PROPOSED VENT WELL/VAPOR
MONITORING POINT LOCATIONS
IRP SITE 35A
FORMER DIESEL UST AREA
MARCH AFB, CALIFORNIA

ENGINEERING-SCIENCE, INC.
La Jolla, California



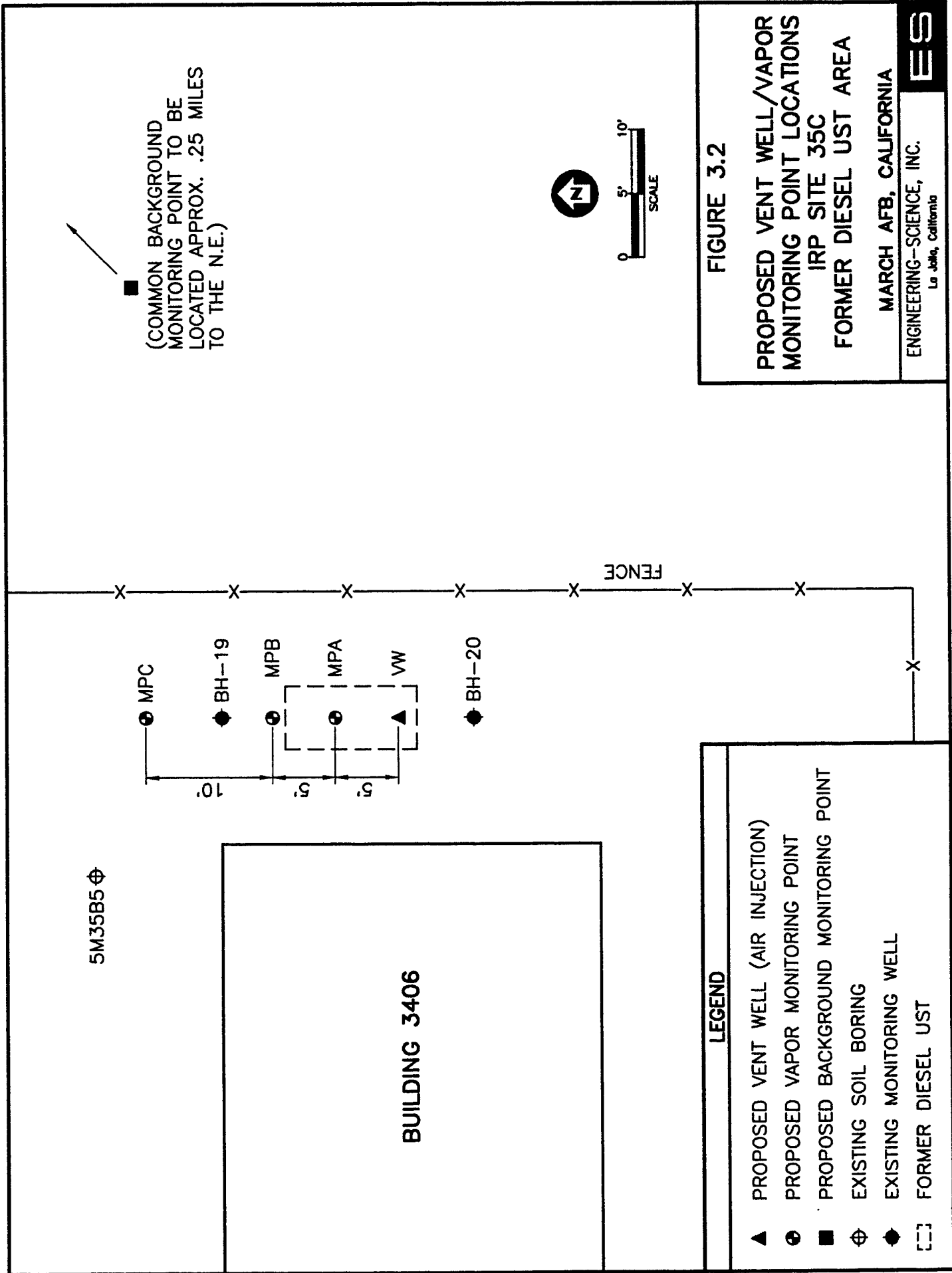

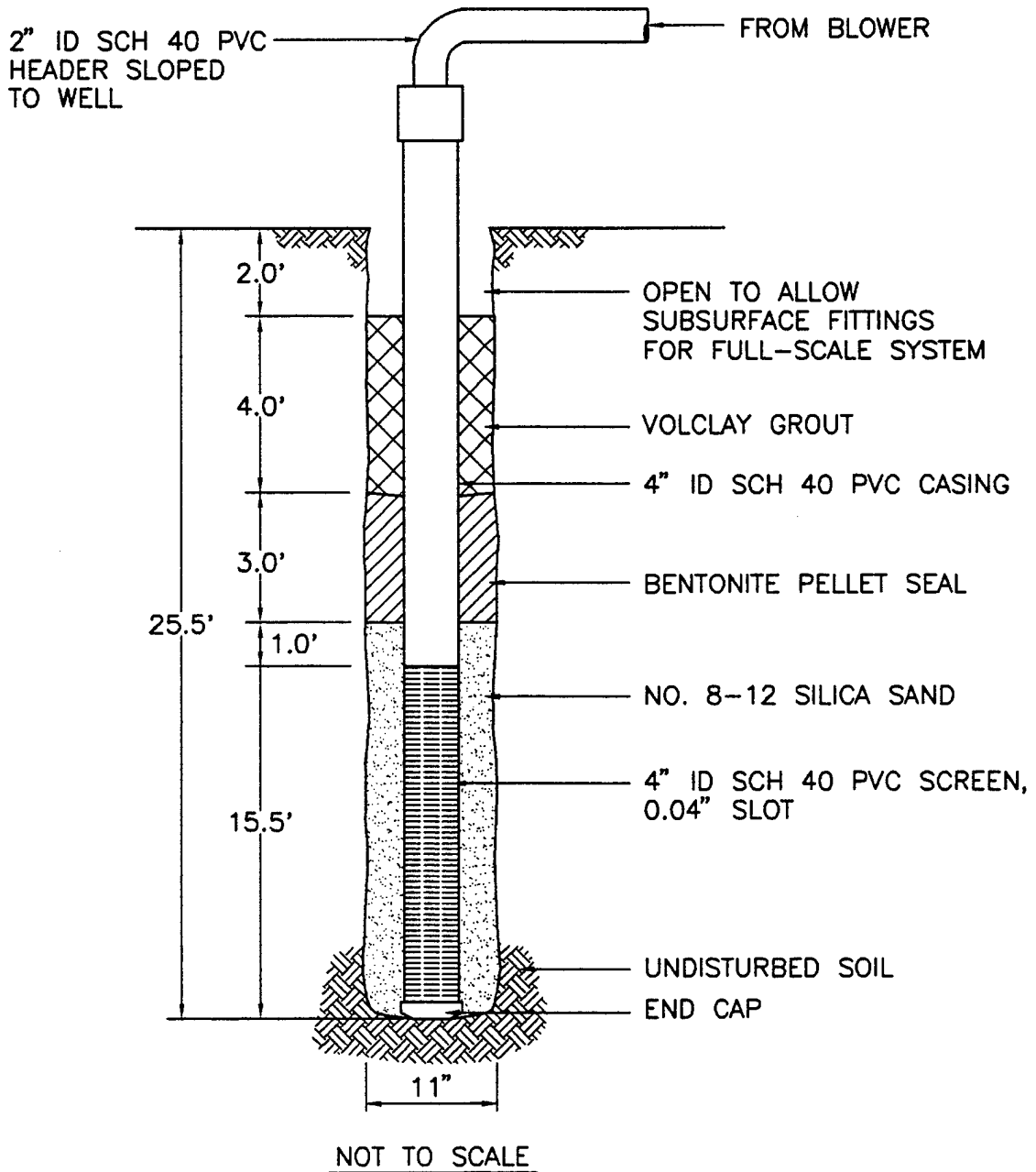

FIGURE 3.3
PROPOSED AIR INJECTION VENT
WELL CONSTRUCTION DETAILS
IRP SITE 35A
FORMER DIESEL UST AREA
MARCH AFB, CALIFORNIA
ENGINEERING-SCIENCE, INC.
 La Jolla, California



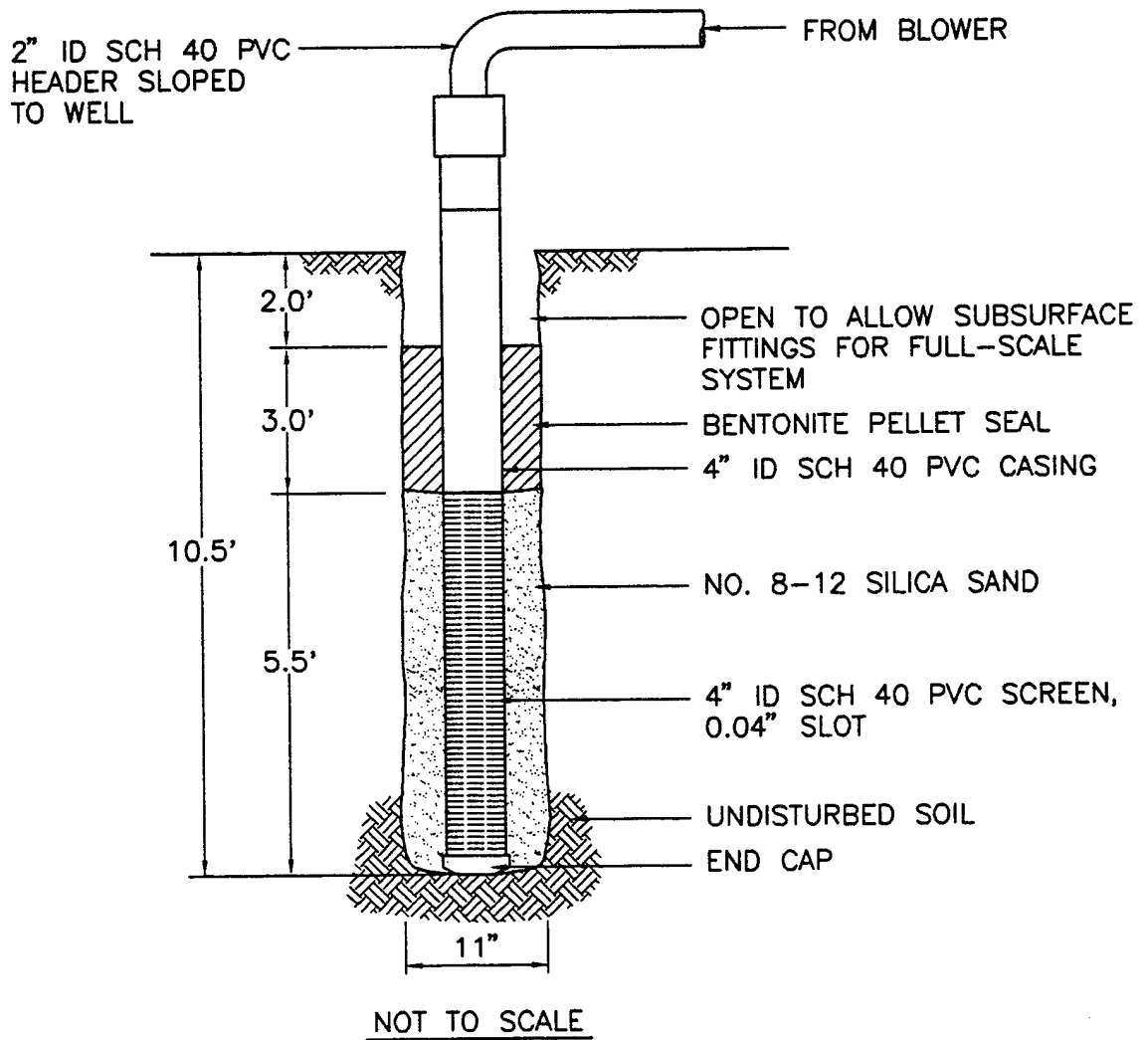

FIGURE 3.4
PROPOSED AIR INJECTION VENT
WELL CONSTRUCTION DETAILS
IRP SITE 35C
FORMER DIESEL UST AREA

MARCH AFB, CALIFORNIA

ENGINEERING-SCIENCE, INC.
 La Jolla, California

ES

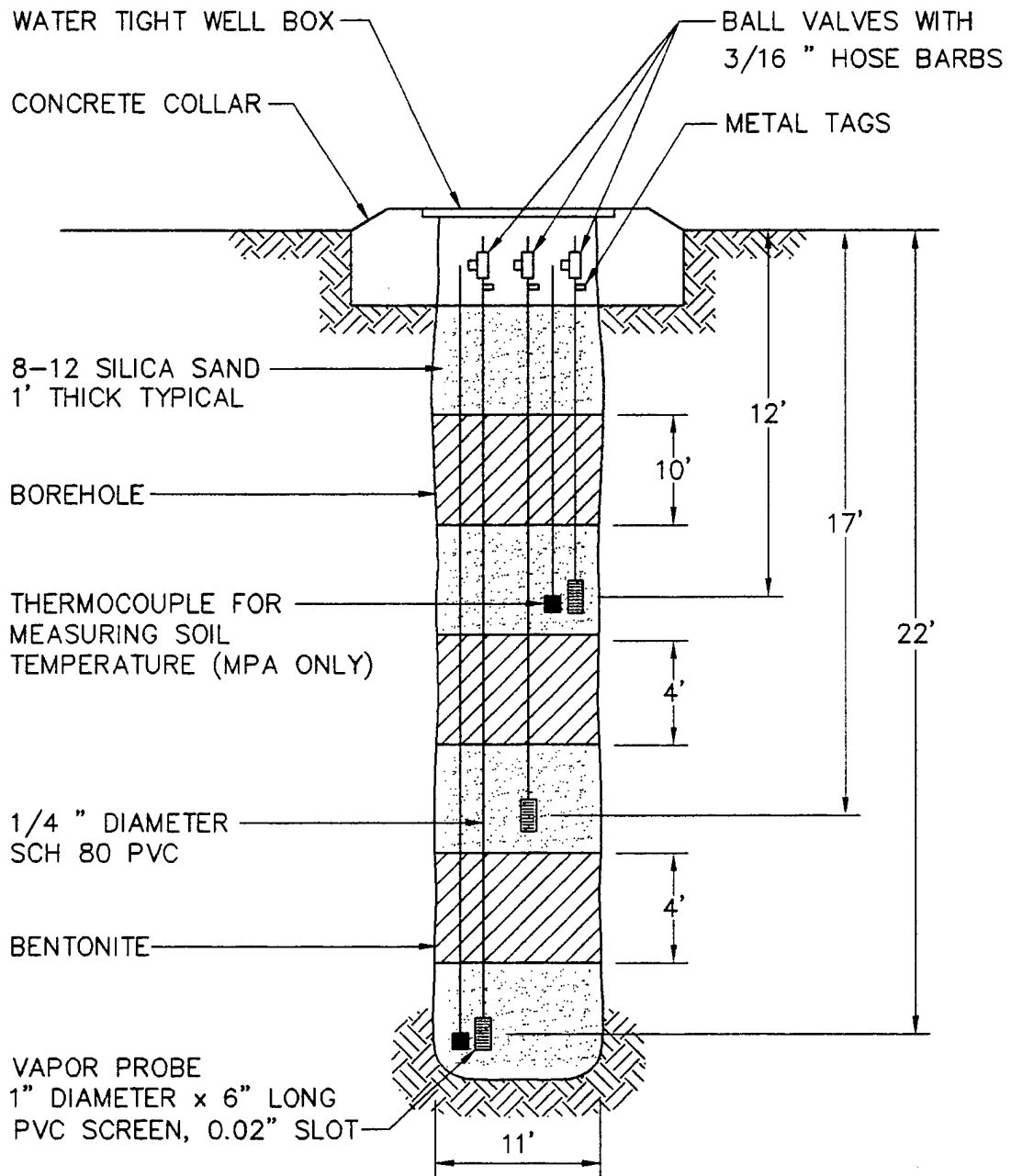

FIGURE 3.5
PROPOSED MONITORING POINT
CONSTRUCTION DETAILS
IRP SITE 35A
FORMER DIESEL UST AREA

MARCH AFB, CALIFORNIA

ENGINEERING-SCIENCE, INC.
La Jolla, California



A typical multi-depth vapor MP installation for Site 35c is shown in Figure 3.6. Oxygen, carbon dioxide, and total volatile hydrocarbon concentrations in soil gas will be monitored via vapor monitoring screens placed at depth intervals of three to five feet and eight to ten feet, depending on actual field observations of soil type and contamination. Unlike Site 35a, where soil contamination is limited to the decomposed granite, both soil and decomposed granite will be monitored at Site 35c.

Multi-depth monitoring will assess whether the entire soil profile is receiving oxygen and will be used to measure fuel biodegradation rates at all monitored depths. The annular space between the vapor monitoring screen filter packs will be sealed with bentonite to isolate the monitoring intervals. As with the central VW, several inches of bentonite pellets will be used to shield the filter pack from rapid infiltration of bentonite slurry additions. Additional details on VW and MP construction are found in Section 4.0 of the protocol document.

3.4 Handling of Drill Cuttings

Drill cuttings will be collected in U.S. Department of Transportation (DOT) approved containers. These containers will be labeled, and then placed in the March AFB hazardous materials storage area, or in another area designated by the base point-of-contact. Drill cuttings will become the responsibility of March AFB, or their designated contractor. They will be analyzed and disposed of in accordance with current procedures for ongoing remedial investigations.

3.5 Soil and Soil Gas Sampling

3.5.1 Soil Samples

A total hydrocarbon vapor analyzer (THVA) will be used during drilling to screen soil samples for determining intervals of high fuel contamination. Three soil samples will be collected from each pilot test area during the installation of the VWs and MPs. Sampling procedures will follow those outlined in the protocol document. One sample will be collected from the most contaminated interval of each VW boring. In addition, one sample will be collected from the interval of highest apparent contamination in each of the two MP borings closest to the VW at each site. Soil samples will be analyzed for Total Recoverable Petroleum Hydrocarbons (TRPH); Benzene, Toluene, Ethylbenzene, and Xylenes (BTEX); and soil moisture, pH, grain size distribution, alkalinity, total iron, and nutrients, including Total Kjeldahl Nitrogen (TKN) and total phosphorous.

An additional soil sample will be collected from representative soils in the background MP and analyzed for TKN in order to determine if useful nitrogen has been introduced into highly-contaminated soils through nitrogen-fixing soil microorganisms and, also, how nitrogen levels in contaminated soils vary from those in similar uncontaminated soils.

Samples for TRPH and BTEX analyses will be collected using a split-spoon sampler containing brass tube liners. Soil samples collected in the brass tubes for TRPH and BTEX analyses will be trimmed immediately, and the ends will be sealed with Teflon sheets held in place by plastic caps. Soil samples collected for physical parameter analyses will be placed in glass sample jars, or other appropriate sample containers, as specified in the base sample handling plan. Soil samples will

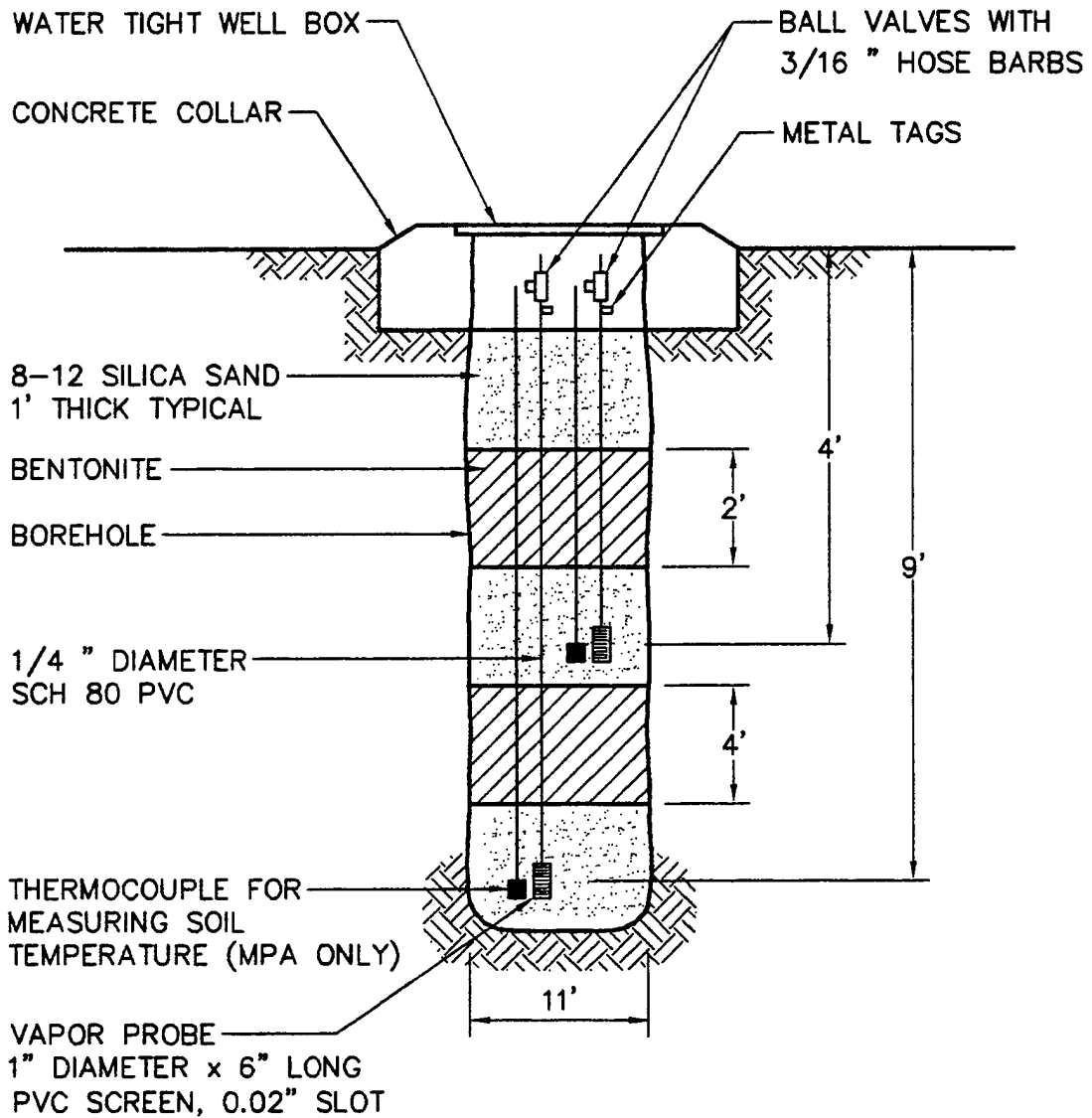

FIGURE 3.6
PROPOSED MONITORING POINT
CONSTRUCTION DETAILS
IRP SITE 35C
FORMER DIESEL UST AREA

MARCH AFB, CALIFORNIA

ENGINEERING-SCIENCE, INC.
La Jolla, California



be labelled following the nomenclature specified in Section 5.5 of the protocol document, wrapped in plastic, and placed in a cooler for shipment. A chain-of-custody form will be completed, and the cooler will be shipped to Pace Laboratory in Huntington Beach, California for analysis. This laboratory has been audited by the Air Force and meets all Quality Assurance/Quality Control (QA/QC) and certification requirements for the State of California.

3.5.2 Soil Gas Samples

During the pilot test, initial soil gas samples will be collected in SUMMA[®] canisters, in accordance with the *Bioventing Field Sampling Plan* (ES, 1992). These samples will be collected from VWs, and from the MPs closest to and furthest from the VWs (MPA and MPC). Additionally, these soil gas samples will be used to determine the reduction in BTEX and Total Volatile Hydrocarbons (TVH) during the one-year tests, and to detect any migration of these vapors from the source areas.

Soil gas sample canisters will be placed in a small cooler and packed with foam pellets to prevent excessive movement during shipment. In order to prevent condensation of hydrocarbons, samples will not be preserved on ice. A chain-of-custody form will be completed, and the cooler will be shipped to the Air Toxics, Inc., laboratory in Folsom, California, where the samples will be analyzed.

3.6 Blower Systems

At Site 35a, a portable 3-horsepower positive-displacement blower, capable of injecting air over a wide range of flow rates and pressures, will be used to conduct the initial air permeability tests. It is not certain how the VW screened over 15 feet of decomposed granite will respond to air injection. Therefore, the appropriate size blower for the extended (one-year) pilot tests will be determined from the results of the initial air permeability test. This fixed blower unit would be installed at the site as soon as possible after the initial pilot test.

A 1-horsepower regenerative blower, capable of injecting 30 standard cubic feet per minute (scfm) at 50 inches of water, will be used to conduct the initial air permeability test at Site 35c. The VW for Site 35c is screened from 5 to 10 feet bgs. This interval includes the silty sand/weathered granite contact and the uppermost weathered granite zone. Although some preferential air flow through the silty sand may occur, air flow and oxygen diffusion through the weathered granite should be sufficient to accelerate biodegradation in the weathered granite.

A schematic diagram of a typical air injection system used for pilot testing is shown on Figure 3.7. The maximum power requirement anticipated for this pilot test is 230-volt, single-phase, 30-amp service. Additional power supply requirement details are described in Section 5.0, Base Support Requirements.

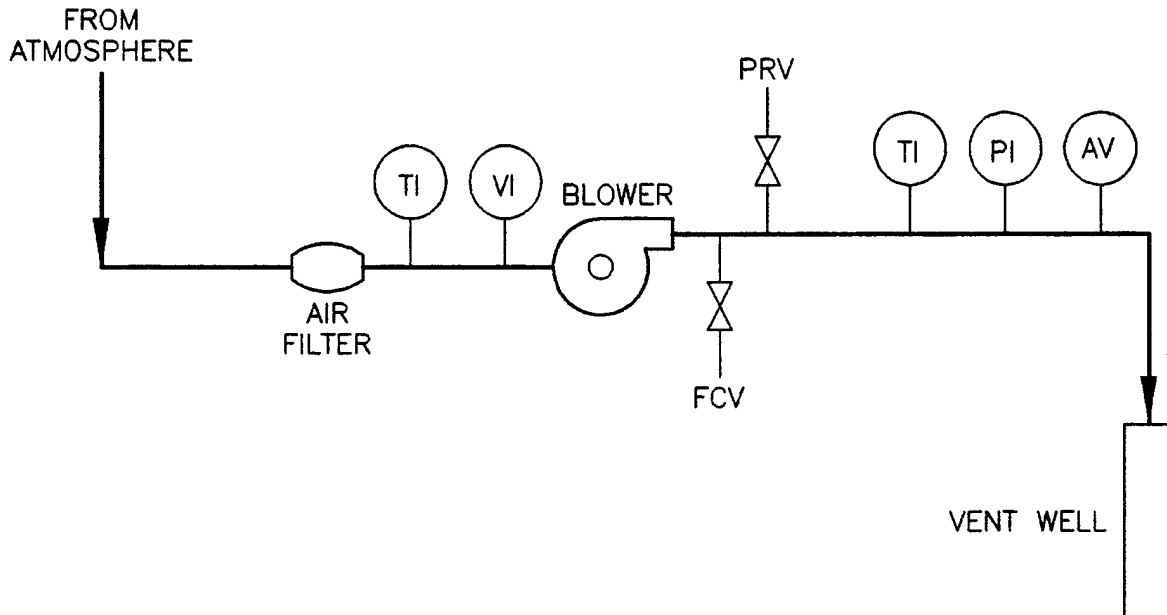

LEGEND

- (AV) AIR VELOCITY PORT
- (PI) PRESSURE INDICATOR
- (TI) TEMPERATURE INDICATOR
- (VI) VACUUM INDICATOR
- FCV FLOW CONTROL VALVE
- PRV PRESSURE RELIEF VALVE

FIGURE 3.7
 BLOWER SYSTEM
 INSTRUMENTATION DIAGRAM
 FOR AIR INJECTION
 IRP SITES 35A AND 35C
 FORMER DIESEL UST AREAS
 MARCH AFB, CALIFORNIA

ENGINEERING-SCIENCE, INC.
 La Jolla, California



3.7 In situ Respiration Tests

The objective of *in situ* respiration tests is to determine the rate at which soil bacteria degrade petroleum hydrocarbons in the presence of oxygen. Respiration tests will be performed at each site in selected MPs, where bacterial biodegradation of hydrocarbons is indicated by low oxygen levels and elevated carbon dioxide concentrations in the soil gas. A 1 scfm pump will inject air into the selected MP depth intervals containing low oxygen levels (<2%). A 20-hour air injection period will be used to oxygenate local contaminated soils. At the end of the 20-hour air injection period, the air supply will be cut off, and oxygen and carbon dioxide levels will be monitored for the following 48 to 72 hours. The decline in oxygen concentrations and increase in carbon dioxide concentrations over time will be used to estimate rates of bacterial degradation of fuel residuals. Helium, an inert gas, will be injected at a concentration of two to four percent into every MP that is being used for respiration testing. The helium will be used as a tracer gas and levels will be monitored during the respiration test to identify possible system leaks or short circuits to the surface. Additional details on the *in situ* respiration test are found in Section 5.7 of the protocol document.

3.8 Air Permeability Test

The objective of air permeability tests is to determine the areal extent of the subsurface soil (radius of influence) that can be oxygenated using one air injection VW. Air will be injected into the 4-inch-diameter VW using the portable blower unit. Pressure response will be measured at each MP with differential pressure gauges to determine the region influenced by the unit. Oxygen will also be monitored in the MPs to verify that oxygen levels in the soil increase as the result of air injection. One air permeability test, lasting 4 to 8 hours, will be performed at each site.

3.9 Air Emission Monitoring

Soil gas will not be extracted from the site during either the initial or extended pilot test. The proposed bioventing system will use a low rate (<30 scfm) of air injection to provide oxygen for enhanced biodegradation. Because these soils are contaminated with relatively small quantities of low-volatility diesel oil, the potential for volatile emissions is very low. Because horizontal permeability is generally greater than vertical permeability, injected air has a tendency to move outward rather than upward. This will promote *in situ* biodegradation of fuel vapor as it moves slowly outward from the center of the spill.

If some upward movement of injected air does occur, it will be highest during the first day of air injection when the initial soil gas volume is displaced. ES will carefully monitor air in the breathing zone during the first day of testing. A photoionization detector (PID) will be used to detect any emissions exceeding ambient conditions. The PID will be calibrated with benzene to detect BTEX compounds at the 1 part per million by volume (ppmv) level. This level of detection is consistent with the most conservative OSHA standards. Any sustained BTEX reading in excess of 1 ppmv will require an immediate reduction in air injection rates.

3.10 Installation of Extended (One-Year) Pilot Test Bioventing System

Extended (one-year) bioventing pilot test systems will be installed at Sites 35a and 35c if the initial pilot tests successfully demonstrate the feasibility of providing oxygen throughout the contaminated soil profile. Continued air injection would determine the long-term radius of oxygen influence, and the effects of time, available nutrients, and changing temperatures on fuel biodegradation rates. A fixed blower unit will be installed at each site as part of the extended pilot test system, and will be housed in a small, prefabricated shed to provide protection from the weather and to minimize noise. Systems will be operated for one year. Every six months, ES personnel will conduct *in situ* respiration tests to monitor the long-term performance of the bioventing systems. In addition, subsurface soil samples will be collected after one year at locations as close as possible to the original MP/VW soil sample locations in order to assess the degree of remediation achieved during the first year of *in situ* treatment. Weekly system checks will be performed by March AFB personnel. If required, major maintenance of the blower unit will be performed by ES Pasadena or San Diego personnel. Detailed blower system information and a maintenance schedule will be included in the operation and maintenance (O&M) manual provided to the base. More detailed information regarding the test procedures are included in the protocol document.

4.0 EXCEPTIONS TO PROTOCOL PROCEDURES

Procedures used to construct MPs and VWs, and to measure soil permeability to air and *in situ* respiration rates, are described in Sections 4.0 and 5.0, respectively, of the protocol document (Hinchee et al., 1992). No exceptions to the protocol are anticipated.

5.0 BASE SUPPORT REQUIREMENTS

The following base support is needed prior to arrival of the drilling subcontractor and the ES pilot test team:

- Coordination of this work plan with local regulatory agencies and advising if any additional permits or information are required.
- Obtaining a base excavation permit.
- Confirmation of an available power source, including a 230-volt, 30-amp, single-phase breaker box with one 230-volt receptacle and two 110-volt receptacles located within 50 feet of the VWs at each site.
- Provision of any paperwork required to obtain gate passes and security badges for approximately three ES employees, two drillers, and an electrician (if a base electrician is not available). Vehicle passes will be needed for one truck and trailer, and a drill rig.
- Provision of keys to the on-site groundwater monitoring wells.

During initial testing, the following base support is needed:

- Twelve square feet of desk space and a telephone in a building located as close to the site as practical.
- The use of a facsimile machine for transmitting 15 to 20 pages of test results.

- A decontamination pad where the driller can clean augers between borings.
- Acceptance of responsibility for drill cuttings and decontamination water from VW and MP borings, including any drum sampling to determine hazardous waste status. (If ES transfers custody of drums to another contractor working on the base, assistance in arranging this transfer will also be needed.)

During the one-year extended pilot tests, base personnel will be required to perform the following activities:

- Check the blower system once per week to ensure that it is operating and to record the air injection pressure and temperature. ES will provide a brief training session for this procedure and a maintenance procedures manual with data collection sheets.
- If the blower stops working, notify: Mr. Larry Dudus of ES San Diego at (619) 453-9650, Mr. Chris Pluhar of ES Pasadena at (818) 585-6324, or Mr. Jerry Hansen of AFCEE at (512) 536-4331.
- Arrange site access for an ES technician to conduct *in situ* respiration tests approximately six months and one year after the initial pilot test.

6.0 PROJECT SCHEDULE

The following schedule is contingent upon approval of this pilot test work plan and completion of base support requirements.

Event	Date
Draft Pilot Test Work Plan to AFCEE/March AFB	March 8, 1993
Begin Initial Pilot Test	March 15, 1994
Interim Results Report	July 1994
6 Month Respiration Test	September 1994
Final Respiration Test and Soil Sampling	March 1995

7.0 POINTS OF CONTACT

Dr. John Sabol
 22 SPT 9/DEV
 Bldg 768 W
 March AFB, CA 92518-5000
 (714) 655-2477

Lt. Col. Ross Miller/Mr. Jerry Hansen
AFCEE/EST
Brooks AFB, TX 78235-5000
(512) 536-4331

Mr. Larry Dudus
Engineering-Science, Inc.
9404 Genesee Ave., Suite 140
La Jolla, CA 92037
(619) 453-9650
FAX (619) 453-9652

Mr. Doug Downey
Engineering-Science, Inc.
1700 Broadway, Suite 900
Denver, CO 80290
(303) 831-8100
FAX (303) 831-8208

8.0 REFERENCES

Engineering-Science, Inc. 1992. *Field Sampling Plan for AFCEE Bioventing*.
Denver, Colorado.

Hinchee, R.E., Ong, S.K., Miller, R.N., Downey, D.C., Frandt, R., 1992. *Test Plan and Technical Protocol for a Field Treatability Test for Bioventing*. January.

TetraTech, Inc. 1992. *Final Installation Restoration Program (IRP) Stage 5 Work Plan Addendum Operable Unit No. 2 Sites March Air Force Base, California*. August.

TetraTech, Inc. 1993. Preliminary Analytical Results and Draft Boring Logs, Site 35a and Site 35c. (Information not completely quality checked or validated.)

Engineering-Science, Inc. 1988. *Installation Restoration Program Phase II - Confirmation Quantification Stage 2*. June.

CONTENTS

PART II

DRAFT BIOVENTING PILOT TEST INTERIM TEST RESULTS REPORT FORMER DIESEL UST AREA INSTALLATION RESTORATION PROGRAM, SITE 35c MARCH AFB, CALIFORNIA

	Page
1.0 INTRODUCTION	II-1
2.0 IRP SITE 35C	II-1
2.1 Pilot Test Design and Construction	II-1
2.1.1 Air Injection Vent Well	II-5
2.1.2 Monitoring Points	II-5
2.1.3 Blower Unit	II-5
2.2 Soil and Soil Gas Sampling Results	II-9
2.2.1 Soil Sampling Results	II-9
2.2.2 Soil Gas Sampling Results	II-9
2.3 Pilot Test Results	II-12
2.3.1 Exceptions to Test Protocol Procedures	II-12
2.3.2 Initial Soil Gas Chemistry	II-12
2.3.3 In Situ Respiration Rates	II-12
2.3.4 Air Permeability	II-16
2.3.5 Oxygen Influence	II-16
2.3.6 Potential Air Emissions	II-16
2.4 Recommendations	II-18
3.0 REFERENCES	II-19
APPENDIX A O&M MANUAL	
APPENDIX B GEOLOGIC BORING LOGS AND CHAIN-OF-CUSTODY FORMS	

FIGURES

Figure	Description	Page
1.1	Record Drawing, Soil Boring Locations, IRP Site 35a Former Diesel UST Area	II-2
2.1	Record Drawing Vent Well/Monitoring Point Locations, IRP Site 35c Former Diesel UST Area	II-3
2.2	Geologic Cross Section A-A, IRP Site 35c Former UST Area	II-4
2.3	Record Drawing Air Injection Vent Well Construction Details, IRP Site 35c Former Diesel UST Area	II-6
2.4	Record Drawing Monitor Point Construction Details, IRP Site 35c Former Diesel UST Area	II-7
2.5	Record Drawing Blower System Instrumentation Diagram for Air Injection, IRP Site 35c Former Diesel UST Area	II-8
2.6	Respiration Test MA1-MPB-7 IRP Site 35c	II-14
2.7	Respiration Test MA1-MPB-10 IRP Site 35c	II-15

TABLES

Table	Description	Page
2.1	Soil and Soil Gas Laboratory and Analytical Results IRP Site 35c	II-10
2.2	Initial Soil Gas Chemistry IRP Site 35c	II-13
2.3	Oxygen Utilization Rates IRP Site 35c	II-16
2.4	Pressure Response During Air Permeability Test IRP Site 35c	II-17
2.5	Influence of Air Injection Vent Well on Monitoring Point Oxygen Levels IRP Site 35c	II-18

PART II

DRAFT

BIOVENTING PILOT TEST INTERIM RESULTS REPORT FORMER DIESEL UST AREA INSTALLATION RESTORATION PROGRAM, SITE 35c MARCH AFB, CALIFORNIA

1.0 INTRODUCTION

The purpose of this Part II report is to describe the results of the initial pilot test at IRP Site 35c and to make specific recommendations for extended testing which will determine the long-term impact of bioventing on site contamination. A description of the site history and contaminants detected during previous investigations is described in Part I, the Bioventing Pilot Test Work Plan.

Part I of this report describes a pilot test which was planned at IRP Site 35a, another former diesel UST site. However, after drilling five soil borings through the former tank bed, adjacent to former product pipe lines, and next to previously drilled investigation borings in which up to 4,640 mg/kg of TPH as diesel had been detected, insufficient contamination was encountered to justify conducting a pilot test at this site. Figure 1.1 shows the location of the soil borings. These borings were drilled to depths ranging from 14 to 19 feet below ground surface (bgs). Groundwater was encountered at approximately 18 feet bgs. At most, some samples exhibited only a very slight petroleum odor; there was no visible soil staining and only low field OVA readings. Boring logs for this site are contained in Appendix B.

2.0 IRP SITE 35c

2.1 Pilot Test Design and Construction

Installation of an air injection vent well (VW) and three vapor monitoring points (MPs) at the IRP site (designated MA1) was completed on March 15, 1994. Drilling services were provided by Tonto Environmental Drilling of Fontana, California. Well installation and soil sampling were directed by Engineering-Science, Inc. (ES), geologists Mr. Larry Dudus and Mr. Kyle Caskey. The following sections describe the design and installation of the bioventing pilot test system at this site.

One VW (MA1-VW), three MPs (MA1-MPA, MA1-MPB, and MA1-MPC), and a blower unit were installed at the site. Figures 2.1 and 2.2, respectively, depict the location of, and a hydrogeologic cross section for, the VW and MPs completed at

⊕
BH-13

⊕
BH-11

DEPRESSION FROM
FORMER TANK PIT

BUILDING 3409

⊕
5M35B1 --- REMOTE
FILL LINE

PRODUCT PIPING IN
BUILDING FLOOR
LEADING TO
FURNACE

■ SB4

■ SB1



■ SB3

◆ BH-12

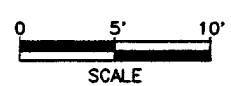

UNDERGROUND HIGH VOLTAGE LINE
GRASS

TRANSFORMER

■ SB5

⊕ 5M35B2 ■ SB2

PAVEMENT

LEGEND

- SOIL BORING
- ⊕ EXISTING BORING
- ◆ EXISTING MONITORING WELL

FIGURE 1.1

RECORD DRAWING
SOIL BORING LOCATIONS
IRP SITE 35A
FORMER DIESEL UST AREA

MARCH AFB, CALIFORNIA

ENGINEERING-SCIENCE, INC.
La Jolla, California



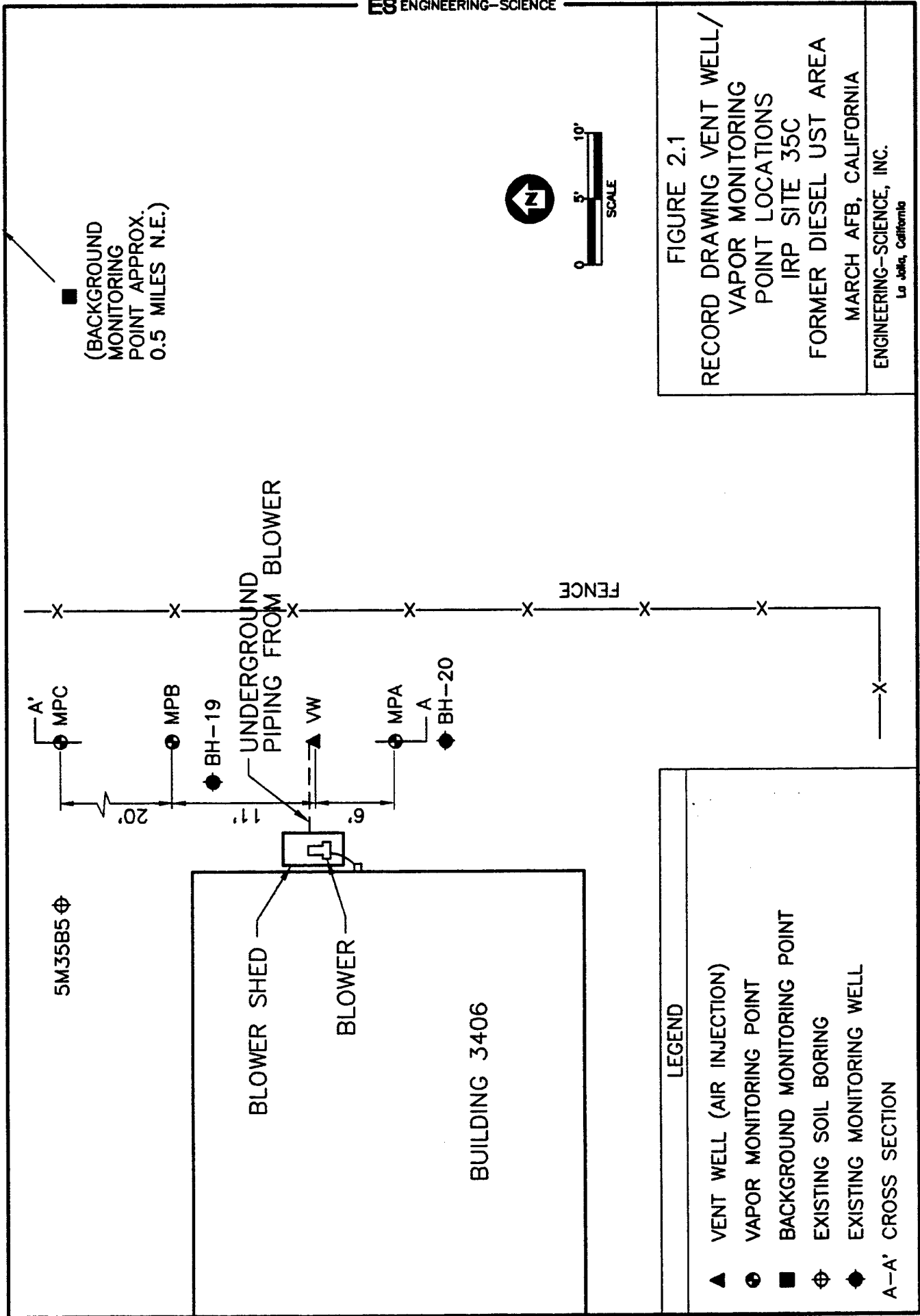

FIGURE 2.1
**RECORD DRAWING VENT WELL/
 VAPOR MONITORING
 POINT LOCATIONS
 IRP SITE 35C
 FORMER DIESEL UST AREA**
 MARCH AFB, CALIFORNIA
 ENGINEERING-SCIENCE, INC.
 La Jolla, California

LEGEND	
▲	VENT WELL (AIR INJECTION)
⊕	VAPOR MONITORING POINT
■	BACKGROUND MONITORING POINT
⊕	EXISTING SOIL BORING
◆	EXISTING MONITORING WELL
A-A'	CROSS SECTION

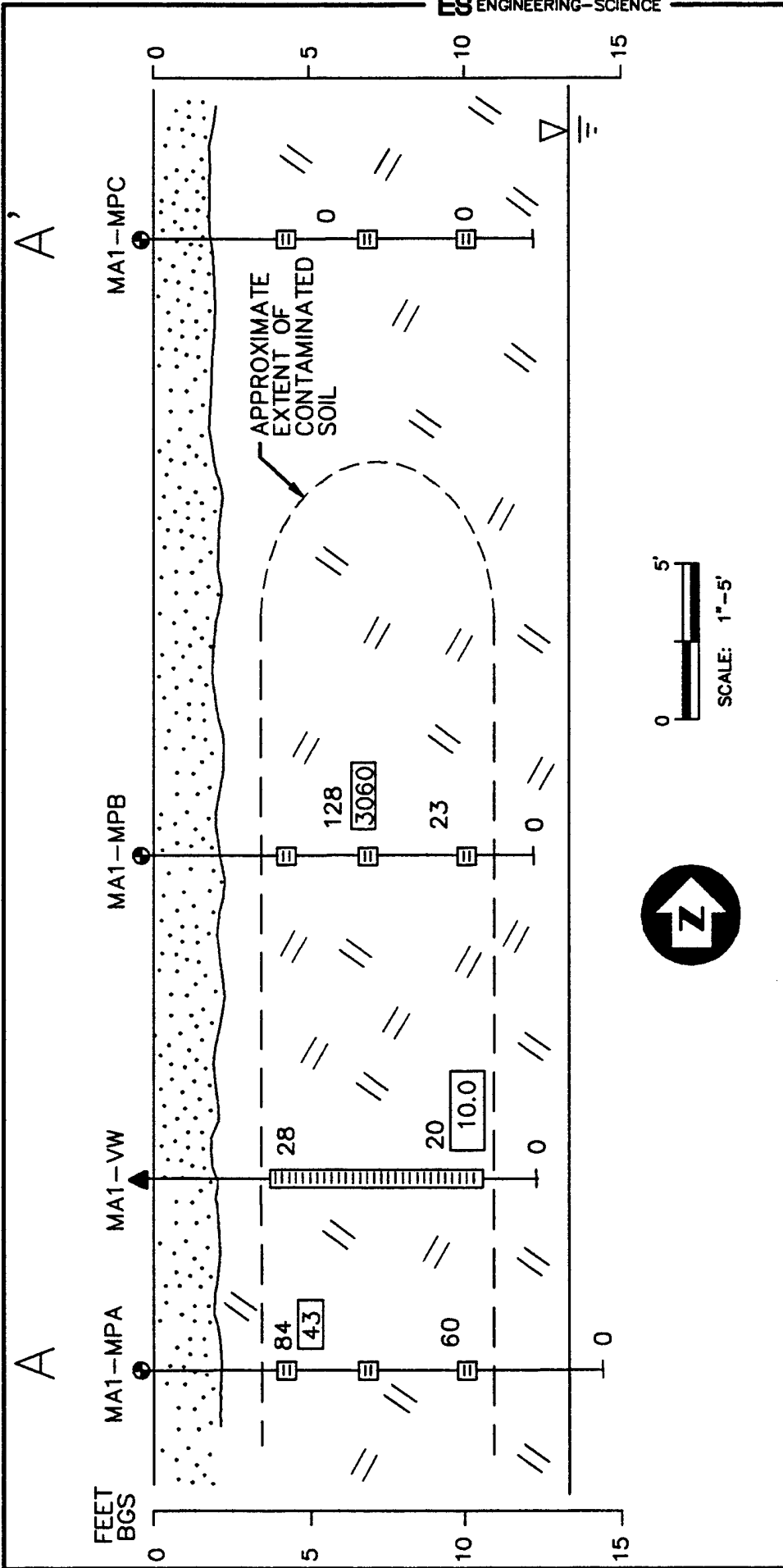

FIGURE 2.2
GEOLOGICAL CROSS SECTION
A-A'
IRP SITE 35C
FORMER DIESEL UST AREA

MARCH AFB, CALIFORNIA
 ENGINEERING-SCIENCE, INC.
 La Jolla, California

ES

LEGEND

- 123 FIELD OVA READINGS (PPMV)
- SAND
- DECOMPOSED GRANITE
- MONITORING POINT SCREEN INTERVAL
- LABORATORY RESULTS FOR TOTAL RECOVERABLE HYDROCARBONS BY EPA 418.1 (mg/kg)
- VENT WELL SCREENED INTERNAL

the site. A background MP was installed approximately 0.5 miles northeast of the site in an empty field.

2.1.1 Air Injection Vent Well

The air injection VW was installed following procedures described in the Air Force Center for Environmental Excellence (AFCEE) bioventing protocol document (Hinchee et al., 1992). Figure 2.3 shows construction details for MA1-VW.

The VW was installed through the former tank bed in hydrocarbon-contaminated soil. The VW was constructed using 4-inch diameter, Schedule 40 polyvinyl chloride (PVC) casing, with 7 feet of 0.04 inch slotted PVC screen installed from 4 to 11 feet bgs. The annular space between the well casing and borehole was filled with 4 x 12 silica sand from 11 feet bgs to the top of the well screen. Approximately 3.5 feet of bentonite pellets were placed above the sand and hydrated in place. The top of the well screen was completed with a flush mounted metal well vault set in a 2.5 x 2.5 x .5 foot concrete pad. The well casing was finished with a 4 inch by 2 inch PVC T fitting.

The fitting was attached to a 2-inch diameter Schedule 40 PVC pipe. Inside the well vault, a PVC ball valve was installed in the 2-inch pipe just after the T fitting. A small valved sampling port was installed between the ball valve and the well head. The 2-inch PVC pipe runs underground for approximately 12 feet to the blower shed. The PVC pipe is connected to a galvanized steel pipe at the blower with a rubber Fernco® connector.

2.1.2 Monitoring Points

The MP screens were installed at 4, 7, and 10 foot depths. The three MPs were constructed as shown in Figures 2.2 and 2.4. Each MP monitoring interval was constructed using a 6 inch section of 1 inch diameter 0.02 inch slotted PVC well screen and a 0.25 inch diameter Schedule 80 PVC riser pipe extending to the ground surface. At the top of each riser, a ball valve and a 3/16 inch hose barb were installed. The top of each MP was completed with a flush-mounted metal well vault set in a concrete base. Thermocouples were installed at the 4 and 10 foot depths at MA1-MPB to measure soil temperature.

2.1.3 Blower Unit

A low-flow, 1-horsepower Gast® rotary vane blower unit was used for both the initial and the extended pilot tests. For the extended pilot test, the blower was installed in a small shed located 12 feet west of MA1-VW, against Building 3406. The fixed unit is energized by a 120 volt, single-phase, 20 amp power line from a breaker box in Building 3406. The configuration, instrumentation, and specification for this blower system are shown on Figure 2.5. The blower is currently injecting air at a flow rate of approximately 12.5 cubic feet per minute (cfm) for the extended pilot test. After blower installation and start-up, ES engineers provided an operation and maintenance (O&M) manual, including maintenance instructions, equipment specifications, and monitoring forms, to base personnel. A copy of the O&M manual is provided in Appendix A.

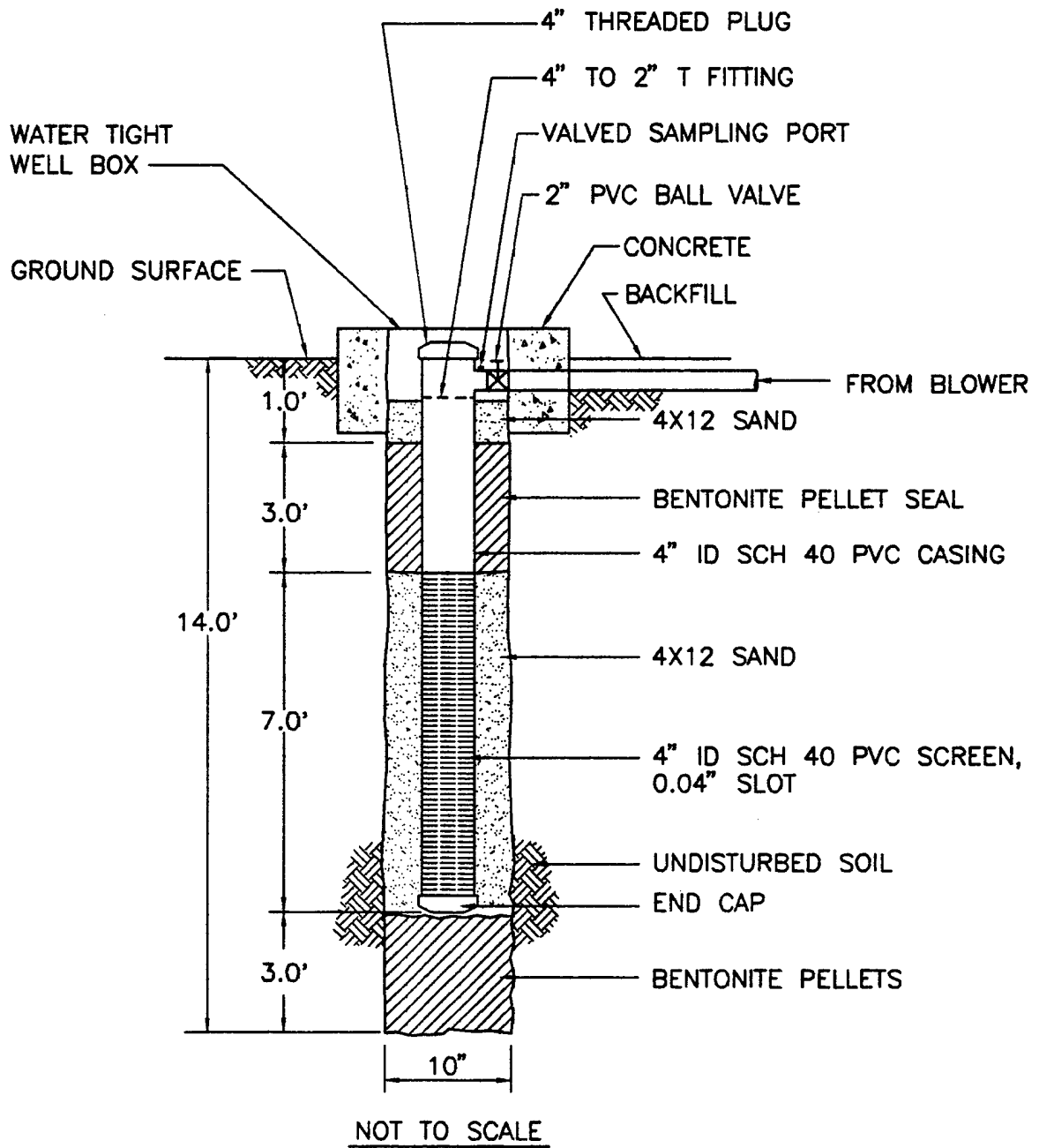

FIGURE 2.3
 RECORD DRAWING
 AIR INJECTION VENT WELL
 CONSTRUCTION DETAILS
 IRP SITE 35C
 FORMER DIESEL UST AREA
 MARCH AFB, CALIFORNIA

ENGINEERING-SCIENCE, INC.
 La Jolla, California



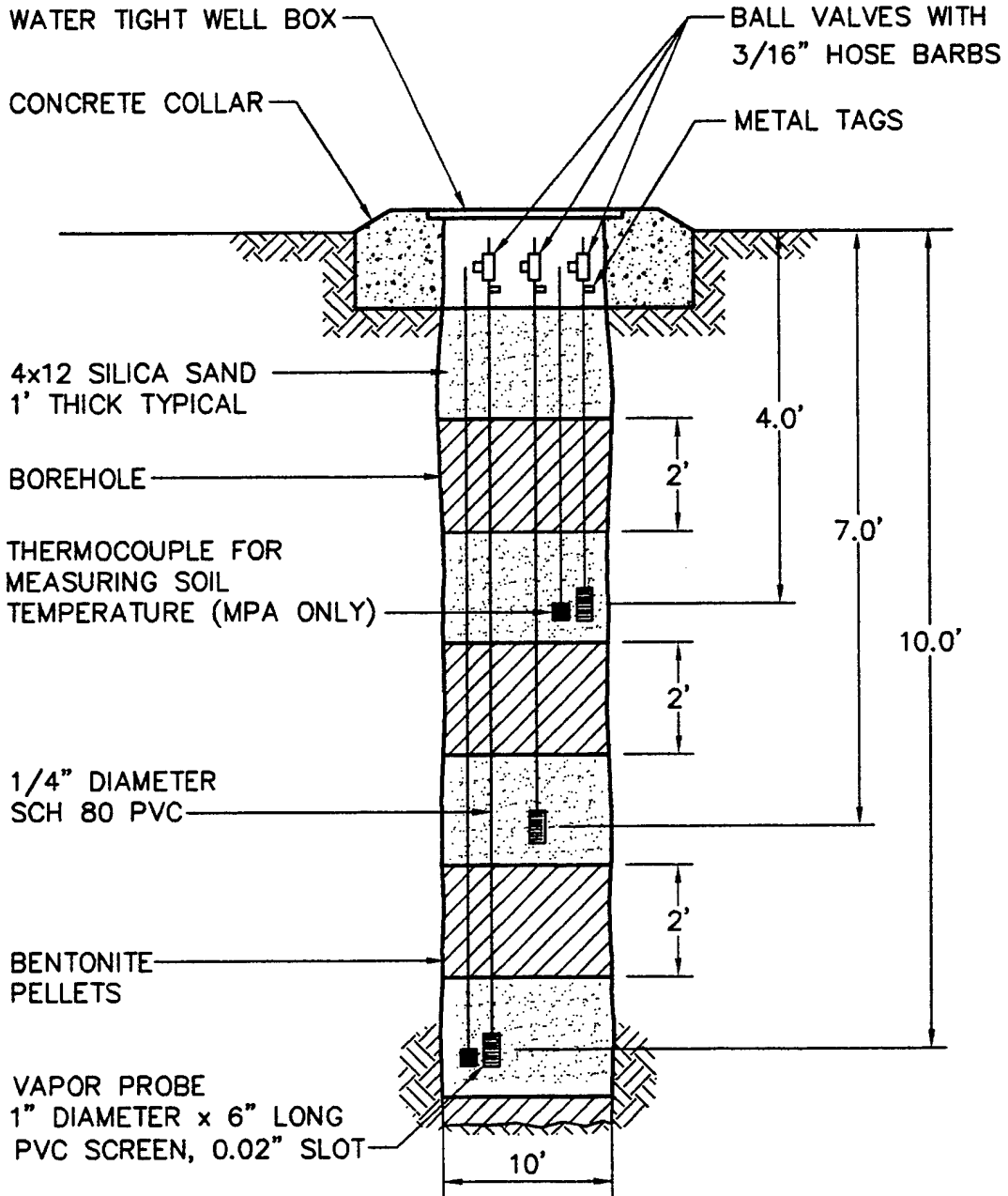
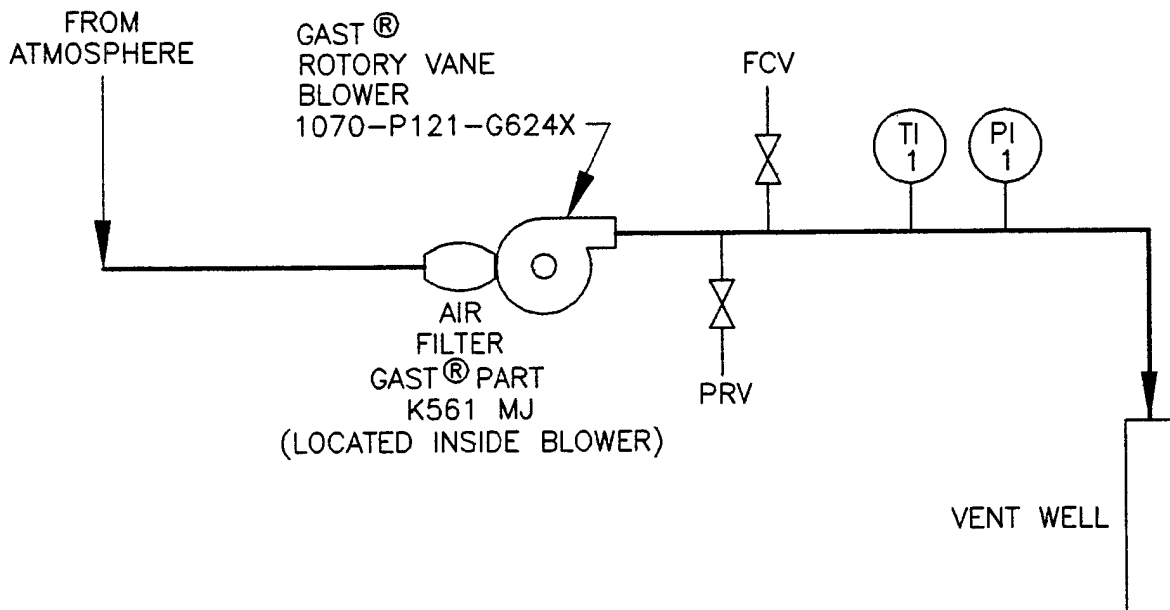

FIGURE 2.4
 RECORD DRAWING
 MONITORING POINT
 CONSTRUCTION DETAILS
 IRP SITE 35C
 FORMER DIESEL UST AREA
 MARCH AFB, CALIFORNIA

ENGINEERING-SCIENCE, INC.
 La Jolla, California





LEGEND

- PRESSURE INDICATOR 0-30 PSI GAST #AA644B
- TEMPERATURE INDICATOR 0°-250° ASHCROFT® #30E1 60R 025
- FCV FLOW CONTROL VALVE 1-1/2" BRASS BALL VALVE
- PRV PRESSURE RELIEF VALVE GAST #AA307

FIGURE 2.5
 RECORD DRAWING
 BLOWER SYSTEM
 INSTRUMENTATION DIAGRAM
 FOR AIR INJECTION
 IRP SITE 35C
 FORMER DIESEL UST AREA
 MARCH AFB, CALIFORNIA

ENGINEERING-SCIENCE, INC.
 La Jolla, California



2.2 Soil and Soil Gas Sampling Results

2.2.1 Soil Sampling Results

Soils at the site consisted of a thin veneer of coarse sand approximately 2 to 2.5 feet thick. Decomposed granite was encountered below the sand. The granite was composed predominantly of light gray to gray feldspar, abundant biotite and minor amounts of quartz. All samples were very friable. More detailed hydrogeologic information regarding the site can be found in the hydrogeologic cross section (Figure 2.2) and the geologic boring logs (Appendix B).

The VW and MPs were to be located in the former diesel tank bed, based on site background information. However, none of the borings intercepted tank bed backfill material. The exact location of the former tank bed could not be determined by site conditions.

Soil samples for laboratory analysis were collected using 18 inch split-spoon samplers with 2-inch diameter brass liners. Due to the dense, hard, nature of the decomposed granite, it was difficult to collect more than one or two brass liners full of sample for each sampling interval. As a result, samples were collected from numerous depths from each boring in order to get a sufficient sample volume for all analyses.

Soil samples were shipped via Federal Express® to Pace laboratory in Huntington Beach, California, for chemical and physical analysis. Soil samples were analyzed for Total Recoverable Petroleum Hydrocarbons (TRPH); Benzene, Toluene, Ethylbenzene and Xylenes (BTEX); iron; alkalinity; phosphates; ph; Total Kjeldahl Nitrogen (TKN); moisture content; and grain-size distribution. The results of these analyses are provided in Table 2.1. Chain-of-custody forms are provided in Appendix B.

Despite not being located in the former tank bed, MA1-VW, MA1-MPA and MA1-MPB encountered hydrocarbon-contaminated soil from approximately four feet to ten feet bgs. Based on field evidence and analytical results, soil contamination appeared highest approximately six feet bgs. TRPH concentrations ranged from 10 mg/kg at nine feet bgs in MA1-VW to 3060 mg/kg at six feet bgs in MA1-MPB. The boring for MA1-MPC appeared to be outside the zone of contamination. The boring for MA1-MPA was drilled to 14 feet bgs. Groundwater was encountered at 13.5 feet bgs. The remaining borings were drilled to 12 feet bgs. No signs of contamination were detected below ten feet bgs.

2.2.2 Soil Gas Sampling Results

Soil gas samples were collected from MA1-VW, MA1-MPB-7 and MA1-MPC-4 using 3-liter Tedlar® bags and a vacuum chamber. After the samples were collected in the Tedlar® bags, they were transferred to 1-liter SUMMA® canisters and shipped to the laboratory.

Soil gas samples were shipped via Federal Express® to Air Toxics, Inc., in Folsom, California for Total Volatile Hydrocarbons (TVH) and BTEX. The TVH analyses were referenced to jet fuel (Molecular Weight = 156) as there is no suitable analysis for the volatile fraction of diesel. The results of these analyses are provided in Table 2.1. Chain-of-custody forms are provided in Appendix B TVH

Table 2.1

Soil and Soil Gas Laboratory Analytical Results
 IRP Site 35c
 March AFB, California

Analyte (Units) ^a	Sample Location - Depth (Feet Below Ground Surface)									
	MA1-VW	MA1-MPB-7	MA1-MPC-4	MA1-VW-9	MA1-MPA-4	MA1-MPA-9	MA1-MPB-6	MA1-MPB-9	MA1-MPC-6	MA1-MPC-6
Soil Gas Hydrocarbons										
TVH ^b (ppmv)	8.5	290	110	10	43	NA	3060	NA	NA	NA
Benzene (ppmv)	ND(0.027)	ND(0.06)	ND(0.12)	ND(0.0006)	ND(0.0006)	NA	ND(0.066)	NA	NA	NA
Toluene (ppmv)	ND(0.027)	ND(0.06)	ND(0.12)	ND(0.0006)	ND(0.0006)	NA	ND(0.066)	NA	NA	NA
Ethylbenzene (ppmv)	0.24	0.92	ND(0.12)	ND(0.0006)	ND(0.0006)	NA	0.15	NA	NA	NA
Xylenes (ppmv)	0.34	1.6	ND(0.12)	ND(0.0008)	ND(0.0008)	NA	0.48	NA	NA	NA
Soil Hydrocarbons										
TRPH ^c (mg/kg)	NA	10	43	10	43	NA	3060	NA	NA	NA
Benzene (mg/kg)	NA	ND(0.0006)	ND(0.0006)	ND(0.0006)	ND(0.0006)	NA	ND(0.066)	NA	NA	NA
Toluene (mg/kg)	NA	ND(0.0006)	ND(0.0006)	ND(0.0006)	ND(0.0006)	NA	ND(0.066)	NA	NA	NA
Ethylbenzene (mg/kg)	NA	ND(0.0006)	ND(0.0006)	ND(0.0006)	ND(0.0006)	NA	0.15	NA	NA	NA
Xylenes (mg/kg)	NA	ND(0.0008)	ND(0.0008)	ND(0.0008)	ND(0.0008)	NA	0.48	NA	NA	NA
Soil Inorganics										
Iron (mg/kg)	36,600	NA	NA	NA	NA	NA	NA	38,700	21,400	21,400
Alkalinity (mg/kg as Ca CO ₃ ^d)	ND(41)	NA	NA	NA	NA	NA	NA	ND(41)	ND(41)	ND(41)
pH (Units)	8.2	NA	NA	NA	NA	NA	NA	8.5	7.9	7.9
TKN ^e (mg/kg)	ND(41)	NA	360	NA	360	ND(41)	NA	NA	NA	NA
Phosphates (mg/kg)	190	NA	340	NA	340	310	NA	NA	NA	NA

Table 2.1 (Continued)

Soil and Soil Gas Laboratory Analytical Results
 IRP Site 35c
 March AFB, California

Analyte (Units) ^a	Sample Location - Depth (Feet Below Ground Surface)									
	MA1-VW-4	MA1-VW-9	MA1-MPA-4	MA1-MPA-9	MA1-MPB-6	MA1-MPB-9	MPI-MPC-6			
Moisture (% by wt)	3.6	3.5	3.8	2.6	4.9	2.7	3.4			
Gravel (%)	5.3	NA	5.7	4.4	NA	NA	NA			
Sand (%)	86.1	NA	83	84.2	NA	NA	NA			
Silt (%)	4.8	NA	6.3	9.4	NA	NA	NA			
Clay (%)	3.8	NA	5.0	2.0	NA	NA	NA			

^a ppmv = Parts Per Million, by volume; mg/kg = Milligrams Per Kilogram

^b TVH = Total Volatile Hydrocarbons by EPA TO-3.

^c TRPH = Total Recoverable Petroleum Hydrocarbons by EPA 418.1.

^d Ca CO₃ = Calcium Carbonate

^e TKN = Total Kjeldahl Nitrogen

ND = None Detected. Detection limits are in parentheses.

NA = Not Analyzed

concentrations ranged from 8.5 ppmv in MA1-VW to 290 ppmv at seven feet bgs in MA1-MPB. A TVH concentration of 110 ppmv was detected at four feet bgs in MA1-MPC despite no signs of soil contamination.

2.3 Pilot Test Results

2.3.1 Exceptions to Test Protocol Procedures

Procedures described in the protocol document and the site-specific work plan (Part I) were used to complete the pilot test at this site. An exception to the protocol document included collecting a soil gas sample from MA1-MPB in stead of MA1-MPA. This was due to the higher field TVH reading in MPB. Exceptions to the Part I work plan included extending the total depths of the VW and MPs due to deeper than expected soil contamination. For this same reason, MPs were located further away from the VW than described in the Part I work plan.

2.3.2 Initial Soil Gas Chemistry

Prior to initiating air injection for the respiration test, the VW and all MPs were purged, and initial oxygen, carbon dioxide, and TVH concentrations were measured using portable gas analyzers, as described in the protocol document.

Table 2.2 summarizes the initial soil gas chemistry at the site. The results strongly indicate that biological fuel degradation has depleted the oxygen supply in the vadose zone below a depth of 4 feet. MA1-MPA and MA1-MPB, below 4 feet bgs, contained oxygen levels ranging from 0 to 0.8 percent. Oxygen concentrations at four feet in MA1-MPA and MA1-MPB were 15.5 and 13.0 percent, respectively. Relatively high percentages of oxygen at four feet may be a result of diffusion from the surface, or from lower soil contamination levels at this depth. The VW was also screened through this shallow zone, which is probably why the initial oxygen concentration was measured as 5.0 percent. The seven and ten foot zones of MA1-MPC, installed in apparently uncontaminated soil, had a slightly reduced oxygen concentration of 16.2 and 14.6 percent, respectively. Carbon dioxide was present at an elevated concentration in the VW and all MPs except MA1-MPC-4. Elevated carbon dioxide concentrations ranged from 2.3 to 11.2 percent.

A background MP (MA-BG) was installed in an empty field approximately 0.5 miles northeast of IRP Site 35c. The site was selected as a common background point midway between IRP Sites 35c and 35a (as previously described, Site 35a had insufficient levels of soil contamination to warrant a pilot test). Oxygen concentrations in the background MP ranged from 19 to 19.5 percent. Carbon dioxide concentrations were approximately 0.08 percent. Soil gas concentrations observed in the background MP indicate that almost all of the oxygen reduction observed at IRP Site 35c is due to the aerobic activity associated with site contamination and is not a function of natural soil conditions.

2.3.3 In Situ Respiration Rates

An *in situ* respiration test was conducted at the site according to protocol document procedures. Two 1-cfm pumps were used to inject air into MA1-MPB-7 and MA1-MPB-10 for 20-hours. Due to the high initial oxygen concentration of 13 percent, a respiration test was not conducted at MA1-MPB-4. A dilution chamber was used to inject helium into the MPs. During the 20-hour air injection period, a Mark helium

Table 2.2
Initial Soil Gas Chemistry
IRP Site 35c
March AFB, California

Sample Location	Depth (ft bgs)	O ₂ (percent)	CO ₂ (percent)	TVH-Field (ppmv) ^a	TVH-Lab (ppmv) ^b	Temperature (°F)
MA1-VW	4-11	5.0	11.2	820	85	NA
MA1-MPA-4	4	15.5	3.2	940	NA	NA
MA1-MPA-7	7	0.8	11.2	820	NA	NA
MA1-MPA-10	10	0.5	9.2	540	NA	NA
MA1-MPB-4	4	13.0	4.5	500	NA	61.2
MA1-MPB-7	7	0.0	11.0	1200	290	NA
MA1-MPB-10	10	0.0	11.0	1200	NA	66.2
MA1-MPC-4	4	19.0	0.03	220	110	NA
MA1-MPC-7	7	16.2	2.8	460	NA	NA
MA1-MPC-10	10	14.6	2.3	490	NA	NA

^a Total hydrocarbon analyzer field screening results.

^b Laboratory results referenced to Jet Fuel (Molecular Weight = 156)

NA = Not Analyzed

During the air injection period, oxygen concentrations at each point in MPB were increased to at least 18.5 percent. After air injection ceased, changes in soil gas composition were monitored over time. Oxygen, carbon dioxide, TVH, and helium were measured over a period of approximately 57 hours following the air injection period. The observed rates of oxygen utilization were then used to estimate the aerobic fuel degradation rates at the site using procedures outlined in Section 5.7 of the protocol document. Figures 2.6 and 2.7 present the results of *in situ* respiration testing at the site, and Table 2.3 provides a summary of the observed oxygen utilization rates. The oxygen utilization rates observed in contaminated soils ranged from 0.2495 percent per hour (%/hr) to 0.3215 %/hr, indicating that biological activity is associated with the zone of highest soil contamination. Helium levels remained relatively constant when compared to oxygen utilization, indicating that MP leaks were not contributing to oxygen loss.

An estimated 950 to 980 milligrams (mg) of fuel per kilogram (kg) of soil can be degraded each year. The fuel consumption rates were calculated using the observed oxygen utilization rate in MA1-MPB-7 and MA1-MPB-10 an estimated air-filled porosity of 0.091 liters of air/kg of soil, and a conservative ratio of 3.5 mg of oxygen consumed for every 1 mg of fuel biodegraded.

Respiration Test
 March AFB, California
 MA1-MPB-7

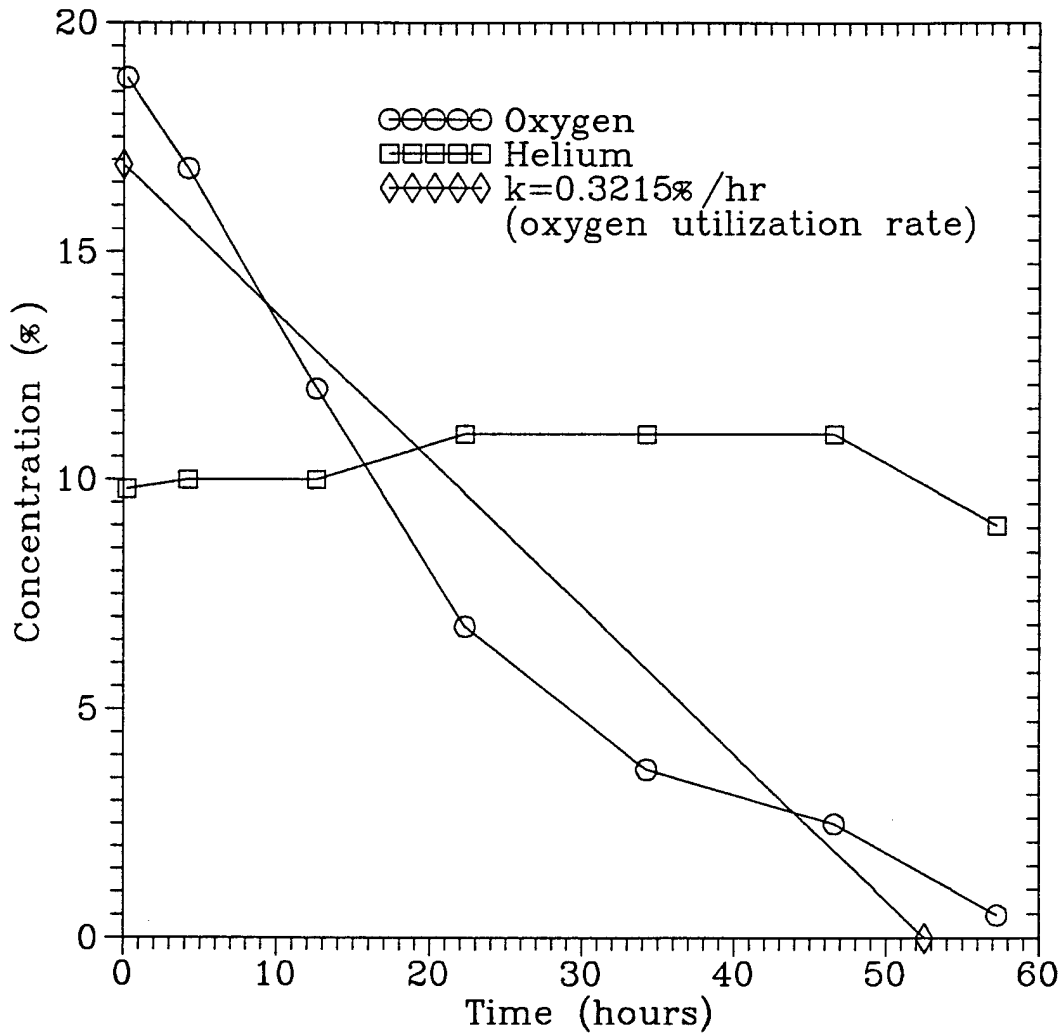

FIGURE 2.6
 RESPIRATION TEST
 MA1-MPB-7
 IRP SITE 35C
 FORMER DIESEL UST AREA
 MARCH AFB, CALIFORNIA

ENGINEERING-SCIENCE, INC.
 La Jolla, California



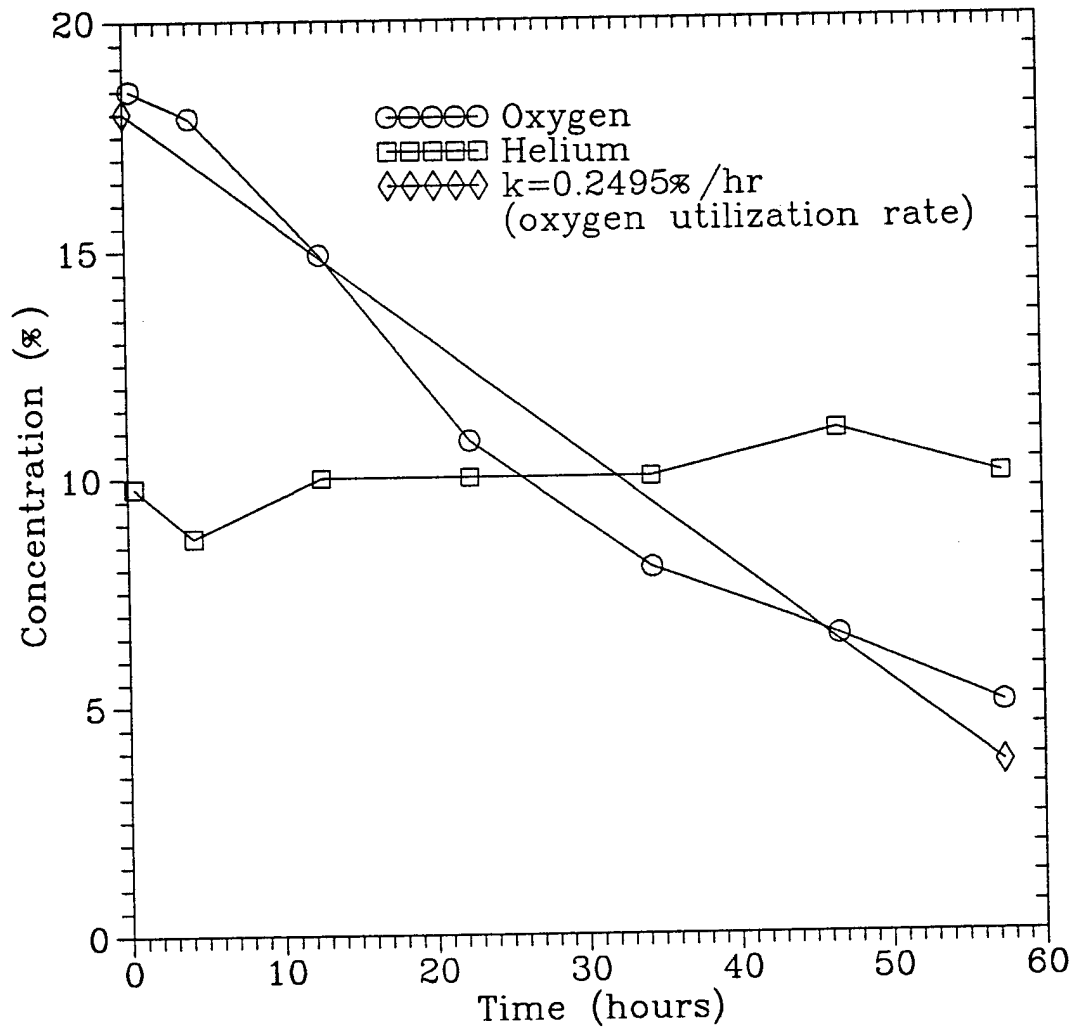

FIGURE 2.7
 RESPIRATION TEST
 MA1-MPB-10
 IRP SITE 35C
 FORMER DIESEL UST AREA

MARCH AFB, CALIFORNIA

ENGINEERING-SCIENCE, INC.
 La Jolla, California



Table 2.3
Oxygen Utilization Rates
IRP Site 35c
March AFB, California

Location	O ₂ Loss ^a (percent)	Test Duration (hr)	O ₂ Utilization ^a Rate (percent/hr)	Hydrocarbon Degradation Rate (mg/kg/yr)
MA1-MPB-7	18.25	57.7	0.3215	980
MA1-MPB-10	14.70	58.0	0.2495	950

^a Value based on linear regression (Figure 2.6 and 2.7).

2.3.4 Air Permeability

An air permeability test was conducted at the site according to protocol document procedures. Air was injected into the VW for approximately 20 hours at a rate of approximately 12.5 cfm and an average pressure of approximately 4.5 psi. The pressure responses at each MP are listed in Table 2.4. The pressure measured at most MPs stabilized within the first 3 or 4 minutes. The steady-state method of determining air permeability as detailed in the protocol document was used to calculate a soil gas permeability value of 1.22 darcys. A minimum radius of pressure influence of 31 feet was observed at 7 and 10 feet bgs.

2.3.5 Oxygen Influence

The depth and radius of oxygen influence in the subsurface resulting from air injection into the central VW during pilot testing is the primary design parameter for full-scale bioventing systems. Optimization of full-scale and multiple VW systems requires pilot testing to determine the volume of soil that can be oxygenated at a given flow rate and VW screen configuration.

Table 2.5 describes the change in soil gas oxygen levels that occurred after 20 hours of air injection during the air permeability test at the site. This air injection period at 12.5 cfm produced changes in soil gas oxygen levels at a distance of at least 31 feet from the central VW at all depths in MA1-MPC.

Assuming the VW is near the center of contamination, the observed radius of influence should be sufficient to treat all diesel tank-related contaminated soil at the site.

2.3.6 Potential Air Emissions

Site contamination consists of diesel fuel, a compound of relatively low volatility. Soil samples had maximum field head space readings of 128 ppm. The maximum TVH concentration determined by laboratory analysis was 290 ppmv. Of the BTEX compounds, only ethyl benzene and total xylenes at maximum concentrations of 0.92ppmv and 1.6 ppmv, respectively, were detected. The long-term potential for air

Table 2.4
Pressure Response (inches of water) During Air Permeability Test
IRP Site 35c
March AFB, California

Elapsed Time (Minutes)	Location Depth (ft. bgs)								
	MPA			MPB			MPC		
	4	7	10	4	7	10	4	7	10
0	0.0	0.0	0.0	0.0	0.0	0.0	0.0	0.0	0.0
1	1.0	18.0	30.0	0.8	2.8	8.0	0.0	0.3	0.3
2	2.20	18.0	32.0	1.4	3.4	9.5	0.0	0.4	0.5
3	2.80	19.0	32.0	1.3	3.6	10.0	0.05	0.45	0.55
4	3.10	19.0	32.0	1.3	3.6	10.3	0.05	0.45	0.55
5	3.20	19.0	32.0	1.3	3.6	10.3	0.05	0.45	0.6
6	3.25	19.0	32.0	1.3	3.6	10.3	0.05	0.5	0.6
7	3.30	19.0	32.0	1.3	3.6	10.3	0.03	0.45	0.6
8	3.30	19.0	32.0	1.3	3.6	10.3	0.03	0.5	0.6
9	3.30	19.0	32.0	1.3	3.6	10.3	0.03	0.5	0.6
10	3.30	19.0	32.0	1.3	3.6	10.3	0.03	0.5	0.6
11	3.30	19.0	32.0	1.3	3.6	10.3	0.03	0.5	0.6
12	3.30	19.0	32.0	1.3	3.6	10.3	0.03	0.5	0.6
13	3.30	19.0	32.0	1.3	3.6	10.3	0.03	0.5	0.6
14	3.30	19.0	32.0	1.3	3.6	10.3	0.01	0.5	0.6
15	3.30	19.0	31.5	1.3	3.6	10.3	0.01	0.5	0.6
16	3.30	19.0	31.0	1.3	3.6	10.3	0.01	0.5	0.6
17	3.30	19.0	31.0	1.3	3.6	10.3	0.01	0.5	0.6
18	3.30	18.5	31.0	1.35	3.6	10.3	0.01	0.5	0.6
19	3.30	18.5	31.0	1.35	3.6	10.3	0.01	0.5	0.6
20	3.30	18.5	31.0	1.35	3.6	10.3	0.01	0.5	0.6
22	3.30	18.5	31.0	1.35	3.6	10.3	0.01	0.5	0.6
24	3.30	18.5	31.0	1.35	3.6	10.3	0.01	0.5	0.6
26	3.30	18.5	31.0	1.25	3.6	10.3	0.01	0.5	0.6
28	3.30	18.0	31.0	1.35	3.6	10.3	0.01	0.5	0.6
30	3.30	18.5	31.0	1.35	3.6	10.3	0.01	0.45	0.55
40	3.30	18.0	30.0	1.35	3.6	10.3	0.0	0.45	0.55
50	3.30	18.0	30.0	1.35	3.6	10.3	0.0	0.45	0.55
60	3.25	17.7	30.0	1.3	3.6	10.3	0.0	0.45	0.55
70	3.25	17.5	30.0	1.3	3.6	10.3	0.0	0.45	0.55
80	3.25	17.5	30.0	1.3	3.6	10.3	0.0	0.45	0.55
100	3.25	17.5	29.5	1.3	3.6	10.3	0.0	0.45	0.55
110	3.20	17.5	29.0	1.3	3.6	10.3	0.0	0.45	0.55
120	3.20	17.25	29.0	1.3	3.6	10.3	0.0	0.45	0.55

Table 2.5
Influence of Air Injection Vent Well on Monitoring Point Oxygen Levels
IRP Site 35c
March AFB, California

Sample Location	Distance from VW (ft)	Depth (ft. bgs)	Initial O ₂ ^a (percent)	Final O ₂ ^b (percent)
MA1-MPA-4	6	4	3.8	19.5
MA1-MPA-7	6	7	2.0	20.5
MA1-MPA-10	6	10	0.5	20.0
MA1-MPB-4	11	4	10.0	18.5
MA1-MPB-7	11	7	1.0	19.3
MA1-MPB-10	11	10	1.0	20.3
MA1-MPC-4	31	4	6.0	10.7
MA1-MPC-7	31	7	17.0	19.8
MA1-MPC-10	31	10	15.5	18.5

^a Readings taken before air permeability test.

^b Readings taken after 20 hours of air injection during air permeability test.

emissions from full scale bioventing operations at this site is low. Initial emissions should be minimal because accumulated vapors will move slowly outward from the air injection point and will be biodegraded as they move horizontally through the soil. During the air permeability test, air was injected at 12.5 cfm. Health and safety hydrocarbon-analyzer air monitoring of the breathing zone at the site indicated that total hydrocarbon concentrations did not increase above 1 ppmv during the initial days of the test. The initial day of bioventing generally produces the highest potential for emissions as the first pore volume of soil gas is replaced.

2.4 Recommendations

Initial bioventing tests at this site indicate that oxygen had been depleted in the contaminated soils, and that air injection is an effective method of stimulating aerobic fuel biodegradation. AFCEE has recommended that air injection continue at this site to determine the long-term radius of oxygen influence and the effects of time, available nutrients, and changing temperatures on fuel biodegradation rates.

A 1-horsepower rotary vane blower has been installed at the site for continuous air injection. In September 1994, ES will return to the site to sample and analyze the soil gas and conduct a repeat respiration test. In April 1995, a final respiration test will be conducted, and soil and soil gas samples will be collected from the site to determine the degree of remediation achieved during the first year of *in situ* treatment.

3.0 REFERENCES

Engineering-Science, Inc. 1992. *Field Sampling Plan for AFCEE Bioventing*. Denver, Colorado.

Hinchee, R.E., Ong, S.K., Miller, R.N., Downey, D.C., Frandt, R., 1992. *Test Plan and Technical Protocol for a Field Treatability Test for Bioventing*, January.

TetraTech, Inc. 1993. Preliminary Analytical Results and Draft Boring Logs, Site 35a and Site 35c. (Information not completely quality checked or validated.)

APPENDIX A
O&M INSTRUCTIONS

**ROTARY VANE BLOWER
OPERATION AND MAINTENANCE MANUAL
FOR EXTENDED TESTING SYSTEM AT
MARCH AIR FORCE BASE,
IRP SITE 35C**

Prepared for:

**AIR FORCE CENTER FOR ENVIRONMENTAL EXCELLENCE
BROOKS AFB, TEXAS**

USAF CONTRACT F33615-90-D-4014, DELIVERY ORDER 14

APRIL 1994

Prepared by:

**Engineering-Science, Inc.
199 South Los Robles Avenue
Pasadena, California**

SECTION 1

INTRODUCTION

This document has been prepared by Engineering-Science, Inc. (ES), to support the bioventing initiative contract awarded by the Air Force Center for Environmental Excellence. This contract involves conducting bioventing pilot tests at 110 sites on 38 Air Force bases across the United States.

At most sites, bioventing systems will be installed upon completion of the bioventing pilot tests for the purpose of extended pilot testing. These systems will operate for a one-year period to provide further information as to the feasibility of this technology at each site, and to provide interim remedial action.

The Operation and Maintenance Manual has been created for sites at which blowers have been installed for extended pilot testing. Basic maintenance of these systems is the responsibility of the base. This manual is to be used by base personnel to guide and assist them in operating and maintaining the blower system. Section 2 provides a synopsis of the blower system configuration. Section 3 describes the blower. Section 4 details the maintenance requirements and provides maintenance schedules. Section 5 describes the system monitoring that is required to forecast system maintenance needs and provide data for the extended pilot test.

SECTION 2

BLOWER SYSTEM CONFIGURATION SUMMARY

System Type injection

Blower rotary vane

Blower Model 1070-P121-G624X

Motor (Horsepower) 1

Knock-Out Chamber none

Sampling Port none

Inlet Temperature Gauge (range) none

Inlet Vacuum Gauge (range) none

Inlet Filter (part no.) K563

Outlet Temperature Gauge 0°-250° F, Ashcroft part# 30EI 60R 025



Outlet Pressure Gauge (range) 0 - 30 PSI (part #AA644B)

Outlet Filter (part no.) K563

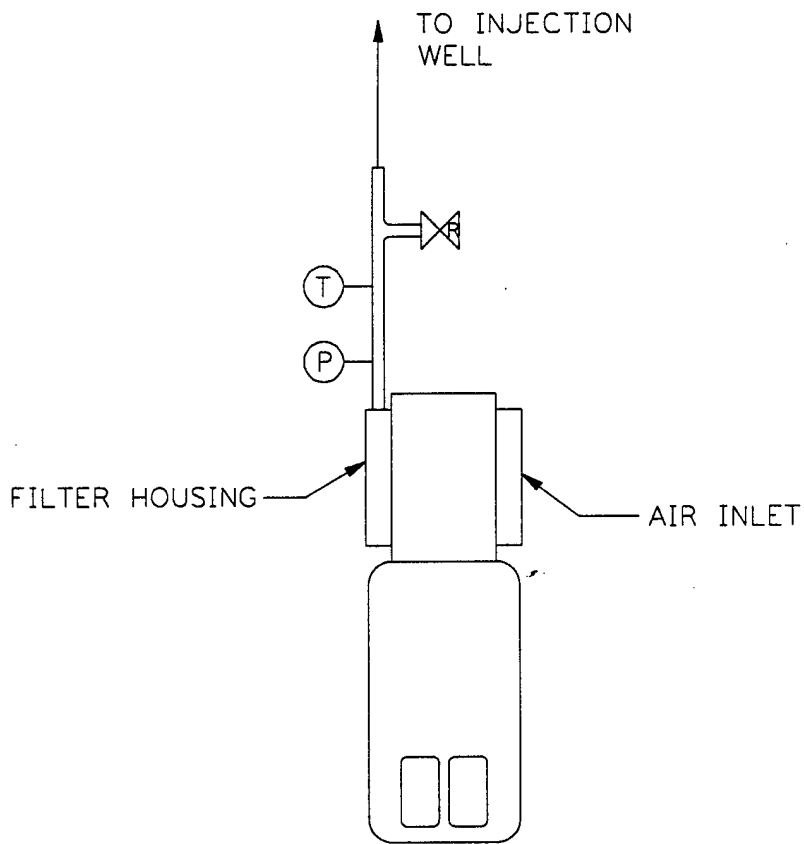
Pressure Relief Valve Set at 10 PSI (part #AA307)



LEGEND

- 
 TEMPERATURE GAUGE (1/4" NPT)
- 
 PRESSURE GAUGE (1/4" NPT)
- 
 PRESSURE BLEED VALVE

ROTARY VANE BLOWER
SYSTEM FOR AIR
INJECTION

NOT TO SCALE

ENGINEERING-SCIENCE, INC.
Pasadena, California

ES

SECTION 3

BIOVENTING SYSTEM OPERATION

3.1 PRINCIPLE OF OPERATION

Bioventing is the forced injection of fresh air, or withdrawal of soil gas, to enhance the supply of oxygen for *in situ* bioremediation. Either a pressure (air injection) or vacuum (vapor extraction) blower unit is used to inject or withdraw air into or from the soil, thereby supplying fresh air with 20.8 percent oxygen to the contaminated soils. Once oxygen is provided to the subsurface, existing bacteria will proceed to break down the fuel residuals.

An injection blower system of the type described below has been installed at the March Air Force Base, IRP Site 35c.

3.2 SYSTEM DESCRIPTION

3.2.1 Blower System

A low flow, oilless, motor mounted Gast Series 1070, , rotary vane blower powered by a 1 horsepower direct-drive motor was installed at Site 35c. This blower is rated at a flow rate of 14 standard cubic feet per minute (scfm) at open flow; however, the actual performance of the blower will vary with changing site conditions. As installed at Site 35c, the blower was producing an estimated flow rate of 12.5 scfm at a pressure of 4.5 psi. The system includes air filters to remove any particulates which are entrained in the air stream, and several valves and monitoring gauges which are described in the next section. A schematic of the blower system installed at Site 35c is shown on the figure in Attachment A. Corresponding blower performance curves and relevant service information are also provided in Attachment A.

3.2.2 Monitoring Gauges

The bioventing system is equipped with a pressure gauge which was installed on the blower outlet piping. See the figure in the attachment for the location of the gauge installed on the blower system.

SECTION 4

SYSTEM MAINTENANCE

Although the motor and blower are relatively maintenance free, periodic system maintenance is required for proper operation and long life. Recommended maintenance procedures and schedules are described in detail in the instruction manuals included in Appendices A and B, and are briefly summarized in this section.

4.1 BLOWER AND MOTOR

The blower and motor are relatively maintenance free and should not require any periodic maintenance during the one-year extended testing period. Both blower and motor have sealed bearings and do not require lubrication.

4.2 AIR FILTER

To avoid damage caused by passing solids through the blower, air filters have been installed in-line on the blower inlet and outlet. This filter element is composed of paper. The filter should be checked weekly for the first two months of operation. A facility employee should determine the best schedule for filter replacement. If replacement filters are not immediately available, one may remove some of the solids accumulated on the filter element by using pressurized air or mechanical agitation. Filter elements may also be cleaned using a solvent (manufacturer recommends part number AH255).

Filter inspection must be performed with the system turned off. To remove the filters, unscrew the five screws on the square housing into which the air injection piping runs. Two filters are located inside. The lower one is the inlet filter.

The filter elements are manufactured by Gast Manufacturing Corp. in Benton Harbor, Michigan. Their telephone number is (616) 926-6171. Additional filters can also be obtained through Engineering-Science, Inc., in La Jolla, California. The ES contact is Mr. Larry Dudus. He can be reached at (619)453-9650. The filter model number is K563. It is recommended that at least one spare air filter be kept at the site; five replacement filters were supplied with the blower system.

4.3 MAINTENANCE SCHEDULE

The following maintenance schedule is recommended for this system. The filter should be checked once per month and cleaned or replaced as necessary (see Section 5.2). During the initial months of operation, more frequent monitoring is

recommended to ensure that any startup problems are quickly corrected. A daily drive-by inspection is recommended during the initial two weeks of operation to ensure that the blower system is still operating with no unusual sounds. Data collection sheets that can be used to record maintenance activities are included in Attachment B.

4.4 TROUBLESHOOTING

<u>Symptoms</u>	<u>Possible Diagnosis</u>	<u>Possible Remedy</u>
Excess Vibration	Vane damaged by foreign material. Vane contaminated by foreign material.	Replace vanes Clean vanes Flush blower Replace filters
Abnormal Sound	Motor bearing failed. Vane rubbing against cover or housing.	Replace bearings Repair blower Check clearances
Blown Fuse	Electrical wiring problem.	Have qualified person check fuse capacity and wiring.
Unit Very Hot	Running at too high a pressure/vacuum.	Install or adjust relief valves.

4.5 MAJOR REPAIRS

Blowers systems are very reliable when properly maintained. Occasionally, a motor or blower will develop a serious problem. If a blower system fails to start, and a qualified electrician verifies that power is available at the blower or starter, the ES Site Manager, Mr. Larry Dudus, should be called at (619) 453-9650. ES is responsible for major repairs during the first year of operation.

SECTION 5

SYSTEM MONITORING

5.1 BLOWER PERFORMANCE MONITORING

To monitor the blower performance, vacuum and pressure will be measured. These data should be recorded weekly on a data collection sheet (provided in Attachment B). All measurements should be taken at the same time while the system is running. Because the system is loud, hearing protection should be worn at all times.

5.1.1 Pressure

With hearing protection in place, open the blower enclosure and record the pressure reading directly from the gauge (in psi). Record the measurements on a data collection sheet (Attachment B).

5.1.2 Flow Rate

The flow rate through the vent well and soils can be calculated when the inlet vacuum (assumed zero in this case) and outlet pressure of the blower are known. This pressure change across the blower (vacuum + pressure) can be compared to the performance curves for the blower in Attachment A to determine the approximate flow rate. Inlet vacuum can be assumed to be approximately zero.

5.3 MONITORING SCHEDULE

The following monitoring schedule is recommended for this system. During the initial months of operation, more frequent monitoring is recommended to ensure that any start up problems are quickly corrected. Data collection sheets have been provided to assist in data collection, and are included in Attachment B.

<u>Monitoring Item</u>	<u>Monitoring Frequency</u>
Pressure	Once per week.
Temperature	Once per week.

ATTACHMENT A

Oilless 70 Series

PRESSURE

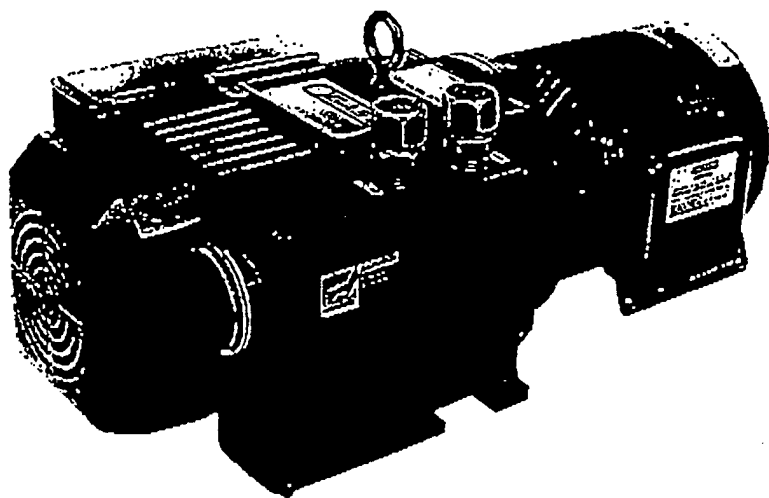

Unit pictured with optional plumbing and pressure regulator.

MODEL 1070 SERIES
15 PSI MAX. PRESSURE, 14 CFM OPEN FLOW

MODEL 2070 SERIES
15 PSI MAX. PRESSURE, 20 CFM OPEN FLOW

PRODUCT FEATURES

- Oilless operation
- Rugged construction/Low maintenance
- Low noise

INCLUDES

- Internal sound suppression
- Heavy duty internal filtration

RECOMMENDED ACCESSORIES

- Pressure regulator (AN225), metric version (AN225A)
- Pressure gauge (AA644B)
- Pressure relief valve (AA307)
- Complete repair kit K562
- Filter/Muffler kit K563

COMMON MOTOR OPTIONS AVAILABLE

- 100-110/200-240; 100-115/200-230; 50/60 Hz, single phase
- 110/220-240; 115/208-230; 50/60 Hz, single phase
- 200-240/200-230; 50/60 Hz, single phase
- 230/460; 60 Hz, three phase

Various brand name motors are used on any model at the discretion of Gast Manufacturing Corp.

Important Notice:

Pictorial and dimensional data is subject to change without notice.

Product Dimensions Metric (mm) U.S. Imperial (inches)

Top View

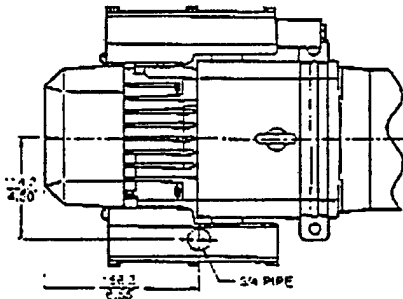

Side View

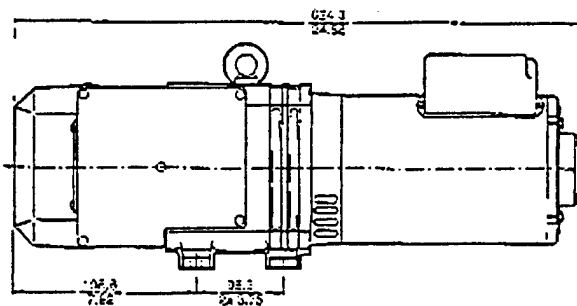

End View

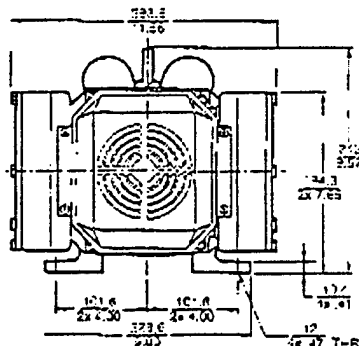

NOTE: Standard units are not drilled/tapped to include regulators/gauges. Consult factory for specific models.

Product Specifications

Model Number	Motor	RPM		HP	KW	Net Wt.	
		60 Cycle	50 Cycle			Lbs.	kg
*1070-P121-G624X	100-110/200-240; 100-115/200-230; 50/60-1	1725	1425	1	0.75	100	45.4
*1070-P135-G561X	110/220-240; 115/208-230; 50/60-1	1725	1425	1	0.75	100	45.4
*2070-P121-T900X	200-240/200-230; 50/60-1	1725	1425	1 1/2	1.12	100	45.4
*2070-P135-G475	230/460-60-3	1725	—	2	1.5	100	45.4

- * 10 psi maximum performance
- * High pressure models (15 psi)

*Product Performance (Metric, U.S. Imperial) Black line on curve is for 60 cycle performance. Colored line on curve is for 50 cycle performance.

1070

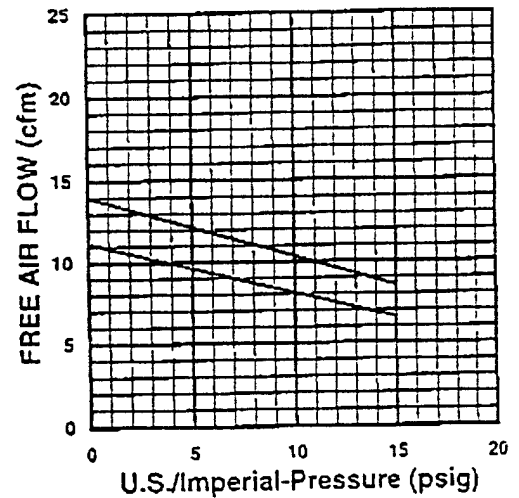
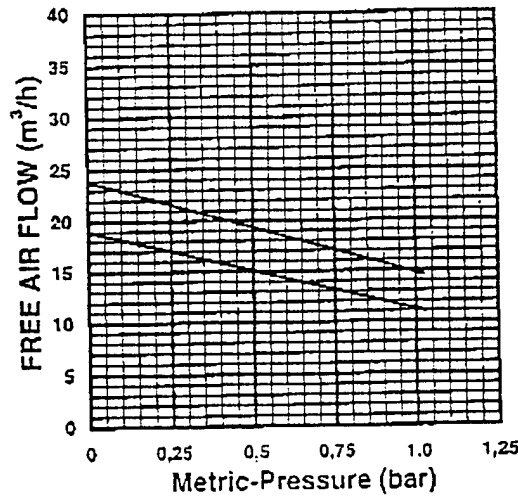

2070

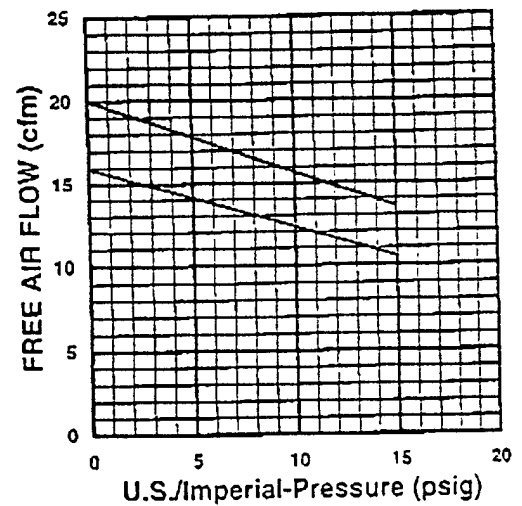
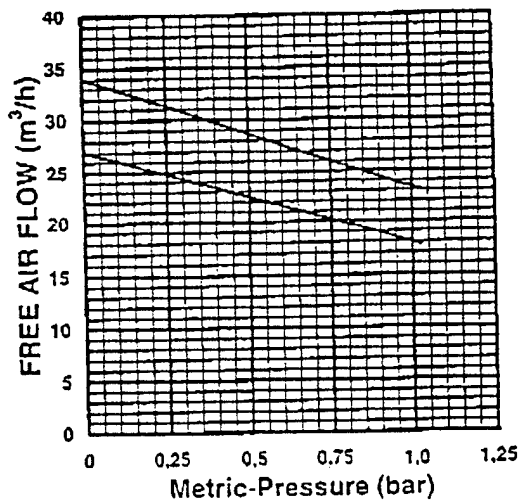

*Performance curves shown are without accessories. The addition of a regulator will decrease the maximum duty and flow. The amount of reduction will vary depending on the application and duty selected.



70 and 80 Series Vacuum Pumps, Compressors and Dual-Function Pumps

FEATURES

SIMPLE TO USE—Hassle-free units run without oil; therefore, you'll never burn up a pump that needed oil replacement. Also, you'll never blow oil on your finished product, process, or employees. The large, easy-to-service internal filters will perform for thousands of hours (depending on application) without maintenance.

QUIET—Low noise levels allow these units to operate without sophisticated, additional muffling—even in the office environment of small businesses. Sound levels vary between 62 and 75 db(A), depending on model selected and application.

RUGGED—Units withstand pressures and vacuums unachievable by competitive pumps on a continuous basis. As compressors, the "80" series operate up to 15 psig (1.03 bar) and as vacuum pumps to 26" Hg (133 mbar). The "70" series operate to 15 psig (1.03 bar) and 25" Hg (167 mbar).

ECONOMICAL—These units are not only competitively priced, they operate as both compressors and vacuum pumps simultaneously (when specified). Life of the pumps as double-function units meets or exceeds over our own single-function units, and variations in duty on either port have negligible effect on the flow and duty of the other.

Accessories/Kits



Gauges

- Vacuum Gauge AA640 (1/2" NPT, Bottom Mount)
- Vacuum Gauge AE136 (1/4" NPT, Back Mount)
- Pressure Gauge AA644B (1/2" NPT, Bottom Mount)
- Pressure Gauge AN190 (1/2" NPT, Back Mount)



Regulators

- Vacuum Regulator AN226 (1/2" NPT, 15-55 cfm)
- Vacuum Regulator AN226A (1/2" BSP, 25-93 m³/h)
- Pressure Regulator AN225 (1/2" NPT, 15-45 cfm)
- Pressure Regulator AN225A (1/2" BSP, 25-76 m³/h)
- Pressure Regulator AN225B (1/2" NPT, 45-75 cfm)
- Pressure Regulator AN225C (1/2" BSP, 76-127 m³/h)

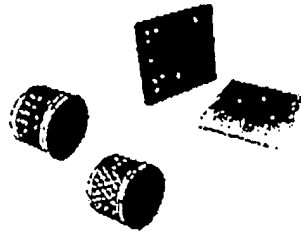

Filter/Muffler Kits

- 70 Series Vacuum Pumps K561
- 70 Series Compressors K563
- 70 Series Dual-Function Pumps K565
- 80 Series Vacuum Pumps K552
- 80 Series Compressors K547
- 80 Series Dual-Function Pumps K547

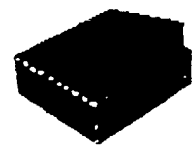

Complete Rebuild Kit

- 70 Series Vacuum Pumps K560
- 70 Series Compressors K562
- 70 Series Dual-Function Pumps K558
- 80 Series Vacuum Pumps K546
- 80 Series Compressors K551
- 80 Series Dual-Function Pumps K551

If your need for our 70 or 80 Series pump is in the graphic arts equipment area, particularly in replacing either a European model or another kind, please refer to the following chart. Gast offers a rugged, competitively priced alternative to a variety of models.

GAST	BECKER	RIETSCHLE	BUSCH	ORION
1C70-V122-G624X	VT3.18	VFT25	SV1016	—
2C70-V122-T900X	VT3.25	TL25V	SV1025	KRS5-SS
3C60-V122-T937	—	VFT40/TR40V	—	KRS6-SS
3C60-V122-T937	VT3.40	VFT60/TR60V	SV1040	—
4C80-V122-T339	KVT2.60	VFT80/TR80V	—	KRS8-SS
1070-P121-G624X	DT3.16	TL250/TR250	SD1016	—
2C70-P121-T900X	DT3.25	—	SD1025	KRS5-SS
2C60-P121-T937	—	TR41J	SD1040	KRS6-SS
3C80-P121-T336	DT3.40	TR51D/CLT61D	—	—
4C90-P121-T339	KOT2.60	TR81D/CLFT81C	—	KRS9-SS
1C70-D123-G624X	T3.16DSK	—	—	—
2C70-D123-T900X	T3.25DSK	CLFT260V/TR260V	DC0025	—
2C60-D123-T937	—	CLFT410V/TR410V	—	—
3C80-D123-T336	T3.40DSK	CLFT610V/TR610V	DC0040	—
4C90-D123-T339	DT2.60	CLFT810V/TR810V	DC0063	—

* 70 and 80 series units can also be used to replace ORION combination (2) pumps

APPLICATIONS

- Small printing presses
- Paper folders
- Carton formers
- Material handling equipment
- Collators
- Food processing equipment

Warranty

REGARDLESS OF CAUSE, if a product you buy from this brochure does not work right, Gast will repair or replace it once, at no charge, for up to one year from the date of shipment from the factory. In the course of repair or replacement, Gast may send you written recommendations on how to prevent a problem from happening again. Gast reserves the right to withdraw this warranty if you do not follow these recommendations. Customer is responsible for freight charges both to and from Gast in all cases.

This warranty does not apply to electric motors, electrical controls, and gasoline engines, which Gast obtains from other manufacturers. A motor power group carries only the warranty of the company that makes it. THIS WARRANTY IS EXCLUSIVE AND IS IN LIEU OF ALL OTHER WARRANTIES, WHETHER WRITTEN, ORAL OR IMPLIED, INCLUDING THE WARRANTY OF MERCHANTABILITY AND OF FITNESS FOR ANY PARTICULAR PURPOSE. GAST'S LIABILITY IS IN ALL CASES LIMITED TO THE REPLACEMENT PRICE OF ITS PRODUCT. GAST SHALL NOT BE LIABLE FOR ANY OTHER DAMAGES, WHETHER CONSEQUENTIAL, INDIRECT, OR INCIDENTAL, ARISING FROM THE SALE OR USE OF ITS PRODUCTS. Gast's sales personnel may modify this warranty, but only by signing a specific written description of any modifications.





INSTALLATION INSTRUCTIONS

Rotary Vane Pump Service Kit

70 Series

This is the hazard alert symbol:  When you see this symbol, be aware that personal injury or property damage is possible. The hazard is explained in the text following the symbol. Read the information carefully before proceeding.

The following is an explanation of the three different types of hazards:

-  **DANGER** Severe personal injury or death will occur if hazard is ignored.
-  **WARNING** Severe personal injury or death can occur if hazard is ignored.
-  **CAUTION** Minor injury or property damage can occur if hazard is ignored.

You can return the pump to a Gast authorized service facility, or perform the rebuild procedures described below.

NOTE: Gast will not guarantee the performance of a field-rebuilt pump.

SERVICE KIT INSTALLATION

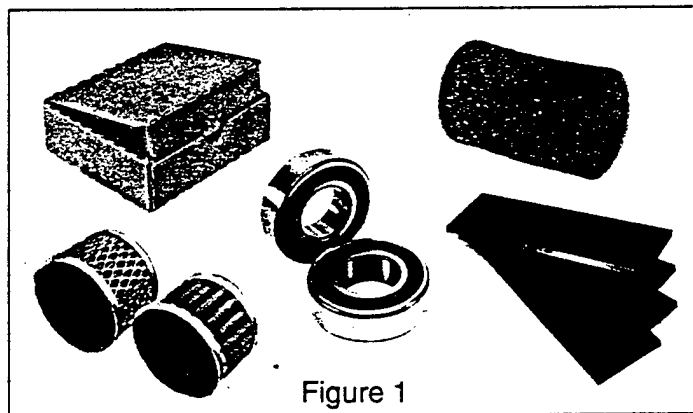



Figure 1

Each service kit contains most or all of the following: bearings, vanes, gaskets (not pictured) and filter elements.

Follow these general steps to install the kit:

Pump Disassembly:

1. Disconnect the pump from electrical power.

 **WARNING** You must disconnect the pump from electrical power before servicing it. Failure to do so can result in severe personal injury or death.

2. Vent all air lines to the pump to remove pressure.

 **WARNING** You must vent all air lines to the pump to remove pressure before servicing it. Failure to do so can result in severe personal injury.

3. Remove the shroud and fan (see Figure 2).
4. Use a wheel puller to remove the dead-end plate and bearing from the pump body. Do not damage the dowel pins between the end plate and the body. Save the shoulder ring on the dead-end of the shaft for reassembly. Remove the snap ring from the end plate. Save the snap ring, belleville springs, and washer for reassembly.
5. Remove the bearing from the dead-end plate.
6. Check the exposed surfaces of the rotor, body, and end plate for scoring. If you find no scoring, you can perform a Minor Rebuild to replace only the vanes and the dead-end bearing. If you find severe damage, perform the Major Rebuild.

Minor Rebuild:

7. Install the new vanes supplied with the kit. Be careful to face the vane bevels in the proper direction.
8. Place the shoulder ring on the dead-end of the shaft. Place the new bearing in its bore in the dead-end plate. Assemble the end plate and pump body with the dowel pins as you press the bearing onto the shaft. Be careful to press only on the inner bearing race.
9. Install the belleville springs with the washer between them, and the snap ring. Install and tighten the pump body bolts.

Major Rebuild:

7. Remove the spanner ring. Use a wheel puller to remove the drive-end plate and bearing from the pump body. Do not remove or damage the dowel pins in the body. Save the shoulder ring and body spacer for reassembly.
8. Assemble the drive-end plate, body spacer, and pump body, but do not tighten the bolts. Place one of the new bearings in its seat in the drive-end plate, then place one of the shoulder rings on the drive-end of the shaft. Using an arbor press, press the bearing onto the shaft. Be careful to press only on the inner bearing race. Tighten the pump body bolts.
9. Install the new vanes supplied with the kit. Be careful to face the vane bevels in the proper direction.
10. Place the remaining shoulder ring on the dead-end of the shaft. Place the remaining new bearing in its bore in the dead-end plate. Assemble the end plate and pump body with the dowel pins as you press the bearing onto the shaft. Be careful to press only on the inner bearing race.

11. Install the belleville springs with the washer between them, and the snap ring. Install and tighten the pump body bolts.
12. Apply a thread-lock adhesive and start the spanner ring into its thread in the drive end cap, but do not tighten it.

13. Place a dial indicator against the dead-end of the shaft to measure axial movement. Tighten the spanner ring until the indicator shows .002" to .0025" of shaft movement against the belleville springs.
14. Replace the filter elements.

Shroud and Fan must be removed to access dead-end plate for servicing of vanes.

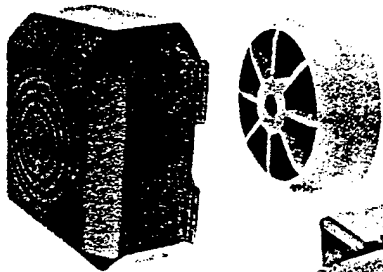

Sound Attenuator with replaceable/washable foam covering. Used on dual function units only. NOTE: Muffler box also only contains foam on dual function units.

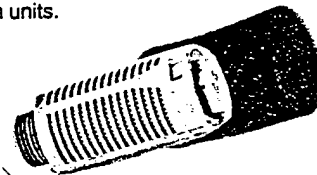

Intake and Discharge Filtration. NOTE: Filter on discharge side is smaller, so as to avoid incorrect replacement by switching the two elements.

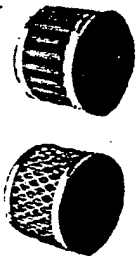

Remove bolts on Muffler Box Plate and remove Gasket to access intake and discharge filtration.

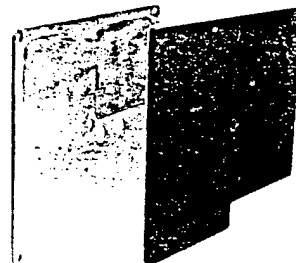

Remove Cover Plate to access 3-piece Coupling (shipped unattached on 3-phase units). Replacement Rubber Section, Part No. AE546.

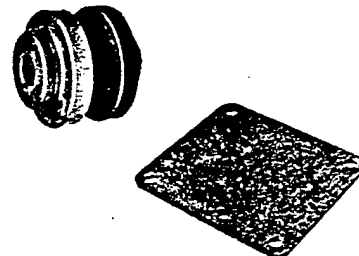

Figure 2

AUTHORIZED SERVICE FACILITIES

Gast Manufacturing Corp.
2300 Hwy. M-139
Benton Harbor, MI 49022
TEL: 616-926-6171
FAX: 616-925-8288

Gast Manufacturing Corp.
505 Washington Avenue
Carlstadt, NJ 07072
TEL: 201-933-8484
FAX: 201-933-5545

Brenner Fiedler & Assoc.
13824 Bentley Place
Cerritos, CA 90701
TEL: 800-843-5558
TEL: 310-404-2721
FAX: 310-404-7975

Gast Manufacturing Co., Ltd.
Beech House, Knaves Beech
High Wycombe, Loudwater
High Wycombe, Bucks HP10 9SD
England
TEL: 44 628 532600
FAX: 44 628 532470

Wainbee Limited
215 Brunswick Blvd.
Pointe Claire, Quebec
Canada H9R 4R7
TEL: 514-697-8810
FAX: 514-697-3070

Wainbee Limited
5789 Coopers Avenue
Mississauga, Ontario
Canada L4Z 3S6
TEL: 416-213-7202
FAX: 416-213-7207

Japan Machinery Co., Ltd.
Central PO Box 1451
Tokyo, 100-91 Japan
TEL: 81-3-3573-5421
FAX: 81-3-3571-7865
or 81-3-3571-7896

NOTE: General correspondence should be sent to—
Gast Manufacturing Corporation
PO Box 97
Benton Harbor, MI 49023-0097

ATTACHMENT B

APPENDIX B

GEOLOGIC LOGS AND CHAIN OF CUSTODY FORMS

Blows/6"	PID (ppm)	ID#/Recov %	DEPTH (ft)	SAMPLES	SYMBOLS	MATERIALS DESCRIPTION
3/3/4	0	100%	5			SAND: dark brown, medium to fine; and SILT: micaceous, no odor, very slightly damp (tank bed fill).
3/3/2	0	66%				SAND: as above, top 6".
						SAND and Decomposed Granite: no odor (tank bed fill).
3/2/2	30	66%	10			Decomposed granite: brown, black, and white; biotite, feldspar; no odor (tank bed fill).
3/2/1	0	80%				Decomposed granite: brown, black, and white; biotite, feldspar; no odor (tank bed fill).
36/36-1"	0	30%	15			Decomposed granite: brown, black, and white; feldspar, biotite; friable, no odor. <i>Total Depth = 14.0' bgs.</i>
			20			
			25			

PROJECT	March Air Force Base	DRILLING COMPANY	Tonto Environmental Drilling
LOCATION	IRP Site 35A, Bldg. 3409	DATE DRILLED	03/16/94
JOB NUMBER	722406.49040	SURFACE ELEVATION	
GEOLOGIST	Larry Dudas	TOTAL DEPTH OF HOLE	14.0 Feet
DRILL RIG	Hollow Stem Auger w/Split Spoon Sampler	WATER LEVEL	

Blows/6"	PID (ppm)	ID#/Recov %	DEPTH (ft)	SAMPLES	SYMBOLS	MATERIALS DESCRIPTION
						SAND: very coarse.
3/6/4	0	66%	5			Decomposed granite and Wood: (fill). Cuttings are lumber fragments.
13/32/50-1	12	66%	10			Decomposed granite: black, white, brown; feldspar and biotite; friable; <u>very slight petroleum odor</u> .
120-6"	50	0%	15			Decomposed granite: black, white, brown; feldspar and biotite; friable; <u>very slight petroleum odor</u> . Poor sample: piece of wood from up-hole plugs sampler.
120-6"	190					Decomposed granite: black, white, brown; feldspar and biotite; friable; <u>very slight petroleum odor</u> .
						Total Depth = 16.0' bgs.
			20			
			25			

PROJECT	March Air Force Base	DRILLING COMPANY	Tonto Environmental Drilling
LOCATION	IRP Site 35A, Bldg. 3409	DATE DRILLED	03/16/94
JOB NUMBER	722406.49040	SURFACE ELEVATION	
GEOLOGIST	Larry Dudus	TOTAL DEPTH OF HOLE	16.0 Feet
DRILL RIG	Hollow Stem Auger w/Split Spoon Sampler	WATER LEVEL	

Blows/6"	PID (ppm)	ID#/Recov %	DEPTH (ft)	SAMPLES	SYMBOLS	MATERIALS DESCRIPTION
2/1/2	0	66%	5			SAND: dark brown, very coarse to fine; some silt, very micaceous; moist, no odor (fill).
3/3/14	0	66%	10			Decomposed granite: black and white; feldspar and biotite; friable, no odor. <u>Note: slight odor in cuttings. 34 ppm.</u>
100/4.5"	0	20%	15			Decomposed granite: black and white; feldspar and biotite; friable, no odor. <u>Note: moderate odor on auger at approximately 14.0' bgs.</u> <i>Total Depth = 15.0' bgs.</i>
			20			
			25			

PROJECT	March Air Force Base	DRILLING COMPANY	Tonto Environmental Drilling
LOCATION	IRP Site 35A, Bldg. 3409	DATE DRILLED	03/16/94
JOB NUMBER	722406.49040	SURFACE ELEVATION	
GEOLOGIST	Larry Dudas	TOTAL DEPTH OF HOLE	15.0 Feet
DRILL RIG	Hollow Stem Auger w/Split Spoon Sampler	WATER LEVEL	

Blows/6"	PTD (ppm)	ID#/Recov %	DEPTH (ft)	SAMPLES	SYMBOLS	MATERIALS DESCRIPTION
						SAND: very coarse.
21/22/33	1300	100%	5			Decomposed granite: brown, black, and white; feldspar, biotite; friable, no odor. <i>Low battery in TIP, field reading suspect.</i>
25/21-3"	600	40%	10			Decomposed granite: brown, black, and white; feldspar, biotite; friable, no odor. <i>New battery in TIP.</i>
23-6"	0	33%				Decomposed granite: brown, black, and white; feldspar, biotite; friable, no odor.
43/50-3"	0	33%	15			Decomposed granite: brown, black, and white; feldspar, biotite; friable, no odor.
120-6"	12	33%	20			Decomposed granite: brown, black, and white; feldspar, biotite; friable, no odor. saturated. <i>Total Depth = 19.0' bgs.</i>
			25			

PROJECT	March Air Force Base	DRILLING COMPANY	Tonto Environmental Drilling
LOCATION	IRP Site 35A, Bldg. 3409	DATE DRILLED	03/17/94
JOB NUMBER	722406.49040	SURFACE ELEVATION	
GEOLOGIST	Larry Dudus	TOTAL DEPTH OF HOLE	19.0 Feet
DRILL RIG	Hollow Stem Auger w/Split Spoon Sampler	WATER LEVEL	18.0 Feet

Blows/6"	PID (ppm)	ID#/Recov %	DEPTH (ft)	SAMPLES	SYMBOLS	MATERIALS DESCRIPTION
						SAND: very coarse.
19/27	0	66%	5			Decomposed granite: black, brown, and white; biotite, feldspar; friable, no odor.
51-6"	0	33%	10			Decomposed granite: black, brown, and white; biotite, feldspar; friable, no odor.
54-6"	0	33%				Decomposed granite: black, brown, and white; biotite, feldspar; friable, no odor.
78-6"	0	33%	15			Decomposed granite: black, brown, and white; biotite, feldspar; friable, no odor.
120-6"	0					Decomposed granite: black, brown, and white; biotite, feldspar; friable, no odor; saturated. <i>Total Depth = 18.0' bgs.</i>

PROJECT	March Air Force Base	DRILLING COMPANY	Tonto Environmental Drilling
LOCATION	IRP Site 35C, Bldg. 3406	DATE DRILLED	03/17/94
JOB NUMBER	722406.49040	SURFACE ELEVATION	
GEOLOGIST	Larry Dudas	TOTAL DEPTH OF HOLE	18.0 Feet
DRILL RIG	Hollow Stem Auger w/Split Spoon Sampler	WATER LEVEL	

Blows/6"	PID (ppm)	ID#/Recov %	DEPTH (ft)	SAMPLES	SYMBOLS	MATERIALS DESCRIPTION
						SAND: very coarse.
40/50-4"	28	60%	5			Decomposed granite: black, white, brown; feldspar, biotite, quartz; friable, <u>moderate petroleum odor</u> . Cuttings have very strong diesel odor from 5' to 7'.
87/6"	20	33%	10			Decomposed granite: black, white, brown; feldspar, biotite, quartz; friable, <u>very slight petroleum odor</u> .
120/4"	0					Decomposed granite: black, white, brown; feldspar, biotite, quartz; friable, no odor. Total Depth = 12.0' bgs.

PROJECT	March Air Force Base	DRILLING COMPANY	Tonto Environmental Drilling
LOCATION	IRP Site 35C, Bldg. 3406	DATE DRILLED	03/15/94
JOB NUMBER	722406.49040	SURFACE ELEVATION	
GEOLOGIST	Larry Dudas	TOTAL DEPTH OF HOLE	12.0 Feet
DRILL RIG	Hollow Stem Auger w/Split Spoon Sampler	WATER LEVEL	

Blows/6"	PID (ppm)	ID#/Recov %	DEPTH (ft)	SAMPLES	SYMBOLS	MATERIALS DESCRIPTION
						SAND: very coarse.
50-5"	0	33%	5			Decomposed granite: black brown, and white; feldspar, biotite, quartz; friable, no odor.
35/50-2"	0	50%				Decomposed granite: black brown, and white; feldspar, biotite, quartz; friable, no odor.
13/50	0	33%	10			Decomposed granite: black brown, and white; feldspar, quartz, increase in biotite; friable, no odor.
<i>Total Depth = 12.0' bgs.</i>						

PROJECT	March Air Force Base	DRILLING COMPANY	Tonto Environmental Drilling
LOCATION	IRP Site 35C, Bldg. 3406	DATE DRILLED	03/16/94
JOB NUMBER	722406.49040	SURFACE ELEVATION	
GEOLOGIST	Larry Dodus	TOTAL DEPTH OF HOLE	12 Feet
DRILL RIG	Hollow Stem Auger w/Split Spoon Sampler	WATER LEVEL	

Blows/6"	PID (ppm)	ID#/Recov %	DEPTH (ft)	SAMPLES	SYMBOLS	MATERIALS DESCRIPTION
						SAND: yellowish brown (10 YR 5/4) to brown (10 YR 5/8); very coarse, feldspar, quartz, mica.
15/30-4"	84	MA-2-VW-4 60%	5	☒		Decomposed granite: black and white, abundant mica; <u>moderate petroleum odor</u> . <u>Strong odor in cuttings from 5' to 7' bgs.</u>
36/50-2"	60	MA-2-VW-9 33%	10	☒		Decomposed granite: as above, <u>very slight petroleum odor</u> .
64/50-1"	0	MA-2-VW-14 33%	15	☒		Same as above, except no odor. <i>Total Depth = 14.0' bgs.</i>
			20			
			25			

PROJECT	March Air Force Base	DRILLING COMPANY	Tonto Environmental Drilling
LOCATION	IRP Site 35C, Bldg. 3406	DATE DRILLED	03/15/94
JOB NUMBER	722406.49040	SURFACE ELEVATION	
GEOLOGIST	Larry Dudas	TOTAL DEPTH OF HOLE	14.0 Feet
DRILL RIG	Hollow Stem Auger w/Split Spoon Sampler	WATER LEVEL	13.5 Feet

Blows/6"	PID (ppm)	ID#/Recov %	DEPTH (ft)	SAMPLES	SYMBOLS	MATERIALS DESCRIPTION
						SAND: very coarse.
30/50-4"	128	33%	5			Decomposed granite: black, brown, white; biotite, feldspar; friable, <u>very strong petroleum odor in cuttings.</u>
21/159	23	50%	10			Decomposed granite: black, brown, white; biotite, feldspar; friable, <u>slight petroleum odor.</u>
46/50-2"	0	33%				Decomposed granite: black, brown, white; biotite, feldspar; friable, damp, no odor. <i>Total Depth = 12.0' bgs.</i>
			15			
			20			
			25			

PROJECT	March Air Force Base	DRILLING COMPANY	Tonto Environmental Drilling
LOCATION	IRP Site 35C, Bldg. 3406	DATE DRILLED	03/15/94
JOB NUMBER	722406.49040	SURFACE ELEVATION	
GEOLOGIST	Larry Dudas	TOTAL DEPTH OF HOLE	12.0 Feet
DRILL RIG	Hollow Stem Auger w/Split Spoon Sampler	WATER LEVEL	

Blows/6"	PID (ppm)	ID#/Recov %	DEPTH (ft)	SAMPLES	SYMBOLS	MATERIALS DESCRIPTION
						SAND: very coarse.
40-62	0	66%	5			Decomposed granite: black, white, and light brown (7.5 YR 6/3); biotite, feldspar, quartz; friable, no odor.
50-6"	0	33%	10			Decomposed granite: as above, moist, no odor.
Total Depth = 12.0' bgs.						

PROJECT	March Air Force Base	DRILLING COMPANY	Tonto Environmental Drilling
LOCATION	IRP Site 35C, Bldg. 3406	DATE DRILLED	03/15/94
JOB NUMBER	722406.49040	SURFACE ELEVATION	
GEOLOGIST	Larry Dudas	TOTAL DEPTH OF HOLE	12.0 Feet
DRILL RIG	Hollow Stem Auger w/Split Spoon Sampler	WATER LEVEL	



AIR TOXICS LTD.
AN ENVIRONMENTAL ANALYTICAL LABORATORY

9403175

180 BLUE RAVINE ROAD, SUITE B
FOLSOM, CA 95630
(916) 985-1000 • FAX (916) 985-1020

CHAIN OF CUSTODY RECORD

Page 1 of 1

PROJECT # 722406.4908 PO # _____ COLLECTED BY (Signature) [Signature]
REMARKS _____

FIELD SAMPLE I.D.#	SAMPLING MEDIA (Tenax, Canister etc.)	DATE/TIME	ANALYSIS	VAC./PRESSURE	LAB I.D.#
MAH-MPC-4	CANISTER	3/18/94 1405	TVH 4 TO 3 (PEX)	3.0" H ₂ O	
MAH-MPB-7	"	3/18/94 1411	"	3.0" H ₂ O	
MAH-VW	"	3/18/94 1414	"	2.0" H ₂ O	

01A
02A
03A

RELINQUISHED BY: DATE/TIME _____ RECEIVED BY: DATE/TIME _____
LARRY DUDOS 3/21/94 0730 Wally (Wesley) Hart 3-22-94 9:55
 RECEIVED BY: DATE/TIME _____

LAB USE ONLY

SHIPPER NAME Fed-X AIR BILL # 8219521530 OPENED BY: DATE/TIME Wally 3/22/94 9:55 TEMP(°C) Room CONDITION Good
 REMARKS custody seals not present - PD 3/22/94

740317.503

CHAIN OF CUSTODY RECORD

PROJECT NO.	PROJECT NAME	NO. OF CONTAINERS	ANALYTICAL METHOD										REMARKS		
			SLD 9045 (04)	SLD 403 (LUAL)	SLD 7380 (REU)	SLD 846 (MAY)	SLD 8020 (LTPK)	SLD 1461 (TRM)	SLD 2512 (TRM)	SLD 3653 (TRM)	SLD 3653 (TRM)	SLD 3653 (TRM)			
DATE	TIME	MATRIX TYPE	SAMPLE I.D.												
2/5/94		SOIL	MA2-MPB-6	1	✓	✓	✓	✓	✓	✓	✓	✓	✓	✓	120 RPM FIELD RE-ADMS
			MA2-MPA-4	2	✓	✓	✓	✓	✓	✓	✓	✓	✓	✓	
			MPB-VW-01	1	✓	✓	✓	✓	✓	✓	✓	✓	✓	✓	
			MA2-MPA-9	1	✓	✓	✓	✓	✓	✓	✓	✓	✓	✓	
			MPA-VW-4	1	✓	✓	✓	✓	✓	✓	✓	✓	✓	✓	
			MA2-MPB-9	1	✓	✓	✓	✓	✓	✓	✓	✓	✓	✓	
			MA2-MPC-6	1	✓	✓	✓	✓	✓	✓	✓	✓	✓	✓	

RELINQUISHED BY (SIGNATURE)	DATE	RECEIVED BY (SIGNATURE)	DATE	PRESERVATIVES
	2/16/94		2/17/94	FOOD CONTAINER INSTANT
RELINQUISHED BY (SIGNATURE)	TIME	RECEIVED BY (SIGNATURE)	TIME	@ 2.6°C
	0730		10:10 AM	
RELINQUISHED BY (SIGNATURE)	DATE	RECEIVED BY (SIGNATURE)	DATE	SEND RESULTS TO:
				LARRY OUDS FES
RELINQUISHED BY (SIGNATURE)	TIME	RECEIVED BY (SIGNATURE)	TIME	CA
				DENVER

211.065600

ENGINEERING-SCIENCE, INC.

FFD FAX AIR BILL 82191524622