

REPORT DOCUMENTATION PAGE

Form Approved OMB No. 0704-0188

Public reporting burden for this collection of information is estimated to average 1 hour per response, including the time for reviewing instructions, searching existing data sources, gathering and maintaining the data needed, and completing and reviewing the collection of information. Send comments regarding this burden estimate or any other aspect of this collection of information, including suggestions for reducing this burden to Washington Headquarters Services, Directorate for Information Operations and Reports, 1215 Jefferson Davis Highway, Suite 1204, Arlington, VA 22202-4302, and to the Office of Management and Budget, Paperwork Reduction Project (0704-0188), Washington, DC 20503.

1. AGENCY USE ONLY (Leave blank)		2. REPORT DATE 2-August-2000	3. REPORT TYPE AND DATES COVERED Final Report	
4. TITLE AND SUBTITLE Adaptation Of Panoramic Annular Lens (PAL) To Some Military Video Systems			5. FUNDING NUMBERS F61775-99-WE065	
6. AUTHOR(S) Dr Pal Greguss				
7. PERFORMING ORGANIZATION NAME(S) AND ADDRESS(ES) OPTOPAL Panoramic Metrology Consulting Csiksomlyo u 4. Budapest H-1025 Hungary			8. PERFORMING ORGANIZATION REPORT NUMBER N/A	
9. SPONSORING/MONITORING AGENCY NAME(S) AND ADDRESS(ES) EOARD PSC 802 BOX 14 FPO 09499-0200			10. SPONSORING/MONITORING AGENCY REPORT NUMBER SPC 99-4065	
11. SUPPLEMENTARY NOTES				
12a. DISTRIBUTION/AVAILABILITY STATEMENT Approved for public release; distribution is unlimited.			12b. DISTRIBUTION CODE A	
13. ABSTRACT (Maximum 200 words) This report results from a contract tasking OPTOPAL Panoramic Metrology Consulting as follows: This investigation will consist of adaptation of a Hungarian-developed single-piece imaging block, the Panoramic Annular Lens (PAL) to a few military applications. A multipurpose breadboard platform will be constructed to test the optimized and realized optical sensor/vision modules, and check if they can cope with proposed tasks. Software will be developed to straighten out the annular image, i.e., to transform it to a rectangular frame showing the 360 degree panorama in a usual and correct vertical stance.				
14. SUBJECT TERMS EOARD, Optical Components, Optical Sensors			15. NUMBER OF PAGES 15	
			16. PRICE CODE N/A	
17. SECURITY CLASSIFICATION OF REPORT UNCLASSIFIED	18. SECURITY CLASSIFICATION OF THIS PAGE UNCLASSIFIED	19. SECURITY CLASSIFICATION OF ABSTRACT UNCLASSIFIED	20. LIMITATION OF ABSTRACT UL	

20010126 029

NSN 7540-01-280-5500

Standard Form 298 (Rev. 2-89)
Prescribed by ANSI Std. Z39-18
298-102

FINAL REPORT
of the Project SPC-99-4065, Contract Order No. F61775-99-WEO65

Introduction

This Project started on August 1, 1999, with the goal to find out, via a feasibility study, whether a centric minded imaging (CMI) block, the Panoramic Annular Lens (PAL) - similar to that which was used in the PAL Attitude Determination System (PALADS) of the micro-satellite SEDSAT-1 launched on October 24, 1998, - could be adapted to military video systems, such as

1. Azimuth determination system (ADS)
2. Sniper fire location display (SFLD)
3. Helicopter blade tracking system, (HBTS),

The assumption was that this can be achieved by re-designing the PAL, increasing its vertical viewing angle, and adding to the PAL-based vision system a humanoid "flair".

Theoretical basis of PAL

The main characteristics of any centric minded imaging (CMI) system is that it is in the center of the coordinate system that describes the three-dimensional scene, and not on its periphery, as in the case of conventional see-through-window (STW) imaging strategy.

In STW strategy, one "sees" the 3D world only through discrete chunks as if looking through a window by moving the head up and down or turning around. As a result, due to this effect of *frame phenomenon*, one cannot get full 3D information in real time. CMI based systems, however, because of their being in the center of the 3D space, totally eliminate this drawback of STW imaging. The most up-to-date CMI block is the Panoramic annular Lens (PAL)¹

PAL considers namely the visual field to be cylindrical, rather than spherical. The image of object points will then be projected first onto an imaginary cylinder wall that is located at a distance equal to the prevailing vision distance, and then, - using some mathematically well describable optical stretching maneuvers - this panoramic image projection will be transformed onto a plane perpendicular to the axis of the cylinder. (Fig. 1)

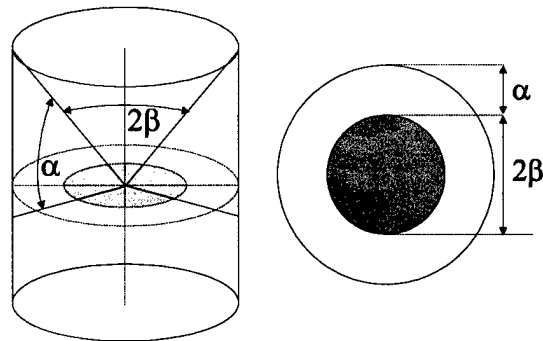

Fig.1. Principle of CMI

As a result, the whole 360° visual field - and not only a segment or a frame of the selected visual angle - will appear on the plane surface as an annular image, and the image points retain the same 1:1 relation of the original object points. The width of the ring will correspond to the vertical viewing angle of the PAL, while points on concentric rings will represent different horizontal spatial angles within a given vertical viewing angle. Thus, the two-dimensional skeleton of the three-dimensional world will be encoded in this annular image, which, at the first sight, looks like a cross section image as we are accustomed to, but it is not.

This leads also to the coding of the *appearance of depth* on a two-dimensional surface as a convergence into *one* point,

resulting in just one *single* vanishing point. For this 3D optical coding method, the term *Flat Cylinder Perspective (FCP) imaging* was introduced. Here the entire 360° panoramic space becomes visible at once, however, both the usual and the inverted perspective will appear simultaneously. This is why at the first glance one has difficulties to orient himself in this type of picture. However, using appropriate software, the ring shaped image can be „folded out” „straightened out”, i.e., the 360° panoramic image displayed in polar coordinates can be converted into Cartesian coordinates, and the mentioned discomfort immediately disappears.

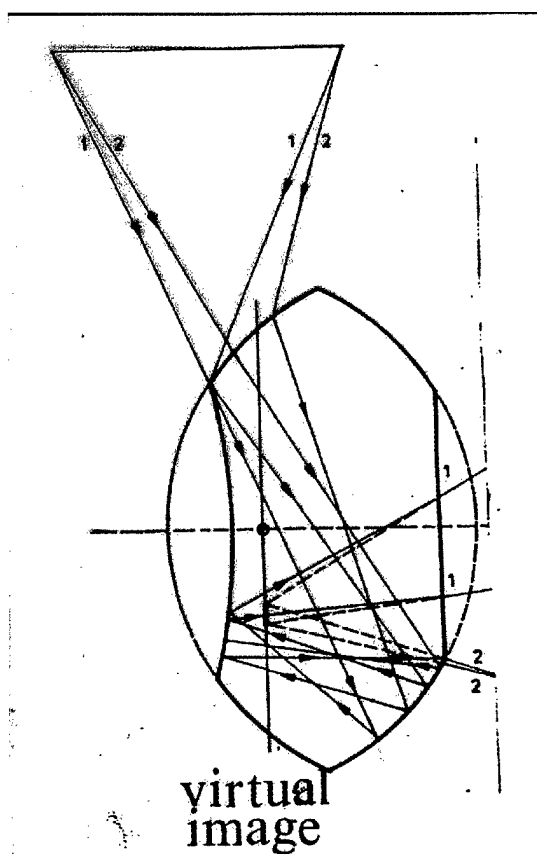

Fig. 2. Formation of a miniaturized image volume of the 3D space encircling the PAL.

One consequence of this type of CMI is that not a real but a *virtual* image is formed inside the PAL. Better to say, - as shown in Fig. 2, - a *virtual image volume*, which can be regarded as a *miniaturized* image volume of the 3D space encircling the imag-

ing block, and one can assume that it contains all the imaging point data from the real 3D space

Geometrical characteristics of PALs

A PAL can be considered to be basically of *catadioptric* type, since it consists of a single piece of glass that has two refractive and two reflective surfaces. This, however, means that the number of the possible shapes amounts to the number of the iterative variations of the 4th class that can be performed of three elements, i.e., to 81.

Some of these shapes, however, are more suitable for a given CMI task than others; further, the refractive index of the glass material used is also an image determining factor. Thus, practically for each sort of application a customized optical design is needed. To help to develop appropriate design programs, we have introduced the concept of the *standard* PAL.

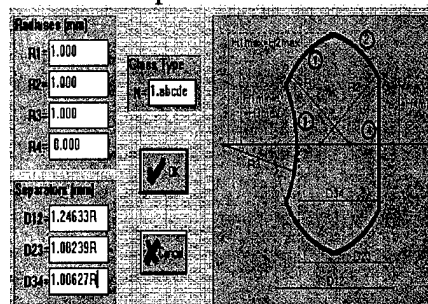

Fig. 3. Scheme of the standard PAL.
1 and 4 – refracting surfaces with antireflection coating
2 and 3 – reflecting surfaces

One characteristic of the standard PAL is that one can derive numerical values which, when multiplied with the radius of the best-fit sphere, provide the geometric parameters that permit to compare the various PAL designs. So, e.g.,

$$\begin{aligned} H1_{\max} &= H2_{\max} = 0.92388 R, \\ H1_{\min} &= H3_{\max} = 0.38268 R, \\ H2_{\min} &= H4_{\max} = 0.38268 R, \end{aligned}$$

where R is the radius of the best-fit sphere in question.

The simplest shape is where all the curved surfaces have the same radii, equal to the radii of the *best-fit spheres* for the aspherics that are needed for high-quality imaging. These radii were taken in the first design steps as unity.

The expression "*best-fit sphere*" is related to a sphere, which intersects the aspheric in question at the center and at the edge, and is sometimes referred to as "*envelope sphere*". Methods to calculate the best fit sphere have been reported.^{2,3} Perhaps the simplest routine would be to curvefit a circle to the aspheric in question in such a way as to minimize the square of the deviation of the circle from the aspheric curve.

In designing PAL optics, one way is to define the maximum distance between the best-fit sphere and the aspheric in question, called aspheric departure, Δ , which could be described approximately as

$$\Delta = D^4 / 4096 f^3$$

where D is the diameter of the PAL, and f is the focal length of the aspheric.

In the beginning of our investigations we thought that significant improvements in the imaging quality could be expected by changing at least one of the PAL surfaces "back to" aspherics. Starting from the reasoning that the sensitivity of an optic depends – among others – upon the ratio of the surface's radius of curvature to its diameter and that the first reflecting surface of PAL is the most sensitive out of the four surfaces to a change in conic constant, we were thinking to "go back" to aspherics at this surface.

Further, we gave thoughts also to the fact that one of the surfaces of PAL (the reflecting concave surface) can be considered to have an "*obstruction*" the best fit sphere has to be defined as the sphere that intersects the aspheric at the edge of the obstruction, and the outer edge of the PAL.

Our investigation so far, however, has not really supported the assumption that by the above mentioned means the performance of a PAL could be *significantly* improved; so, for the time being, we stopped our investigation in this direction, but we intend to go on with it if other requirements emerge.

Design considerations

To develop new PAL designs our first step was to compare the shape and material parameters of the PALs made so far with the data "recommended" by the "standard PAL" model, based on their imaging qualities. We tried to find out the meaning and cause of the differences we observed. The result of these investigations was that design of new shapes and glass material is needed, especially, if we wish to develop a humanoid version of PAL, i.e., a version which renders not only a 360° panoramic ring shaped image but also has a central, i.e. *foveal*, vision. This is especially important in developing the sniper fire location display (SFLD) and the helicopter blade tracking system (HBTS)

HMVS

The construction of a humanoid machine vision system version of a PAL is made possible by the fact that the central region around the optical axis of the PAL does not take part in forming the annular image. It allows only that the image forming rays travel from one surface to the other. Thus, if a lens-mirror combination is put in front of the PAL – after removing a portion of the reflecting coating of the concave surface around the optical axis in such a way that the image plane of this lens-mirror combination coincides with the virtual image plane inside the PAL, an image will be formed in the central region of the annular picture, which otherwise is black and contains no image information. Its role is similar to the foveal image in

human vision, and this is the reason why it is called Humanoid Machine Vision System.

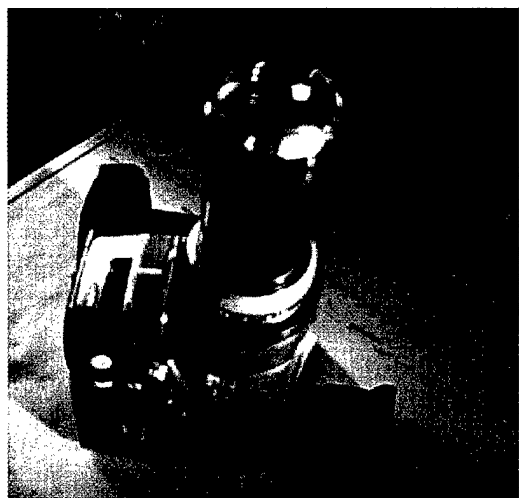

f:~25 mm



f:~18 mm

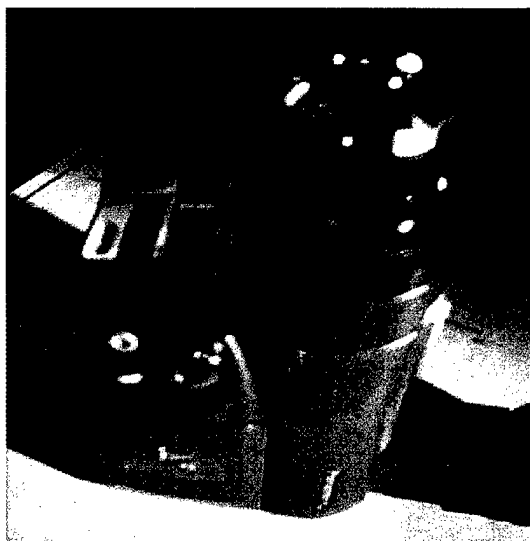

f: ~4 mm

Fig. 4. Various lengths of PAL mount

First of all, we had to determine the exact location of the virtual image plane *inside* the PAL, then, to find out those parameters of the foveal optic that permit to project this *real* image *exactly* to the center of the *virtual* image plane. This should be achieved in such a way that only a single relay lens is needed to project the panoramic and the foveal image onto the recording surface (CCD chip), which is not a simple task at all.

Preliminary data to find correlation between the focal length of the relay optic needed to project this "image complex" onto the image sensor showed, - as it can be seen in Fig. 4 - that the shorter the focal length the shorter the mount needed to couple the PAL to the image sensor, provided that neither the optical geometric parameters of the PAL-foveal assembly nor the image sensors change.

We wanted to use off-the-shelf optics for the task of relay lenses, however, it turned out that we are better off if we regard in our design the *PAL-foveal lens-relay lens* system as a *single unit*.

After having realized this, we started to design a HMVS that followed this concept. It turned out that the ZEMAX-EE program is not capable to handle directly these requirements. Fortunately, we have found a way to overcome this difficulty, and the result can be found in Appendix I.

This PAL - foveal lens - relay lens system is based on a PAL having a diameter of about 50 mm. (Fig. 5)

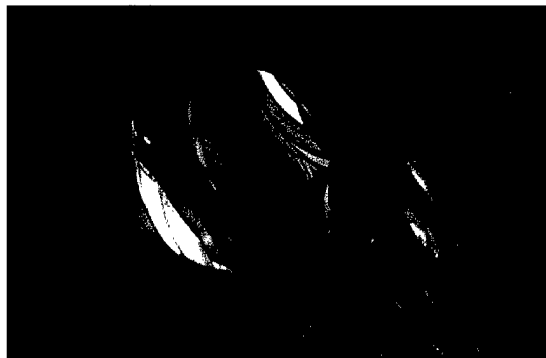

Fig. 5. PAL Ø50 mm. Please note that no coatings are on the PAL.

Although the imaging characteristics of this HMVS seem to be rather good, we think that before realizing it, a slight modification of the geometric parameters is advisable, not only to further improve the image performance but also to reduce the overall dimensions of the system. This is going to be not very easy, nevertheless, we already started to look more closely into this matter. The first tentative trials can be seen in Appendix II.

PALs for stereoscopic measurements

Another way of thinking and designing is needed when a vision module for stereopsis is considered. The idea to use PAL for this purpose is not new. The so-called PALIMADAR (PAL-based Imaging Module for All-round Data Acquisition and Recording) ⁴ was thought for stereoscopic measurements, however, these designs performed only horizontally: for vertical measurements they had to be turned around the optical axis of the system.

In our „Statement of Work” we expressed the idea to create a vision module where panoramic stereopsis can be formed without the need for turning. This would be based on the „ellipsoid-based” PAL concept, where two concentric panoramic images – one *virtual* and one *real* – are formed. Design of such a system could have the following steps

1. Let the F_2 focus be on the horizontal axis at a distance $2R/3$ to the right from the origo O of the Cartesian coordinate system, and a point M at the same distance to the left, R being the radius of the best-fit sphere of PAL. Let us draw a perpendicular to the horizontal axis in this point M , and at a distance $2R/3$ from point M will be the focal point F_1 of the ellipse.

2. The line connecting foci F_1 and F_2 will provide the major axis $2a$, and the point C where this intersects the vertical

axis of the Cartesian coordinate system will be the center of the ellipse.

3. The upper extreme points 1,2 of the optique will be obtained when a circle of radius R is drawn with point O as origo, and intersects the line drawn in point C parallel with the horizontal axis of the coordinate system.

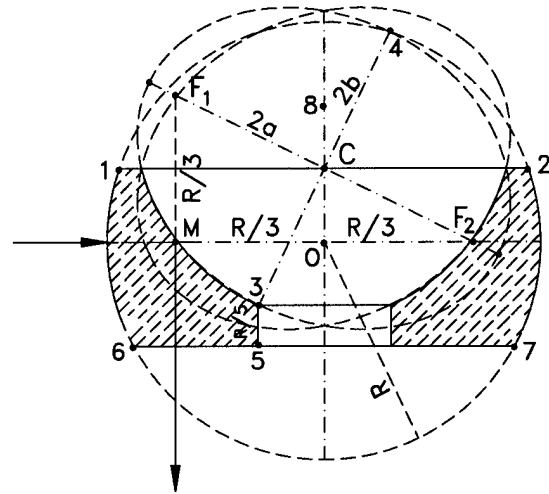

4. The extreme points 3,4 of the minor axis $2b$ of the ellipse are located at the points where circles of radius R drawn from points F_1 and F_2 , respectively, intersect the line drawn perpendicular to the major axis $2a$ in point C .

5. The lower extreme points 6,7 can be obtained by drawing a parallel line to the horizontal axis at a distance $R/5$ from the extreme point 3 of the minor axis.

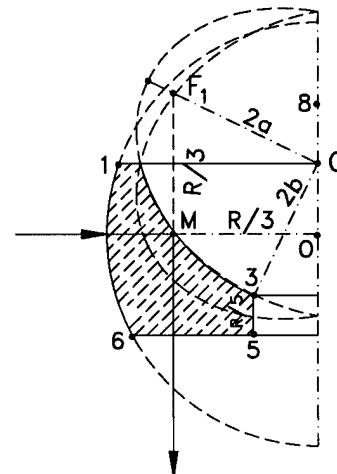

6. As a result of these construction steps the cross section of an optical element is obtained. Let us now rotate this

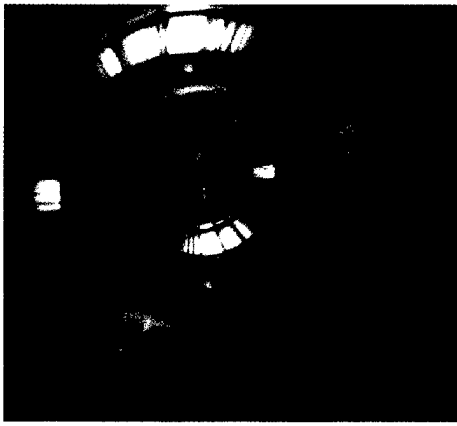

SATELLITE: a PAL image processing software

In our "Statement of Work" it was proposed to develop a software for straightening out the annular image, i.e., to transform it into Cartesian coordinates, which means to a rectangular frame showing the 360° panorama in the usual and correct vertical stance.

The SATELLITE software we have developed performs all these requirements and, in addition, it is suitable for various image processing tasks. The suffix Version 1.0 indicates our intention to expand in the future these capabilities for more sophisticated measurements in 3D environment.

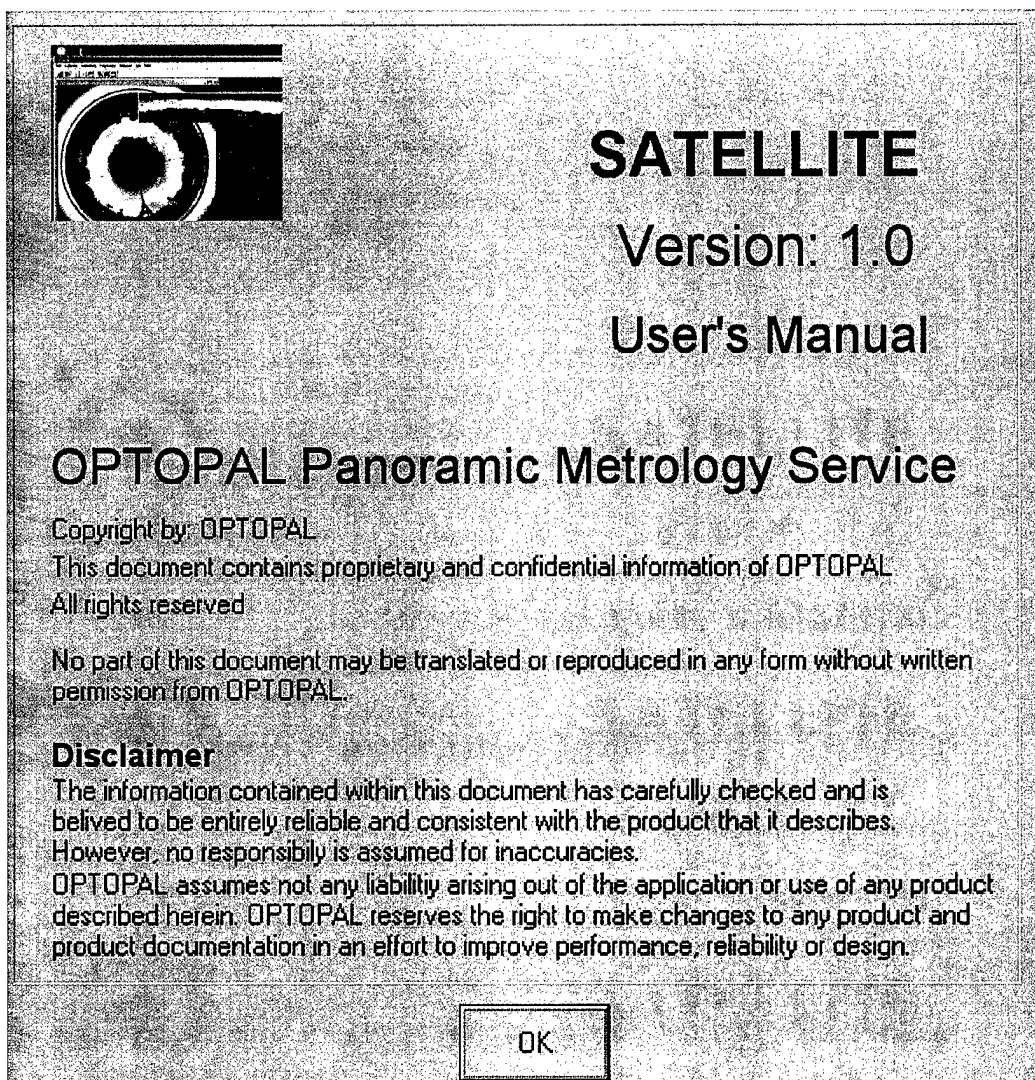

Our main goal was to create a software that can be used for various configurations consisting of PAL-optics, relay lens, and CCD, and this without the need for recalibration.

To achieve this, the calibration process contains the following steps:

Set angles, which means that the viewing angles above and below the horizon of the given PAL are stored;

Assign the upper viewing angle: point with the cursor arrow to the image point nearest to the center of the PAL image;

Assign the lower viewing angle: point with the cursor arrow to the image point that is at the rim of the PAL picture.

Assign the center point: point with the cursor arrow at the center of the black spot inside the PAL image by using the x and y

coordinate data displayed on the bottom of the screen.

If once the data are stored, in any panoramic image delivered by the actual PAL-relay lens-CCD configuration, the circle of the horizon can be displayed in a selected color.

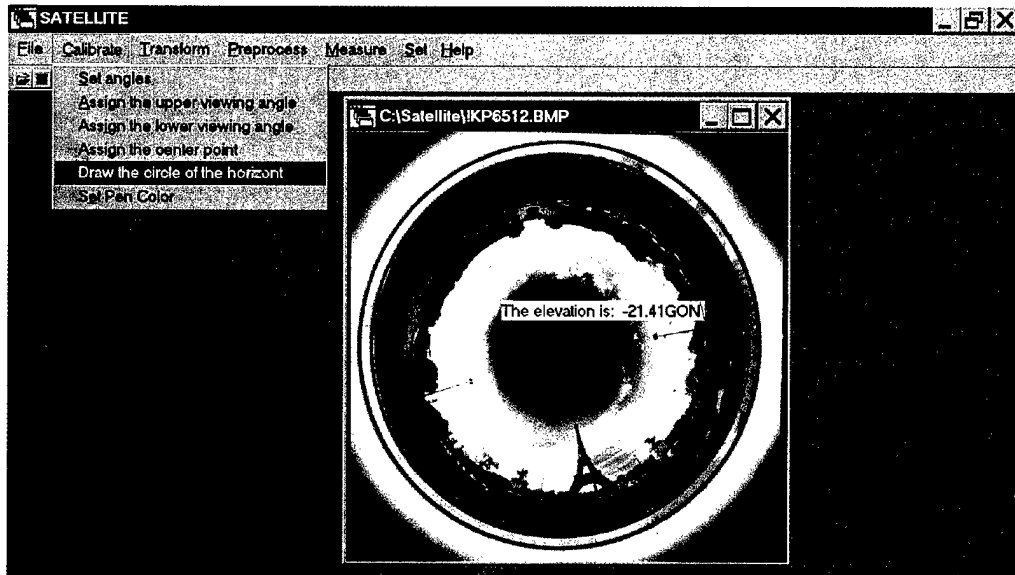

To “unwarp”, to “straighten out”, the option “TRANSFORM” from the toolbar has to be used, and then you can choose, from which direction the unwarping should start.

Clicking on the “SPLIT” option will result in two rectangular images giving you an idea what you would see at your left and right hand side when looking in the direction where unwarping started.

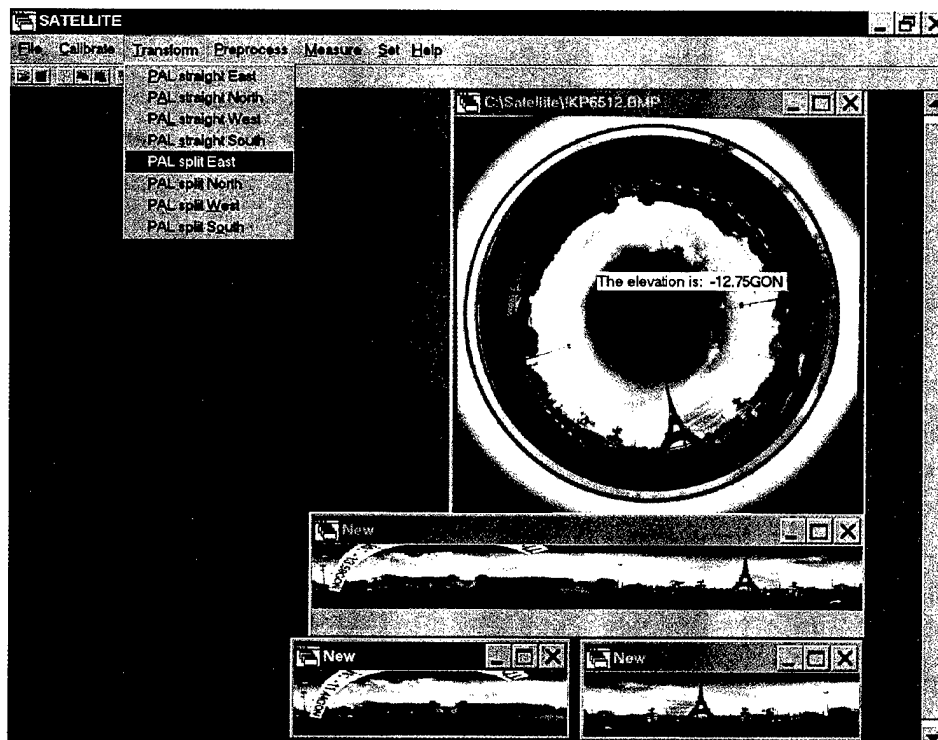

Processing is always more precise and easier when it is performed in gray scale, rather than in colors. The program offers the option to switch to gray scale by clicking on "Preprocess" on the toolbar. At present, one has the option to use various filters, further, to subtract, add, multiply, divide two image data.

Version 1.0 will handle in the future various measurements, e.g., distance assessment, etc.

These are based on the already mentioned characteristics of the PAL namely, that the width of the resulting annulus represents the viewing angle of the PAL in its optical axis, thus, each pixel along the radii of the projected annular image represents the direction of an object point in space,

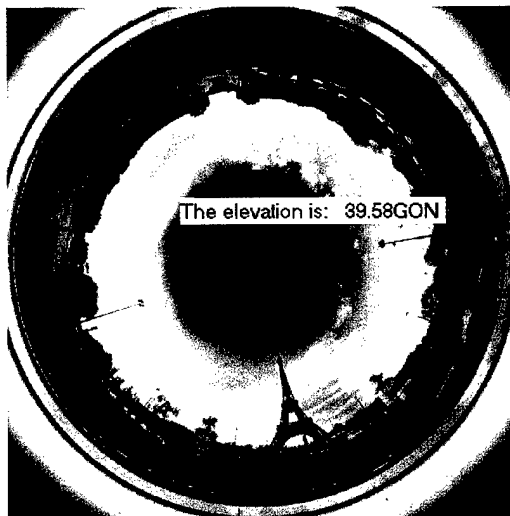

Fig. 6. Displaying the elevation of the top of the Eiffel tower in GON units (left) and showing on the map the place from where this PAL picture was recorded (point P on the map, right)

To rectify the panoramic ring shaped image, *anamorphic* method can be used. Either a mirror cylinder is placed vertically on the center of the annular picture or, with the aid of the CorelDraw 7.0 software, a virtual mirror cylinder displays the rectified version of the panoramic view – as shown in Fig. 7. Both techniques can be used to test the performance of the PAL: radial lines show up as vertical rods.

i.e., the azimuth value of this object point can be obtained quantitatively.

To demonstrate the steps of functioning of our SATELLITE software we have chosen a panoramic image recorded in Paris, because it contains objects of various heights, among others, the Eiffel Tower.

If we touch with the cursor arrow the top of the Eiffel tower, it prints out immediately the elevation value, i.e., the angle value above the PAL's horizon. (Just to remember: horizon is the plane where the spherical surfaces intersect)

Since the height of the Eiffel Tower is known (352 m), it is not too difficult to calculate the distance from where the picture was shot, because the azimuth angle is numerically displayed. (Fig. 6)

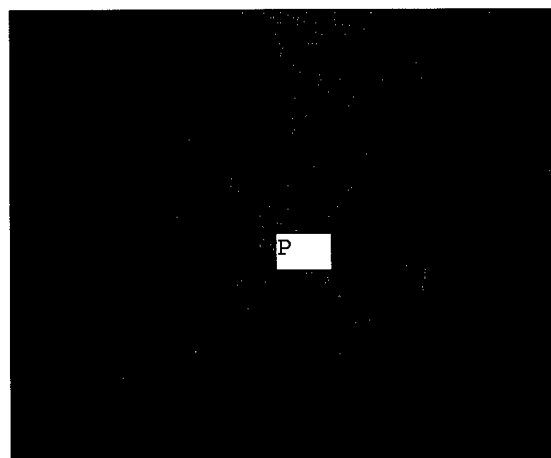

Azimuth determination system (ADS)

The proposed azimuth determination system is based in part on the SATELLITE 1.0 software, which allows us to define the direction of any object point in space. We showed previously that PAL allows direct distance measurement of an object if one knows its height. Distance can also be measured without knowing the height of the object, only so-called structured light illumination is needed. Let us illuminate the object in question with structured light (laser beam), then, for an illuminated object point below the horizon of the optic,

$$h_1 = R \operatorname{tg} \alpha_1,$$

and for an object point above the horizon of the optic,

$$h_2 = R \operatorname{tg} \alpha_2.$$

where R is the distance of the object point from the optical axis. It is known that in an annular image delivered by PAL radial lines mean lines in space parallel to its optical axis. On the other hand, the distance of the plane of the structured light from the plane of the optical horizon (h_1 and h_2) is known, the prevailing distance of the illuminated object point (object) from the optical axis can easily be determined. (Fig.

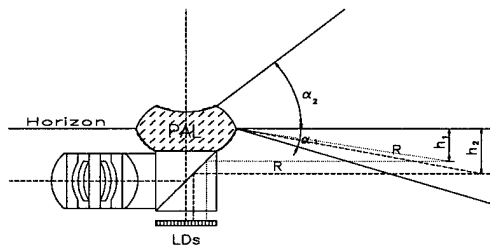

8)

Fig. 8. Principle of azimuth determination.

It follows from the fact that points at equal distances from the optical axis of PAL lie on the same circle in the ring

image, range-imaging strategies can be worked out.

Sniper fire location display (SFLD)

The sniper fire location display proposed is based on a PAL that has a central, so-called foveal vision too, i.e., it is a Humanoid Machine Vision System (HMVS). Combining HMVS with a rotating mirror, a selected scene of the panoramic image can be projected into the center of the annulus, even with magnification. This means that a sniper fire, which suddenly glares up somewhere in the 360° peripheral panoramic annular image, can be displayed simultaneously in the center of the annulus, so that it can be located.

For our preliminary experiments we have modified one of our existing PALs by removing a portion of the reflecting layer on the concave surface, as shown in Fig. 9.

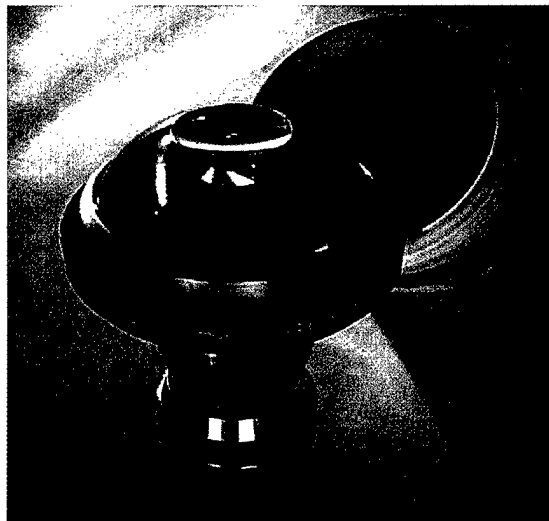

Fig.9. Modified PAL with foveal vision

The first experiments showed that the idea is working, however, the quality of the foveal image was rather poor (Fig. 10)

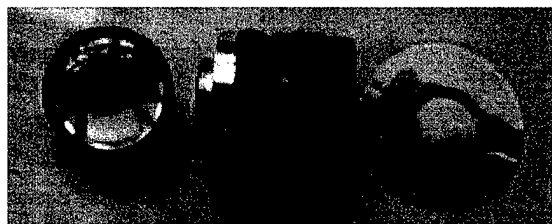

Fig. 10. Foveal image in the center of PAL

After having realized this we started to re-design the PALs using the ZEMAX-EE program, which allows creation of foveal image with higher quality. The result can be found in Appendix I.

Among the requirements for SFLD there is a measure of the speed of the movement of the observed object point. First, we thought to couple the PAL image through a rotating dove prism to a linear CCD consisting of 5000 pixels of the size $7\ \mu\text{m}$ by $7\ \mu\text{m}$. This would mean that in each turn of the prism the entire ring image surface will be swept over twice, each time with a resolution of $1.57 \cdot 10^8$ pixels. Since the rotation speed of the prism is known, the speed of the movement of the observed object point could be calculated with an appropriately designed software.

It turned out, however, that - in spite of the fact that this method offered very high resolution - very severe hardware problems had to be solved, which seemed to be not in balance with the resolution one could obtain.

Thus, we concluded to abandon - at least for the time being- this version of solution, and try to exploit the advanced properties of the cellular neural network CNN focal plane array processor chip, although its pixel number is only 64 by 64.

Consulting with the team of *AnaLogic Computers, Ltd.*, we decided to further pursue this idea and apply for a joint Special Project Contract to carry out calculations and investigation in more detail. We hope that this would lead us to a solution that could be put into practical application.

SFLD would really be useful when it could be combined with a head display. To demonstrate the idea we had in mind we put on the top of a helmet a PAL that was coupled to a board camera placed inside the helmet, and displayed the resulting panoramic image on the Personal Monitor of ALBACOMP. It weighs only 36 grams

and can be mounted on any eyeglasses. (Fig. 11) The PAL image appears in the person's line of sight in a viewing angle comparable to a viewing of a 61 cm monitor from about 2 m away.

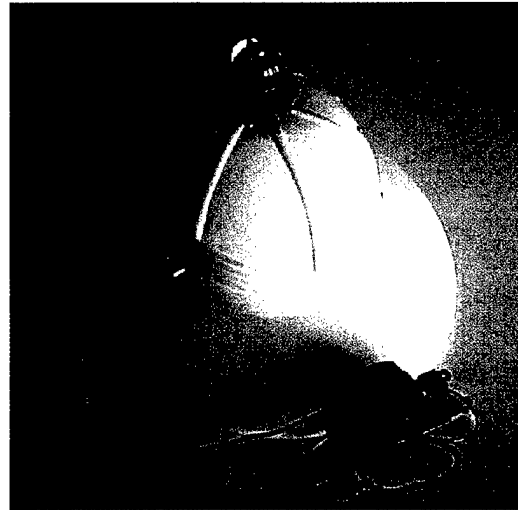

Fig. 11. Breadboard model for PAL-based SFLD with ALBACOMP Personal Monitor.

Although similar personal monitors are available on the market, this ALBACOMP product has the advantage that the video image is seen around, it covers only the area where the image appears, otherwise *users are free to view the surrounding environment*. This means that a constantly available image is in the person's line of sight, it enables to maintain focus and attention, it keeps the integrity of the surrounding environment. (Fig. 12)



Fig. 12. Person wearing helmet equipped with eye-glass-mounted Personal Monitor combined with PAL

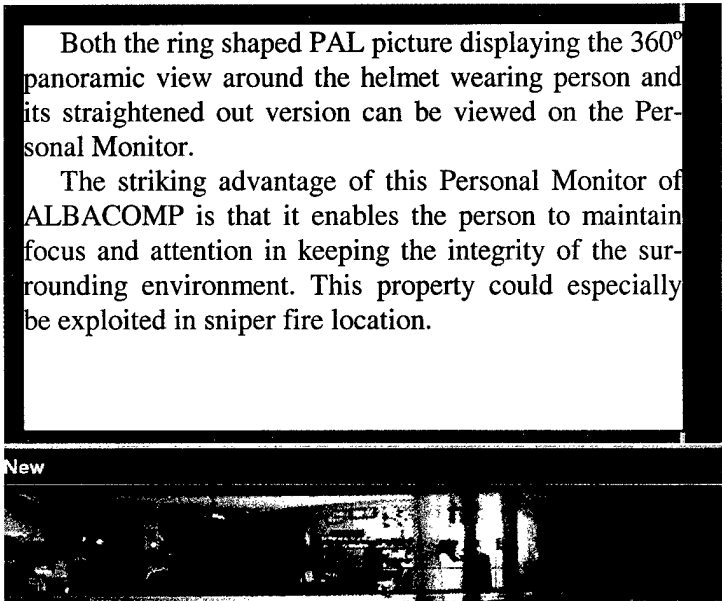

Fig. 13. What the person of Fig. 12.sees.

Helicopter Blade Tracking System (HBTS)

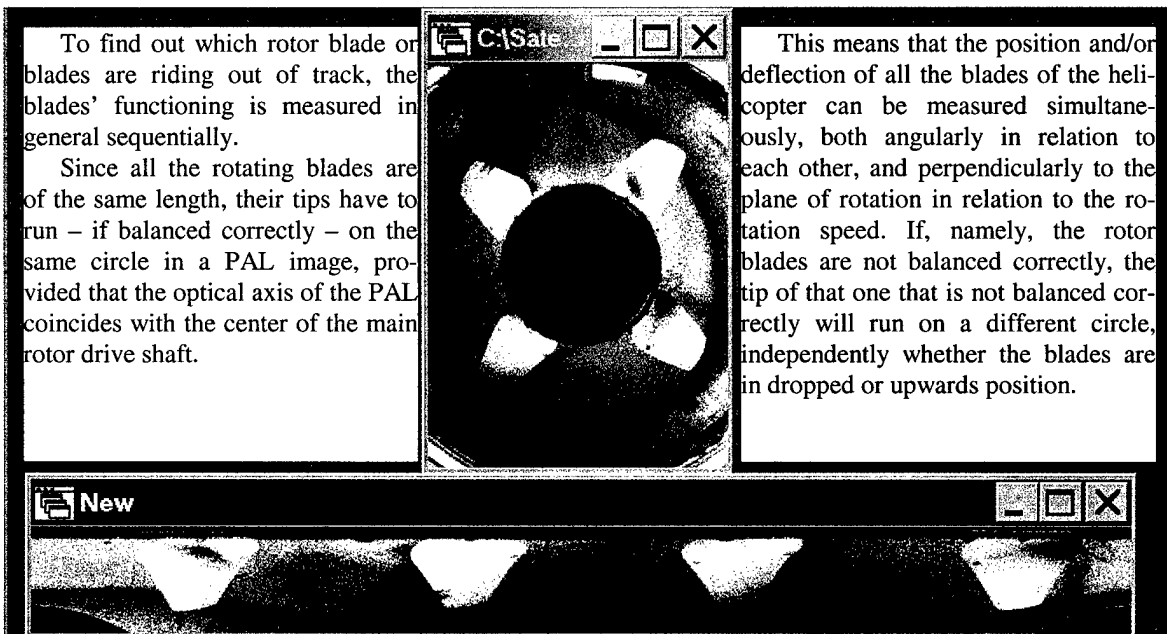

Fig. 14. PAL-image of a rotating ceiling fan's blades, and its straightened out version. Please remember that what a PAL-image shows is not a cross section, it is rather the two-dimensional skeleton of the 3D space. As a consequence, the amount of twist of each blade can also be observed

To check the validity of our assumption that a PAL-based measuring system could be developed for helicopter blade tracking, - which could be used even during flight - we have shot some PAL pictures from a rotating ceiling fan, the result of which can be seen above. These pictures clearly

showed that there is a crucial factor: the optical axis of the PAL should strictly coincide with the axis of rotation of the blades.

Discussions on this idea and our findings with helicopter experts of the Hun-

garian Air Force resulted in some non-

The first problem we are facing is to find the place on the helicopter where the CCD equipped PAL should be put, and find the way, how to fix it so that the optical axis of the PAL coincide with the rotation axis of the blades. This should be accomplished in such a way that this relation remains constant, even if unavoidable vibrations occur. Looking at the left side of Fig. 15, one must realize that it is not an easy engineering task. During our discussions it turned out that

expected answers to the problems outlined. Helicopter pilots are less interested in knowing, what extent the rotating blades are going out of track; they desperately want to know exactly the *moment for each blade* when they *start* to go out of track. The signal that this event is close manifests itself in a very low amplitude vibration of the tips of the blades. This gave us the idea to let rotate the PAL-equipped camera, instead of fixing it, thus, the image on the monitor will show each blade in such a way if they would stand still.

Fig. 15. Lay out of a helicopter rotary shaft.

At the same time, however, any motion of the tip of the blade can be not only visualized but also measured with an accuracy depending upon the resolution of the CCD used.

The advantage of this solution is that it is easier to find the place for the PAL-equipped board camera. Namely, below the closing cap of the rotary shaft – as shown on the right side of fig. 15 - there is enough room, and the requirements for keeping the axes in one straight line can also be fulfilled with great accuracy.

Preliminary experiments in this regard are about starting.

References

1. Greguss, P. Hung. Pat. 192125, USA Pat. 4566763, Japan Pat. 1962784, German Pat. 3402847, French Pat. 2540642., (1983)
2. Theodore, W., Unti, J.: "Best-fit-sphere approximation to a general aspheric surface", Applied Optics 5 No.2., 319-321, 1966.
3. Briers, J. D.: "Best-fit-spheres and conics as an aid in the manufacture and testing of diamond turned aspheric optics" Optica Acta 32, No.2., 169-178, 1985.

4. Greguss, P., Kertész, A., Kertész, V.:
"PALIMADAR - A PAL-optic based imaging
modul for allround data acquisition and recording"
In: "Applications of Digital Image Processing XV",
(Ed. Andrew G. Tescher), Proc. SPIE Vol.
1771:567-573, 1993 (San Diego, July 19-24,
1992).