

REPORT DOCUMENTATION PAGE			Form Approved OMB NO. 0704-0188	
Public reporting burden for this collection of information is estimated to average 1 hour per response, including the time for reviewing instructions, searching existing data sources, gathering and maintaining the data needed, and completing and reviewing the collection of information. Send comment regarding this burden estimate or any other aspect of this collection of information, including suggestions for reducing this burden, to Washington Headquarters Services, Directorate for Information Operations and Reports, 1215 Jefferson Davis Highway, Suite 1204, Arlington, VA 22202-4302, and to the Office of Management and Budget, Paperwork Reduction Project (0704-0188), Washington, DC 20503.				
1. AGENCY USE ONLY (Leave blank)	2. REPORT DATE 16 October 2000	3. REPORT TYPE AND DATES COVERED Final 4/17/00 – 10/16/00		
4. TITLE AND SUBTITLE Development of TMI Logistic Fuel Solid Oxide Fuel Cells (SOFC) for Military Auxiliary Power (Generation) Unit (APU)			5. FUNDING NUMBERS DAAD19-00-C-0088	
6. AUTHOR(S) Dr. Christopher E. Milliken, Group Leader Dr. Robert C. Ruhl, Vice President, Technology Michael Petrik, Vice President				
7. PERFORMING ORGANIZATION NAME(S) AND ADDRESS(ES) Technology Management, Inc. 9718 Lake Shore Boulevard Cleveland, OH 44108 Phone/Fax: 216-541-1000			8. PERFORMING ORGANIZATION REPORT NUMBER F0088	
9. SPONSORING / MONITORING AGENCY NAME(S) AND ADDRESS(ES) U.S. Army Research Office P.O. Box 12211 Research Triangle Park, NC 27709-2211			10. SPONSORING / MONITORING AGENCY REPORT NUMBER ARO41238.1-CH	
11. SUPPLEMENTARY NOTES The views, opinions and/or findings contained in this report are those of the author(s) and should not be construed as an official Department of the Army position, policy or decision, unless so designated by other documentation.				
12a. DISTRIBUTION / AVAILABILITY STATEMENT Approved for public release; distribution unlimited.			12 b. DISTRIBUTION CODE 20010227 138	
13. ABSTRACT (Maximum 200 words) A stand-alone interim program was proposed by Technology Management, Inc. (TMI), to characterize the state-of-the-art TMI solid oxide fuel cell <i>single cell</i> design and materials under a range of syngas sulfur levels up to those found in reformed JP-8 (0.3 wt% sulfur) over a range of operating conditions. The results of this interim program were inconclusive because of contamination introduced into the testing equipment, which was not uncovered until late in the study. Specifically, trace contaminants, not identified in the manufacture's specifications, in the premixed syngas mixture were found to react with the gaseous hydrogen sulfur prior to introduction to the cell. Together, these reactants produced a solid product wherever the temperature was elevated causing blockages that formed random deposits in regions of the fuel delivery manifold. These reaction products resulted in inaccurate measurement and/or delivery of syngas to the cells. Inaccurate fuel flow rates compromised test interpretation and data analysis. TMI was able to reaffirm sulfur tolerance in some tests but was unable to accumulate the definitive test data sought during this short six-month interim program.				
14. SUBJECT TERMS Solid oxide fuel cell, logistic fuel, sulfur tolerance			15. NUMBER OF PAGES 19	
			16. PRICE CODE	
17. SECURITY CLASSIFICATION OF REPORT UNCLASSIFIED	18. SECURITY CLASSIFICATION OF THIS PAGE UNCLASSIFIED	19. SECURITY CLASSIFICATION OF ABSTRACT UNCLASSIFIED	20. LIMITATION OF ABSTRACT UL	

Final Report

Development of TMI Logistic Fuel Solid Oxide Fuel Cells (SOFC) for Military Auxiliary Power (Generation) Unit (APU)

Contract number: DAAD19-00-C-0088

Contractor Name: Technology Management, Inc.
Contractor Address: 9718 Lake Shore Boulevard
Cleveland, OH 44108
Phone/Fax: 216-541-1000
tmi@stratos.net
(small business)

Authors: Dr. Christopher E. Milliken, Group Leader
Dr. Robert C. Ruhl, Vice President, Technology
Michael Petrik, Vice President

October 16, 2000

Limited Rights

Contract number: DAAD19-00-C-0088
Contractor Name: Technology Management, Inc.
Contractor Address: 9718 Lake Shore Boulevard
Cleveland, OH 44108

The Government's rights to use, modify, reproduce, release, perform, display, or disclose these technical data are restricted by paragraph C.3 of the Technical Data Rights clause contained in the above identified contract. Any reproduction of technical data or portions thereof marked with this legend must also reproduce the markings. Any person, other than the Government, who has been provided access to such data must promptly notify the above named Contractor.

(End of Legend)

Foreword

Since 1995 Technology Management, Inc. has tested a range of common hydrocarbon fuels for compatibility with its proprietary solid oxide fuel cell (SOFC). Under DARPA funding, these have included testing of sulfur-tolerant anode materials under a variety of conditions. A stand-alone interim program was proposed to characterize the TMI state-of-the-art SOFC *single cell* design and materials under a range of syngas sulfur levels up to those found in reformed JP-8 (0.3 wt% sulfur) over a range of conditions. This report summarizes only the stand-alone program although some details of the full five year program are referenced herein. The results of this interim program were inconclusive because of contamination introduced into the testing equipment which was not uncovered until late in the study. Specifically, trace contaminants, not identified in the manufacture's specifications, in the premixed syngas mixture were found to react with the gaseous hydrogen sulfur prior to introduction to the cell. Together, these reactants produced a solid product wherever the temperature was elevated causing blockages that formed random deposits in regions of the fuel delivery manifold. These reaction products resulted in inaccurate measurement and/or delivery of syngas to the cells. Inaccurate fuel flow rates compromised test interpretation and data analysis. Technology Management, Inc. was able to reaffirm sulfur tolerance in some tests but was unable to accumulate the definitive test data sought during this short (6) month interim program.

Table of Contents

Cover Page

Table of Contents.....	2
1.0 Technical Summary	4
1.1 Overall Program Objective	4
2.0 Background Information.....	4
2.1 TMI Power Generation Technology	5
2.2 Experimental Setup and Conditions.....	7
3.0 Results of Task Work.....	9
3.1 Reactor Stability and Contamination	9
3.2 Alternative Anode Compositions.....	17
3.3 Task 2. Evaluation of Sulfur Tolerance in Short Stacks	17
4.0 Conclusions.....	17
5.0 Recommendations for Future Work.....	18

List of Figures

Page

Figure 1. TMI SOFC Cell with Flows.....5

Figure 2. Typical PEM vs. TMI SOFC Logistic Fuel Flowsheets.6

Figure 3. Typical PEM vs. TMI SOFC Logistic Fuel Flowsheets.6

Figure 4. Test System Schematic.7

Figure 5. SEM and Optical Microscopy on Tube Residue.9

Figure 6. Cell Performance on Syngas + 150 ppm H₂S..... 11

Figure 7. Cell performance on 39% H₂O and sulfur bearing syngas
(150 and 300 ppm sulfur, 200 mA/cm² current density). 13

Figure 8. Reversible Experiments on 150 ppm sulfur bearing syngas (200 mA/cm²) 13

Figure 9. Anode microstructure after exposed to sulfur-bearing syngas (low degradation). 14

Figure 10. Agglomeration of and separation of metallic phase in the anode cermet..... 15

Figure 11. Manganese contamination “crystals” on anode surface. 15

Figure 12. High magnification image of manganese contamination (point D)
in primary ink anode layer..... 16

List of Tables

Page

Table 1. Primary Test Conditions.. 8

Table 2. Secondary Testing Conditions..... 8

1.0 Technical Summary

Solid oxide fuel cells (SOFCs) are power generation devices capable of operation over a wide range of operating conditions on various fuels. A proprietary feature of the Technology Management, Inc. SOFC is its tolerance to sulfur, a known poison to many other fuel cells. This unique operating feature permits the use of the TMI fuel cell in those situations where cleanup of available fuels is neither practical nor possible, such as under current military or emergency conditions. *Two equally important enabling developments should be mentioned: an integrated reactor design and a sulfur tolerant fuel reforming catalyst, both of which simplify the use of common fuels. In previous work funded by DARPA/ARO, TMI successfully tested anode materials, fuel reformers, and integrated systems under a variety of conditions including sulfur containing gasses such as $H_2 + 300 \text{ ppm } H_2S$ in single cells and reformed JP-8 with 0.3 wt% S in stacks.^[1]* The anode material tests, however, were not isolated discretely and operating conditions were not widely varied. Further, these tests were not characterized on syngas (representative of reformed JP-8). To help demonstrate that stack scale-up and operation of a TMI prototype system was achievable, an interim program was proposed to characterize state of the art cell design and materials under a range of syngas sulfur levels up to that found in reformed JP-8 (0.3 wt% sulfur) over a range of operating conditions.

During this six (6) month program, tests were conducted showing anode tolerance to sulfur exposure. Experimental complications arose, however, that precluded definitive testing. Trace contaminants found in bottled carbon monoxide were found to react with H_2S in the mixed syngas. Specifically, iron pentacarbonyl (and the nickel analog) reacted to form solid iron and nickel sulfide deposits in regions of the fuel delivery manifold that corrupted the test results. The difficult nature of the proposed experiments is discussed below. While definitive conclusions were not possible due to the impact of the contamination on test systems, the data still supports a degree of sulfur tolerance acceptable for most applications.

1.1 Overall Program Objective

Two stack issues are of central concern: 1) sulfur tolerance and 2) degradation including both short term (catastrophic) and long term (steady state) mechanisms. The experimental challenge is to approximate actual cell operating conditions without complicating the setup by adding a full-sized stack or reformer/vaporizer. The approach selected was to test single cells and small stacks using 'pre-reformed' syngas products (i.e., mixtures of $CO / CO_2 / H_2 / H_2O$ in the proper ratios) in a simple resistance controlled furnace. Tests were designed to simulate large stack conditions over a wide range of conditions.

2.0 Background Information

SOFCs use a solid electrolyte operating at high temperature (800-1000°C) to electrochemically convert gaseous fuels (hydrogen or mixed gases) and oxygen to electricity. Unlike polymer electrolyte membrane (PEM) fuel cells and alkaline fuel cells, SOFCs do not require electrolyte management (since the electrolyte is solid), have very fast electrode kinetics, and are generally

[1] "Solid Oxide Fuel Cell (SOFC) Powered Mobile Electric Power System," DARPA contract DAAH04-94-C-0015, June, 1999

resistant to fuel-contaminants such as CO. SOFCs are potentially very reliable, compact, and quiet. They can produce a high-grade heat by-product and have high system efficiencies.

2.1 TMI Power Generation Technology

Solid Oxide Fuel Cells (SOFCs) use an environmentally clean, electrochemical (non-combustion) process to generate electric power from a variety of fuels. SOFCs utilize a solid electrolyte operating at high

temperature (800-1000°C) to electrochemically convert gaseous fuels (hydrogen or mixed gases) and oxygen to electricity. Further, the combination of high operation temperature and solid state operation means that the TMI SOFC can potentially be very reliable, compact, and noiseless. Figure 1 shows an expanded schematic to illustrate the TMI SOFC single cell with conventional SOFC materials.

Each cell is made up of four layers: (1) a fused, porous, reticulated cermet anode that provides both fuel gas distribution and electrical continuity; (2) a pre-sintered, non-porous, yttria-stabilized zirconia (YSZ) electrolyte for selective ion conduction; (3) a fused, porous, reticulated ceramic cathode (LSM) that provides air distribution and electrical continuity; and (4) a dense, high-temperature metallic alloy separator for bipolar electrical conduction from cell to cell.

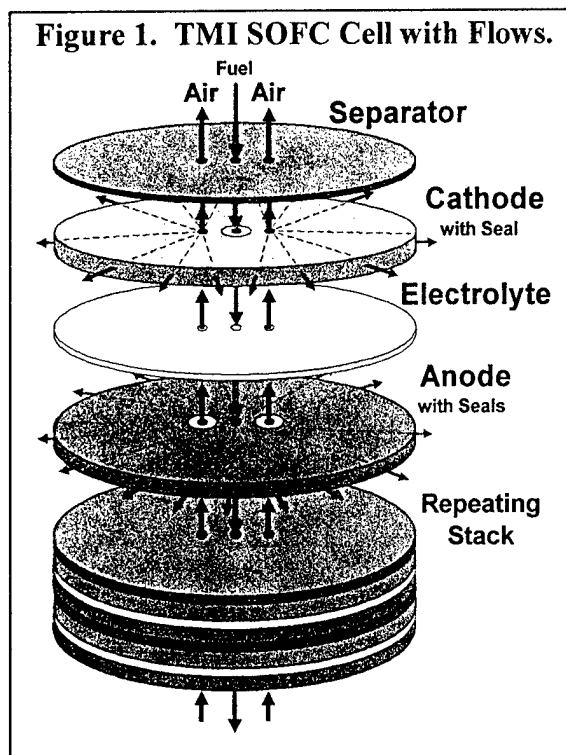

The TMI cell design has several advantages. The simple radial design utilizes an unconstrained perimeter that minimizes thermal expansion matching required by many other SOFC designs and allows for the incorporation of new or improved materials that are not feasible in cofired designs. The very simple, radial planar, non-featured cell components *provide manufacturing flexibility by allowing the use of commercially available, high volume automated manufacturing technologies.* The ability to produce the TMI SOFC at low unit cost is critical to achieving success in civilian commercial markets.

Another demonstrated advantage of the TMI SOFC cell and systems design is its ability to use a wide variety of fuels, particularly those containing sulfur contaminants, such as odorized natural gas and military fuels. Under sponsorship by DARPA (Defense Advanced Research Projects Agency), TMI was one of the first companies to operate a complete sulfur-tolerant system (with an integrated fuel reformer and stack) demonstrating operation of a total solid oxide fuel cell system operating on JP-8 fuel without sulfur-removal or fuel pretreatment. Sulfur tolerance affords many advantages including system simplicity, fuel flexibility, and environmental impact which directly relate to system size, weight, and cost. Figure 2 shows a typical fuel-processing schematic comparison for a TMI SOFC and a typical polymer-electrolyte fuel cell system.

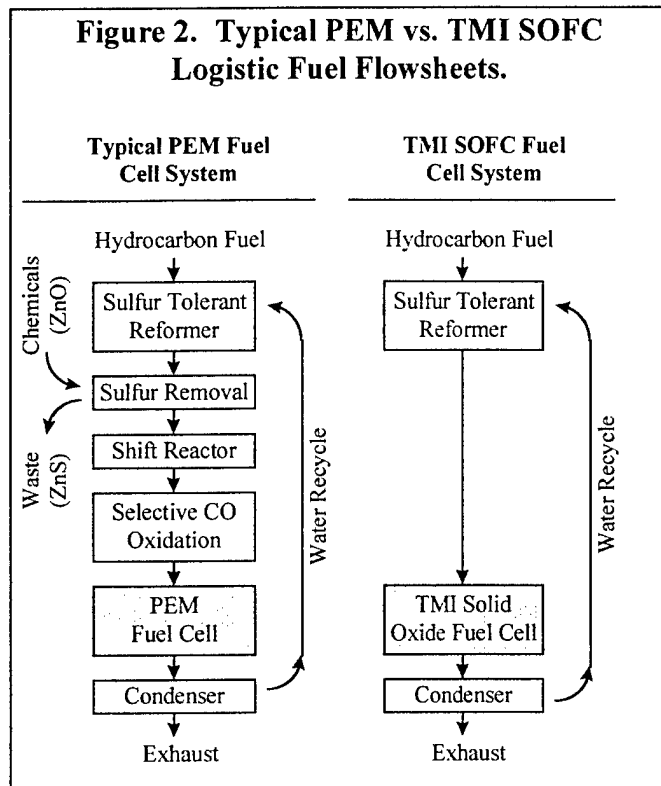

TMI's overall fuel cell system among the smallest and lightest known for a complete system operating on common fuels. An operational mock-up for use with natural gas is shown in Figure 3. The heart of the system is an integrated fuel reformer/fuel cell stack which is designed for automated low cost manufacture and operation.

Figure 3. Small Scale Integrated Laboratory Demonstration SOFC Generator

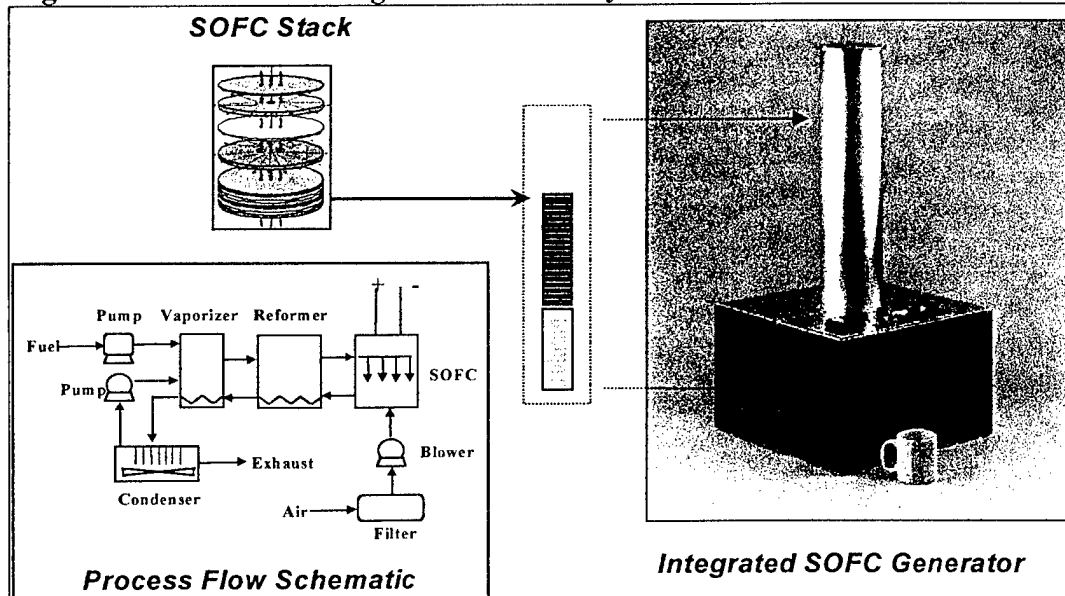

2.2 Experimental Setup and Conditions

Technology Management, Inc. has repeatedly shown experimental evidence that its primary anode material is tolerant to sulfur at operating temperature. However, these experimental laboratory conditions were not *exactly* equivalent to some conditions encountered in an actual device. The early single cell tests lacked carbonaceous reformat products (i.e., CO and CO₂) and were not verified over a range of potential operating conditions. To complete the evaluation of sulfur tolerance, tests were conducted on sulfur-containing syngas products. These tests included a range of practical operating conditions including:

- ◆ sulfur content (up to 300 ppm H₂S equivalent)
- ◆ current density
- ◆ fuel utilization

A schematic of the test reactor system is shown in Figure 4. Baseline performance was established for each test using H₂/N₂ + 6% H₂O in this reactor before switching to syngas. A fuel mixing manifold was used to obtain a range of H₂S containing syngas fuels. The dry syngas consisted of ~ 70% H₂, 20% CO, 10% CO₂ and 400 ppm H₂S and was metered through a multi-stage regulator system into a heated humidifier. The humidifier allowed the gas to flow through a constant temperature water column. Water concentration in the gas was thereby controlled via the temperature of the water (water vapor pressure) and the total pressure of the gas. The syngas/water mixture simulated the reactant composition produced by a typical steam-reformer operating on JP-8 with an exit temperature of 900°C. Air was controlled and fed into the opposite end of the reactor to the cathode. Electrical performance was adjusted with a V/I control circuit, where the current was maintained constant and voltage monitored with time using computer data acquisition. Current could be adjusted to achieve any desired level of fuel utilization. All test equipment was given routine maintenance and calibration checks as well as periodic random checks.

The particular test conditions and order of priority are shown in Tables 1 and 2. Initial tests were performed using TMI standard components with syngas fuel compositionally equivalent to simulated reformed JP-8 containing 0.3 wt% sulfur (approximately 300 ppm H₂S in the syngas). Alternative sulfur concentrations were obtained by mixing no-S and high-S syngas flows to achieve the desired mixture. The target operating period was at least 100 hours of stable operation. Short term and long term tests were planned to characterize the full operational range of performance. Tests were replicated to ensure reproducible results.

Figure 4. Test System Schematic.

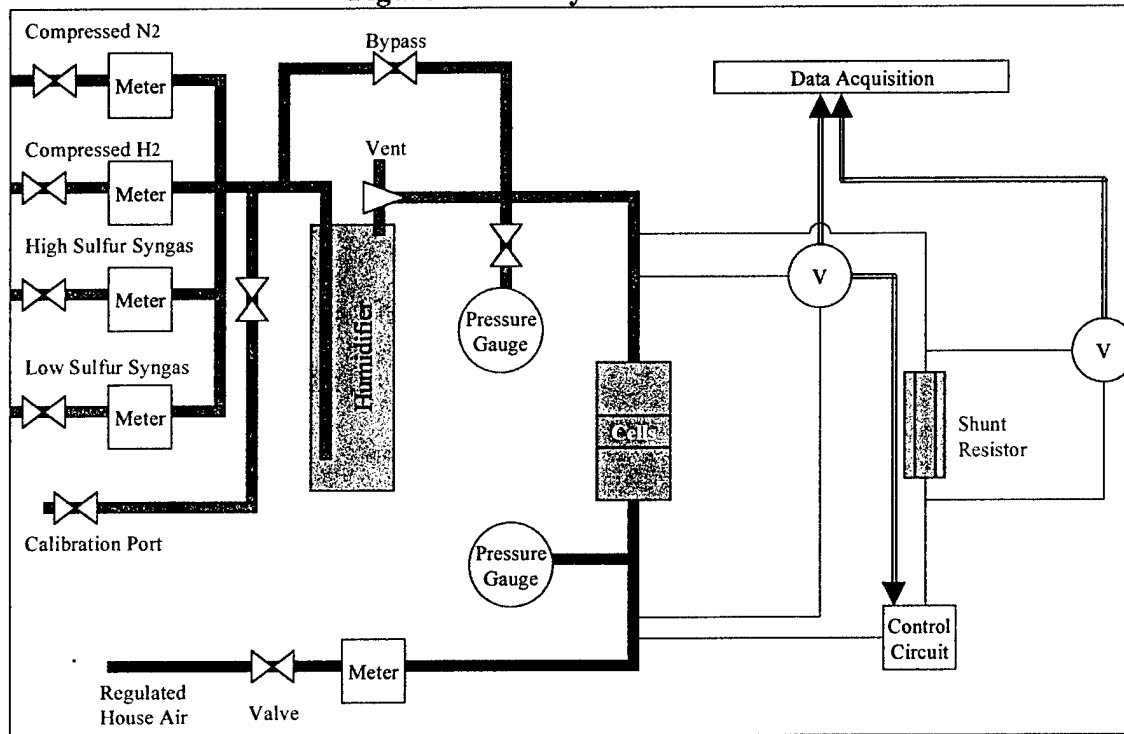

Table 1. Primary Test Conditions.

Primary Test	Result
Test three single cells at 950°C, syngas, 72 hour increments, 300 ppm, 200 ppm, 100 ppm, and zero ppm (as necessary). Repeat test at 850°C. Conduct experiments at 200 mA/cm ² , 50% FU on syngas, 3.5:1 S/C.	Reveals a practical limit for the existing materials set at one operational condition.

Table 2. Secondary Testing Conditions.

Variation	Basis	Ranges
Increase Fuel Utilization	Fuel utilization can affect oxidation behavior at the cell rim which may in turn affect degradation in performance.	up to 90%
Higher Current Density Conditions	Increased current density increases local heating and increases molar flow rate of components.	up to 300 mA/cm ²

3.0 Results of Task Work

3.1 Reactor Stability and Contamination

Stable fuel gas feed is critical in maintaining constant fuel utilization conditions. Flow variations of even 20% can impact performance by two times the normal cell-to-cell variation (~100 mV). Transient variations of humidifier temperature above 100°C can result in flash boiling of water resulting in a pressure pulse that can shatter a cell. To avoid water condensation between the humidifier and the reactor, heated/insulated transfer tubes are used. Multiple temperature and flow control systems must all work together over an extended time period in order to determine the time dependent characteristics of any cell test.

The first step of this program was to prepare five test stands (i.e., Figure 3) capable of operating under various syngas concentrations and different flow conditions. In anticipation of problems with hydrogen sulfide contamination in the fuel gas, all humidifiers were rebuilt using stainless steel and aluminum fittings to prevent corrosion. The entire existing gas manifold (from the regulators to the cells) was inspected/replaced and a high sulfur syngas manifold was added, suitable for sulfur concentrations up to approximately 300 ppm H₂S in syngas. Redundant rotometers were also installed in the fuel stream for visual flow verification. Stable experimental conditions were required to achieve conclusive results. In addition, tests had to be validated in multiple experiments (nominally, three accurate tests).

Despite numerous precautions, unanticipated variations in stand stability still occurred. Consistent flow conditions could not be maintained over time despite extraordinary steps to perform regular preventative maintenance and calibrate mass flow meters. In a typical test, flow was checked at least once every month or after every run, whichever occurred first. In syngas experiments, every fuel flow meter was replaced or recalibrated, almost weekly. Because of the

sensitivity of the tests to flow variations, manual fuel flows checks on all syngas stands were often performed *daily* with a portable bubble meter. These stability problems appeared to be unique to syngas. For example, on hydrogen fuel (even hydrogen containing sulfur), flow meters remained consistent and accurate for months with little variation.

A number of other failures also occurred. Some tests were compromised because of clogged spargers (a porous sparger is used in every humidifier to provide water contact with fuel gas). Other tests were compromised by thermal overshoot of the humidifier caused by improperly tuned controllers.

Troubleshooting Symptoms of Syngas Problems

Initially, hydrogen sulfide was assumed to be the problem source since both corrosion and passivation are known problems with this gas. However, during a routine stand inspection, three small sections of clear plastic tubing (two leading to humidifiers, one leading to a humidifier bypass tube) were found to be coated with black residue. This contamination was initially thought to be brass corrosion (i.e., CuS) caused by reaction with hydrogen sulfide. However, since all brass and/or copper components had been removed and replaced with aluminum or stainless steel, other reaction mechanisms had to be considered.

Samples taken from the tube were analyzed via optical microscopy and SEM. Shown in Figure 5, these indicate a thin, golden colored film, approximately 10 microns thick. Chemical analysis by EDX indicated the major components to be iron, nickel, and sulfur.

Figure 5. SEM and Optical Microscopy on Tube Residue.

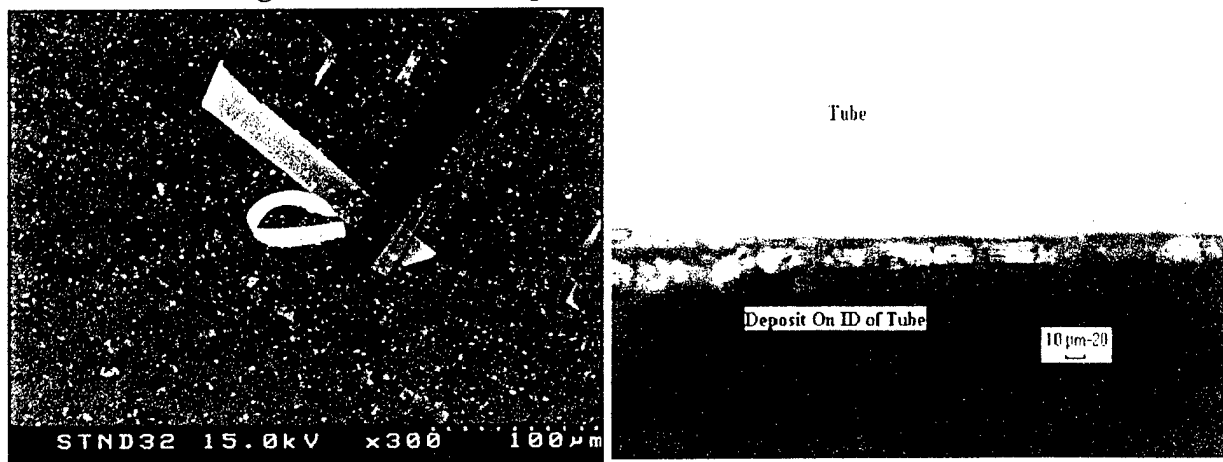

This analysis led to several conclusions.

- Iron sulfide, the obvious corrosion product of iron and H₂S, was unexpected in the syngas stands. Single cells operated routinely on H₂/H₂S mixtures have exhibited no corrosion products even after years of testing. This reaction route seems kinetically limited at standard temperature conditions.

- The presence of nickel in substantial quantities was also unexpected. Nickel is a low concentration, minority element in the grade of stainless steel used for reactors. The EDX analysis suggested more nickel than iron.
- The thin and continuous films resembled a chemical vapor deposition (CVD) coating more than a particulate coating (as might be expected in corrosion of steel).

Based on the observations and experience of Dr. Robert Ruhl, the gas stream was theorized to contain iron and nickel carbonyl (both gasses). If present, iron and nickel carbonyls would react with hydrogen sulfide to form FeS and NiS. Dr. Ruhl's theory was validated by discussion with Air Products™, TMI's supplier of syngas.

Conversations with an Air Products, Inc., staff chemist revealed that iron and nickel carbonyls are contaminants found in all commercially available carbon monoxide gas mixtures at trace levels.^[2] Neither gas is listed on the materials composition / safety sheet because of the low levels (about 1-10 ppm at the source). Nickel carbonyl forms spontaneously in the storage containers at Air Products because of the high CO pressure. Iron carbonyl formation is also thermodynamically favored and is catalyzed by any H₂O contamination in the same container. Air Products transports CO containing gasses in aluminum cylinders to end-users but government regulations require that CO be produced and stored in large quantity in steel containers. Formation of carbonyl at small levels is therefore inevitable. Further, according to Air Products, TMI has the 'ideal mixture' for creating additional trace carbonyl contamination because water is a major contaminant in gaseous carbon dioxide, the other carbon gas in the syngas mixture used for this experimental matrix.

In practice, the decomposition reaction of metal carbonyl and hydrogen sulfide is kinetically limited at room temperature but appears to readily occur upon heating. All areas where a coating was found were in elevated temperature regions (i.e., leading into the humidifier, near the bypass valve, etc).

The ramifications on the program were both numerous and systemic, not just because of the carbonyl itself, but because of how the coating fouled various components in the gas manifold system, particularly the mass flow meters. The mass flow meters in the TMI test stands use a thermal detection system to measure changes in molar gas flow. A small amount of the flowing gas is diverted through a heated stainless steel capillary tube. The meter measures the change in temperature between two points (heat transferred) to determine the mass flow. The capillary itself is only ~50 microns in diameter so as the Ni/Fe sulfide deposits build up in the tube, the meter accuracy degenerates because the gas flow is increasingly restricted. In systems with mass flow controllers, the problems are more severe because the flow control is established by the meter reading. As the sensing capillary changes dimensions with the deposited film, the flow controller compensates in an attempt to keep the flow constant.

A second heated area within the gas stream is through the porous sparger in the humidifier. The sparger has a 10 micron pore size to form high surface area bubbles in the heated water. Solids deposited in the pores clog the sparger, ultimately stopping flow or causing excessively high back pressure.

[2] A copy of a letter from Air Products is available on file.

A graphical example of this problem is illustrated in Figure 6. Two single cells running in adjacent reactors were started on $H_2/N_2 + 5\% H_2O$ and then switched to $H_2 + 39\%H_2O$ to establish baseline performance. Both were very similar. One reactor operated on a mass flow controller while the second reactor was controlled manually. After one week, the reactor with the mass flow controller had degraded considerably. The reactor with manual flow verification showed essentially no degradation. Verification of fuel flow to the reactor with the controller (using a bubble meter) indicated that the fuel flow rate had decreased by nine sccm (~15%) over one week. When the flow was restored to the reference condition, the performance returned to nearly that of the other stand. This illustrates that without effective gas flow control, rates of degradation cannot accurately be determined.

One additional experimental set-up problem was identified. During operation at high water content, the humidifiers must be refilled frequently. Refilling the humidifiers results in a loss of fuel to the cell for about 30-60 minutes. In several cases, degradation rates dramatically increased following the refilling procedure. To mitigate this effect, the final tests were run on syngas for about 170 hours - the longest run possible without refilling the humidifiers.

Figure 6. Cell Performance on Syngas + 150 ppm H_2S .

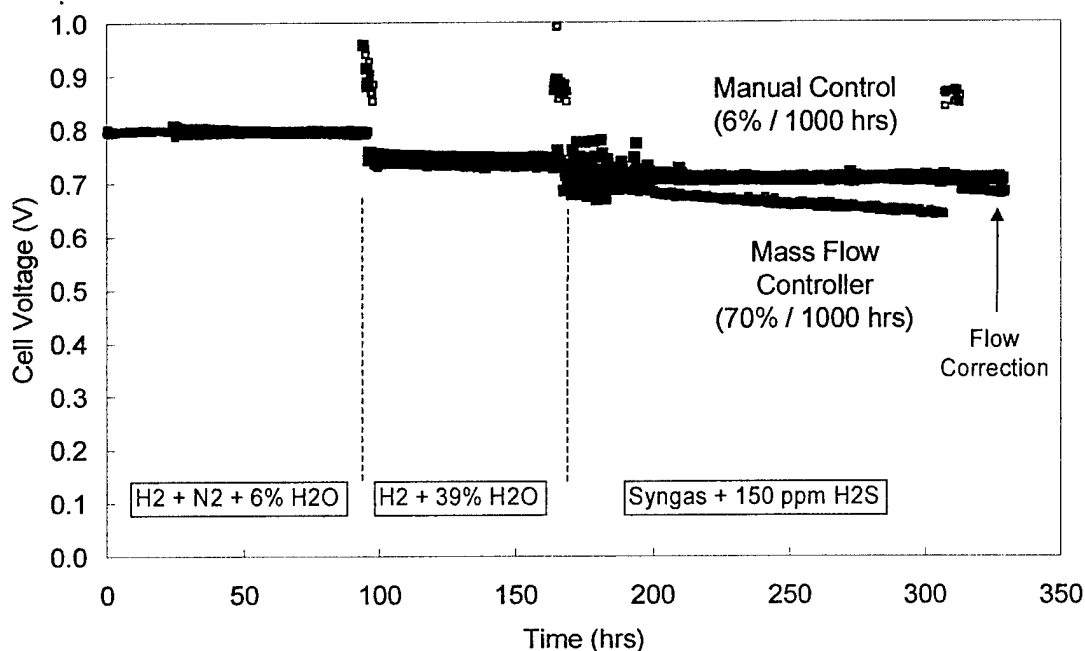

Remedial Actions

A number of remediation attempts were made including stand tear-down and rebuild, manual control systems and frequent calibrations, preliminary designs for a 'carbonyl' trap, and plans for moving to larger test configurations with inline reformers. The short duration of the program precluded most solutions. Tests were therefore restricted to those reactors that had suffered the least damage by sulfide-deposition, to test durations of no more than 170 hours at any given condition, and conditions were manually validated daily.

3.2 Task 1. Evaluation of Sulfur Tolerant Anode Materials in Single Cells

Over the six month program, about 50 cells were constructed and tested. The objective was to establish an unambiguous window of operation on sulfur bearing syngas as stated above, however, because of the aforementioned reactor instability, this was not achieved. The tests did reaffirm that a fundamental window of opportunity *does exist* and that for the typical anode there is an upper limit to stability (as expected from the thermodynamic calculations). The cell shown above in Figure 6 is one example of stable performance.

Cell tests showed low degradation more consistently on 150 ppm H₂S as compared to 300 ppm H₂S. An example is shown in Figure 7 comparing both 150 and 300 ppm H₂S in syngas. Neither cell test experienced 'catastrophic failure' but a lower degradation rate was demonstrated on the 150 ppm cell than the 300 ppm cell. Higher rates of degradation may also be associated with the presence of syngas. Cells seem to have a slightly higher degradation rate initially on syngas compared to the hydrogen reference gas as shown in Figure 8. However, because of the continual impact of sulfide-deposition, the degradation may be due to either gas composition *or* test conditions.

Optical and scanning electron microscopy and compositional analysis revealed additional insights regarding the effects of sulfur-bearing fuel on anode materials. Two sets of cells were evaluated: those that performed well with no more than moderate degradation and those that experienced high rates of degradation. A micrograph of the anode for a 'good' cell is shown in Figure 9. The secondary electron image, which is sensitive to surface topography, shows a uniform porous layer bonded to the YSZ electrolyte support in many places. The back scatter electron image, which is sensitive to atomic weight, indicates that the porous layer is a continuous but dispersed two phase mixture of the primary electrode materials. The "A" and "B" in the secondary electron image represent the two components of the cermet as indicated in the back scatter image. The dark inclusions in the electrolyte from the back scattered micrograph are alumina, not porosity. Alumina is a common 'impurity' found in high grade YSZ powder to minimize grain growth.

Figure 7. Cell performance on 39% H₂O and sulfur bearing syngas (150 and 300 ppm sulfur, 200 mA/cm² current density).

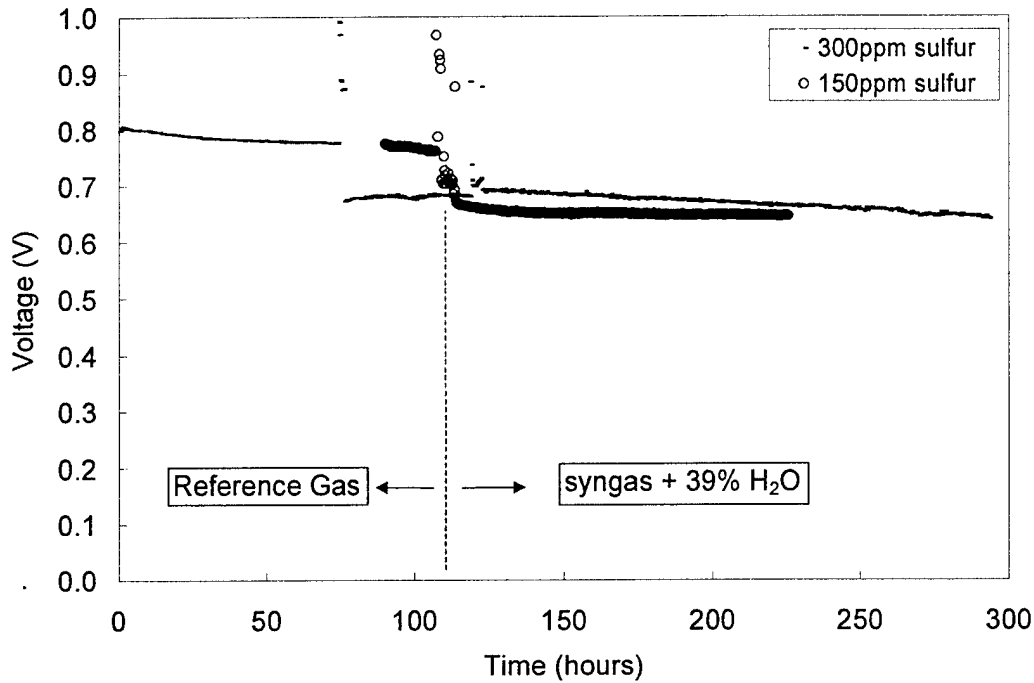

Figure 8. Reversible Experiments on 150 ppm sulfur bearing syngas (200 mA/cm²)

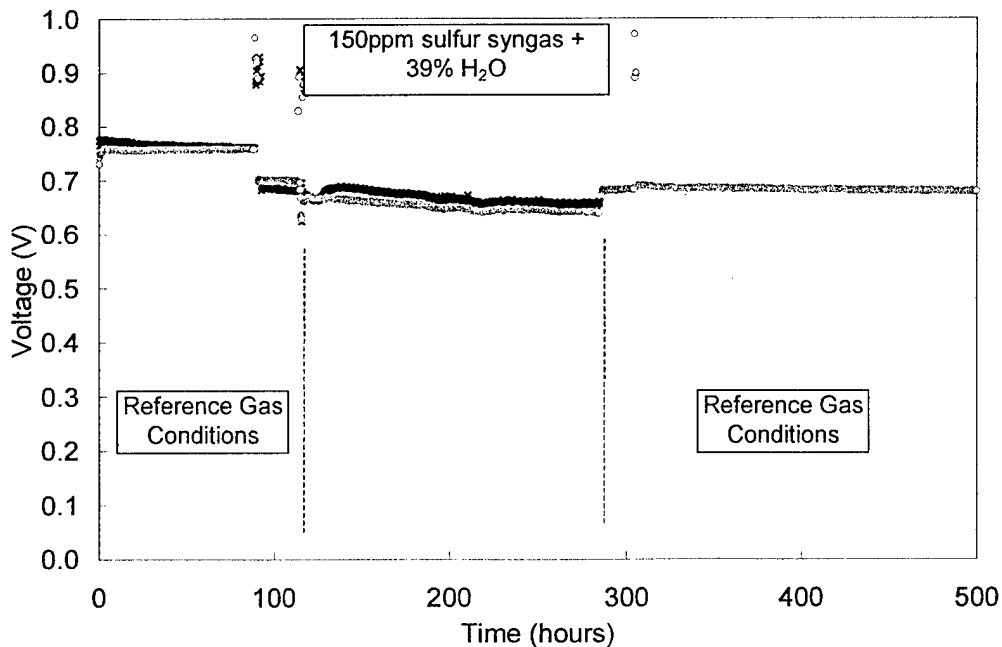
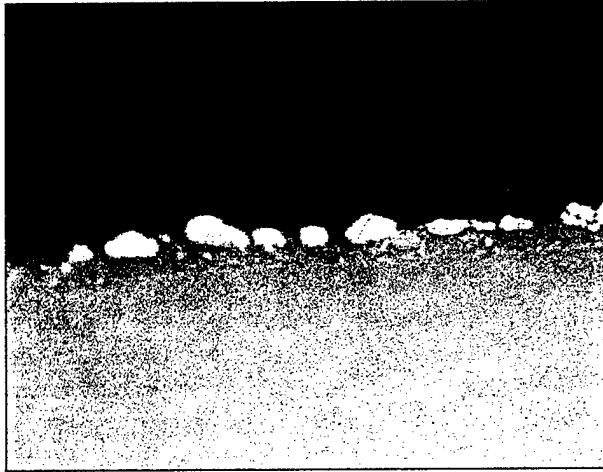

Figure 10. Agglomeration of and separation of metallic phase in the anode cermet.

Optical (side view)



Secondary Electron (top view)

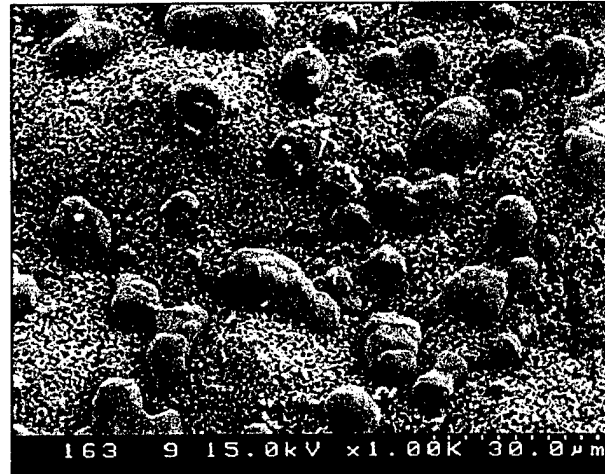

Figure 11. Manganese contamination “crystals” on anode surface.

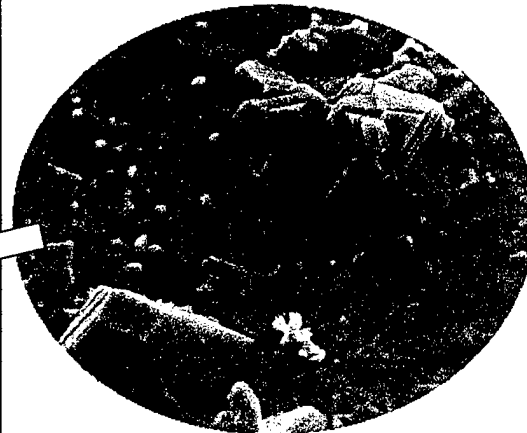
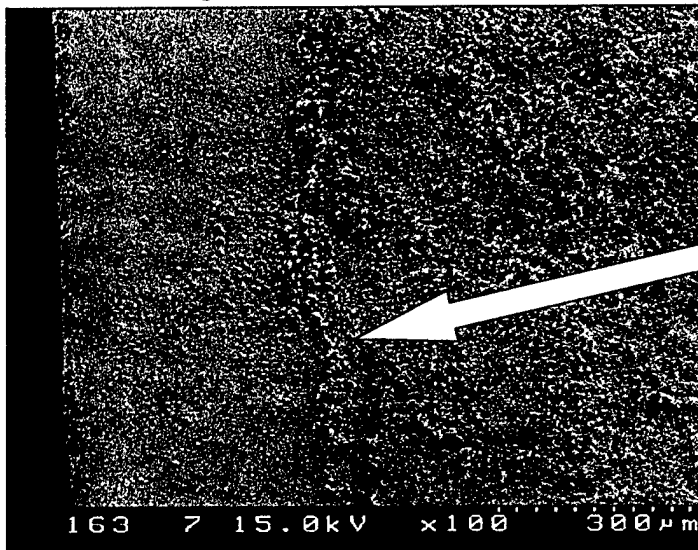
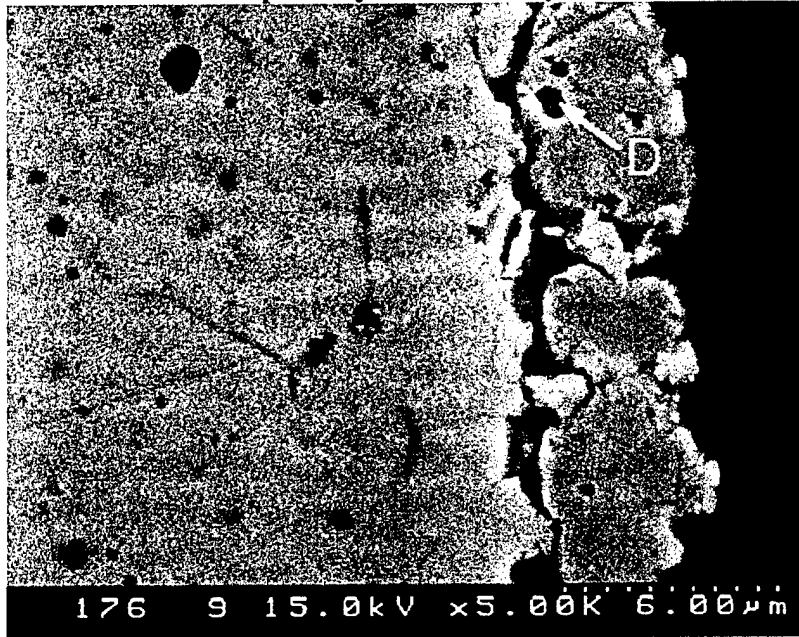

Figure 12. High magnification image of manganese contamination (point D) in primary ink anode layer.



3.2 Alternative Anode Compositions

Early in the program, the possibility was considered that cell failures were actually a sulfur instability problem. As an alternative, another anode based on an early TMI proprietary sulfur-tolerant composition was considered. Since TMI has limited experience fabricating this alternate composition using current procedures, rapid development was initiated. Because of limited time, one composition (fabricated using two different methods) of anode was tested. Preliminary screening experiments were completed indicating that this composition would not be effective within the time constraints of this program so any further refinement was discontinued.

3.3 Task 2. Evaluation of Sulfur Tolerance in Short Stacks

Tests were not completed on Task 2 because of problems under Task 1. Proposed efforts allocated for this task were re-directed at solving the Task 1 problems.

3.4 Task 3. Simulated Operation Environments for Investigating Catastrophic Failure Mechanisms.

As with Task 2, tests for Task 3 were not completed because of Task 1 problems. TMI still believes that applied voltage will be a critical factor in long term cell and stack stability.

4.0 Conclusions

Technology Management, Inc. has tested anode materials under a wide variety of conditions including operation on sulfur containing gasses, both $H_2 + 300 \text{ ppm } H_2S$ and processed 'syngas' with 0.3 wt% sulfur. Although tests indicated tolerance to sulfur exposure, experimental complications precluded achieving definitive results based on preset conditions. Trace

contaminants in the syngas mixture were found to react with the high levels of sulfur contaminants producing compounds that deposited in any region of the fuel delivery manifold where temperature was elevated. Discussions with TMI's syngas vendor indicated that iron and nickel pentacarbonyls exist in all bottled carbon monoxide as a byproduct of gas production. The mass flow meters and flow controllers use a differential thermal measurement system whose operation was corrupted by the deposition of iron and nickel sulfide reaction products, which invalidated test interpretation and data analysis.

5.0 Recommendations for Future Work

Recommendations for moving forward include:

- 1.0 Testing small stacks with integrated steam reforming systems. This bypasses experimental complications with bottled syngas. Technology Management, Inc. routinely tests 10-15 cell stacks in this manner. The negative aspects of this test are increased complexity and the added reformer interactions with the gas stream.
- 2.0 Additional work should also be completed in the area thermal integration and balance of system. Although sulfur tolerance is a key feature of a logistics fuel system, other equally important facets of the logistic fuel processing subsystem deserve additional consideration. These include start-up reformer operation, transient reformer response such as during load following, and shut-down cycling conditions.