

**A Compendium of Bonded Repairs
Applied to the PC9/A Full Scale
Fatigue Test Article During Testing**

Richard Bartholomeusz,
Rowan Geddes and Peter Chalkley

DSTO-TN-0324

DISTRIBUTION STATEMENT A
Approved for Public Release
Distribution Unlimited

A Compendium of Bonded Repairs Applied to the PC9/A Full Scale Fatigue Test Article During Testing

Richard Bartholomeusz, Rowan Geddes and Peter Chalkley

**Airframes and Engines Division
Aeronautical and Maritime Research Laboratory**

DSTO-TN-0324

ABSTRACT

A number of bonded composite repairs were applied to the PC9/A full-scale fatigue test article during its fatigue test to help achieve the target of greater than 50,000 simulated flight hours. The aim of the test was to provide RAAF with data to enable the through-life structural fatigue management of PC9/A aircraft in their fleet. Bonded repairs were applied to cracks that occurred in the wing centre-section on the lower wing skin and in the fuselage skin near the tail fin. The repairs were successful in stopping crack growth in the skin without affecting stresses in the underlying spars, which was critical in allowing proper lifing calculations. This report lists all the bonded composite repairs applied and for each repair, details its location, geometry and design and application notes. While the repairs were applied primarily to assist the smooth running of the fatigue test some of the repairs provide a starting point for design of future repairs to RAAF aircraft should cracking occur or if they are to be applied as a preventative measure at the same locations.

RELEASE LIMITATION

Approved for public release

20010302 188

DEPARTMENT OF DEFENCE
DEFENCE SCIENCE & TECHNOLOGY ORGANISATION

DSTO

AQ FOI-0974

Published by

*DSTO Aeronautical and Maritime Research Laboratory
PO Box 4331
Melbourne Victoria 3001 Australia*

*Telephone: (03) 9626 7000
Fax: (03) 9626 7999
© Commonwealth of Australia 2000
AR-011-653
November 2000*

APPROVED FOR PUBLIC RELEASE

A Compendium of Bonded Repairs Applied to the PC9/A Full Scale Fatigue Test Article During Testing

Executive Summary

AMRL has conducted a full-scale fatigue test of a PC9/A aircraft with the aim of establishing a validated safe-life of airframe and providing RAAF with data to enable the through-life structural fatigue management of PC9/A aircraft in their fleet. Adhesively bonded boron/epoxy repairs were applied to cracks that formed in the test article and were very successful in enabling continued testing. Repairs were mainly applied during scheduled down time of the rig and this allowed continued testing with minimum disruption. Bonded repairs proved to be an excellent option because their relatively small and unobtrusive nature meant that the critically important spar stresses were largely unaffected by their presence while crack growth in the wing skin was stopped. Consequently the lifing calculations for the critically important spars remained valid. This report lists all the bonded composite repairs applied and for each repair, details its location, geometry, design and application notes. While the repairs were applied primarily to assist the smooth running of the fatigue test some of the repairs provide a starting point for design of future repairs to RAAF PC9/A aircraft should cracking occur at the same locations. It is also possible that such repairs may be applied to the fleet as reinforcements to reduce stresses and prevent cracking.

Authors

Richard A. Bartholomeusz

Airframes and Engines Division

Richard Bartholomeusz graduated from the Royal Melbourne Institute of Technology with a Bachelor of Aeronautical Engineering. On completion of his degree he joined the Royal Australian Navy as an Aircraft Engineering Officer working on an operational helicopter squadron. He has completed an Associate Diploma in Management and a Graduate Diploma in Aircraft Engineering Management. After joining AMRL, Richard has been involved in the design, development and testing of advanced composites and adhesively bonded joints. In particular, he has worked on the development of battle damage repair techniques and the manufacture and design of composite structures. His areas of interest are the use of composite materials and bonded joints in aircraft structural repair.

Rowan Geddes

Airframes and Engines Division

Rowan Geddes joined AMRL as PO1 in August 1998, and has completed a degree in Aerospace Engineering (Hons) and an Associate Diploma of Aerospace Systems Engineering at RMIT. He is an active committee member of the Melbourne Branch of the Royal Aeronautical Society. Rowan is currently working with the Composites Group at AMRL.

Peter D. Chalkley

Airframes and Engines Division

Peter Chalkley is a Professional Officer at AMRL and has a B.Sc. (Hons) in Metallurgy from the UNSW and a M.Sc. in Mathematics from the University of Melbourne and is currently a member of the Australian Composites Society. He joined AMRL in 1986 and has worked on the materials science of adhesives and composite materials.

Contents

1. INTRODUCTION.....	1
2. PC9/A BONDED REPAIR LOCATIONS	1
3. DESIGN AND APPLICATION OF THE REPAIRS	5
3.1 Slotted hole in the top skin at the forward fin attachment.....	5
3.2 The uplock mechanism repairs	6
3.2.1 Click Bond 200 Structural Acrylic Repairs	6
3.2.2 FM73 Structural Epoxy Repair	8
3.3 Lower Wing-Skin Drain Hole Repairs	9
3.4 Wing Skin Lower-Surface Access Hole Repairs	10
3.4.1 Drawings of the access hole repairs - port side.....	11
3.4.2 Drawings of the access hole repairs - starboard side	12
3.5 Port fuel vent-hole repair	14
4. CONCLUSIONS.....	15
5. REFERENCES	16
APPENDIX A:GENERIC DESIGN NOTES FOR THE DRAIN HOLE REPAIRS	17
A.1. MATERIALS SELECTION	17
A.2. REPAIR DESIGN.....	18
A.3. REPAIR APPLICATION	24

1. Introduction

AMRL undertook a full-scale fatigue test of a Pilatus PC9/A aircraft with the aim of providing RAAF with data to enable the through-life structural fatigue management of RAAF's fleet of PC9/A aircraft. Significant cracking [1,2] occurred during testing in the wing centre-section lower wing-skin access and drain holes, in the landing gear door uplock mechanism and in the fuselage skin near the tail fin attachment.

To enable the fatigue test to attain its goal of achieving greater than 50,000 simulated flight hours (SFH), AMRL-designed bonded boron/epoxy repairs were applied to these and other crack locations. Rapid application of these repairs ensured a quick restart of the fatigue test. Furthermore, bonded repairs proved to be an excellent option because their relatively small and unobtrusive nature meant that the critically important spar stresses were largely unaffected by their presence while crack growth in the wing-skin was slowed or stopped. Also, because of their anisotropic material properties, the patches locally stiffen the structure only in the direction perpendicular to the crack path (along the fibre direction). The alternative of a mechanically fastened, isotropic and thicker metallic patch would most likely have changed load transfer around the spar cap making life assessment for this critical structure very difficult.

This report details all aspects of the bonded repairs; Section 2 lists all the repair locations, Section 3 shows geometry and gives references to the design and application notes for each repair and conclusions are given in Section 4.

2. PC9/A Bonded Repair Locations

Figure 1 shows the PC9/A fatigue test article in its test rig.

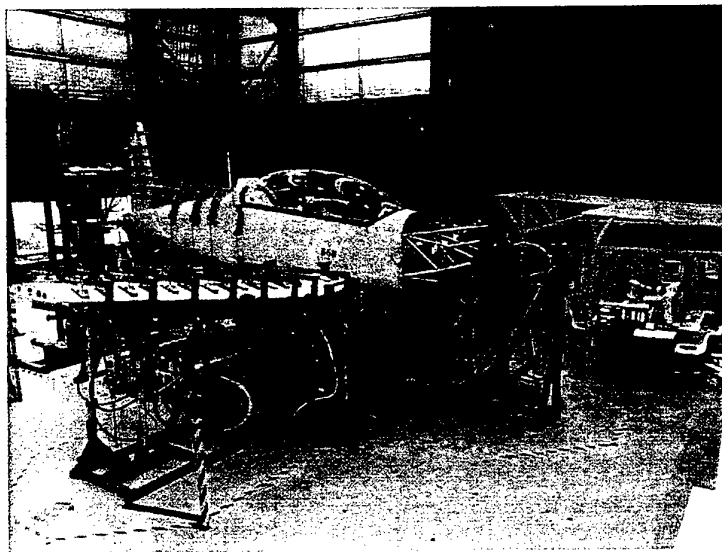

Figure 1. The PC-9/A fatigue test article.

Cracking during testing occurred in the wing centre-section on the lower wing-skin and in the fuselage skin near the tail fin. Figure 2 shows a photograph of the lower wing-skin with all the repairs applied.



Figure 2. Photograph of the centre section of the lower wing-skin showing repairs.

A schematic of the region (from reference 2) is shown in Figure 3. The nomenclature for access holes is 1S, 2S etc for the starboard holes and 1P, 2P etc for the port access holes. For the drain holes, the nomenclature is S1, S2 etc for the starboard side and P1, P2 etc for the port side. The repairs shown over the drain holes were those present at 50,000 SFH.

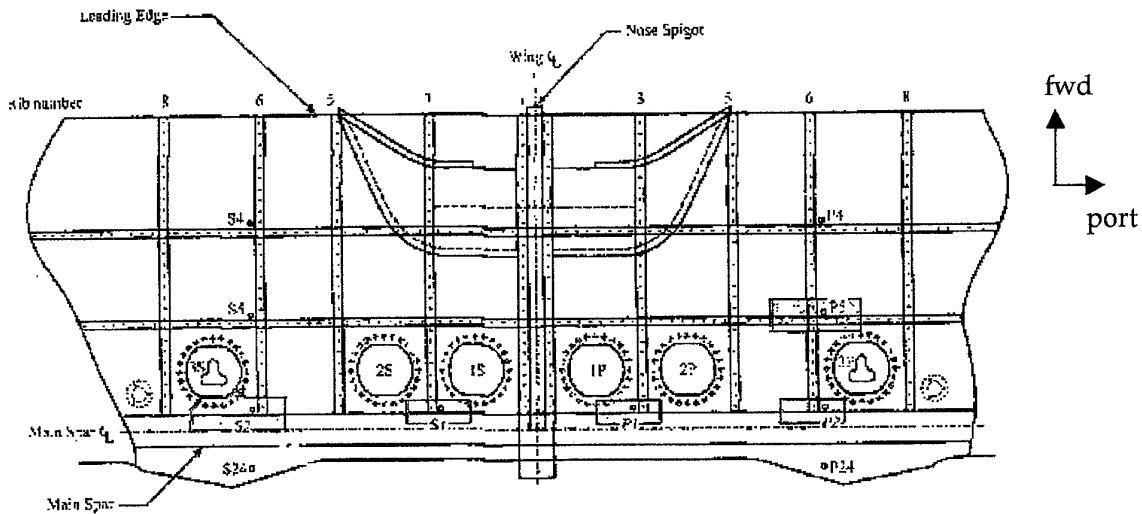

Figure 3. Schematic of the centre section of the lower wing-skin showing repairs coloured in yellow.

Table 1 lists the bonded boron/epoxy repairs to the PC9/A fatigue test article and the SFH at which they were applied [2].

Table 1. PC9/A Bonded Boron/Epoxy Repairs.

Repair location	SFH at which applied	Comments
Slotted hole in top skin at FWD fin attachment	6,000	Two part structural acrylic adhesive. Repair removed when skin panel to which it was bonded was removed at 33,000 SFH.
Lower wing-skin starboard landing gear door uplock mechanism	10,000	Two part structural acrylic adhesive. Repairs on inside and outside surface of wing-skin. No crack growth. Repairs removed at 34,000 SFH to allow modification of uplock mechanism (including re-profiling of wing-skin to lower K_i). Repairs not reapplied.
Lower wing-skin port landing gear door uplock mechanism	15,500	Two part structural acrylic adhesive. Crack grown to beyond edge of repair at 17,000 SFH. Repairs removed at 17,250 SFH. Mod. made as for STBD side.
Lower wing-skin port landing gear door uplock mechanism	38,000	FM73 adhesive. Single repair on outside of skin applied to cracked blended profile. No crack growth.
Lower wing-skin drain holes: P1, P2, and S1	23,875	Large cracks to holes repaired. No crack growth.
Lower wing-skin drain hole: P5	38,000	Large crack to hole repaired. No crack growth.
Lower wing-skin drain hole: S2	44,440	Hole size that was eventually repaired was 15mm. No crack growth.
Wing nose skin lower-surface access holes: 1P, 2P, 3P, 1S, 2S and 3S.	$\geq 37,000$	Repairs to the access holes were progressively applied from 37,000 SFH. Very successful in stopping cracking.
Port fuel vent hole (outboard of P3)	52,000	

3. Design and Application of the Repairs

The patches applied to the drain and access holes and the final patch to the port uplock mechanism were all ten plies thick and the thickness of the wing-skin was identical in each case. Consequently the design notes for each repair are virtually identical. Appendix A has the generic design notes for the drain hole repairs but these notes are applicable to all the ten ply repairs.

3.1 Slotted hole in the top skin at the forward fin attachment

An adhesively bonded boron/epoxy patch was applied to a crack in the top skin emanating from a slotted hole at the forward fin attachment at 6,000 SFH.

The patch was designed simply on the basis of stiffness matching with the aluminium skin. A three-ply unidirectional boron/epoxy layup was chosen. The thickness of the patch was approximately one third that of the skin as unidirectional boron/epoxy has a modulus approximately three times that of aluminium. The ends of the patches were stepped, at 4 mm per step, to reduce stresses at the patch ends. The patch configuration is shown in Figure 4.

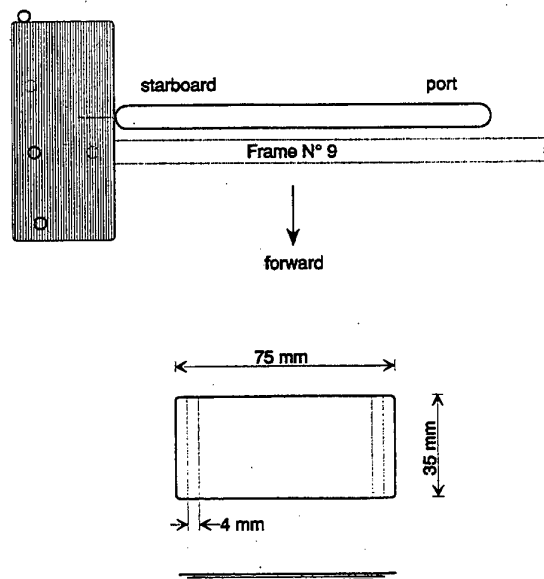

Figure 4. Repair to the slotted hole in the top skin at the forward fin attachment

No structural integrity or stress intensity calculations for the repaired crack were done for this repair.

The surfaces of the repair were treated prior to bonding as per Table 2.

Table 2. Surface Treatment for the slotted hole repair.

	Surface Treatment
Aluminium skin	Paint removed to expose bare metal. This surface was then cleaned by a methyl ethyl ketone (MEK) solvent wipe, cleaned again by abrading with Scotch Brite dipped in MEK and then grit blasted with aluminium oxide particles.
Boron/epoxy patch	The bonding surface was cleaned with MEK solvent and then lightly grit blasted.

The boron/epoxy patch was bonded to the aluminium skin using the two-part structural acrylic - Click Bond 200-40. This adhesive cures at room temperature and attains 90% of full strength within one hour. No details of the pressurisation method were recorded.

3.2 The uplock mechanism repairs

Essentially, two sets of repairs were applied to the port and starboard uplock mechanisms:

1. two patches, applied to the inside and outside surface of the skin, to both the starboard and port wings. The repair adhesive was the structural acrylic adhesive Click Bond 200-40.
2. one patch applied to the outside of the skin on the port uplock mechanism after it had been re-profiled. The patch was applied using the structural epoxy adhesive, FM73.

3.2.1 Click Bond 200 Structural Acrylic Repairs

A total of four patches - two on the starboard and two on the port uplock mechanism - were applied using the structural acrylic Click Bond 200. Three ply patches were used.

Figure 5 shows the crack location on the starboard wing as at approx. 10,000 SFH.

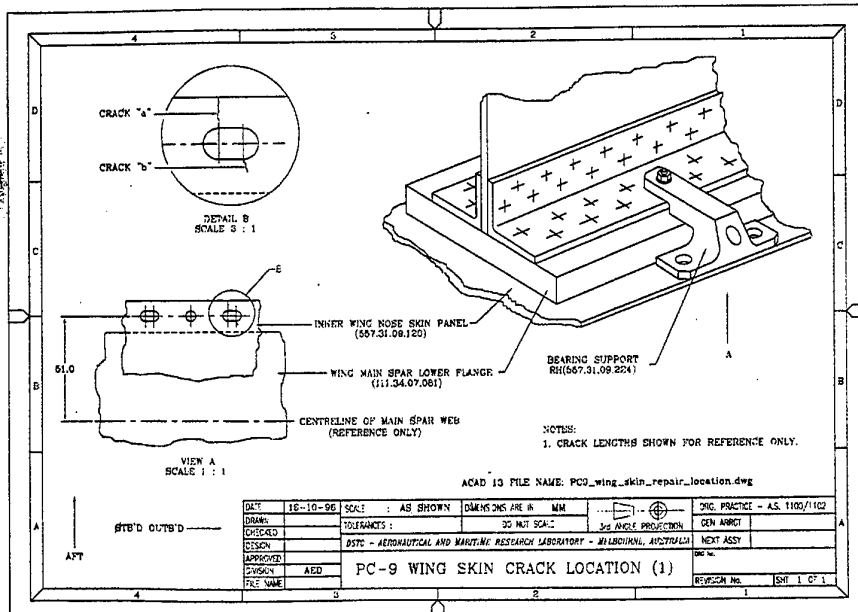

Figure 5. Starboard Wing Uplock Mechanism- Crack Location.

Figure 6 shows a drawing of the patches which were bonded to the aircraft using Click Bond 200.

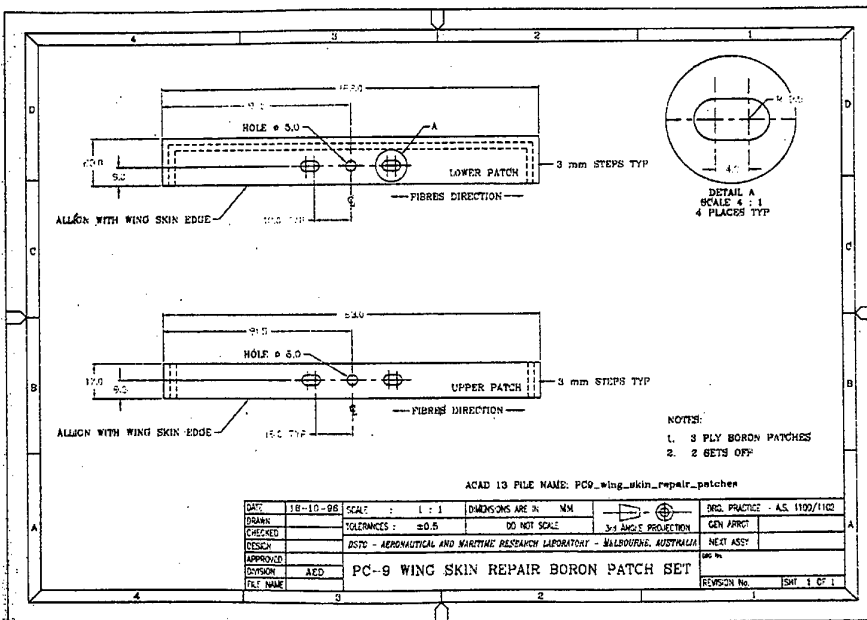

Figure 6. Starboard Wing Uplock Mechanism- Patches.

No crack growth occurred in the starboard lower skin after repair. The patches, which were applied at 10,000 SFH, were removed at 34,000 SFH to allow a re-profiling modification to the region. The port side patches were fitted at about 15,500 SFH. By 17,000 SFH the crack had grown beyond one edge of the external patch. It is thought that the use of the structural acrylic paste resulted in a very thick adhesive bondline which meant that the effectiveness of the patches in reducing crack opening would have been reduced. The patch applied subsequently to the port side used the structural epoxy adhesive FM73. A thicker patch was also employed (a single ten ply patch rather than two three ply patches).

The design and application of these repairs was carried out in accordance with the RAAF Engineering Standard on Composite Materials and Adhesively Bonded Repairs [3]. The structural acrylic adhesive Click Bond 200 was used because it cures at room temperature and it was a requirement of the fatigue test that nearby strain gauges not be damaged by heat. The patch thickness was restricted as the load in the spar could not be affected by the presence of the repairs because this would invalidate the spar lifing calculations. Should such a repair be implemented for the fleet it is recommended that the structural epoxy adhesive FM73 be used. Full design details of the repair are given in Reference 4.

3.2.2 FM73 Structural Epoxy Repair

A thicker ten-ply patch was bonded using FM73 to the blended-skin of the port uplock mechanism at 38,000 SFH following re-cracking of this part. At 38,000 SFH the underlying spar had satisfied the requirement of undergoing three lifetimes of loading and so the restriction on patch thickness due to lifing considerations was removed. Eddy-current inspection of the crack showed that this patch stopped crack growth. Figure 7 shows a drawing of the patch.

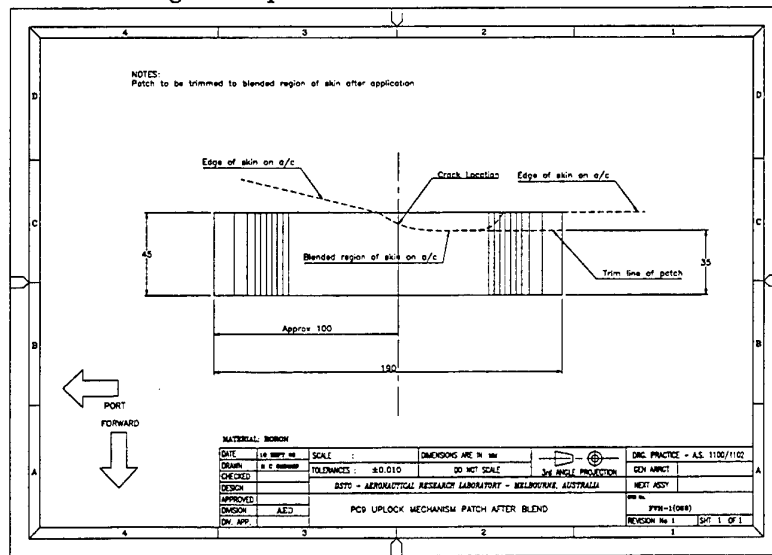

Figure 7. Drawing of the port uplock mechanism patch applied at 38,000 SFH.

The design and application of these repairs was carried out in accordance with the RAAF Engineering Standard on Composite Materials and Adhesively Bonded Repairs [3]. The design of this patch is as described in Reference 5.

3.3 Lower Wing-Skin Drain Hole Repairs

Five cracked lower wing-skin drain holes (P1,P2, S1, P5 and S2) were patched as shown in Figure 3. The drain holes were progressively patched between 23,875 SFH and 44,000 SFH (see Table 1) at scheduled downtimes for the test rig so as to minimise disruptions to the test. The locations of the drain hole patches were shown in Figure 3. The boron/epoxy patches stopped crack growth. A drawing of the generic patch applied to the drain holes is shown in Figure 8.

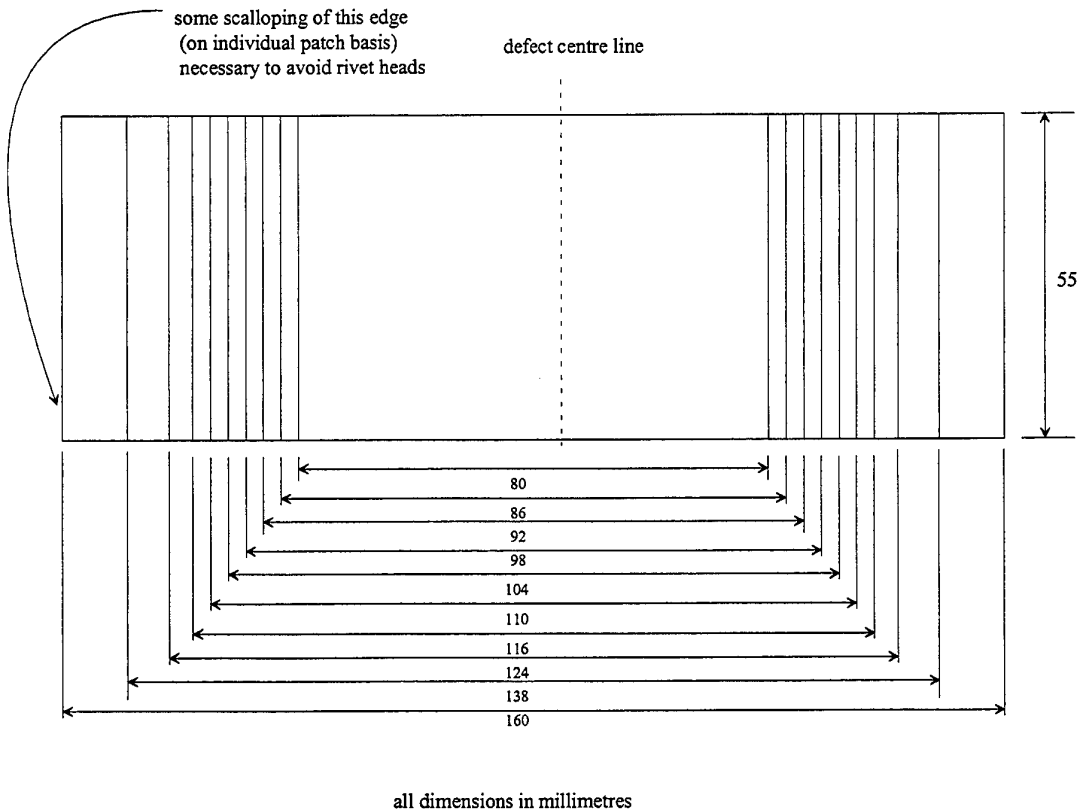

Figure 8. Drawing of the generic patch applied to the drain holes.

Details on the design and application of the drain hole patches are given in Reference 6.

3.4 Wing Skin Lower-Surface Access Hole Repairs

Seven patches to six cracked lower wing-skin access holes were applied progressively from about 37,000 SFH. The locations of the drain hole patches are shown in Figure 9. Inspection by eddy currents showed that the boron/epoxy patches were very successful in stopping crack growth.

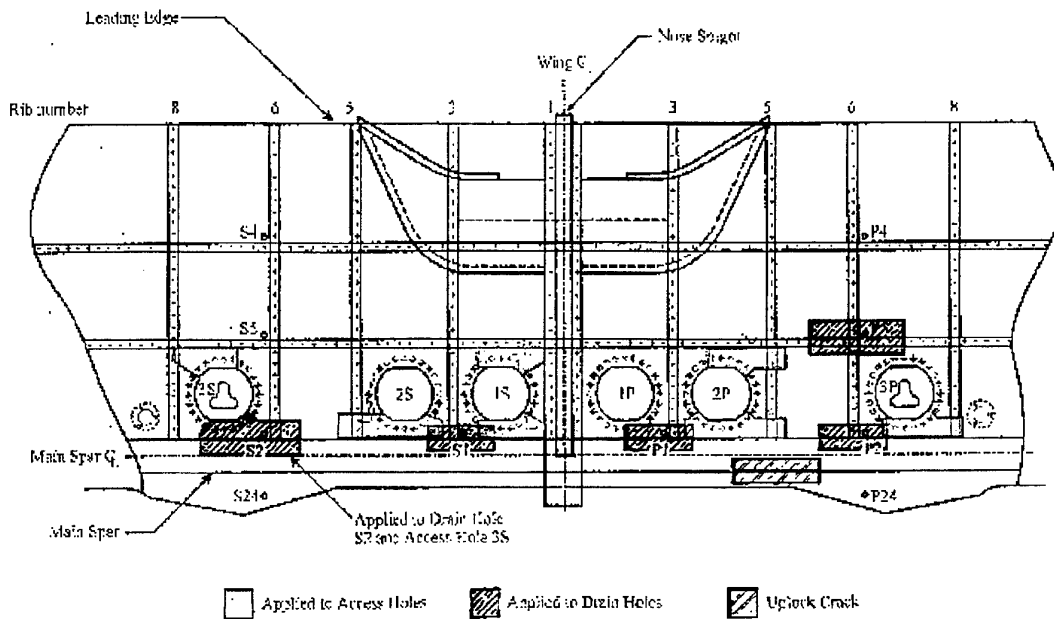

Figure 9. Drawing showing the locations and the nomenclature for the access hole repairs [2].

The following figures show drawings for each of the repair patches.

Drawings of the access hole repairs - port side

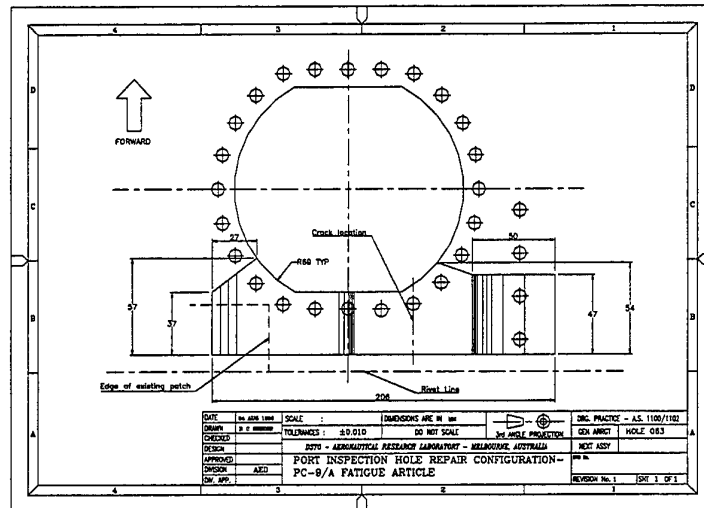

Figure 10. Access hole 2P - AFT patch.

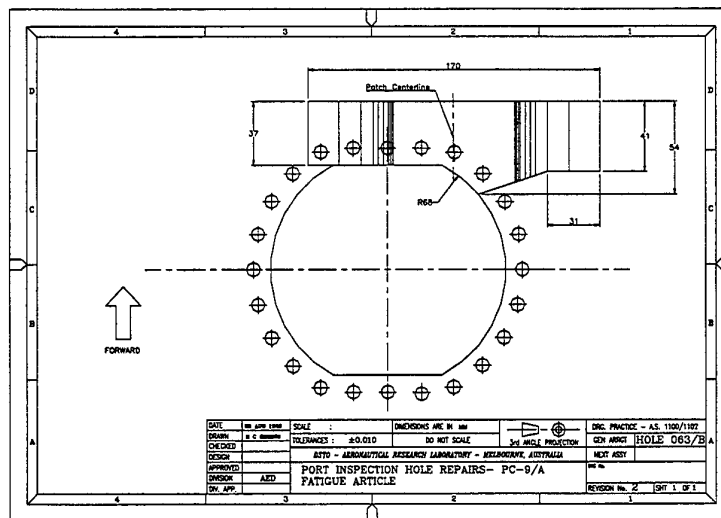

Figure 11. Access hole 2P - FWD patch.

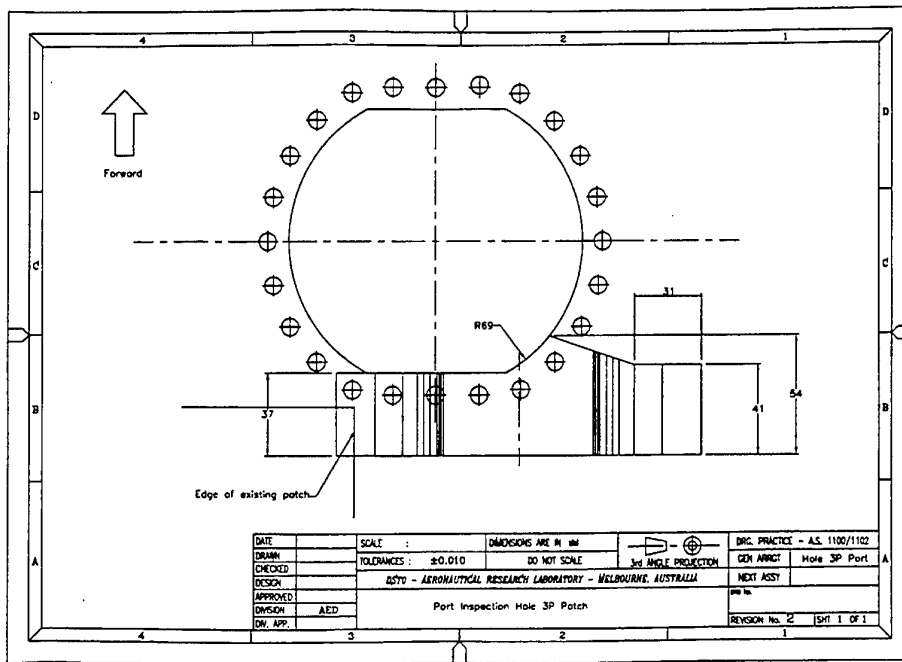

Figure 12. Access hole 3P - AFT patch.

3.4.1 Drawings of the access hole repairs - starboard side

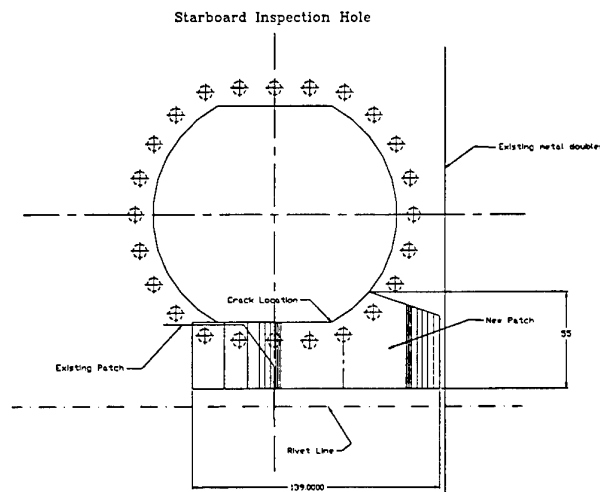

Figure 13. Access hole 1S - AFT patch.

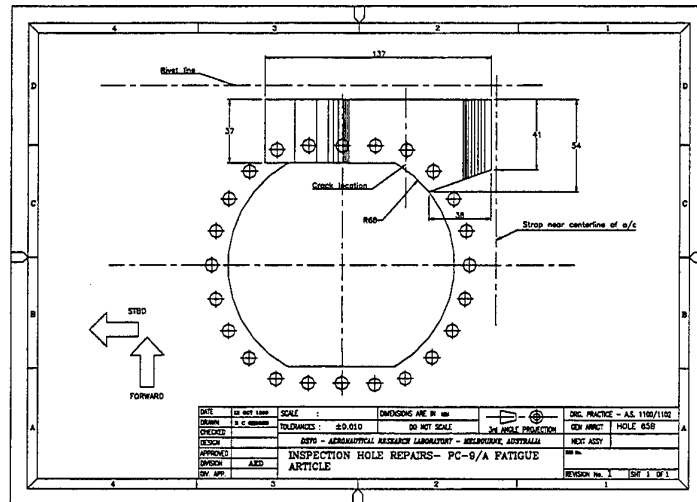

Figure 14. Access hole 1S - FWD patch.

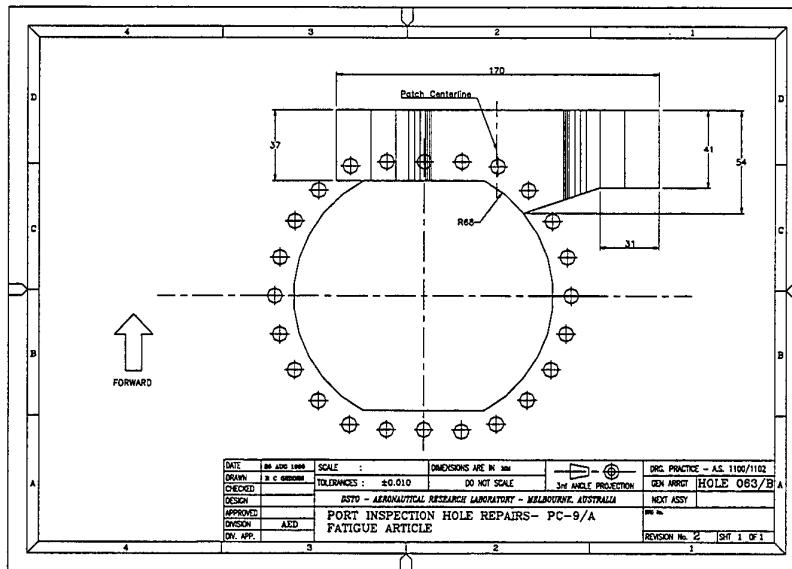

Figure 15. Access hole 2S - AFT patch.

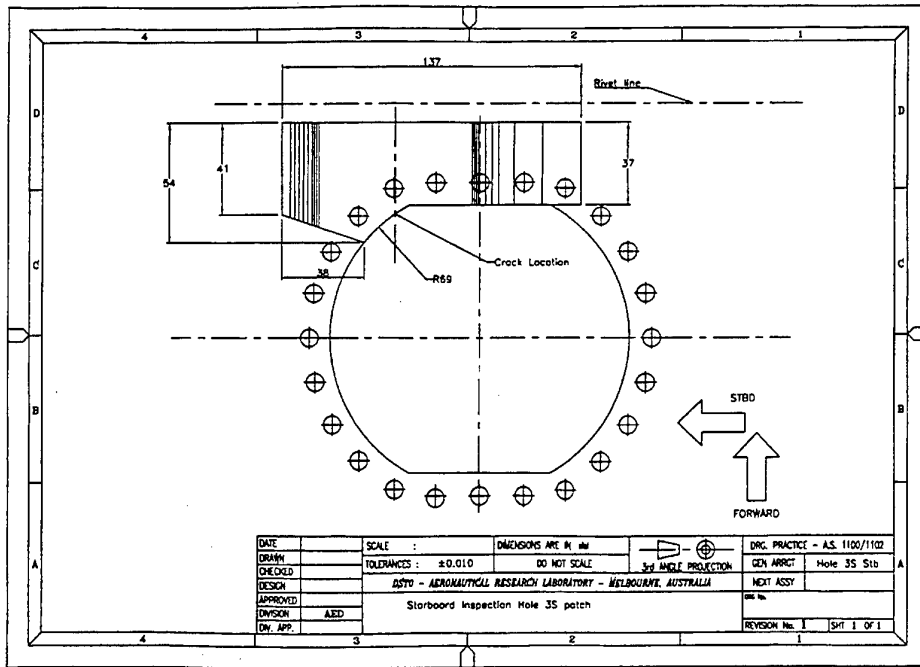

Figure 16. Access hole 2S - AFT patch.

3.5 Port fuel vent-hole repair

A patch was applied to the port fuel vent hole located just outboard of access hole P3 (see Figure 9) at 52,000 SFH. Figure 17 shows a drawing of the patch. The patch was ten plies thick and design was as for that given in Reference 5.

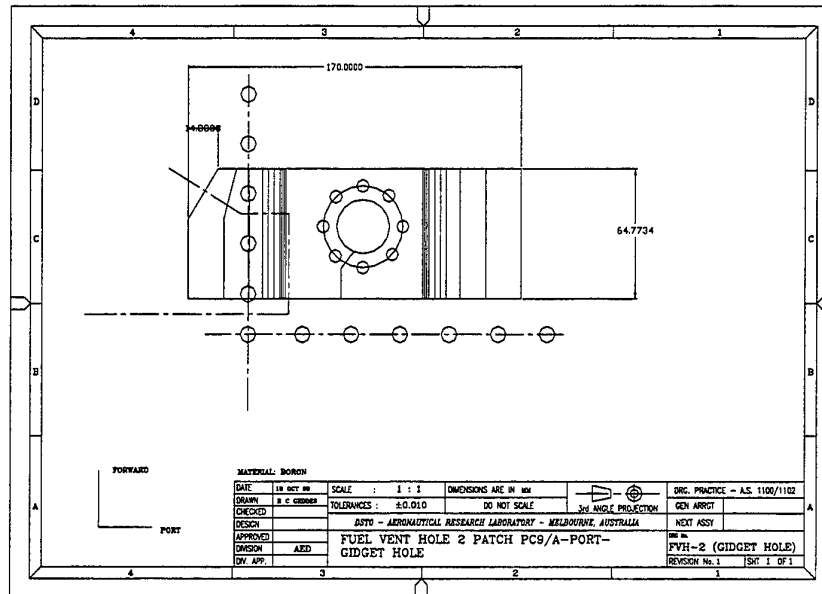

Figure 17. Drawing of patch applied to the port fuel vent hole.

4. Conclusions

The application of bonded boron/epoxy repairs to the PC9/A fatigue test article was very successful in enabling the test to continue once significant cracking had occurred at several locations. Bonded repairs were probably the only option that could stop crack growth in the wing-skin yet not significantly change the stresses in the tension spar boom.

With just one exception, the patches applied to the PC9/A fatigue test article stopped the growth of cracks to which they were applied. The one exception was the original set of patches applied to the port uplock mechanism where the crack grew past one edge of the external patch within 1,500 SFH. These patches were tailored to meet the fatigue test constraints of not damaging nearby strain gauges and of not changing the spar cap stresses. Consequently thin patches were bonded to the uplock mechanism with a room temperature curing adhesive. The repair applied to the uplock mechanism at 38,000 SFH was applied without these constraints and consequently used a thicker patch bonded using FM73 at 80°C which was successful in stopping crack growth.

Should cracking occur at the same locations in service then these repair designs provide a useful starting point for fleet wide repairs if this option is chosen. Designs

for fleet aircraft would need to consider environmental issues such as moisture, temperature and aircraft fluids which did not form part of the design for the test article repairs. For locations where cracking occurs early in the life of the aircraft then the pre-emptive approach of applying bonded reinforcements prior to cracking may be worthy of consideration.

5. References

1. P. Bates, "PC9/A Full-Scale Fatigue Test Notice of Structural Damage", NSD Nos. 063/134, 064/134, 065/134, 069/138, 070/138 and 071/138, AMRL, dated 20/7/1998.
2. I. Anderson, "PC9/A Fatigue Test, Summary of Significant Damage at 50,000 Simulated Flight Hours", DSTO-TN-0213.
3. RAAF Engineering Standard, Composite Materials and Adhesive Bonded Repairs, C5033, Issue Number 1.
4. R. A. Bartholomeusz, "Proposed Design and Application of a Bonded Boron/Epoxy Repair for Cracking in the PC9/A Lower Wing-skin", Composites Letter Report, Folio 17 of DSTO file BM2/162.
5. R. Bartholomeusz and R. Geddes, "Design and Application of Bonded Composite Repairs for Cracks from the Inspection Holes in the Lower Wing-skin of the PC9/A Full Scale Fatigue Test Article", Composites Letter Report, August 1998, Folio 2 of DSTO file BM2/162.
6. R. A. Bartholomeusz, "Design and Application of Replacement Bonded Composite Repairs for Cracks from the Drain Holes in the Lower Wing-skin of the PC9/A Full-Scale Fatigue Test Article", Composites Letter Report, Folio 16 of DSTO file BM2/162.
7. T. Tran-Cong and M. Heller, Reduction in Adhesive Shear Strains at the Ends of Bonded Reinforcements, DSTO Research Report, DSTO-RR-0115, September 1997.
8. L. Schwarmann, Material Data of High Strength Aluminium Alloys for Durability Evaluation of Structures, Aluminium-Verlag, Dusseldorf, ISBN 3-878017-183-9, 1986.

Appendix A: Generic design notes for the drain hole repairs

A.1. Materials selection

The repair materials selected for this application were uni-directional boron fibre patches bonded with Cyttec FM73 epoxy adhesive.

The material properties assumed at room temperature are as follows [3]:

Boron/Epoxy Composite	Term	Value
Young's Modulus	E_0	207×10^3 MPa
Failure Strain	ϵ_0	0.0064
Ply Thickness	t_{ply}	0.127 mm
Thermal Expansion Coefficient	α_0	4.1×10^{-6} in/in °C
Date of Manufacture		
Lot Number		

Cyttec FM73	Term	Value
Shear Modulus	G	355 MPa
Thickness	η	0.2 mm
Shear Yield Strength	τ_p	35.5 MPa
Elastic Strain Limit	γ_e	0.1
Failure Strain	γ_f	0.6
Plastic Strain Limit	γ_p	0.5
Poisson's Ratio	ν	0.33
Date of Manufacture		
Lot Number		137 (roll # 4903-01185-0008)

Al. Alloy 2024 T3	Term	Value
Young's Modulus	E_i	72.4×10^3 MPa
Thickness	t_i	2 mm
Thermal Expansion Coefficient	α_i	22.9×10^{-6} in/in °F
Ultimate Strength	σ_{ui}	441 MPa
Yield Strength	σ_{yi}	324 MPa
Poisson's Ratio	ν	0.33
Fracture Toughness	K_{IC}	91.7 MPa.m ^{1/2}

A.2. Repair design

The repair design follows procedures given in Reference 3.

Assumptions

1. The metal skin has cracked the full width of the patch and the patch is left spanning the crack.
2. The spar, and ribs in the wing will provide sufficient support to prevent out-of plane bending.
3. The repair is considered to be a single-sided supported bonded repair.

Calculate the patch thickness

The repairs were stiffness matched to the wing-skin and were made up of six plies of unidirectional boron-fibre composite. To increase the stiffness of the repair it is proposed to increase the patch thickness to ten plies. The patch thickness is thus:

$$t_o = 0.132 \times 10 = 1.32 \text{ mm}.$$

Evaluate the reparability based on the potential load capacity of the adhesive

The strength of the adhesive in the joint is given by the smaller of

$$P_{joint} = \phi + \left[2\eta\tau_p (0.5\gamma_e + \gamma_p) 2E_i t_i \left(1 + \frac{E_i t_i}{E_o t_o} \right) \right]$$

where

$$\phi = \left[(\alpha_o - \alpha_{ieff})(23.9 - T_{cure}) + (\alpha_o - \alpha_i)(T_{oper} - 23.9) \right] E_i t_i$$

or

$$P_{joint} = \theta + \left[2\eta\tau_p (0.5\gamma_e + \gamma_p) 2E_o t_o \left(1 + \frac{E_o t_o}{E_i t_i} \right) \right]$$

where

$$\theta = \left[(\alpha_{ieff} - \alpha_o)(23.9 - T_{cure}) + (\alpha_i - \alpha_o)(T_{oper} - 23.9) \right] E_o t_o.$$

The cure temperature (T_{cure}) for FM73 is 80°C and the operating temperature (T_{oper}) is assumed to be room temperature or 23.9°C for the fatigue test article. The surrounding structure is assumed to provide some restraint during cure and thus the effective thermal expansion coefficient of the wing-skin is given by

$$\alpha_{ieff} = \frac{\alpha_i(1 + \nu)}{2}.$$

The load intensity in the adhesive is thus given by

$$P_{joint} = 1411 \times 10^3 \text{ N / m}.$$

For the Rapid Repairability Criterion [3], if it is conservatively assumed that the maximum stress that could be experienced by the aluminium wing-skin is the material ultimate stress in the wing-skin near the damaged location, then load intensity is given by

$$P_{metal} = 1.2\sigma_u t_i = 1062 \times 10^3 \text{ N / m}.$$

Therefore

$$P_{joint} > P_{metal}.$$

Based on the above, the repair should be capable of withstanding the maximum loads expected in the wing-skin even if cracked to the width of the patch.

Evaluation of structural integrity of repaired structure

The stress in the metal skin at the end of the patch is given by

$$\sigma_{ep} = \Omega_L \sigma + E_i \left[(\alpha_o - \alpha_{ieff}) (23.9 - T_{cure}) + (\alpha_o - \alpha_i) (T_{oper} - 23.9) \right],$$

where $\sigma = 1.5\sigma_{II}$ and the load inclusion factor is given by

$$\Omega_L = 1.2 \text{ [3].}$$

Thus

$$\sigma_{ep} = 333 \text{ MPa.}$$

Therefore

$$\sigma_{ep} < \sigma_{ui}$$

and the metal skin at the end of the patch should be capable of withstanding the maximum loads expected.

The stress in the wing-skin under the repair is given by

$$\sigma_o = \frac{E_i t_i \sigma_{ep}}{(E_o t_o + E_i t_i)}.$$

The maximum adhesive shear strain is given by

$$\gamma_{\max} = \frac{\sigma_o t_i \lambda}{G}, \text{ where}$$

$$\lambda^2 = \frac{G}{\eta} \left(\frac{1}{E_i t_i} + \frac{1}{E_o t_o} \right).$$

Therefore

$$\gamma_{\max} = 0.089.$$

This indicates that the adhesive will be elastic near the crack. Also, the maximum adhesive shear strain is below the allowable strain $\gamma_{\max} < 0.8(\gamma_e + \gamma_p)$.

For elastic behaviour in the adhesive, the stress intensity in the repaired metallic structure is given by

$$K_{\infty} = \sigma_o \sqrt{\frac{E_i t_i \lambda \eta}{G}}.$$

Therefore

$$K_{\infty} = 12.2 \text{ MPa}\cdot\text{m}^{1/2}.$$

This is below the room temperature fracture toughness of the wing-skin material of $91.7 \text{ MPa}\cdot\text{m}^{1/2}$.

Peel stresses in adhesive bonds are induced by load path eccentricity. The maximum peel stress in the adhesive is given by

$$\sigma_{c_{\max}} = \tau_p \left(\frac{3E'_c t_o (1 - \nu^2)}{E_o \eta} \right)^{\frac{1}{4}}$$

where E'_c is the effective transverse stiffness of the adhesive system and for joints between dissimilar materials, is approximated by

$$\frac{1}{E'_c} = \frac{1}{E_c} + \frac{2}{E_i} + \frac{4}{E_o}$$

where E_c is the tensile elastic modulus of the adhesive, and is approximated by

$$E_c = 2G(1 + \nu).$$

$$\sigma_{c_{\max}} = 18.7 \text{ MPa}.$$

This is below the peel stress allowable that is conservatively approximated for FM73 as σ_p . Also, it is important to note that the peel stress concentration in the adhesive at the end of the repair is reduced significantly by tapering the ends of the repair [7].

The structural integrity of the composite patch is given by

$$\sigma_p = \frac{\sigma_{ep} t_i}{t_o} = 506 \text{ MPa}.$$

This implies a strain of

$$\varepsilon = \frac{\sigma_p}{E_o} = 0.0024.$$

This is below the failure strain for the boron epoxy composite of 0.0067.

Evaluate the fatigue susceptibility of the repair and structure.

The fatigue stress is very conservatively approximated as

$$\sigma_f = \sigma_{II} = 160 \text{ MPa} .$$

The fatigue stress in the metal skin at the end of the patch is given by

$$\sigma_{epf} = \Omega_L \sigma_f .$$

$$\sigma_{epf} = 192 \text{ MPa} .$$

Comparing this to SN data described in [8] for the 2024 T3 aluminium alloy (for a alternating stress of 192 MPa and assuming a mean stress of zero) we get a fatigue life of approximately 250000 cycles. The strain gauge data indicates that the wing-skin is loaded at a much lower level than assumed above and thus it is believed that the fatigue life of the wing-skin will not be compromised by the application of the patch.

The stress under the repair is given by

$$\sigma^{\#} = \frac{E_i t_i + \sigma_{epf}}{(E_o t_o + E_i t_i)}$$

and the maximum adhesive shear strain is given by

$$\gamma_{\max} = \frac{\sigma^{\#} t_i \lambda}{G} .$$

Therefore

$$\gamma_{\max} = 0.051 .$$

This indicates that the adhesive will be elastic and the maximum adhesive shear strain is below the allowable strain ($\gamma_{\max} < 2\gamma_e$).

For elastic behaviour in the adhesive, the stress intensity in the repaired metallic structure is given by

$$K_{\infty} = \sigma^{\#} \sqrt{\frac{E_i t_i \lambda \eta}{G}} .$$

Therefore

$$K_{\infty} = 7.06 \text{ MPa} . \text{m}^{1/2} .$$

For the 2024 T3 wing-skin aluminium alloy, Reference 8 gives a crack growth rate of approximately 0.00002 mm per cycle at a stress intensity 7.06 MPa.m^{1/2}. The above indicates that very slow crack growth may continue after repair, however, it should be emphasised that conservative loads have been used in this analysis and it is expected that in fact no crack growth will occur after repair. To ensure the effectiveness of the repair, it is recommended that the crack be periodically Non-Destructively Inspected by eddy currents until sufficient confidence is gained that crack growth has ceased.

Calculate the required patch dimensions

The repair transfer length is the minimum bond length required to transfer load into the patch. The transfer length is required to be large enough to carry load at the un-notched yield stress of the metal. The transfer length is calculated as the sum of the required plastic zone (l_p) to transfer material ultimate stress [3] and the elastic zone (l_e) necessary to ensure creep resistance. For this repair to minimize the stress concentration at the ends of the patch a logarithmic taper scheme as detailed in Reference 7 was used.

The load transfer length is given by

$$L_T = l_p + l_e = \frac{\sigma_u t_i}{2\tau_p} + \frac{3}{\lambda} = 34.4mm.$$

Normally the overlap length is equal to $2L_T$ and is the distance from the crack to the edge of the repair. For this repair, in which logarithmic tapering of patch is implemented, the overlap length is L_T plus the twice the taper length. The taper length is estimated initially by calculation of the first ply step length x as follows [7]:

$$x = \frac{5}{\lambda} = 18mm.$$

The step lengths of the remaining plies form approximately a logarithmic sequence. Such a stepping scheme, however, would result in a prohibitively long patch for this application. The location of cutouts in the wing-skin and associated rivets can also dictate that the maximum patch length. Given these restraints and that the smallest practical step length was 3mm, the following stepping scheme was proposed:

Ply #	1	2	3	4	5	6	7	8	9	10
Step Length (mm)	11	7	4	3	3	3	3	3	3	-

Thus the total taper length $L_{Taper} = 40\text{mm}$ and the minimum patch length is given by

$$L_p = 2L_{Taper} + 2L_T = 150\text{mm}.$$

Such a scheme implements the logarithmic stepping advocated in Reference 7 and so results in low adhesive stresses at the tapered ends. The initial step length satisfies the following relation:

$$x = \frac{3}{\lambda} = 11\text{mm}$$

The minimum patch width (L_w) is

$$L_w = 2 \times 12.7 + \text{defect}.$$

It was decided to make all the patches the same size to simplify manufacture and thus the largest defect size (17.5 mm crack plus 6.35 mm diameter hole) was used to determine the patch width. This gives a L_w of 50mm. To avoid rivets, a patch width of 55mm and a patch length of 160mm were chosen.

In summary:

$$L_p = 160\text{mm} \text{ and } L_w = 55\text{mm}.$$

Figure 8 is a schematic drawing of the patch.

A.3. Repair application

The repair is to be manufactured and applied in accordance with the procedures outlined in Reference 3.

DISTRIBUTION LIST

A Compendium of Bonded Repairs Applied to the PC9/A Full Scale Fatigue Test
Article During Testing

Richard Bartholomeusz, Rowan Geddes and Peter Chalkley

AUSTRALIA

DEFENCE ORGANISATION

Task Sponsor

DGTA
OIC ASI
ASI - SRS at RAAF Amberley

S&T Program

Chief Defence Scientist
FAS Science Policy
AS Science Corporate Management
Director General Science Policy Development
Counsellor Defence Science, London (Doc Data Sheet)
Counsellor Defence Science, Washington (Doc Data Sheet)
Scientific Adviser to MRDC Thailand (Doc Data Sheet)
Scientific Adviser Policy and Command
Navy Scientific Adviser (Doc Data Sheet and distribution list only)
Scientific Adviser - Army (Doc Data Sheet and distribution list only)
Air Force Scientific Adviser
Director Trials

} shared copy

Aeronautical and Maritime Research Laboratory

Director

Chief, Airframes and Engines Division
RLACS
RLSI
Richard Chester
Ray Parker
Ian Anderson
Peter Chalkley,
Richard Bartholomeusz,
Rowan Geddes

DSTO Library and Archives

Library Fishermans Bend (Doc Data Sheet)
Library Maribyrnong (Doc Data Sheet)
Library Salisbury (1 copy)
Australian Archives
Library, MOD, Pyrmont (Doc Data sheet only)
Library, MOD, HMAS Stirling

US Defense Technical Information Center, 2 copies
UK Defence Research Information Centre, 2 copies
Canada Defence Scientific Information Service, 1 copy
NZ Defence Information Centre, 1 copy
National Library of Australia, 1 copy

Capability Development Division

Director General Maritime Development (Doc Data Sheet only)
Director General C3I Development (Doc Data Sheet only)
Director General Aerospace Development

Army

ABCA Standardisation Officer, Puckapunyal, (4 copies)
SO (Science), DJFHQ(L), MILPO Enoggera, Queensland 4051 (Doc Data Sheet only)
NAPOC QWG Engineer NBCD c/- DENGERS-A, HQ Engineer Centre Liverpool Military Area, NSW 2174 (Doc Data Sheet only)

Air Force

ARDU (CO MAINTSQN) at RAAF Edinburgh SA
TFLSQN (CENGR) at RAAF Williamtown NSW
ALLMSQN (CENGR) at RAAF Richmond NSW
SRLSQN (CENGR) at RAAF Amberley QLD
MPLMSQN (CENGR) at RAAF Edinburgh SA
ARMYLSQN (CENGR) at Oakey QLD
TALMSQN (CENGR) at RAAF East Sale VIC
481 WG (OICAMF) at RAAF Williamtown NSW

Intelligence Program

DGSTA Defence Intelligence Organisation
Defence Intelligence Organisation-Information Centre

Corporate Support Program

Library Manager, DLS-Canberra (Doc Data Sheet)

UNIVERSITIES AND COLLEGES

Australian Defence Force Academy
Library
Head of Aerospace and Mechanical Engineering
Serials Section (M list), Deakin University Library, Geelong, 3217
Senior Librarian, Hargrave Library, Monash University (Doc Data Sheet only)
Librarian, Flinders University

OTHER ORGANISATIONS

NASA (Canberra)
AusInfo

OUTSIDE AUSTRALIA

ABSTRACTING AND INFORMATION ORGANISATIONS

Library, Chemical Abstracts Reference Service
Engineering Societies Library, US
Materials Information, Cambridge Scientific Abstracts, US
Documents Librarian, The Center for Research Libraries, US

INFORMATION EXCHANGE AGREEMENT PARTNERS

Acquisitions Unit, Science Reference and Information Service, UK
Library - Exchange Desk, National Institute of Standards and Technology, US
National Aerospace Laboratory, Japan
National Aerospace Laboratory, Netherlands

SPARES: 6

Total number of copies: 63

DEFENCE SCIENCE AND TECHNOLOGY ORGANISATION DOCUMENT CONTROL DATA				1. PRIVACY MARKING/CAVEAT (OF DOCUMENT)	
2. TITLE A Compendium of Bonded Repairs Applied to the PC9/A Full Scale Fatigue Test Article During Testing			3. SECURITY CLASSIFICATION (FOR UNCLASSIFIED REPORTS THAT ARE LIMITED RELEASE USE (L) NEXT TO DOCUMENT CLASSIFICATION) Document (U) Title (U) Abstract (U)		
4. AUTHOR(S) Richard Bartholomeusz, Rowan Geddes and Peter Chalkley			5. CORPORATE AUTHOR Aeronautical and Maritime Research Laboratory PO Box 4331 Melbourne Vic 3001 Australia		
6a. DSTO NUMBER DSTO-TN-0324		6b. AR NUMBER AR-011-653		6c. TYPE OF REPORT Technical Note	7. DOCUMENT DATE November 2000
8. FILE NUMBER M1/9/764	9. TASK NUMBER AIR00/145	10. TASK SPONSOR DGTA	11. NO. OF PAGES 24		12. NO. OF REFERENCES 8
13. URL ON THE WORLD WIDE WEB http://www.dsto.defence.gov.au/corporate/reports/DSTO-TN-0324.pdf				14. RELEASE AUTHORITY Chief, Airframes and Engines Division	
15. SECONDARY RELEASE STATEMENT OF THIS DOCUMENT <i>Approved for public release</i>					
OVERSEAS ENQUIRIES OUTSIDE STATED LIMITATIONS SHOULD BE REFERRED THROUGH DOCUMENT EXCHANGE, PO BOX 1500, SALISBURY, SA 5108					
16. DELIBERATE ANNOUNCEMENT No Limitations					
17. CASUAL ANNOUNCEMENT Yes					
18. DEFTEST DESCRIPTORS Bonded composite repairs, Composite materials, Fatigue tests, Fuselages, Cracking (Fracturing), PC9/A aircraft					
19. ABSTRACT A number of bonded composite repairs were applied to the PC9/A full-scale fatigue test article during its fatigue test to help achieve the target of greater than 50,000 simulated flight hours. The aim of the test was to provide RAAF with data to enable the through-life structural fatigue management of PC9/A aircraft in their fleet. Bonded repairs were applied to cracks that occurred in the wing centre-section on the lower wing skin and in the fuselage skin near the tail fin. The repairs were successful in stopping crack growth in the skin without affecting stresses in the underlying spars, which was critical in allowing proper lifing calculations. This report lists all the bonded composite repairs applied and for each repair, details its location, geometry and design and application notes. While the repairs were applied primarily to assist the smooth running of the fatigue test some of the repairs provide a starting point for design of future repairs to RAAF aircraft should cracking occur at the same locations.					