

Active Antenna Design Concept Using Microwave Power Modules

Phase I SBIR

Final Report

Contract # N00164-98-C-0037

Prepared By

**Mission Research Corporation
Antennas, Radomes, and Materials Division
3975 Research Boulevard
Dayton, Ohio 45430**

John Burke, Ph.D., P.E.

Distribution Statement

Approved for Public Release: Distribution is Unlimited.

20010315 141

Section 1 Executive Summary

Background

The Shipboard Active Array (SBAA) is used for both transmitting and receiving CEC communications. The baseline installation of the SBAA uses one antenna. However, for certain platforms a two-antenna configuration may be required due to structural blockage. Using two SBAA systems for one platform means that the acquisition costs are effectively doubled. Therefore, an alternative system is needed that achieves full performance with a lower procurement cost.

The CEC Shipboard Planar Antenna (SBPA) concept was conceived out of the need for a lower cost alternative to the SBAA. The SBPA concept configures two planar arrays with one common set of microwave power modules.

Purpose

This report presents the results of the SBIR effort entitled "Active Antenna Design Concept Using Microwave Power Modules". The objective of this project was to develop a preliminary design of two planar arrays that will be integrated with one common set of microwave power modules.

Summary of Results

In this document, we present the results of the six-month Phase I SBIR effort. During Phase I of the SBIR effort four different radiating elements were investigated as possible candidates for the proposed planar phased array. The first radiator, a printed dipole, will be shown to have very good scan performance but it requires the elements to be tightly packed. The T-bar fed slot radiator will be shown to be well matched over the frequency band of interest, but its scan performance was not yet been characterized. The remaining radiators, microstrip patch with a U-shaped slot and the microstrip stacked-patch, require several layers of dielectric material to achieve the required bandwidth. The presence of the dielectric layers will result in scan blindness due to the TM_0 surface wave mode. To reduce the generation of the TM_0 surface wave mode these radiators should be enclosed in a cavity backed architecture.

A preliminary design of an FSS band pass radome was also completed for the Phase I effort. The FSS band pass radome is an A-Sandwich with quartz/cyanate-ester skins, cyanate-ester bonding film, and glass/phenolic honeycomb core. These materials are suitable for the structural and environmental conditions and also exhibit excellent electrical properties.

Section 2 Description of Progress

Introduction

The preliminary design of a planar phased array antenna that can be integrated with Microwave Power Modules (MPM) was studied. The array will be scan compensated to maximize the scan volume while minimizing the scan loss. The array will consist of cavity backed radiators with SMA connectors on the back plane and a FSS radome. The array, not including the microwave power modules, will be very thin (~ 1.5 in.) and easily adaptable to a conformal installation. The array, when manufactured, will contain all of the passive components (radiating elements, radome and feed lines) in a rugged enclosure. The planar array and the enclosure are shown in Figures 1 and 2, respectively.

Background

The Shipboard Active Array (SBAA) is used for both transmitting and receiving CEC communications. The baseline installation of the SBAA uses one antenna. However, for certain platforms a two-antenna configuration may be required due to structural blockage. Using two SBAA systems for one platform means that the acquisition costs are effectively doubled. Therefore, an alternative system is needed that achieves full performance with a lower procurement cost.

The CEC Shipboard Planar Antenna (SBPA) concept was conceived out of the need for a lower cost alternative to the SBAA. The SBPA concept configures two planar arrays with one common set of microwave power modules. The SBPA concept is illustrated in Figure 3.

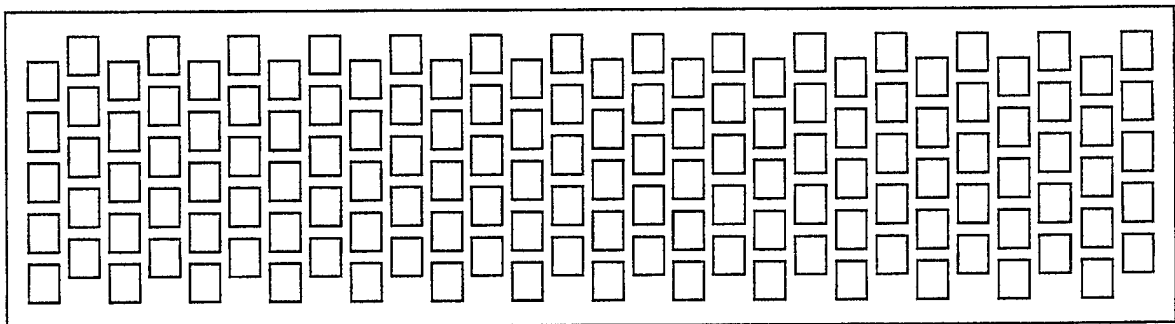

Figure 1. Front face of the planar phased array.

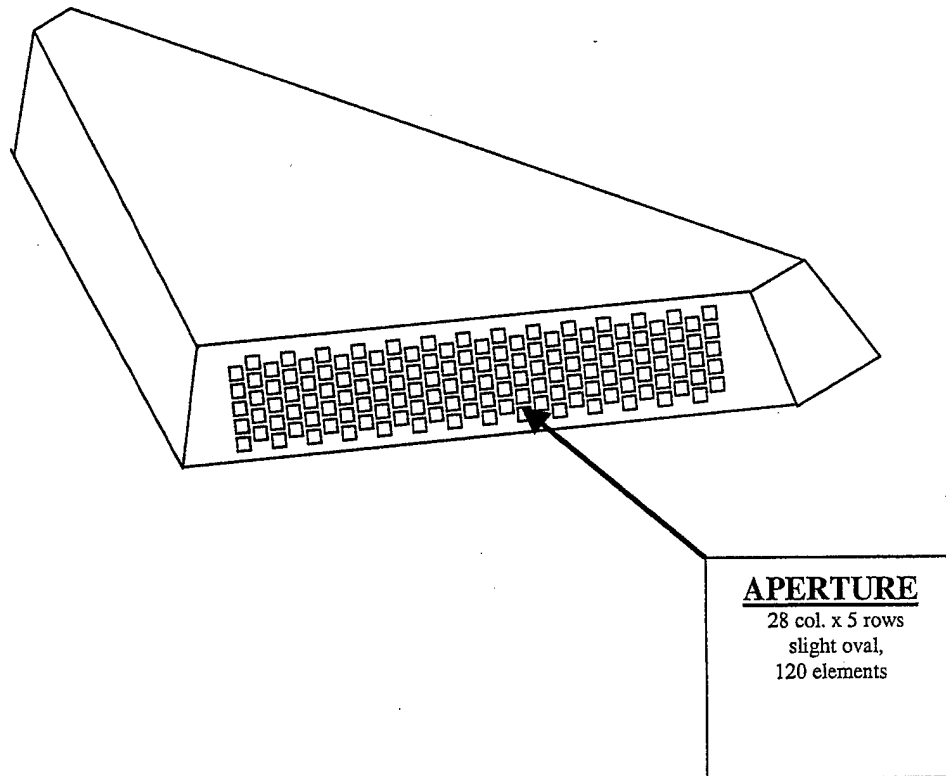

Figure 2. 3D view of the planar array enclosure.

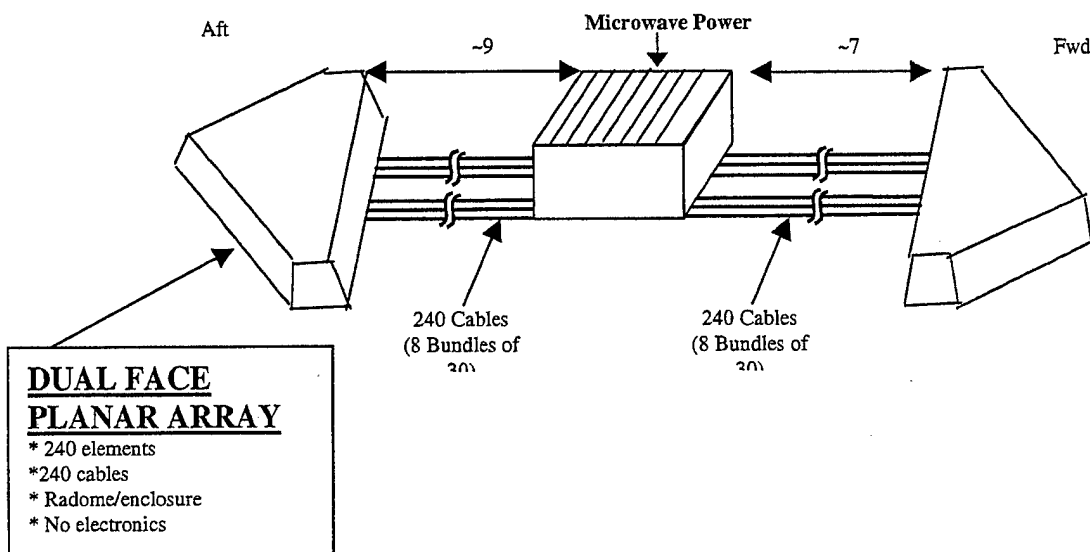

Figure 3. Schematic of the Shipboard Planar Array (SBPA) concept. The SBPA concept consists of two planar arrays (aft and forward) using one common set of microwave power modules.

Section 3

Phase I Results

Radiating Element Design

During Phase I of the SBIR the following radiating elements were investigated as possible candidates for the proposed planar phased array.

1. Printed Dipole
2. T-Bar Fed Slot
3. Microstrip Patch with U-shaped slot
4. Microstrip Stacked-Patch

PRINTED DIPOLE

The first element studied was an array of printed dipoles. The printed dipole array was chosen first because it can be manufactured by standard printed circuit techniques. The use of printed circuit techniques means that the array could be mass-produced at a low cost. The array, when manufactured, will contain all of the passive components (radiating elements, feed lines and balun) in a thin, rugged, monolithic package that combines multi-layer microwave printed circuitry with composite materials.

An array of printed dipoles was designed to operate over the bandwidth f_1 to f_2 . The lower frequency limit, f_1 , is defined as $f_1 = f_0 - \Delta_f/2$ and the upper frequency limit, f_2 , is defined as $f_2 = f_0 + \Delta_f/2$. The radiating aperture consists of a PTFE substrate surrounded by several layers of low-density foam. These layers are bonded together using a cyanate ester bonding film. The radiating elements are printed on the PTFE substrate. A $\lambda/4$ thick low-density foam separates the PTFE substrate from the ground plane. Attached to the front face of the dipoles is a layer of low-density foam. This superstrate forms the basis of a technique called wide-angle impedance matching (WAIM). WAIM is employed to scan compensate the array.

The cross-section of the optimized array is shown in Figure 4 and the top view is shown in Figure 5. The printed dipole array was simulated using PMM. PMM is a powerful full-wave technique based on the Floquet plane wave expansion (PWE) and the method of moments (MOM). The results of the simulation are shown in Figure 6. The match is better than -20 dB over most of the bandwidth (f_1 to f_2).

The mismatch gain for the optimized array is shown in Figure 7. Note the mismatch gain is better than -0.1 dB over the whole bandwidth. The scan gain for scanning in the E and H planes is shown in Figures 8 and 9, respectively. The scan gain for the H plane is better than $\cos^{1.25} \theta_0$ over the whole bandwidth except for the high end of the band near 45 degrees.

The performance of the printed dipole is very good. However, the printed dipole is in a lattice, 1.4" by 1.1", which is somewhat smaller than the desired lattice spacing, 1.4" by 1.28". It does not appear that a dipole array can be designed using the desired lattice spacing and meet the specifications for gain and frequency bandwidth.

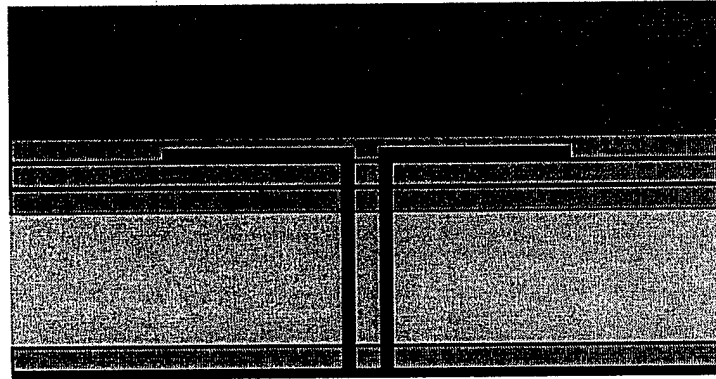

Figure 4. Cross-section of the printed circuit dipole array.

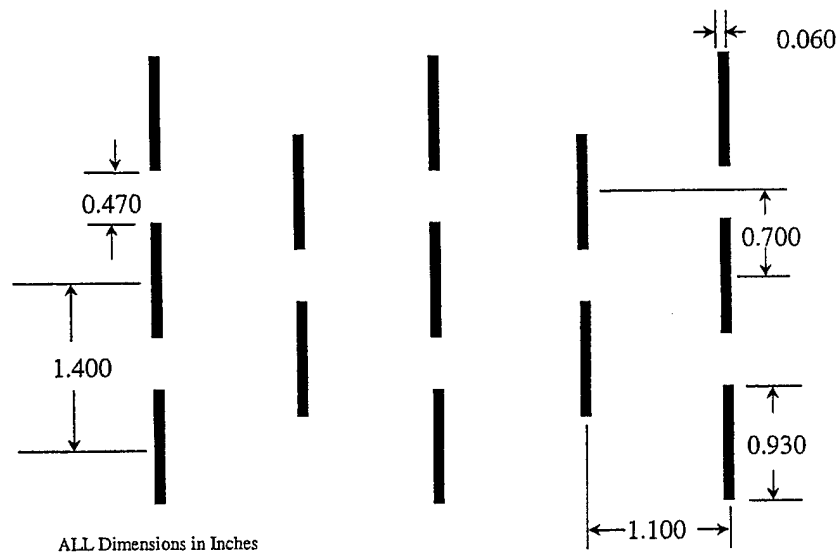

Figure 5. Top view of printed dipole array.

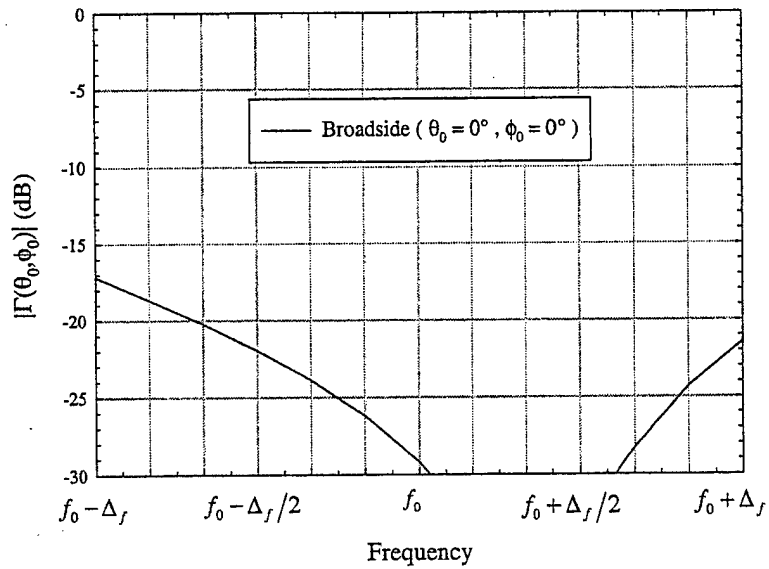

Figure 6. Simulated reflection coefficient for the printed dipole array.

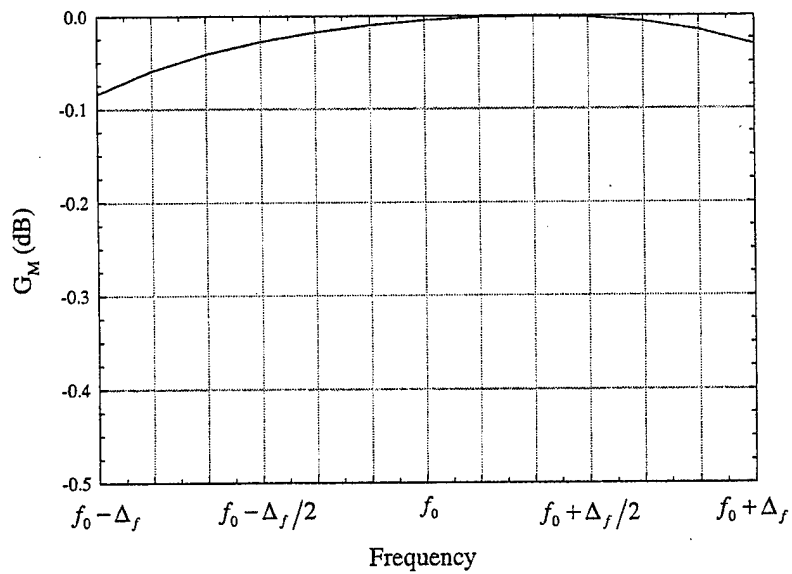

Figure 7. Simulated mismatch gain for the printed dipole array.

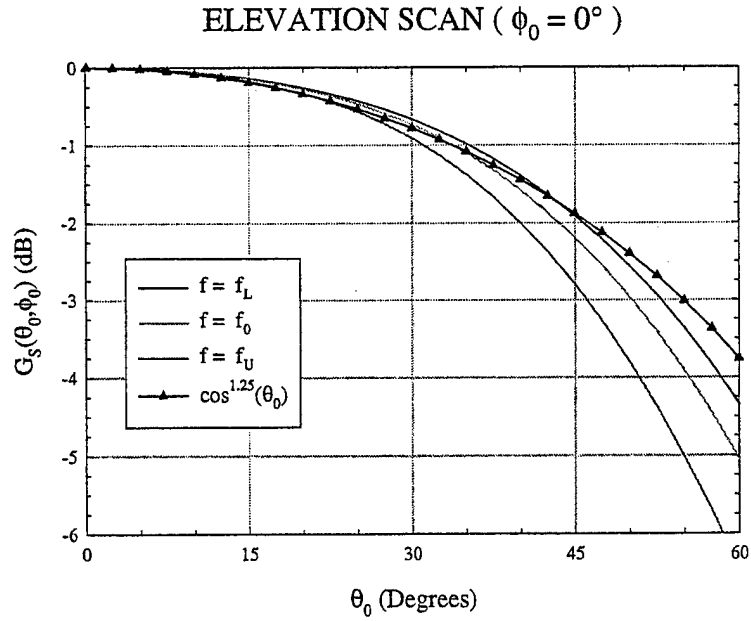

Figure 8. Simulated scan gain as a function of the elevation angle (θ_0) for the printed dipole array.

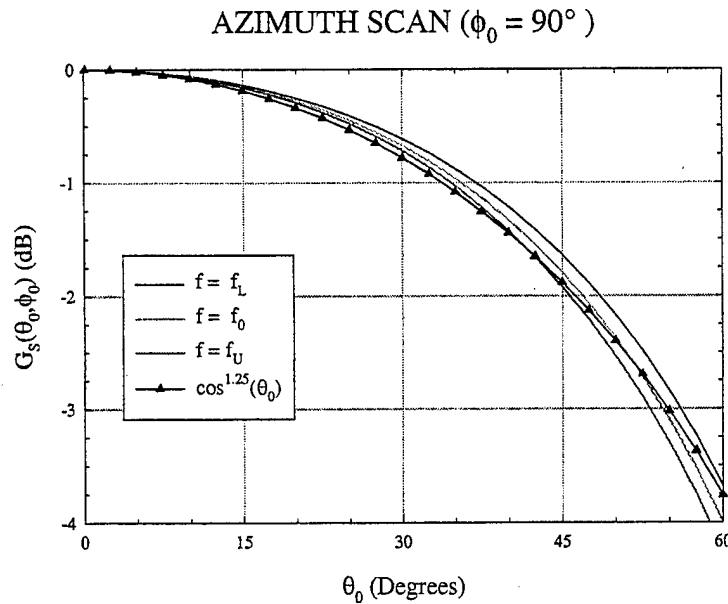

Figure 9. Simulated scan gain as a function of the azimuth angle (θ_0) for the printed dipole array.

T-BAR FED SLOT

The second radiator under consideration is a cavity-backed slot antenna. Cavity-backed slot antennas are very easy to fabricate and have some very nice scan characteristics. However, the driving point impedance of a cavity-backed slot radiator is usually very high (greater than several hundred Ohms). Feeding the cavity with a T-bar can reduce the driving point impedance to more manageable levels. A T-bar fed slot antenna is shown in Figure 10.

A single element T-bar fed slot antenna was designed to operate over the bandwidth f_1 to f_2 . The lower frequency limit, f_1 , is defined as $f_1 = f_0 - \Delta_f/2$ and the upper frequency limit, f_2 , is defined as $f_2 = f_0 + \Delta_f/2$. In addition to the single element, an infinite array of T-bar fed slot antennas was designed. The single element and infinite array were simulated using HFSS. HFSS is a full-wave electromagnetic simulator employing the finite element method used to simulate 3-D antennas. The simulated reflection coefficient and mismatch gain of the infinite array is shown in Figures 11 and 12, respectively. The match is better than -10 dB over most of the bandwidth.

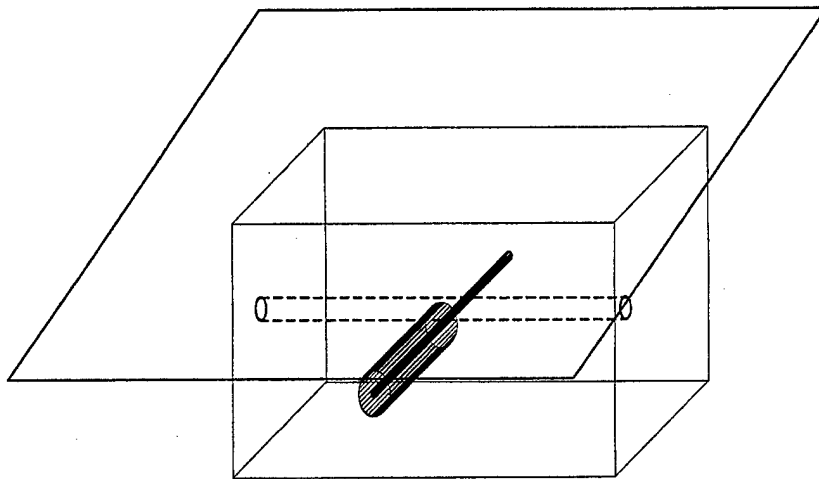

Figure 10. Perspective view of a T-bar fed slot radiator.

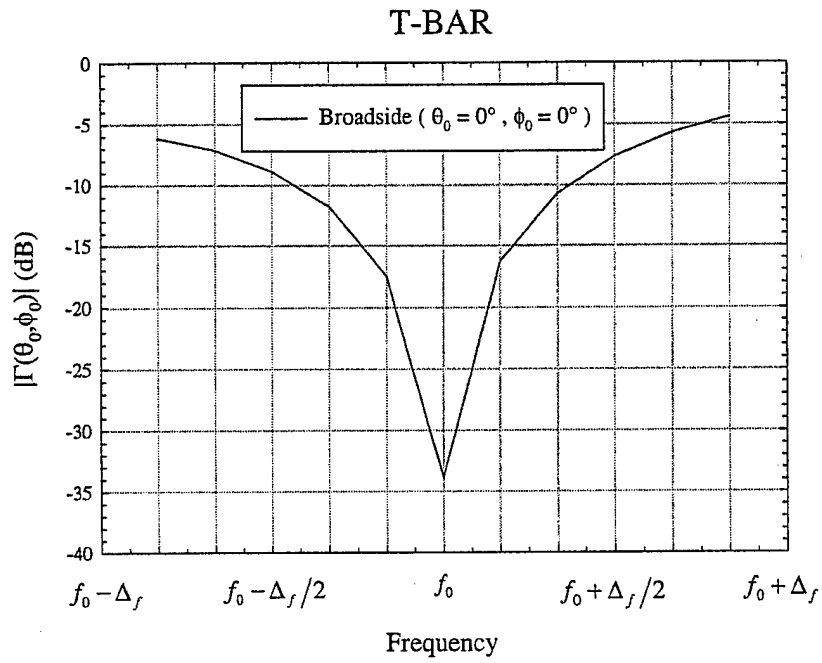

Figure 11. Simulated reflection coefficient for the T-bar fed slot array.

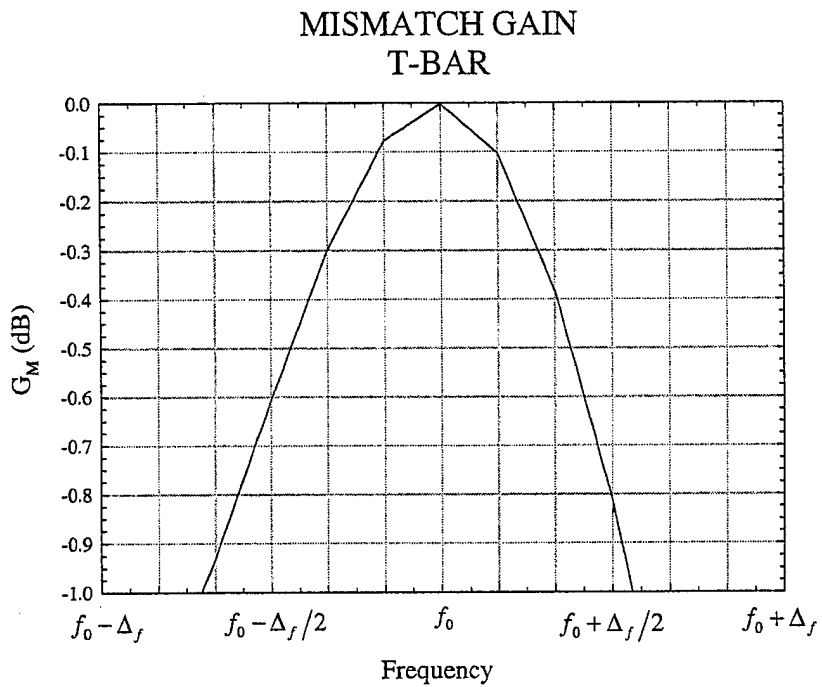

Figure 12. Simulated reflection coefficient for the T-bar fed slot array.

MICROSTRIP PATCH

A microstrip patch antenna is another type of radiator that was being considered for the Phase I effort. One drawback with the microstrip patch is that it has a bandwidth on the order of 3%. There are many ways of extending the bandwidth of a microstrip patch. One technique is to place a U-shaped slot on the conducting surface of the patch. Another technique to extend the bandwidth is to use two microstrip patches in a stack. These types of radiators will be discussed next.

MICROSTRIP PATCH WITH A U-SHAPED SLOT

The third type of radiator under consideration is a microstrip patch with a U-shaped slot. A probe-fed microstrip patch with a U-shaped slot has been shown to achieve a frequency bandwidth on the order of 40%. The top and side views of a microstrip patch with a U-shaped slot are shown in Figures 13 and 14, respectively.

A single element microstrip patch with a U-shaped slot was designed to operate over the bandwidth f_1 to f_2 . The lower frequency limit, f_1 , is defined as $f_1 = f_0 - \Delta_f/2$ and the upper frequency limit, f_2 , is defined as $f_2 = f_0 + \Delta_f/2$. The single element microstrip patch with a U-shaped slot was simulated using Ensemble. Ensemble is a full-wave electromagnetic simulator employing the method of moments and is used to simulate planar antennas. The simulated reflection coefficient and mismatch gain is shown in Figures 15 and 16, respectively. The match is better than -10 dB over most of the bandwidth.

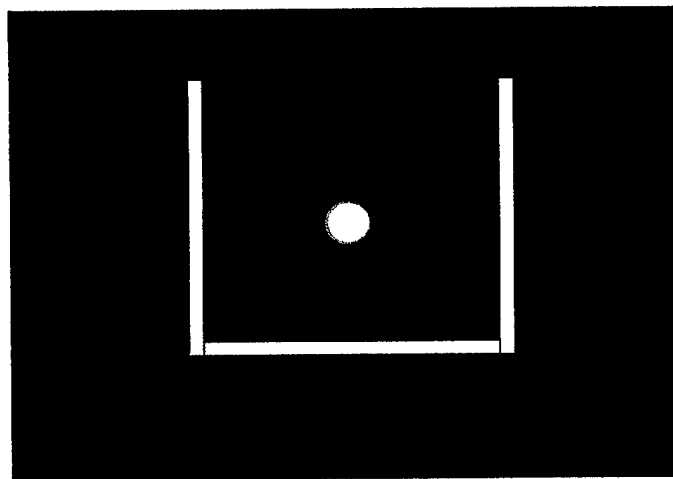

Figure 13. Top view of the microstrip patch with a U-shaped slot.

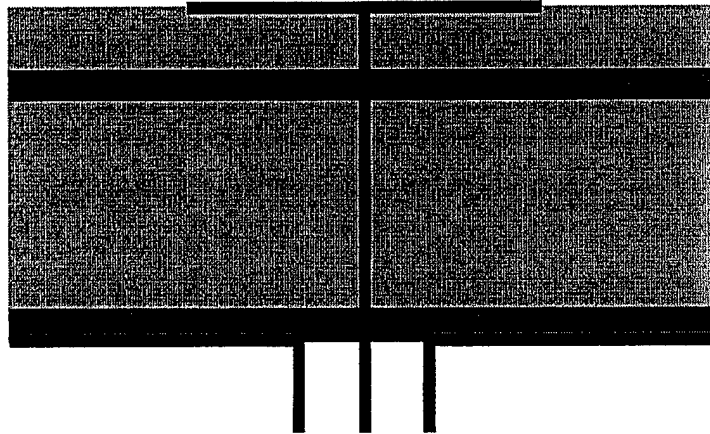

Figure 14. Cross-section of the microstrip patch with U-shaped slot.

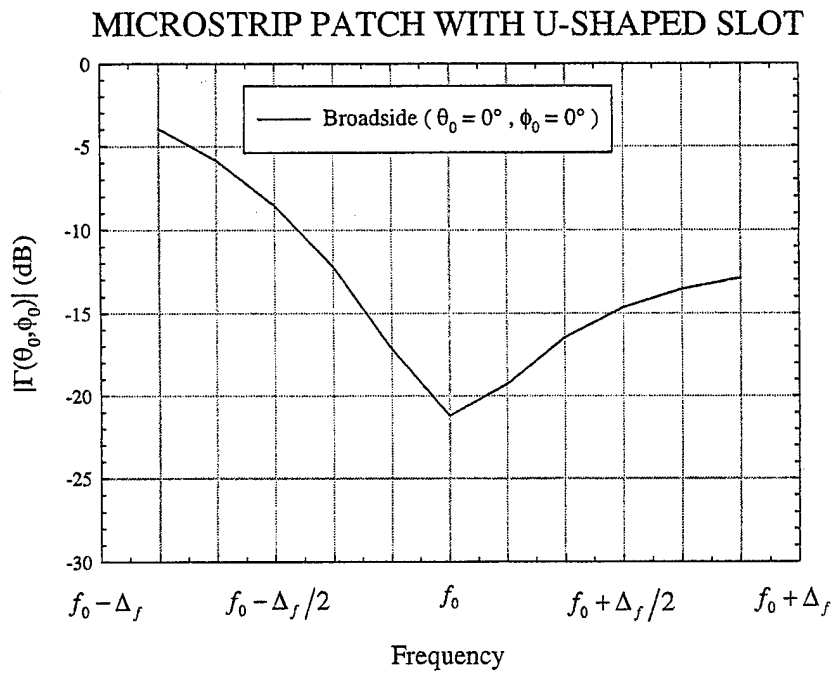

Figure 15. Simulated reflection coefficient for the microstrip patch with U-shaped slot.

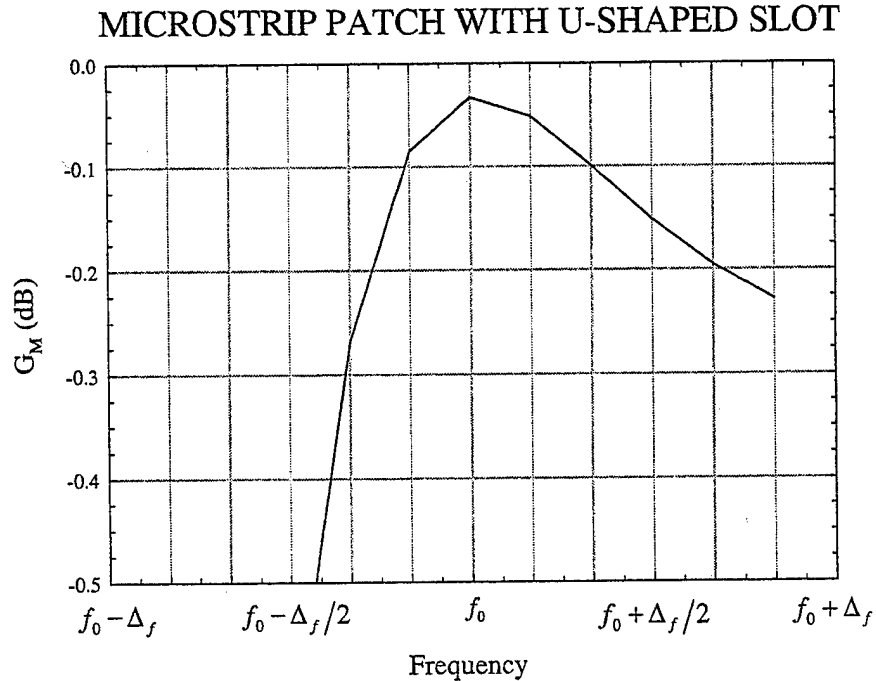

Figure 16. Simulated mismatch gain of the microstrip patch with U-shaped slot.

MICROSTRIP STACKED-PATCH

The fourth and final type of radiator under consideration is a microstrip stacked-patch. As mentioned above, using two microstrip patches in a stack can extend the bandwidth of a patch. The microstrip stacked-patch consists of a patch printed on the front face of the antenna substrate and a patch printed on the bottom face of the antenna superstrate. There is a low permittivity layer separating the substrate and superstrate. This type of radiator in conjunction with scan compensation would have a good chance of meeting the SBPA specifications.

There are two methods for feeding the stacked microstrip patch. The first method uses a probe. This feeding technique is shown in Figure 17. However, the probe feed requires a plated through hole that can introduce some tolerance stack up problems in a very large array. Using a fuzz button instead of the plated through hole should alleviate some of the tolerance stack up. The second method is to use a microstrip line to feed the stacked-patches through an aperture in the ground plane. This method is illustrated in Figure 18. The microstrip feed line is printed on the bottom side of the feed substrate. The feed line extends past the aperture approximately $\lambda_g/4$.

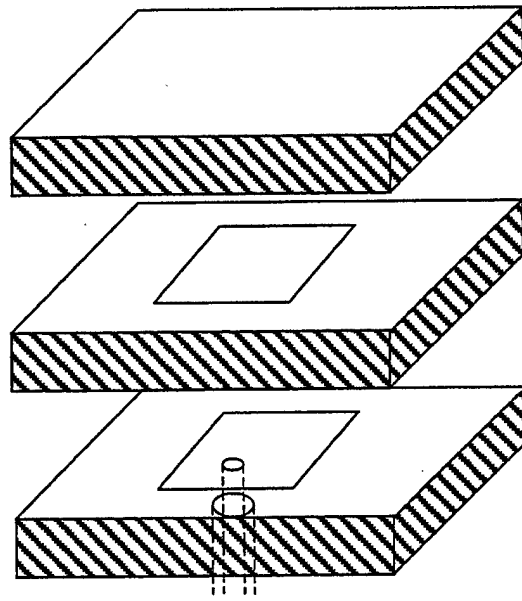

Figure 17. Perspective view of a probe-fed microstrip stacked-patch.

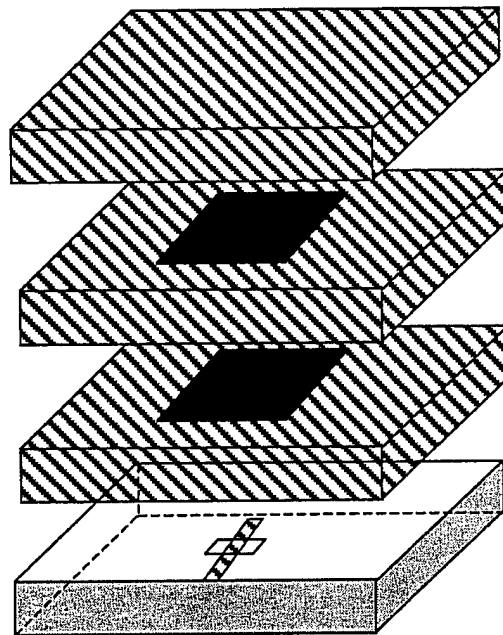

Figure 18. Perspective view of an aperture-coupled microstrip stacked-patch.

A single element aperture-coupled microstrip stacked-patch was designed to operate over the bandwidth f_1 to f_2 . The lower frequency limit, f_1 , is defined as $f_1 = f_0 - \Delta_f/2$ and the upper frequency limit, f_2 , is defined as $f_2 = f_0 + \Delta_f/2$. The single element aperture-coupled microstrip stacked-patch was simulated using Ensemble. The simulated reflection coefficient and mismatch gain is shown in Figures 19 and 20, respectively. The match is better than -20 dB over most of the bandwidth.

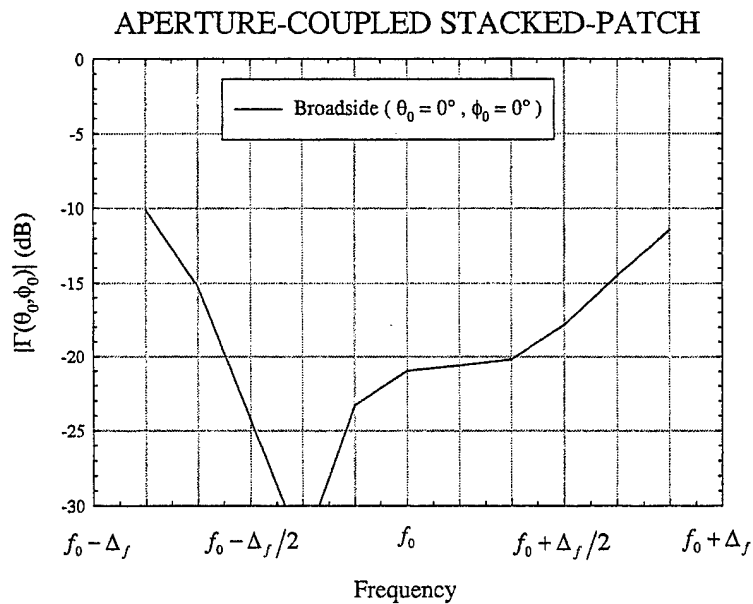

Figure 19. Simulated reflection coefficient for the aperture-coupled microstrip stacked-patch.

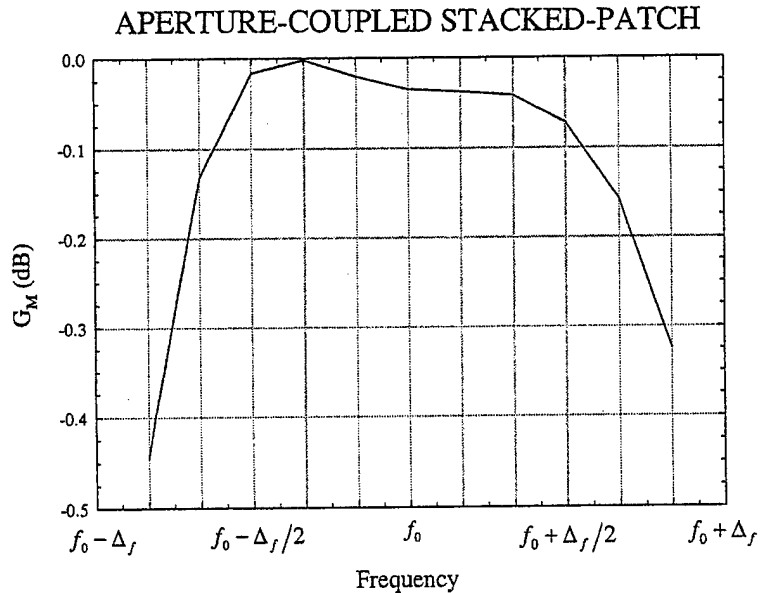

Figure 20. Simulated mismatch gain of the aperture-coupled microstrip stacked-patch.

Conclusion

In this section the design of the radiating element was discussed. Four different radiators were suggested as possible candidates for the SBPA. The first radiator, a printed dipole, has very good scan performance but it requires the elements to be tightly packed. The T-bar fed slot radiator is well matched over the frequency band of interest, but its scan performance has not yet been characterized. The remaining radiators, microstrip patch with a U-shaped slot and the microstrip stacked-patch, require several layers of dielectric material to achieve the required bandwidth. The presence of the dielectric layers will result in scan blindness due to the TM_0 surface wave mode. To reduce the generation of the TM_0 surface wave mode these radiators should be enclosed in a cavity backed architecture.

Radome Design

During Phase 1, a preliminary design of an FSS band pass radome was completed. Figures 21 through 24 show some of the details of this design. (Note: The information shown here represents a scaled version of the design.) Figure 21 shows a profile view of the radome wall design. This is an A-Sandwich with quartz/cyanate-ester skins, cyanate-ester bonding film, and glass/phenolic honeycomb core. These materials are suitable for the structural and environmental conditions and also exhibit excellent electrical properties. The FSS layers are embedded in the outer skin. Figure 22 shows the dipole FSS geometry and Figure 23 shows the slot FSS geometry. Figure 24 shows the calculated transmission coefficient of this design.

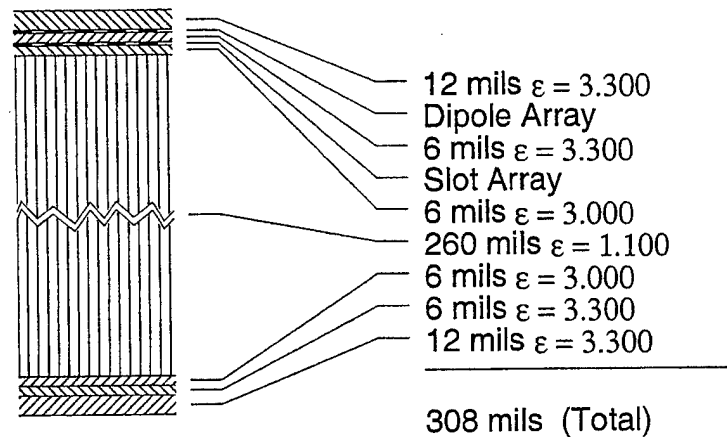

Figure 21. Profile view of radome wall design.

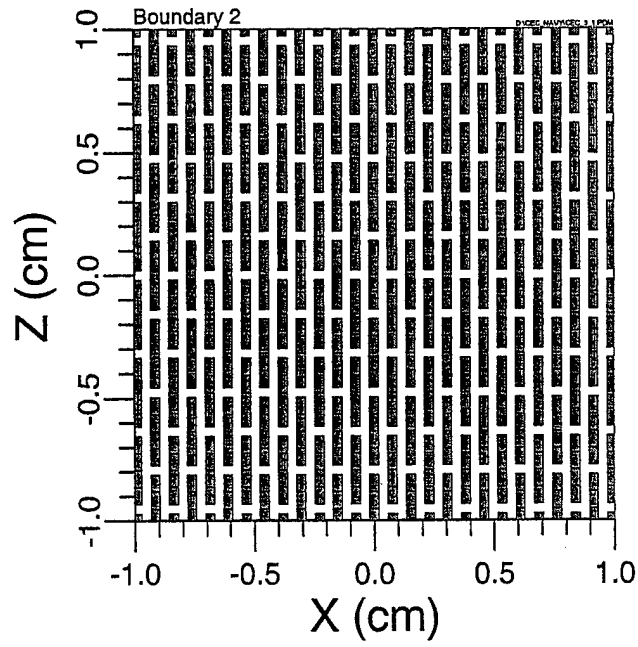

Figure 22. Planar view of the dipole FSS geometry.

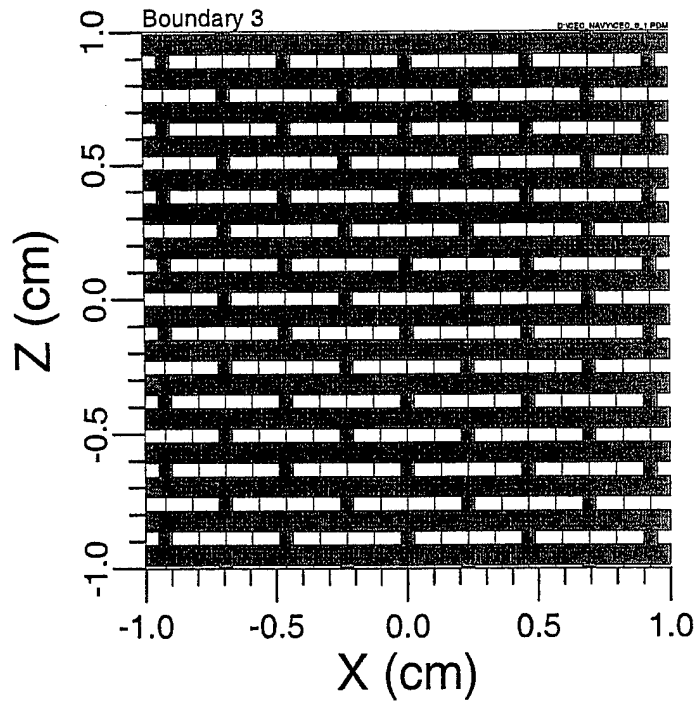

Figure 23. Planar view of the slot FSS geometry.

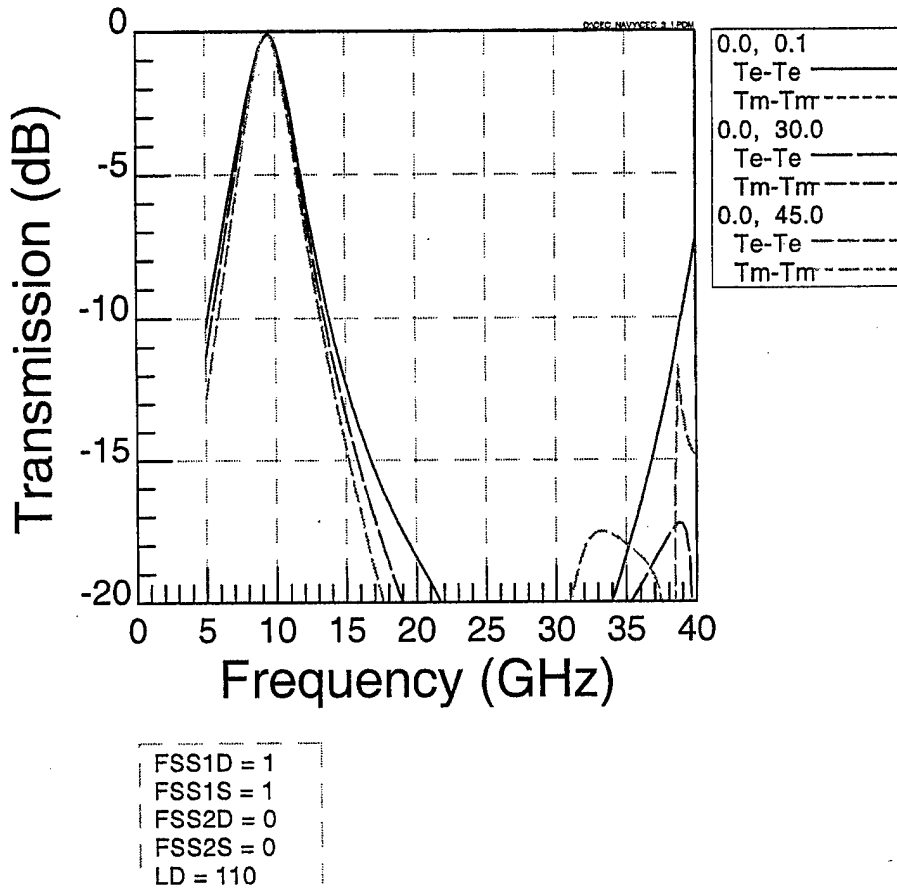

Figure 24. Simulated radome transmission coefficient.

Section 4

Summary and Recommendations

Summary

This report documents the results of the work conducted under the SBIR Phase I effort entitled "Active Antenna Design Concept Using Microwave Power Modules". The objective of this project was to develop a preliminary design of two planar arrays that will be integrated with one common set of microwave power modules. During Phase I of the SBIR effort four different radiating elements were investigated as possible candidates for the proposed planar phased array.

The first radiator, a printed dipole, has very good scan performance but it requires the elements to be tightly packed. The T-bar fed slot radiator is well matched over the frequency band of interest, but its scan performance has not yet been characterized. The remaining radiators, microstrip patch with a U-shaped slot and the microstrip stacked-patch, require several layers of dielectric material to achieve the required bandwidth. The presence of the dielectric layers will result in scan blindness due to the TM_0 surface wave mode. To reduce the generation of the TM_0 surface wave mode these radiators should be enclosed in a cavity-backed architecture.

A preliminary design of an FSS band pass radome was also completed for the Phase I effort. The FSS band pass radome is an A-Sandwich with quartz/cyanate-ester skins, cyanate-ester bonding film, and glass/phenolic honeycomb core. These materials are suitable for the structural and environmental conditions and also exhibit excellent electrical properties.

Recommendations

The results presented in this document show that the Phase I was very successful. Continuing this effort to develop an aperture for use in the CEC Shipboard Planar Antenna (SBPA) System is the logical next step. Therefore, we make the following recommendations for objectives in a Phase II effort:

1. Design a radiating element that is compatible with MPM technology.
2. Design a 120-element array consisting of scan compensated elements that meets the CEC specifications.
3. Design a radome incorporating an FSS.
4. Design the I/O interconnects and the internal cabling for the CEC SBPA.
5. Design an enclosure for the CEC SBPA.
6. Integrate two 120-element arrays, the radome, internal cabling and interconnects into the CEC SBPA enclosure.
7. Fabricate one forward and one aft prototype CEC SBPA.
8. Test the two prototype antennas.

Section 5 References

- [1] S.D. Targonski and R.B. Waterhouse, "Design of wide-band aperture-stacked patch microstrip antennas," *IEEE Trans. Antennas and Propagation.*, vol. 46, no. 9, pp.1245-1251, Sept. 1998
- [2] F. Croq and A. Papiernik, "Wide-band aperture coupled microstrip antenna," *Electron. Letters.*, vol. 26, pp.1293-1294, Aug. 1990
- [3] S.D. Targonski and D.M. Pozar, "Design of wide-band circularly polarized aperture coupled microstrip antennas," *IEEE Trans. Antennas and Propagation.*, vol. 41, pp-214-220, Feb. 1993
- [4] R.J. Mailloux, "On the use of metallized cavities in printed slot arrays with dielectric substrates," *IEEE trans. Antennas and Propagation.*, vol. AP-35,no 5, pp. 477-487, May 1997
- [5] E.H. Newman and Garry A. Thiele, "Some important parameters in the design of T-bar fed slot antennas," *IEEE Trans Antennas and Propagation.*, pp. 97-100, Jan. 1975
- [6] F. Zabosh and J.T. Aberle, "Infinite phased arrays of cavity backed patches," *IEEE Trans. Antennas and Propagation.*, vol. 42, no.3, pp. 390-398. Mar. 1994
- [7] K.F. Lee, K.M. Luk, et al, "Experimental Study of the Rectangular Patch with a U Shaped Slot," *IEEE APS Int. Sump.*, vol. 1, pp., 10-13, 1996
- [8] T. Huynh and K.F. Lee,"Single-layer single-patch wide-band microstrip antenna," *Electron. Letters.*, vol. 31, no. 16, pp.1312-1313, 1995