

AD _____

Award Number: DAMD17-97-1-7252

TITLE: Retinoids and Retinoid Metabolism in Breast Cancer

PRINCIPAL INVESTIGATOR: Jisun Paik
Karen Swisshelm, Ph.D.

CONTRACTING ORGANIZATION: University of Washington
Seattle, Washington 98105-6613

REPORT DATE: July 2000

TYPE OF REPORT: Final

PREPARED FOR: U.S. Army Medical Research and Materiel Command
Fort Detrick, Maryland 21702-5012

DISTRIBUTION STATEMENT: Approved for Public Release;
Distribution Unlimited

The views, opinions and/or findings contained in this report are those of the author(s) and should not be construed as an official Department of the Army position, policy or decision unless so designated by other documentation.

20010323 030

REPORT DOCUMENTATION PAGE

Form Approved
OMB No. 074-0188

Public reporting burden for this collection of information is estimated to average 1 hour per response, including the time for reviewing instructions, searching existing data sources, gathering and maintaining the data needed, and completing and reviewing this collection of information. Send comments regarding this burden estimate or any other aspect of this collection of information, including suggestions for reducing this burden to Washington Headquarters Services, Directorate for Information Operations and Reports, 1215 Jefferson Davis Highway, Suite 1204, Arlington, VA 22202-4302, and to the Office of Management and Budget, Paperwork Reduction Project (0704-0188), Washington, DC 20503

| | | | |
|-----------------------------------------------------------------------------------------------------------------------------------------------------------------------------------------------------------------------------------------------------------------------------------------------------------------------------------------------------------------------------------------------------------------------------------------------------------------------------------------------------------------------------------------------------------------------------------------------------------------------------------------------------------------------------------------------------------------------------------------------------------------------------------------------------------------------------------------------------------------------------------------------------------------------------------------------------------------------------------------------------------------------------------------------------------------------------------------------------------------------------------------------------------------------------------------------------------------------------------------------------------------------------------------------------------------------------------------------------------------------------------------------------------------------------------------------------------------------------------------------------------------------------------------------------------------------------------------------------------------------------------------|-----------------------------------------------------------------|--------------------------------------------------------------------------|------------------------------------------------|
| 1. AGENCY USE ONLY (Leave blank) | 2. REPORT DATE July 2000 | 3. REPORT TYPE AND DATES COVERED Final (16 Jun 97 - 15 Jun 00) | |
| 4. TITLE AND SUBTITLE Retinoids and Retinoid Metabolism in Breast Cancer | | 5. FUNDING NUMBERS DAMD17-97-1-7252 | |
| 6. AUTHOR(S) Jisun Paik Karen Swisshelm, Ph.D. | | 8. PERFORMING ORGANIZATION REPORT NUMBER | |
| 7. PERFORMING ORGANIZATION NAME(S) AND ADDRESS(ES) University of Washington Seattle, Washington 98105-6613 E-MAIL: jp867@columbia.edu | | | |
| 9. SPONSORING / MONITORING AGENCY NAME(S) AND ADDRESS(ES) U.S. Army Medical Research and Materiel Command Fort Detrick, Maryland 21702-5012 | | 10. SPONSORING / MONITORING AGENCY REPORT NUMBER | |
| 11. SUPPLEMENTARY NOTES | | | |
| 12a. DISTRIBUTION / AVAILABILITY STATEMENT Approved for public release; distribution unlimited | | | 12b. DISTRIBUTION CODE |
| 13. ABSTRACT (Maximum 200 Words) Retinoids play diverse roles in human physiology. Retinoid actions are mediated via retinoid receptors (RARs and RXRs). Little is known about the biosynthetic pathway of 9- <i>cis</i> -retinoic acid, the physiological ligand for RXRs. Thus, we studied <i>cis</i> -retinol dehydrogenase (cRDH), an enzyme that oxidizes <i>cis</i> -retinols, a first step needed for 9- <i>cis</i> -retinoic acid synthesis. LRDHSN/Hep G2 cells were developed to study the characteristics of cRDH and its role in 9- <i>cis</i> -retinoic acid synthesis. We observed that cRDH oxidizes 9- <i>cis</i> -retinol and follows Michaelis-Menten kinetics. Nonetheless, cRDH over-expression did not result in increased synthesis of 9- <i>cis</i> -retinoic acid, which likely arises from the inhibition of 9- <i>cis</i> -retinal oxidation by high concentrations of 9- <i>cis</i> -retinol <i>in vitro</i> . We also studied the role of cRDH in 9- <i>cis</i> -retinol metabolism and in cell proliferation of MCF7 cells, a human breast cancer line. We demonstrated that both cRDH and 9- <i>cis</i> -retinol treatment were required to bring about a growth inhibitory effect on MCF7 cells. This growth inhibition was not mediated by 9- <i>cis</i> -retinoic acid but by other 9- <i>cis</i> -retinol metabolites like 9- <i>cis</i> -retinal and/or an unknown metabolite. Our studies suggest that a two pronged approach of targeted gene therapy with cRDH in combination with a low dose of 9- <i>cis</i> -retinol treatment may be a useful breast cancer treatment. | | | |
| 14. SUBJECT TERMS Breast Cancer, Retinoids, Metabolism, Therapy, Nutrition, Chemoprevention | | | 15. NUMBER OF PAGES 63 |
| | | | 16. PRICE CODE |
| 17. SECURITY CLASSIFICATION OF REPORT Unclassified | 18. SECURITY CLASSIFICATION OF THIS PAGE Unclassified | 19. SECURITY CLASSIFICATION OF ABSTRACT Unclassified | 20. LIMITATION OF ABSTRACT Unlimited |

FOREWORD

Opinions, interpretations, conclusions and recommendations are those of the author and are not necessarily endorsed by the U.S. Army.

___ Where copyrighted material is quoted, permission has been obtained to use such material.

___ Where material from documents designated for limited distribution is quoted, permission has been obtained to use the material.

___ Citations of commercial organizations and trade names in this report do not constitute an official Department of Army endorsement or approval of the products or services of these organizations.

___ In conducting research using animals, the investigator(s) adhered to the "Guide for the Care and Use of Laboratory Animals," prepared by the Committee on Care and use of Laboratory Animals of the Institute of Laboratory Resources, national Research Council (NIH Publication No. 86-23, Revised 1985).

JP For the protection of human subjects, the investigator(s) adhered to policies of applicable Federal Law 45 CFR 46.

JP In conducting research utilizing recombinant DNA technology, the investigator(s) adhered to current guidelines promulgated by the National Institutes of Health.

JP In the conduct of research utilizing recombinant DNA, the investigator(s) adhered to the NIH Guidelines for Research Involving Recombinant DNA Molecules.

___ In the conduct of research involving hazardous organisms, the investigator(s) adhered to the CDC-NIH Guide for Biosafety in Microbiological and Biomedical Laboratories.

 July 20, 2000
PI - Signature Date

Table of Contents

| | |
|------------------------------------------|-----------|
| Cover..... | 1 |
| SF 298..... | 2 |
| Foreword..... | 3 |
| Table of Contents..... | 4 |
| Introduction..... | 5 |
| Body..... | 6 |
| Key Research Accomplishments..... | 11 |
| Reportable Outcomes..... | 13 |
| Conclusions..... | 14 |
| References..... | 15 |
| Appendices..... | 16 |

INTRODUCTION

The diverse roles of retinoids in vertebrate physiology include actions in the visual cycle and effect on epithelial cell differentiation and embryo development (1). Most of the functions of retinoids are mediated through the actions of specific nuclear retinoid receptors, retinoic acid receptors (RARs) and retinoid X receptors (RXRs), which regulate transcription of many down-stream genes. The known physiological ligand for the RARs is all-*trans*-retinoic acid and that for the RXRs is 9-*cis*-retinoic acid. 9-*Cis*-retinoic acid has been shown to be effective as a potential breast cancer treatment modality in tissue culture and animal models (2-4). At present, the *in vivo* synthesis pathways of 9-*cis*-retinoic acid are not well understood. Three hypothesized pathways of 9-*cis*-retinoic acid have been proposed. These are (1) oxidation of 9-*cis*-retinol; (2) isomerization of all-*trans*-retinoic acid; and (3) cleavage of 9-*cis*- β -carotene. My research was focused on the oxidation of 9-*cis*-retinol by *cis*-retinol dehydrogenase (cRDH) as a possible *in vivo* source of the RXR-ligand, 9-*cis*-retinoic acid. cRDH was first isolated from human mammary cDNA library and was found to be expressed at higher levels in a normal breast tissue compared to a breast cancer tissue (5). We hypothesized that cRDH may be involved in 9-*cis*-retinoic acid synthesis in normal mammary cells, but that breast cancer cells lack the capability to metabolize 9-*cis*-retinol to its active metabolite, 9-*cis*-retinoic acid. To study the role of cRDH in 9-*cis*-retinol metabolism, we developed two model cell lines that over-express cRDH, **LRDHS**H/Hep G2 and **LRDHS**N/MCF7 cells. The former was used to study the biochemical characteristics of cRDH, while the latter was utilized to delineate the pathways of 9-*cis*-retinol metabolism and the effect of 9-*cis*-retinoids on breast cancer cell growth. Employing these model systems, we have shown (1) that cRDH oxidize 9-*cis*-retinol to 9-*cis*-retinal *in vitro* and also in cultured cells; (2) that high concentrations of 9-*cis*-retinol are inhibitory for 9-*cis*-retinoic acid synthesis; (3) that cRDH, in combination with 9-*cis*-retinol treatment results in growth inhibition of MCF7 cells; and (4) that 9-*cis*-retinol metabolites, other than 9-*cis*-retinoic acid are responsible for the growth inhibition of MCF7 cells over-expressing cRDH.

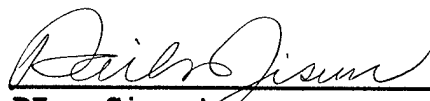
BODY

1. Biochemical characteristics of cRDH and 9-*cis*-retinoic acid synthesis pathway

The work included in this section was not proposed in the original grant, however, it was critical to perform experiments with hepatocytes before carrying out ensuing studies investigating the possible effect of cRDH and 9-cis-retinol on breast cancer cell growth. This work provides a basis for understanding my distinct work in breast cancer cells.

A series of studies were performed using stably transduced Hep G2, a human hepatoma cell line that over-expresses cRDH (**LRDHSN/Hep G2**) in order to characterize the properties of this enzyme and to understand its possible role in synthesis of 9-*cis*-retinoic acid. A detailed description of this work has been recently published (Paik *et al.* 9-*Cis*-retinoids: Biosynthesis of 9-*cis*-retinoic acid. Biochemistry 39:8073-8084, 2000 -- Appendix). A brief description of the study and my major findings are outlined below.

We wanted to study 9-*cis*-retinoic acid synthesis in a system where cRDH is endogenously expressed and where other factors and proteins that are involved in retinol metabolism are likely present. Since the liver plays critical role in retinol metabolism, liver-derived cells are the most suitable candidates for such studies. Hep G2 cells and HSC-T6 cells were chosen since they are derived from the two major cell types of the liver that participate in retinoid metabolism, hepatocytes and stellate cells, respectively. Both cell lines were cultured in either 9-*cis*- or all-*trans*-retinol and the types and the concentrations of retinoids accumulated by these cells over 5 h period were analyzed by high performance liquid chromatography (HPLC). We found that both cell types took up and metabolized 9-*cis*-retinol to 9-*cis*-retinyl esters and also 9-*cis*-retinoic acid. However, while the uptake of 9-*cis*-retinol by HSC-T6 cells was not affected by the presence of all-*trans*-retinol, 9-*cis*-retinol uptake by Hep G2 cells was hindered if all-*trans*-retinol was provided simultaneously. The significance of this finding, in terms of physiology, is not clear but the two cell types did take up and metabolize 9-*cis*-retinol in a manner that maintained the 9-*cis*-configuration. The capability of the two cell types to esterify 9-*cis*-retinol was also confirmed by *in vitro* enzyme assays. The activities of the two main retinyl esterifying enzymes, LRAT (lecithin:retinol acyltransferase) and ARAT (acyl-coA: retinol acyltransferase), were observed in both cell types. Moreover, both cell types were able to hydrolyze 9-*cis*-retinyl esters to 9-*cis*-retinol *in vitro*. Taken together these data suggest that liver cells can take up 9-*cis*-retinol from media and also metabolize it while maintaining the stereochemical integrity of 9-*cis*-retinoids.

9-*cis*-retinoids are found in kidney and liver of various species (6-9) albeit at a low levels. We analyzed the liver of three month-old male mice that were maintained on a normal chow diet and found that total 9-*cis*-retinol (9-*cis*-retinol + 9-*cis*-retinyl esters) were present at 0.25% of the level of total all-*trans*-isomers. However, the source of this 9-*cis*-retinoid remains unknown. 9-*cis*-carotene has been suggested as a dietary source of 9-*cis*-retinol (6,10-12). However, the efficiency of the conversion of 9-*cis*- β -carotene to 9-*cis*-retinol is controversial (11,13). Since all-*trans*-retinol can be isomerized to 9-*cis*-retinol *in vitro*, we investigated the possibility that all-*trans*-retinol is a precursor for 9-*cis*-retinol, and subsequently 9-*cis*-retinoic acid. While most of all-*trans*-retinol present in cells is bound to cellular retinol binding protein (CRBP), approximately 30 nM exists as unbound-retinol in liver (14). Thus, we incubated whole cell homogenates of Hep G2 cells with 30 nM [³H]all-*trans*-retinol and measured the formation of 9-*cis*-retinal. Cell homogenates were found to convert all-*trans*-retinol first to 9-*cis*-retinol and subsequently to 9-*cis*-retinal, thus suggesting that these cells can use all-*trans*-retinol not bound to CRBP as a precursor for 9-*cis*-retinol formation.

Even though Hep G2 cells endogenously express cRDH, as assessed by semi-quantitative RT-PCR analysis, the expression levels were too low to be used for studying the biochemical characteristics of the enzyme. Thus, we over-expressed cRDH into Hep G2 cells, using retroviruses containing the full-length cRDH cDNA. These cell lines are referred to as **LRDHSN/Hep G2**. Using homogenates from **LRDHSN/Hep G2** cells, we determined that cRDH is indeed a 9-*cis*-retinol oxidizing enzyme and that the enzyme

follows Michaelis-Menten kinetics. Furthermore, we found that high concentrations of 9-*cis*-retinol can inhibit the synthesis of 9-*cis*-retinoic acid by interfering with the oxidation of 9-*cis*-retinal by enzymes present in Hep G2 cells. This result may help explain why the tissue levels of 9-*cis*-retinol is low, since high level of 9-*cis*-retinol would result in diminished levels of 9-*cis*-retinoic acid synthesis.

These studies provided a context from which to understand our subsequent studies of cRDH actions in human mammary carcinoma cells.

2. The role of cRDH in 9-*cis*-retinol metabolism and cell growth in breast cancer cells

9-*Cis*-retinoic acid has been shown to be effective in inhibiting cultured breast cancer cell growth and in delaying mammary tumor growth in animal models (2-4). We note that cRDH-transduced Hep G2 cells did not exhibit a diminution of cell proliferative capacity. Since we established that cRDH is involved in 9-*cis*-retinol oxidation and thus, in 9-*cis*-retinoic acid synthesis we hypothesized that cRDH over-expression would result in growth inhibition of breast cancer cells by increasing the 9-*cis*-retinoic acid synthesized by these cells. To test this hypothesis we created **LRDHSN/MCF7** cells, a human mammary carcinoma cell line, that expresses high levels of cRDH by employing retroviruses containing the full-length cRDH cDNA (the same retroviral construct used to generate **LRDHSN/Hep G2** cells). This cell line was used to test the role and actions of cRDH in 9-*cis*-retinol metabolism and on MCF7 cell proliferation. We are currently finalizing a manuscript describing our findings from these studies that will be soon be submitted for publication. This manuscript is attached as an appendix to this report. Please refer to the detailed descriptions of the methods and results in this appended material. Only a brief overview of these studies will be provided below.

Aim 1. Determine the cell specificity and expression levels of the novel cRDH by *in situ* hybridization and RT-PCR

RNA from two normal human mammary epithelial cell strains (HMECs) [AG11132 and AG11134] and a panel of breast cancer cell lines [MCF7, T47D, MDA-MB-231, and Hs578T] were examined for cRDH expression using semi-quantitative RT-PCR. Poly (A⁺) RNA was extracted from cultured cells using a mRNA isolation kit (Roche Molecular Biochemicals) according to the manufacturer's instructions. Reverse transcription (RT) was performed utilizing 300 ng of mRNA from each cell line or strain using Superscript RT® (Gibco) and random hexamers (Roche Molecular Biochemicals) at 42° C for 1hr. An aliquot of each RT reaction (1 µl) was subsequently used for PCR. A semi-quantitative PCR strategy adapted from Henegariu *et al* (15) was applied to measure relative mRNA levels. Primers for cRDH and for hypoxanthine-phosphoribosyltransferase (HPRT) were used in a same reaction tube to amplify both genes simultaneously. The HPRT primers were 1676-1696 (5'-CCGCGCGCTGGCCGGATCCGTT-3') and 41481-41502 (5'-GTTTCCAAACTCAACTTGAATTCTCATC-3') relative to the genomic sequence (16), resulting in a 705 bp-product. The cRDH primers were 587-605 (5'-GATCAACATCACCAGCGTC-3') and 851-870 (5'-TGATGCGCTGTTGCATTTTC-3') of the cDNA sequence (5), resulting in a 283 bp-product. PCR conditions were in a total reaction volume of 25 µl with 4.8 pmole of each cRDH primer, 1 pmole of each HPRT primer, 3 mM MgCl₂, 1.5 U Taq-polymerase (Roche Molecular Biochemicals), 40 mM tetramethylammonium chloride (Sigma). Thermal cycling parameters were 94° C for 5 min, (94° C for 1 min, 58° C for 1 min, 72° C for 1 min) x 30, 32, or 35 cycles. The resulting products (15 µl) were loaded onto a 1.5% agarose gel and transferred to a membrane (Zeta-probe membrane, BioRad) following depurination and denaturation according to manufacturer's recommendation. ³²P-labeled oligomer probes were prepared from nested sequences (HPRT, 40073-40092; RDH, 668-689) by an end labeling method using T4 polynucleotide kinase (Roche Molecular Biochemicals). Hybridization was performed in 5x SSC, 1x Denhardt's, 2 µg/ml salmon sperm DNA, 1% SDS, 25 mM NaH₂PO₄, pH 6.5

with $\sim 2 \times 10^5$ cpm/ml of each oligomer probe at 55° C. The final wash was 5x SSC/0.1% SDS at 55° C for 25 min. Evaluation of the signal intensities was performed using a Cyclone Phosphor Scanner® (Packard Instrument) and relative intensities of cRDH and HPRT were calculated.

A representative result from six independent experiments is shown below in **Figure 1**. In general, tumor cell lines showed higher cRDH expression as compared to normal HMECs. However, when enzyme activity levels were tested by *in vitro* cRDH enzyme assays, we could not detect significant differences among cell lines (data not shown). Thus, it appears that mRNA expression levels of cRDH do not parallel functional protein levels. Higher levels of mRNA may also be a reflection of aneuploidy in tumor cell lines, and RT-PCR may have exaggerated this difference due to its exponential increase of copy number. cRDH has been mapped to chromosome 12 (17), and trisomy 12 has been reported in breast cancer cases (18-20). Moreover, the two sets of primers for HPRT and cRDH may compete for limited amount of common elements in the PCR reaction, such as dNTPs and Taq-polymerase, and thus, accentuate the differences among cell lines.

Figure 1. mRNA expression of cRDH in various breast cancer cells and normal HMECs.

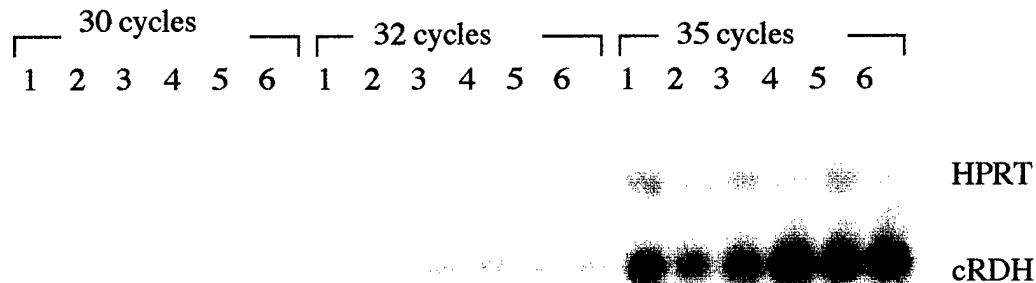

1. AG11132; 2. AG11134; 3. MCF7; 4. T47D; 5. MDA-MB-231; 6. Hs578T

In summary, the expression levels of cRDH mRNA was low in both breast cancer cells and normal HMECs, as the expression could be detected only by RT-PCR but not by Northern blot analysis. Even though the cRDH expression levels of mRNA and protein were varied among cancer cells and normal HMECs, the differences among them did not seem to be significant.

The second part of this aim, *in situ* hybridization studies to localize the cRDH expression in cultured cells and primary breast tissues was not carried out beyond development of digoxigenin labeling of a probe. Because of the low levels of cRDH in the normal and breast cancer cells, we felt that we would be unable to reproducibly detect cRDH expression in mammary tissue. Instead, a more thorough study to characterize the cRDH properties and to delineate the 9-*cis*-retinoic acid synthesis pathways were conducted (see Section 1. Biochemical characterization of cRDH and 9-*cis*-retinoic acid synthesis pathway).

Aim 2. Determine growth response and metabolic profiles of breast cells to retinol

a. Growth response

To assess the role of cRDH in 9-*cis*-retinol metabolism and in regulating breast cancer cell growth, MCF7 cells were stably transduced with cRDH (*LRDHSN/MCF7*) and both mass-culture and clonal cell lines were established. As a control, empty vector (*LXSN*) transduced cell lines were also created. MCF7 cells were chosen since they express the lowest levels of endogenous cRDH by RT-PCR (see Aim 1). In addition, MCF7 cells were reported to be growth inhibited by 9-*cis*-retinoic acid treatment (21-23). Thus, we hypothesized that the proliferative inhibition of MCF7 cells could be used as an indicator of 9-*cis*-retinoic acid synthesis upon cRDH over-expression and 9-*cis*-retinol treatment.

As we hypothesized, 1 μ M 9-*cis*-retinol treatment over a 7 d-period produced a decline in cumulative cell numbers of **LRDHSN/MCF7** cells as compared to control treatment (vehicle alone). An average of 60-80% growth suppression of **LRDHSN/MCF7** cells was observed from repeated experiments. Since growth repression was observed only in cRDH transduced cells but not in empty vector transduced cells, this suggested that the growth inhibition is likely arises from 9-*cis*-retinol metabolite(s). Moreover, the same concentration of all-*trans*-retinol treatment did not exert the same degree of growth inhibition of either **LRDHSN/MCF7** or **LXSN/MCF7** cells. Thus, we concluded that both cRDH and 9-*cis*-retinol are required for the proliferative inhibition of MCF7 cells.

b. Metabolic profiles

Next, we wanted to determine whether the observed growth inhibition resulted from the synthesis and/or accumulation of 9-*cis*-retinoic acid in **LRDHSN/MCF7** cells treated with 9-*cis*-retinol. Cells and media were collected during the 7 d-period from cultures used for growth kinetic studies, and the types and concentrations of 9-*cis*-retinoids in these fractions were measured by HPLC. 9-*Cis*-retinal formation was observed for both cells and media of cRDH transduced MCF7 cells, while no detectable levels of 9-*cis*-retinal were observed in those of **LXSN/MCF7** cells (empty vector transduced cell lines). These results suggest that cRDH indeed oxidizes 9-*cis*-retinol in the cultured cells. However, 9-*cis*-retinoic acid, the oxidation product of 9-*cis*-retinal was not detected in either cells or media of either **LRDHSN/MCF7** or **LXSN/MCF7** cells. Because we could not detect 9-*cis*-retinoic acid, we were concerned that we missed a window of opportunity when 9-*cis*-retinoic acid formation occurs. The first time points tested was 24 hours after the treatment with 9-*cis*-retinol. To rule out the possibility of rapid synthesis and metabolism of 9-*cis*-retinoic acid in **LRDHSN/MCF7** cells, we conducted short-term metabolism studies such that cells and media were harvested at a various time point up to 24 h. The earliest time point for this experiment was 30 min after the 9-*cis*-retinol treatment. Again, 9-*cis*-retinal formation was found in only **LRDHSN/MCF7** cells and media, but still no detectable 9-*cis*-retinoic acid was observed in either cells or media.

Since rapid synthesis and metabolism of 9-*cis*-retinoic acid upon the treatment with 9-*cis*-retinol in MCF7 cells did not seem to occur, we hypothesized that MCF7 cells might lack the ability to convert 9-*cis*-retinal to 9-*cis*-retinoic acid. This possibility was examined by *in vitro* enzyme assays where 9-*cis*-retinal was incubated with whole cell homogenates of either MCF7 or Hep G2 cells for 30 min, and 9-*cis*-retinoic acid production was detected by HPLC. Compared to the positive control, Hep G2 cells, MCF7 cells produced negligible amounts of 9-*cis*-retinoic acid, suggesting absence of 9-*cis*-retinal oxidizing enzyme expression and/or activity.

While analyzing 9-*cis*-retinoid profiles in transduced MCF7 cells treated with 9-*cis*-retinol, we discovered that the rate of disappearance of 9-*cis*-retinol from the culture media was far in excess of the amount of 9-*cis*-retinal that we found in media and cells. This raised the possibility that these cells metabolize 9-*cis*-retinol to retinoids other than 9-*cis*-retinoic acids, possibly to retinyl esters and/or retinyl-glucuronides. Thus, we investigated this hypothesis utilizing 9-*cis*-[³H]retinol labeled at the non-exchangeable C₂₀ position. Both **LXSN/MCF7** and **LRDHSN/MCF7** cells were cultured in media containing the radiolabeled 9-*cis*-retinol and the radiolabeled 9-*cis*-retinol metabolites were followed by in-line radioactivity monitor with HPLC. Glucuronidation and esterification were not found to occur at any significant levels. However, we detected an unidentified radiolabeled metabolite of 9-*cis*-retinol that was extracted with retinol and retinal. This unknown compound eluted before 13-*cis*-retinol on our HPLC method and shows maximum absorption at about 290 nm. Currently, we are investigating the identity and anti cell proliferative actions of this possibly novel metabolite.

Despite the lack of 9-*cis*-retinoic acid synthesis and accumulation, cRDH transduced MCF7 cells were growth inhibited upon 1 μ M 9-*cis*-retinol treatment. Thus it appears that metabolites of 9-*cis*-retinol, other than 9-*cis*-retinoic acid are responsible for

this effect. One obvious candidate for causing this growth arrest seemed to be 9-*cis*-retinal, which was observed only in **LRDHSN/MCF7** cells upon treatment with 9-*cis*-retinol but not in **LXSN/MCF7** cells. Thus, we cultured both of the transduced cell lines in media containing 1 μ M 9-*cis*-retinol over a 7 d-period and analyzed cell proliferation kinetics by cell counts using a hemocytometer. As expected, both cell types were growth inhibited by the 9-*cis*-retinal treatment, suggesting that 9-*cis*-retinal might be at least partly responsible for the growth inhibition observed in **LRDHSN/MCF7** cells treated with 9-*cis*-retinol. However, the degree of proliferative inhibition upon treatment with 9-*cis*-retinal was lower than that upon 9-*cis*-retinol treatment. This finding may imply that other metabolites such as the unknown compound, in addition to 9-*cis*-retinal exert the growth suppressing activity. Once we identify the structure of the unknown compound, we are planning to examine its effect on breast cancer cell proliferation.

Interestingly, when we analyzed cells and media of transduced MCF7 cell lines upon the treatment with 9-*cis*-retinal, we found that only **LXSN/MCF7** cells and media contained significant levels of 9-*cis*-retinol. Since our studies of **LRDHSN/Hep G2** cells indicate that cRDH catalyzes 9-*cis*-retinol oxidation to near completion, this finding supports the notion that the physiologic function of cRDH is oxidation of 9-*cis*-retinol. Moreover, this finding also suggests that MCF7 cells may contain enzymes that are capable of reducing 9-*cis*-retinal that are distinct from cRDH.

Aim 3. Determine cRDH expression in comparison to retinoid profiles in biopsy samples of breast tissue from randomly sampled women

This aim was not completed since the characterization of enzyme and delineation of 9-*cis*-retinoic acid synthesis in Hep G2 cells required significant time, and I completed my degree requirements. Moreover, due to the finding of insignificant differences as well as the exceedingly low levels of mRNA expression assessed by RT-PCR in cultured normal and tumor cells (above), we suggest that levels of mRNA in human tissues will likely be difficult to interpret. In the future we would like to analyze protein levels in normal and tumor specimens if a suitable antibody is available for immunocytochemical analyses.

In summary, we found that cRDH is involved in 9-*cis*-retinol oxidation in cultured cells. The presence of the enzyme and the substrate, 9-*cis*-retinol, resulted in suppression of breast cancer cell growth. Further studies exploring the role of cRDH in various breast cancer cell lines, both estrogen receptor positive and negative, are well warranted. I believe that cRDH may play a critical role in maintaining normal cell proliferation in mammary tissue.

KEY RESEARCH ACCOMPLISHMENTS

1. Development of **LRDHSN/Hep G2** cells, a human hepatoma cell line that over-expresses cRDH
2. Characterization of cRDH and 9-*cis*-retinol metabolism using the liver cell culture model, **LRDHSN/Hep G2** cells:
 - a. cRDH oxidizes 9-*cis*-retinol to 9-*cis*-retinal.
 - b. cRDH follows Michaelis-Menten kinetics for 9-*cis*- and 11-*cis*-retinol oxidation.
 - c. High concentrations of 9-*cis*-retinol are inhibitory to 9-*cis*-retinal oxidation in Hep G2 cells, thus hindering synthesis of 9-*cis*-retinoic acid.
3. Development of a breast cancer cell line, **LRDHSN/MCF7** cells, that over-expresses cRDH. This has proven to be a useful model for examining 9-*cis*-retinol metabolism in cultured cells.
4. Characterization of the effect of cRDH and 9-*cis*-retinol on breast cancer cell growth kinetics using **LRDHSN/MCF7** cells:
 - a. Both transduction of cRDH and treatment with 9-*cis*-retinol are required for growth suppression of MCF7 cells.
 - b. Growth inhibition of **LRDHSN/MCF7** cells is likely due to metabolites of 9-*cis*-retinol, including 9-*cis*-retinal.
5. Identification of the metabolic pathways of 9-*cis*-retinol utilization by transduced MCF7 cells:
 - a. cRDH oxidizes 9-*cis*-retinol to 9-*cis*-retinal in cultured MCF7 cells.
 - b. 9-*cis*-retinal production was detected only in **LRDHSN/MCF7** cells but not in **LXSN/MCF7** cells upon the treatment with 9-*cis*-retinol.
 - c. 9-*cis*-retinoic acid synthesis did not occur, due to a lack of an enzyme that oxidizes 9-*cis*-retinal to 9-*cis*-retinoic acid in MCF7 cells.
 - d. 9-*cis*-retinal appeared to be metabolized to an unknown compound that can be extracted with the same method used for retinol/retinal.
 - e. The unknown compound is likely a metabolite of 9-*cis*-retinal since it is observed in only **LRDHSN/MCF7** cells treated with 9-*cis*-retinol but not in **LXSN/MCF7**. Furthermore, the compound can be found in both cell types when the media was supplemented with 9-*cis*-retinal.
 - f. Glucuronidation and esterification of 9-*cis*-retinol are not major metabolic pathways in either **LXSN/MCF7** or **LRDHSN/MCF7** cells.

CHANGES MADE FROM THE ORIGINAL STATEMENT OF WORK

1. Biochemical characterization of the enzyme and the delineation of 9-*cis*-retinoic acid synthesis pathway was included and performed in human hepatoma Hep G2 cells. Hep G2 cells were chosen for this study since liver is one of the major sites where vitamin A is stored and metabolized in the body, and most of the factors that are involved in vitamin A metabolism are present in liver cells.
2. Instead of using a transient transfection method for our studies, stable transduction of cRDH was performed to create a breast cancer cell line that over-express cRDH.
Stable transduction has several advantages over transient transfection
 - Constant supply of relatively homogeneous populations of transduced cells: no variation of transfection efficiency.
 - Single copy number of the transduced gene per cell.
 - Once virus containing the gene of interest is produced, we will be able to infect other human cell lines thus, we can broaden our research scope to examine the effect of cRDH on other breast cancer cell lines (ER⁺ and ER⁻).
3. Effect of 13-*cis*-retinol on growth kinetics has been modified due to:
 - The significance of the 13-*cis*-retinoids in physiology is not known at this point.
 - Instead, we tested all-*trans*-retinol to examine whether the growth inhibition of **LRDHSN/MCF7** cells observed during 9-*cis*-retinol treatment was specific to this

isomer. This is more informative for understanding the specificity of 9-*cis*-retinol actions on breast cancer cell growth.

4. Proposed growth kinetics studies on two different breast cancer cell lines, MCF7 and MDA231 were modified so as to allow for the investigation of cRDH effect on MCF7 cells more thoroughly. This decision was based partly on the observation that
 - RT-PCR study showed that MCF7 cells and MDA231 cells contained similar levels of cRDH. Thus, we concerned that we may not be able to detect subtle differences in growth kinetics of the two cell lines by 9-*cis*-retinol.
 - Consequently, we created a control cell line which was transduced with empty vector to compare the effect of cRDH and 9-*cis*-retinol on breast cancer cell proliferation.
 - Moreover, L~~X~~S~~N~~/MCF7 and L~~R~~D~~H~~S~~N~~/MCF7 are likely a better model system, since we assume that the genetic background of the two cell lines are similar and thus we may attribute any differences between two cell lines after the treatment with 9-*cis*-retinol to the role of cRDH.
5. RT-PCR studies of cRDH expression in primary breast tissue from benign and malignant could not be conducted due to the time limit imposed by my Ph.D. program. We instead, conducted extensive studies on characterization of the enzyme, cRDH, and 9-*cis*-retinoic acid synthesis pathway using Hep G2 cells. My degree was awarded before the proposed time frame (6 month earlier).

REPORTABLE OUTCOMES

Manuscripts

1. *9-cis*-retinoids: Biosynthesis of *9-cis*-retinoic acid. Jisun Paik, Silke Vogel, Roseann Piantedosi, Angela Sykes, William S. Blaner, and Karen Swisshelm. Biochemistry 39: 8073-8084, 2000
2. *Cis*-retinol dehydrogenase: *9-cis*-retinol metabolism and its effect on growth of human MCF7 breast cancer cells. Jisun Paik, William S. Blaner, and Karen Swisshelm. In preparation

Abstracts

1. Characterization of *9-cis*-retinol dehydrogenase. Mary Gamble, Jisun Paik, James R. Mertz, E. Shang, Karen Swisshelm, Debora J. Wolgemuth, and William S. Blaner. Presented at the 1997 European Retinoid Research Group Meeting, Nice France
2. Expression and activity of a *9-cis*-retinol dehydrogenase in normal human mammary epithelial cells and breast cancer cells. Jisun Paik, William S. Blaner, and Karen Swisshelm. Presented at the 1998 FASEB Summer Research Conference on Retinoids, Snowmass Co.
3. The role of *cis*-retinol dehydrogenase in *9-cis*-retinol metabolism in a breast cancer cell line, MCF7. Jisun Paik, William S. Blaner, and Karen Swisshelm. Presented at the 2000 Era of Hope Meeting. Atlanta, GA
4. The role in *9-cis*-retinol metabolism and the effect on cell growth in two model systems. Jisun Paik, William S. Blaner, and Karen Swisshelm. Presented at the 2000 FASEB Summer Research Conference on Retinoids, Copper Mt., Co.

Degree obtained

Doctor of Philosophy from University of Washington, Nutritional Science Program, March 17th, 2000

Dissertation Title: *Cis*-retinol dehydrogenase: Characterization and biochemical analysis of *9-cis*-retinol metabolism in two model systems.

Development of cell lines

LRDHSN/Hep G2: human hepatoma cell lines that are stably transduced with human cRDH

LXSN/Hep G2: control, empty-vector transduced cell lines

LRDHSN/MCF7: human breast cancer cell lines that are stably transduced with human cRDH

LXSN/MCF7: control, empty vector transduced cell lines

Employment

Postdoctoral research scientist at Columbia University in Dr. William Blaner's lab in the Department of Medicine

Possible patent/ licensing:

A submission has been sent to the Office of Technology Transfer at the University of Washington for review of possible patentability and market potential.

CONCLUSIONS

We have shown that cRDH plays a role in 9-*cis*-retinol metabolism *in vitro* and in cultured cells, and thus, may participate in synthesis of 9-*cis*-retinoic acid, the physiologic ligand for RXRs. The low levels of total 9-*cis*-retinol found in tissues may be explained considering that high concentrations of 9-*cis*-retinol can be inhibitory to 9-*cis*-retinoic acid synthesis.

We have also shown that cRDH and 9-*cis*-retinol play a critical role in inhibition of cell growth of human breast cancer cell line, MCF7. Furthermore, this growth inhibition did not require synthesis and/or accumulation of 9-*cis*-retinoic acid, suggesting that there are other retinoid metabolites than retinoic acid, that can exert growth inhibitory effect on breast cancer cells. This finding may be applicable in the future as a two-pronged breast cancer treatment; a targeted gene therapy with cRDH in combination with chemotherapy using low dose of 9-*cis*-retinol.

REFERENCES

1. Sporn, M. B., Roberts, A. B., and Goodman, D. S. (1994) *The Retinoids: Biology, Chemistry, and Medicine*, 2nd Ed., Raven Press, New York
2. Gottardis, M. M., Lamph, W. W., Shalinsky, D. R., Wellstein, A., and Heyman, R. A. (1996) *Breast Cancer Res Treat* 38, 85-96
3. Moon, R. C., Mehta, R. G., and Detrisac, C. H. (1992) *Cancer Detect. Prev.* 16, 73-79
4. Moon, R. C., Mehta, R. G., and Rao, K. V. N. (1994) in *The Retinoid : Biology, Chemistry, and Medicine* (Sporn, M. B., Roberts, A. B., and Goodman, D. S., eds), 2nd Ed., pp. 573-595, Raven Press, New York
5. Mertz, J. R., Shang, E., Piantedosi, R., Wei, S., Wolgemuth, D. J., and Blaner, W. S. (1997) *J Biol Chem* 272, 11744-9
6. Ben-Amotz, A., Mokady, S., and Avron, M. (1988) *Br J Nutr* 59, 443-9
7. Labrecque, J., Dumas, F., Lacroix, A., and Bhat, P. V. (1995) *Biochem J* 305, 681-4
8. Matssui, M., Okano, S., Yamasha, K., Miyano, M., Kitamura, S., Kobayash, A., Sato, T., and Mikami, R. (1958) *J Vitaminol* 4, 178-189
9. Brown, P. S., Blum, W. P., and Stern, M. H. (1959) *Nature* 184, 1377-1379
10. Levin, G., and Mokady, S. (1994) *Int J Vitam Nutr Res* 64, 165-9
11. Hebuterne, X., Wang, X. D., Johnson, E. J., Krinsky, N. I., and Russell, R. M. (1995) *J Lipid Res* 36, 1264-73
12. Ben-Amotz, A., Mokady, S., Edelstein, S., and Avron, M. (1989) *J Nutr* 119, 1013-9
13. You, C. S., Parker, R. S., Goodman, K. J., Swanson, J. E., and Corso, T. N. (1996) *Am J Clin Nutr* 64, 177-83
14. Posch, K. C., Boerman, M. H., Burns, R. D., and Napoli, J. L. (1991) *Biochemistry* 30, 6224-30
15. Henegariu, O., Heerema, N. A., Dlouhy, S. R., Vance, G. H., and Vogt, P. H. (1997) *Biotechniques* 23, 504-11
16. Jolly, D. J., Okayama, H., Berg, P., Esty, A. C., Filpula, D., Bohlen, P., Johnson, G. G., Shively, J. E., Hunkapillar, T., and Friedmann, T. (1983) *Proc Natl Acad Sci U S A* 80, 477-81
17. Simon, A., Lagercrantz, J., Bajalica-Lagercrantz, S., and Eriksson, U. (1996) *Genomics* 36, 424-30
18. Adeyinka, A., Pandis, N., Bardi, G., Bonaldi, L., Mertens, F., Mitelman, F., and Heim, S. (1997) *Cancer Genet Cytogenet* 97, 119-21
19. Engel, H., Kleespies, C., Friedrich, J., Breidenbach, M., Kallenborn, A., Schondorf, T., Kolhagen, H., and Mallmann, P. (1999) *Br J Cancer* 81, 1165-73
20. Mark, H. F., Brown, S., Taylor, W., Bassily, N., Sun, C. L., Samy, M., and Bland, K. I. (1999) *Cancer Genet Cytogenet* 108, 26-31
21. Van heusden, J., Wouters, W., Ramaekers, F. C., Krekels, M. D., Dillen, L., Borgers, M., and Smets, G. (1998) *Br J Cancer* 77, 26-32
22. Rubin, M., Fenig, E., Rosenauer, A., Menendez-Botet, C., Achkar, C., Bentel, J. M., Yahalom, J., Mendelsohn, J., and Miller, W. H., Jr. (1994) *Cancer Res* 54, 6549-56
23. Zhao, Z., Zhang, Z. P., Soprano, D. R., and Soprano, K. J. (1995) *Exp Cell Res* 219, 555-61

9-*cis*-Retinoids: Biosynthesis of 9-*cis*-Retinoic Acid[†]Jisun Paik,[‡] Silke Vogel,[§] Roseann Piantedosi,[§] Angela Sykes,^{||} William S. Blaner,^{§,||} and Karen Swisshelm^{*,‡,⊥}*Nutritional Sciences Program and Department of Pathology, University of Washington, Seattle, Washington 98195, and Department of Medicine and Institute of Human Nutrition, Columbia University, New York, New York 10032**Received September 17, 1999; Revised Manuscript Received March 21, 2000*

ABSTRACT: Retinoids function through conformational alterations of ligand-dependent nuclear transcription factors, the retinoic acid receptors, and retinoid X receptors. 9-*cis*-Retinoic acid is a known biological ligand for retinoid X receptors, but its synthesis pathway *in vivo* is largely unknown. Recently, we identified a *cis*-retinol dehydrogenase (cRDH) that oxidizes 9-*cis*-retinol to 9-*cis*-retinal. Since both the expression of cRDH mRNA and its substrate are found in liver, we studied 9-*cis*-retinol metabolism and 9-*cis*-retinoic acid biosynthesis in two hepatic-derived cell types, Hep G2 hepatoma cells and HSC-T6 stellate cells. Both cell lines accumulate similar amounts of 9-*cis*-retinol provided in the medium. However, Hep G2 cells preferentially incorporate *all-trans*-retinol when equimolar concentrations of *all-trans*- and 9-*cis*-retinol were provided. In contrast, HSC-T6 cells did not exhibit a preference between *all-trans*- and 9-*cis*-retinol under the same conditions. Esterification of 9-*cis*-retinol occurred in both cell types, likely by acyl-CoA:retinol acyltransferase and lecithin:retinol acyltransferase. *In vitro* enzyme assays demonstrated that both cell types can hydrolyze 9-*cis*-retinyl esters via retinyl ester hydrolase(s). In Hep G2 cells, 9-*cis*-retinoic acid synthesis was strongly inhibited by high concentrations of 9-*cis*-retinol, which may explain the low levels of 9-*cis*-retinol in liver of mice. Cell homogenates of Hep G2 can convert *all-trans*-retinol to 9-*cis*-retinal, suggesting that the free form of *all-trans*-retinol may be used as a source for 9-*cis*-retinol and, thus, 9-*cis*-retinoic acid synthesis. Our studies provide the basis for identification of additional pathways for the generation of 9-*cis*-retinoic acid in specialized tissues.

Retinoids play an essential role in vertebrate growth and development, supporting cell differentiation (1–3); embryonic development (4, 5), vision (6), the immune response (7), and reproduction (8). The actions of retinoids are mediated through binding and activation of the retinoic acid receptors (RARs)¹ or retinoid X receptors (RXRs), which function as ligand-dependent transcription factors. It is generally accepted that *all-trans*-retinoic acid serves as a physiologic ligand for the RARs and that 9-*cis*-retinoic acid acts as the preferred ligand for the RXRs (9, 10).

Although the biochemical processes responsible for *all-trans*-retinoic acid formation from its precursor, *all-trans*-

retinol, are beginning to be elucidated, there is still little information available regarding how 9-*cis*-retinoic acid is formed within cells and tissues (11, 12). Three possible pathways for 9-*cis*-retinoic acid formation have been proposed. These consist of (1) the isomerization of *all-trans*-retinoic acid to 9-*cis*-retinoic acid, probably through non-enzymatic processes (13); (2) enzymatic oxidation of 9-*cis*-retinol to 9-*cis*-retinoic acid through a pathway similar to the oxidation of *all-trans*-retinol to *all-trans*-retinoic acid (14–19), and (3) the cleavage of 9-*cis*- β -carotene yielding directly 9-*cis*-retinoic acid or 9-*cis*-retinol/9-*cis*-retinal that is subsequently oxidized to 9-*cis*-retinoic acid (20, 21). Although each of these pathways is possible, and the *in vitro* data supporting each of them are individually convincing, it is still unclear from the literature to what extent which of these pathways occur *in vivo*.

We have previously reported and characterized an enzyme that we originally termed 9-*cis*-retinol dehydrogenase (16). Because of the broad substrate specificity for *cis*-retinols and relative inability to catalyze *all-trans*-retinol oxidation (22), we now refer to this enzyme as *cis*-retinol dehydrogenase (cRDH). By Northern blot, the enzyme is expressed in liver, kidney, testis, and several other tissues in the human and mouse (16, 22–24). On the basis of these and other data, we suggested that cRDH might be an important component of a biosynthetic pathway resulting in the formation of 9-*cis*-retinoic acid. In the present report, we provide further characterization of the biochemical properties of this enzyme relevant to 9-*cis*-retinoic acid formation and investigate the metabolism of 9-*cis*-retinoids by hepatic cells.

[†] This work was supported by a U.S. Army Predoctoral Award DAMD17-97-1-7252 to J.P., a pilot and feasibility award through the University of Washington Clinical Nutrition Research Unit (NIH Grant DK35816) and the Seattle Foundation to K.S., and NIH Grant DK52444 to W.S.B.

* To whom correspondence should be addressed at the Department of Pathology, Box 357470, 1959 N.E. Pacific St., D-511 HSB, University of Washington, Seattle, WA 98195-7470. Phone 206-616-3182; fax 206-543-3644; e-mail kswiss@u.washington.edu.

[‡] Nutritional Sciences Program, University of Washington.

[§] Department of Medicine, Columbia University.

^{||} Institute of Human Nutrition, Columbia University.

[⊥] Department of Pathology, University of Washington.

¹ Abbreviations: RAR, retinoic acid receptor; RXR, retinoid X receptor; cRDH, *cis*-retinol dehydrogenase; PGK, phosphoglycerate kinase; DTT, dithiothreitol; PVDF, poly(vinylidene difluoride); ECL, enhanced chemiluminescence; HPLC, high-performance liquid chromatography; FBS, fetal bovine serum; LRAT, lecithin:retinol acyltransferase; ARAT, acyl-CoA:retinol acyltransferase; REH, retinyl ester hydrolase; BSA, bovine serum albumin; 11cRDH, 11-*cis*-retinol dehydrogenase; ROL, retinol; RAL, retinal.

EXPERIMENTAL PROCEDURES

Retinoids. *all-trans*-Retinal, 13-*cis*-retinal, 9-*cis*-retinal, *all-trans*-retinol, and 13-*cis*-retinol were purchased from Sigma. 11-*cis*-Retinal was a gift of Dr. Christian Eckhoff of Hoffmann-LaRoche, Inc. The internal standard, used to assess retinol and retinal recovery, was *all-trans*-9-(4-methoxy-2,3,6-trimethylphenyl)-3,7-dimethyl-2,4,6,8-nonatetraen-1-ol (TMMP-ROH, Ro12-0586) (25), obtained from Dr. Louise H. Foley (Hoffmann-LaRoche, Inc). 9-*cis*-Retinol and 11-*cis*-retinol were prepared by reducing 9-*cis*-retinal and 11-*cis*-retinal, respectively, with NaBH₄ (Sigma) followed by purification by normal-phase high-performance liquid chromatography (HPLC) (16).

Cell Culture. LXS/N/Hep G2 and LRDHSN/Hep G2 cells were cultured in α -modified Eagle's medium (α -MEM) supplemented with 10% fetal bovine serum (FBS). The HSC-T6 cells were cultured in Waymouth's medium supplemented with 10% FBS. All cells were cultured at 37 °C in 5% CO₂.

Endogenous Expression of cRDH by RT-PCR. RNA was extracted from parental Hep G2 cells and transduced Hep G2 cells (LXS/N/Hep G2 and LRDHSN/Hep G2) by guanidine isothiocyanate/cesium chloride centrifugation following standard procedures (26). RNA from human liver was obtained from Dr. Ken Thummel (Department of Pharmaceutics, University of Washington). Reverse transcription (RT) was performed with 2 μ g of total RNA with Superscript RT (Gibco) and random hexamers (Roche Molecular Biochemicals) at 42 °C for 1 h. The RT reaction (1 μ L) was subsequently used for the PCR reaction. The cRDH primers were 587–605 (5'-GATCAACATCACCAGCGTC-3') and 851–870 (5'-TGATGCGCTGTTGCATTTTC-3') of the cDNA sequence (16), resulting in a 283 bp product. PCR conditions were in a total reaction volume of 25 μ L with 4.8 pmol of each cRDH primer, 3 mM MgCl₂, 1.5 units of Taq polymerase (Roche Molecular Biochemicals), and 40 mM tetramethylammonium chloride (Sigma). Thermal cycling parameters were 94 °C for 5 min, (94 °C for 1 min, 58 °C for 1 min, and 72 °C for 1 min) \times 35 cycles, and 72 °C for 5 min. For a control, a housekeeping gene, phosphoglycerate kinase (PGK), was also amplified with primers reported by Sasaki et al. (27). The PCR conditions and thermal cycling conditions were the same as described above except for the annealing temperature of 55 °C. The resulting products for both the cRDH and PGK reactions (15 μ L) were loaded onto a 1.5% agarose gel, separated by electrophoresis, and stained with ethidium bromide. The reverse image of UV-illuminated gel was obtained by the Stratagene Eagle-eye system, and densitometry was performed with NIH Image (version 1.60). Relative cRDH expression was determined by the ratio of cRDH (AU)/PGK (AU).

Transduction of Hep G2 Cells with cRDH. The full-length cRDH cDNA, including a polyadenylation signal, was directionally cloned from pcDNA3 (16) into the *Eco*RI and *Xho*I sites within the multiple cloning site of pLXS/N (28) (Figure 1). Two packaging cell lines, PE501 and PA317, were used to generate viruses capable of infecting human cell lines following the method of Miller et al. (29). Viruses produced by PA317 cells with high titer and intact gene structure were used to infect Hep G2 cells, a human hepatocyte-derived cell line (30). The resulting cell lines are referred to as LXS/N/Hep G2 (empty vector) and LRDHSN/

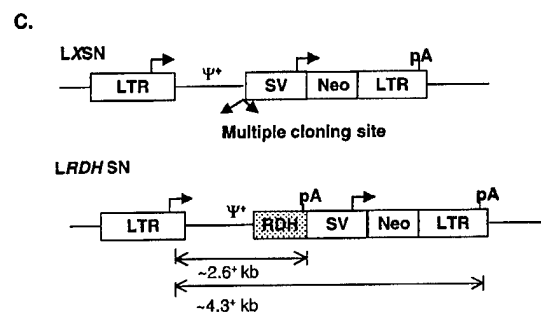
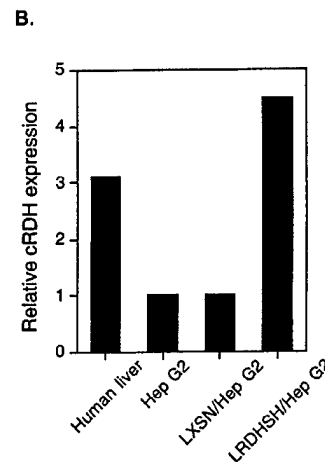
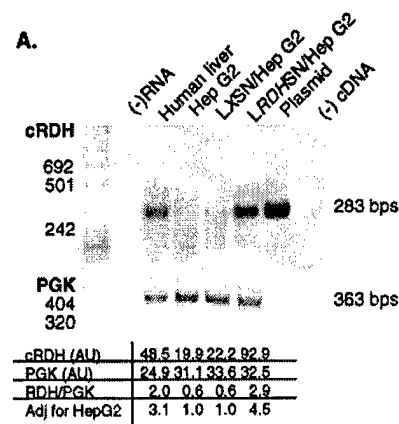

FIGURE 1: Expression of cRDH mRNA in human liver- and hepatocyte-derived cells and retroviral vector structures. (A) Total RNA (2 μ g) of human liver, parental, and transduced Hep G2 cells was used for reverse transcription (RT) followed by PCR. cRDH primers were 587–605 (F) and 851–870 (R) of the cDNA sequence (upper gel). For a comparison, a housekeeping gene, PGK, was also amplified (lower gel) as described under Experimental Procedures. Negative controls were used for both RT (–mRNA) and PCR (–cDNA) reactions. A full-length cRDH plasmid was used as a positive control. Amplicons (15 μ L each) were analyzed on 1.5% ethidium bromide-stained agarose gels. The reverse image of the UV-illuminated gel as detected by the Stratagene Eagle-eye system was analyzed by NIH image and expressed as arbitrary units (below the images). (B) Relative expression levels of cRDH were calculated by cRDH (AU)/PGK (AU), adjusted by the value of Hep G2 cells (arbitrarily = 1), and presented as a histogram. (C) Full-length cRDH cDNA, including its polyadenylation signal sequence, was cloned into LXS/N. LTR, long terminal repeat; SV, simian virus 40 promoter; Neo, neomycin phosphotransferase; pA, polyadenylation signal. The expected sizes for mRNA transcripts of cRDH directed by the retrovirus are \sim 2.6 and 4.5 kb.

Hep G2. To ensure the success of the gene transduction, mRNA and protein expression were examined by Northern blot and Western blot analysis. The enzyme activity of the expressed protein was tested *in vitro* employing the assay procedure described below.

Northern Blot Analysis. RNA was extracted by guanidine isothiocyanate/cesium chloride centrifugation following standard procedures (26) from LXS/N/Hep G2 and LRDHSN/Hep G2 cells, and 20 μg of total RNA was loaded onto 1.2% denaturing agarose gel and blotted onto a membrane (Zeta-probe membrane, Bio-Rad). A ^{32}P -labeled (α -dCTP) probe was prepared from the full-length cRDH cDNA by use of a Random prime labeling kit (Roche Molecular Biochemicals) according to the manufacturer's instructions. Hybridization was carried out overnight at 42 °C. The final wash was 2 \times SSC/0.1% SDS at 65 °C and the blot was exposed to X-ray film for autoradiography.

Western Blot Analysis. Microsomes of transduced Hep G2 cells were prepared by the method of Fleischer and Kervina (31) with some modification. Briefly, cells were grown to confluency on P 150 mm² tissue culture plates, harvested in a buffer containing 25 mM Tris, pH 7.4, 0.25 M sucrose, and 1 mM dithiothreitol (DTT), and homogenized with a Dounce homogenizer (B pestle) 50 times on ice followed by centrifugation at 12000g for 10 min at 4 °C. This process was repeated and supernatants were pooled and centrifuged at 100000g for 1 h at 4 °C. The resulting crude microsomal pellet was resuspended in 25 mM Tris, pH 7.4, and 1 mM DTT. Aliquots were snap-frozen in an ethanol-dry ice bath and stored at -70 °C. Protein concentration was determined by the Bradford assay (Bio-Rad) per the manufacturer's recommendation.

Crude microsomes (50 μg of protein) obtained from each cell line were loaded onto an SDS-15% polyacrylamide gel and, following electrophoresis, transferred onto a poly(vinylidene difluoride) (PVDF) membrane (Bio-Rad) at 30 V overnight at 4 °C. Following incubation in 2% milk blocking solution for 1 h, the membrane was incubated with a rabbit-derived anti-polypeptide antibody (22) (1:5000 dilution) for 1 h at room temperature. After being washed with PBS containing 0.1% Tween 20, the membrane was incubated with a secondary goat anti-rabbit antibody conjugated to horseradish peroxidase (1:2000 dilution, Santa Cruz) for 1 h at room temperature. The membrane was washed again as described above, and the signal was detected by enhanced chemiluminescent (ECL) reagent (Pierce) according to the manufacturer's instructions. Molecular weight standards were from Santa Cruz (sc-2035).

Enzyme Assays. Enzyme activity was measured by a modification of the method described by Mertz et al. (16). In a total reaction volume of 600 μL , total cell homogenates (100 μg of protein) of LRDHSN/Hep G2 or LXS/N/Hep G2 were incubated at 37 °C for 1 h with 10 μM 9-*cis*-retinol (in ethanol) in the presence of 2 mM NAD⁺ in a buffer containing 10 mM HEPES, pH 8.0, 150 mM KCl, and 2 mM EDTA (assay buffer). The total volume of ethanol used to dissolve 9-*cis*-retinol did not exceed 5% of the total reaction volume. Assays were carried out under the red light to minimize photoisomerization of retinoids. At the start of each assay, the reaction tubes were briefly flushed with N₂ before being sealed with Parafilm and covered with aluminum foil. These steps were taken to minimize contact with

O₂ and light during incubation. At the end of the incubation, an equal volume of 100% ethanol (600 μL) was added to each reaction to denature the proteins and to stop the reaction. Retinol and retinal isomers were then extracted in 2.5 mL of hexane and analyzed by normal-phase HPLC as described below.

Retinoid Metabolism by Hepatocytes and Hepatic Stellate Cells. Both LXS/N/Hep G2 human hepatoma cells and HSC-T6 rat hepatic stellate cells were employed to study the metabolism of 9-*cis*-retinoids by intact cells.

HSC-T6 stellate cells were isolated from male retired-breeder Sprague-Dawley rats as previously described (32) and maintained in primary culture on plastic culture dishes for 15 days in the presence of 10% fetal calf serum (FCS). On day 15 of culture, the stellate cells were transiently transfected with an expression plasmid containing the large T-antigen of SV40, and clones were isolated. One clone, designated HSC-T6, was expanded for further characterization. The use and characteristics of this cell line have been published (33). HSC-T6 stellate cells exhibit an activated phenotype as reflected in their fibroblastlike shape and rapid proliferation in culture. Also, the cells express cytoskeletal proteins including desmin, α smooth muscle actin, glial acidic fibrillary protein, and vimentin that are typical of activated stellate cells. Among the most striking features of hepatic stellate cells *in vivo* are the numerous vitamin A-rich lipid droplets that are present within the cytoplasm. When cultured in medium containing physiologic concentrations of retinol (2 mM), HSC-T6 stellate cells develop lipid droplets (34).

For studies of retinoid metabolism, medium was removed in the morning of the experiment and replaced with medium supplemented with different concentrations of either 9-*cis*-retinol, *all-trans*-retinol, or the combination. After predetermined times, ranging up to 5 h, the cells and medium were collected for extractions and HPLC analysis of retinyl ester, retinol, retinal, and/or retinoic acid isomer concentrations. For these measurements, cell pellets were homogenized in either 0.5 or 1.0 mL of PBS with a Polytron homogenizer (Brinkmann Instruments), and proteins were denatured through addition of an equal volume (0.5 or 1.0 mL) of 100% ethanol to the homogenate. Cell homogenates or medium was extracted with 2.5 mL of hexane, and the extracts were analyzed for retinol/retinal or retinyl ester concentrations by normal-phase HPLC. For retinoic acid measurements, cell homogenates and medium were extracted with 6 mL of chloroform/methanol (2:1 v/v) and the lower retinoid-containing chloroform phase was collected for normal-phase HPLC analysis carried out as described below.

Retinoid Analyses of Mouse Tissues. Concentrations of 9-*cis*-retinol and 9-*cis*-retinyl esters were measured in mouse serum and liver. For this purpose, 3-month-old male C57Bl/6J mice were exposed to CO₂, blood was collected by cardiac puncture, and the liver was dissected in a dark room under a red photographic light. The dissected livers were immediately frozen in liquid N₂ and stored for up to 1 week at -70 °C prior to HPLC analysis. Livers were homogenized using a Polytron homogenizer in 3 volumes of ice-cold PBS (25% w/v homogenate). To determine retinol concentrations, an aliquot of the homogenate was denatured with an equal volume of 100% ethanol and extracted twice into 5 mL of hexane. The two hexane extracts were combined and

evaporated to dryness under a gentle stream of N₂ followed by analysis by normal-phase HPLC for *all-trans*- and *9-cis*-retinol as described below.

To assess *all-trans*- and *9-cis*-retinyl esters, total *all-trans*- and *9-cis*-retinol concentrations were determined after saponification of retinoids. The differences obtained from the measurement of total retinol and unesterified retinol were taken as retinyl esters. For total retinol measurements, an aliquot of the liver homogenate was extracted in 6 volumes of chloroform/methanol (2:1 v/v). The lower retinoid-containing chloroform phase was removed and evaporated to dryness under a gentle stream of N₂. The lipids were then redissolved in 2 mL of 50% (w/v) KOH in ethanol and allowed to incubate for 2 h at 65 °C. After the incubation, 2 mL of PBS was added and the saponified retinoids were extracted into 5 mL of hexane. The hexane extract was backwashed 5 times with 2 mL of PBS and evaporated to dryness under N₂. Concentrations of total *all-trans*- and *9-cis*-retinol were determined by normal-phase HPLC.

HPLC Analysis. Retinol and retinal isomers were separated on a 4.6 × 150 mm Supelcosil LC-Si column (Supelco Inc.) preceded by a silica guard column (Supelco Inc.) with hexane/ethyl acetate/butanol (96.9:3:0.1 v/v/v) as the mobile phase and a flow rate of 0.8 mL/min. Isomers of retinol and retinal were detected by absorbance at 325 and 365 nm, respectively, on a Waters 996 Photodiode array detector (Waters 600E multisolvent delivery system, 717⁺ auto-sampler, and Millennium³² software). Retinol and retinal peaks were identified by comparing retention times and spectra of experimental compounds to those of authentic standards. Each retinol and retinal isomer was quantitated by comparing its integrated area under the peak against those of known amounts of purified standards. The loss during extraction was accounted for by adjusting the recovery to that of the internal standard.

Retinyl ester concentrations were measured by normal-phase HPLC on the same silica columns described above but with hexane/diethyl ether (99.9:0.1 v/v) as the mobile phase at a flow rate of 0.8 mL/min (35). Retinoic acid isomer levels for cells and medium were also assessed by normal-phase HPLC employing two tandem silica columns (a 3.9 × 150 mm Resolve Silica column, Waters and a 4.6 × 150 mm Supelcosil LC-Si column, Supelco Inc.) and hexane/acetonitrile/acetic acid (99.5:0.4:0.1 v/v/v) as the running solvent (1.8 mL/min flow rate) (36).

Enzymatic Assays for Retinol Esterification and Retinyl Ester Hydrolase Activities. We employed standard assays to assess hepatic lecithin:retinol acyltransferase (LRAT), acyl-CoA:retinol acyltransferase (ARAT), and retinyl ester hydrolase (REH) activities (37–39). The enzymatic assays for ARAT and LRAT were carried out as described by Ross (38) and Randolph and Ross (37), respectively. Briefly, for the ARAT assay, cells were homogenized in 0.15 M potassium phosphate buffer, pH 7.4, with a Dounce homogenizer. The homogenate was centrifuged at 40 000 rpm in a Beckman TC-100 ultracentrifuge for 60 min at 4 °C to obtain a crude microsomal fraction. The crude microsomes were resuspended in 0.15 M potassium phosphate buffer, pH 7.4. To distinguish between retinyl esters formed during the *in vitro* assay and retinyl esters endogenous to the crude microsomal fraction, we used *n*-heptadecanoyl-coenzyme A as the fatty acyl-CoA. Retinyl esters containing this fatty

acyl group are not endogenously present in cells. For the assay (total volume 0.5 mL), 500 μg of microsomal protein was incubated for 1 h at 37 °C with 100 μM *n*-heptadecyl-CoA, 120 μM *all-trans*- or *9-cis*-retinol in 50 mM potassium phosphate buffer, pH 7.2, containing 5 mM DTT and 20 μM bovine serum albumin (BSA). For the LRAT assay, cells were homogenized in 150 mM potassium phosphate buffer, pH 7.25, and crude microsomes were obtained as described above. The microsomal protein (250 μg) was incubated with 5 μM of either *all-trans*- or *9-cis*-retinol in a buffer containing 20 μM BSA and 5 mM DTT for 1 h at 37 °C. The enzymatic reaction was stopped with an equal volume of ice-cold ethanol and the retinoids were extracted in either 2 volumes of hexane (for ARAT) or 2.5 mL of hexane (for LRAT) and analyzed by normal-phase HPLC (see above). A control lacking either retinol isomer was included for both the ARAT and LRAT assays. In preliminary experiments prior to carrying out measures of LRAT and ARAT specific activities in microsomes prepared from HSC-T6, LXS/N/Hep G2, and LRDHSN/Hep G2 cells, we established for both LRAT and ARAT, employing our assay conditions, that rates of retinyl ester formation were linear with respect to both time of incubation and microsomal protein concentration. Moreover, by varying the assay concentrations of retinol (both the *all-trans*- and *9-cis*-isomers) for these trials, we established that the rate of product formation (retinyl ester) was independent of substrate concentration (i.e., was at substrate saturation).

Retinyl ester hydrolase (REH) assays were carried out on unfractionated homogenates prepared in 10 mM Tris-HCl, pH 8.0, with a Dounce homogenizer. Assays were carried out in 50 mM Tris-maleate buffer, pH 8.0, in the presence and absence of 1% (w/v) sodium taurocholate as described by Friedman et al. (39). The substrates for these assays consisted of either 10 μM *all-trans*-retinyl oleate or 10 μM *9-cis*-retinyl oleate that had been synthesized through reaction of an individual retinol isomer with oleyl chloride in the presence of pyridine catalyst (40). Reaction mixtures (0.2 mL) were incubated for 1 h at 37 °C followed by addition of an equal volume of ice-cold ethanol to terminate the reaction. Extraction and analysis of retinoids were done as described above.

Determination of the Equilibrium Constant of Human cRDH. The equilibrium constant of cRDH at 37 °C and under our standard assay conditions was determined for *9-cis*-retinal formation. For this purpose, we employed an approach previously used to calculate the equilibrium constant of bovine rod outer segment *all-trans*-retinol dehydrogenase (41). Briefly, the assay we routinely used to measure *9-cis*-retinal formation was allowed to go to completion (2 h incubation). From the final concentrations of *9-cis*-retinol and *9-cis*-retinal measured by HPLC, the known initial concentrations of substrates, and the final pH, it is possible to calculate an equilibrium constant for the reaction. That a state of equilibrium had been established was verified through demonstration that addition of fresh cRDH had no effect on the final *9-cis*-retinol and *9-cis*-retinal concentrations. Addition of fresh substrate (*9-cis*-retinol and NAD⁺) to the equilibrium mixture restarted the reaction, indicating the presence of active cRDH at equilibrium.

Production of *9-cis*-Retinal. In some experiments, we explored the contribution of cRDH to the synthesis of *9-cis*-

retinoic acid via oxidation of 9-*cis*-retinol to 9-*cis*-retinal. For these experiments, 1 μCi of *all-trans*-[^3H]retinol was incubated with either *LRDHSN*/Hep G2 or *LXSN*/Hep G2 cell homogenate (100 μg) or assay buffer alone in the presence of 2 mM NAD^+ . The final reaction volume was 0.6 mL and the final concentration of *all-trans*-retinol was 0.03 μM . Immediately following incubation, 0.6 mL of ice-cold ethanol was added to the incubation mixture and retinoids were extracted into 2.5 mL of hexane. The presence of 9-*cis*-retinol and 9-*cis*-retinal in the reaction mixture was assessed by normal-phase HPLC as described above.

cRDH Enzyme Kinetics. Microsomes of *LRDHSN*/Hep G2 cells (50 μg) were incubated at 37 $^{\circ}\text{C}$ for 5 min with either 9-*cis*-retinol or 11-*cis*-retinol (in 100% ethanol) at various concentrations (0, 1, 2, 3, 4, 5, 7.5, 10, or 15 μM) in the assay buffer containing 2 mM NAD^+ . Delipidated BSA (60 μM) (Sigma) was added to each reaction to ensure reproducible kinetics (14). Extraction and analysis of retinol and retinal were performed as described above.

RESULTS

Expression of cRDH in Hep G2 Cells. We wished to study the possible actions of cRDH in catalyzing the first oxidation step needed for the formation of 9-*cis*-retinoic acid from 9-*cis*-retinol. We previously employed cRDH expressed in CHO cells as a source of recombinant cRDH to study the biochemical properties of the enzyme (16). However, CHO cells lack endogenous expression (unpublished observation) and may not be a relevant physiologic context to study cRDH activity. We were interested in studying cRDH in a cellular environment where it would normally be present. Consequently, we expressed cRDH in Hep G2 cells. As seen in Figure 1A, RT-PCR analysis indicates that cRDH mRNA is expressed endogenously, albeit at low level, in Hep G2 cells. cRDH mRNA expression levels in parental Hep G2 cells as well as *LXSN*/Hep G2 cells were lower than that of a human liver tissue, approximately $\frac{1}{3}$ the expression level. The expression levels of cRDH in cRDH-transduced Hep G2 cells were similar to that of human liver. Potential amplification of genomic DNA was ruled out by using primers that span an intron of about 1.9 kb (42). No genomic DNA band (~ 2.2 kb) was detected.

Transduction of Hep G2 Cells with cRDH. Since the level of endogenous cRDH activity present in Hep G2 cells is very low (Figure 2C), and we wanted to characterize some of the biochemical properties of this enzyme in a cellular environment, we overexpressed cRDH in Hep G2 cells. This was accomplished by transducing Hep G2 cells with a retroviral vector containing the full-length cRDH cDNA, *LRDHSN* (Figure 1B). As a negative control, empty vector- (*LXSN*-) transduced Hep G2 cells were also created. To examine the success of the gene transduction, expression of mRNA and protein and enzyme activity of cRDH were analyzed by Northern blot analysis (Figure 2A), Western blot analysis (Figure 2B), and in vitro enzyme assay (Figure 2C), respectively.

Upon hybridization of Northern blot with ^{32}P -labeled full-length cRDH probe, the expected transcript sizes of 2.6 and 4.5 kb, resulting from two known polyadenylation sites (Figure 1B), were detected only in *LRDHSN*/Hep G2 cells (Figure 2A). No endogenous 1.4 kb cRDH transcript could

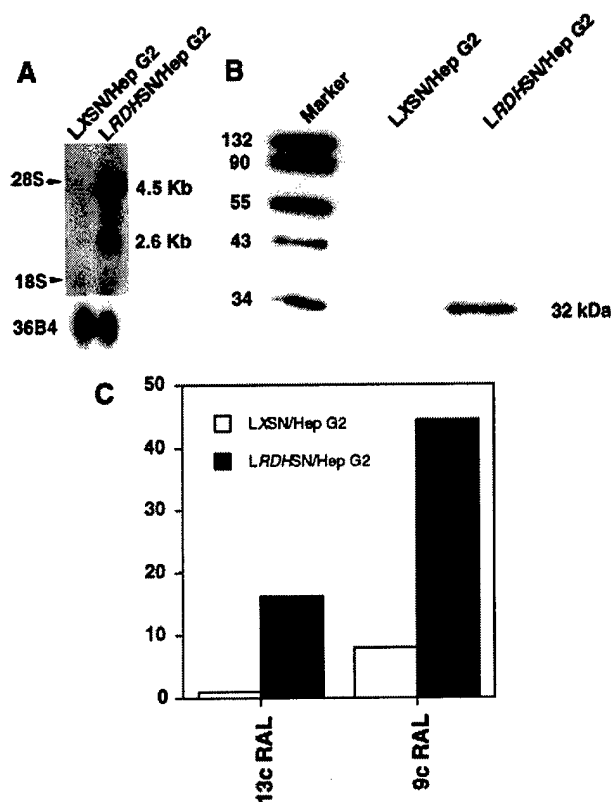

FIGURE 2: Expression and activity of cRDH in transduced Hep G2 cells. (A) Northern blot analysis of total RNA shows the expected size of mRNA transcripts (4.5 and 2.6 kb) from *LRDHSN*/Hep G2 (B) Immunoblot analysis of microsomes of transduced Hep G2 cells. An expected ~ 32 kDa protein was detected only from microsomes of *LRDHSN*/Hep G2 cells. (C) Whole-cell homogenates (100 μg) of *LXSN*/Hep G2 and *LRDHSN*/Hep G2 were analyzed for cRDH activity. *LRDHSN*/Hep G2 cells produced approximately 6 times more 9-*cis*-retinal compared to *LXSN*/Hep G2 cells. Detection of 13-*cis*-retinal was attributed to the isomerization from 9-*cis*-retinal.

be detected in the *LRDHSN*/Hep G2 cells or the *LXSN*/Hep G2 cells.

To confirm expression of cRDH protein, an immunoblotting assay was performed with a polyclonal antipeptide antibody (22). As expected, we detected an approximate 32 kDa protein band in microsomal fractions obtained from *LRDHSN*/Hep G2 cells but not in microsomes from *LXSN*/Hep G2 cells (Figure 2B). cRDH protein was not detected from cytosolic fractions of either cell lines (data not shown). Multiple Western blot analyses of microsomal protein from *LXSN*/Hep G2 cells did show a faint immunoreactive band that migrated at approximately 32 kDa, indicating that a low, endogenous level of cRDH protein is present in Hep G2 cells (data not shown). This is consistent with RT-PCR analysis showing expression of endogenous cRDH mRNA in non-transduced Hep G2 cells (Figure 1A).

To ascertain whether the cRDH protein expressed in Hep G2 cells was catalytically functional, an in vitro enzyme activity assay was performed. Whole-cell homogenates (100 μg of protein) of *LXSN*/Hep G2 or *LRDHSN*/Hep G2 were incubated with 10 μM 9-*cis*-retinol and 2 mM NAD^+ at 37 $^{\circ}\text{C}$. Following a 60 min incubation period, retinoids were extracted and subjected to HPLC analysis. *LRDHSN*/Hep G2 cells possessed approximately 6-fold more cRDH-specific

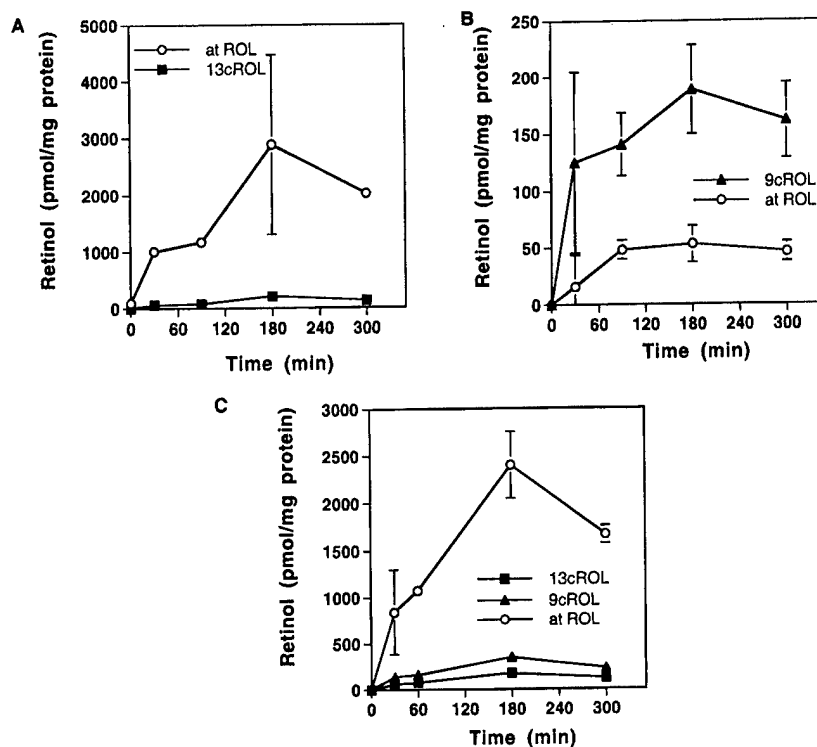

FIGURE 3: Retinol uptake by HSC-T6 cells. HSC-T6 cells were grown in the medium supplemented with either (A) *all-trans*-retinol (2.5 μ M), (B) *9-cis*-retinol (2.5 μ M), or (C) the combination (2.5 μ M each) over 5 h. Retinol levels associated with HSC-T6 cells were analyzed by HPLC at predetermined time points. Each data point represents a mean from triplicate plates. Note the scale differences in y axis among graphs.

activity than the LXSN/Hep G2 cells [1.55 vs 0.27 nmol h^{-1} (mg of protein) $^{-1}$] (Figure 2C).

Metabolism of 9-cis-Retinol by Human Hep G2 Hepatocytes and Rat Liver HSC-T6 Stellate Cells. Little is known about the presence and metabolism of *9-cis*-retinoids within cells and tissues. It has been established that *9-cis*-retinol is present, albeit at relatively low levels, in rat liver (20) and rat kidney (15), but as far as we are aware there has been no systematic study focusing on the metabolism of *9-cis*-retinoids within these or other tissues. It is presently not known whether cells can take up *9-cis*-retinol and maintain the stereochemical integrity of this retinol isomer. Moreover, there is limited information available regarding whether *9-cis*-retinol can be esterified in cells to *9-cis*-retinyl esters or whether *9-cis*-retinyl esters can be hydrolyzed by cellular hydrolases to *9-cis*-retinol. Our studies were designed to explore these possibilities. Since the substrate, *9-cis*-retinol, and the enzymes that are capable of oxidizing *9-cis*-retinol (16, 18, 19) are present in the liver, we chose to carry out our studies in liver cells, Hep G2 human hepatoma cell line, and HSC-T6, rat liver stellate cells (also called fat-storing cells, Ito cells, or lipocytes).

To study its intracellular metabolism, both Hep G2 and HSC-T6 cells were loaded with *9-cis*-retinol. For cell loading, *9-cis*-retinol was added to the tissue culture medium. Since we did not know whether the hepatic-derived cells have the ability to remove *9-cis*-retinol from medium and maintain the *cis* configuration, a parallel study was carried out with *all-trans*-retinol. Intracellular levels of both *all-trans*- and *9-cis*-retinol increased with time and retinol concentration in the two hepatic cell types. The time dependence of *all-trans*-retinol and *9-cis*-retinol accumulation in HSC-T6 cells

is shown in Figure 3, panels A and B, respectively. The cellular level of *all-trans*-retinol in HSC-T6 cells is approximately 20-fold greater than that of *9-cis*-retinol. Relatively little of the *all-trans*-retinol associated with the HSC-T6 cells was isomerized to *9-cis*-retinol during the experimental period. Approximately 25% of the *9-cis*-retinol accumulated in HSC-T6 cells underwent isomerization to *all-trans*-retinol, but over the 5 h duration of this experiment, the relative amount of *9-cis*-retinol associated with the HSC-T6 cells did not appreciably change with time (approximately 75% of the total retinol associated with the HSC-T6 cells remained in the *9-cis* configuration throughout the experiment). This implies that the *9-cis* configuration of retinol is stable within hepatic cells. Interestingly, as can be seen in Figure 3C, when equimolar concentrations of *all-trans*-retinol (2.5 μ M) and *9-cis*-retinol (2.5 μ M) were provided together in the medium of HSC-T6 cells, the levels of *all-trans*- and *9-cis*-retinol detected in the cells were not different from those observed when each retinol isomer was added individually to the culture medium.

LXSN/Hep G2 cells accumulate less *all-trans*-retinol from the culture medium compared to HSC-T6 cells (Figure 4A). After 5 h of incubation, *all-trans*-retinol concentrations in Hep G2 cells reached approximately 500 pmol/mg of protein (compared to 2000 pmol/mg of protein in HSC-T6 cells). The level of *9-cis*-retinol detected in Hep G2 cells was very similar to that observed for HSC-T6 cells (Figure 4B) (160 vs 180 pmol/mg of protein, respectively). As was the case for HSC-T6 cells, approximately 25% of the total retinol associated with the Hep G2 cells exposed to *9-cis*-retinol was present as *all-trans*-retinol (Figure 4B). However, unlike HSC-T6 cells, when equimolar concentrations of both *all-*

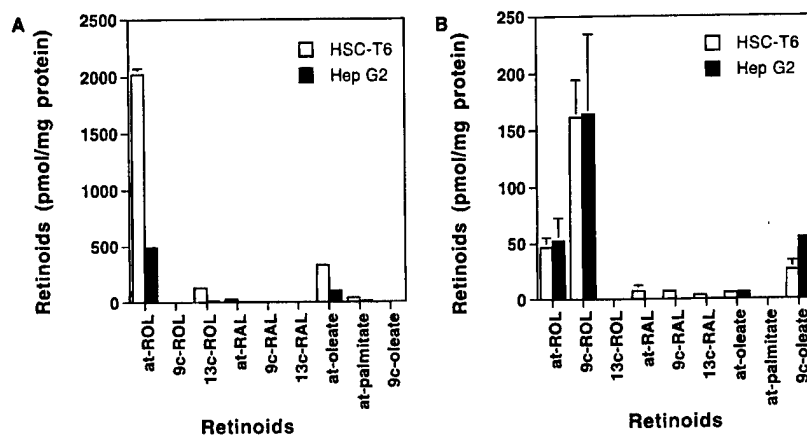

FIGURE 4: Retinoid metabolites by HSC-T6 and LXSN/Hep G2 cells. HSC-T6 and LXSN/Hep G2 cells were cultured in the medium containing (A) *all-trans*-retinol (2.5 μ M) or (B) 9-*cis*-retinol (2.5 μ M) for 5 h. Retinoids associated with cells were analyzed by HPLC. Results are from triplicate plates.

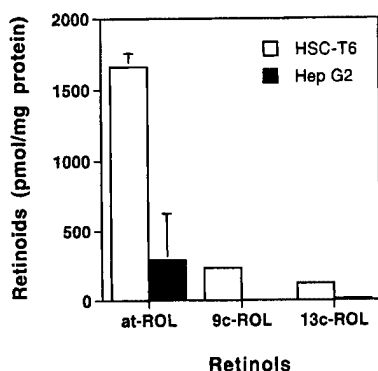

FIGURE 5: Retinol profiles in HSC-T6 and LXSN/Hep G2 treated with the combination of *all-trans*-retinol and 9-*cis*-retinol. HSC-T6 and LXSN/Hep G2 cells were cultured in medium containing both *all-trans*-retinol (2.5 μ M) and 9-*cis*-retinol (2.5 μ M) for 5 h. Concentrations of retinol isomers in cells were measured by HPLC analysis. Results represent the mean data from triplicate plates.

trans- and 9-*cis*-retinol were added to the LXSN/Hep G2 culture medium, only *all-trans*-retinol was found to be associated with the LXSN/Hep G2 cells (Figure 5).

Over the 5 h time period, both *all-trans*- and 9-*cis*-retinol were observed to undergo significant metabolism to retinal and retinyl esters within the HSC-T6 and LXSN/Hep G2 cells. The distributions of retinol, retinal, and retinyl ester metabolites associated with HSC-T6 cells and LXSN/Hep G2 cells following a 5 h incubation with medium supplemented with either *all-trans*-retinol (2.5 μ M) or 9-*cis*-retinol (2.5 μ M) are given respectively in Figure 4 panels A and B. Significant amounts of 9-*cis*-retinyl esters were formed upon addition of 9-*cis*-retinol to either LXSN/Hep G2 or HSC-T6 cells. Thus, not only can 9-*cis*-retinol accumulate within cells without loss of its geometric configuration but also it can be processed by the cells to 9-*cis*-retinyl ester, a putative storage form for this retinol isomer.

Since both hepatocyte- and stellate-derived cells were found to esterify 9-*cis*-retinol to 9-*cis*-retinyl esters, we measured *in vitro* the levels of retinol esterifying activities (for both *all-trans*- and 9-*cis*-isomers) associated with Hep G2 and HSC-T6 cells. Since two microsomal enzymes, ARAT and LRAT, have been proposed to participate in retinol esterification in liver cells (37, 38, 43), the specific activities of both LRAT and ARAT were measured in crude

microsomes prepared from Hep G2 and HSC-T6 cells by standard assay procedures for the two enzymatic activities (37, 38). In preliminary studies carried out prior to these assays, we established that our assay conditions gave rates of product formation that were linear with respect to both time and microsomal protein concentration. In addition, we established in these preliminary experiments that the substrate (*all-trans*- and 9-*cis*-retinol) concentrations that we employed in the assays were saturating (giving rise to zero-order kinetics). Both LRAT and ARAT activities were observed to be present in the HSC-T6, LXSN/Hep G2, and LRDHSN/Hep G2 cells. *all-trans*-Retinol proved to be a better substrate for both the LRAT and ARAT activities present in each of these different cell lines. For the HSC-T6 cells, the LRAT activities directed against *all-trans*- and 9-*cis*-retinol were, respectively, 4.58 ± 0.30 and 0.42 ± 0.06 nmol of retinol consumed h^{-1} (mg of protein) $^{-1}$ (mean ± 1 standard deviation), whereas, for the HSC-T6 cells, the mean ARAT activities directed against *all-trans*- and 9-*cis*-retinol were, respectively, 1.69 ± 0.29 and 0.12 ± 0.03 nmol of retinol consumed h^{-1} (mg of protein) $^{-1}$. As we expected, we observed no significant differences for the specific activities that we determined for LRAT and ARAT between the LXSN/Hep G2 and LRDHSN/Hep G2 cell lines. Thus, a high level of expression of cRDH in the Hep G2 cells does not influence the levels of esterifying activities within the cells. For the LXSN/Hep G2 and LRDHSN/Hep G2 lines, mean LRAT specific activities toward the *all-trans*- and 9-*cis*-isomers of retinol averaged, respectively, 2.50 ± 0.34 and 1.72 ± 0.18 nmol of retinol consumed h^{-1} (mg of protein) $^{-1}$ (for LXSN/Hep G2 cells) and 2.61 ± 0.03 and 1.76 ± 0.05 nmol of retinol consumed h^{-1} (mg of protein) $^{-1}$ (for LRDHSN/Hep G2 cells). The microsomal hepatocyte ARAT activity showed a marked preference for the *all-trans*-retinol isomer over the 9-*cis*-isomer. For LXSN/Hep G2 and LRDHSN/Hep G2 cells, mean ARAT specific activities toward *all-trans*- and 9-*cis*-retinol were determined to be respectively, 1.83 ± 0.16 and 0.13 ± 0.01 nmol of retinol consumed h^{-1} (mg of protein) $^{-1}$ (for LXSN/Hep G2 cells) and 1.61 ± 0.02 and 0.13 ± 0.01 nmol of retinol consumed h^{-1} (mg of protein) $^{-1}$ (for LRDHSN/Hep G2 cells).

We similarly asked whether HSC-T6 and Hep G2 cells are capable of the enzymatic hydrolysis of *all-trans*- and

9-*cis*-retinyl esters. Since both bile salt-dependent and bile salt-independent retinyl ester hydrolases may play roles in the hydrolysis of hepatic retinyl esters (43), we carried out hydrolase assays in the presence and absence of 1% (w/v) sodium cholate. We were able to measure both bile salt-independent and bile salt-dependent retinyl ester hydrolase activities for microsomes prepared from HSC-T6, LXSN/Hep G2, and LRDHSN/Hep G2 cells for both *all-trans*- and 9-*cis*-retinyl oleate. Interestingly, the specific activities of the bile salt-dependent retinyl ester hydrolase directed against *all-trans*- and 9-*cis*-retinyl esters were not statistically different for the three cell lines. Thus, it would appear that the bile salt-dependent retinyl ester hydrolase activity present in each of these cell lines does not show a strong substrate preference for one isomeric configuration over another. The bile salt-independent retinyl ester hydrolase activities for the HSC-T6, LXSN/Hep G2, and LRDHSN/Hep G2 each showed a slight substrate preference for *all-trans*-retinyl oleate over the 9-*cis*-isomer. On the basis of these *in vitro* measures, we conclude that HSC-T6 stellate cells and Hep G2 hepatocytes possess the enzymatic machinery needed to hydrolyze both *all-trans*- and 9-*cis*-retinyl esters. This observation is consistent with our earlier observation that each of these cultured hepatic cell lines is able to take up and process both *all-trans*- and 9-*cis*-retinol.

Endogenous Level of Retinoids in Tissue. Data obtained from the study of cultured liver cells suggest that the liver has the capacity for accumulating and metabolizing 9-*cis*-retinol. However, there is limited information regarding 9-*cis*-retinol and/or 9-*cis*-retinyl ester levels in tissues of living organisms. To address this, we investigated the levels of 9-*cis*-retinol and 9-*cis*-retinyl ester present in serum and liver of 3-month-old fasting male mice. We could not detect 9-*cis*-retinol or 9-*cis*-retinyl ester in mouse serum. The lower limit of detection for these HPLC-based assays was less than 3 nM for 9-*cis*-retinol and 9-*cis*-retinyl esters. Thus, it would appear that neither 9-*cis*-retinol nor 9-*cis*-retinyl esters are present in the blood of fasted mice or are present at low levels. However, 9-*cis*-retinol and 9-*cis*-retinyl esters were detected in all livers obtained from these mice. As reported previously, the mean concentration of 9-*cis*-retinol measured from six livers was $0.42 \pm 0.18 \mu\text{g/g}$ of liver and that of *all-trans*-retinol for the same livers was $28.5 \pm 3.5 \mu\text{g/g}$ of liver (22). Here we report that the total 9-*cis*-retinol concentration (9-*cis*-retinol + 9-*cis*-retinyl esters) for these six livers was $2.31 \pm 0.77 \mu\text{g/g}$ of liver and that of total *all-trans*-retinol (*all-trans*-retinol + *all-trans*-retinyl esters) was $898.5 \pm 141.2 \mu\text{g/g}$ of liver. It is clear from these data that some endogenous 9-*cis*-retinol and 9-*cis*-retinyl ester is present in normal mouse liver, albeit at levels that are only approximately 0.25% of those of the *all-trans* isomers.

9-*cis*-Retinoic Acid Synthesis by LRDHSN/Hep G2 Cell Homogenates. In our studies of 9-*cis*-retinol metabolism, we observed some 9-*cis*-retinoic acid formation in Hep G2 cells. Since it is generally thought that the first step in retinoic acid biosynthesis (i.e., retinol oxidation) is rate-limiting, we wanted to assess whether changes in levels of cRDH activity in the Hep G2 cells would influence cellular 9-*cis*-retinoic acid levels. To test this, total cell homogenates from LXSN/Hep G2 and LRDHSN/Hep G2 were incubated with $10 \mu\text{M}$ 9-*cis*-retinol for 1 h and the amount of 9-*cis*-retinoic acid formed was measured by HPLC. Surprisingly, the amount

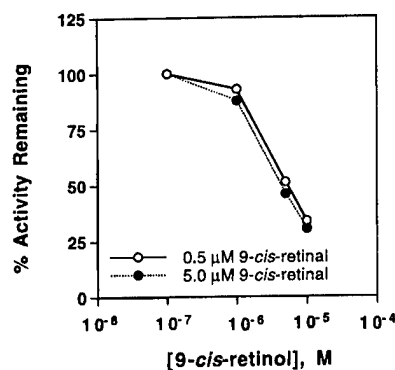

FIGURE 6: 9-*cis*-Retinol is a potent inhibitor of 9-*cis*-retinol oxidation. Whole-cell homogenates ($100 \mu\text{g}$) of LXSN/Hep G2 were incubated for 20 min with various concentrations of 9-*cis*-retinol in the presence of two fixed concentrations ($0.5 \mu\text{M}$ or $5 \mu\text{M}$) of 9-*cis*-retinol. 9-*cis*-Retinol oxidation was inhibited by 50% with $5 \mu\text{M}$ 9-*cis*-retinol. Each data point is a mean of duplicate reactions.

of cRDH-specific activity present in the homogenates did not influence the amount of 9-*cis*-retinoic acid generated from 9-*cis*-retinol (data not shown). We then examined Hep G2 cells for the capacity to oxidize 9-*cis*-retinol when different concentrations of 9-*cis*-retinol were incubated with LRDHSN/Hep G2 cell homogenates. For this experiment the amount of 9-*cis*-retinoic acid formed was found to be dependent on time and 9-*cis*-retinol concentration (data not shown). Thus, Hep G2 cells are able to form 9-*cis*-retinoic acid from 9-*cis*-retinol. Previously, Bhat and colleagues (15) reported that 9-*cis*-retinol can act as a potent *in vitro* inhibitor of the rat kidney retinal dehydrogenase, with an apparent K_i of $5.4 \mu\text{M}$. Thus, we asked whether the concentration of 9-*cis*-retinol would influence 9-*cis*-retinoic acid formation from 9-*cis*-retinol in Hep G2 cell homogenates. As can be seen in Figure 6, for two different 9-*cis*-retinol concentrations, the amount of 9-*cis*-retinol added to the assay markedly influenced the rate of 9-*cis*-retinoic acid formation. In good agreement with the K_i value for 9-*cis*-retinol reported by Bhat and colleagues (15), approximately 50% of the apparent 9-*cis*-retinol dehydrogenase activity was inhibited upon addition of $5 \mu\text{M}$ 9-*cis*-retinol. Thus, it would appear that 9-*cis*-retinol can act as a potent regulator of 9-*cis*-retinoic acid formation through action on the 9-*cis*-retinol dehydrogenase present in Hep G2 cells.

Equilibrium Constant of Human cRDH. In our preliminary experiments designed to establish assay conditions that give linear rates of 9-*cis*-retinol formation with respect to time, substrate, and cRDH (enzyme) concentrations, we were struck by the tendency of cRDH to catalyze 9-*cis*-retinol oxidation to near completion. Essentially, we observed that if reactions were incubated for a sufficiently long period, nearly all of the substrate, 9-*cis*-retinol, was converted to 9-*cis*-retinoic acid. To better define this observation, we calculated the equilibrium constant for the oxidation reaction catalyzed by cRDH for our standard assay conditions at 37°C . The equilibrium constant for the reaction catalyzed by cRDH was determined to be 4.9×10^{-9} M. Thus, for human cRDH under our assay conditions at pH 8.0 and 37°C , the equilibrium concentration of 9-*cis*-retinol is nearly 100 times greater than that of 9-*cis*-retinoic acid.

9-*cis*-Retinol Synthesis from *all-trans*-Retinol. Since *in vivo* liver 9-*cis*-retinol levels are very low compared to those

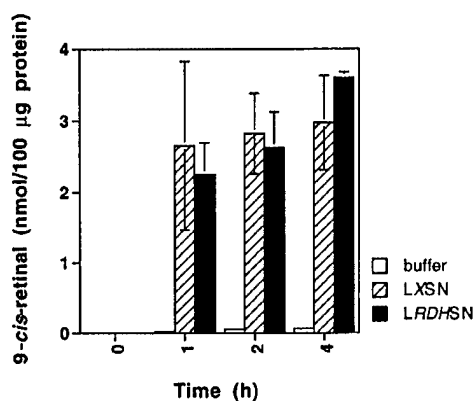

FIGURE 7: 9-*cis*-Retinal synthesis from *all-trans*-retinol. [3 H]-*all-trans*-Retinol (30 nM) was incubated with either LXS/N or LRDHS/N/Hep G2 cell homogenates for indicated time period. Formation of 9-*cis*-retinal was detected by normal-phase HPLC. Results are from triplicate reactions.

of *all-trans*-retinol (see above), we wondered whether cRDH participates in production of 9-*cis*-retinoic acid by efficiently oxidizing available 9-*cis*-retinol to 9-*cis*-retinal. We previously have demonstrated that 9-*cis*-retinol can be formed in a time- and protein-dependent manner when *all-trans*-retinol is incubated in the presence of CHO cell homogenate (22). Hence, we wanted to understand whether 9-*cis*-retinol, upon its formation from *all-trans*-retinol, will immediately be transformed to 9-*cis*-retinal in the presence of cRDH. If this were the case, then liver 9-*cis*-retinol levels would never need to be as great as those of *all-trans*-retinol in order for 9-*cis*-retinoic acid formation to occur. To test this hypothesis, we carried out assays in which *all-trans*-[3 H]retinol (1 μ Ci, 0.03 μ M final concentration) was incubated in the presence of cell homogenates of LRDHSN/Hep G2 or LXS/N/Hep G2 cells and 2 mM NAD $^+$. For this experiment, we chose a concentration of free *all-trans*-retinol (i.e., not bound to cellular retinol-binding protein, type I) that is thought to be present within the liver (44). As seen in Figure 7, 9-*cis*-retinal is formed from *all-trans*-retinol in the presence of either LRDHSN/Hep G2 or LXS/N/Hep G2 cell protein but not in buffer alone. We observed nearly equal quantities of 9-*cis*-retinal formation for the two cell homogenates. This could arise if the conditions used in our experiments were sufficient to allow for an equilibrium or a state of near equilibrium to be reached. Since the concentration of enzyme does not influence equilibrium concentrations of reactants or products, this could account for why we observed equal concentrations of 9-*cis*-retinal for both LRDHSN/Hep G2 and LXS/N/Hep G2 homogenates. Interestingly, for incubations involving both LRDHSN/Hep G2 and LXS/N/Hep G2 homogenates but not buffer alone, a small amount of 9-*cis*-retinol was also detected in the incubation mixtures, indicating that 9-*cis*-retinol was being formed in a protein dependent manner from *all-trans*-retinol (data not shown).

Enzyme Substrate Preference and Kinetic Studies. The recent literature on cRDH suggests that the cRDH enzyme is identical to an enzyme, 11-*cis*-retinol dehydrogenase (11cRDH), that was originally reported to be expressed solely in the eye (6, 16, 45, 46). A recent study by Driessen et al. (17) indicates that recombinant mouse 11cRDH utilizes 9-*cis*-retinol as a substrate and that this enzyme, which was once thought to be restricted to the eye, is expressed in a variety

of tissues outside of the eye. We asked the inverse of the question posed by Driessen et al. (17): will recombinant cRDH expressed in a hepatic cell line catalyze the oxidation of both 9-*cis*- and 11-*cis*-retinol with equal or near equal facility? To address this question, kinetic studies were performed with a crude microsomal fraction obtained from LRDHSN/Hep G2 cells. Microsomal proteins (50 μ g) were incubated with either 0, 1, 2, 3, 4, 5, 7.5, 10, or 15 μ M 9-*cis*- or 11-*cis*-retinol for 5 min at 37 $^{\circ}$ C. Reactions were performed in duplicate for each substrate concentration. Each experiment was repeated at least three times. For different microsomal preparations, the calculated apparent K_m and V_{max} values for 9-*cis*- and 11-*cis*-retinol were reproducible. A representative result is shown in Figure 8. For both substrates, the enzymatic activity follows Michaelis-Menten kinetics, increasing linearly at the lower substrate concentrations but reaching a plateau (zero-order kinetics) for substrate concentrations exceeding approximately 5 μ M. The calculated apparent K_m and V_{max} values for 9-*cis*-retinol were determined by Lineweaver-Burk plots to be approximately 0.44 μ M and 0.126 nmol mg $^{-1}$ min $^{-1}$, and for 11-*cis*-retinol, 1.1 μ M and 0.06 nmol mg $^{-1}$ min $^{-1}$, respectively. Thus, cRDH expressed in human Hep G2 hepatocytes will catalyze the oxidation of both 9-*cis*- and 11-*cis*-retinol with near equal affinity. This observation is consistent with the notion that cRDH and 11cRDH are the same enzyme.

DISCUSSION

Compared to the explosive development in understanding the actions of retinoid nuclear receptors, relatively little is firmly established regarding how their ligands, *all-trans*- and 9-*cis*-retinoic acid, are synthesized in vivo or how their levels are regulated in retinoid target tissues. It is generally accepted that *all-trans*-retinoic acid is formed by two consecutive oxidation events of *all-trans*-retinol (11, 43, 47-49), analogous to ethanol metabolism. Like ethanol oxidation, the rate-limiting step for this process is thought to be the first oxidation reaction, from which *all-trans*-retinal is generated. Several laboratories have recently cloned the cDNAs and genes of *cis*-retinol dehydrogenases that are capable of metabolizing *cis*-retinols to their aldehydes (16-19, 24, 45, 46). The identification of these enzymes argues for the existence of a pathway for 9-*cis*-retinoic acid synthesis in vivo, in which 9-*cis*-retinol is converted to 9-*cis*-retinoic acid by two-step oxidation, similar to *all-trans*-retinoic acid synthesis. For this scenario, the first oxidation step is proposed to be carried out by a *cis*-retinol-specific dehydrogenase(s), followed by a second step catalyzed by a retinal dehydrogenase that is capable of oxidizing either 9-*cis*-retinal or both *all-trans*- and 9-*cis*-retinals to the appropriate retinoic acid isomer (15).

Aside from the metabolism of 11-*cis*-retinoids in the eye, where 11-*cis*-retinal is the necessary visual pigment (6), very little information is available concerning how *cis*-retinoids are processed by cells and tissues. The existence of three distinct *cis*-retinol-specific dehydrogenases that are relatively widely distributed in different tissues (16-19, 24) and of retinal dehydrogenases able to catalyze 9-*cis*-retinal oxidation (15) underscores the importance of understanding how *cis*-retinoids are processed within nonocular tissues. Specifically, the existence of these enzymes raises a question as to if,

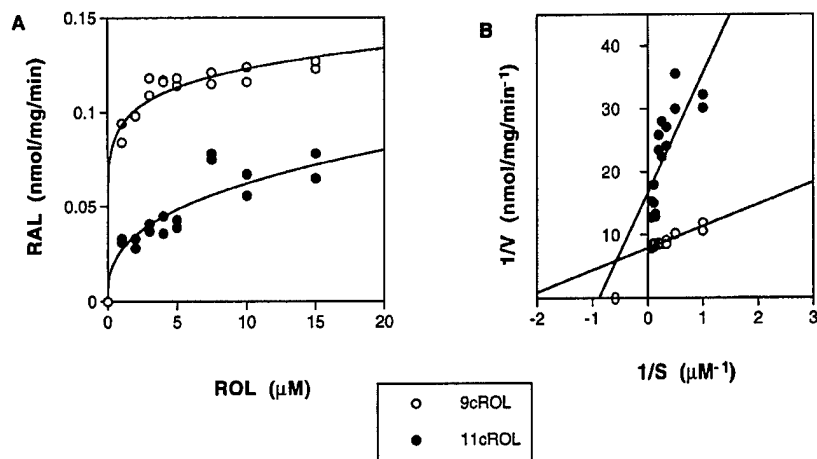

FIGURE 8: cRDH enzyme kinetics and substrate preferences. Microsomes isolated from *LRDHSN/Hep G2* cells were incubated with either 9-*cis*-retinol (O) or 11-*cis*-retinol (●) at various concentrations for 5 min at 37 °C. (A) Production of 9-*cis*-retinal and 11-*cis*-retinal during the reaction period was plotted against substrate concentration. (B) Under our assay conditions, the apparent K_m and V_{max} were 0.44 μM and 0.126 $\text{nmol mg}^{-1} \text{min}^{-1}$ for 9-*cis*-retinol and 1.1 μM and 0.06 $\text{nmol mg}^{-1} \text{min}^{-1}$ for 11-*cis*-retinol, respectively. Shown here is a representative result from three independent experiments.

and how, 9-*cis*-retinoids are processed within tissues and cells. Our studies were carried out to provide insight into this question. First, we examined 9-*cis*-retinol metabolism in hepatocytes and stellate cells, the two main cell types responsible for retinoid storage and metabolism in the liver. We chose to investigate this question in hepatic cells, since both *cis*-retinol dehydrogenases and 9-*cis*-retinol and 9-*cis*-retinyl esters are found in the liver (16–19, 24). As seen in Figures 3 and 4, 9-*cis*-retinol can be loaded into both Hep G2 and HSC-T6 cells from the culture medium and can be used for synthesis of 9-*cis*-retinyl esters in these cells. Interestingly, the Hep G2 cells and the HSC-T6 cells show markedly different properties for 9-*cis*-retinol removal from the medium. For the Hep G2 cells, 9-*cis*-retinol cannot be effectively loaded into cells in the simultaneous presence of *all-trans*-retinol in the medium (Figure 5), while 9-*cis*-retinol loading into HSC-T6 cells is not influenced by the presence of *all-trans*-retinol in the medium (Figures 3C and 5). Moreover, both Hep G2 and HSC-T6 cells possess enzymatic activities for synthesis and hydrolysis of 9-*cis*-retinyl esters. Mata et al. (50) have previously reported that bovine liver possesses a neutral hydrolase activity that is able to hydrolyze *cis*-retinyl esters; however, as far as we are aware, the *in vitro* esterification of 9-*cis*-retinol by liver or liver cell homogenates has not been previously reported.

Since the two liver cell types can be loaded with 9-*cis*-retinol and maintain the 9-*cis*-configuration as well as metabolize 9-*cis*-retinol to esters, we wanted to explore how much 9-*cis*-retinol (or 9-*cis*-retinyl esters) is present within animal tissues. Although not routinely measured in tissues because of the need to use relatively tedious normal-phase HPLC procedures to resolve the geometric isomers of retinol and retinyl esters, 9-*cis*-retinol has been reported to be present in kidney and liver for various species (15, 20, 51, 52). Our data demonstrate that both 9-*cis*-retinol and its fatty acyl esters are present in liver obtained from 3-month-old male mice that had been maintained throughout their life on a control chow diet. These tissue levels of 9-*cis*-retinol and 9-*cis*-retinyl ester are low compared to tissue *all-trans*-retinol and/or *all-trans*-retinyl ester levels, approximately 0.25% that of total *all-trans*-retinol. Nevertheless, it is clear that 9-*cis*-

retinol and its esters are present in liver. Since the three known *cis*-retinol-specific dehydrogenases are reported to be expressed in liver, where 9-*cis*-retinol and/or its esters are located, it would not seem unreasonable to speculate that either one or more of these *cis*-retinol dehydrogenases may act physiologically to catalyze 9-*cis*-retinol oxidation.

Since we could not detect 9-*cis*-retinoids in serum from fasted mice, we do not know the physiologic significance of differential accumulation of retinol isomers by the two liver cell types *in vivo*. However, we cannot rule out the presence of 9-*cis*-retinoid in serum, postprandially in our study. The source of 9-*cis*-retinol in the diet is largely unknown except for the observations of 9-*cis*- β -carotene being a possible precursor (20, 21, 53). Levin and Mokady (9) observed increased level of 9-*cis*-retinol in liver of chicks fed with high 9-*cis*- β -carotene diet. However, total liver retinol level was lower when chicks were fed high 9-*cis*- β -carotene diet compared to ones fed high *all-trans*- β -carotene diet (9). Thus, 9-*cis*- β -carotene appeared to be less efficient compared to *all-trans*- β -carotene as a precursor of retinol. In agreement with Levin and Mokady, You et al. (54) reported 9-*cis*- β -carotene to be a poor precursor of 9-*cis*-retinol in humans due to its high isomerization to *all-trans*- β -carotene upon absorption. In contrast, absorption of 9-*cis*- β -carotene appeared to be similar to *all-trans* configuration in ferrets whose intestine was perfused with either form of β -carotene (21). Moreover, total retinoic acid levels were similar regardless of configuration of β -carotene used except that 9-*cis*-retinoic acid was half the total retinoic acid formed when 9-*cis*- β -carotene was perfused (21). Whether the cell-specific accumulation of retinol isomers observed in our study plays a role *in vivo* needs to be considered in appropriate animal models.

Since Hep G2 cells endogenously express cRDH at low levels ($1/3$ the cRDH mRNA of human liver; Figure 1A), we generated *LRDHSN/Hep G2*, with expression levels of cRDH similar to that in human liver (Figure 1A), to study the pathway of 9-*cis*-retinoic acid synthesis. Using both empty vector-transduced Hep G2 cells (*LXSN/Hep G2* cells) and *LRDHSN/Hep G2* cells, we investigated the ability of these cells to generate 9-*cis*-retinoic acid from 9-*cis*-retinol

added to cell homogenates. Surprisingly, 9-*cis*-retinoic acid formation remained low regardless of cRDH overexpression, even though LRDHSN/Hep G2 cell homogenates showed 6 times more cRDH specific activity (for 9-*cis*-retinol oxidation to 9-*cis*-retinal) than the LXS/N/Hep G2 in vitro (Figure 2C). When examined for the ability to oxidize 9-*cis*-retinal to 9-*cis*-retinoic acid, Hep G2 cells exhibited time- and substrate concentration-dependent production of 9-*cis*-retinoic acid (data not shown). Thus, the absence of retinal dehydrogenase could not be the primary reason for the low level of 9-*cis*-retinoic acid production as well as lack of differences in 9-*cis*-retinoic acid formation from two cell lines, LRDHSN/Hep G2 and LXS/N/Hep G2.

Because Bhat and colleagues (15) have described a retinal dehydrogenase that uses 9-*cis*-retinal as a substrate, which is strongly inhibited by 9-*cis*-retinol (with a K_i of 5.4 μ M), we asked whether 9-*cis*-retinal oxidation could be blocked by high concentrations of 9-*cis*-retinol in Hep G2 cell homogenates. Indeed, as seen in Figure 6, 5 μ M 9-*cis*-retinol inhibited 9-*cis*-retinal oxidation by approximately 50% in the LRDHSN/Hep G2 cell homogenates. Thus, it would appear that Hep G2 cells possess a 9-*cis*-retinol-sensitive retinal dehydrogenase that is similar in this respect to the rat kidney enzyme described by Bhat and colleagues (15).

Low levels of liver 9-*cis*-retinol, compared to those of *all-trans*-retinol, in chow-fed male mice could suggest that 9-*cis*-retinol is not an important physiologic substrate for cRDH; however, we believe that this possibility is unlikely. One of the most striking features of cRDH activity that we have repeatedly observed is its capacity to catalyze 9-*cis*-retinol oxidation to near completion. Under our assay conditions, we have determined the equilibrium constant for the oxidation reaction catalyzed by cRDH to be 4.9×10^{-9} M. Consequently, at equilibrium, the concentration of 9-*cis*-retinal would be expected to be approximately 100 times greater than that of 9-*cis*-retinol. Thus, if some 9-*cis*-retinol were present together with cRDH and sufficient NAD^+ , we would predict that the 9-*cis*-retinol would immediately be transformed to 9-*cis*-retinal. The total intracellular (cytoplasmic) NAD^+ concentration for rat liver is calculated to be approximately 1 mM (55, 56) (a concentration similar to what we employed in our assay condition). Of the total NAD^+ ($\text{NAD}^+ + \text{NADH}$) present in rat liver, approximately 99.9% will be present as NAD^+ . Consequently, with our assay conditions, which reflect those of the liver, one would expect the reaction to go toward 9-*cis*-retinal. We tested this prediction in the experiment reported in Figure 7. When the Hep G2 cell homogenate was incubated with *all-trans*-[^3H]retinol, formation of 9-*cis*-retinal occurred. This finding indicates that the small amount of 9-*cis*-retinol produced through isomerization of *all-trans*-retinol is being oxidized to 9-*cis*-retinal, likely ensuring 9-*cis*-retinoic acid formation. This finding is also in keeping with our observation that high concentrations of 9-*cis*-retinol can strongly inhibit 9-*cis*-retinal oxidation and, hence, 9-*cis*-retinoic acid formation from 9-*cis*-retinol. Considering the inhibitory action of 9-*cis*-retinol on 9-*cis*-retinal oxidation (Figure 6), one would predict that 9-*cis*-retinol might never reach very high levels within cells or tissues, since this would have the effect of shutting down 9-*cis*-retinoic acid formation; a case of the precursor inhibiting product formation. On the basis of these considerations, we believe that cRDH is physiologically

involved in catalyzing a first metabolic step needed for 9-*cis*-retinoic acid formation in the liver.

We and others have reported data that indicate that cRDH is identical to 11-*cis*-retinol dehydrogenase (11cRDH), an enzyme that was originally proposed to be specifically localized to the retinal pigment epithelium (RPE) and to be critically involved in 11-*cis*-retinal formation (6, 16, 45, 46). Contrary to the earlier literature (6, 16, 45, 46), it appears that recombinant human 11cRDH and bovine RPE 11cRDH may equally utilize both 11-*cis*-retinol and 9-*cis*-retinol as substrates (17, 23). We asked whether cRDH, expressed in nonocular tissue, can also use both 9-*cis*- and 11-*cis*-retinol as substrates. As expected, both of these retinol isomers serve as substrates for cRDH derived from LRDHSN/Hep G2 cells. The apparent K_m values for 9-*cis*- and 11-*cis*-retinol were respectively 0.44 and 1.1 μ M. Thus, cRDH expressed in nonocular cells can utilize with nearly equal affinity both retinol isomers as substrates. This observation is consistent with the conclusion that cRDH and 11cRDH are indeed the same enzyme.

Overall, our studies provide evidence that 9-*cis*-retinol is found within tissues of living animals and that hepatic cells are able to incorporate and metabolize 9-*cis*-retinol in a manner that resembles that of *all-trans*-retinol. These findings support the notion that several recently cloned *cis*-retinol-specific dehydrogenases likely catalyze 9-*cis*-retinoic acid formation. Moreover, our data provide new insights into how 9-*cis*-retinoic acid may be formed by tissues and cells and suggest that the metabolism of 9-*cis*-retinoids is highly regulated.

ACKNOWLEDGMENT

We thank Dr. Mark Kay (Stanford University) for the Hep G2 cells. We thank Dr. James R. Mertz, City College of New York, for helpful discussions, Dr. Mary Gamble, Columbia University, for assistance in calculation of the equilibrium constant, and Dr. John C. Saari, University of Washington, for helpful discussions and the gift of 11-*cis*-retinol and 11-*cis*-retinal used in preparation for these studies.

REFERENCES

1. Strickland, S., and Sawey, M. J. (1980) *Dev. Biol.* 78, 76–85.
2. Lotan, R. (1980) *Biochim. Biophys. Acta* 605, 33–91.
3. Rosenthal, D., Lancillotti, F., Darwiche, N., Sinha, R., and De Luca, L. M. (1994) in *Vitamin A in health and disease* (Blomhoff, R., Ed.) pp 425–450, Marcel Dekker, New York.
4. Hofmann, C., and Gregor, E. (1994) in *The Retinoids: Biology, Chemistry, and Medicine* (Sporn, M. B., Roberts, A. B., and Goodman, D. S., Eds.) pp 387–441, Raven Press, New York.
5. Collins, M. D., and Mao, G. E. (1999) *Annu. Rev. Pharmacol. Toxicol.* 39, 399–430.
6. Saari, J. C. (1994) in *The Retinoids: Biology, Chemistry, and Medicine* (Sporn, M. B., Roberts, A. B., and Goodman, D. S., Eds.) pp 351–385, Raven Press, New York.
7. Ross, A., and Hammerling, U. (1994) in *The Retinoids: Biology, Chemistry, and Medicine* (Sporn, M., Roberts, A., and Goodman, D., Eds.) pp 521–544, Raven Press, New York.
8. Armstrong, R. B., Ashenfelter, K. O., Eckhoff, C., Levin, A. A., and Shapiro, S. S. (1994) in *The Retinoids: Biology, Chemistry, and Medicine* (Sporn, M. B., Roberts, A. B., and Goodman, D. S., Eds.) pp 545–572, Raven Press, New York.
9. Levin, G., and Mokady, S. (1994) *Int. J. Vitam. Nutr. Res.* 64, 165–169.

10. Heyman, R. A., Mangelsdorf, D. J., Dyck, J. A., Stein, R. B., Eichele, G., Evans, R. M., and Thaller, C. (1992) *Cell* 68, 397–406.
11. Napoli, J. L. (1996) *FASEB J.* 10, 993–1001.
12. Duester, G. (1996) *Biochemistry* 35, 12221–12227.
13. Urbach, J., and Rando, R. R. (1994) *Biochem. J.* 299, 459–465.
14. Labrecque, J., Bhat, P. V., and Lacroix, A. (1993) *Biochem. Cell. Biol.* 71, 85–89.
15. Labrecque, J., Dumas, F., Lacroix, A., and Bhat, P. V. (1995) *Biochem. J.* 305, 681–684.
16. Mertz, J. R., Shang, E., Piantedosi, R., Wei, S., Wolgemuth, D. J., and Blaner, W. S. (1997) *J. Biol. Chem.* 272, 11744–11749.
17. Driessen, C. A., Winkens, H. J., Kuhlmann, E. D., Janssen, A. P., van Vugt, A. H., Deutman, A. F., and Janssen, J. J. (1998) *FEBS Lett.* 428, 135–140.
18. Su, J., Chai, X., Kahn, B., and Napoli, J. L. (1998) *J. Biol. Chem.* 273, 17910–17916.
19. Chai, X., Zhai, Y., and Napoli, J. L. (1997) *J. Biol. Chem.* 272, 33125–33131.
20. Ben-Amotz, A., Mokady, S., and Avron, M. (1988) *Br. J. Nutr.* 59, 443–449.
21. Hebuterne, X., Wang, X. D., Johnson, E. J., Krinsky, N. I., and Russell, R. M. (1995) *J. Lipid Res.* 36, 1264–1273.
22. Gamble, M. V., Shang, E., Zott R. P., Mertz, J. R., Wolgemuth, D. J., and Blaner, W. S. (1999) *J. Lipid Res.* 40, 2279–2292.
23. Wang, J., Chai, X., Eriksson, U., and Napoli, J. L. (1999) *Biochem. J.* 338, 23–27.
24. Romert, A., Tuvendal, P., Simon, A., Dencker, L., and Eriksson, U. (1998) *Proc. Natl. Acad. Sci. U.S.A.* 95, 4404–4409.
25. Napoli, J. L. (1986) *Methods Enzymol.* 123, 112–124.
26. Swisshelm, K., Ryan, K., Lee, X., Tsou, H. C., Peacocke, M., and Sager, R. (1994) *Cell Growth Differ.* 5, 133–141.
27. Sasaki, T., Hansen, R. S., and Gartler, S. M. (1992) *Mol. Cell. Biol.* 12, 3819–3826.
28. Miller, A. D. (1992) *Curr. Top. Microbiol. Immunol.* 158, 1–24.
29. Miller, A. D., Miller, D. G., Garcia, J. V., and Lynch, C. M. (1993) *Methods Enzymol.* 217, 581–599.
30. Knowles, B. B., Howe, C. C., and Aden, D. P. (1980) *Science* 209, 497–499.
31. Fleischer, S., and Kervina, M. (1974) *Methods Enzymol.* 31, 6–41.
32. Friedman, S. L. (1993) in *In Vitro Biological Systems* (Tyson, C., and Frazier, J., Eds.) pp 292–310, Academic Press, San Diego, CA.
33. Kim, Y., Ratzl, V., Choi, S. G., Lalazar, A., Theiss, G., Dang, Q., Kim, S. J., and Friedman, S. L. (1998) *J. Biol. Chem.* 273, 33750–33758.
34. Vogel, S., Piantedosi, R., Frank, J., Lalazar, A., Rockey, D. C., Friedman, S. L., and Blaner, W. S. (2000) *J. Lipid Res.* 41, 882–893.
35. Blaner, W. S., Das, S. R., Gouras, P., and Flood, M. T. (1987) *J. Biol. Chem.* 262, 53–58.
36. Kurlandsky, S. B., Gamble, M. V., Ramakrishnan, R., and Blaner, W. S. (1995) *J. Biol. Chem.* 270, 17850–17857.
37. Randolph, R. K., and Ross, A. C. (1991) *J. Biol. Chem.* 266, 16453–16457.
38. Ross, A. C. (1982) *J. Biol. Chem.* 257, 2453–2459.
39. Friedman, S. L., Wei, S., and Blaner, W. S. (1993) *Am. J. Physiol.* 264, G947–952.
40. Bridges, C. D., and Alvarez, R. A. (1982) *Methods Enzymol.* 81, 463–485.
41. Blaner, W. S., and Churchich, J. E. (1980) *Biochem. Biophys. Res. Commun.* 94, 820–826.
42. Simon, A., Lagercrantz, J., Bajalica-Lagercrantz, S., and Eriksson, U. (1996) *Genomics* 36, 424–430.
43. Blaner, W. S., and Olson, J. A. (1994) in *The Retinoids: Biology, Chemistry, and Medicine* (Sporn, M. B., Roberts, A. B., and Goodman, D. S., Eds.) pp 229–255, Raven Press, New York.
44. Posch, K. C., Boerman, M. H., Burns, R. D., and Napoli, J. L. (1991) *Biochemistry* 30, 6224–6230.
45. Driessen, C. A., Janssen, B. P., Winkens, H. J., van Vugt, A. H., de Leeuw, T. L., and Janssen, J. J. (1995) *Invest. Ophthalmol. Vis. Sci.* 36, 1988–1996.
46. Simon, A., Hellman, U., Wernstedt, C., and Eriksson, U. (1995) *J. Biol. Chem.* 270, 1107–1112.
47. Napoli, J. L., and Race, K. R. (1987) *Arch. Biochem. Biophys.* 255, 95–101.
48. Napoli, J. L., Boerman, M. H., Chai, X., Zhai, Y., and Fiorella, P. D. (1995) *J. Steroid Biochem. Mol. Biol.* 53, 497–502.
49. Boerman, M. H., and Napoli, J. L. (1996) *J. Biol. Chem.* 271, 5610–5616.
50. Mata, N. L., Mata, J. R., and Tsin, A. T. (1996) *J. Lipid Res.* 37, 1947–1952.
51. Matsui, M., Okano, S., Yamashita, K., Miyano, M., Kitamura, S., Kobayashi, A., Sato, T., and Mikami, R. (1958) *J. Vitaminol.* 4, 178–189.
52. Brown, P. S., Blum, W. P., and Stern, M. H. (1959) *Nature* 184, 1377–1379.
53. Ben-Amotz, A., Mokady, S., Edelstein, S., and Avron, M. (1989) *J. Nutr.* 119, 1013–1019.
54. You, C. S., Parker, R. S., Goodman, K. J., Swanson, J. E., and Corso, T. N. (1996) *Am. J. Clin. Nutr.* 64, 177–183.
55. Veech, R. L., Eggleston, L. V., and Krebs, H. A. (1969) *Biochem. J.* 115, 609–619.
56. Glock, G., and McLean, P. (1956) *Exp. Cell Res.* 11, 234–236.

BI992152G

**CIS-RETINOL DEHYDROGENASE:
9-CIS-RETINOL METABOLISM AND ITS EFFECT ON GROWTH
OF HUMAN MCF7 BREAST CANCER CELLS¹**

Jisun Paik, William S. Blaner, and Karen Swisshelm²

Nutritional Sciences Program, University of Washington, Seattle, WA 98195 [J.P., K.S.],
Department of Medicine and Institute of Human Nutrition, Columbia University, New York,
NY 10032 [W.S.B.], and Department of Pathology, University of Washington, Seattle, WA
98195 [K.S.]

Running Title: *cis*-retinol dehydrogenase in MCF7 cells

Key words: *cis*-retinol dehydrogenase, 9-*cis*-retinol, breast cancer, retinoid metabolism, cell growth

¹This work was supported by a U. S. Army Predoctoral Award DAMD17-97-1-7252 to J.P., a Pilot and Feasibility Award through the University of Washington Clinical Nutrition Research Unit (DK35816) to K.S. and a grant from the NIH (DK52444) to W.S.B.

²To whom requests for reprints should be addressed:

Department of Pathology, Box 357470
1959 N.E. Pacific Street – D-511 HSB
University of Washington
Seattle, WA 98195-7470
Phone: 206-616-3182
FAX: 206-543-3644
e-mail: kswiss@u.washington.edu

³The abbreviations used are: cRDH, *cis*-retinol dehydrogenase; ER, estrogen receptor; EGF, epidermal growth factor; TMMP-ROH, all-*trans*-9-(4-methoxy-2,3,6-trimethylphenyl)-3,7-dimethyl-2,4,6,8-nonatetraen-1-ol; MNNG, *N*-methyl-*N'*-nitro-*N*-nitrosoguanidine; TBS, Tris-buffered saline; PVDF, polyvinylidene difluoride; SDS-PAGE, sodium dodecyl sulfate-polyacrylamide gel electrophoresis; PBS, phosphate buffered saline; PDA, photodiode array detector

INTRODUCTION

Retinoids are needed to maintain and promote health of vertebrates. They act physiologically by participating in vision (1), to regulate cell differentiation (2) and embryonic development (3), to maintain normal reproduction (4) and to assure a healthy immune response (5). The effects of retinoids within the body are mediated through retinoic acid receptors (RARs) and retinoid X receptors (RXRs), which act to regulate gene expression as ligand-dependent transcription factors. The naturally occurring ligands for these nuclear factors are thought to be all-*trans*-retinoic acid for RARs and 9-*cis*-retinoic acid for RXRs (6). While detailed understanding of the molecular actions of the RARs and RXRs in regulating gene transcription is now available (7-9), tissue-specific synthetic pathway(s) for their respective ligands are not well defined or understood. Nevertheless, the therapeutic efficacy of retinoids, including 9-*cis*-retinoic acid, is well established in both tissue culture and animal models of breast cancer (10-12).

Several enzymes that are proposed to be involved in the synthesis of 9-*cis*-retinoic acid have been isolated and characterized (13-19). Among these enzymes, *cis*-retinol dehydrogenase (cRDH), was originally isolated from a human mammary tissue cDNA library (16). Since cRDH mRNA is relatively highly expressed in human mammary tissue (16, 20), we hypothesized that this enzyme may be involved in *in situ* 9-*cis*-retinoic acid production in mammary tissue. Since 9-*cis*-retinoic acid has reported to be growth inhibitory to various estrogen receptor positive (ER⁺) breast cancer cell lines (10, 12, 21-23), we further hypothesized that over-expression of cRDH in breast cancer cells may induce inhibition of cell growth by resulting in excessive production and accumulation of 9-*cis*-retinoic acid within these cells.

The MCF7 human mammary carcinoma cell line was derived from a pleural effusion of a patient with breast adenocarcinoma (24). 9-*cis*-retinoic acid has been demonstrated to be effective in inhibiting proliferation of MCF7 cells (25-27). This cell line is widely used as a model for studying retinoid effects and metabolism in mammary

carcinoma cells (25, 28-30). In this report, we employ MCF7 cells to examine the potential role of cRDH in 9-*cis*-retinol metabolism in mammary cells. Since MCF7 cells express relatively low levels of cRDH mRNA and activity, we introduced cRDH cDNA by retroviral vector (*LRDHSN*) into MCF7 cells to express a high level of this enzyme. Using this model system, we demonstrate that cRDH oxidizes 9-*cis*-retinol to 9-*cis*-retinal and that the combined effects of cRDH over-expression and 9-*cis*-retinol treatment result in a suppression of MCF7 cell proliferation. Overall, our experiments provide new insights concerning the pathways of 9-*cis*-retinol metabolism in breast-derived cells and suggest that 9-*cis*-retinol and its metabolites can influence cancer cell growth independent of its conversion to retinoic acid.

MATERIALS AND METHODS

Tissue culture. MCF7, human breast cancer cell line, was obtained from the American Type Culture Collection (ATCC, Manassas, VA) and were found to be free of mycoplasma as assessed by the method of Russel *et al.* (31). MCF7 cells were cultured in complete tumor media (α -Modified Eagle's medium (α -MEM), containing epidermal growth factor (EGF), insulin, and hydrocortisone) (32) at 37° C in an atmosphere of 5% CO₂. Transduced MCF7 cells were first cultured in complete tumor media containing G418 (0.75 mg/ml) to select cells harboring the viral vectors. Thereafter, the transduced MCF7 cells were cultured in complete tumor media.

Insulin, EGF, and hydrocortisone were purchased from Sigma (St. Louis, MO), G418 was obtained from Calbiochem (San Diego, CA), and α -MEM was purchased from Gibco (Rockville, MD).

Retinoids. All-*trans*-, 13-*cis*-retinol, all-*trans*-, 9-*cis*-, and 13-*cis*-retinal were purchased from Sigma. The internal standards employed for HPLC analyses, all-*trans*-9-(4-methoxy-2,3,6-trimethylphenyl)-3,7-dimethyl-2,4,6,8-nonatetraen-1-ol (TMMP-ROH,

Ro12-0586) (33) and all-*trans*-7-(1,3,3,3,-tetramethyl-5-indanyl-3-methyl-octa-2,4,6-trienoic acid (TIMOTA) were obtained from Dr. Louise H. Foley (Hoffmann-LaRoche, Inc, Nutley NJ). 9-*Cis*-retinol was prepared by reducing 9-*cis*-retinal with NaBH₄ as described by Mertz *et al* (16). 9-*Cis*-[³H]retinol was prepared from 9-*cis*-[³H-methyl-C₂₀]retinoic acid (New England Nuclear, Boston, MA) following the method described by Blaner *et al.* with slight modification (34). Briefly, 9-*Cis*-[³H]retinoic acid was first esterified to its methyl ester using *N*-methyl-*N'*-nitro-*N*-nitrosoguanidine (MNNG) (Sigma) and then converted to 9-*cis*-[³H]retinol by reductive hydrolysis with LiAlH₄ (Sigma). The resulting 9-*cis*-[³H]retinol was purified by 10% deactivated alumina (ICN, Irvine, CA), reconstituted in 100% ethanol after drying under gentle nitrogen stream, and stored at -20° C until use. On the day of experiments, 9-*cis*-[³H]retinol was added to unlabeled 9-*cis*-retinol to a final concentration of 1 μM and a specific activity of 400,000 cpm/p60 mm² tissue culture plate.

Transduction of MCF7 cells with cRDH. The transduction of MCF7 cells with cRDH was performed using a retroviral vector following the method described previously (19). The resulting cell lines are referred to as LXSN/MCF7 (empty vector) and LRDHSN/MCF7 (cRDH containing vector). Both clonal and mass-culture cell lines of LXSN/MCF7 and LRDHSN/MCF7 were established. Successful transduction was determined by mRNA and protein expression of cRDH using Northern blot and Western blot analyses, as previously described (19). Briefly, for Northern blot analysis, total RNA (20 μg) from LXSN/MCF7 and LRDHSN/MCF7 clonal cell lines was loaded onto 1.2% denaturing agarose gel and blotted onto a membrane (Zeta-probe membrane, BioRad, Hercules, CA). A ³²P-labeled (α-dCTP) probe was prepared from the full-length human cRDH cDNA using a Random prime labeling kit (Roche Molecular Biochemicals, Indianapolis, IN) according to the manufacturer's instructions. Hybridization was carried out overnight at 42°C. The final wash was 2 × SSC/0.1% SDS at 65°C and the blot was exposed to X-ray film for autoradiography. For Western blot analysis, whole cell extracts were prepared by lysing cells with Tris-buffered saline (TBS, 10mM Tris, pH 7.5, 150 mM

NaCl) containing Triton X-100 (0.5 %) for 30 min on ice and by removing cell debris and the nuclear portion by centrifugation at 10,000 g for 10 min. The whole cell extracts for each clonal cell line (5-10 μ g protein) were loaded on 12% SDS-PAGE and blotted to polyvinylidene difluoride (PVDF) membrane (BioRad) at 30 V overnight at 4°C. Following incubation in 2% milk blocking solution for 1 h, the membrane was incubated with rabbit anti-human cRDH antibody (35) (1:5000) for 1 h at room temperature. After washing with PBS containing 0.1% Tween 20, the membrane was incubated with a secondary goat-anti-rabbit antibody conjugated to horseradish peroxidase (1:2000 dilution, Santa Cruz, Santa Cruz, CA). ECL reagents (Pierce) were used to visualize the signal per manufacturer's recommendation.

Growth kinetic studies. Both mass-transduced cell lines and two independent clonal cell lines derived from the *LRDHSN/MCF7* and *LXSN/MCF7* cells were used for growth kinetic studies. Cells were plated at 100,000/T25 mm² tissue culture flask and grown in complete tumor media supplemented with either 1 μ M 9-*cis*-retinol or the equivalent volume of vehicle alone (ethanol). Media was changed every 48 h. Cells were counted using a hemocytometer on days 1, 3, 5, and 7. In some experiments, 9-*cis*-retinal was used instead of 9-*cis*-retinol.

Metabolism studies. Both long term (7 d) and short term (24 h) studies were carried out to investigate 9-*cis*-retinoid metabolism in *LRDHSN/MCF7* and *LXSN/MCF7* cell lines (clonal and/or mass-culture). For the long term studies, two clonal cell lines derived from the *LRDHSN/MCF7* cells (clone 2 and 4) and from the *LXSN/MCF7* cells (clone 5 and 6) were plated at 100,000/T25 mm² flask and were cultured for up to 7 d in complete tumor media with either 1 μ M 9-*cis*-retinol or vehicle alone. On days 1, 3, 5, and 7, media (2 ml) and cells (trypsinized and pelleted in 1 ml PBS) were collected, and cell numbers were determined using a hemocytometer. Cell and media samples were stored at -70° C for subsequent analysis of retinol/retinal and retinoic acid concentrations. For the short term studies, either clonal lines or mass-culture cell lines of *LXSN/MCF7* and *LRDHSN/MCF7* were plated at 500,000/p60 mm² tissue culture plate. The next morning,

media was changed to include either 9-*cis*-retinol, 9-*cis*-retinal or vehicle (ethanol) alone. Cells were scraped in 1 ml PBS and, together with the media, were collected at 0, 0.5, 1, 4, 8, and 24 h after addition of the 9-*cis*-retinoids and stored at -70°C until HPLC analysis for retinoid contents.

Retinoid extraction and HPLC analysis. Cells and media were denatured with an equal volume of 100% ethanol (1 ml) and extracted with 2.5 ml hexane for retinol/retinal analysis. The extracts were analyzed by normal phase HPLC on a 4.6 X 150 mm Supelcosil LC-Si column (Supelco, Bellefonte, PA) using hexane:ethyl acetate:butanol (96.9:3.0:0.1, v:v) as the running solvent (0.8 ml/min). For retinoic acid measurements, cell homogenates and media were extracted with 6 ml chloroform:methanol (2:1, v/v) and the lower retinoid-containing chloroform phase was analyzed by HPLC. Two tandem silica columns consisting of a 3.9 x 150 mm Resolve Silica column (Waters Associates, Milford MA) and a 4.6 x 150 mm Supelcosil LC-Si column (Supelco) were employed for retinoic acid measurement, using hexane:acetonitrile:acetic acid (99.5: 0.4: 0.1, v/v) as the running solvent (1.8 ml/min) (36). A Waters 996 Photodiode array detector (PDA) was used for the detection of retinoids following absorbance at 325 nm for retinol, at 365 nm for retinal, and at 350 nm for retinoic acid. Each HPLC peak was identified and quantified by comparing retention times, spectra and area under the peak to those obtained using authentic standards for each retinoid. Loss during extraction was accounted for by adjusting the recovery to that of the internal standards, TMMP-ROH for retinol/retinal and TIMOTA for retinoic acid.

Measurement of cRDH enzymatic activity. Total cell homogenate protein (100 μg) was obtained from LRDHSN/MCF7 cells or LXSN/HepG2 cells (19) were incubated with 10 μM 9-*cis*-retinal for 20 min at 37°C in the presence or absence of 2 mM NAD^{+} in the buffer containing 10 mM HEPES, pH 8.0, 150 mM KCl, and 1 mM EDTA (assay buffer). Production of 9-*cis*-retinoic acid was determined by HPLC as described above.

Studies of 9-*cis*-[³H]retinol metabolism. Mass cultures of LXSN/MCF7 and LRDHSN/MCF7 were plated at 500,000/p60 mm² tissue culture plate. The next day, the media was changed to include 1 μ M 9-*cis*-[³H]retinol (approximately 400,000 cpm/p60 mm² plate). Cells and media were collected at 0, 0.5, 1, 4, 8, and 24 h following the change of media and subsequently analyzed for retinol/retinal and retinoic acid contents. Concentrations of retinoids and the radioactivity associated with them were measured sequentially using the PDA detector and an in-line radioactivity monitor (Berthold LB506C-1; EG&G Berthold). The Berthold radioactivity monitor was employed Monoflow 2 (National Diagnostics, Somerville, NJ) as a scintillant flowing at twice the rate of the running solvent. To assess recovery of the radiolabel upon extraction, the radioactivity associated with both the organic- and water-soluble phases was determined following extraction of the media with chloroform:methanol (2:1, v:v). Aliquots from both the organic- or water-soluble phases were dried and reconstituted in Hydroflour liquid scintillation counting solution (National Diagnostics), and radioactivity was measured with a Beckman LS-1800 liquid scintillation counter.

RESULTS

Transduction of cRDH into MCF7 cells. To study the potential effects of cRDH expression in human breast cancer cells, we created a model system using the ER⁺ breast cancer cell line, MCF7. Using a retrovirus containing the full length human cRDH cDNA (Fig. 1A), we generated both mass-culture and clonal cell lines (see below) that we refer to as LRDHSN/MCF7 cells. These cells express relatively high levels of human cRDH (Fig. 1B and C). To serve as a control, cell lines transduced with an empty retrovirus, termed LXSN/MCF7 cells, were also developed. Successfully transduced cells were selected with G418 and clonal cell lines (8 each) were established. All clonal cell lines were examined for cRDH mRNA and protein expression by Northern blot (Fig. 1B) and Western blot analysis (Fig. 1C). The LRDHSN/MCF7 and LXSN/MCF7 clonal cell lines were also examined by Southern blot analysis (data not shown) to

examine copy numbers of exogenous incorporated genes. Those showing the expected size transcripts with one or two gene integrants were employed for our studies investigating the growth characteristics of the cells and the metabolism of 9-*cis*-retinol (LRDHSN/MCF7 clones 2 and 4, LXS/N/MCF7 clones 5 and 6; Fig. 1B and C). In some cases, mass-culture cell lines were also utilized in our studies to avoid potential differences in growth behavior that are often observed among clonal cell lines (37). The mass-culture cell lines selected with G418 represent a mixed population of G418-resistant clones that we estimate arose from a starting population of approximately 1000–1500 transduced cells.

cRDH transduction results in growth inhibition of MCF7 cells treated with 9-*cis*-retinol. To examine the possible role of cRDH in modulating the growth of MCF7 cells, mass-cultures of LRDHSN/MCF7 and LXS/N/MCF7 cells were grown in media supplemented with either 1 μ M 9-*cis*-retinol or the equivalent volume of vehicle alone (100% ethanol). The LRDHSN/MCF7 cells exhibited profound growth inhibition (70%) upon the treatment with 1 μ M 9-*cis*-retinol compared to the treatment with vehicle alone (Fig. 2A). Similar results were obtained when clonal cell lines were utilized showing an average growth reduction of 80% when LRDHSN/MCF7 cells treated with 9-*cis*-retinol as compared to vehicle (data not shown). The growth inhibition was observed in only cRDH transduced cells but not in empty vector transduced cells.

Since all-*trans*-retinol is known to suppress MCF7 cell growth (21), we investigated whether the growth inhibition observed in LRDHSN/MCF7 cells treated with 9-*cis*-retinol was due to all-*trans*-retinol that might be produced through isomerization of 9-*cis*-retinol in either media or cultured cells. The LRDHSN/MCF7 mass-culture cells were treated with either 1 μ M 9-*cis*-retinol, all-*trans*-retinol, or vehicle alone for 7 days (Fig 2B). Growth inhibition was observed in cells treated with either all-*trans*-retinol or 9-*cis*-retinol, but the degree of inhibition observed with all-*trans*-retinol treatment was less than that observed upon treatment with 9-*cis*-retinol. (21% vs. 65% inhibition, Fig. 2B).

9-*cis*-retinoid metabolism in transduced MCF7 cells. To identify the compound(s) involved in the growth inhibitory effect produced upon 9-*cis*-retinol treatment of LRDHSN/MCF7 cells, we analyzed the retinoid contents of both LXS/N/MCF7 (clone 5 and 6) and LRDHSN/MCF7 (clone 2 and 4) cells and their media. Two independent experiments were performed and good agreement was observed for the two. Results of one representative experiment are shown in Fig. 3. The amount of 9-*cis*-retinol in the media of treated LRDHSN/MCF7 cells declined rapidly over the 7 d time course of this study from 1000 pmol/ml to 160 pmol/ml by day 7 (Fig. 3A). This is probably due to uptake of 9-*cis*-retinol by the LRDHSN/MCF7 cells followed by its oxidation to 9-*cis*-retinal catalyzed by cRDH. In contrast, 9-*cis*-retinol levels in the media of LXS/N/MCF7 cells remained relatively high (~550 pmol/ml) throughout the duration of the experiment (Fig. 3A). The product of cRDH catalysis, 9-*cis*-retinal, was detected in media from LRDHSN/MCF7 cells but not in media from LXS/N/MCF7 cells (Fig. 3A). When retinoid forms and concentrations were analyzed for the cells (Fig. 3B), for both cell lines, cellular levels of both 9-*cis*-retinol and 9-*cis*-retinal were lower than those detected in the media. Taken together, these data suggest that both LRDHSN/MCF7 and LXS/N/MCF7 cells take up 9-*cis*-retinol, however only LRDHSN/MCF7 cells oxidize it to 9-*cis*-retinal.

Retinoic acid concentrations were also analyzed for cells and media. 9-*Cis*-retinoic acid could not be detected in either cells or media of both cell lines (data not shown). This may indicate that any 9-*cis*-retinoic acid formed from 9-*cis*-retinol oxidation may be rapidly metabolized to more polar compounds. To investigate this possibility, we cultured LXS/N/MCF7 and LRDHSN/MCF7 clonal cells in either 1 μ M 9-*cis*-retinol or vehicle alone for a 24 h period (data not shown). Cells and media were collected at 0.5, 1, 4, 8, and 24 h and analyzed for retinoid profiles. The trend of 9-*cis*-retinol and 9-*cis*-retinal levels in cells and media were similar to what was observed in 7-day metabolism studies. We detected 9-*cis*-retinal presence in both LRDHSN/MCF7 cells and media but not in LXS/N/MCF7 cells and media. However, 9-*cis*-retinoic acid could not be detected for any time points for both cell line.

Examination of retinal oxidizing enzyme(s) in MCF7 cells. In order to understand why *LRDHSN/MCF7* cells are able to oxidize *9-cis*-retinol to *9-cis*-retinal but yet *9-cis*-retinoic acid, an oxidation product of *9-cis*-retinal, was not detected in either cells or media, we investigated the possibility that MCF7 cells lack a retinal dehydrogenase(s) activity that can oxidize *9-cis*-retinal. An *in vitro* enzyme assay was carried out to test for the presence of a putative retinal dehydrogenase(s) in *LRDHSN/MCF7* cells (clone 2). Cell homogenates of *LRDHSN/MCF7* cells and *LXSN/Hep G2* cells (a cell line that expresses *9-cis*-retinal dehydrogenase activity (19)) were incubated with 10 μ M *9-cis*-retinal and the production of *9-cis*-retinoic acid were measured. *LRDHSN/MCF7* cell homogenates produced essentially no *9-cis*-retinoic acid under conditions where comparable amounts of *LXSN/Hep G2* homogenate protein showed significant ability to catalyze *9-cis*-retinal oxidation (Fig. 4). This same experiments was also carried out using total homogenate protein from *LXSN/MCF7* clonal cells (clone 6) and the same result was obtained (data not shown).

The fate of *9-cis*-[³H]retinol. Based on our findings reported above, MCF7 cells did not appear to oxidize *9-cis*-retinal to *9-cis*-retinoic acid. Nevertheless, the disappearance of *9-cis*-retinol from media of *LRDHSN/MCF7* could not be accounted for by the levels of *9-cis*-retinal in the cells and media. Thus, we hypothesized that *9-cis*-retinol and/or its metabolite, *9-cis*-retinal, can be converted to a compound or compounds other than *9-cis*-retinoic acid. To increase sensitivity of detecting metabolites of *9-cis*-retinol, we employed *9-cis*-[³H]retinol and followed its metabolic fate in mass-cultures of *LXSN/MCF7* and *LRDHSN/MCF7* cells over 24 h. The *9-cis*-[³H]retinol was synthesized from *9-cis*-[³H]retinoic acid, where methyl group present as carbon-20 was tritiated. By using retinol labeled at the C-20 position, it was possible to avoid loss of radioactivity resulting from oxidation of retinol at the C-15 position. *LXSN/MCF7* and *LRDHSN/MCF7* cells (500,000 cells/p60 mm² plate) were cultured for 24 h in complete media containing 1 μ M *9-cis*-retinol (400,000 ³H-cpm/plate). At predetermined time points, both cells and media were

collected and analyzed for retinoid forms and contents by HPLC. Glucuronides and other water soluble metabolites were estimated by assessing the quantity of ^3H -cpm associated with aqueous phase after extraction of the media with chloroform:methanol (2:1, v:v) (data not shown). Approximately 96-100% of the ^3H -cpm associated with the media remained in the organic phase upon extraction with chloroform:methanol. This indicates that glucuronidation was not a major pathway for metabolism of 9-*cis*-retinol in MCF7 cells. Little or no 9-*cis*-retinyl ester was detected upon analyses of either cells or media for both LXS/N/MCF7 and LRDHSN/MCF7 cell lines (data not shown).

Analysis of radioactivity associated with retinol/retinal isomers using an in-line HPLC radiation monitor confirmed the results of the metabolism studies reported above. Only LRDHSN/MCF7 cells and not LXS/N/MCF7 cells are able to convert 9-*cis*-retinol to 9-*cis*-retinal, as 9-*cis*-[^3H]retinal was detected only in cells and media of LRDHSN/MCF7 (data not shown). As we expected, 9-*cis*-[^3H]retinol levels remained higher in media and cells of LXS/N/MCF7 compared to LRDHSN/MCF7, and 9-*cis*-[^3H]retinal could not be detected in either cells or media of LXS/N/MCF7 (data not shown). As we hypothesized, upon HPLC analysis we detected an unknown peak (P_{290}) containing ^3H -cpm, with a retention time (~ 19 min) slightly preceding 13-*cis*-retinol in our normal phase HPLC system (Fig. 5A). P_{290} was observed only in cells and media of LRDHSN/MCF7 treated with 9-*cis*-[^3H]retinol and not in cells or media of LXS/N/MCF7. Spectral analysis of the unknown peak on the PDA detector revealed that the unknown compound maximally absorbed at 290-300 nm (Fig. 5B). This indicates that P_{290} is distinct from known retinols and retinals, which show absorption maxima at approximately 325 nm and 365 nm, respectively (38).

Several other unidentifiable peaks of ^3H -cpm were also detected during HPLC analysis of LRDHSN/MCF7 cells and media. However, identification of these compounds was difficult, since these ^3H -cpm peaks corresponded to UV peaks that were too small to get a useful UV spectrum from the PDA detector or that coeluted with the internal standard,

TIMOTA that we use to assess retinoid recovery upon extraction and analysis of retinoids (see Materials and Methods).

P₂₉₀ is likely a metabolite of 9-*cis*-retinal. Since P₂₉₀ was detected in the cells and media of *LRDHSN/MCF7* treated with 9-*cis*-[³H]retinol but not in those of *LXSN/MCF7*, we asked whether P₂₉₀ is a metabolite of 9-*cis*-retinal. If this were the case, we should detect P₂₉₀ in both *LXSN/MCF7* and *LRDHSN/MCF7* cells and media upon treatment with 9-*cis*-retinal. To test this, we cultured *LXSN/MCF7* and *LRDHSN/MCF7* mass-culture cells in media containing 1 μM 9-*cis*-retinal for up to 24 h and analyzed retinoid profiles from cells and media for both cell lines. We examined chromatograms of retinoid extracts from cells and media at 300 nm as the maximum absorption of P₂₉₀ was at 290-300 nm (Fig. 5B) and thus, for P₂₉₀, the signal to noise ratio obtained from the HPLC would be the smallest at around 300 nm. The area under the curve (AUC) of the unknown peak at 300 nm was calculated and this value is presented in Fig. 6. P₂₉₀ was detected from both cell lines when treated with 9-*cis*-retinal (Fig. 6), suggesting that the compound is indeed a metabolite of 9-*cis*-retinal.

Unexpectedly, a marked difference in retinoid profiles was observed between *LXSN/MCF7* and *LRDHSN/MCF7* treated with 1 μM 9-*cis*-retinal. While, *LXSN/MCF7* cells appeared to rapidly convert 9-*cis*-retinal to 9-*cis*-retinol, *LRDHSN/MCF7* cells contained higher concentrations of 9-*cis*-retinal and barely detectable levels of 9-*cis*-retinol (Fig. 7). cRDH is capable of both oxidation of 9-*cis*-retinol and reduction of 9-*cis*-retinal *in vitro*. However, our data suggest that cRDH, for the culture conditions employed in our studies oxidizes 9-*cis*-retinol to 9-*cis*-retinal and another enzyme(s) is likely present within *MCF7* cells that actively catalyzes 9-*cis*-retinal reduction

9-*cis*-retinal or its metabolites are responsible for growth inhibition of cRDH transduced MCF7 cells. As we discussed earlier, *LRDHSN/MCF7* cells were growth inhibited upon treatment with 9-*cis*-retinol even though 9-*cis*-retinoic acid was not detected in either the cells or media. Since 9-*cis*-retinol treatment of *LXSN/MCF7* cells did

not affect these cells, it appeared that either a metabolite or metabolites of 9-*cis*-retinol in cRDH transduced cells must account for the observed inhibition. The unique metabolites of 9-*cis*-retinol that are present in LRDHSN/MCF7 cells and media, as compared to those of LXS/N/MCF7, are 9-*cis*-retinal and several unknown metabolites including P₂₉₀ (see above). Hence, we asked whether 9-*cis*-retinal treatment can induce cell growth inhibition in LXS/N/MCF7 and LRDHSN/MCF7 cells. If 9-*cis*-retinal is responsible for the growth inhibition, we would expect to observe suppression of cell proliferation in both cell lines. We first carried out a study where both cell lines were cultured in media containing a range of 9-*cis*-retinal concentrations (0-10 μ M, data not shown). For this study, the two highest 9-*cis*-retinal concentrations (5 and 10 μ M) were found to be cytotoxic, resulting in cell death within 24 h. The lowest concentration, 0.1 μ M, did not affect the growth kinetics of either cell lines. Based on these results, we decided to further investigate the effect of 0.1 and 1 μ M 9-*cis*-retinal on cell growth of the cRDH transduced MCF7 cells. Thus, cells were plated at 100,000/T25 mm² flask and were cultured in either 0.1 μ M or 1 μ M 9-*cis*-retinal, and cell numbers were determined at 1, 3, 5 and 7 days after plating. Because the vehicle alone and 0.1 μ M 9-*cis*-retinal showed similar growth kinetics in previous experiment (data not shown), the vehicle control was not included in the latter experiment. One μ M 9-*cis*-retinal inhibited growth of both LXS/N/MCF7 and LRDHSN/MCF7 cells compared to 0.1 μ M 9-*cis*-retinal treatment. However, LRDHSN/MCF7 cells showed a greater degree of growth suppression compared to LXS/N/MCF7 cells under the same treatment (46% vs. 30%, Fig. 8).

DISCUSSION

The efficacy of 9-*cis*-retinoic acid for preventing and treating breast cancer has been explored in both cell culture and animal models (10, 12, 21-23). In these model systems, 9-*cis*-retinoic acid is as potent, if not more potent, than all-*trans*-retinoic acid in inhibiting

mammary cancer cell growth. Our previous studies with *LRDHSN/Hep G2*, a human hepatoma cell line that overexpresses cRDH, demonstrates that cRDH catalyzes the oxidation of *9-cis-retinol*, a first oxidative step needed for *9-cis-retinoic acid* formation (19). Based on these considerations, we hypothesized that introduction of cRDH into breast cancer cells would increase production and possibly accumulation of *9-cis-retinoic acid* within the cells and that this would result in growth inhibition of the breast cancer cells. To test this hypothesis, we created and characterized a cell line, *LRDHSN/MCF7*, that expresses high levels of cRDH by retroviral transduction. MCF7 cells were chosen because the growth inhibitory effect of *9-cis-retinoic acid* has been observed for ER⁺ breast cancer cell lines. Moreover, earlier we had assessed endogenous cRDH mRNA expression by RT-PCR among a panel of breast cancer cell lines (MCF7, MDA-MB-231, Hs578t, T47D) and found that MCF7 cells showed the lowest levels of endogenous cRDH expression (data not shown).

In keeping with our hypothesis, we observed that treatment of cRDH transduced MCF7 cells, but not of empty vector transduced MCF7 cells, with 1 μ M *9-cis-retinol* markedly inhibited cell proliferation (Fig. 2A). This result indicates that cRDH activity is required to bring about growth suppression by *9-cis-retinol*. In addition, *9-cis-retinol* treatment resulted in a greater growth inhibition of the *LRDHSN/MCF7* cells than treatment of these cells with the same concentration of *all-trans-retinol* (Fig. 2B), suggesting that the observed growth inhibitory effect by *9-cis-retinol* treatment is unlikely due to isomerization of *9-cis-retinol* to *all-trans-retinol*. Taken together, these data suggest that cRDH expression is necessary for bringing about the growth inhibition observed for *LRDHSN/MCF7* cells upon treatment with *9-cis-retinol* and that this inhibition arises through the actions of a metabolite(s) of *9-cis-retinol*.

To investigate further whether this growth inhibition was due to the production and/or over accumulation of *9-cis-retinoic acid* in *LRDHSN/MCF7* cells treated with *9-cis-retinol*, we analyzed cells and media of *LXSN/MCF7* and *LRDHSN/MCF7* for *all-trans-*

and 9-*cis*-retinoic acid. Both for long term (7 days) and short term (24 h) experiments, 9-*cis*-retinol was avidly metabolized to 9-*cis*-retinal by *LRDHSN/MCF7* cells (Fig. 3), however, 9-*cis*-retinoic acid was not detected for either cells or media of *LRDHSN/MCF7*. Since 9-*cis*-retinoic acid was not detected even for the earliest time point examined (30 min after the treatment with 9-*cis*-retinol), it seemed unlikely to us that the apparent lack of 9-*cis*-retinoic acid production from 9-*cis*-retinol could result from its subsequent rapid oxidative/catabolic metabolism. Next, we investigated whether *MCF7* cells possess the enzymatic machinery needed to oxidize 9-*cis*-retinal to 9-*cis*-retinoic acid. These *in vitro* investigations failed to demonstrate that *MCF7* cells possess a 9-*cis*-retinal dehydrogenase(s) activity and thus these cells appear to be unable to catalyze the oxidation of 9-*cis*-retinal to 9-*cis*-retinoic acid (Fig. 4). Based on these data, it is unlikely that the growth inhibition seen in *LRDHSN/MCF7* cells upon treatment with 9-*cis*-retinol arises from accumulation of 9-*cis*-retinoic acid within these cells. Thus, it would appear that 9-*cis*-retinol exerts a robust growth suppression in cRDH transduced *LRDHSN/MCF7* cells without being metabolized to 9-*cis*-retinoic acid, an active retinoid form needed for regulating gene transcription. A similar defect in retinal oxidation was reported in NMU-induced mammary carcinoma in rats as compared to normal mammary tissue (39). Chen *et al.* also have demonstrated that *MCF7* cells are unable to oxidize all-*trans*-retinol to all-*trans*-retinoic acid (29). However, these authors did not show whether the blockage that prevents all-*trans*-retinoic acid formation arises due to an inability of the cells to catalyze retinol oxidation and/or retinal oxidation. Thus, it appears that tumor tissue and cells may lose the ability to produce retinoic acid from retinol. At present, it is not known whether these or similar "defects" in retinoid metabolism occur *in situ* at primary sites of human breast cancer.

Since 9-*cis*-retinol inhibited growth of *LRDHSN/MCF7* cells (Fig. 2A) without being converted to 9-*cis*-retinoic acid, we concluded that other metabolites of 9-*cis*-retinol must be considered as having potential growth inhibitory effect. Since only

LRDHSN/MCF7 and not *LXSN/MCF7* cells showed a diminished rate of growth upon the treatment with *9-cis-retinol*, a prime candidate for causing the observed growth suppression was *9-cis-retinal*. *9-Cis-retinal* at 1 μM indeed induced growth suppression for both *LXSN/MCF7* and *LRDHSN/MCF7* cells (Fig. 8). This suggests that the growth inhibition observed in *LRDHSN/MCF7* cells treated with *9-cis-retinol* is at least partly due to *9-cis-retinal* formation catalyzed by cRDH. In keeping with this notion, *LRDHSN/MCF7* cells exhibited greater degree of growth inhibition compared to *LXSN/MCF7* upon treatment with *9-cis-retinal* (Fig. 8). Analysis of the retinoids present in two cell types treated with *9-cis-retinal* revealed that both cell types take up *9-cis-retinal* but *LRDHSN/MCF7* cells maintained higher concentrations of *9-cis-retinal* through out the experimental period (Fig 7). This could be taken to indicate that higher intracellular concentrations of *9-cis-retinal* may be responsible for the greater growth inhibition observed in *LRDHSN/MCF7* cells as compared to *LXSN/MCF7* cells.

Although *9-cis-retinal* may be responsible for some of the growth inhibition observed in *LRDHSN/MCF7* cells upon treatment with *9-cis-retinol*, we do not believe that all of the growth inhibition seen in *LRDHSN/MCF7* cells upon *9-cis-retinol* treatment arises from *9-cis-retinal* production. This is because treatment of *LRDHSN/MCF7* cells with 1 μM *9-cis-retinol* results in more robust growth inhibitory effect than does treatment with 1 μM *9-cis-retinal* (Fig. 2A vs. Fig. 8). This discrepancy in growth inhibitory effects is observed even though treatment of the *LRDHSN/MCF7* cells with 1 μM *9-cis-retinal* results in greater intracellular accumulation of *9-cis-retinal* than is observed upon treatment with *9-cis-retinol*. This may indicate that other metabolite(s) of *9-cis-retinol*, downstream of *9-cis-retinal*, contribute to the growth inhibition and that cRDH expression is required for efficient metabolic channeling the *9-cis-retinol* for the production of this compound through *9-cis-retinal*. Alternatively, *9-cis-retinol* may be taken up more readily into MCF7 cells compared to *9-cis-retinal* when high levels of cRDH are expressed within these cells.

Although at present it is not possible to evaluate the validity of these or other alternatives for our findings, it is clear that the formation of 9-*cis*-retinal alone cannot account fully for the growth inhibition observed for LRDHSN/MCF7 cells treated with 9-*cis*-retinol.

Because the disappearance of exogenous 9-*cis*-retinol from the culture media greatly exceeded 9-*cis*-retinal accumulation in LRDHSN/MCF7 cells and media (Fig. 3), we investigated possible alternative metabolic pathway(s), including glucuronidation and esterification, which might be responsible for 9-*cis*-retinol disappearance from media. Significant amounts of either 9-*cis*-retinol glucuronidation or 9-*cis*-retinol esterification was not observed to occur in MCF7 cells. The lack of esterification of 9-*cis*-retinol was not surprising in light of the earlier report by Chen *et al.* demonstrating insignificant ester formation from all-*trans*-retinol in MCF7 cells (29). In this regard, the MCF7 cells are unlike Hep G2 hepatocytes and HSC-T6 stellate cells which readily take up and esterify 9-*cis*-retinol (19). Interestingly, a decreased level of retinyl ester formation has also been observed in NMU-induced mammary tumors in rats (39). However, for this rodent tumor model, *in vitro* enzyme assays employing tumor homogenates did not show a diminished amount of esterifying activity present in the tumor tissue, thus, it was concluded for these studies that the impaired retinol uptake rather than enzyme defects caused the diminished levels of retinyl esters present in tumor tissues (39). The significance of the lack of ability on the part of tumor cells to bring about retinol esterification is not known. However, it is possible that tumor cells may deprive themselves of an *in situ* retinol reservoir (i.e. retinyl esters) that can be used as a ready source of retinoid to promote cell differentiation and reduce cell proliferation.

Instead of esters or glucuronides of 9-*cis*-retinol, we detected several, possibly previously unknown metabolites of 9-*cis*-retinol in LRDHSN/MCF7 cells and media. The most abundant of these unknown compounds (P_{290}) appeared as early as 4 h after the addition of 9-*cis*-retinol to the media. The media levels of P_{290} continued to rise even after levels of 9-*cis*-retinal declined in the cells and media of LRDHSN/MCF7 cultures (data not

shown). This phenomenon may constitute a substrate-product relationship suggesting that P_{290} is formed from 9-*cis*-retinal. Alternatively, the accumulation of P_{290} in the media is also consistent with the notion that both P_{290} and 9-*cis*-retinal are formed from 9-*cis*-retinol but the subsequent metabolism of P_{290} is slower than that of 9-*cis*-retinal. However, since P_{290} was detected in the media and cells of cRDH transduced cells and not in empty vector transduced cells upon the treatment with 9-*cis*-retinol, we hypothesized that the compound is most likely a metabolite of 9-*cis*-retinal. To test this, we examined cells and media of LXS_N/MCF7 and LRDHS_N/MCF7 for their retinoid profiles following the treatment with 1 μ M 9-*cis*-retinal. As we predicted, both cell lines were able to produce P_{290} from 9-*cis*-retinal (Fig. 6) suggesting that P_{290} is indeed a direct metabolite of 9-*cis*-retinal. Currently, we do not know the chemical nature of P_{290} but this compound may contribute to the growth inhibitory effects observed for LRDHS_N/MCF7 cells upon treatment with 9-*cis*-retinol. Chen *et al.* reported that MCF7 cells can metabolize all-*trans*-retinol to all-*trans*-4-oxo-retinol after the cells were pretreated with all-*trans*-retinoic acid or the synthetic retinoid, 4-hydroxyretinamide (29). Interestingly, all-*trans*-4-oxo-retinol exerts a growth inhibitory effect on MCF7 cells. Based on their data, Chen *et al.* suggested that metabolites of 4-oxo-all-*trans*-retinol other than all-*trans*-retinoic acid may participate in growth inhibition of breast cancer cells. As far as we are aware, there are no data available concerning the possible conversion of 9-*cis*-retinol to 9-*cis*-4-oxo-retinol in mammary derived cells. We do not know whether 9-*cis*-4-oxo-retinol exists in either LRDHS_N/MCF7 or LXS_N/MCF7 cells.

Interestingly, following the treatment of LRDHS_N/MCF7 cells with 9-*cis*-retinal, these cells accumulated higher concentrations of 9-*cis*-retinal than did similarly treated LXS_N/MCF7 cells that were plated at similar cell densities (Fig. 7). In addition, LXS_N/MCF7 cells but not LRDHS_N/MCF7 cells accumulated some 9-*cis*-retinol upon treatment with 9-*cis*-retinal. These observations suggest that MCF7 cells express an enzyme(s), apart from cRDH, that is able to catalyze the reduction of 9-*cis*-retinal to 9-*cis*-

retinol. Since cRDH can catalyze either oxidation of 9-*cis*-retinol or reduction of 9-*cis*-retinal depending on the cellular redox state (NAD⁺/NADH) and the subcellular pH at the site of cRDH expression, this finding also suggests that cRDH catalyzes mainly 9-*cis*-retinol oxidation rather than 9-*cis*-retinal reduction in cultured MCF7 cells. This finding is in keeping with the calculated equilibrium constant for cRDH that indicates that at equilibrium, the 9-*cis*-retinal concentration should be 100 times greater than that of 9-*cis*-retinol provided sufficient oxidative potential (NAD⁺) (19).

The cellular mechanisms responsible for inhibiting *LRDHSN*/MCF7 cell proliferation upon treatment with 9-*cis*-retinol remain unclear. By light microscopy, we did not observe gross morphological changes such as cell shrinkage or blebbing of the membrane that would indicate apoptosis (40) for either *LXSN*/MCF7 or *LRDHSN*/MCF7 cells treated with 9-*cis*-retinol. However, more subtle changes in cellular morphology would not have been detected by this method. It is nevertheless clear that the introduction of cRDH activity into MCF7 cells followed by treatment of the cells with 9-*cis*-retinol has a marked effect on cell proliferation. These findings are in keeping with the notion that retinoid actions may depend on enzyme expression and other proteins involved in retinoid transport and metabolism in a tissue specific manner (41). In disease states such as cancer, changes in activity levels of enzymes or in expression levels of intracellular retinoid binding proteins may significantly influence cancer cell proliferation. Our data further demonstrated that retinol, without being converted to its "active metabolite", retinoic acid, can exert growth inhibitory effects on breast cancer cells. Since retinol can be better tolerated than high concentrations of retinoic acid, this raises the possibility of devising a two pronged approach of gene therapy to introduce an enzyme like cRDH followed by treatment with low levels of 9-*cis*-retinol as a possible chemotherapy regimen for combating breast cancer.

REFERENCES

1. Saari, J.C., *Retinoids in photosensitive systems*, in *The Retinoids : biology, chemistry, and medicine*, M.B. Sporn, A.B. Roberts, and D.S. Goodman, Editors. 1994, Raven Press: New York. p. 351-385.
2. Rosenthal, D., *et al.*, *Regulation of epithelial differentiation by retinoids*, in *Vitamin A in health and disease*, R. Blomhoff, Editor. 1994, M. Dekker: New York. p. 425-450.
3. Hofmann, C. and E. Gregor, *Retinoids in development*, in *The Retinoids : biology, chemistry, and medicine*, M.B. Sporn, A.B. Roberts, and D.S. Goodman, Editors. 1994, Raven Press: New York. p. 387-441.
4. Armstrong, R.B., *et al.*, *General and reproductive toxicology of retinoids*, in *The Retinoids : biology, chemistry, and medicine*, M.B. Sporn, A.B. Roberts, and D.S. Goodman, Editors. 1994, Raven Press: New York. p. 545-572.
5. Ross, A. and U. Hammerling, *Retinoids and the Immune System*, in *The Retinoids: Biology, Chemistry, and Medicine*, M. Sporn, A. Roberts, and D. Goodman, Editors. 1994, Raven Press: New York. p. 521-544.
6. Mangelsdorf, D.J., K. Umesono, and R.M. Evans, *The retinoid receptors*, in *The Retinoids: Biology, Chemistry, and Medicine*, M.B. Sporn, A.B. Roberts, and D.S. Goodman, Editors. 1994, Raven Press: New York. p. 319-350.
7. Glass, C.K., Some new twists in the regulation of gene expression by thyroid hormone and retinoic acid receptors. *J Endocrinol*, 1996. 150: p. 349-357.
8. Xu, L., C.K. Glass, and M.G. Rosenfeld, Coactivator and corepressor complexes in nuclear receptor function. *Curr Opin Genet Dev*, 1999. 9: p. 140-147.
9. McKenna, N.J., *et al.*, Nuclear receptor coactivators: multiple enzymes, multiple complexes, multiple functions. *J Steroid Biochem Mol Biol*, 1999. 69: p. 3-12.

10. Moon, R.C., R.G. Mehta, and K.V.N. Rao, *Retinoids and cancer in experimental animals*, in *The Retinoids : biology, chemistry, and medicine*, M.B. Sporn, A.B. Roberts, and D.S. Goodman, Editors. 1994, Raven Press: New York. p. 573-595.
11. Moon, R.C., R.G. Mehta, and C.J. Detrisac, Retinoids as chemopreventive agents for breast cancer. *Cancer Detect Prev*, 1992. 16: p. 73-79.
12. Gottardis, M.M., *et al.*, The efficacy of 9-cis retinoic acid in experimental models of cancer. *Breast Cancer Res Treat*, 1996. 38: p. 85-96.
13. Chai, X., Y. Zhai, and J.L. Napoli, cDNA cloning and characterization of a cis-retinol/3alpha-hydroxysterol short-chain dehydrogenase. *J Biol Chem*, 1997. 272: p. 33125-33131.
14. Su, J., *et al.*, cDNA cloning, tissue distribution, and substrate characteristics of a cis-Retinol/3alpha-hydroxysterol short-chain dehydrogenase isozyme. *J Biol Chem*, 1998. 273: p. 17910-17916.
15. Driessen, C.A., *et al.*, Cloning and expression of a cDNA encoding bovine retinal pigment epithelial 11-cis retinol dehydrogenase. *Invest Ophthalmol Vis Sci*, 1995. 36: p. 1988-1996.
16. Mertz, J.R., *et al.*, Identification and characterization of a stereospecific human enzyme that catalyzes 9-cis-retinol oxidation. A possible role in 9-cis- retinoic acid formation. *J Biol Chem*, 1997. 272: p. 11744-11749.
17. Romert, A., *et al.*, The identification of a 9-cis retinol dehydrogenase in the mouse embryo reveals a pathway for synthesis of 9-cis retinoic acid. *Proc Natl Acad Sci U S A*, 1998. 95: p. 4404-4409.
18. Simon, A., *et al.*, The retinal pigment epithelial-specific 11-cis retinol dehydrogenase belongs to the family of short chain alcohol dehydrogenases. *J Biol Chem*, 1995. 270: p. 1107-1112.
19. Paik, J., *et al.*, 9-cis-retinoids: Biosynthesis of 9-cis-retinoic acid. *Biochem*, In press.

20. Wang, J., *et al.*, Activity of human 11-cis-retinol dehydrogenase (Rdh5) with steroids and retinoids and expression of its mRNA in extra-ocular human tissue. *Biochem J*, 1999. 338: p. 23-27.
21. Lacroix, A. and M.E. Lippman, Binding of retinoids to human breast cancer cell lines and their effects on cell growth. *J Clin Invest*, 1980. 65: p. 586-591.
22. Marth, C., I. Mayer, and G. Daxenbichler, Effect of retinoic acid and 4-hydroxytamoxifen on human breast cancer cell lines. *Biochem Pharmacol*, 1984. 33: p. 2217-2221.
23. Marth, C., M. Widschwendter, and G. Daxenbichler, Mechanism of synergistic action of all-trans- or 9-cis-retinoic acid and interferons in breast cancer cells. *J Steroid Biochem Mol Biol*, 1993. 47: p. 123-126.
24. Soule, H.D., *et al.*, A human cell line from a pleural effusion derived from a breast carcinoma. *J Natl Cancer Inst*, 1973. 51: p. 1409-1416.
25. Van heusden, J., *et al.*, All-trans-retinoic acid metabolites significantly inhibit the proliferation of MCF-7 human breast cancer cells in vitro. *Br J Cancer*, 1998. 77: p. 26-32.
26. Zhao, Z., *et al.*, Effect of 9-cis-retinoic acid on growth and RXR expression in human breast cancer cells. *Exp Cell Res*, 1995. 219: p. 555-561.
27. Rubin, M., *et al.*, 9-Cis retinoic acid inhibits growth of breast cancer cells and down-regulates estrogen receptor RNA and protein. *Cancer Res*, 1994. 54: p. 6549-6556.
28. Takatsuka, J., N. Takahashi, and L.M. de Luca, Retinoic acid metabolism and inhibition of cell proliferation: an unexpected liaison. *Cancer Res*, 1996. 56: p. 675-678.
29. Chen, A.C., *et al.*, Human breast cancer cells and normal mammary epithelial cells: retinol metabolism and growth inhibition by the retinol metabolite 4-oxoretinol. *Cancer Res*, 1997. 57: p. 4642-4651.

30. Krekels, M.D., *et al.*, Induction of the oxidative catabolism of retinoid acid in MCF-7 cells. *Br J Cancer*, 1997. 75: p. 1098-1104.
31. Russell, W.C., C. Newman, and D.H. Williamson, A simple cytochemical technique for demonstration of DNA in cells infected with mycoplasmas and viruses. *Nature*, 1975. 253: p. 461-462.
32. Swisshelm, K., *et al.*, SEMP1, a senescence-associated cDNA isolated from human mammary epithelial cells, is a member of an epithelial membrane protein superfamily. *Gene*, 1999. 226: p. 285-295.
33. Napoli, J.L., Quantification of physiological levels of retinoic acid. *Methods Enzymol*, 1986. 123: p. 112-124.
34. Blaner, W.S., *et al.*, Studies on the in vivo transfer of retinoids from parenchymal to stellate cells in rat liver. *Eur J Biochem*, 1987. 164: p. 301-307.
35. Gamble, M.V., *et al.*, Biochemical properties, tissue expression and gene structure of a short chain dehydrogenase/reductase able to catalyze cis-retinol oxidation. *J. Lipid Res.*, 1999. 40: p. 2279-2292.
36. Kurlandsky, S.B., *et al.*, Plasma delivery of retinoic acid to tissues in the rat. *J Biol Chem*, 1995. 270: p. 17850-17857.
37. Resnicoff, M., *et al.*, Subpopulations of MCF7 cells separated by Percoll gradient centrifugation: a model to analyze the heterogeneity of human breast cancer. *Proc Natl Acad Sci U S A*, 1987. 84: p. 7295-7299.
38. Furr, H.C., A.B. Barua, and J.A. Olson, *Analytical methods*, in *The retinoids: Biology, Chemistry, and Medicine*, M.B. Sporn, A.B. Roberts, and D.S. Goodman, Editors. 1994, Raven press: New York. p. 179-209.
39. Bhat, P.V. and A. Lacroix, Metabolism of retinol and retinoic acid in N-methyl-N-nitrosourea- induced mammary carcinomas in rats. *Cancer Res*, 1989. 49: p. 139-144.

40. Rudin, C.M. and C.B. Thompson, *Apoptosis and Cancer*, in *The genetic basis of human cancer*, B. Vogelstein and K.W. Kinzler, Editors. 1998, McGraw-Hill: New York. p. 193-204.
41. Kuppumbatti, Y.S., *et al.*, Cellular retinol-binding protein expression and breast cancer [see comments]. *J Natl Cancer Inst*, 2000. 92: p. 475-80.

FIGURE LEGENDS

Figure 1. Retroviral vector structure and examination of cRDH transduction in MCF7 cells.

(A) The full length cRDH cDNA, including its poly-adenylation signal sequence, was cloned into LXS.N. LTR, long terminal repeat; SV, simian virus 40 promoter; Neo, neomycin phosphotransferase; pA, polyadenylation signal. The expected sizes for mRNA transcripts of cRDH directed by the retrovirus are ~2.6 and 4.5 kb. (B) Total RNA of clonal cells was fractionated and probed with cRDH cDNA sequence. All but *LRDHSN/MCF7* clone 6 express the transduced cRDH gene. (C) Whole cell homogenates of selected clones were examined for the expression of cRDH protein using a poly-clonal antibody. All of the *LRDHSN/MCF7* clones express expected 32 kDa protein.

Figure 2. (A) Growth kinetics of *LXS.N/MCF7* and *LRDHSN/MCF7* mass-culture cell lines treated with 9-*cis*-retinol. *LXS.N/MCF7* and *LRDHSN/MCF7* cells were plated at 100,000/T25 mm² flask and cultured in media containing either 1 μ M 9-*cis*-retinol or vehicle alone for 7 days. Cell numbers were determined at day 1, 3, 5, and 7 using a hemocytometer. Each data point represents the mean and standard deviation of cell numbers from 2 (9-*cis*-retinol treatment) or 4 flasks (ethanol treatment). Profound growth inhibition was detected in *LRDHSN/MCF7* cells treated with 9-*cis*-retinol compared to vehicle treatment (70%; \circ vs. \bullet). (B) Comparison of growth kinetics of *LRDHSN/MCF7* cells treated with either all-*trans*- or 9-*cis*-retinol. *LRDHSN/MCF7* mass-culture cells were plated at 100,000/T25 mm² flask and cultured in media supplemented with either 1 μ M all-*trans*-, 9-*cis*-retinol, or vehicle alone for 7 days. Cell numbers were counted at the predetermined time points. Each data point represents the mean and standard deviation of cell numbers from duplicate flasks. More profound growth inhibition occurred by 9-*cis*-retinol treatment compared to all-*trans*-retinol treatment (65% vs. 21%, in comparison to vehicle treatment).

Figure 3. Metabolism studies with clonal cell lines of transduced MCF7 cells.

LXSN/MCF7 (clone 6) and LRDHSN/MCF7 (clone 2) cells were plated at 100,000/T25 mm² flask and cultured in media containing 1 μ M 9-*cis*-retinol for 7 days. Media was changed every 48 hours, and (A) media and (B) cells were collected for retinoid analysis at the designated times. A representative finding from two independent experiments is shown. Levels of 9-*cis*-retinol in media of LRDHSN/MCF7 cells (A, \circ) were lower than that of LXSN/MCF7 cells (A, \square). In contrast, retinal was detected in the media of LRDHSN/MCF7 (A, \bullet), but not in that of LXSN/MCF7 (A, \blacksquare). Similar trend of retinol and retinal profiles was observed in cells (B), except that the concentrations of retinoids were 1-2 magnitude lower compared to the levels found in media. Each data point is the mean and standard deviation from duplicate flasks. Note the differences in scales of Y axis.

Figure 4. MCF7 cells lack the capability to oxidize 9-*cis*-retinal. Whole cell homogenates (100 μ g) of LRDHSN/MCF7 and LXSN/Hep G2 were examined for their capability to oxidize 9-*cis*-retinal. Cells were plated in T75 mm² flasks and cultured in complete tumor media (LRDHSN/MCF7) or 10% FBS supplemented α -MEM (Hep G2) to confluency. Production of 9-*cis*-retinoic acid during the 20 min incubation period was measured. Cell homogenates of LRDHSN/MCF7 produced insignificant amounts of 9-*cis*-retinoic acid compared to LXSN/Hep G2, indicating the lack of 9-*cis*-retinal oxidizing enzyme(s) in MCF7 cells.

Figure 5. Retinoid profiles from media of LRDHSN/MCF7 cells at 8 h after the treatment with 1 μ M 9-*cis*-retinol. LXSN/MCF7 and LRDHSN/MCF7 cells were plated at 500,000/p60 mm² plate and cultured in media containing 1 μ M 9-*cis*-retinol for 24 h. Cells and media were collected at predetermined time points and analyzed for retinoids (both mass and radioactivity). (A) Chromatograms at two wave lengths are shown (300 nm and

325 nm). (B) The spectrum of an unknown compound (→) is presented compared to that of 9-*cis*-retinol and 9-*cis*-retinal.

Figure 6. An unknown compound (unknown 1) is likely a metabolite of 9-*cis*-retinal. L_{XSN}/MCF7 and L_{RDHSN}/MCF7 mass-culture cells were plated at 500,000/p60 mm² plate and cultured in media containing 1 μM 9-*cis*-retinal for 24 h. Cells and media were collected and analyzed for the unknown 1. The unknown 1 was detected in both cells (A) and media (B) of the two cell lines. Because the identity of the compound is not known, its concentrations are depicted as the peak area under the curve (AUC) at 300 nm. Each data point is the mean and standard deviation of results from duplicate plates.

Figure 7. 9-*cis*-retinoid profiles in cells and media of L_{XSN}/MCF7 and L_{RDHSN}/MCF7 treated with 1 μM 9-*cis*-retinal. L_{XSN}/MCF7 and L_{RDHSN}/MCF7 mass-culture cells were plated at 500,000/p60 mm² plate and cultured in media containing 1 μM 9-*cis*-retinal for 24 h. (A) Cells and (B) media were collected and extracted for retinoid profiles. L_{XSN}/MCF7 cells appeared to rapidly reduce 9-*cis*-retinal to 9-*cis*-retinol, since 9-*cis*-retinal in media (B, ■) diminished quickly, while levels of 9-*cis*-retinol in cells (A, □) and media (B, □) rise throughout the experimental period. In contrast, only a small amount of 9-*cis*-retinol was detected in L_{RDHSN}/MCF7 cells and media (○), likely due to high activity of cRDH in these cells. Each data point is the mean and standard deviation of results from duplicate plates.

Figure 8. Growth kinetics of transduced MCF7 cells treated with 9-*cis*-retinal. L_{XSN}/MCF7 and L_{RDHSN}/MCF7 mass-culture cells were plated at 100,000/T25 mm² flask and cultured in media containing either 0.1 μM or 1 μM 9-*cis*-retinal for 7 days. Growth inhibition was observed in both cell lines at 1 μM 9-*cis*-retinal, while L_{RDHSN}/MCF7 cells exhibited enhanced growth repression compared to L_{XSN}/MCF7

cells (46% vs. 30%; in comparison to 0.1 μM 9-*cis*-retinal treated cells). Vehicle treatment was not included in this experiment, since growth kinetics of cells with 0.1 μM 9-*cis*-retinal treatment did not differ from vehicle treated cells in preliminary studies.

A.

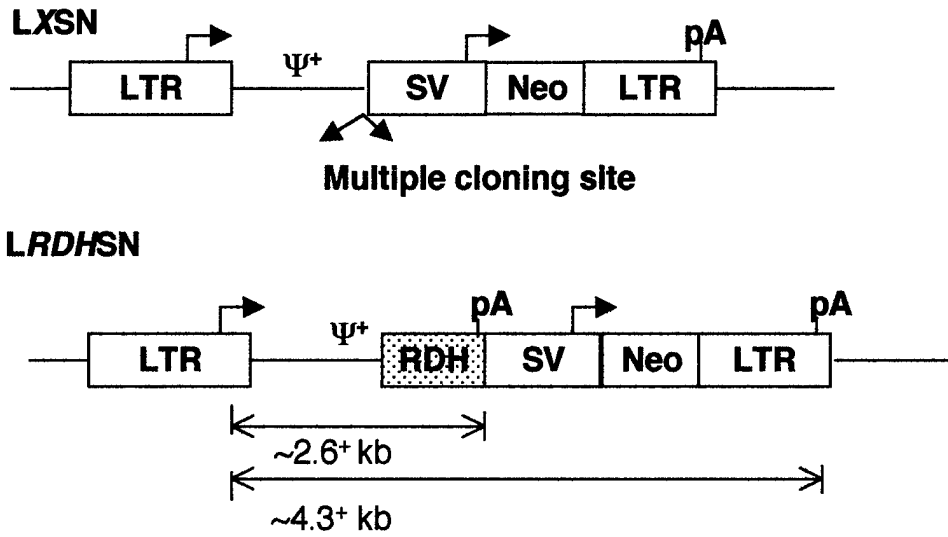

B.

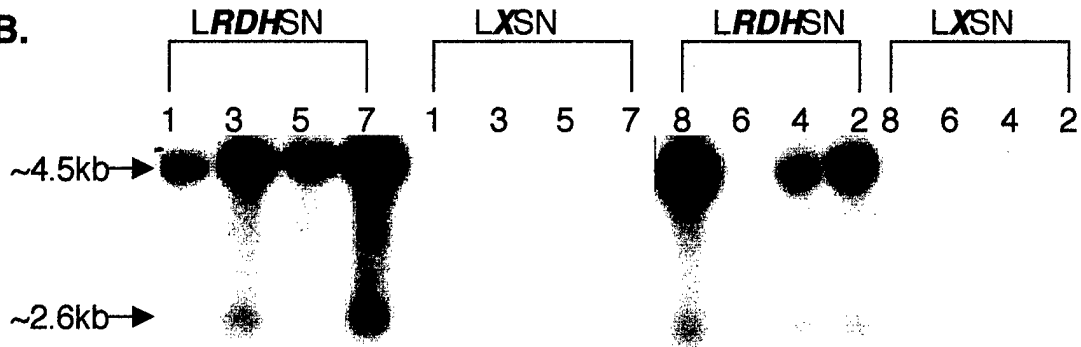

C.

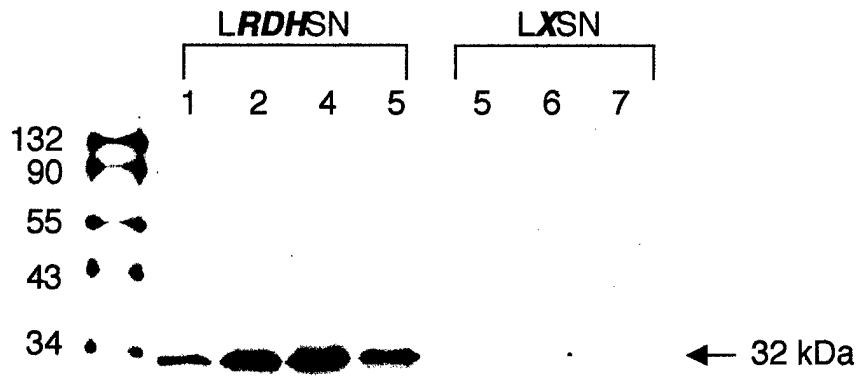

A.

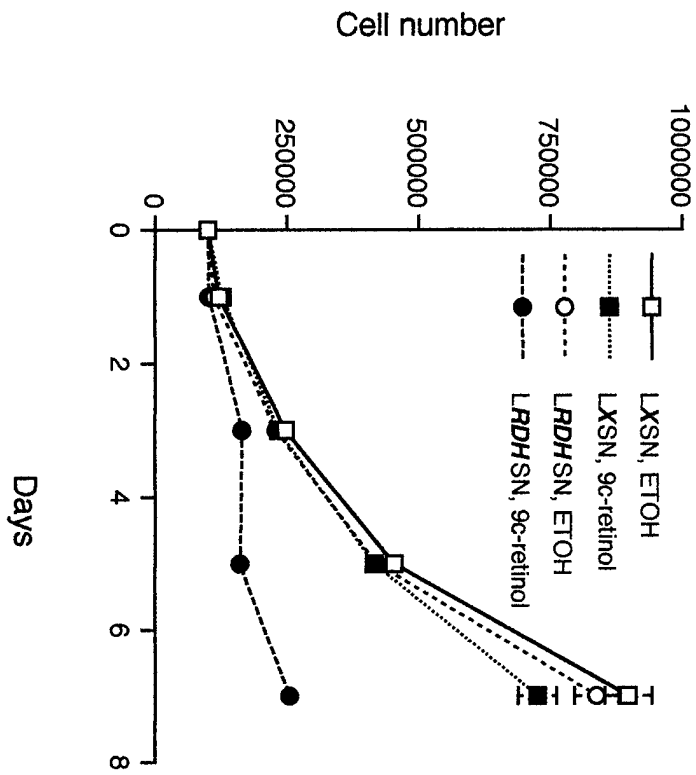

B.

