

**FINAL REPORT
DECEMBER 2000**

REPORT NO. 99-13



**JOINT STANDOFF WEAPON (JSOW)
IN CNU-575/E CONTAINER
TRANSPORTABILITY TEST, TP-94-01,
"TRANSPORTABILITY TESTING PROCEDURES"**

Prepared for:
Naval Surface Warfare Center
Indian Head Division, Detachment Earle
ATTN: Naval PHST Center, Code 711KT, Bldg. C-54
201 Highway 34 South
Colts Neck, NJ 07722-5023

Distribution Unlimited

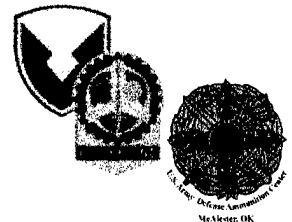

**VALIDATION ENGINEERING DIVISION
MCALESTER, OKLAHOMA 74501-9053**

20010328 069

AVAILABILITY NOTICE

A copy of this report will be furnished each attendee on automatic distribution. Additional copies or authority for reprinting may be obtained by written request from:

Director
U.S. Army Defense Ammunition Center
ATTN: SMAAC-DEV
1 C Tree Road, Bldg. 35
McAlester, OK 74501-9053

Reports may also be downloaded or viewed in PDF format from our web site at:

<http://www.dac.army.mil/DEV/TestReports>

DISTRIBUTION INSTRUCTIONS

Destroy this report when no longer needed. Do not return.

Citation of trade names in this report does not constitute an official endorsement.

The information contained herein will not be used for advertising purposes.

**REPORT NO. 99-13
JOINT STANDOFF WEAPON (JSOW)
IN CNU-575/E CONTAINER TRANSPORTABILITY TEST
TP-94-01, "TRANSPORTABILITY TESTING PROCEDURES"**

July 2000

ABSTRACT

The U.S. Army Defense Ammunition Center (DAC), Validation Engineering Division (SMAAC-DEV), was tasked by the Naval Surface Warfare Center, Indian Head Division, Detachment Earle, PHS&T Center, to test outloading procedures and conduct transportability testing for the Joint Standoff Weapon (JSOW) in a CNU-575/E Container. Transportability testing included rail impact testing and Shipboard Transportation Simulator (STS) testing. The rail impact testing was conducted with the JSOW container loaded inside a double door boxcar and inside an end opening ISO freight container. The STS testing was conducted with the JSOW container loaded inside an ISO freight container. The tests were performed in accordance with Test Method 1 - Rail Impact Test, and Test Method 4 - Shipboard Transportation Simulator, as defined in TP-94-01, "Transportability Testing Procedures." Loading and unloading of the JSOW containers to and from the double door boxcar and the ISO freight container was difficult due to the lack of material handling interface points on the container. Following completion of testing the containers were examined and no damage was found on the containers. As a result of the performance of the Joint Standoff Weapon (JSOW) in a CNU-575/E Container during testing, the JSOW container is recommended for transport within a double door boxcar and inside an ISO container when blocked and braced as tested.

Prepared by:

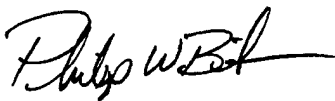

PHILIP W. BARICKMAN
Lead Validation Engineer

Reviewed by:



JERRY W. BEAVER
Chief, Validation Engineering Division

U.S. ARMY DEFENSE AMMUNITION CENTER

VALIDATION ENGINEERING DIVISION
MCALESTER, OK 74501-9053

REPORT NO. 99-13

**JOINT STANDOFF WEAPON (JSOW) IN A CNU-575/E CONTAINER
TRANSPORTABILITY TEST,
TP-94-01, "TRANSPORTABILITY TESTING PROCEDURES"**

TABLE OF CONTENTS

PART	PAGE NO.
1. INTRODUCTION.....	1-1
A. BACKGROUND.....	1-1
B. AUTHORITY.....	1-1
C. OBJECTIVE	1-1
D. CONCLUSION	1-1
E. RECOMMENDATION	1-2
2. ATTENDEES	2-1
3. TEST PROCEDURES	3-1
A. TEST PREPARATION	3-1
B. RAIL IMPACT TEST METHOD.....	3-1
C. SHIPBOARD TRANSPORTATION SIMULATOR TEST METHOD	3-3
4. TEST EQUIPMENT/RESULTS.....	4-1
5. DRAWINGS	5-1

INTRODUCTION

A. BACKGROUND. The U.S. Army Defense Ammunition Center (DAC), Validation Engineering Division (SMAAC-DEV), was tasked by Naval Surface Warfare Center, Indian Head Division, Detachment Earle, Packaging, Handling, Storage and Transportation (PHS&T) Center, to test outloading procedures and conduct transportability testing for the Joint Standoff Weapon (JSOW) in a CNU-575/E Container. Transportability testing included rail impact testing and Shipboard Transportation Simulator (STS) testing. The testing was conducted in accordance with the criteria specified in TP-94-01, "Transportability Testing Procedures," dated July 1994.

B. AUTHORITY. This test was conducted IAW mission responsibilities delegated by the U.S. Army Operations and Support Command, Rock Island, IL. Reference is made to the following:

1. Change 6, AR 740-1, 18 August 1976, Storage and Supply Activity Operation.

2. IOC-R, 10-23, Mission and Major Functions of USADAC, 7 January 1998.

C. OBJECTIVE. The objective of the tests was to evaluate outloading procedures and to conduct transportability testing for the JSOW in a CNU-575/E Container when transported inside a boxcar and inside an ISO container.

D. CONCLUSION. The JSOW in a CNU-575/E Container was evaluated in accordance with TP 94-01, "Transportability Testing Procedures." Following the completion of each rail impact test the containers were examined for damage and movement. The blocking and bracing was also examined for damage. Final inspection following completion of testing with the JSOW loaded in the double

door boxcar and in the ISO container did not reveal any damage to the JSOW container or the blocking and bracing. Therefore, the blocking and bracing procedures as tested were adequate.

The loading and unloading of the JSOW into the double door boxcar and the ISO container was a very difficult task. In order to load the boxcar and container, the JSOW containers had to be lifted at one end and slid into place with the forklift. The JSOW containers do not have any provisions on the ends to safely allow handling with a forklift in this manner. The containers also do not have any provisions on the underneath side to allow them to safely be slid along the floor or on top of each other.

E. RECOMMENDATION. As a result of the performance of the JSOW in a CNU-575/E Container during testing, the JSOW container is recommended for transport within a double door boxcar and inside an ISO container when blocked and braced as tested.

Due to the difficulties in loading and unloading the JSOW containers into the double door boxcar and the ISO container, it is recommended that an interface kit be developed which will enable the containers to be picked up at each end and allow them to be slid.

PART 2 - ATTENDEES

DATES PERFORMED: 21 March – 4 April 2000

ATTENDEE

MAILING ADDRESS

Philip W. Barickman
General Engineer
DSN 956-8992
(918) 420-8992

Director
U.S. Army Defense Ammunition Center
ATTN: SMAAC-DEV
1 C Tree Road, Bldg. 35
McAlester, OK 74501-9053

Laura A. Fieffer
General Engineer
DSN 956-8072
(918) 420-8072

Director
U.S. Army Defense Ammunition Center
ATTN: SMAAC-DET
1 C Tree Road, Bldg. 35
McAlester, OK 74501-9053

Richard Eaves
(732) 866-2906

Naval Surface Warfare Center
Indian Head Division–Detachment Earle
ATTN: Naval PHST Center,
Code 1KT, Bldg. C-54
201 Highway 34 South
Colts Neck, NJ 07722-5023

SMsgT Johnny A. Lamb
DSN 872-9163 Ext 618

Det 2 AFOTEC/AA (AF OperationalTest)
Eglin AFB, FL 32542

MsgT Ron Ford
DSN: 574-4030

HA ACC/XRWC (ACC Acquisitions)
Langley AFB, VA 23665

Major John Lee
DSN: 872-5780

AAC/YHJ (JSOW SPO)
Eglin AFB, FL 32542

PART 3 - TEST PROCEDURES

The test procedures outlined in this section were extracted from TP-94-01, "Transportability Testing Procedures," July 1994, for validating tactical vehicles and outloading procedures used for shipping munitions by intermodal freight containers, commercial or tactical truck or trailer, or railcar. The rail impact test procedures are described below.

A. TEST PREPARATION: The test load was prepared using the blocking and bracing procedures proposed for use with munitions (see Part 5 for procedures). The first rail impact test was conducted with the JSOW in a CNU-575/E Container test load in the double door boxcar. The second rail impact test was conducted with the JSOW in a CNU-575/E Container test load in an ISO container. Inert (non-explosive) items were used to build the load. The weight and physical characteristics (weights, physical dimensions, center of gravity, etc.) of the JSOW in a CNU-575/E Container test load in an ISO container were identical to live (explosive) ammunition. Inert (non-explosive) items were used as ballast to equate the payload weight to that of a fully loaded boxcar of JSOW in a CNU-575/E Container.

B. RAIL IMPACT TEST METHOD. The JSOW in CNU-575/E Containers were loaded and secured in the double door boxcar and in an ISO container on a flatcar with conventional friction draft gear. Equipment needed to perform the test included the specimen (hammer) car, four (4) empty railroad cars connected together to serve as the anvil, and a railroad locomotive. The anvil cars were positioned on a level section of track with air and hand brakes set and with draft gears compressed. The locomotive unit pushed the specimen car toward the anvil at a predetermined speed, then disconnected from the specimen car approximately fifty (50) yards away from the anvil cars allowing the specimen car to roll freely along the track until it struck the anvil. This constituted an impact. Impacting was accomplished at speeds of 4, 6, and 8.1 mph in one direction, and

at a speed of 8.1 mph in the reverse direction. The 4 and 6 mph impact speeds were approximate; the 8.1 mph is a minimum. Impact speeds were determined by using an electronic counter to measure the time for the specimen car to traverse an 11-foot distance immediately prior to contact with the anvil cars (see Figure 1).

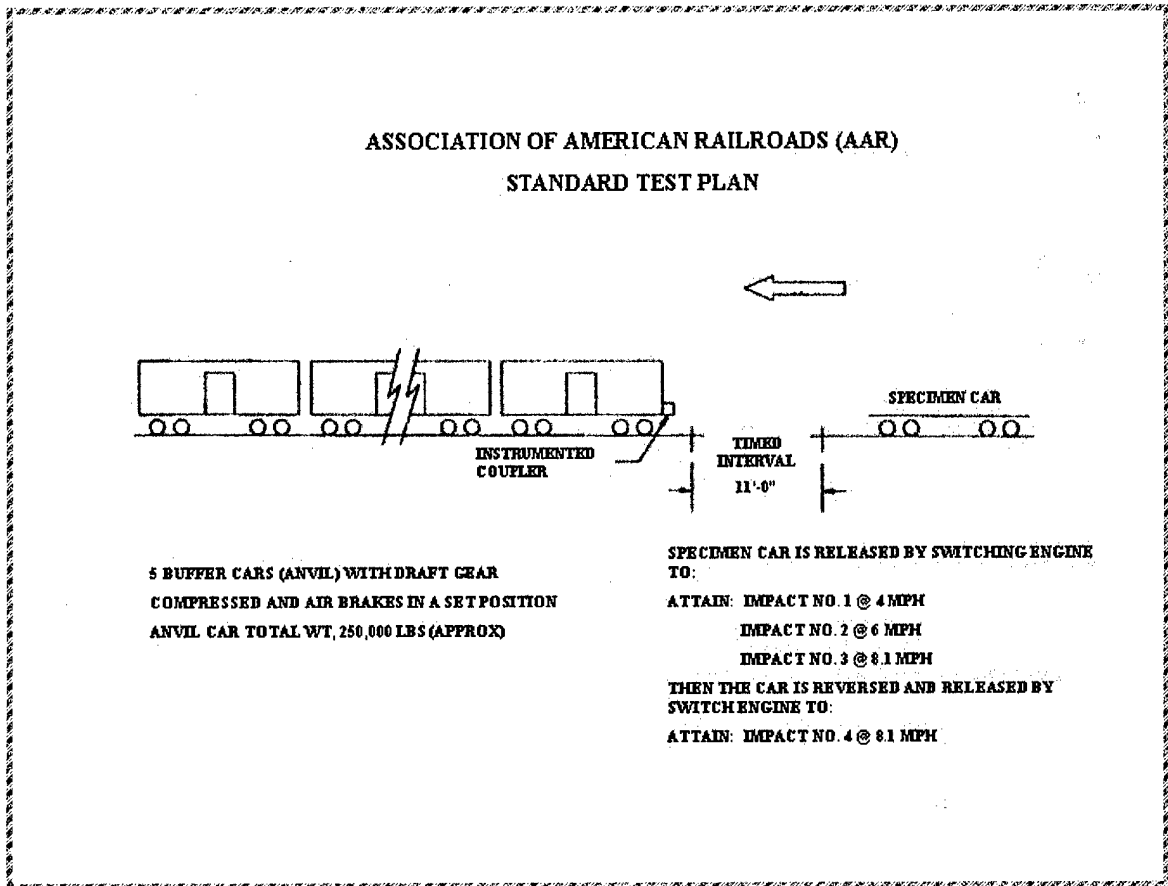

Figure 1.

C. SHIPBOARD TRANSPORTATION SIMULATOR (STS) TEST METHOD.

The ISO container was positioned onto the STS and securely locked in place using the cam locks at each corner. The STS was started oscillating at an angle of 30 degrees plus or minus 2 degrees, either side of center and at a frequency of 2 cycles-per-minute (30 seconds plus or minus 2 seconds total roll period). This frequency was observed for apparent defects that could cause a safety hazard. The frequency of oscillation was then increased to 4 cycles-per-minute (15 seconds plus or minus one second per roll period) and the apparatus operated for 2 hours. After inspection, the load showed no impending failure, the frequency of oscillation was further increased to 5 cycles-per-minute (12 seconds plus or minus one-second cycle time), and the apparatus operated for 4 hours. No change or adjustments to the load or load restraints were permitted at any time during the test. After once being set in place, the test load (specimen) was not removed from the apparatus until the test had been completed.

PART 4 - TEST EQUIPMENT/RESULTS

A. RAIL IMPACT DATA

Test Number 1

Date: 21 March 2000

Specimen Load: Joint Standoff Weapon (JSOW) in a CNU-575/E
Container in the double door boxcar.

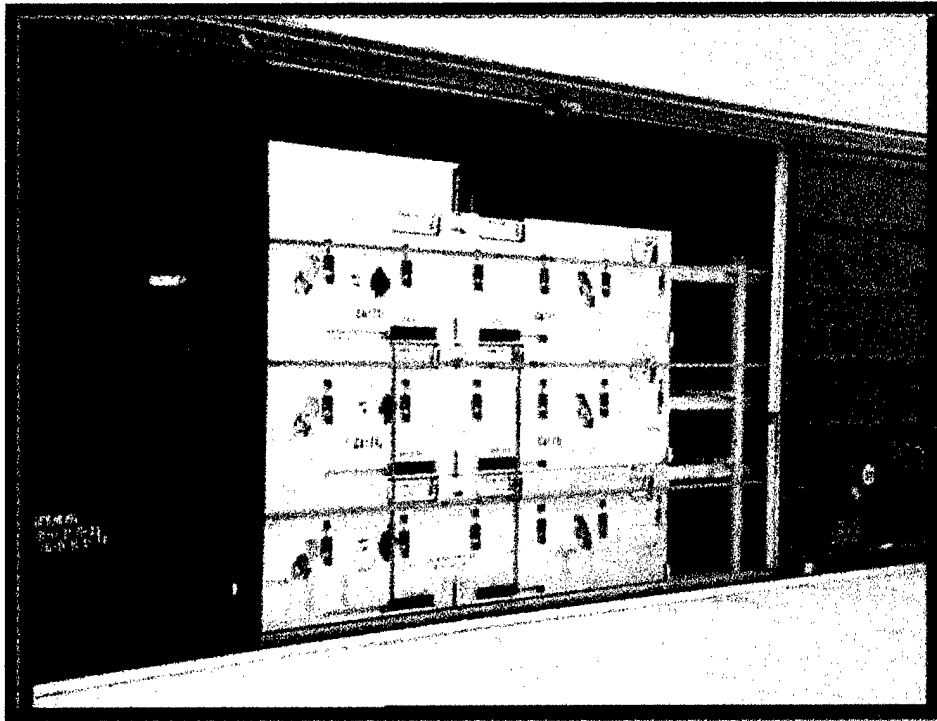

Photo 1. Rail impact testing of JSOW container in the double door boxcar.

DESCRIPTION	WEIGHT
Boxcar Number: WP 38715	62,000 lbs.
JSOW Containers Wt.	13,302 lbs.
Ballast:	
CNU-305 Containers?	53,210 lbs.
Total Specimen Wt.	128,512 lbs.
Buffer Car (four cars)	250,000 lbs.

Impact Number	Velocity (mph)	Remarks
1	4.17	None
2	6.19	Ballast dunnage moved
3	8.15	Ballast dunnage broke.
4	8.33	None

1. Results:

a. The CNU-305 containers moved during testing due to breakage of the struts of the blocking and bracing. Following Impact Number 3, the determination was made that the struts being used on the CNU-305 containers had been damaged to such an extent that replacement was required prior to Impact Number 4 due to safety reasons. The CNU-305 containers were being used as ballast and repair of the ballast dunnage did not effect the evaluation of the blocking and bracing procedures for the JSOW containers.

b. Following each impact, the JSOW containers were inspected and no damage was found.

2. **Loading**: The JSOW containers were placed into the boxcar and loaded onto each other to get a three-high stack at the doorway of the boxcar. Once the three-high stack was completed, the MK-45 (see Photo 2) handlers were used to lift the three-high stack and roll them as close as possible to the boxcar corner. This exceeded the design rating (3,000 pounds-per-handler) of the MK-45 handlers. A forklift was then used to push and side-shift the containers tightly into the corner of the boxcar. The center stack of JSOW containers was assembled by placing each of the containers through the doorway of the boxcar. The JSOW containers were then steel banded together and side shifted into place.



Photo 2. MK-45 handlers.

3. **Unloading:** Removal of the JSOW containers from the boxcar required that they be slid out of position using a strap attached to the slinging provisions of the container to slide them until they could be picked up using the MK-45 or a forklift truck.

Test Number 2

Date: 22 March 2000

Specimen Load: JSOW in CNU-575/E Containers in an end opening ISO Container on a flatcar.



Photo 3. Rail impact testing of JSOW containers in an ISO container.

Description	Weight
Flatcar Number: DODX48797	62,700 lbs.
JSOW Containers and ISO Container	13,840 lbs.
Ballast: (on flatcar)	
3 containers with inert munitions (105MM, 155MM, and small arms)	121,110 lbs.
Total Specimen Wt.	197,650 lbs.
Buffer Car (4 cars)	250,000 lbs.

Impact Number	Velocity (mph)	Remarks
1	4.01	None
2	6.14	None
3	8.62	None
4	8.43	JSOW containers moved 0.25 inches

1. **Results:** Following each impact, the JSOW Containers were inspected and no damage was found.

2. **Loading:** The JSOW containers were picked up using the forklift pockets and side shifting one end into the doorway of the container. On the

roadside of the container, the MK-45 handlers were used to get the two-high stack of JSOW containers as close to final position as possible. On the curbside of the container, the forklift tines were placed under the end of the JSOW container and the stack was placed as close to the final position as possible. Final positioning on each side of the container was done by placing a protector board at the base of the JSOW container and using a forklift to slide and push the container into position.

3. Unloading: On the roadside of the ISO container the MK-45 handler was used to get the JSOW containers away from the wall (see Photo 4). On the curbside, the tines of the forklift were placed under the MK-45 lifting bracket and the stack was lifted and side shifted away from the container wall (see Photo 5). The forklift tines were placed under the JSOW container and each stack was slid out of the container until the forklift pockets could be engaged (see Photos 6 & 7). Also, a strap was wrapped around the mast of the forklift and hooked into the JSOW container lifting rings to ensure that the JSOW containers would not slide off of the tines of the forklift.



Photo 4. Side shift of JSOW containers using the MK-45 handlers.



Photo 5. Side shift of JSOW containers using the forklift truck.



Photo 6. Sliding of the JSOW containers.

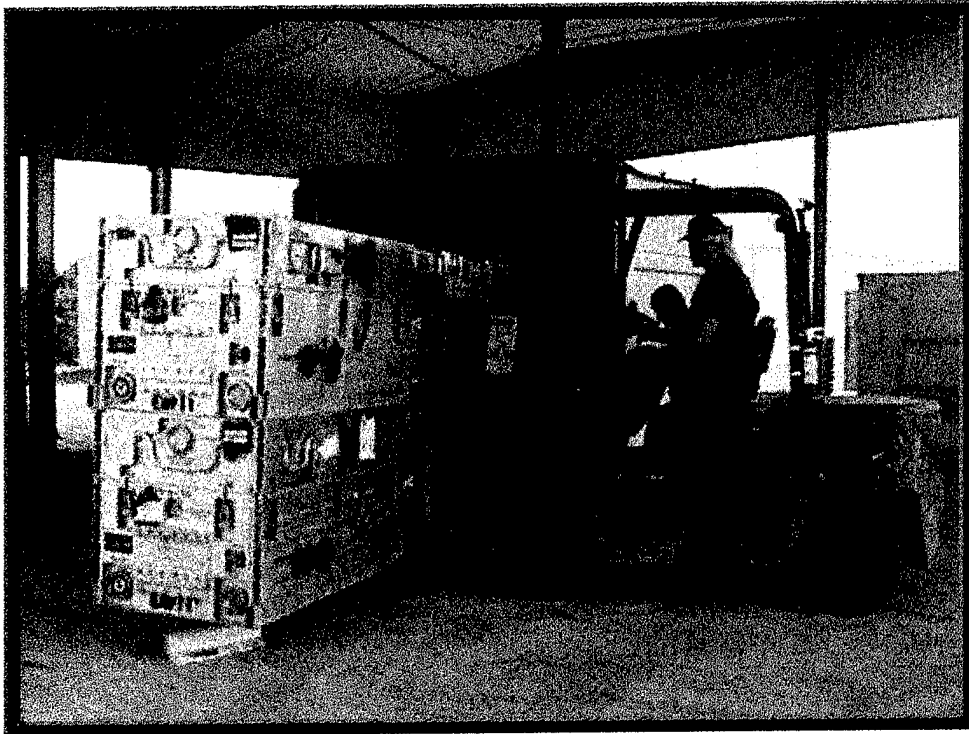

Photo 7. Removal of JSOW containers from the ISO container.

B. Shipboard Transportation Simulator (STS) Testing

Date: 4 April 2000

Specimen Load: JSOW in CNU-575/E Containers in an end opening ISO container.

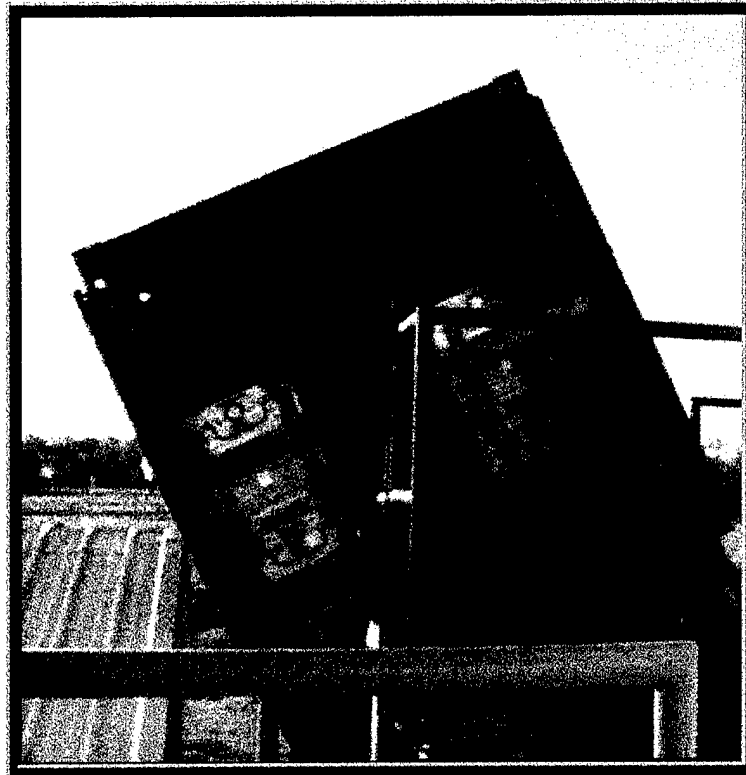

Photo 8. Shipboard Transportation Simulator Testing of JSOW containers.

DESCRIPTION	WEIGHT
JSOW IN CNU 575/E Container	8,880 lbs
Container Weight	4,920 lbs
Total Weight	13,800 lbs

DESCRIPTION	DURATION	REMARKS
STS @ 4 cycles-per-minute	2 hours	None
STS @ 5 cyles-per-minute	4 hours	None

Result: No damage or movement of the JSOW containers was observed.

PART 5 – DRAWINGS

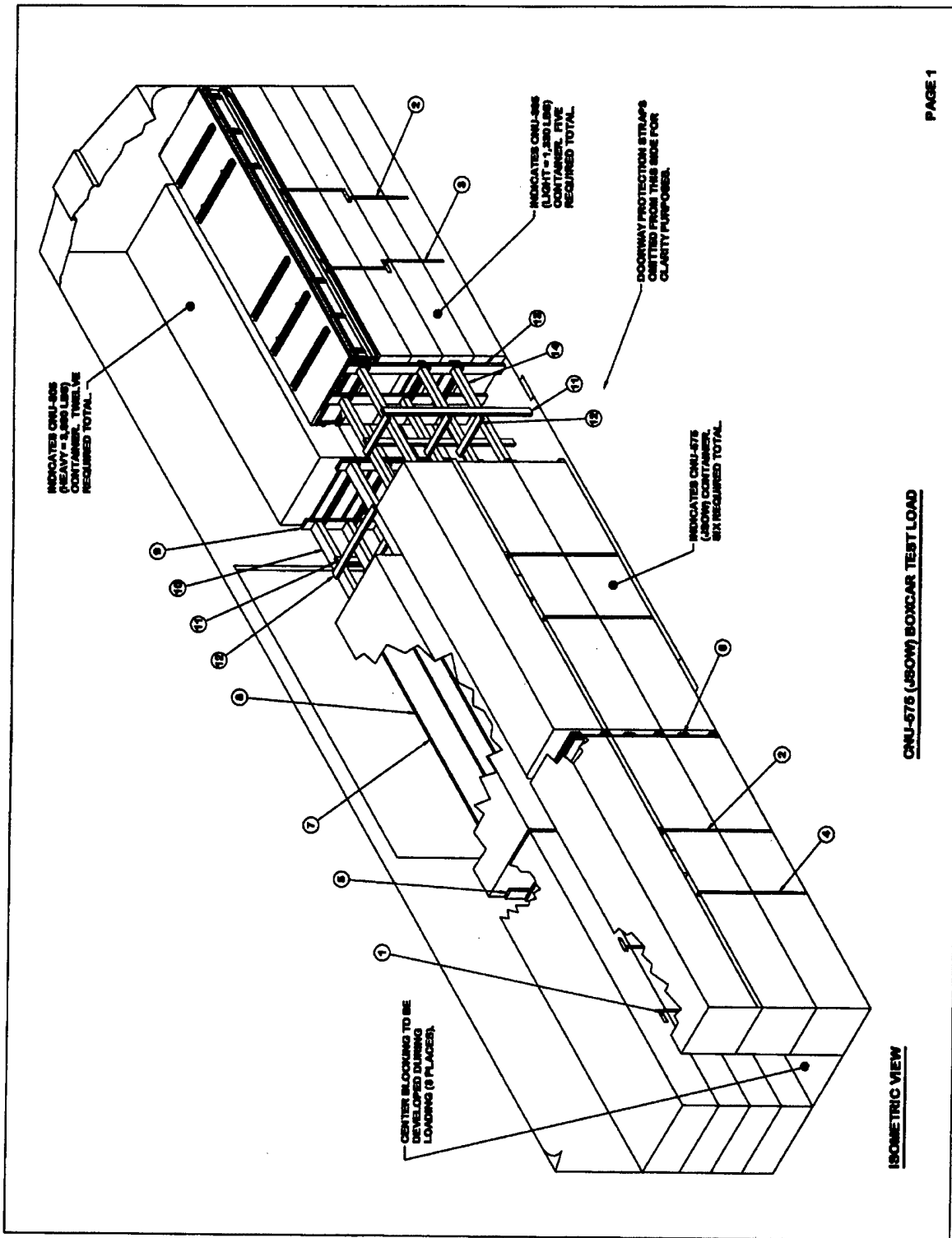

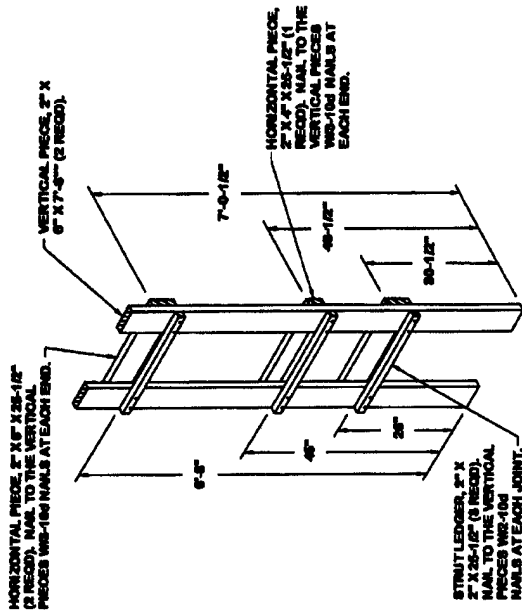

CENTER GATE A

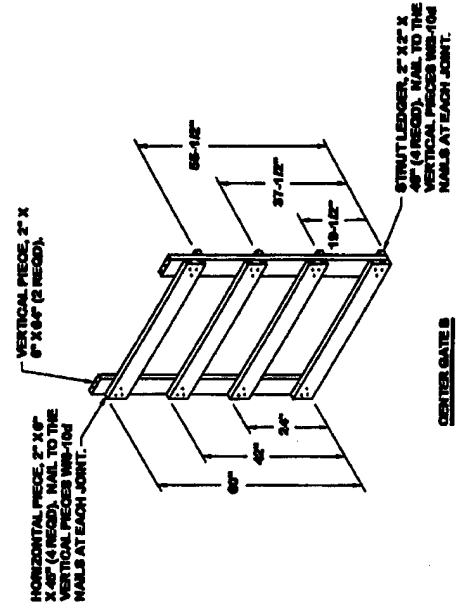

CENTER GATE B

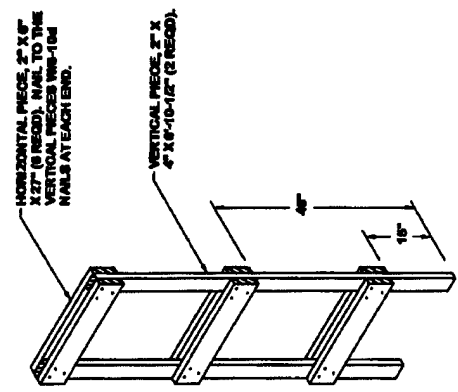

SEPARATOR GATE A

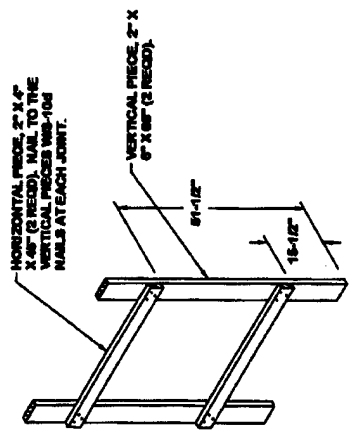

SEPARATOR GATE B

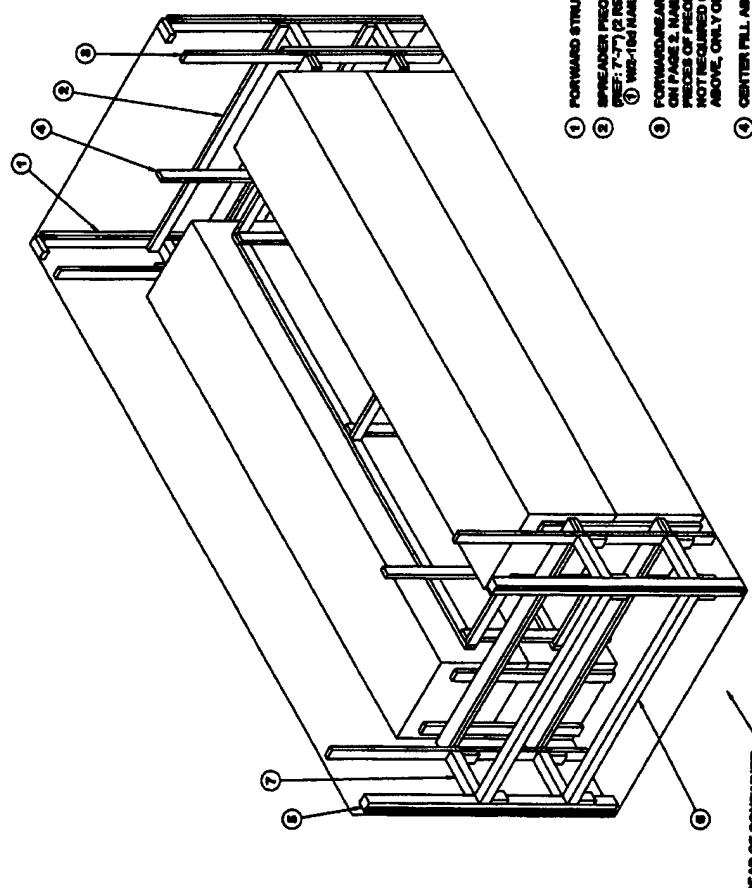

REAR OF CONTAINER.

ISOMETRIC VIEW

KEY NUMBERS

- ① FORWARD STRUT ASSEMBLY (2 REQD). SEE THE DETAIL ON PAGE 2.
- ② BRACED PIECE, 2" X 4" BY INSIDE CONTAINER WIDTH MINUS 1" (SEE: 7-17) (2 REQD). NAIL THE BUFFER PIECES OF PIECE MARKED ① W/8-15# NAILS AT EACH END.
- ③ FORWARD/REAR BLOCKING ASSEMBLY (2 REQD). SEE THE DETAIL ON PAGE 2. NAIL THROUGH THE BUFFER PIECES INTO THE VERTICAL PIECES OF PIECE MARKED ① W/8-15# NAILS. NOTE: STRUT LEADERS NOT REQUIRED ON THE FORWARD BLOCKING ASSEMBLY DEPICTED ABOVE, ONLY ON THE REAR BLOCKING ASSEMBLY.
- ④ CENTER PILL ASSEMBLY (1 REQD). SEE THE DETAIL ON PAGE 3.
- ⑤ DOOR POST VERTICAL (2 REQD). SEE THE DETAIL ON PAGE 3.
- ⑥ DOOR SPANNER, 4" X 4" MATERIAL, CUT TO A LENGTH THAT WILL PROVIDE FOR A DRIVE FIT (REF: 7-1-8M) (2 REQD). TOSHAL TO THE DOOR POST VERTICAL W/8-15# NAILS AT EACH END.
- ⑦ STRUT, 4" X 4" BY CUT TO FIT (REF: 17-1-8M) (2 REQD). TOSHAL TO THE DOOR POST VERTICAL AND THE REAR BLOCKING ASSEMBLY W/8-15# NAILS AT EACH END.

BUFFER PIECE, 2" X 4" BY INSIDE CONTAINER HEIGHT MINUS 1" (REF. 7-7) (DOUBLED) (1 REQD). NAIL TO THE STRUTS W8-128 NAILS AT EACH JOINT.

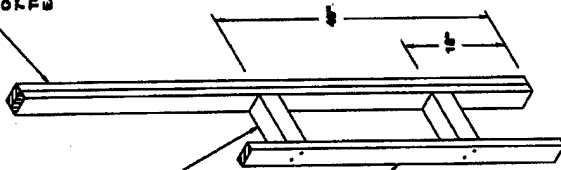

STRUT, 2" X 4" X 16" (2 REQD).

VERTICAL PIECE, 2" X 4" X 8" (1 REQD). NAIL TO THE STRUTS W8-128 NAILS AT EACH JOINT.

FORWARD STRUT ASSEMBLY

BUFFER PIECE, 2" X 4" BY INSIDE CONTAINER HEIGHT MINUS 1" (REF. 7-6) (DOUBLED) (2 REQD). NAIL TO THE BEAM ASSEMBLY W8-164 NAILS AT EACH JOINT.

VERTICAL PIECE, 2" X 4" X 8" (1 REQD). NAIL TO THE BEAM ASSEMBLY W8-164 NAILS AT EACH JOINT.

BEAM ASSEMBLY, 2" X 4" BY INSIDE CONTAINER WIDTH MINUS 1" (REF. 7-7) (DOUBLED) (2 REQD). LAMINATE THE FIRST PIECE TO THE SECOND W8-164 NAILS.

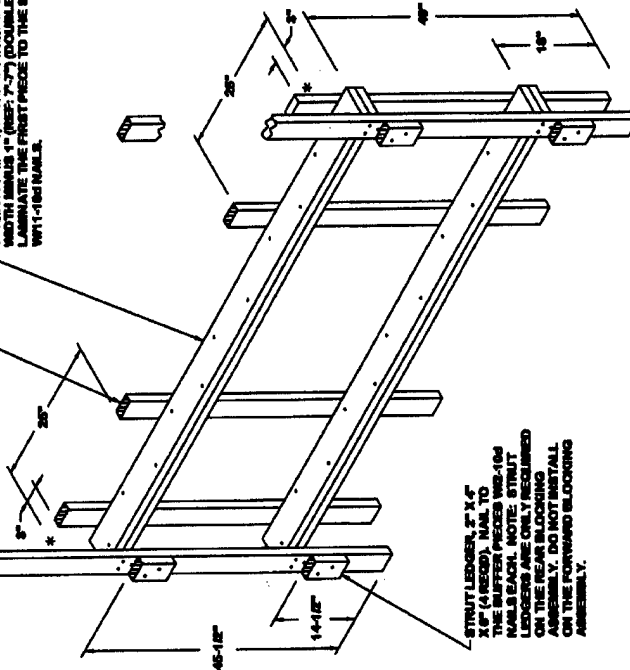

STRUT LEISER, 2" X 4" X 8" (1 REQD). NAIL TO THE BUFFER PIECE W8-164 NAILS EACH. NOTE: STRUT LEISERS ARE ONLY USED ON THE FORWARD BLOCKING ASSEMBLY. DO NOT INSTALL ON THE FORWARD BLOCKING ASSEMBLY.

FORWARD/REAR BLOCKING ASSEMBLY

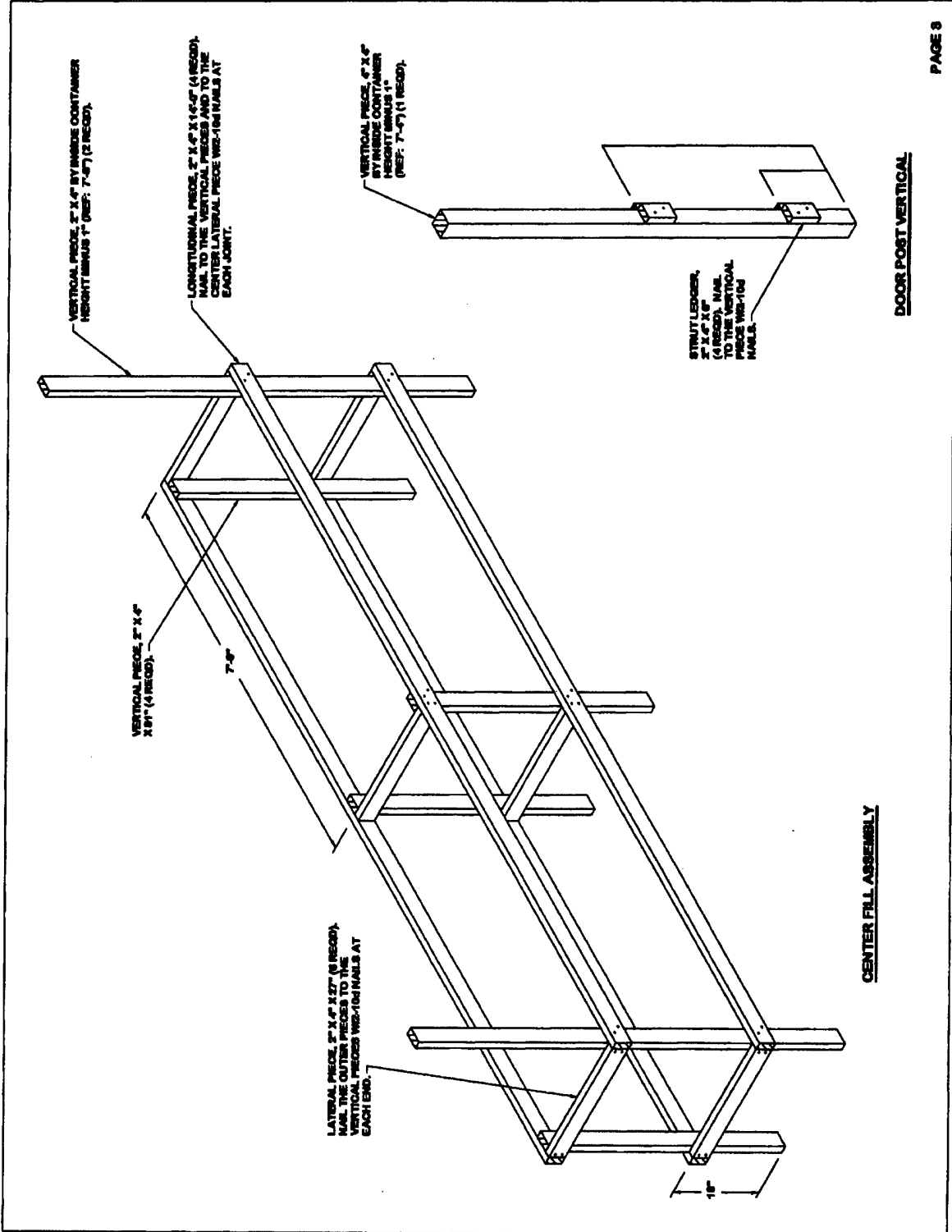

DOOR POST VERTICAL

CENTER FILL ASSEMBLY