



# Water as a Three-Dimensional Fire-Extinguishing Agent

by Philip J. Peregino II, Anthony E. Finnerty,  
Robert McGill, Lawrence J. Vande Kieft,  
and Dawnn Saunders

ARL-TR-2357

October 2000

Approved for public release; distribution is unlimited.

20010402 113

The findings in this report are not to be construed as an official Department of the Army position unless so designated by other authorized documents.

Citation of manufacturer's or trade names does not constitute an official endorsement or approval of the use thereof.

Destroy this report when it is no longer needed. Do not return it to the originator.

# Army Research Laboratory

Aberdeen Proving Ground, MD 21005-5066

---

---

ARL-TR-2357

October 2000

## Water as a Three-Dimensional Fire-Extinguishing Agent

Philip J. Peregino II, Anthony E. Finnerty, and Robert McGill  
Weapons and Materials Research Directorate, ARL

Lawrence J. Vande Kieft  
Faith Farm

Dawnn Saunders  
DSI Corporation

---

## Abstract

---

It is generally believed that, because of its ability to absorb large quantities of heat, a mist of water droplets would be an excellent fire-extinguishing agent. A device has been constructed to disseminate a high volume of fine droplets of a liquid agent (water) in such a way as to make the liquid droplets permeate an enclosure. This device is capable of dispersing a water mist throughout a volume. Thus, the water mist can act as a three-dimensional agent, much like gaseous agents.

The device consists of two equally pressurized cylinders, fast-acting solenoid valves, a mixing chamber, and the necessary hardware to complete the system. One cylinder contains a vaporizable liquid, such as CO<sub>2</sub>, and the second contains a liquid agent, such as water or water-based solution pressurized with CO<sub>2</sub> or nitrogen. Upon activating the solenoid valves, two liquid streams (CO<sub>2</sub> and water or water-based solution) are directed into a mixing chamber, such as a vortex mixer. The two streams are blended intimately in the chamber. Upon exiting the mixer into a nozzle, the vaporizable liquid flash evaporates and expands throughout the volume of an enclosure. This expanding gas carries droplets of the liquid agent with it as it permeates the volume. The droplets of liquid act as the principal fire-extinguishing agent. The high aerodynamic drag of the small droplets is an advantage as they are swept along by the expanding gas moving throughout the enclosure. The vaporizable liquid's main purpose is to carry the liquid fire-extinguishing agent throughout the enclosure.

## **Acknowledgments**

The authors are grateful for the financial support and continued encouragement from Steve McCormick, Mike Clauson, and Gerald Jung of the Halon Replacement Team of the U.S. Army Tank-Automotive Research, Development, and Engineering Center (TARDEC), Warren, MI.

INTENTIONALLY LEFT BLANK.

# Table of Contents

|   | <u>Page</u> |
|---|-------------|
| <b>Acknowledgments</b> .....  | iii         |
| <b>List of Figures</b> .....  | vii         |
| <b>1. Introduction</b> .....  | 1           |
| 1.1 Background .....  | 1           |
| 1.2 Description of Work .....   | 2           |
| <b>2. Description of the Device</b> .....                                     | 4           |
| <b>3. Mixing Chamber</b> .....  | 5           |
| <b>4. Discharge Rates to Extinguish Fires in the Desired Time Frame</b> ..... | 7           |
| <b>5. Collection of Data</b> .....  | 9           |
| <b>6. Results</b> .....   | 12          |
| 6.1 Large Chamber .....   | 12          |
| 6.2 Small Chamber .....   | 15          |
| <b>7. Conclusions</b> .....   | 16          |
| <b>8. Future Work</b> .....   | 17          |
| <b>Distribution List</b> .....  | 19          |
| <b>Report Documentation Page</b> .....  | 23          |

INTENTIONALLY LEFT BLANK.

# List of Figures

| <u>Figure</u> |  | <u>Page</u> |
|---------------|--|-------------|
| 1.            | The Device for Forming 3-D Water Droplets .....                    | 3           |
| 2.            | The Vortex Mixer and Water Droplets Within the Expanding Gas ..... | 4           |
| 3.            | Elements of the Vortex Mixer .....                                 | 6           |
| 4.            | The 1 1/2-in Mixing Tee With a FAASV Nozzle .....                  | 8           |
| 5.            | The Drying Tube Schematic.....                                     | 11          |
| 6.            | The Carrousel Droplet Collector .....                              | 12          |
| 7.            | Footprint of Water Droplet on Sugar-Coated Slide.....              | 15          |

INTENTIONALLY LEFT BLANK.

# 1. Introduction

**1.1 Background.** The U.S. Army is investigating alternatives to Halon 1301 for use in automatic fire-extinguishing systems (AFES) on board tactical vehicles. In general, a fully automatic system is installed in normally occupied spaces, such as crew compartments, and an automatic and/or manual system is used to combat engine compartment fires.

Any alternative to Halon 1301 must be acceptable from both environmental and toxicity standpoints. The most common fire-extinguishing agent, water, meets this requirement. Because of its high specific heat and high latent heat of vaporization, a mist of water droplets should be an excellent fire-extinguishing agent. However, there are two distinct disadvantages to the use of a water mist as a fire-extinguishing agent.

The first disadvantage is that a water mist is a streaming agent, i.e., its flow is directional. It normally flows in one direction until it encounters a surface on which it condenses or the velocity of the mist particles is reduced to approximately zero due to the high aerodynamic drag associated with small particles in air. In order for a mist to function effectively as an extinguishing agent, the location of the fire should be known ahead of time so that the mist generator can be properly oriented. An alternative is to detect the fire and then aim the mist in the correct direction. In either case, in order to use the mist efficiently, the location of the fire should be known, either before or during the event. If there is the possibility of a fire in multiple locations in a given space, multiple mist generators are required.

The second disadvantage of a water mist is the problem of droplet size. The most efficient mists are those with small droplets, since small droplets can completely evaporate in a flame maximizing the heat-absorbing ability of the water. Removing heat from a flame lowers its temperature and leads to flame extinguishment. However, small droplets have high aerodynamic drag and are difficult to propel any distance. Devices that generate small particle water mists should be located close to the anticipated flame zone of the fire.

The disadvantages associated with water mists would be overcome if water can be made to act as a three-dimensional (3-D) agent. A 3-D agent would permeate an enclosure. Therefore, the agent would reach a fire even if the fire were not directly in front of the discharge point. In addition, the agent would flow around obstacles in its path. The agent would encounter any fire in the enclosure. This report describes our approach to making water mist act as a 3-D agent.

**1.2 Description of Work.** A device that is capable of making and dispensing a water mist throughout an enclosure has been designed and constructed. The device can disseminate fine droplets of water in such a way as to make the droplets permeate an enclosure. Therefore, the water mist can act as a 3-D fire-extinguishing agent.

The device consists of two equally pressurized pressure bottles, fast-acting solenoid valves, a mixing chamber leading to a nozzle, and the necessary hardware to complete the system. One pressure bottle contains a vaporizable liquid, such as CO<sub>2</sub> or FE13 (trifluoromethane). The second pressure bottle contains a liquid fire-extinguishing agent, such as water or a water-based solution. The bottle containing the water is pressurized with CO<sub>2</sub> or FE13 so that both bottles are at the same pressure. Upon activation (opening) of the solenoid valves, two liquid streams (liquid CO<sub>2</sub> and liquid water) are directed into a static mixing chamber, such as a vortex mixer. The two streams are blended intimately in the chamber. Upon exiting the mixer through the nozzle, the vaporizable liquid flash evaporates and expands throughout the entire volume of an enclosure. This expanding gas carries droplets of the liquid fire-extinguishing agent with it as it permeates the volume. The high aerodynamic drag of the small droplets is an advantage as they are swept along by the expanding gas as it moves throughout the volume. The droplets of liquid act as the principal fire-extinguishing agent. A representation of the device is presented in Figure 1. A representation of a vortex mixer and the water droplets within the expanding gas is presented in Figure 2.

The vaporizable liquid (in the gaseous state) can contribute to the fire-extinguishing process; however, its main purpose is to act as a carrier for the liquid fire-extinguishing agent. This limits the amount of vaporizable agent required to the amount needed for dissemination. This will allow use of the vaporizable agent in small enough quantities that it does not exceed the

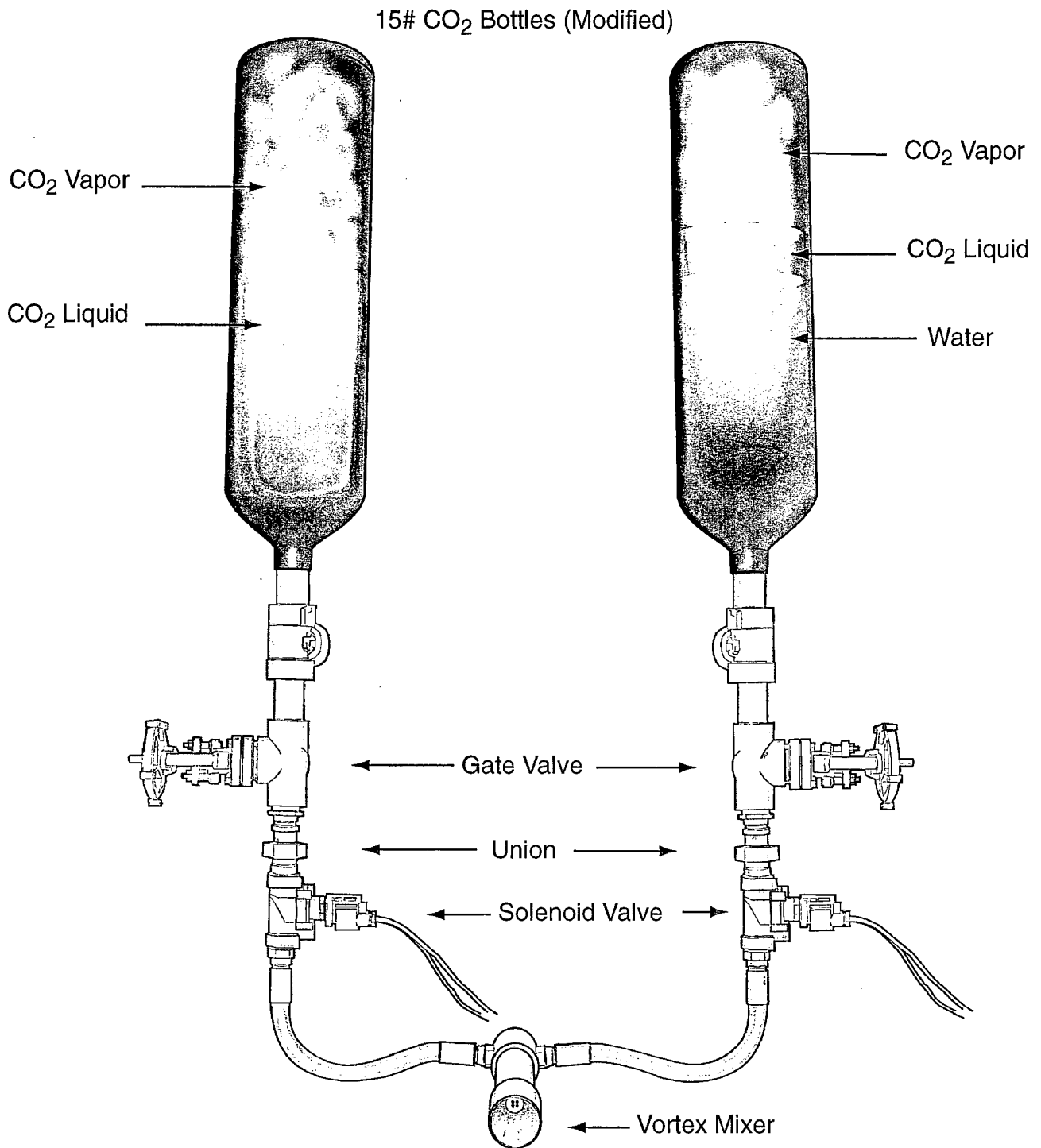

**Figure 1. The Device for Forming 3-D Water Droplets.**

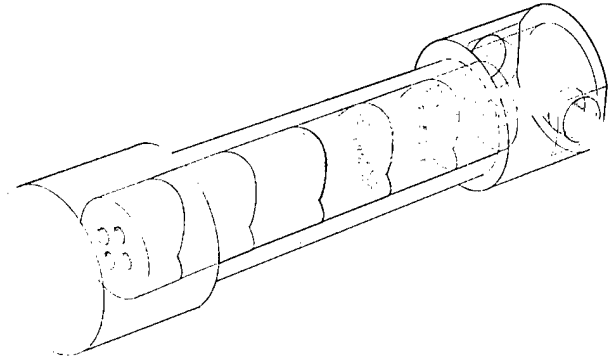

**Figure 2. The Vortex Mixer and Water Droplets Within the Expanding Gas.**

maximum concentration allowed by the EPA or the Army Surgeon General for use in occupied volumes.

## **2. Description of the Device**

The device consists of two main sections, a stationary section that is permanently connected to the experimental enclosure and a removable section. In the initial version of the system, the removable section consisted of two modified CO<sub>2</sub> fire extinguishers. The standard head and valve assemblies were removed from the bottles. Each bottle then received a gate valve connected to the bottle, an overpressure disc for safety reasons, and a quick-disconnect union. The union was used to connect/disconnect the bottle assembly to the stationary portion of the system. The bottles were easily removed from the system for refilling, then returned to the system for additional experiments.

In the initial version (no. 1), the valving and plumbing of both cylinders were identical. One end of a 1-in-diameter stainless steel nipple was screwed into a steel pressure bottle. The other end of the nipple was screwed into a 1-in stainless steel tee. A stainless steel plug, modified to hold a copper burst disc, was in another section of the tee. Since the burst disc had been removed from a CO<sub>2</sub> fire extinguisher, it had the proper pressure rating to protect the cylinders. The last section of the tee contained another 1-in stainless steel nipple. A cast-iron gate valve was attached to the other end of the 1-in stainless steel nipple. This valve was used to seal the cylinder after it was filled. In the fully opened position, the valve had a full 1-in opening. This offered no restriction to flow.

Following the gate valve were reducers to bring the diameter down to 1/2 in. A 1/2-in nipple followed and connected to a quick-disconnect union. The union facilitated assembly and disassembly of the system to refill the cylinders. The stationary portion of the system starts at the lower half of the union, which is attached to a 1/2-in opening on the solenoid valve. The valve was attached to a 1/2-in-diameter flexible hydraulic hose. The other end of the flexible hose, one from each cylinder assembly, is attached to a mixing chamber. The exit of the chamber had a nozzle, which delivered the water-mist fire-extinguishing agent to the enclosure.

### **3. Mixing Chamber**

The static, motionless mixer was the location where the two liquids (liquid CO<sub>2</sub> and liquid water) were mixed. Both streams entered the mixing chamber. Within the chamber, the two streams were intimately mixed to produce a virtually homogeneous mixture. The mixture exited the mixing chamber, into a nozzle, where the CO<sub>2</sub> flash vaporized and created a fine mist of water throughout the CO<sub>2</sub> gas.

In mixer version no. 1 (Figure 1), an interfacial surface generator (ISG) motionless mixer from Ross Engineering was used. This in-line mixer consisted of individual mixing units enclosed in a housing. Four holes were bored into each element to allow for flow, while the ends of the elements were machined to create a tetrahedral chamber between any two elements.

Within the tetrahedral chamber, the exit holes of one element were in a linear array 90° from the linear array of the entrance holes of the next element. A schematic of the elements of the mixer is presented in Figure 3.

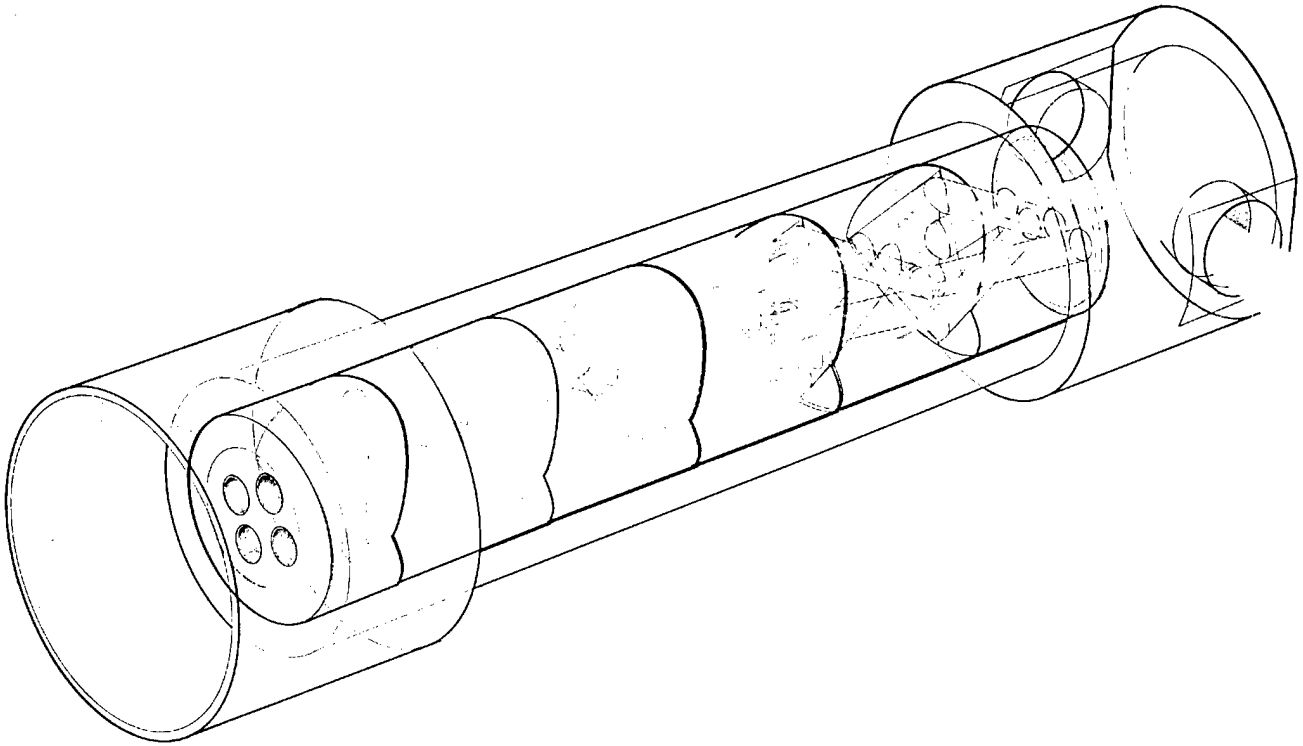

**Figure 3. Elements of the Vortex Mixer.**

ISG mixers are available up to 3-in-diameter models. The mixer, which was used in version no. 1, was a 1/2-in-diameter, five-element unit. This type mixer offers mathematically predictable layer generation. The layer generation is the number of layers at the exit side of an element. As an example, this device has two inlet streams entering four holes in the first element. Exiting the first element will be eight layers. The eight layers enter four holes in the second element. There are 32 layers, which exit the second element.

The number of layers emerging from an element is calculated using the formula\*

---

\* Intervalve, Ross Engineering, Inc., 32 Westgate Blvd., Savannah, GA 31405-1475.

$$L = N(4)^E,$$

where

L = number of layers created,

N = number of initial input streams (two in this case), and

E = number of elements.

In the case of the five elements of mixer version no. 1,

$$L = 2 \times (4)^5 = 2,048 \text{ layers.}$$

In mixer version no. 2, the mixing chamber was simply a 1 1/2-in-diameter tee. This size tee has a cross-section approximately the same as the sum of the cross-sections of the pair of 1-in-diameter hydraulic hoses, which fed the two liquid streams into the mixer. The field artillery ammunition support vehicle (FAASV) nozzle exit of the tee was also approximately 1 1/2 in diameter. A picture of the system is shown in Figure 4.

#### **4. Discharge Rates to Extinguish Fires in the Desired Time Frame**

The weight of water droplets per volume required to extinguish a fire has been estimated using many assumptions. A conservative (high) estimate would be about 500 mg of liquid water per liter of air.

In the crew compartment of a particular military vehicle, 7 lb of Halon 1301 are discharged to give an average concentration of 7% Halon 1301 in the air. This allows for the loss of agent due to losses from the compartment. A 7% concentration is equivalent to 469 mg of Halon 1301 per liter of air. This is approximately the weight of water required per liter. Therefore, approximately 7 lb of water should be required. This is equivalent to 3.2 liters.

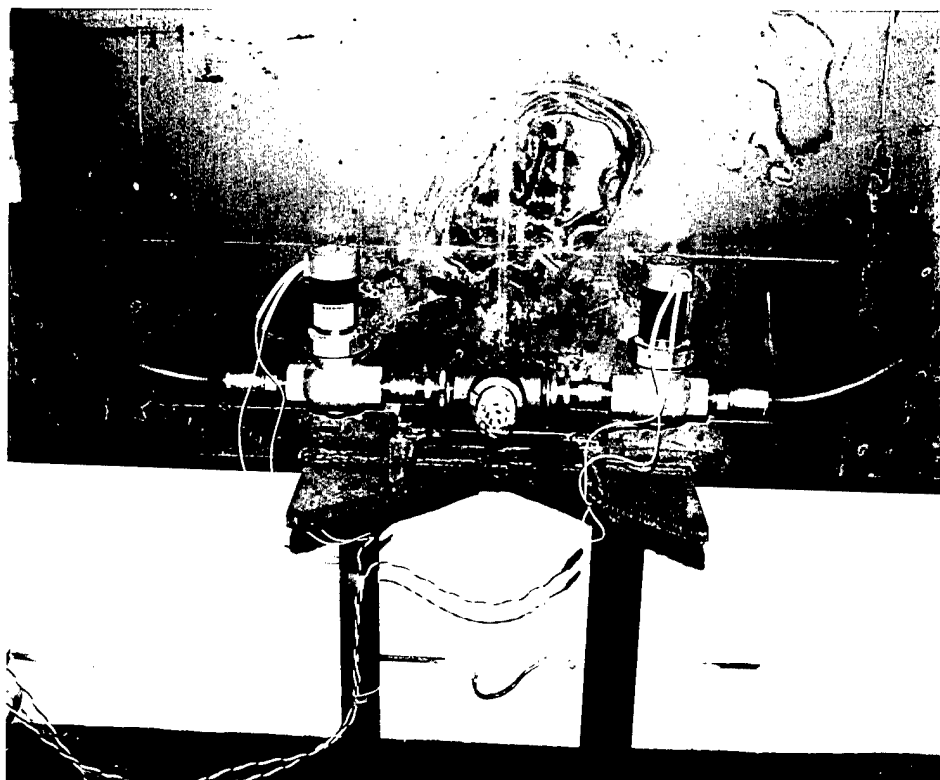

**Figure 4. The 1 1/2-in Mixing Tee With a FAASV Nozzle.**

If a low freezing point agent, such as 60-weight-percent potassium acetate in water solution, is used instead of neat water, considerably less agent will be required. Prior work has indicated that sprays of a 60-weight-percent solution of potassium acetate in water or a 60-weight-percent solution of potassium lactate in water is 10–20 times more effective than neat water at extinguishing JP-8 pan fires. Both solutions have a freezing point of approximately  $-60^{\circ}\text{C}$ . It is quite possible that as little as 1 liter of solution would be required.

With these data, it is conceivable that only 2 liters of liquid (1 liter of solution and 1 liter of liquid  $\text{CO}_2$ ) would be required to flow through the mixer. Current regulations require an extinguishment time of 250 ms in an occupied compartment. It takes 7 lb of Halon 1301 approximately 110 ms to discharge through the current nozzle. To determine the required ISG mixer size for turbulent flow that will accommodate this flow rate, the following formula is used:\*

---

\* Intervolve, Ross Engineering, Inc., 32 Westgate Blvd., Savannah, GA 31405-1475.

$$\Delta p = \frac{1.2 \times 10^{-1} Q^2 (spgr) \mu^{0.055}}{D^4},$$

where

- $p$  = pressure drop across one element,
- $Q$  = volumetric flow rate (gallons/minute),
- $spgr$  = specific gravity,
- $\mu$  = absolute viscosity, and
- $D$  = inside diameter of mixer housing (inches).

With CO<sub>2</sub>, approximately 740-psi vapor pressure is available at room temperature. Using a five-element, 3-in ISG mixer with CO<sub>2</sub>, a flow rate of 1,194 liters/min can be obtained. This correlates to 19.9 liters/s or 50.2 ms to discharge a liter. Therefore, two liters can be discharged through a 3-in mixer in 100.4 ms. This leaves approximately 150 ms to extinguish the fire and still be within the 250-ms required time frame.

## 5. Collection of Data

Certain data must be collected and analyzed in order to determine how well the fire-extinguishing device is functioning. Data have been collected on droplet size, droplet distribution in an enclosure with respect to location and time, concentration of CO<sub>2</sub> in the enclosure, and the ability of the device to actually extinguish fires.

The first data collection tool used was a set of arrays of conventional drying tubes. Each tube contained water-absorbing material and a porous plug. Each tube, with contents, is weighed prior to an experiment. The inlet of each tube is sealed with a rubber plug. The outlet of each tube is connected to a flow restrictor. The outlet of the flow restrictor is connected to a vacuum line, which connects to a manifold. There are five drying tubes connected to a manifold. At the end of the manifold is a solenoid valve leading to a vacuum source. There are nine manifolds

connected to a total of 45 drying tubes. Upon activation of a solenoid valve, vacuum is applied to five drying tubes, each in an array at a specified location in the experimental enclosure.

To obtain data on the weight of liquid agent per unit volume of air in the enclosure, the rubber seal is removed from each of the 45 tubes. The vacuum pump is constantly running during an experiment. After discharge of the water/water-based fire-extinguishing agent, individual solenoid valves are opened and closed. The timing is computer controlled. Based on the time a given solenoid valve is open and the flow rate through a restrictor, the volume of air that traveled through a given tube is calculated. Each tube is weighed after an experiment, and the weight gain is equated with the amount of water or water-based liquid in that particular volume of air. Water concentration can be calculated at five locations at nine different times. A schematic of the drying tube collection apparatus is presented in Figure 5.

Optical microscopy was employed to determine droplet size. Microscope slides coated with a very thin layer of silicone grease were used to collect the droplets. Nine slides were placed into a carousel, an early model of which is shown in Figure 6. The slides were covered by a disc having one opening. This disc could rotate so that the opening could be over a particular microscope slide or over a blank space between slides. A later model of the carousel used a computer-controlled stepping motor to turn the disc and position the opening in the disc over the desired microscope slide.

The slides collected droplets, which fell from the air, after activation of the fire-extinguishing device. The computer was programmed so that a given slide collected droplets for 10 s, in 10-s intervals.

It was found that water droplets evaporated too quickly to be photographed on a microscope slide so the droplet size could be measured. Therefore, instead of using silicone grease on the microscope slide, a piece of double-sided tape was taped to the slide. Then a dusting of 10× confectioners' sugar was placed on the tape and slide. When water droplets collected on the slides, the sugar dissolved into the water. Upon evaporation, footprints of the original droplets remained. The footprints gave a good indication of the size of the original droplets.

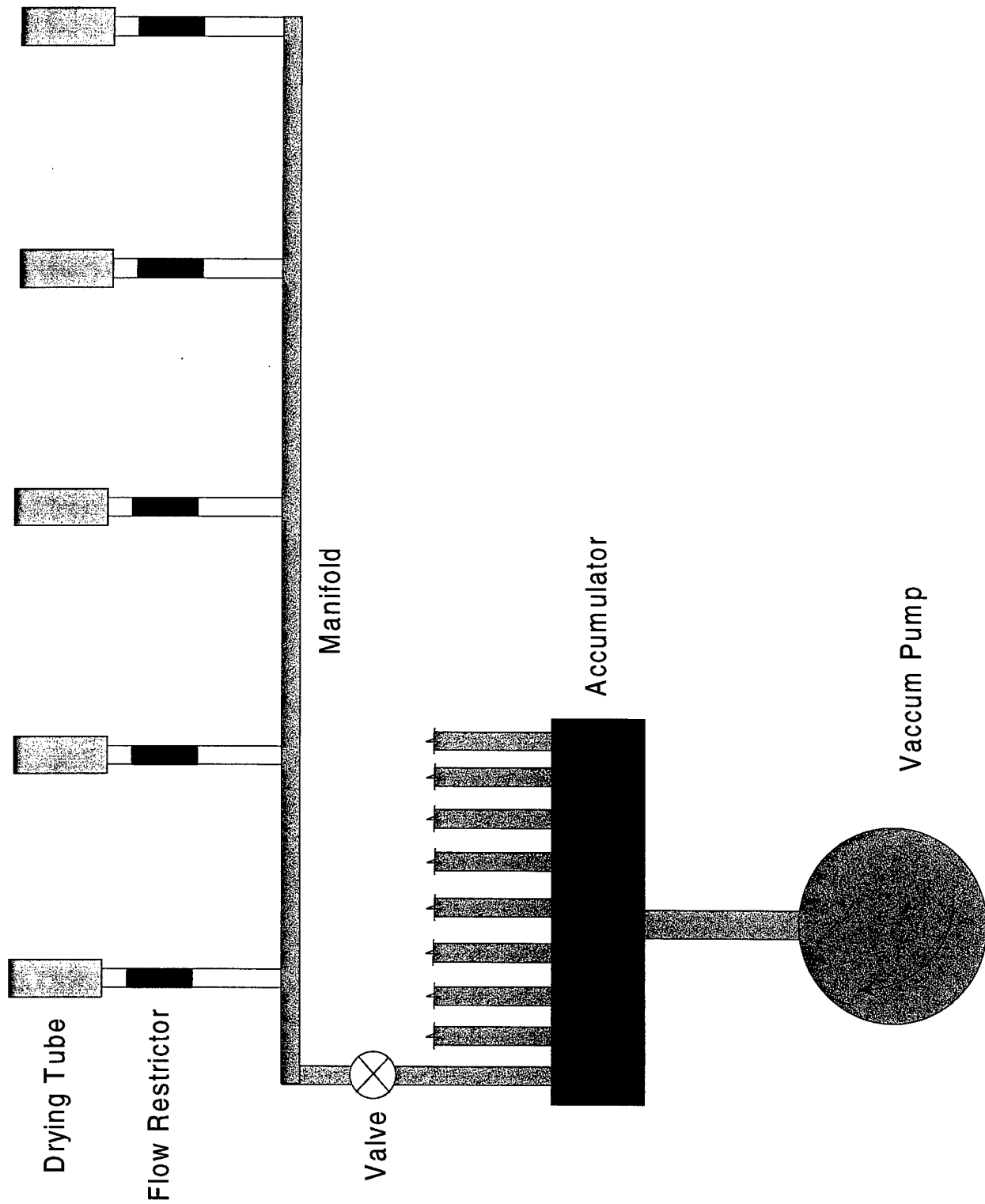
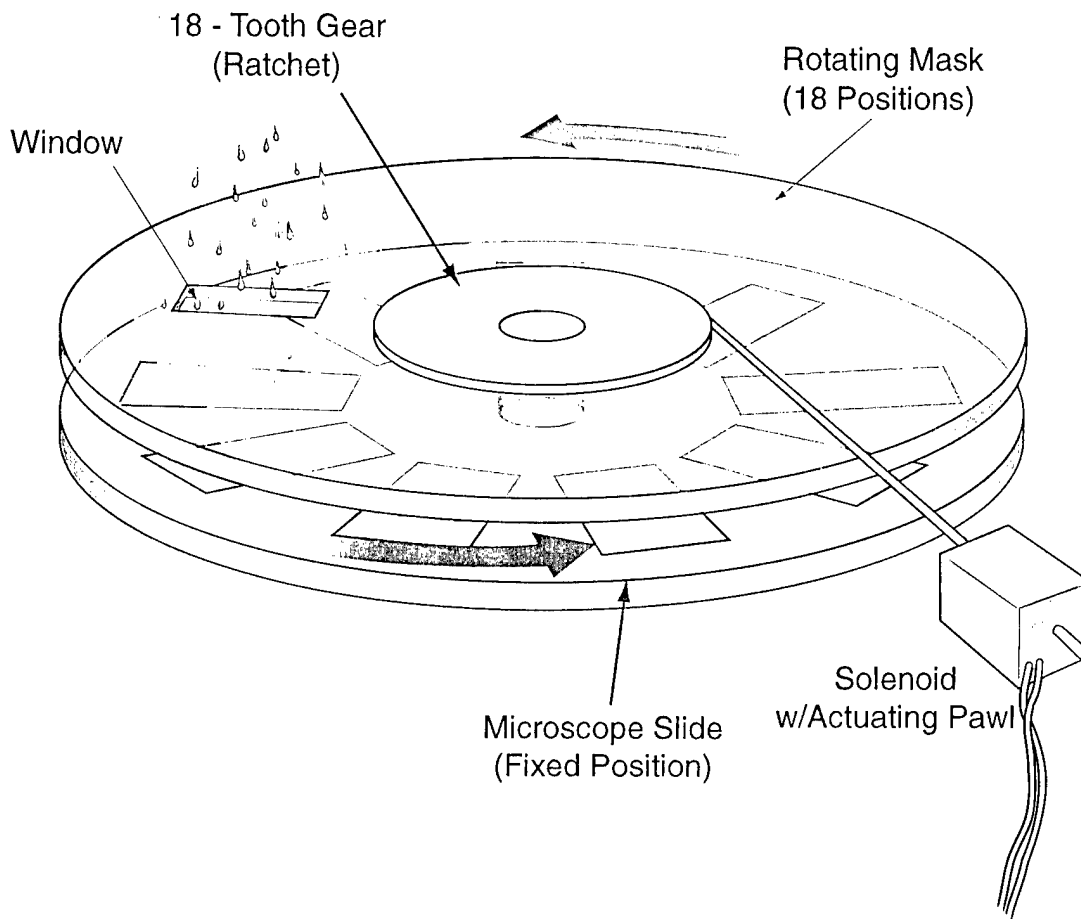

Figure 5. The Drying Tube Schematic.



**Figure 6. The Carrousel Droplet Collector.**

When water-based solutions containing a high concentration of salt, such as a 60% by weight potassium lactate and 40% by weight water solution are used, the droplets are collected on microscope slides, which have a thin coating of silicone grease. The sizes of the salt-water droplets do not appear to change even when left in air for a period of hours. These droplets can be photographed in the optical microscope and droplet sizes determined.

## 6. Results

**6.1 Large Chamber.** Initial experiments were performed in a chamber where volume was approximately 48.3 m<sup>3</sup>. The experiments used the five-element, 1/2-in-diameter vortex mixer. Each of the two pressure bottles were originally CO<sub>2</sub> fire-extinguisher bottles rated to contain

15 lb of CO<sub>2</sub>. The first phase of experiments was aimed at characterizing the capabilities of the system. A picture of the apparatus was presented in Figure 1.

The first experiment involved both pressure bottles, each containing 15-lb of CO<sub>2</sub>. The two solenoid valves were activated simultaneously. A thermocouple was placed at the exit nozzle of the device.

It was found that 45 s were required for discharge of the CO<sub>2</sub>. It was observed that the temperature of the thermocouple dropped to -65 °C. Water vapor condensed out of the air and froze on the vortex mixer. It was concluded that liquid CO<sub>2</sub> was evaporating in the vortex mixer. This caused an excessively long discharge time and the low temperature observed with the thermocouple and the ice formation in the vortex mixer.

In a follow-up experiment, 8 lb of CO<sub>2</sub> were put into one pressure bottle. One gallon of water was placed in the second bottle, and 2 lb of CO<sub>2</sub> were added to pressurize the water to the same value as the liquid CO<sub>2</sub> in the first bottle. Upon activation of the two solenoids, CO<sub>2</sub> and water mist were injected into the enclosure. CO<sub>2</sub> concentration was measured by continuously withdrawing gas from the enclosure into a nondispersive infrared CO<sub>2</sub> analyzer. Concentration of CO<sub>2</sub> peaked at 6%, the maximum value the machine could measure. Calculations indicated that a uniform concentration of CO<sub>2</sub> in the 48.3 m<sup>3</sup> enclosure would give a 2.2% CO<sub>2</sub> concentration. It is assumed that the cold CO<sub>2</sub> gas settled out low in the chamber.

The drying tube collectors were used for this experiment. Vacuum was applied to five tubes (each at a different location) for 10 s, starting with the electrical signal to the solenoid valves of the pressure bottles. After 10 s, the vacuum was removed from these tubes and switched to the second set of five tubes for 10 s. This process was repeated until all nine sets had been activated for 10 s of vacuum.

A calculation indicated that 1 gal of water, in the form of a mist in the chamber, would give an average concentration of 78 mg of water per liter. The highest concentration of water in the

air (eliminating drying tube that had been hit by direct discharge of water) was 37 mg per liter. Examination of the chamber after the experiment showed that much of the water was condensed on surfaces facing the discharge nozzle of the device.

Vapor was observed (by video) coming from the nozzle during the entire timed portion of the event (112 s). The direction of the vapors changed repeatedly during the discharge, likely caused by intermittent freezing and thawing of water in the channels of the vortex mixer.

The cylinders did not fully discharge during the event, probably due to all channels of the mixer freezing.

Water droplets were collected on sugar-coated microscope slides. The slides were on the carousel. While the carousel did not function properly during this experiment, some water droplets were collected. Figure 7 shows the footprint (dark area) on the sugar-coated slide. The largest footprint from the slide is 305  $\mu\text{m}$ , the median is 99  $\mu\text{m}$ , and the smallest is 33  $\mu\text{m}$ .

It has been estimated that approximately 500 mg of water mist per liter of air in a chamber would be required to extinguish a hydrocarbon fire. An average water mist of only 78 mg per liter would not be sufficient. An experiment was conducted using 10 lb of  $\text{CO}_2$  in one bottle and 1 gal of water with 3 lb of  $\text{CO}_2$  in the second bottle, with the mixing elements removed from the mixing chamber. A 3 5/8-in-diameter container, 7/8 in high, with 15 ml of burning cyclohexane was placed out of the direct path of the discharge. When the 1 gal of water was discharged, the pan fire was not extinguished.

In the next experiment, 1 gal of a 60% by weight potassium lactate, 40% by weight water solution was used in place of neat water. The pan fire was extinguished. Taking into consideration the 1.34 specific gravity of the solution, a uniform mist would give only approximately 104 mg of solution per liter of air in the chamber. The same volume of potassium lactate solution was more effective than water.

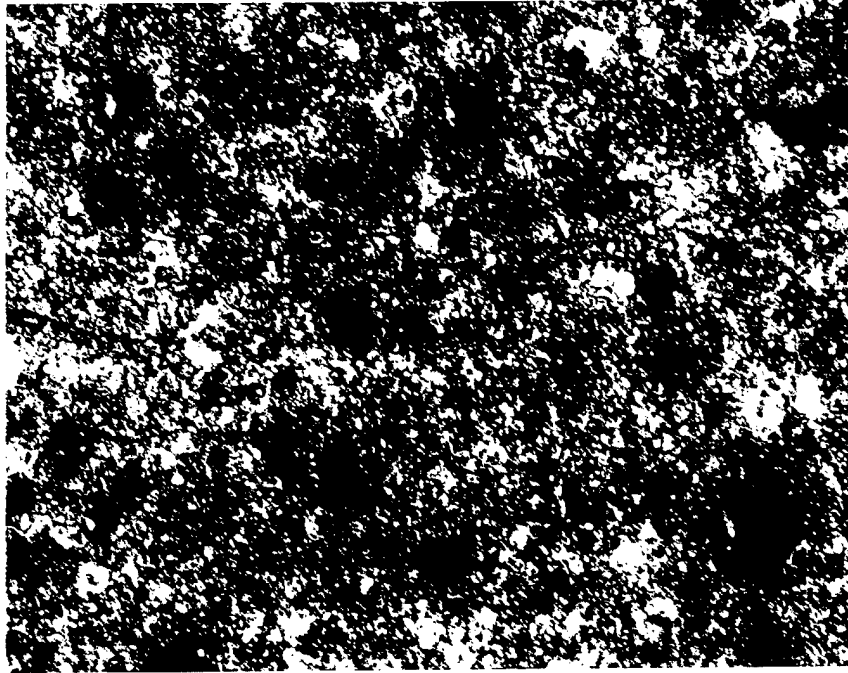

**Figure 7. Footprint of Water Droplet on Sugar-Coated Slide.**

**6.2 Small Chamber.** The experimental apparatus was installed in a bay whose volume was approximately  $23.2 \text{ m}^3$ . The hydraulic hoses were changed to 1-in-diameter hoses from the 1/2-in-diameter hoses formerly used. The mixing chamber used was a simple 1 1/2-in tee. The two hydraulic hoses (one from each pressure bottle) fed into the two inlets of the tee. The outlet of the tee had a nozzle of the type used on the M992 FAASV vehicle Halon 1301 fire-extinguishing system. A picture of the apparatus was shown in Figure 4. One gallon of water was used along with the  $\text{CO}_2$ . Two pans of burning cyclohexane were used. The pans were out of the direct line of the  $\text{CO}_2$  propelled water mist. Upon activation of the two solenoids, both fires were extinguished. A dense fog was observed in the bay. The simple mixing chamber and nozzle combination appear to be very much superior to the complex (ISG) mixer and nozzle used previously.

All four subsequent experiments using 1 gal of the potassium lactate solution extinguished the pan fires. The fires, even with pans placed behind the apparatus, gave fire out times as low as 132 ms. The mist appears to uniformly cover the bay. This is what was desired.

Pictures of the microscope slides taken in these experiments have been scanned, and histograms have been constructed by a computer program. The histograms show that most of the droplets of the potassium lactate solution are in the 1–2  $\mu\text{m}$  size range. This is consistent with the uniform fog in the bay. These very small droplets can be carried along by the expanding  $\text{CO}_2$ , giving excellent distribution of the fire-extinguishing agent (the liquid droplets) throughout the enclosure.

## 7. Conclusions

- The five-element, 1/2-in-diameter vortex mixer was not suitable for use with liquid  $\text{CO}_2$  and water. The liquid evaporated in the mixer, freezing the water, which blocked channels in the elements.
- A simple, large-diameter (1 1/2 in) tee mixer with opposed flow inlets and a perforated nozzle outlet is quite satisfactory. Flow is rapid and very small (1–2  $\mu\text{m}$ ) droplets are formed.
- A 60% by weight potassium lactate, 40% by weight water solution, is superior to water as the fire-extinguishing agent.
- The device does allow the expanding, boiling gas to carry liquid fire-extinguishing droplets to all portions of an enclosure.
- The device will extinguish pan fires that are placed out of the lined sight of the discharge nozzle in a little as 132 ms.

## 8. Future Work

A follow-up model of the device has been constructed using U.S. Army vehicle fire-extinguishing equipment. Pressure bottles and 24-volt solenoid valves used in combat vehicles are being used. The 1 1/2-in tee mixer and FAASV perforated nozzle are retained. When the system has been demonstrated capable of extinguishing fires in a test chamber, it will be delivered to TARDEC for testing in the crew compartments of combat vehicles.

INTENTIONALLY LEFT BLANK.

| <u>NO. OF COPIES</u> | <u>ORGANIZATION</u>  |
|----------------------|--|
| 2                    | DEFENSE TECHNICAL<br>INFORMATION CENTER<br>DTIC DDA<br>8725 JOHN J KINGMAN RD<br>STE 0944<br>FT BELVOIR VA 22060-6218  |
| 1                    | HQDA<br>DAMO FDT<br>400 ARMY PENTAGON<br>WASHINGTON DC 20310-0460  |
| 1                    | OSD<br>OUSD(A&T)/ODDDR&E(R)<br>R J TREW<br>THE PENTAGON<br>WASHINGTON DC 20301-7100                                    |
| 1                    | DPTY CG FOR RDA<br>US ARMY MATERIEL CMD<br>AMCRDA<br>5001 EISENHOWER AVE<br>ALEXANDRIA VA 22333-0001                   |
| 1                    | INST FOR ADVNCD TCHNLGY<br>THE UNIV OF TEXAS AT AUSTIN<br>PO BOX 202797<br>AUSTIN TX 78720-2797                        |
| 1                    | DARPA<br>B KASPAR<br>3701 N FAIRFAX DR<br>ARLINGTON VA 22203-1714  |
| 1                    | US MILITARY ACADEMY<br>MATH SCI CTR OF EXCELLENCE<br>MADN MATH<br>MAJ HUBER<br>THAYER HALL<br>WEST POINT NY 10996-1786 |
| 1                    | DIRECTOR<br>US ARMY RESEARCH LAB<br>AMSRL D<br>D R SMITH<br>2800 POWDER MILL RD<br>ADELPHI MD 20783-1197               |

| <u>NO. OF COPIES</u> | <u>ORGANIZATION</u>  |
|----------------------|--|
| 1                    | DIRECTOR<br>US ARMY RESEARCH LAB<br>AMSRL DD<br>2800 POWDER MILL RD<br>ADELPHI MD 20783-1197                     |
| 1                    | DIRECTOR<br>US ARMY RESEARCH LAB<br>AMSRL CI AI R (RECORDS MGMT)<br>2800 POWDER MILL RD<br>ADELPHI MD 20783-1145 |
| 3                    | DIRECTOR<br>US ARMY RESEARCH LAB<br>AMSRL CI LL<br>2800 POWDER MILL RD<br>ADELPHI MD 20783-1145                  |
| 1                    | DIRECTOR<br>US ARMY RESEARCH LAB<br>AMSRL CI AP<br>2800 POWDER MILL RD<br>ADELPHI MD 20783-1197                  |
|                      | <u>ABERDEEN PROVING GROUND</u>   |
| 4                    | DIR USARL<br>AMSRL CI LP (BLDG 305)  |

| <u>NO. OF COPIES</u> | <u>ORGANIZATION</u>  | <u>NO. OF COPIES</u> | <u>ORGANIZATION</u>   |
|----------------------|--|----------------------|---|
| 1                    | OSD OUSDRE (T&E)<br>J O BRYAN<br>PENTAGON 3D116<br>WASHINGTON DC 20301-3110  | 1                    | HQ AFESC RDCF<br>FIRE TECHNOLOGY BR<br>W BANNISTER<br>TYNDALL AFB FL 32403-6001                   |
| 4                    | COMMANDER<br>US ARMY TARDEC<br>AMSTA JSS<br>J THOMPSON<br>S MCCORMACK<br>M CLAUSON<br>G JUNG<br>WARREN MI 48397-5000 | 1                    | BLAZE TECH CORP<br>A MOUSSA<br>24 THORNDIKE ST<br>CAMBRIDGE MA 02141-1882                         |
| 1                    | COMMANDER<br>US ARMY TARDEC<br>AMSTA UEB<br>MR RAO<br>WARREN MI 48397-5000   | 1                    | SOUTHWEST RESEARCH INST<br>B WRIGHT<br>6220 CULEBRA RD<br>PO DRAWER 28510<br>SAN ANTONIO TX 78284 |
|                      |  |                      | <u>ABERDEEN PROVING GROUND</u>  |
| 1                    | COMMANDER<br>US ARMY TARDEC<br>AMSTA JWF<br>J MIATECH<br>WARREN MI 48397-5000  | 2                    | DIR USACSTA EN<br>C HERUD<br>W BOLT<br>APG MD 21005   |
| 1                    | US ARMY TARDEC<br>PEO ASM<br>SFAE ASM S<br>C BEAUDETTE<br>WARREN MI 48397-5000                                       | 2                    | DIR AMSAA<br>M CARROL<br>L KRAVITZ<br>APG MD 21005  |
| 1                    | PM AFAS<br>SFAE ASM AF<br>T KURIATA<br>PICATINNY ARSENAL NJ<br>07806-5000  | 1                    | CDR US ARMY DTC<br>H HARRINGTON<br>APG MD 21005   |
| 2                    | COMMANDER<br>US ARMY TRADOC<br>PM SURVIVABILITY SYSTEMS<br>SFAE ASM SS<br>M RYZYI<br>T DEAN<br>WARREN MI 48397-5000  | 4                    | DIR USAATC<br>STECs LI U<br>S POLYANSKI<br>J MILLER<br>B SOKOLIS<br>J MCFASSEL<br>APG MD 21005    |

NO. OF  
COPIES    ORGANIZATION

ABERDEEN PROVING GROUND (CONT)

23    DIR USARL  
      AMSRL WM B  
      A HORST  
      AMSRL WM BA  
      W D AMICO  
      L BURKE  
      P PEREGINO (10 CPS)  
      AMSRL WM BD  
      A MIZIOLEK  
      R WAINNER  
      AMSRL WM T  
      B BURNS  
      AMSRL WM TB  
      R FREY  
      J WATSON  
      L VANDEKIEFT (2 CPS)  
      R SKAGGS  
      AMSRL SL BG  
      J PLOSKONKA  
      P KUSS

INTENTIONALLY LEFT BLANK.

| REPORT DOCUMENTATION PAGE  |   |  | Form Approved<br>OMB No. 0704-0188                                  |  |
|--|---|--|---|--|
| Public reporting burden for this collection of information is estimated to average 1 hour per response, including the time for reviewing instructions, searching existing data sources, gathering and maintaining the data needed, and completing and reviewing the collection of information. Send comments regarding this burden estimate or any other aspect of this collection of information, including suggestions for reducing this burden, to Washington Headquarters Services, Directorate for Information Operations and Reports, 1215 Jefferson Davis Highway, Suite 1204, Arlington, VA 22202-4302, and to the Office of Management and Budget, Paperwork Reduction Project(0704-0188), Washington, DC 20503.  |   |  |   |  |
| 1. AGENCY USE ONLY (Leave blank)   |   | 2. REPORT DATE<br>October 2000                             | 3. REPORT TYPE AND DATES COVERED<br>Final, October 1996 - July 1999 |  |
| 4. TITLE AND SUBTITLE<br>Water as a Three-Dimensional Fire-Extinguishing Agent   |   |  | 5. FUNDING NUMBERS<br>78T8F1  |  |
| 6. AUTHOR(S)<br>Philip J. Peregino II, Anthony E. Finnerty, Robert McGill,<br>Lawrence J. Vande Kieft,* and Dawnn Saunders†  |   |  |   |  |
| 7. PERFORMING ORGANIZATION NAME(S) AND ADDRESS(ES)<br>U.S. Army Research Laboratory<br>ATTN: AMSRL-WM-TB<br>Aberdeen Proving Ground, MD 21005-5066   |   |  | 8. PERFORMING ORGANIZATION<br>REPORT NUMBER<br>ARL-TR-2357          |  |
| 9. SPONSORING/MONITORING AGENCY NAMES(S) AND ADDRESS(ES)   |   |  | 10. SPONSORING/MONITORING<br>AGENCY REPORT NUMBER                   |  |
| 11. SUPPLEMENTARY NOTES<br>* Faith Farm, 4258 Federal Hill Road, Street, MD 21154<br>† DSI Corporation, Aberdeen Proving Ground, MD 21005  |   |  |   |  |
| 12a. DISTRIBUTION/AVAILABILITY STATEMENT<br>Approved for public release; distribution is unlimited.  |   |  | 12b. DISTRIBUTION CODE  |  |
| 13. ABSTRACT (Maximum 200 words)<br><p>It is generally believed that, because of its ability to absorb large quantities of heat, a mist of water droplets would be an excellent fire-extinguishing agent. A device has been constructed to disseminate a high volume of fine droplets of a liquid agent (water) in such a way as to make the liquid droplets permeate an enclosure. This device is capable of dispersing a water mist throughout a volume. Thus, the water mist can act as a three-dimensional agent, much like gaseous agents.</p> <p>The device consists of two equally pressurized cylinders, fast-acting solenoid valves, a mixing chamber, and the necessary hardware to complete the system. One cylinder contains a vaporizable liquid, such as CO<sub>2</sub>, and the second contains a liquid agent, such as water or water-based solution pressurized with CO<sub>2</sub> or nitrogen. Upon activating the solenoid valves, two liquid streams (CO<sub>2</sub> and water or water-based solution) are directed into a mixing chamber, such as a vortex mixer. The two streams are blended intimately in the chamber. Upon exiting the mixer into a nozzle, the vaporizable liquid flash evaporates and expands throughout the volume of an enclosure. This expanding gas carries droplets of the liquid agent with it as it permeates the volume. The droplets of liquid act as the principal fire-extinguishing agent. The high aerodynamic drag of the small droplets is an advantage as they are swept along by the expanding gas moving throughout the enclosure. The vaporizable liquid's main purpose is to carry the liquid fire-extinguishing agent throughout the enclosure.</p> |   |  |   |  |
| 14. SUBJECT TERMS<br>water, water mist, droplets, fire-extinguishing agent, 3-D agent, vaporizable liquid, carbon dioxide, mixer, vortex mixer, potassium lactate, halon, Halon 1301, flooding, total flooding agent   |   |  | 15. NUMBER OF PAGES<br>26   |  |
|  |   |  | 16. PRICE CODE  |  |
| 17. SECURITY CLASSIFICATION<br>OF REPORT<br>UNCLASSIFIED   | 18. SECURITY CLASSIFICATION<br>OF THIS PAGE<br>UNCLASSIFIED | 19. SECURITY CLASSIFICATION<br>OF ABSTRACT<br>UNCLASSIFIED | 20. LIMITATION OF ABSTRACT<br>UL                                    |  |

INTENTIONALLY LEFT BLANK.

**USER EVALUATION SHEET/CHANGE OF ADDRESS**

This Laboratory undertakes a continuing effort to improve the quality of the reports it publishes. Your comments/answers to the items/questions below will aid us in our efforts.

1. ARL Report Number/Author ARL-TR-2357 (Peregino) Date of Report October 2000

2. Date Report Received \_\_\_\_\_

3. Does this report satisfy a need? (Comment on purpose, related project, or other area of interest for which the report will be used.) \_\_\_\_\_  
\_\_\_\_\_  
\_\_\_\_\_

4. Specifically, how is the report being used? (Information source, design data, procedure, source of ideas, etc.) \_\_\_\_\_  
\_\_\_\_\_  
\_\_\_\_\_

5. Has the information in this report led to any quantitative savings as far as man-hours or dollars saved, operating costs avoided, or efficiencies achieved, etc? If so, please elaborate. \_\_\_\_\_  
\_\_\_\_\_

6. General Comments. What do you think should be changed to improve future reports? (Indicate changes to organization, technical content, format, etc.) \_\_\_\_\_  
\_\_\_\_\_  
\_\_\_\_\_  
\_\_\_\_\_

**CURRENT  
ADDRESS**

\_\_\_\_\_  
**Organization**

\_\_\_\_\_  
**Name**

\_\_\_\_\_  
**E-mail Name**

\_\_\_\_\_  
**Street or P.O. Box No.**

\_\_\_\_\_  
**City, State, Zip Code**

7. If indicating a Change of Address or Address Correction, please provide the Current or Correct address above and the Old or Incorrect address below.

**OLD  
ADDRESS**

\_\_\_\_\_  
**Organization**

\_\_\_\_\_  
**Name**

\_\_\_\_\_  
**Street or P.O. Box No.**

\_\_\_\_\_  
**City, State, Zip Code**

(Remove this sheet, fold as indicated, tape closed, and mail.)

**(DO NOT STAPLE)**

---

DEPARTMENT OF THE ARMY

OFFICIAL BUSINESS

**BUSINESS REPLY MAIL**  
FIRST CLASS PERMIT NO 0001,APG,MD

POSTAGE WILL BE PAID BY ADDRESSEE

DIRECTOR  
US ARMY RESEARCH LABORATORY  
ATTN AMSRL WM TB  
ABERDEEN PROVING GROUND MD 21005-5066

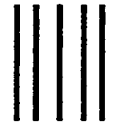

NO POSTAGE  
NECESSARY  
IF MAILED  
IN THE  
UNITED STATES

