

ARMY RESEARCH LABORATORY



Mechanical and Ballistic Data for Al2519 Plate, Forgings, and Weldments

by Scott M. Grendahl, Richard J. Squillaciotti,
Daniel J. Snoha, and Christopher E. Miller

ARL-TR-2452

April 2001

20010418 110

Approved for public release; distribution is unlimited.

The findings in this report are not to be construed as an official Department of the Army position unless so designated by other authorized documents.

Citation of manufacturer's or trade names does not constitute an official endorsement or approval of the use thereof.

Destroy this report when it is no longer needed. Do not return it to the originator.

Army Research Laboratory

Aberdeen Proving Ground, MD 21005-5066

ARL-TR-2452

April 2001

Mechanical and Ballistic Data for A12519 Plate, Forgings, and Weldments

Scott M. Grendahl, Richard J. Squillacioti,
Daniel J. Snoha, and Christopher E. Miller
Weapons and Materials Research Directorate, ARL

Abstract

The development and potential use of aluminum-armor alloys in the design and construction of combat vehicles has been repeatedly scrutinized as the military continually pushes toward lightweight, mobile, and more deployable forces. In doing so, it is necessary to fully characterize and understand the engineering material properties and the ballistic resistance of any prospective material. Aluminum 2519 (Al2519) was developed nearly 20 years ago as a high-strength, heat-treatable alloy with excellent ballistic performance. This alloy was not utilized extensively beyond the experimental phase and as such has not been continually produced by the aluminum industry. Therefore, when the utilization of this alloy recently became expected, questions arose about the ability of the suppliers to reproduce the same product that had been developed in the past. As part of the ensuing analysis, the engineering properties and the chemical and ballistic resistance of the alloy required validation. Additionally, work needed to be performed to verify that the alloy and its various heat treatments were feasible for joining in the construction of armored vehicles. Several common heat treatments were characterized, in addition to the most common weld joints presently designed by Team Crusader.

Acknowledgments

The authors would like to thank Brian Pothier and Marc Pepi of the Processing and Properties Branch, and Dr. Martin Wells, John Chinella, and Chris Miller of the Metals and Ceramics Research Branch for their support in preparing the U.S. Army Research Laboratory (ARL) program for Team Crusader. Multiple changes to the original program were made throughout this effort, and their assistance was invaluable. The authors would also like to thank Dr. Bill Herman from General Dynamics Land Systems (GDLS), Rick Brynsvold from United Defense Limited Partnership (UDLP), and Dale Roark from the U.S. Army Tank-automotive and Armaments Command (TACOM) for their assistance in obtaining funding and material for testing, as well as for many rewarding discussions. Richard Squillaciotti would like to acknowledge the support of the U.S. Aberdeen Test Center (ATC), especially Gary Rowe and Barbara Kaschenbach, for all the required ballistic testing and evaluations.

INTENTIONALLY LEFT BLANK.

Table of Contents

	<u>Page</u>
Acknowledgments	iii
List of Figures	vii
List of Tables	ix
1. Introduction	1
1.1 Materials Characterization	1
1.2 Ballistic Characterization.....	1
1.2.1 <i>Part A</i>	1
1.2.2 <i>Part B</i>	2
1.3 Program Objectives.....	2
2. Procedures	2
2.1 Mechanical Property and Chemical Resistance Characterization of Al2519	2
2.1.1 <i>Tensile Testing</i>	5
2.1.2 <i>Fatigue Testing</i>	6
2.1.3 <i>General Corrosion</i>	7
2.1.4 <i>Pitting Corrosion</i>	7
2.1.5 <i>Stress Corrosion Cracking</i>	10
2.2 Ballistic Characterization of Al2519 Plate and Welds	10
3. Testing and Results	14
3.1 Mechanical Property and Chemical Resistance Characterization of Al2519	14
3.1.1 <i>Tensile Testing</i>	14
3.1.2 <i>Fatigue Testing</i>	14
3.1.3 <i>General Corrosion</i>	14
3.1.4 <i>Pitting Corrosion</i>	26
3.1.5 <i>Stress Corrosion Cracking</i>	28
3.2 Ballistic Characterization of Al2519 Plate and Welds	32
4. Summary and Conclusion	39
4.1 Part 1: Mechanical Property and Chemical Resistance Characterization	39
4.2 Part 2: Ballistic Characterization	44

	<u>Page</u>
5. References	45
Appendix A: Amendment 1 to MIL-DTL-46192 C (MR)	47
Appendix B: Individual Test Shots for Developing the V₅₀ Acceptance Tables	53
Distribution List	75
Report Documentation Page	77

List of Figures

<u>Figure</u>	<u>Page</u>
1. Single-V Joint Schematic With Longitudinal Specimen Orientation	5
2. Double-V Joint Schematic With Transverse Specimen Orientation.....	5
3. Tensile Specimen Schematic	6
4. Rotating-Beam (R. R. Moore) Specimen Schematic	8
5. Axial Fatigue Specimen for Unwelded Base Material.....	8
6. Axial Fatigue Specimen for Welded Material	9
7. Welded-Plate Axial Fatigue Specimen Orientation	9
8. SCC C-Ring Specimen Schematic.....	10
9. SCC Sandwich Specimen Schematic.....	11
10. Disassembled 75-mm Aluminum Projectile.	12
11. Assembled 75-mm Aluminum Projectile.....	12
12. Rotating Beam and Axial Fatigue Data for the T87-T87 Weldment, R-Ratio = -1, Kt = 1	22
13. Rotating Beam and Axial Fatigue Data for the T87 Base Plate, R-Ratio = -1, Kt = 1	22
14. Rotating Beam and Axial Fatigue Data for the T6 Surrogate, R-Ratio = -1, Kt = 1	23
15. T87-T87 100-Hr Salt-Fog-Exposed R. R. Moore Specimen	23
16. T87 Base Alloy 100-Hr Salt-Fog-Exposed R. R. Moore Specimen	24
17. T6 Surrogate 100-Hr Salt-Fog-Exposed R. R. Moore Specimen	24
18. Surface Detail of T87-T87 100-Hr Salt-Fog-Exposed R. R. Moore Specimen.....	25

<u>Figure</u>	<u>Page</u>
19. Surface Detail of T87 Base Alloy 100-Hr Salt-Fog-Exposed R. R. Moore Specimen	25
20. Surface Detail of T6 Surrogate 100-Hr Salt-Fog-Exposed R. R. Moore Specimen	26
21. T87-T87 With 2319 Filler Metal Corrosion Specimen After Chemical Cleaning....	26
22. T6 Corrosion Specimen After Chemical Cleaning.....	27
23. T87-T87 With 2319 Filler Metal Corrosion Specimen After Chemical Cleaning....	28
24. C-Rings and Sandwich Specimens After One Day of Salt-Fog Exposure.....	29
25. C-Rings and Sandwich Specimens After 10 Days of Salt-Fog Exposure.....	29
26. Cleaned C-Ring Specimens After 10 Days of Salt-Fog Exposure.....	30
27. Cleaned Sandwich Specimens After 10 Days of Salt-Fog Exposure.....	30
28. Details of Cleaned C-Ring Specimens After 10 Days of Salt-Fog Exposure	31
29. Details of Cleaned Sandwich Specimen After 10 Days of Salt-Fog Exposure.....	31
30. 75-mm Projectile Test Firing 30-1-1.....	35
31. 75-mm Projectile Test Firing 30-2-1.....	35
32. 75-mm Projectile Test Firing 35-5 After Both Shots (Front)	36
33. 75-mm Projectile Test Firing 35-5 After Both Shots (Back)	36
34. 75-mm Projectile Test Firing 50-2 After Both Shots (Front)	37
35. 75-mm Projectile Test Firing 50-2 After Both Shots (Back)	37

List of Tables

<u>Table</u>	<u>Page</u>
1. Material Characterization Test Matrix for Al2519 Forgings, Plate, and Weldments	4
2. Ballistic Curve Development Table.....	13
3. Tensile and Elongation Data for the T87-T87 Weldments.....	15
4. Tensile and Elongation Data for the T87-T6 Weldments.....	15
5. Tensile and Elongation Data for the T6 Alloy.....	16
6. R. R. Moore Rotating-Beam Fatigue Data for the T87-T87 Weldments.....	17
7. Axial Fatigue Data for the T87-T87 Weldments	18
8. R. R. Moore Rotating-Beam Fatigue Data for the T87 Alloy.....	19
9. Axial Fatigue Data for the T87 Alloy	19
10. R. R. Moore Rotating-Beam Fatigue Data for the T6 Alloy.....	20
11. Striking Velocity Data	33
12. Minimum Required Striking Velocity Ballistic Limits.....	34
13. V ₅₀ Velocity Data	38
14. Minimum Required Ballistic Limits 0.50-cal. AP M2 Projectiles vs. Al2519 Plate at 0° Obliquity.....	40
15. Minimum Required Ballistic Limits 14.5-mm BS 41 Projectiles vs. Al2519 Plate at 0° Obliquity.....	42
B-1. Individual Test Shots for Developing the V ₅₀ Acceptance Tables	55

INTENTIONALLY LEFT BLANK.

1. Introduction

1.1 Materials Characterization. The FY99 program objectives were accomplished by substantiating the values of the material properties of the Al2519 base metal, heat treatments, and weldment mechanical properties, and by specifically addressing weldment toughness and stress corrosion cracking (SCC) in the weldment and heat-affected zones (HAZs). A good deal of mechanical property data was previously published for this material. This work made an attempt to validate the existing data and fill in some of the pertinent data voids. Several proposals were provided to the U.S. Army Tank-automotive and Armaments Command (TACOM) by the U.S. Army Research Laboratory (ARL) to address these issues. TACOM, United Defense Limited Partnership (UDLP), and General Dynamics Land Systems (GDLS) agreed on a subset of those proposals. This involved limited tensile and corrosion testing and somewhat more extensive fatigue testing. An evaluation of the corrosion resistance was critical, including SCC of both the T6 forging base plate and the weld/HAZ of the various heat treatment/alloy combinations to be utilized.

1.2 Ballistic Characterization. To deliver the best products to the soldier, requirements are specified and quality assurance provisions (or verification or certification) are developed that provide the accept/reject criteria for determining whether the U.S. Government will use an item. The two ballistic standardization documents, MIL-STD-1946 [1] and MIL-A-46192 [2], had voids that needed to be addressed. The ballistic characterization effort was divided into two parts:

- Part A: develop acceptance criteria (striking velocities) for weldments, and
- Part B: develop two ballistic acceptance tables for MIL-A-46192 [2] and incorporate them into the specification via an amendment, and retitling the specification MIL-DTL-46192.

1.2.1 Part A. The Part A effort concentrated on updating MIL-STD-1946 [1] (a canceled document) by adding striking velocities for 15-, 20-, 25-, 30-, 35-, and 50-mm-thick Al2519 base plate. The 57-mm M1001A plate-proofing projectile was proposed for thicknesses between

15 and 25 mm. The 75-mm M1002A plate-proofing projectile was proposed for thicknesses between 30 and 50 mm. Both projectiles are made of aluminum. The Al2519 material utilized was supplied by the Office of the Program Manager (OPM).

1.2.2 Part B. The Part B effort also utilized a canceled document, MIL-A-46192 [2]; however, the standardization group that governs the upkeep of documents was persuaded to reinstate the specification after much discussion. The reinstated document was designated MIL-A-46192 [2]. The two required tables that needed to be generated were specified by the OPM so that material could be bought and accepted up to 4.000 in. These included both the ballistic limit of Al2519 vs. the 0.50-cal. projectile for 1.5–3.0-in thickness, and the ballistic limit of Al2519 vs. the 14.5-mm BS41 projectile for 3.0–4.0-in thickness.

1.3 Program Objectives. This work encompassed the agreed-upon revisions to the previous package submitted to OPM Crusader on 30 June 1998. Changes were incorporated to more effectively address the Crusader requirements. The objective of this effort was to provide mechanical, chemical resistance, and ballistic data on the high-strength Al2519 base plate and weldments of some heat treatments of the alloy. The mechanical property and chemical resistance data were suitable for the material certification and structural design of the vehicle's chassis. The ballistic information will fill the voids in the ballistic shock database, which is required to address the welding procedure qualification requirements and weldment ballistic shock loading requirements. Additionally, ballistic acceptance criteria were developed for plate thicknesses over 1.5 in. The data acquired will be used for determining the quality and consistency of the weld procedure.

2. Procedures

2.1 Mechanical Property and Chemical Resistance Characterization of Al2519. The mechanical characterization was performed on the base alloy in different heat-treated conditions, as well as on weldments of the alloy to itself and to other aluminum alloys. Previous studies of this material have produced a limited database of material and weldment properties. This

program attempted to validate some of the previous data, as well as expand the information to include forgings and various weldments. The test matrix in Table 1 includes the following types of testing: (1) tensile tests at room temperature and 300 °F, (2) rotating beam (R. R. Moore) and dog bone fatigue tests, and (3) general corrosion, pitting corrosion, and stress corrosion cracking characterization. The various heat treatments and weldments of the material investigated included Al2519-T6 plate as a surrogate for T6 forgings, Al2519-T87 wrought base plate, weld joints for Al2519-T87 to itself using Al2319 filler wire, and weld joints for Al2519-T87 to Al2519-T6 forging using Al2219 filler wire. Not all tests were performed for each material configuration. Again, the goal was not to redevelop an Al2519 database, but only to fill the voids in the data and to verify the suppliers' ability to manufacture products similar to those in the past. Table 1 lists the quantities and orientations of the specimens evaluated as part of the mechanical and chemical resistance characterization.

The material configurations were representative of planned sections for the Al2519 hull structure in the Crusader self-propelled howitzer (SPH) and resupply vehicle (RSV). The weld joints were representative of those planned for the fabrication of this vehicle system. More detailed descriptions of each test are listed in the following sections. The mechanical and corrosion resistance portion of the program centered on evaluating four combinations of alloys and weldments. The mechanical testing was limited to both tensile and fatigue testing due to cost restrictions.

Multiple-pass automated gas metal arc welding (GMAW) was utilized in joining the weldments. These weldments were tested in two orientations. Longitudinal specimens were machined from a single-V joint weldment with the specimen axis parallel to the weld fusion line. This resulted in a specimen consisting primarily of weld metal, although the appearance of HAZ material might be possible, depending on the weldment and the machining. A schematic of the cross section of the single-V joint weldment is shown in Figure 1. Transverse tensile specimens were machined from an offset double-V joint across the weld, with the gauge section of the specimen containing base metal, HAZ, and weld metal. A schematic of the cross section of the double-V joint weldment is shown in Figure 2. Weldments were measured for yield strength

Table 1. Material Characterization Test Matrix for Al2519 Forgings, Plate, and Weldments

Test	Test Details	T6 Forging Surrogate	2519-T87 Base Plate	T87 to T87 Weldment	2519-T6 Weldment	2519-T87 to 2519-T6 Weldment	Test Standard
Tensile	Long.	6	—	6	2	ASTM-E-8 [3] and AWS-B-4.0 [4]	
	Transverse	6	—	6	—	ASTM-E-8 [3] and AWS-B-4.0 [4]	
	300 °F Long.	2	—	2	—	ASTM-E-8 [3] and AWS-B-4.0 [4]	
	300 °F Trans.	2	—	2	—	ASTM-E-8 [3] and AWS-B-4.0 [4]	
Fatigue	Round Long.	24	8	24 Weld Metal	—	ASTM-E-466 [5]	
	Round Trans.	24	8	24	—	ASTM-E-466 [5]	
	Dogbone	—	8	8 Trans.	—	—	
	After 100 hr Salt Fog - Round Bar	8	8	8 Trans.	—	ASTM-E-466 [5]	
General Corrosion	—	—	—	3	—	ASTM-G-34 [6] ASTM-G-112 [7]	
	—	3	—	3	—	ASTM-B-117 [8]	
Stress Corrosion Cracking	C-Ring	12	—	—	—	ASTM-G-38 [9] ASTM-G-47 [10]	
	Sandwich Specimen	—	—	3	3	ASTM-G-44 [11]	

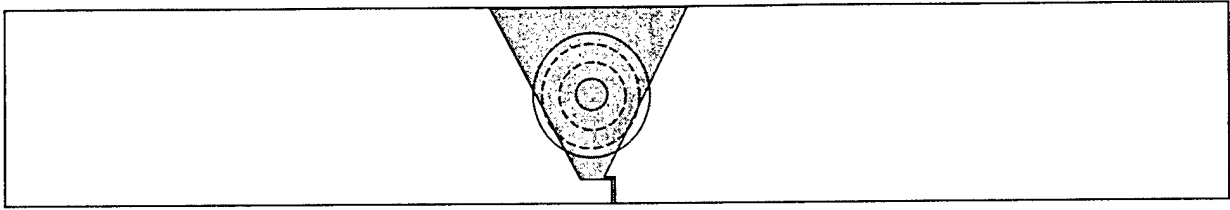

Figure 1. Single-V Joint Schematic With Longitudinal Specimen Orientation (Not to Scale).

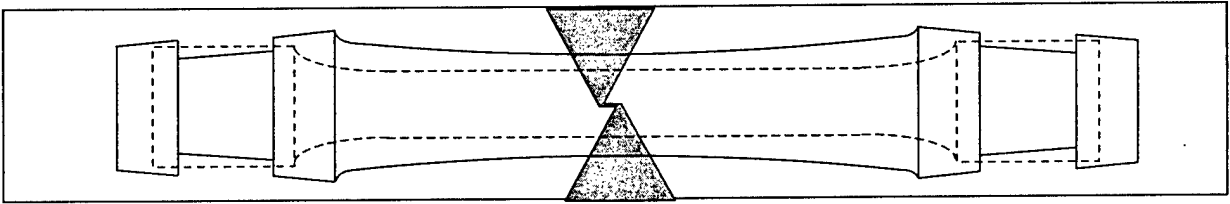

Figure 2. Double-V Joint Schematic With Transverse Specimen Orientation (Not to Scale).

(YS), ultimate tensile strength (UTS), percent elongation, and reduction in area (RA) in both directions. Longitudinal tensile elongation was recorded, although this is not a true measure of weldment ductility due to the nonhomogeneity of the specimen in that orientation. The critical measure of weldment ductility was evaluated under the ballistic shock portion of this work. Six room-temperature specimens from each orientation were tested for the Al2519-T87 weldment to itself, along with two elevated temperature tests. Two room-temperature tests were performed for the Al2519-T87 welded to the Al2519-T6 forging in the longitudinal direction, which isolated any ductility loss in the weld.

2.1.1 Tensile Testing. Tensile tests were performed according to established standards, such as ASTM-E-8 [3] and AWS-B-4.0 [4], for the Al2519-T6 forgings and weldments, respectively. Six specimens were tested for the forgings in each orientation, four at room temperature and two at 300 °F. Two samples were reserved as spares for each orientation. The tensile specimens were tested with full stress-strain to failure. The data acquired included YS, UTS, percent elongation and RA in the longitudinal and transverse orientations. Figure 3 shows a schematic of the tensile specimen utilized.

appropriate mathematical model was used to develop regression curves for the data. The equations derived to best fit the data are depicted on the individual plots. The base material data was verified and contrasted with the previously accepted values at two different stress levels. Bending fatigue data were also generated for these three materials after the specimens were exposed to a salt fog environment for 100 hr. This testing was performed in accordance with ASTM-B-117 [8], and it provided a measure for the effect of pitting on the fatigue life for these material configurations. A schematic of the rotating beam specimen utilized is depicted in Figure 4.

Axial fatigue values were generated using a rectangular dog-bone specimen for Al2519-T87 and weldments. The goal for this testing was to evaluate the entire throat of the welded structure, including both the cap and root passes. This type of testing provided information relative to the weld fatigue life that a machined round-bar specimen masks. The base material was tested to provide baseline values for this geometry. Four specimens were tested at two stress levels. S-N curves were derived from the acquired data. An appropriate mathematical model was used to develop regression curves for the data. The equations derived to best fit the data are depicted on the individual plots. Schematics of the axial tensile specimen utilized are shown in Figures 5 and 6 for the unwelded and welded specimens, respectively. Specimens were obtained from the welded plates, as depicted in Figure 7.

2.1.3 General Corrosion. Three coupons of Al2519-T87 welded to itself were immersed in a solution of 4.0-M NaCl, 0.5-M KCl, and 0.1-M nitric acid for 96 hr as per ASTM-G-34 [6]. Samples were examined after 4, 24, 48, 72, and 96 hr of exposure. Several panels of base material were evaluated through leveraged efforts of other ARL programs.

2.1.4 Pitting Corrosion. Coupons of Al2519-T6 forging surrogate and Al2519 T87-T87 weldments were exposed to a 5% NaCl solution for 1,000 hr per ASTM-B-117 [8]. Coupons were examined following 1, 10, 100, 400, and 1,000 hr of exposure for pitting. Following exposure, coupons were cleaned and re-examined.

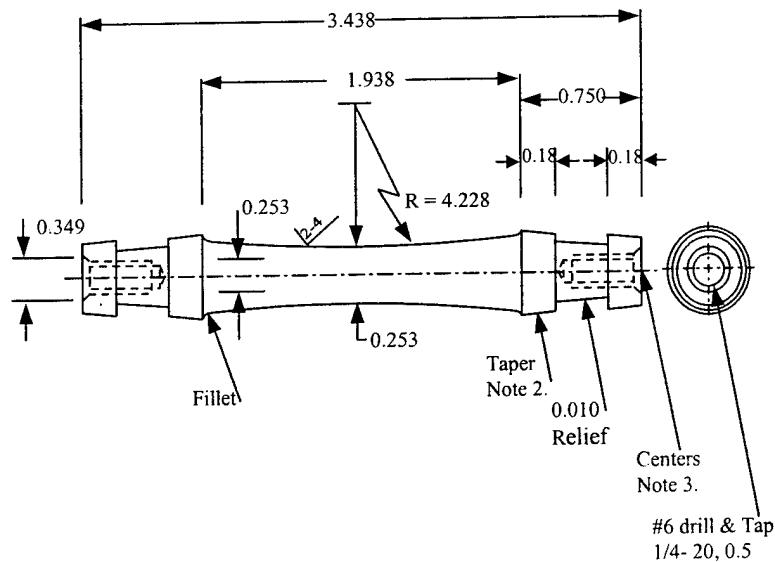

- Notes: (1) Dimensions in inches.
 (2) Radius may be changed depending on gage length.
 (3) Taper $0.625 \pm 0.005/\text{ft}$ on diameter.
 (4) Centers for turning, use 60° included angle center with maximum diameter of center, 0.344 ± 0.005 diameter.
 (5) $1/4 - 20$ tapped holes must be concentric to outside diameter within 0.002 TIR.
 (6) All outside diameters. Must be concentric to center line and to each other within 0.0005 TIR.

Figure 4. Rotating-Beam (R. R. Moore) Specimen Schematic.

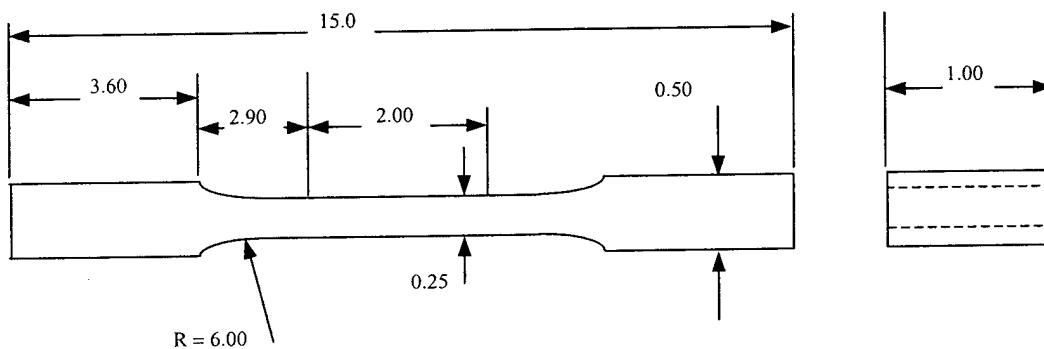

- Notes: (1) Dimensions in inches.
 (2) Tolerances, unless noted.
 Squareness \perp Perpendicular ± 0.001 TIR
 \parallel Parallel ± 0.001 TIR
 (3) Fractions $\pm 1/64$
 (4) Decimal X.XX ± 0.005
 X.XXX ± 0.001
 X.XXXX ± 0.0005

Figure 5. Axial Fatigue Specimen for Unwelded Base Material.

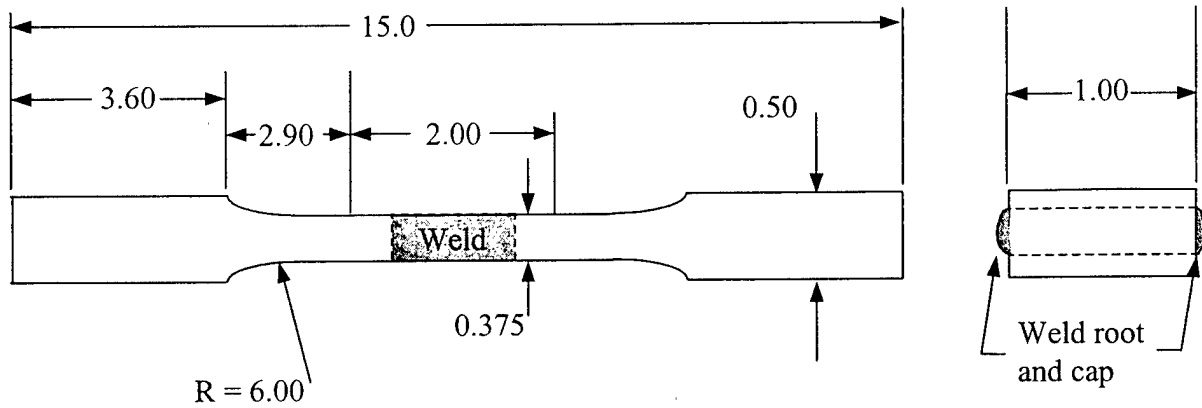

- Notes: (1) Dimensions in inches.
 (2) Tolerances, unless noted.
 Squareness \perp Perpendicular ± 0.001 TIR
 \parallel Parallel ± 0.001 TIR
 (3) Fractions $\pm 1/64$
 (4) Decimal X.XX ± 0.005
 X.XXX ± 0.001
 X.XXXX ± 0.0005

Figure 6. Axial Fatigue Specimen for Welded Material.

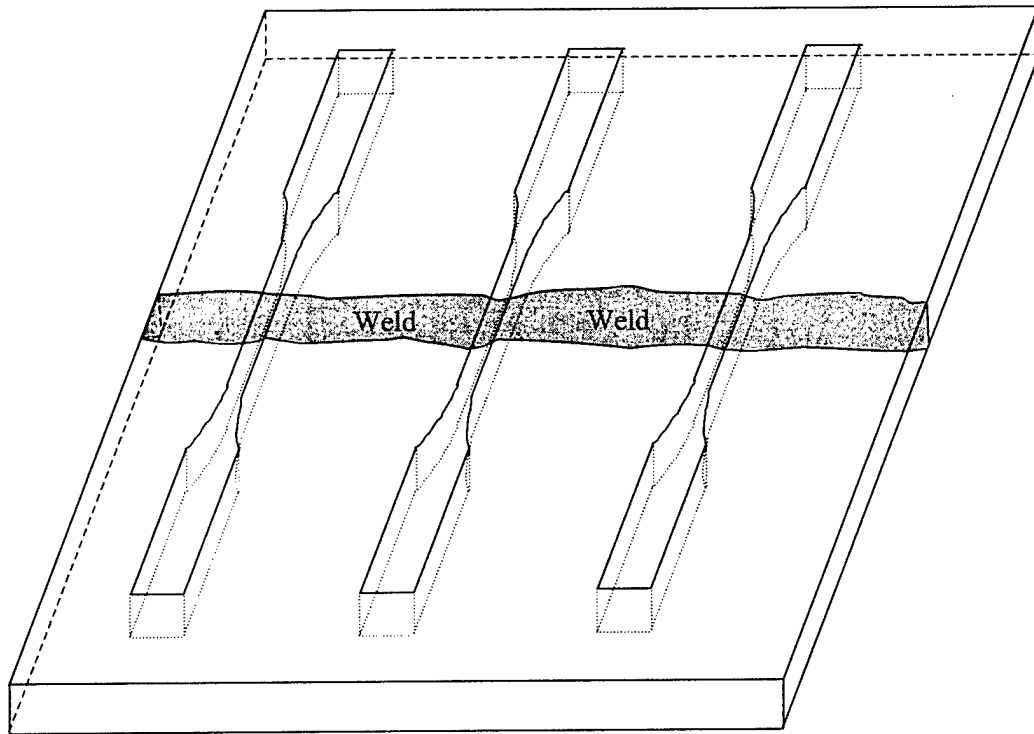

Figure 7. Welded-Plate Axial Fatigue Specimen Orientation.

2.1.5 Stress Corrosion Cracking. Twelve samples from Al2519-T6 forgings were evaluated for SCC susceptibility. C-ring specimens were produced according to ASTM-G-38 [9] and alternately immersed in 3.5% sodium chloride solution, as specified in ASTM-G-47 [10]. A schematic of the C-ring specimen is shown in Figure 8. Both weldment configurations (T87-T87 and T87-T6) were evaluated for SCC behavior in accordance with ASTM-G-44 [11] using a sandwich weldment specimen. This specimen geometry simulates a rigid structure; when it is subjected to a corrosive environment, it provides a screening test for SCC. GDLS performed all welding. A schematic of the sandwich weldments is depicted in Figure 9.

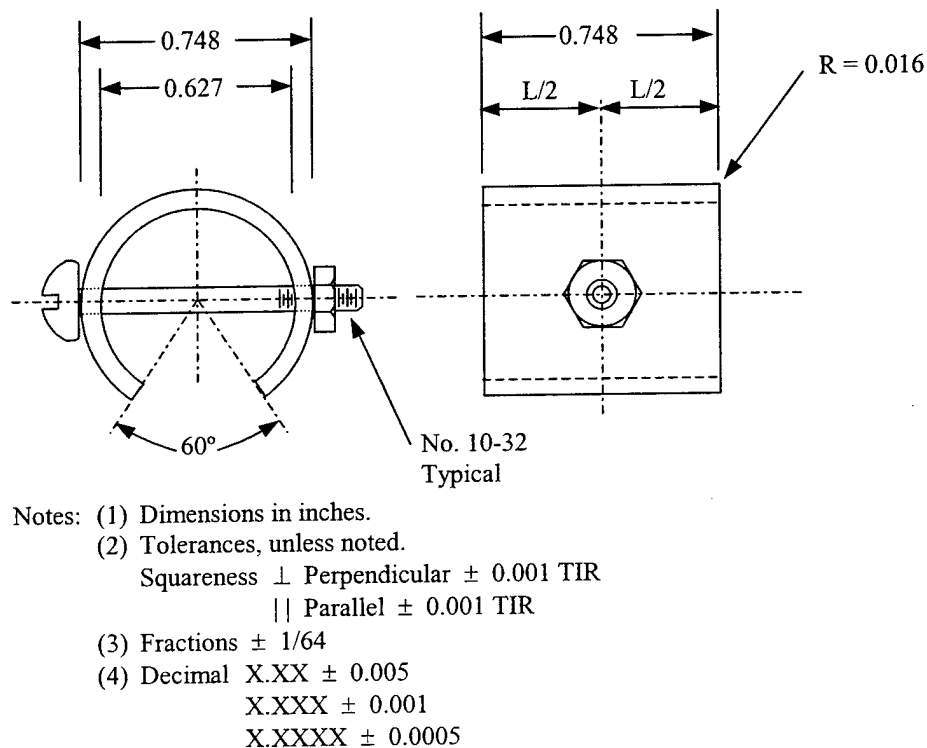
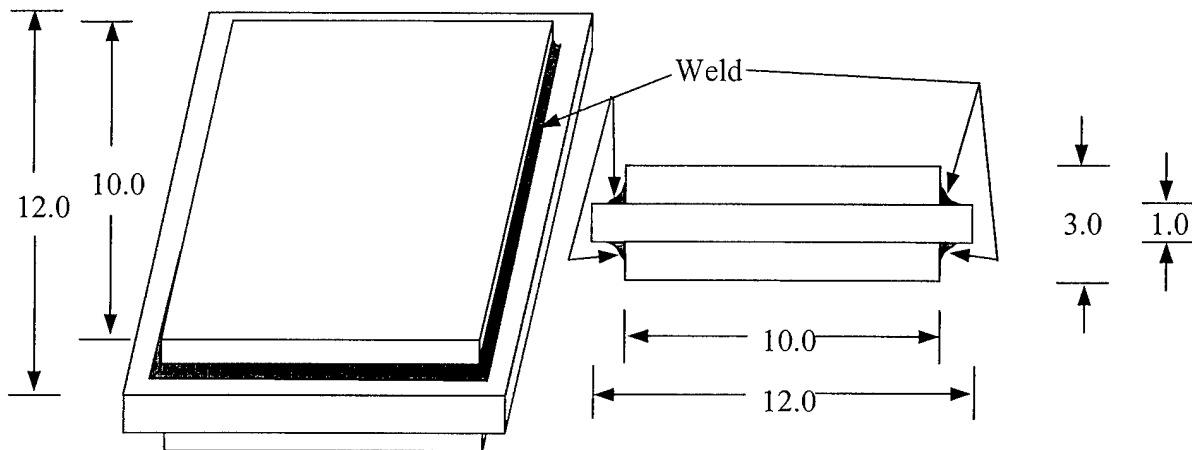

Figure 8. SCC C-Ring Specimen Schematic.

2.2 Ballistic Characterization of Al2519 Plate and Welds. The objectives for this portion of the work package were threefold.

- (1) Standardize the base plate dimensions for the ballistic shock test used for determining the critical velocity, that is to be subsequently used to calculate striking velocities for the



- Notes: (1) Dimensions in inches.
 (2) Tolerances, unless noted.
 Squareness \perp Perpendicular ± 0.001 TIR
 Parallel \parallel Parallel ± 0.001 TIR
 (3) Fractions $\pm 1/64$
 (4) Decimal X.XX ± 0.005
 X.XXX ± 0.001
 X.XXXX ± 0.0005

Figure 9. SCC Sandwich Specimen Schematic.

weldment specimens. The critical velocity is defined as the velocity above which the base plate will sustain a crack of 12 inches or greater when subjected to the aluminum-proofing projectile at a certain confidence level. The striking velocity is the acceptance velocity for the qualification of weldments. Traditionally, this is calculated by taking 90% of the critical velocity for the base plate. However, for Al2519, the lack of weld ductility caused weldment failures at this velocity. A minimum of four ballistic tests were to be performed on each of seven different plates. The seven thicknesses planned were 0.50, 0.625, 0.75, 0.875, 1.00, 1.25, and 1.50 inches.

- (2) Develop a ballistic property database for plate thicknesses of 0.50, 0.625, 0.75, 0.875, and 1.00 in. This information was used to obtain striking velocities (acceptance qualification) for both 57-mm and 75-mm projectiles. The 75-mm projectile is depicted in Figures 10 and 11. A minimum of five thicknesses with 12 ballistic tests per thickness was planned for testing. The intention of this testing was to verify the weld procedure, not the appropriateness of specific weld designs for the vehicle structure.



Figure 10. Disassembled 75-mm Aluminum Projectile.

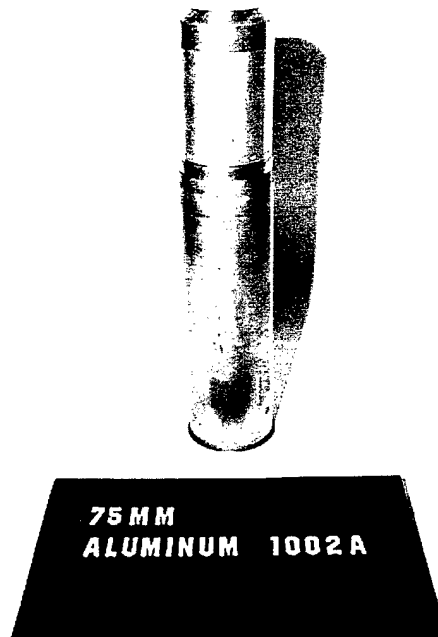

Figure 11. Assembled 75-mm Aluminum Projectile.

(3) Expand the ballistic limit acceptance data for thicker sections of Al2519. Thicknesses were tested against 0.50-cal. armor-piercing (AP) M2 and 14.5-mm armor-piercing incendiary (API) BS41 threats. Plate thicknesses were 1.50, 2.25, 3.00, 3.50, and 4.00 in. The data developed by these tests were used to expand the ballistic acceptance tables of MIL-DTL-46192 [2].

Ideally, the development of the specification curves for Al2519 requires three different manufacturers, each providing three lots of material in three different thicknesses within the two thickness ranges previously discussed. This is the minimum sample size to address lot-to-lot and manufacturer-to-manufacturer variances. This amounts to 54 ballistic-limit data points. The test matrix is shown in Table 2.

Table 2. Ballistic Curve Development Table

No. of Plates Required			Plate Thickness (in)	Obliquity (°)	Threat Projectile
Supplier A	Supplier B	Supplier C			
3	3	3	1.50	0	0.50-cal. AP M2
3	3	3	2.25	0	0.50-cal. AP M2
3	3	3	3.00	0	0.50-cal. AP M2
3	3	3	3.00	0	14.5-mm BS 41
3	3	3	3.50	0	14.5-mm BS 41
3	3	3	4.00	0	14.5-mm BS 41

The ballistic limit for each of the data points needs to be determined by the method of maximum likelihood from 12 test rounds fired in accordance with the Langlie method. An appropriate mathematical model was used to develop a regression curve, where the values of the constants in the curve were determined using the method of least squares. The curve was then utilized to generate the tables in Appendix A. The minimum acceptable ballistic limit requirements were then set to reject 5% of the plates submitted for “first time” lot-acceptance testing.

3. Testing and Results

3.1 Mechanical Property and Chemical Resistance Characterization of Al2519.

3.1.1 Tensile Testing. The tensile strength and elongation data for the T87-T87 and T87-T6 weldments and the T6 alloy are presented in Tables 3–5, respectively. The specimen number indicates an “L” for those specimens machined in the longitudinal direction, and a “T” for those machined in the transverse direction.

3.1.2 Fatigue Testing. The R. R. Moore rotating beam and axial fatigue test data for the T87-T87 weldment and the T87 and T6 alloy base plate are presented in Tables 6–10, respectively. The corresponding graphs are presented in Figures 12–14, respectively. The 100-hr salt-fog-exposed specimens for the T87-T87 weldment, the T87 base alloy, and the T6 surrogate are depicted in Figures 15–17, respectively. The surface details of these respective figures are presented in Figures 18–20.

3.1.3 General Corrosion. After 5 hr of exposure to the sodium chloride, potassium chloride, and nitric acid solution, all three T87-T87 coupons had small bubbles effervescing from the surface and had caused the solution to cloud. There was less activity at the weld. Upon closer inspection, the ends of the coupon had darkened, while the weld and heat-affected zone remained bright. The welding material was Al2319 for these weld configurations.

The reaction slowed significantly, and a reddish-brown scale formed on the nonweld portions of the coupon after 24 hr. The scale appeared to be loosely adherent. Although bubbles formed on the welded portions of the coupons, these areas remained bright.

After 48 hr, the weld began to tarnish, while a reddish product formed in the heat-affected zone. The reddish-brown exfoliant continued to form on the rest of the coupon. The panels' appearance changed only slightly after 72 hr. There was more of the reddish product on the weld and in the heat-affected zones, and more of the reddish-brown exfoliant than previously observed.

Table 3. Tensile and Elongation Data for the T87-T87 Weldments

Sample No.	Temperature (°F)	UTS (ksi)	0.2% YS (ksi)	4D/5D Elongation (%)	RA (%)	Ult. Load (lb)	0.2% Load (lb)	Orig. Gauge (in)	Final Gauge (in)	Orig. Area (in ²)
L1	R.T.	42.4	19.7	18.5/17.2	26.8	8,523	3,960	2/2.5	2.37/2.93	0.433
L2	R.T.	42.7	19.9	20.5/16.4	33.7	8,590	3,999	2/2.5	2.41/2.91	0.412
L3	R.T.	42.1	19.7	15.5/13.6	18.1	8,405	3,930	2/2.5	2.31/2.84	0.456
L4	R.T.	40.9	20.0	10.0/9.6	14.1	8,201	4,003	2/2.5	2.20/2.74	0.468
L5	R.T.	41.0	19.5	11.0/10.0	16.3	8,239	3,919	2/2.5	2.22/2.75	0.463
L6	R.T.	42.5	20.3	19.0/17.6	32.7	8,548	4,075	2/2.5	2.38/2.94	0.415
L7	300	34.1	19.0	22.0/19.2	20.6	6,836	3,800	2/2.5	2.44/2.98	0.450
L8	300	34.8	18.5	23.0/20.0	32.1	7,007	3,717	2/2.5	2.46/3.00	0.417
T1	R.T.	43.5	26.0	6.0/4.8	23.0	8,754	5,221	2/2.5	2.12/2.62	0.444
T2	R.T.	44.1	27.1	5.0/4.4	21.6	8,862	5,453	2/2.5	2.10/2.61	0.448
T3	R.T.	43.0	26.8	4.0/3.2	15.9	8,644	5,386	2/2.5	2.08/2.58	0.464
T4	R.T.	43.9	26.8	5.0/4.0	23.4	8,821	5,387	2/2.5	2.10/2.6	0.443
T5	R.T.	44.2	29.0	5.0/4.8	27.1	8,886	5,837	2/2.5	2.10/2.62	0.432
T6	R.T.	43.8	28.7	5.0/4.4	25.8	8,816	5,765	2/2.5	2.10/2.61	0.436
T7	300	35.6	25.4	6.5/5.2	33.7	7,168	5,107	2/2.5	2.13/2.63	0.412
T8	300	36.0	26.0	7.0/5.6	33.4	7,216	5,198	2/2.5	2.14/2.64	0.412

Table 4. Tensile and Elongation Data for the T87-T6 Weldments

Sample No.	Temperature	UTS (ksi)	0.2% YS (ksi)	4D Elongation (%)	RA (%)	Ult. Load (lb)	0.2% Load (lb)	Orig. Gauge (in)	Final Gauge (in)	Orig. Area (in ²)
L1	R.T.	42.1	19.8	15	18.1	8,424	3,968	2.0	2.30	0.200
L2	R.T.	42.1	20.2	18	30.2	8,437	4,046	2.0	2.36	0.200

Table 5. Tensile and Elongation Data for the T6 Alloy

Sample No.	Temperature	UTS (ksi)	0.2% YS (ksi)	4D Elongation (%)	RA (%)	Ult. Load (lb)	0.2% Load (lb)	Orig. Gauge (in)	Final Gauge (in)	Orig. Area (in ²)
L1	R.T.	63.5	51.0	11.0	25.0	12,460	10,020	2.0	2.22	0.196
L2	R.T.	63.5	48.2	11.5	23.6	12,440	9,469	2.0	2.23	0.196
L3	R.T.	64.0	48.5	13.5	18.6	12,520	9,519	2.0	2.27	0.196
L4	R.T.	63.5	47.9	10.5	24.7	12,440	9,402	2.0	2.21	0.196
L5	R.T.	63.5	48.8	11.5	19.4	12,470	9,589	2.0	2.23	0.196
L6	R.T.	63.5	48.7	11.5	20.1	12,500	9,566	2.0	2.23	0.196
L7	300	52.5	44.6	13.0	44.3	10,280	8,752	2.0	2.26	0.196
L8	300	52.0	44.4	14.0	38.8	10,170	8,709	2.0	2.22	0.196
T1	R.T.	65.0	51.0	10.0	24.3	12,740	10,040	2.0	2.20	0.196
T2	R.T.	64.5	48.2	10.5	23.6	12,650	9,469	2.0	2.21	0.196
T3	R.T.	64.5	48.2	10.0	21.5	12,650	9,466	2.0	2.20	0.196
T4	R.T.	64.5	48.3	10.0	16.1	12,690	9,493	2.0	2.20	0.196
T5	R.T.	64.5	49.2	10.5	22.6	12,690	9,664	2.0	2.21	0.196
T6	R.T.	65.0	49.7	11.0	24.7	12,750	9,761	2.0	2.22	0.196
T7	300	52.0	46.1	13.5	49.0	10,210	9,058	2.0	2.27	0.196
T8	300	52.0	47.5	14.0	48.4	10,220	9,321	2.0	2.28	0.196

Table 6. R. R. Moore Rotating-Beam Fatigue Data for the T87-T87 Weldments

Sample No.	Measured Diameter (in)	Maximum Stress (ksi)	Maximum Load (lb)	Cycles to Failure	Failure Location	Machining Direction
RRMT5	0.2508	18	13.9	2,936,929	gauge	transverse
RRMT7	0.2512	18	14.0	969,744	gauge	transverse
RRMT15	0.2514	18	14.0	7,148,000	gauge	transverse
RRMT16	0.2515	18	14.1	7,304,500	gauge	transverse
RRMT2	0.2515	20	15.6	8,418,000	gauge	transverse
RRMT13	0.2513	20	15.6	1,269,811	gauge	transverse
RRMT19	0.2515	20	15.6	573,321	gauge	transverse
RRMT22	0.2514	20	15.6	912,835	gauge	transverse
RRMT3	0.2514	22	17.2	335,995	gauge	transverse
RRMT10	0.2515	22	17.2	997,618	gauge	transverse
RRMT11	0.2515	22	17.2	329,098	gauge	transverse
RRMT12	0.2513	22	17.1	2,202,291	gauge	transverse
RRMT4	0.2514	24	18.7	247,000	gauge	transverse
RRMT14	0.2513	24	18.7	916,000	gauge	transverse
RRMT17	0.2517	24	18.8	169,932	gauge	transverse
RRMT18	0.2517	24	18.8	371,001	gauge	transverse
RRMT1	0.2515	28	21.9	50,000	gauge	transverse
RRMT8	0.2513	28	21.8	108,388	gauge	transverse
RRMT9	0.2515	28	21.9	122,291	gauge	transverse
RRMT21	0.2515	28	21.9	106,980	gauge	transverse
RRMT20	0.2514	32	25.0	0	gauge	omitted for fit
RRMT6	0.2145	16	12.5	10,000,000	discontinued	omitted for fit
RRMT23	0.2507	16	12.4	10,000,000	discontinued	omitted for fit
RRMT24	0.2510	16	12.4	10,000,000	discontinued	omitted for fit
RRML22	0.2515	18	14.1	1,873,000	gauge	longitudinal
RRML23	0.2515	18	14.1	7,887,000	gauge	longitudinal
RRML8	0.2522	20	15.7	1,996,000	gauge	longitudinal
RRML9	0.2512	20	15.6	6,801,000	gauge	longitudinal
RRML19	0.2519	20	15.7	2,728,000	gauge	longitudinal
RRML24	0.2513	20	15.6	1,311,000	gauge	longitudinal
RRML2	0.2516	22	17.2	1,403,000	radius	longitudinal
RRML3	0.2514	22	17.2	361,394	radius	longitudinal
RRML13	0.2513	22	17.1	727,000	gauge	longitudinal
RRML17	0.2513	22	17.1	402,804	gauge	longitudinal
RRML1	0.2511	24	18.7	520,000	gauge	longitudinal
RRML10	0.2521	24	18.9	324,850	gauge	longitudinal
RRML14	0.2521	24	18.9	453,490	gauge	longitudinal

Table 6. R. R. Moore Rotating-Beam Fatigue Data for the T87-T87 Weldments (Continued)

Sample No.	Measured Diameter (in)	Maximum Stress (ksi)	Maximum Load (lb)	Cycles to Failure	Failure Location	Machining Directions
RRML11	0.2513	28	21.8	124,858	gauge	longitudinal
RRML15	0.2519	28	22.0	148,651	gauge	longitudinal
RRML18	0.2520	28	22.0	209,000	gauge	longitudinal
RRML21	0.2514	28	21.8	182,000	gauge	longitudinal
RRML7	0.2514	30	23.4	53,841	gauge	longitudinal
RRML12	0.2520	30	23.6	60,074	gauge	longitudinal
RRML16	0.2518	30	23.5	64,968	gauge	longitudinal
RRML20	0.2520	30	23.6	32,128	gauge	longitudinal
RRML6	0.2516	24	18.8	62,000	gauge, at pit	omitted for fit
RRML4	0.2513	18	14.0	10,000,000	discontinued	omitted for fit
RRML5	0.2516	18	14.1	10,000,000	discontinued	omitted for fit
SF8	0.2511	10	7.8	1,664,000	radius	salt fog
SF1	0.2514	14	10.9	1,787,000	gauge	salt fog
SF4	0.2515	14	10.9	2,884,156	radius	salt fog
SF3	0.2517	18	14.1	715,000	gauge	salt fog
SF7	0.2514	18	14.0	614,563	radius	salt fog
SF2	0.2512	22	17.1	127,000	gauge	salt fog
SF5	0.2513	22	17.1	118,000	gauge	salt fog
SF6	0.2513	10	7.8	10,000,000	discontinued	omitted for fit

Table 7. Axial Fatigue Data for the T87-T87 Weldments

Sample No.	Area (in ²)	Alternating Stress (ksi)	Alternating Load (lb)	Cycles to Failure	Failure Location	Machining Direction
7	0.380135	8	3,062	396,875	HAZ	axial transverse
8	0.380135	8	3,041	507,906	HAZ	axial transverse
6	0.380058	8	3,040	729,311	HAZ	axial transverse
5	0.381542	12.5	4,769	76,363	HAZ	axial transverse
3	0.379197	12.5	4,740	99,662	HAZ	axial transverse
4	0.380844	12.5	4,761	123,254	HAZ	axial transverse
2	0.380691	20	7,614	12,843	HAZ	axial transverse
1	0.380807	20	7,616	25,355	HAZ	axial transverse

Table 8. R. R. Moore Rotating-Beam Fatigue Data for the T87 Alloy

Sample No.	Measured Diameter (in)	Maximum Stress (ksi)	Maximum Load (lb)	Cycles to Failure	Failure Location	Machining Direction
RRML2	0.2511	24	18.7	7,294,789	radius	transverse
RRML8	0.2517	25	19.6	10,269,000	gauge	transverse
RRML4	0.2516	26	20.3	4,240,530	gauge	transverse
RRML1	0.2513	30	23.4	3,645,000	gauge	transverse
RRML7	0.2517	32	25	521,873	gauge	transverse
RRML5	0.2521	34	26.7	272,991	gauge	transverse
RRML3	0.252	23	18.1	10,000,000	discontinued	omitted for fit
RRML6	0.2511	28	21.8	10,000,000	discontinued	omitted for fit
RRML5	0.2516	20	15.6	16,324,210	gauge	longitudinal
RRML4	0.2518	22	17.2	7,952,762	gauge	longitudinal
RRML3	0.252	24	18.9	2,540,137	gauge	longitudinal
RRML2	0.2519	26	20.4	2,845,067	gauge	longitudinal
RRML6	0.2518	28	21.9	1,699,000	gauge	longitudinal
RRML1	0.2519	30	23.5	958,373	gauge	longitudinal
RRML7	0.2522	32	25.2	665,235	gauge	longitudinal
RRML8	0.2518	35	27.4	258,781	gauge	longitudinal
RRML13	0.251	12	9.3	1,294,593	gauge	salt fog
RRML15	0.2513	12	9.3	1,306,231	gauge	salt fog
RRML11	0.2517	14	11	1,033,263	gauge	salt fog
RRML16	0.2526	16	12.7	416,195	gauge	salt fog
RRML10	0.2517	18	14.1	429,938	gauge	salt fog
RRML9	0.2516	22	17.2	235,876	gauge	salt fog
RRML12	0.2518	10	7.8	10,000,000	discontinued	omitted for fit
RRML14	0.2516	10	7.8	10,000,000	discontinued	omitted for fit

Table 9. Axial Fatigue Data for the T87 Alloy

Sample No.	Area (in ²)	Alternating Stress (ksi)	Alternating Load (lb)	Cycles to Failure	Failure Location	Machining Direction
5	0.256327	20	5,126	507,410	gauge	axial transverse
6	0.255898	20	5,118	771,152	gauge	axial transverse
4	0.256431	20	5,129	1,683,041	gauge	axial transverse
3	0.254518	25	6,363	210,508	gauge	axial transverse
1	0.253763	25	6,344	248,905	gauge	axial transverse
2	0.254114	25	6,353	309,240	gauge	axial transverse
7	0.256325	18	4,614	5,000,000	discontinued	omitted for fit
8	0.248759	18	4,478	336,386	gauge	omitted for fit

Table 10. R. R. Moore Rotating-Beam Fatigue Data for the T6 Alloy

Sample No.	Measured Diameter (in)	Maximum Stress (ksi)	Maximum Load (lb)	Cycles to Failure	Failure Location	Machining Direction
RRMT13	0.2502	20	15.4	8,700,000	radius	transverse
RRMT5	0.2517	22	17.2	6,873,000	gauge	transverse
RRMT6	0.2518	22	17.2	8,521,207	gauge	transverse
RRMT20	0.2512	22	17.1	4,355,394	gauge	transverse
RRMT20	0.2515	24	18.7	2,514,000	gauge	transverse
RRMT12	0.2515	24	18.7	5,178,984	gauge	transverse
RRMT15	0.2517	24	18.8	6,297,909	gauge	transverse
RRMT22	0.2516	24	18.8	3,827,000	gauge	transverse
RRMT4	0.2516	28	21.9	1,663,000	gauge	transverse
RRMT10	0.2511	28	21.8	1,671,000	gauge	transverse
RRMT19	0.2519	28	22	972,412	gauge	transverse
RRMT24	0.2518	28	21.9	1,383,000	gauge	transverse
RRMT3	0.2519	30	23.5	767,162	gauge	transverse
RRMT8	0.2518	30	23.5	894,000	gauge	transverse
RRMT11	0.2514	30	23.4	717,796	gauge	transverse
RRMT21	0.2515	30	23.4	864,000	gauge	transverse
RRMT9	0.2518	34	26.6	209,762	gauge	transverse
RRMT14	0.2513	34	26.5	302,000	gauge	transverse
RRMT18	0.2518	34	26.6	360,600	gauge	transverse
RRMT23	0.2514	34	26.5	199,000	gauge	transverse
RRMT1	0.2515	20	15.6	10,000,000	discontinued	omitted for fit
RRMT7	0.2517	20	15.7	10,000,000	discontinued	omitted for fit
RRMT16	0.2511	20	15.5	10,000,000	discontinued	omitted for fit
RRMT17	0.2518	22	17.2	10,000,000	discontinued	omitted for fit
RRML7	0.2515	20	15.6	12,266,000	gauge	longitudinal
RRML3	0.2513	22	17.1	9,987,000	gauge	longitudinal
RRML6	0.2513	22	17.1	11,178,000	radius	longitudinal
RRML15	0.2515	22	17.2	3,877,955	gauge	longitudinal
RRML1	0.2514	24	18.7	5,855,614	gauge	longitudinal
RRML4	0.2517	24	18.8	2,312,000	gauge	longitudinal
RRML13	0.2517	24	18.8	4,649,175	gauge	longitudinal
RRML5	0.2517	28	21.9	954,126	gauge	longitudinal
RRML9	0.2511	28	21.8	1,832,000	gauge	longitudinal
RRML18	0.2514	28	21.8	1,326,000	gauge	longitudinal
RRML22	0.2518	28	21.9	670,606	gauge	longitudinal
RRML23	0.2519	32	25.1	459,000	gauge	longitudinal

Table 10. R. R. Rotating-Beam Fatigue Data for the T6 Alloy (Continued)

Sample No.	Measured Diameter (in)	Maximum Stress (ksi)	Maximum Load (lb)	Cycles to Failure	Failure Location	Machining Direction
RRML8	0.2517	34	26.6	581,000	gauge	longitudinal
RRML10	0.2517	34	26.6	269,000	gauge	longitudinal
RRML12	0.2513	34	26.5	533,000	gauge	longitudinal
RRML14	0.2515	34	26.5	391,000	gauge	longitudinal
RRML2	0.2518	36	28.2	290,332	gauge	longitudinal
RRML16	0.2513	36	28	280,299	gauge	longitudinal
RRML19	0.2515	36	28.1	228,850	gauge	longitudinal
RRML24	0.2517	36	28.2	263,820	gauge	longitudinal
RRML17	0.2515	20	15.6	10,000,000	discontinued	omitted for fit
RRML20	0.2515	20	15.6	10,000,000	discontinued	omitted for fit
RRML21	0.2518	20	15.7	10,000,000	discontinued	omitted for fit
SF2	0.2528	5.5	4.4	6,389,163	gauge	salt fog
SF4	0.2517	10	7.8	2,490,747	radius	salt fog
SF1	0.2519	14	11	733,759	gauge	salt fog
SF3	0.2525	18	14.2	349,542	gauge	salt fog
SF8	0.2525	22	17.4	191,016	gauge	salt fog
SF5	0.2525	5	4	10,000,000	discontinued	omitted for fit
SF6	0.2527	5	4	10,000,000	discontinued	omitted for fit

The corrosion panels were photographed in situ, immediately upon removal, and with some of the corrosion product removed. The removed crystals were either white, reddish brown (when wet), or black. The corrosion product turned either white or black upon drying. Coupons were chemically cleaned and photographed. An example of the general corrosion coupons after chemical cleaning is shown in Figure 21.

The coupons completed the exposure with an exfoliation rating of “EA” per ASTM-G-34 [6], although the damage to the samples appears to be due to severe general corrosion and pitting. This assessment was performed after the corrosion product was removed and the surface was cleaned. The chemically cleaned surface is depicted in Figure 21. Exposed surfaces were evenly degraded through pitting. Significantly less material was removed from the welds and the heat-affected zones.

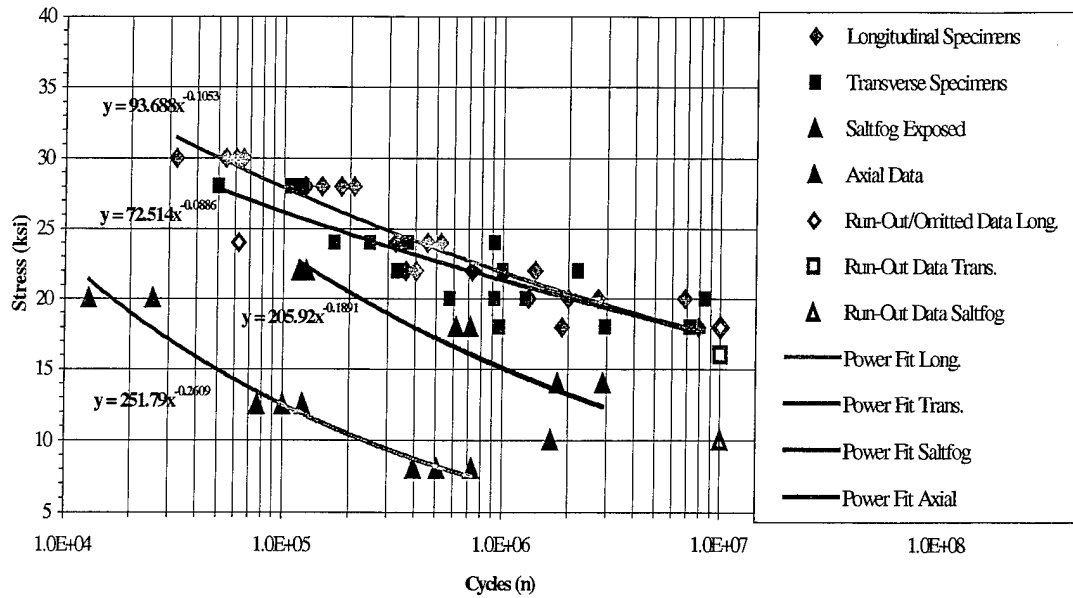

Figure 12. Rotating Beam and Axial Fatigue Data for the T87-T87 Weldment, R-Ratio = -1, Kt = 1.

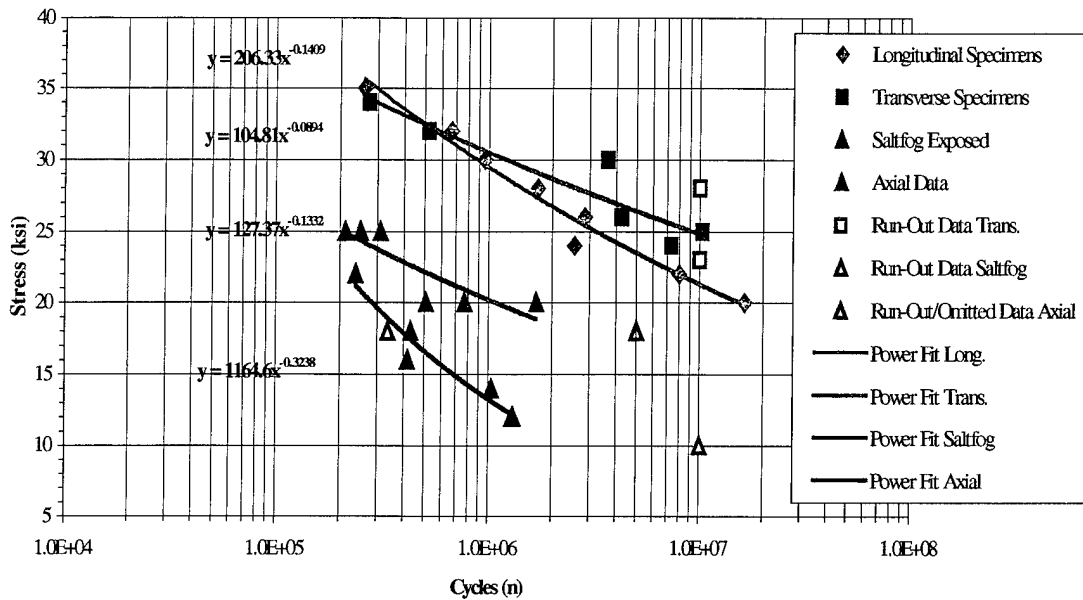

Figure 13. Rotating Beam and Axial Fatigue Data for the T87 Base Plate, R-Ratio = -1, Kt = 1.

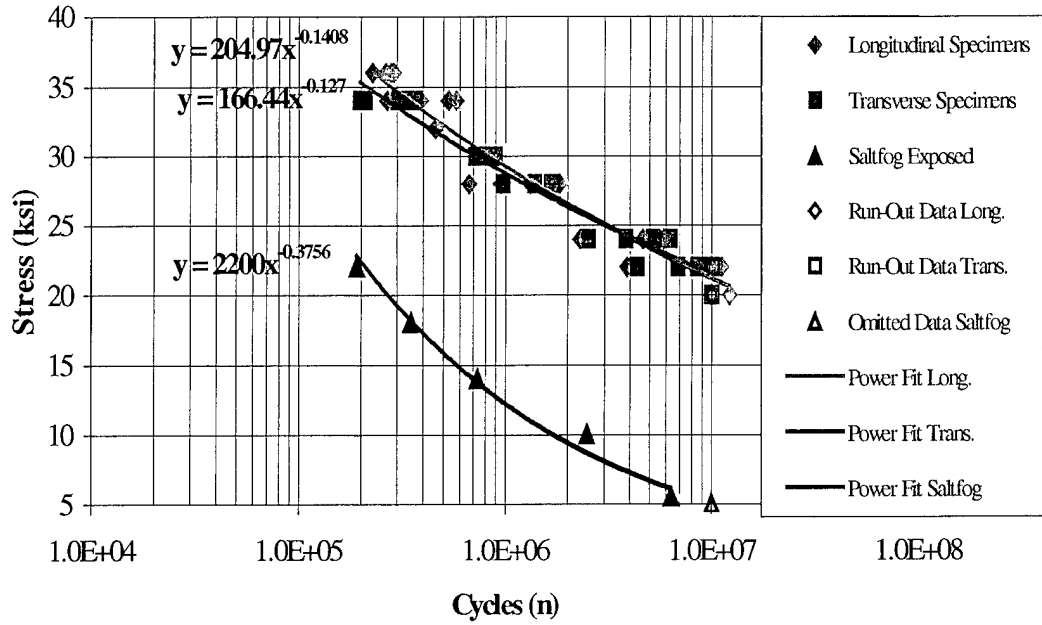

Figure 14. Rotating Beam and Axial Fatigue Data for the T6 Surrogate, R-Ratio = -1, Kt = 1.

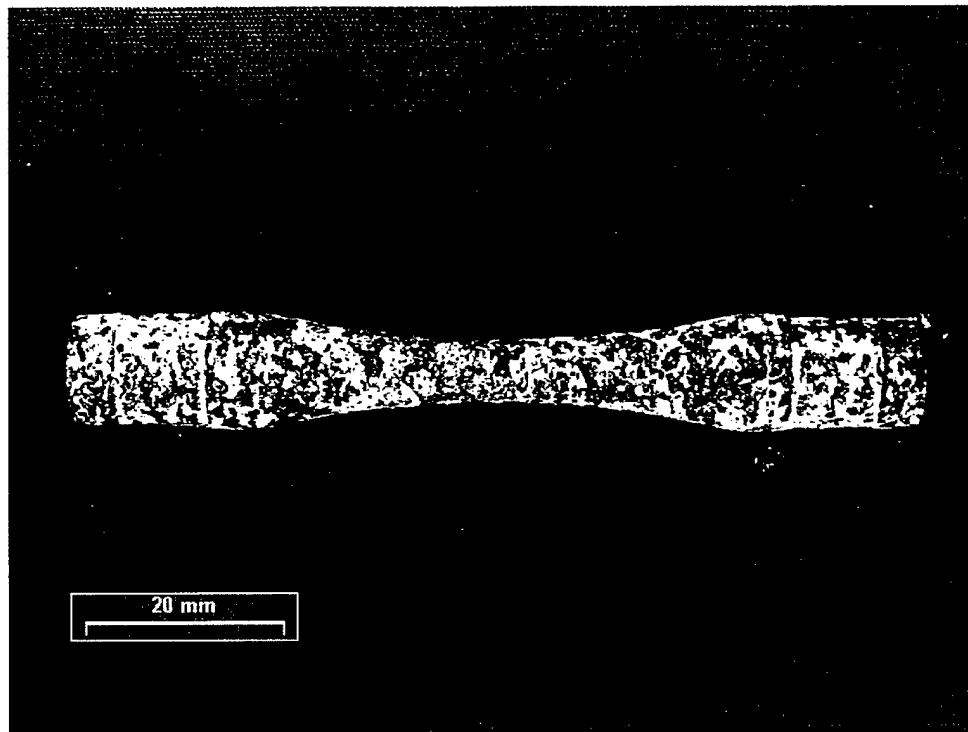

Figure 15. T87-T87 100-Hr Salt-Fog-Exposed R. R. Moore Specimen.

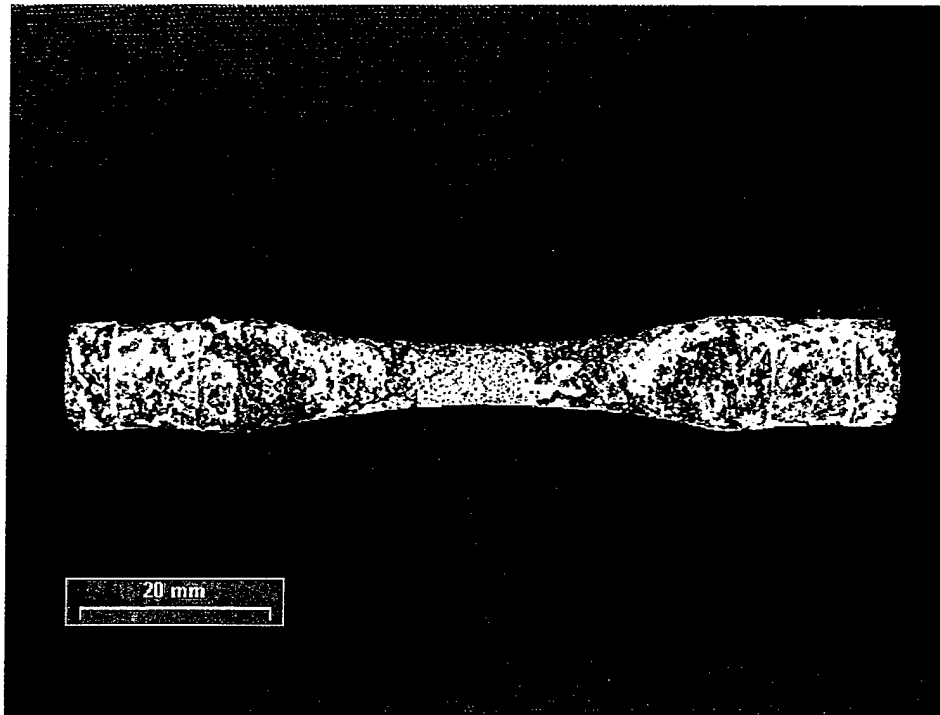

Figure 16. T87 Base Alloy 100-Hr Salt-Fog-Exposed R. R. Moore Specimen.

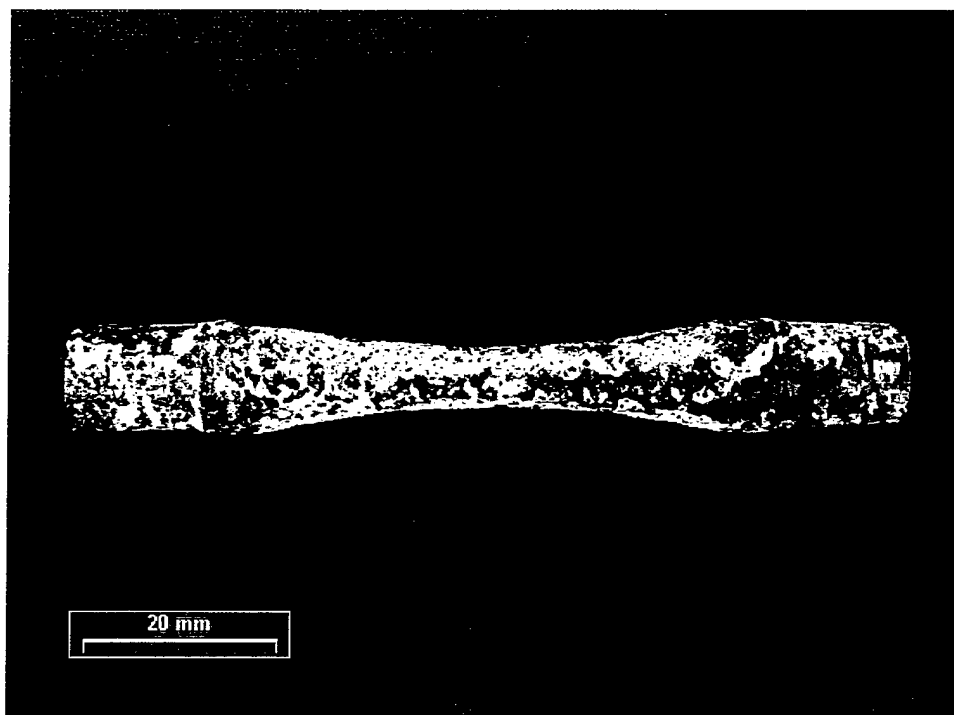

Figure 17. T6 Surrogate 100-Hr Salt-Fog-Exposed R. R. Moore Specimen.



Figure 18. Surface Detail of T87-T87 100-Hr Salt-Fog-Exposed R. R. Moore Specimen (Magnification 15 \times).

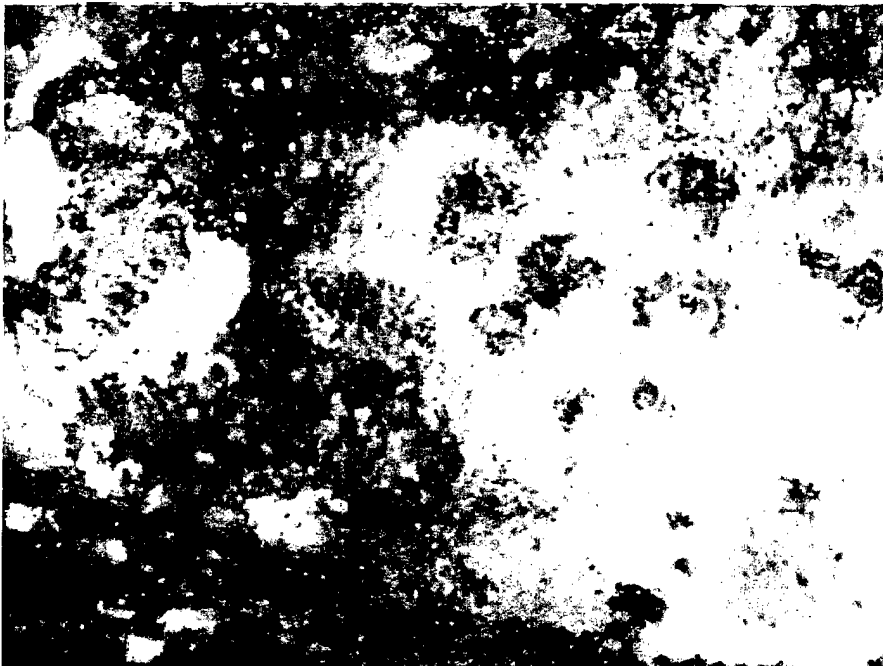

Figure 19. Surface Detail of T87 Base Alloy 100-Hr Salt-Fog-Exposed R. R. Moore Specimen (Magnification 15 \times).

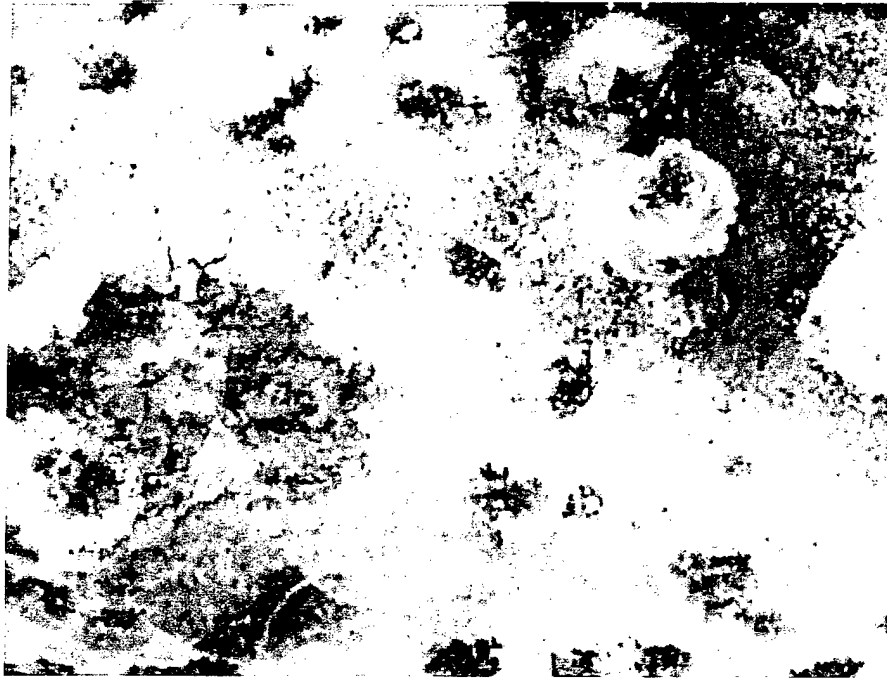

Figure 20. Surface Detail of T6 Surrogate 100-Hr Salt-Fog-Exposed R. R. Moore Specimen (Magnification 15 \times).

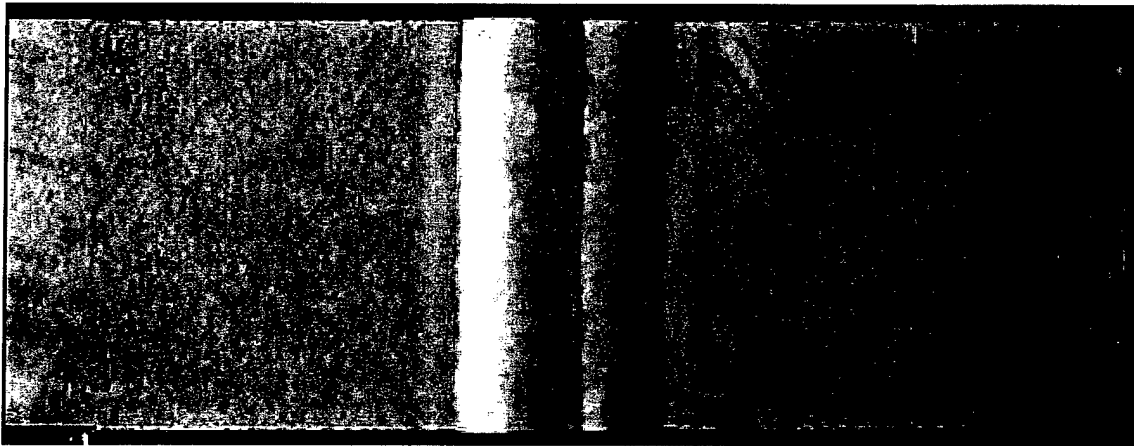

Figure 21. T87-T87 With 2319 Filler Metal Corrosion Specimen After Chemical Cleaning.

3.1.4 Pitting Corrosion. The Al2519-T6 panels were slightly discolored and streaked after 1 hr of salt-fog exposure. After 10 hr, all three coupons had corrosion product (aluminum hydroxide gel) coating the surface with scattered pits. An additional 90 hr of exposure caused

the corrosion product to become thicker with rivulets. The pits became larger and more abundant. The pits tended to have the same reddish-brown product as noted in the ASTM-G-34 [6] test. The appearance of the panels at 400 and 1,000 hr was remarkably similar. Rivulets of white aluminum hydroxide gel flowed down the coupons emanating from pit sites. Corrosion product coated the entire surface; no basis metal was visible. Upon cleaning, it was found that there was substantial pitting across the surface, which was surrounded by areas of relatively unaffected material. An example of a T6 pitting corrosion specimen is depicted in Figure 22.

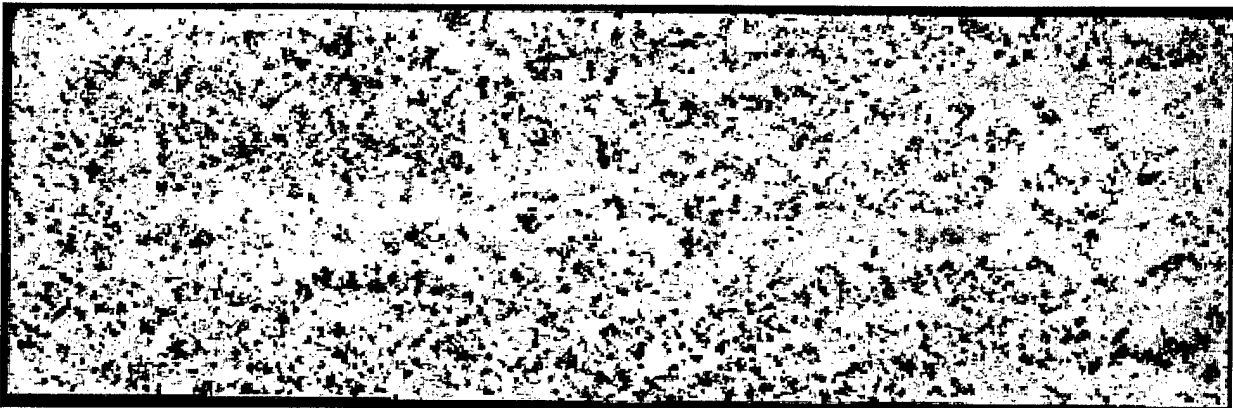

Figure 22. T6 Corrosion Specimen After Chemical Cleaning.

The bulk material of the Al2519 T87-T87 welded coupons behaved in a similar manner to the Al2519-T6. However, the weld and HAZs behaved somewhat differently. After 1 hr of exposure, the welded areas remained bright; the welds started to corrode after 10 hr, but were not affected as severely as the milled finishes of the coupons. At 100 hr of exposure, small pits developed on the welds; the pits on the welds were fewer and smaller than on the bulk material. After both 400 and 1,000 hr, the only discernable difference between the welded areas and the bulk material was that the deposits of corrosion product were thinner than on the rest of the coupon. The coupons were then chemically cleaned. An example of the chemically cleaned specimens can be observed in Figure 23. A surface profilometer was used to compare the pitting on each type of sample. The results from the profilometer indicated that the heat-affected zone was slightly less susceptible to corrosion than the bulk material.



Figure 23. T87-T87 With 2319 Filler Metal Corrosion Specimen After Chemical Cleaning.

The ASTM-B-117 [8] test demonstrated that Al2519 was susceptible to general corrosion and pitting. This susceptibility is not positively or negatively affected by the presence of a weld.

3.1.5 Stress Corrosion Cracking. The SCC testing was carried out according to ASTM-G-38 [9], ASTM-G-47 [10], and G-44 [11]. The six welded sandwiches and the 10 C-ring specimens were exposed for 10 days. Figures 24 and 25 represent the sandwiches and C-rings within the test chamber after 1-day and 10-day exposures, respectively.

After removal from the test chamber, the specimens were scrubbed with a soft bristle brush under running water to remove salt and corrosion product. The test specimens are shown in Figures 26 and 27. All specimens were then examined under approximately 10× magnification to determine whether SCC was present. Specimens were wetted with distilled water and wiped with a paper towel to facilitate the inspection. No SCC was observed on any of the specimens. Details of the sandwich specimens and the C-rings can be observed in Figures 28 and 29, respectively.

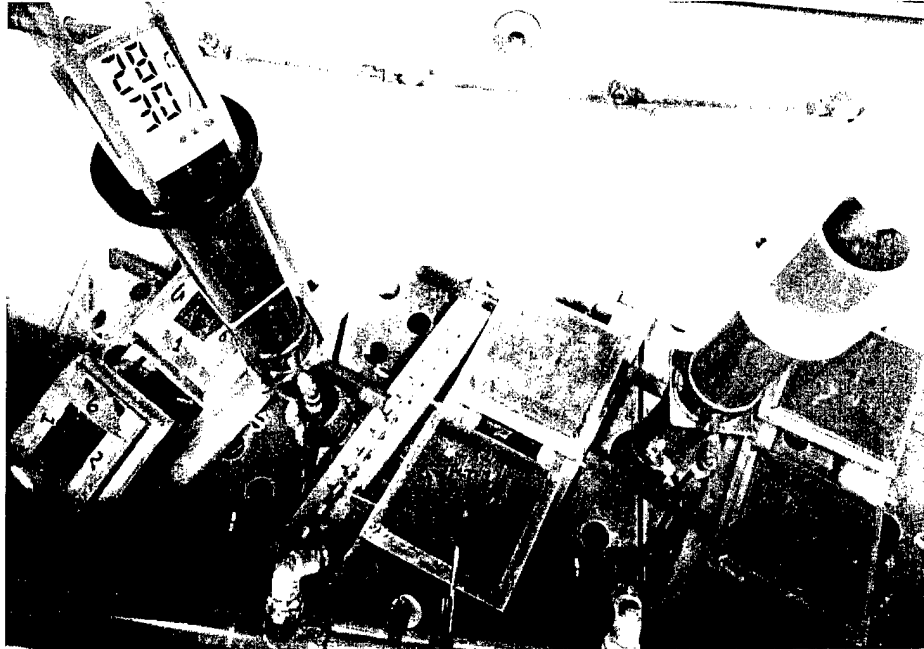

Figure 24. C-Rings and Sandwich Specimens After One Day of Salt-Fog Exposure.

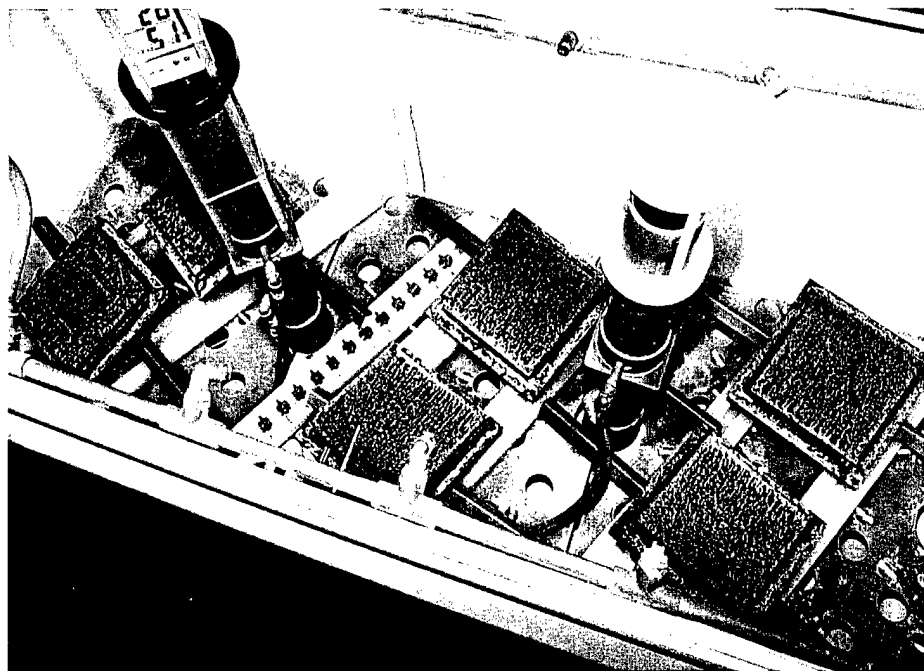

Figure 25. C-Rings and Sandwich Specimens After 10 Days of Salt-Fog Exposure.

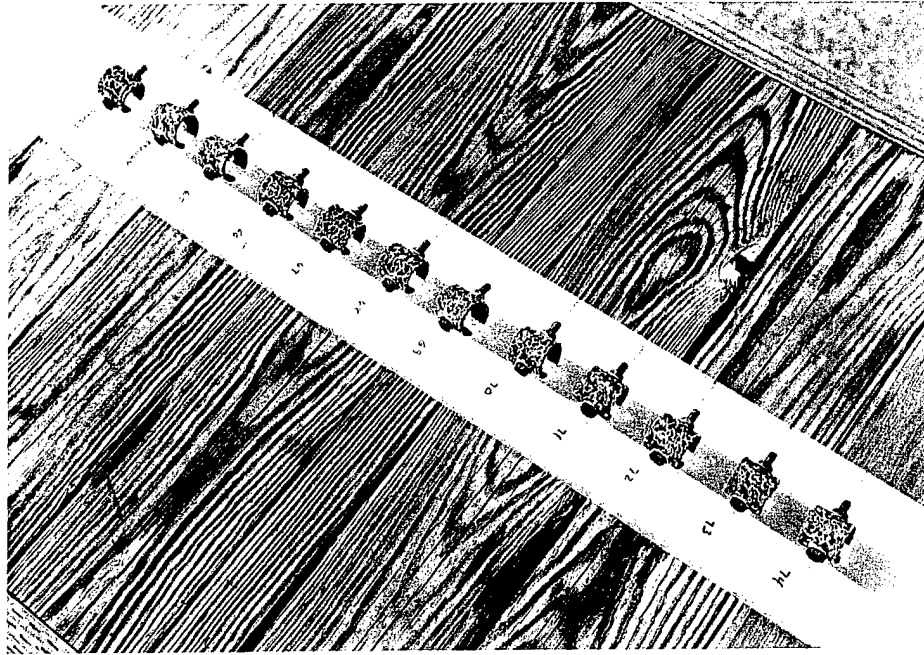

Figure 26. Cleaned C-Ring Specimens After 10 Days of Salt-Fog Exposure.

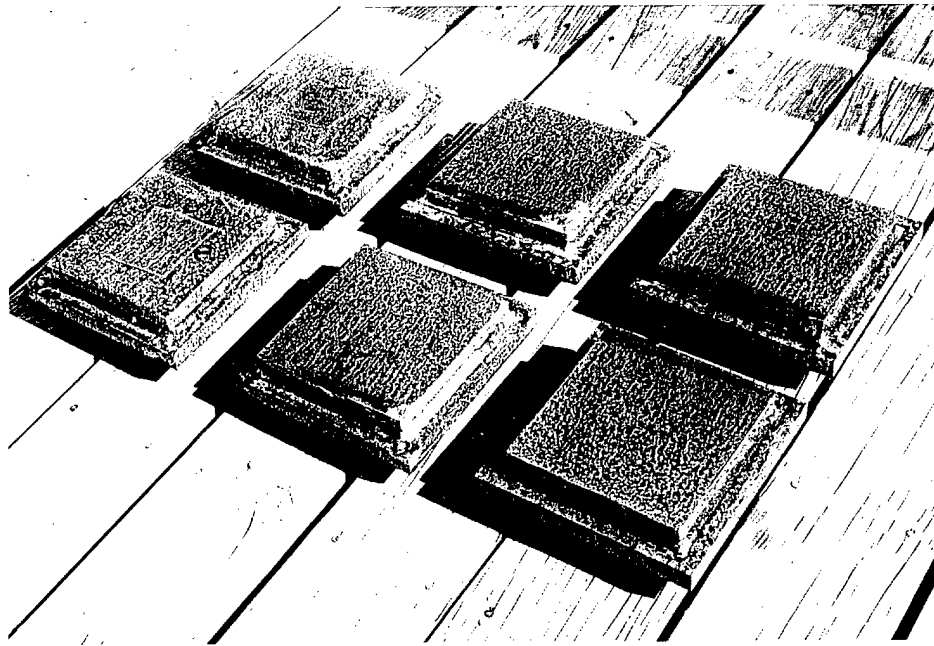

Figure 27. Cleaned Sandwich Specimens After 10 Days of Salt-Fog Exposure.

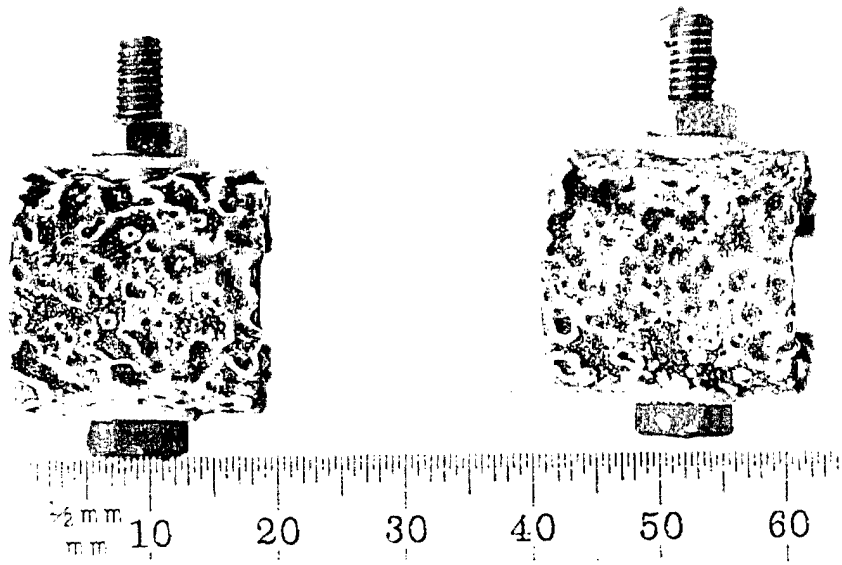

Figure 28. Details of Cleaned C-Ring Specimens After 10 Days of Salt-Fog Exposure.

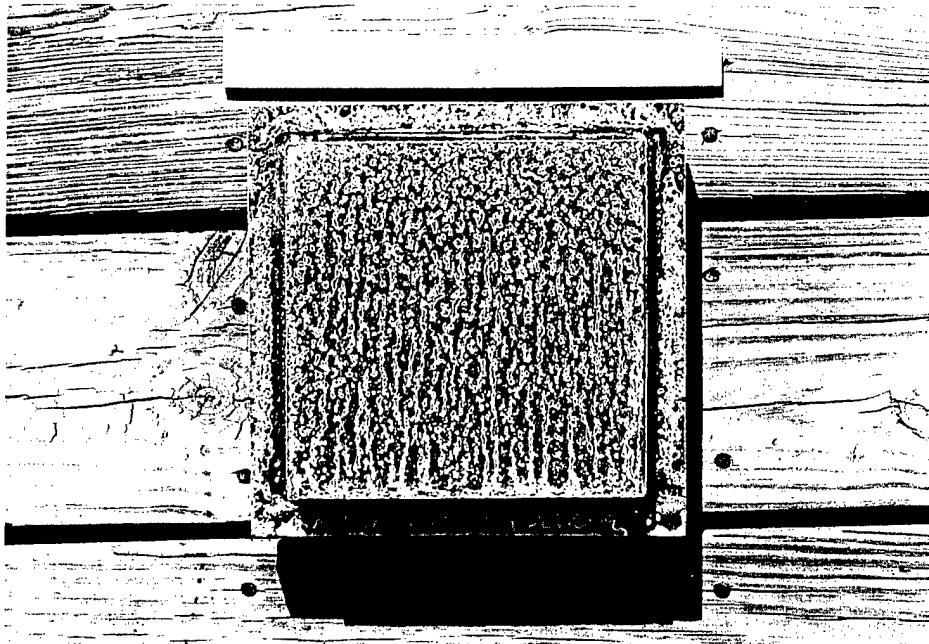

Figure 29. Details of Cleaned Sandwich Specimen After 10 Days of Salt-Fog Exposure.

3.2 Ballistic Characterization of Al2519 Plate and Welds. The development of the acceptance criteria (striking velocities) for weldments was not completed. Not all of the plates and weldments required to complete this effort were supplied. However, some data were generated with the 75-mm proofing projectile (and various test shots). Unfortunately, the results of the ballistic testing and the resulting minimum required striking velocity ballistic limits calculated from this data are not statistically acceptable for the U.S. Army to publish or use for the acceptance of weldments because of the limited number of plates provided. The results and the corresponding calculated ballistic limits are presented in Tables 11 and 12, respectively. Figures 30–35 depict the typical results from the 75-mm proofing projectile firings. The photographs can be identified and cross-referenced using the shot number listed in Table 11. No results were generated with the 57-mm proofing projectile, and only three shots were taken. The lack of required plates and weldments of Al2519 proved deleterious to this ballistic effort. Additionally, the OPM Crusader's decision to change the hull material to Al5083 (MIL-DTL-46027 [12]) halted the effort. The memorandum dated 23 June 1999 from UDLP [13], Armament Systems, stated that the Team Crusader requested all work using Al2519 to stop immediately in order to begin the hull transition effort with Al5083. However, since some of the Al2519 material was available, along with a balance of the funding, it was decided to attempt to complete the two ballistic efforts for potential future use of the material. Obviously, the handbook that was to be written to replace MIL-STD-1946 [1] will not be completed. Also, the minimum required ballistic limits that were developed could not be used for acceptance testing due to a lack of statistical confidence in the data. Future testing with both projectiles and the specified number of plates and weldments will be required.

The second ballistic effort to expand the ballistic-limit acceptance data for thicker sections of Al2519 was completed. The data developed by these tests were used to augment the ballistic acceptance tables in MIL-DTL-46192 [2]. To develop these two ballistic acceptance tables, numerous rounds of both the 0.50-cal. AP M2 and 14.5 API BS41 needed to be shot. Appendix B contains the results of the individual test shots (complete or partial). V_{50} velocities were generated from the shot data and are tabulated individually in Table 13. An appropriate mathematical model was used to develop a regression curve. The curve was then utilized to

Table 11. Striking Velocity Data

Plate Thickness (mm)	Projectile (mm)	Shot No.	Velocity	Result	Remarks
15	57	15-1-1	1,692	crack	Broke a large section of plate off
15	57	15-1-2	1,249	crack	—
15	57	15-2-1	1,043	crack	—
25	—	—	—	—	—
30	75	30-1-1	1,369	crack	—
	75	30-2-1	1,128	crack	—
	75	30-3-1	928	bent plate	—
	75	30-3-2	1,029	bent plate	—
	75	30-4-1	1,069	bent plate	—
	75	30-4-2	1,078	bent plate	—
	75	30-5-1	1,165	crack	—
35	75	35-1-1	1,396	crack	—
	75	35-2-1	1,342	crack	—
	75	35-3-1	1,308	crack	—
	75	35-4-1	1,290	crack	—
	75	35-5-1	1,234	bent plate	—
	75	35-5-2	1,264	crack	—
40	75	40-1-1	1,425	crack	Inverted “Y” crack, 20 in total
	75	40-2-1	1,439	crack	Plate cracked in half
	75	40-3-1	1,388	crack	Plate cracked in half, pieces held together
	75	40-3-2	1,348	crack	Disregard
50	75	50-1-1	1,411	dented plate	—
	75	50-1-2	1,520	dented plate	—
	75	50-2-1	1,630	dented plate	—
	75	50-2-2	1,838	dented plate	Projectile material limit

generate the tables in Appendix A. The values of the constants in the regression curve were determined using the method of least squares.

The minimum acceptable ballistic limit requirements were then set to reject 5% of the plates submitted for first time lot-acceptance testing. The resulting ballistic data tables are identified as Tables 14–15. As mentioned previously, these tables should be incorporated into

Table 12. Minimum Required Striking Velocity Ballistic Limits

Thickness (in)	Required (BL(P),FPS)	Thickness (in)	Required (BL(P),FPS)	Thickness (in)	Required (BL(P),FPS)	Thickness (in)	Required (BL(P),FPS)
0.975	541	1.130	745	1.285	908	1.440	1049
0.980	549	1.135	751	1.290	913	1.445	1053
0.985	556	1.140	756	1.295	918	1.450	1057
0.990	563	1.145	762	1.300	923	1.455	1061
0.995	571	1.150	768	1.305	927	1.460	1066
1.000	578	1.155	773	1.310	932	1.465	1069
1.005	585	1.160	779	1.315	937	1.470	1074
1.010	592	1.165	785	1.320	941	1.475	1078
1.015	599	1.170	790	1.325	946	1.480	1082
1.020	607	1.175	796	1.330	951	1.485	1086
1.025	613	1.180	801	1.335	956	1.490	1090
1.030	620	1.185	806	1.340	960	1.495	1094
1.035	626	1.190	812	1.345	965	1.500	1098
1.040	634	1.195	817	1.350	969	1.505	1103
1.045	640	1.200	823	1.355	974	1.510	1106
1.050	647	1.205	827	1.360	978	1.515	1111
1.055	653	1.210	833	1.365	983	1.520	1114
1.060	660	1.215	838	1.370	987	1.525	1119
1.065	666	1.220	843	1.375	992	1.530	1122
1.070	672	1.225	849	1.380	996	1.535	1127
1.075	679	1.230	853	1.385	1001	1.540	1130
1.080	685	1.235	859	1.390	1005	1.545	1135
1.085	691	1.240	864	1.395	1010	1.550	1139
1.090	698	1.245	869	1.400	1014	1.555	1142
1.095	704	1.250	874	1.405	1019	1.560	1147
1.100	709	1.255	878	1.410	1022	1.565	1150
1.105	716	1.260	884	1.415	1027	1.570	1154
1.110	722	1.265	888	1.420	1031	1.575	1158
1.115	727	1.270	894	1.425	1036	1.580	1162
1.120	734	1.275	898	1.430	1040	1.585	1166
1.125	739	1.280	904	1.435	1044	1.590	1170
—	—	—	—	—	—	1.595	1174
—	—	—	—	—	—	1.600	1177

Note: Minimum Required Ballistic Limits—75 mm, M1002a Aluminum Plate Proofing Projectile vs. 2519 Aluminum Welds at 0° Obliquity: Based on 90% of Base Armor Standard.



Figure 30. 75-mm Projectile Test Firing 30-1-1.



Figure 31. 75-mm Projectile Test Firing 30-2-1.

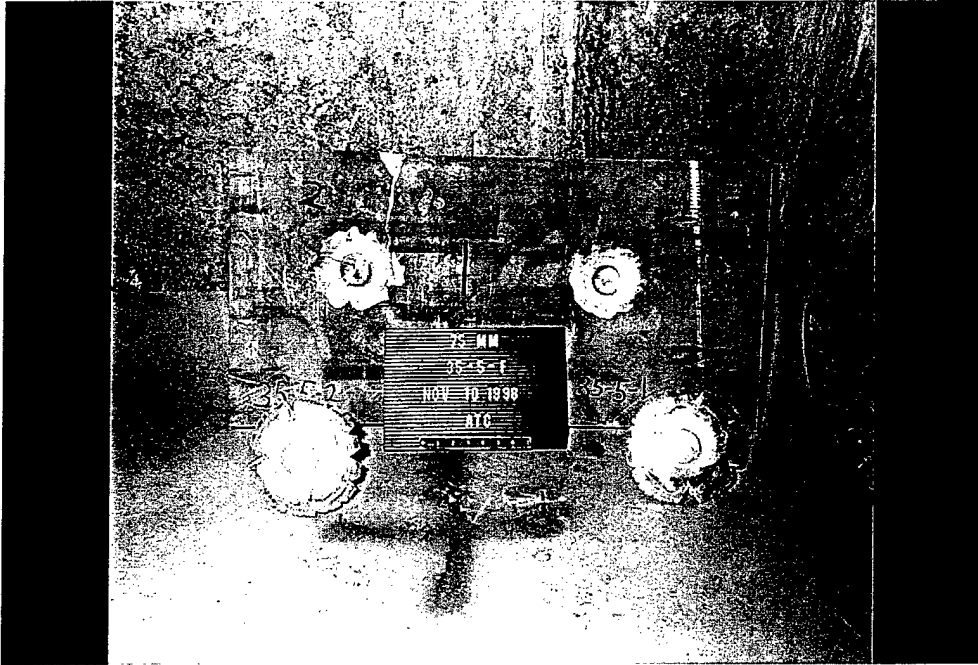

Figure 32. 75-mm Projectile Test Firing 35-5 After Both Shots (Front).

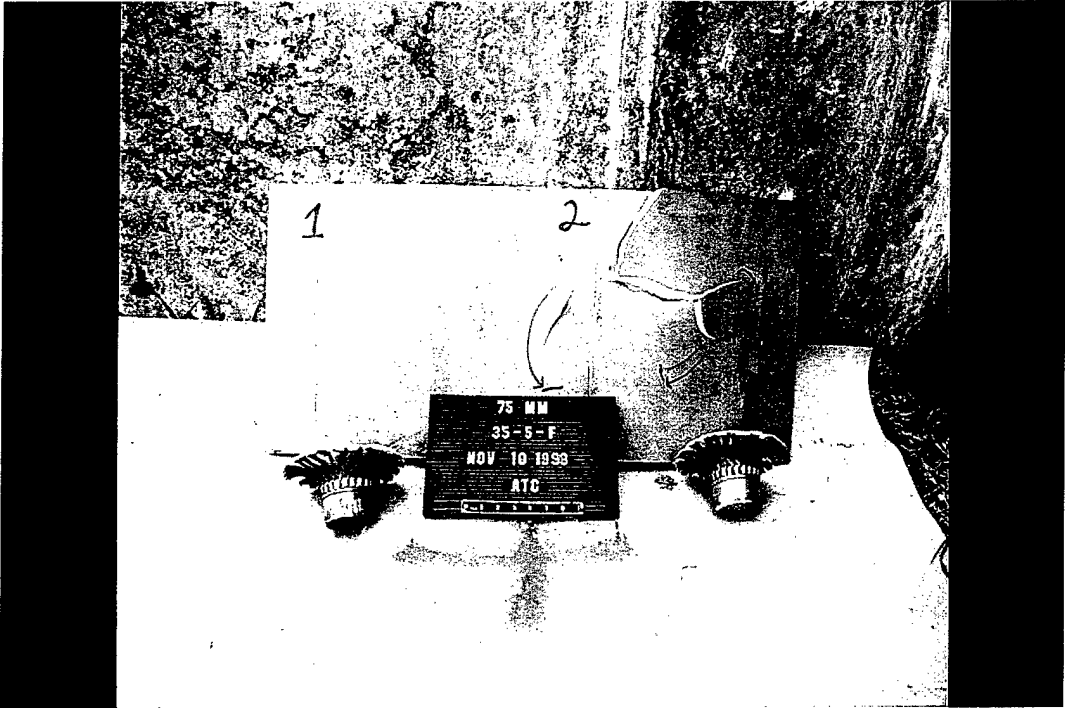

Figure 33. 75-mm Projectile Test Firing 35-5 After Both Shots (Back).

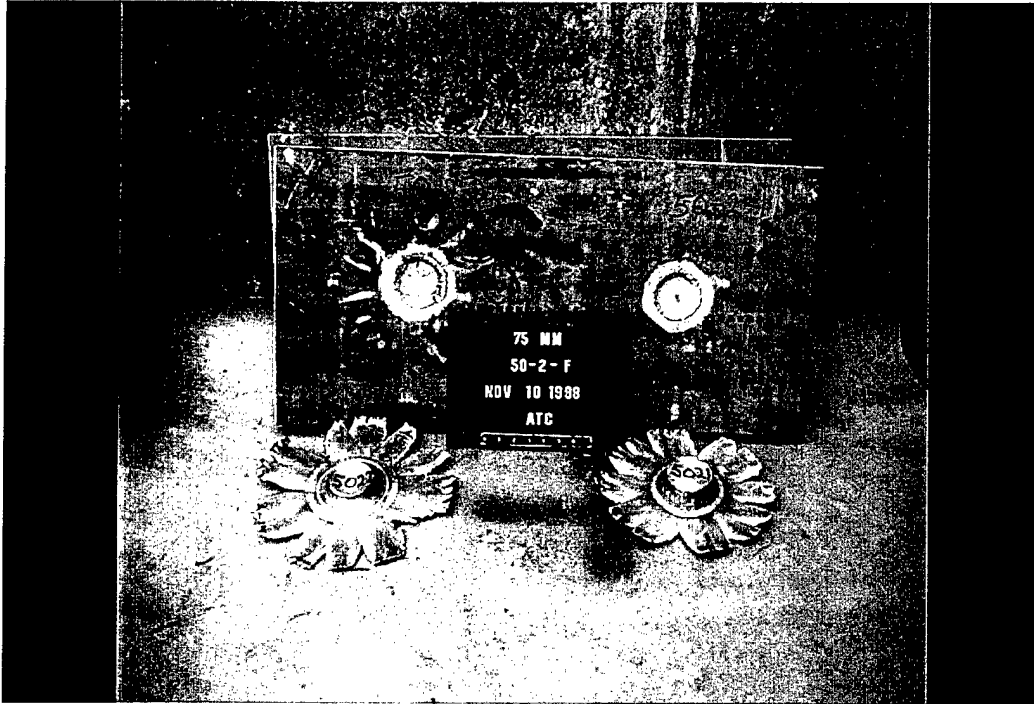

Figure 34. 75-mm Projectile Test Firing 50-2 After Both Shots (Front).

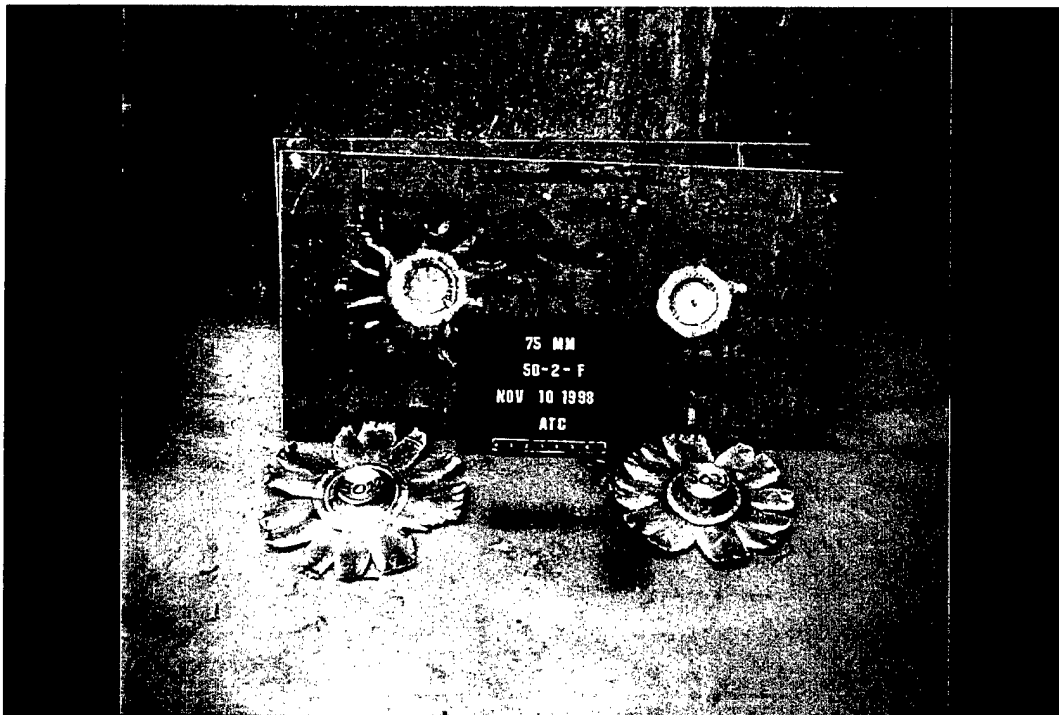

Figure 35. 75-mm Projectile Test Firing 50-2 After Both Shots (Back).

Table 13. V₅₀ Velocity Data

Projectile	Sample No.	Average Thickness	Rounds Considered	V ₅₀ Velocity (ft/s)	ZMR	GAP	Spread
0.50-cal. AP M2	1.4-1	1.430	10	2,027	0	0	100
0.50-cal. AP M2	1.4-2	1.429	10	2,032	1	0	49
0.50-cal. AP M2	1.4-3	1.427	10	2,050	0	19	64
0.50-cal. AP M2	1.4-4	1.432	10	2,071	19	0	52
0.50-cal. AP M2	1.4-5	1.432	10	2,058	6	0	54
0.50-cal. AP M2	1.4-6	1.431	10	2,045	0	8	51
0.50-cal. AP M2	1.4-7	1.427	10	2,058	0	2	46
0.50-cal. AP M2	1.4-8	1.433	10	2,050	20	0	45
0.50-cal. AP M2	1.4-9	1.429	10	2,060	17	0	49
0.50-cal. AP M2	2.6-1	2.650	10	2,892	19	0	35
0.50-cal. AP M2	2.6-2	2.642	10	2,886	64	0	74
0.50-cal. AP M2	2.6-3	2.647	10	2,888	8	0	39
0.50-cal. AP M2	2.6-4	2.646	10	2,891	9	0	28
0.50-cal. AP M2	2.6-5	2.644	10	2,907	19	0	41
0.50-cal. AP M2	2.6-6	2.652	10	2,907	18	0	64
0.50-cal. AP M2	2.6-7	2.646	10	2,901	8	0	43
0.50-cal. AP M2	2.6-8	2.640	10	2,912	27	0	33
0.50-cal. AP M2	2.6-9	2.648	10	2,906	7	0	46
145-mm API BS41	2.9-1	2.952	10	2,753	3	0	121
145-mm API BS41	2.9-2	2.953	10	2,794	12	0	167
145-mm API BS41	2.9-3	2.957	10	2,800	10	0	129
145-mm API BS41	2.9-4	2.955	10	2,812	0	11	120
145-mm API BS41	2.9-5	2.949	10	2,805	12	0	81
145-mm API BS41	2.9-6	2.960	10	2,784	44	0	79
145-mm API BS41	2.9-7	2.948	10	2,787	8	0	58
145-mm API BS41	2.9-8	2.958	10	2,809	0	6	49
145-mm API BS41	2.9-9	2.958	10	2,791	0	5	75
0.50-cal. AP M2	2.9-1	2.952	10	3,095	30	0	323
0.50-cal. AP M2	2.9-2	2.953	10	3,073	25	0	54
0.50-cal. AP M2	2.9-3	2.957	10	3,113	6	0	96
0.50-cal. AP M2	2.9-4	2.955	10	3,094	8	0	45
0.50-cal. AP M2	2.9-5	2.949	10	3,118	0	0	58
0.50-cal. AP M2	2.9-6	2.960	10	3,089	28	0	92
0.50-cal. AP M2	2.9-7	2.948	10	3,110	10	0	122
0.50-cal. AP M2	2.9-8	2.958	10	3,154	13	0	397
0.50-cal. AP M2	2.9-9	2.958	10	3,141	0	3	112
145-mm API BS41	3.1-1	3.173	10	2,919	17	0	157

Table 13. V₅₀ Velocity Data (Continued)

Projectile	Sample No.	Average Thickness	Rounds Considered	V ₅₀ Velocity (ft/s)	ZMR	GAP	Spread
145-mm API BS41	3.1-2	3.186	10	2,949	6	0	161
145-mm API BS41	3.1-3	3.176	10	2,927	7	0	73
145-mm API BS41	3.1-4	3.174	10	2,905	2	0	84
145-mm API BS41	3.1-5	3.166	10	2,931	26	0	46
145-mm API BS41	3.1-6	3.173	10	2,915	17	0	58
145-mm API BS41	3.1-7	3.177	10	2,944	30	0	64
145-mm API BS41	3.1-8	3.183	10	2,924	0	4	54
145-mm API BS41	3.1-9	3.191	10	2,933	14	0	44
145-mm API BS41	4.1-1	3.963	10	3,314	16	0	54
145-mm API BS41	4.1-2	3.988	10	3300	7	0	95
145-mm API BS41	4.1-3	4.033	10	3,317	55	0	81
145-mm API BS41	4.1-4	4.028	10	3,329	8	0	76
145-mm API BS41	4.1-5	4.030	10	3,332	27	0	88
145-mm API BS41	4.1-6	4.025	10	3,357	48	0	57
145-mm API BS41	4.1-7	3.988	10	3,292	40	0	70
145-mm API BS41	4.1-8	4.035	10	3,050	7	0	50

MIL-DTL-46192 [2]. An amendment was prepared by the authors for inclusion into MIL-DTL-46192 [2]. A copy of this amendment was sent to the Standardization Group on 18 January 2000 and is presented in Appendix A.

4. Summary and Conclusion

4.1 Part 1: Mechanical Property and Chemical Resistance Characterization. The mechanical property characterization was completed. The results compared favorably with previously published data for the material. The UTS and the YS for the T87 weldments were only slightly lower than values previously presented by Chase et al. [14] (45.9 and 30.4 vs. 43.8 and 27.4, respectively). Correspondingly, percent elongation was slightly higher, 4.2 vs. 5.0. The fatigue data generated fell within expectations. The T87-T87 weldment data showed a 10–20% decrease in the fatigue strength, as compared with base material when tested by the

Table 14. Minimum Required Ballistic Limits 0.50-cal. AP M2 Projectiles vs. Al2519 Plate at 0° Obliquity

Thickness (in)	Required (BL(P)FPS)	Thickness (in)	Required (BL(P)FPS)	Thickness (in)	Required (BL(P)FPS)	Thickness (in)	Required (BL(P)FPS)
1.400	1,988	1.800	23,12	2.200	2,596	2.600	2,853
1.410	1,997	1.810	23,20	2.210	2,603	2.610	2,859
1.420	2,005	1.820	23,27	2.220	2,610	2.620	2,865
1.430	2,014	1.830	23,35	2.230	2,617	2.630	2,871
1.440	2,023	1.840	23,42	2.240	2,623	2.640	2,877
1.450	2,031	1.850	23,49	2.250	2,630	2.650	2,883
1.460	2,040	1.860	23,57	2.260	2,636	2.660	2,889
1.470	2,048	1.870	23,64	2.270	2,643	2.670	2,895
1.480	2,057	1.880	23,72	2.280	2,650	2.680	2,902
1.490	2,065	1.890	23,79	2.290	2,656	2.690	2,908
1.500	2,074	1.900	23,86	2.300	2,663	2.700	2,914
1.510	2,082	1.910	23,94	2.310	2,669	2.710	2,920
1.520	2,090	1.920	24,01	2.320	2,676	2.720	2,926
1.530	2,099	1.930	24,08	2.330	2,682	2.730	2,931
1.540	2,107	1.940	24,15	2.340	2,689	2.740	2,937
1.550	2,115	1.950	24,23	2.350	2,695	2.750	2,943
1.560	2,123	1.960	24,30	2.360	2,702	2.760	2,949
1.570	2,132	1.970	24,37	2.370	2,708	2.770	2,955
1.580	2,140	1.980	24,44	2.380	2,715	2.780	2,961
1.590	2,148	1.990	24,51	2.390	2,721	2.790	2,967
1.600	2,156	2.000	24,58	2.400	2,728	2.800	2,973
1.610	2,164	2.010	24,65	2.410	2,734	2.810	2,979
1.620	2,172	2.020	24,72	2.420	2,740	2.820	2,985
1.630	2,180	2.030	24,79	2.430	2,747	2.830	2,991
1.640	2,188	2.040	24,87	2.440	2,753	2.840	2,996
1.650	2,196	2.050	24,94	2.450	2,759	2.850	3,002

Table 14. Minimum Required Ballistic Limits 0.50-cal. AP M2 Projectiles vs. A12519 Plate at 0° Obliquity (Continued)

Thickness (in)	Required (BL(P)FPS)	Thickness (in)	Required (BL(P)FPS)	Thickness (in)	Required (BL(P)FPS)	Thickness (in)	Required (BL(P)FPS)
1.660	2,204	2.060	2,501	2.460	2,766	2.860	3,008
1.670	2,212	2.070	2,507	2.470	2,772	2.870	3,014
1.680	2,220	2.080	2,514	2.480	2,778	2.880	3,020
1.690	2,228	2.090	2,521	2.490	2,785	2.890	3,025
1.700	2,235	2.100	2,528	2.500	2,791	2.900	3,031
1.710	2,243	2.110	2,535	2.510	2,797	2.910	3,037
1.720	2,251	2.120	2,542	2.520	2,803	2.920	3,043
1.730	2,259	2.130	2,549	2.530	2,810	2.930	3,048
1.740	2,266	2.140	2,556	2.540	2,816	2.940	3,054
1.750	2,274	2.150	2,563	2.550	2,822	2.950	3,060
1.760	2,282	2.160	2,569	2.560	2,828	2.960	3,066
1.770	2,289	2.170	2,576	2.570	2,834	2.970	3,071
1.780	2,297	2.180	2,583	2.580	2,841	2.980	3,077
1.790	2,304	2.190	2,590	2.590	2,847	2.990	3,083
—	—	—	—	—	—	3.000	3,088

Table 15. Minimum Required Ballistic Limits 14.5-mm BS 41 Projectiles vs. Al2519 Plate at 0° Obliquity

Thickness (in)	Required (BL(P)FPS)	Thickness (in)	Required (BL(P)FPS)	Thickness (in)	Required (BL(P)FPS)	Thickness (in)	Required (BL(P)FPS)
2.900	2,743	3.200	2,903	3.500	3,056	3.800	3,201
2.920	2,754	3.220	2,914	3.520	3,066	3.820	3,211
2.930	2,759	3.230	2,919	3.530	3,071	3.830	3,215
2.940	2,765	3.240	2,924	3.540	3,076	3.840	3,220
2.950	2,770	3.250	2,929	3.550	3,081	3.850	3,225
2.960	2,776	3.260	2,935	3.560	3,085	3.860	3,229
2.970	2,781	3.270	2,940	3.570	3,090	3.870	3,234
2.980	2,786	3.280	2,945	3.580	3,095	3.880	3,239
2.990	2,792	3.290	2,950	3.590	3,100	3.890	3,243
3.000	2,797	3.300	2,955	3.600	3,105	3.900	3,248
3.010	2,803	3.310	2,960	3.610	3,110	3.910	3,253
3.020	2,808	3.320	2,965	3.620	3,115	3.920	3,257
3.030	2,814	3.330	2,970	3.630	3,120	3.930	3,262
3.040	2,819	3.340	2,976	3.640	3,124	3.940	3,267
3.050	2,824	3.350	2,981	3.650	3,129	3.950	3,271
3.060	2,830	3.360	2,986	3.660	3,134	3.960	3,276
3.070	2,835	3.370	2,991	3.670	3,139	3.970	3,281
3.080	2,840	3.380	2,996	3.680	3,144	3.980	3,285
3.090	2,846	3.390	3,001	3.690	3,149	3.990	3,290
3.100	2,851	3.400	3,006	3.700	3,153	4.000	3,294
3.110	2,856	3.410	3,011	3.710	3,158	4.010	3,299
3.120	2,862	3.420	3,016	3.720	3,163	4.020	3,304
3.130	2,867	3.430	3,021	3.730	3,168	4.030	3,308
3.140	2,872	3.440	3,026	3.740	3,173	4.040	3,313
3.150	2,877	3.450	3,031	3.750	3,177	4.050	3,317
3.160	2,883	3.460	3,036	3.760	3,182	4.060	3,322

Table 15. Minimum Required Ballistic Limits 14.5-mm BS 41 Projectiles vs. A12519 Plate at 0° Obliquity (Continued)

Thickness (in)	Required (BL(P)FPS)	Thickness (in)	Required (BL(P)FPS)	Thickness (in)	Required (BL(P)FPS)	Thickness (in)	Required (BL(P)FPS)
3.170	2888	3.470	3041	3.770	3187	4.070	3326
3.180	2893	3.480	3046	3.780	3192	4.080	3331
3.190	2898	3.490	3051	3.790	3196	4.090	3336
—	—	—	—	—	—	4.100	3340

rotating beam. The axial data showed almost a 50% decrease for the same groups. These results cannot be compared with the Chase et al. [14] data due to the variation in weldment design and specimen type. In general, the salt-fog-exposed samples demonstrated a 10% drop in fatigue strength when compared to baseline fatigue properties. These results compared well with the exposure data for this material. The chemical resistance of untreated Al2519 is poor and proved to be so within the scope of this study.

4.2 Part 2: Ballistic Characterization. As a result of this effort, the only ballistic data that can be used for military acceptance is found in Appendix A, Amendment 1 to MIL-DTL-46192 C (MR) [2], Tables A-V and A-VI.

5. References

1. U.S. Department of the Navy, U.S. Army Research Laboratory. "MIL-STD-1946 Welding of Aluminum Alloy Armor." Canceled, December 1995.
2. U.S. Department of the Navy, U.S. Army Research Laboratory. "MIL-DTL-46192 Aluminum Alloy Armor Rolled Plate (1/2 to 4 Inches Thick), Weldable (Alloy 2519)." Formerly MIL-A-46192, July 1991.
3. American Society for Testing and Materials. "ASTM-E-8 Standard Test Methods for Tension Testing of Metallic Materials." West Conshohocken, PA, 1998.
4. American National Standards Institute/American Welding Society (ANSI/AWS). *Methods for Mechanical Testing of Welds*. B-4.0, AWS Structural Welding Committee, Miami, FL, 1998.
5. American Society for Testing and Materials. "ASTM-E-466 Standard Practice for Conducting Force Controlled Constant Amplitude Axial Fatigue Tests of Metallic Materials." West Conshohocken, PA, 1996.
6. American Society for Testing and Materials. "ASTM-G-34 Standard Test Method for Exfoliation Corrosion Susceptibility in 2XXX and 7XXX Series Aluminum Alloys." West Conshohocken, PA, 1996.
7. American Society for Testing and Materials. "ASTM-G-112 Standard Guide for Conducting Exfoliation Corrosion Tests in Aluminum Alloys." West Conshohocken, PA, 1997.
8. American Society for Testing and Materials. "ASTM-B-117 Standard Practice for Operating Salt Spray (Fog) Apparatus." West Conshohocken, PA, 1997.
9. American Society for Testing and Materials. "ASTM-G-38 Standard Practice for Making and Using C-Ring Stress Corrosion Test Specimens." West Conshohocken, PA, 1995.
10. American Society for Testing and Materials. "ASTM-G-47 Standard Test Method for Determining Susceptibility to Stress Corrosion Cracking of 2XXX and 7XXX Aluminum Alloy Products." West Conshohocken, PA, 1998.
11. American Society for Testing and Materials. "ASTM-G-44 Standard Practice for Exposure of Metals and Alloys by Alternate Immersion in Neutral 3.5% Sodium Chloride Solutions." West Conshohocken, PA, 1995.

12. U.S. Department of the Navy, U.S. Army Research Laboratory. "MIL-DTL-46027 Armor Plate, Aluminum Alloy, Weldable 5083 and 5456." September 1998.
13. United Defense Limited Partnership. "GSD-99.055/GAM Hull Material Change." Memorandum from Armament Systems Division, Minneapolis, MN, to Ground Systems Division, Santa Clara, CA, June 1999.
14. Chase, M., N. Kackley, and W. Bethoney. "Engineering and Ballistic Properties of a Newly Developed 2XXX Series Aluminum Alloy Armor." *Ninth International Symposium on Ballistics*, vol. 2, pp. 511-521, American Defense Preparedness Association, Shrivenham, England, 1986.

Appendix A:

Amendment 1 to MIL-DTL-46192 C (MR)

Note: This appendix appears in its original form, without editorial change.

INTENTIONALLY LEFT BLANK.

INCH-POUND

MIL-DTL-46192C(MR)
AMENDMENT 1

SUPERSEDING
MIL-DTL-46192C(MR)
28 August 1998

DETAILED SPECIFICATION

ALUMINUM ALLOY ARMOR ROLLED PLATE (1/2 TO 4 INCHES THICK),
WELDABLE (ALLOY 2519)

This amendment forms a part of MIL-A-46192C(MR), dated 28 August 1998, and is approved for use by all Departments and Agencies of the Department of Defense.

PAGE 9

Table V.: Delete the footnote (a).

APPENDIX A

Add the attached Table A-V. at the end of the specification.

Add the attached Table A-VI. after Table A-V.

Custodian:
Army - MR

Preparing activity:
Army - MR

Review activities:
Army - AT, AR, TE
DLA - IS

Project 9535-XXXX

AMSC N/A

FSC 9535

DISTRIBUTION STATEMENT A: Approved for public release; distribution is unlimited.
MIL-DTL-46192C (MR)

APPENDIX A

TABLE A-V. MINIMUM REQUIRED BALLISTIC LIMITS - CALIBER .50 AP M2 PROJECTILES
VERSUS 2519 ALUMINUM PLATE AT 0° OBLIQUITY

REQUIRED INCHES	THICKNESS, BL(P), FPS	REQUIRED INCHES	THICKNESS, BL(P), FPS	REQUIRED INCHES	THICKNESS, BL(P), FPS	REQUIRED INCHES	THICKNESS, BL(P), FPS
1.400	1988	1.800	2312	2.200	2596	2.600	2853
1.410	1997	1.810	2320	2.210	2603	2.610	2859
1.420	2005	1.820	2327	2.220	2610	2.620	2865
1.430	2014	1.830	2335	2.230	2617	2.630	2871
1.440	2023	1.840	2342	2.240	2623	2.640	2877
1.450	2031	1.850	2349	2.250	2630	2.650	2883
1.460	2040	1.860	2357	2.260	2636	2.660	2889
1.470	2048	1.870	2364	2.270	2643	2.670	2895
1.480	2057	1.880	2372	2.280	2650	2.680	2902
1.490	2065	1.890	2379	2.290	2656	2.690	2908
*1.500	2074	1.900	2386	2.300	2663	2.700	2914
1.510	2082	1.910	2394	2.310	2669	2.710	2920
1.520	2090	1.920	2401	2.320	2676	2.720	2926
1.530	2099	1.930	2408	2.330	2682	2.730	2931
1.540	2107	1.940	2415	2.340	2689	2.740	2937
1.550	2115	1.950	2423	2.350	2695	2.750	2943
1.560	2123	1.960	2430	2.360	2702	2.760	2949
1.570	2132	1.970	2437	2.370	2708	2.770	2955
1.580	2140	1.980	2444	2.380	2715	2.780	2961
1.590	2148	1.990	2451	2.390	2721	2.790	2967
1.600	2156	2.000	2458	2.400	2728	2.800	2973
1.610	2164	2.010	2465	2.410	2734	2.810	2979
1.620	2172	2.020	2472	2.420	2740	2.820	2985
1.630	2180	2.030	2479	2.430	2747	2.830	2991
1.640	2188	2.040	2487	2.440	2753	2.840	2996
1.650	2196	2.050	2494	2.450	2759	2.850	3002
1.660	2204	2.060	2501	2.460	2766	2.860	3008
1.670	2212	2.070	2507	2.470	2772	2.870	3014
1.680	2220	2.080	2514	2.480	2778	2.880	3020
1.690	2228	2.090	2521	2.490	2785	2.890	3025
1.700	2235	2.100	2528	2.500	2791	2.900	3031
1.710	2243	2.110	2535	2.510	2797	2.910	3037
1.720	2251	2.120	2542	2.520	2803	2.920	3043
1.730	2259	2.130	2549	2.530	2810	2.930	3048
1.740	2266	2.140	2556	2.540	2816	2.940	3054
1.750	2274	2.150	2563	2.550	2822	2.950	3060
1.760	2282	2.160	2569	2.560	2828	2.960	3066
1.770	2289	2.170	2576	2.570	2834	2.970	3071
1.780	2297	2.180	2583	2.580	2841	2.980	3077
1.790	2304	2.190	2590	2.590	2847	2.990	3083
						**3.000	3088

* Specification requirements begin for ordered thickness 1.500 inch.
** Specification requirements end for ordered thickness 3.000 inch.

MIL-DTL-46192C (MR)

APPENDIX A (Cont.)

TABLE VI. MINIMUM REQUIRED BALLISTIC LIMITS - 14.5MM BS41 PROJECTILES
VERSUS 2519 ALUMINUM PLATE AT 0° OBLIQUITY

<u>THICKNESS, REQUIRED</u> <u>INCHES</u>	<u>BL (P), FPS</u>	<u>THICKNESS, REQUIRED</u> <u>INCHES</u>	<u>BL (P), FPS</u>	<u>THICKNESS, REQUIRED</u> <u>INCHES</u>	<u>BL (P), FPS</u>	<u>THICKNESS, REQUIRED</u> <u>INCHES</u>	<u>BL (P), FPS</u>
2.900	2743	3.200	2903	3.500	3056	3.800	3201
2.910	2748	3.210	2909	3.510	3061	3.810	3206
2.920	2754	3.220	2914	3.520	3066	3.820	3211
2.930	2759	3.230	2919	3.530	3071	3.830	3215
2.940	2765	3.240	2924	3.540	3076	3.840	3220
2.950	2770	3.250	2929	3.550	3081	3.850	3225
2.960	2776	3.260	2935	3.560	3085	3.860	3229
2.970	2781	3.270	2940	3.570	3090	3.870	3234
2.980	2786	3.280	2945	3.580	3095	3.880	3239
2.990	2792	3.290	2950	3.590	3100	3.890	3243
*3.000	2797	3.300	2955	3.600	3105	3.900	3248
3.010	2803	3.310	2960	3.610	3110	3.910	3253
3.020	2808	3.320	2965	3.620	3115	3.920	3257
3.030	2814	3.330	2970	3.630	3120	3.930	3262
3.040	2819	3.340	2976	3.640	3124	3.940	3267
3.050	2824	3.350	2981	3.650	3129	3.950	3271
3.060	2830	3.360	2986	3.660	3134	3.960	3276
3.070	2835	3.370	2991	3.670	3139	3.970	3281
3.080	2840	3.380	2996	3.680	3144	3.980	3285
3.090	2846	3.390	3001	3.690	3149	3.990	3290
3.100	2851	3.400	3006	3.700	3153	**4.000	3294
3.110	2856	3.410	3011	3.710	3158	4.010	3299
3.120	2862	3.420	3016	3.720	3163	4.020	3304
3.130	2867	3.430	3021	3.730	3168	4.030	3308
3.140	2872	3.440	3026	3.740	3173	4.040	3313
3.150	2877	3.450	3031	3.750	3177	4.050	3317
3.160	2883	3.460	3036	3.760	3182	4.060	3322
3.170	2888	3.470	3041	3.770	3187	4.070	3326
3.180	2893	3.480	3046	3.780	3192	4.080	3331
3.190	2898	3.490	3051	3.790	3196	4.090	3336

* Specification requirements begin for ordered thickness 3.000 inch.

** Specification requirements end for ordered thickness 4.000 inch.

INTENTIONALLY LEFT BLANK.

Appendix B:

**Individual Test Shots for Developing the
 V_{50} Acceptance Tables**

INTENTIONALLY LEFT BLANK.

Table B-1. Individual Test Shots for Developing the V₅₀ Acceptance Tables

Sample No.	Projectile	Round	Striking Velocity	Penetration
1.4-1	0.50-cal. AP M2	199904356	1,757	P
1.4-1	0.50-cal. AP M2	199904357	1,883	P
1.4-1	0.50-cal. AP M2	199904358	1,904	P
1.4-1	0.50-cal. AP M2	199904370	1,962	P
1.4-1	0.50-cal. AP M2	199904359	1,971	P
1.4-1	0.50-cal. AP M2	199904368	1,984	P
1.4-1	0.50-cal. AP M2	199904355	1,994	D ^a
1.4-1	0.50-cal. AP M2	199904367	1,998	P
1.4-1	0.50-cal. AP M2	199904361	2,001	P
1.4-1	0.50-cal. AP M2	199904362	2,041	P
1.4-1	0.50-cal. AP M2	199904369	2,041	C
1.4-1	0.50-cal. AP M2	199904363	2,047	C
1.4-1	0.50-cal. AP M2	199904360	2,057	C
1.4-1	0.50-cal. AP M2	199904366	2,059	C
1.4-1	0.50-cal. AP M2	199904364	2,071	C
1.4-1	0.50-cal. AP M2	199904365	2,082	C
1.4-1	0.50-cal. AP M2	199904354	2,096	C
1.4-2	0.50-cal. AP M2	199904371	1,997	P
1.4-2	0.50-cal. AP M2	199906008	2,001	P
1.4-2	0.50-cal. AP M2	199906011	2,011	P
1.4-2	0.50-cal. AP M2	199906010	2,015	P
1.4-2	0.50-cal. AP M2	199904373	2,020	P
1.4-2	0.50-cal. AP M2	199904374	2,024	P
1.4-2	0.50-cal. AP M2	199904381	2,024	P
1.4-2	0.50-cal. AP M2	199906003	2,029	C
1.4-2	0.50-cal. AP M2	199904380	2,030	P
1.4-2	0.50-cal. AP M2	199906006	2,036	C
1.4-2	0.50-cal. AP M2	199906009	2,037	C
1.4-2	0.50-cal. AP M2	199906007	2,039	C
1.4-2	0.50-cal. AP M2	199906012	2,048	D
1.4-2	0.50-cal. AP M2	199904379	2,064	C
1.4-2	0.50-cal. AP M2	199904378	2,067	C
1.4-2	0.50-cal. AP M2	199904372	2,068	C
1.4-2	0.50-cal. AP M2	199906001	2,071	C
1.4-2	0.50-cal. AP M2	199906002	2,076	C
1.4-2	0.50-cal. AP M2	199906005	2,081	C
1.4-2	0.50-cal. AP M2	199904375	2,082	C

^a D is disallowed.

Table B-1. Individual Test Shots for Developing the V₅₀ Acceptance Tables (Continued)

Sample No.	Projectile	Round	Striking Velocity	Penetration
1.4-2	0.50-cal. AP M2	199904376	2,082	C
1.4-2	0.50-cal. AP M2	199904377	2,082	C
1.4-2	0.50-cal. AP M2	199906004	2,086	C
1.4-3	0.50-cal. AP M2	199904383	2,014	P
1.4-3	0.50-cal. AP M2	199904384	2,020	P
1.4-3	0.50-cal. AP M2	199904390	2,039	P
1.4-3	0.50-cal. AP M2	199904385	2,041	P
1.4-3	0.50-cal. AP M2	199904391	2,042	P
1.4-3	0.50-cal. AP M2	199904382	2,061	C
1.4-3	0.50-cal. AP M2	199904389	2,063	C
1.4-3	0.50-cal. AP M2	199904388	2,064	C
1.4-3	0.50-cal. AP M2	199904386	2,077	C
1.4-3	0.50-cal. AP M2	199904387	2,078	C
1.4-4	0.50-cal. AP M2	199904394	2,050	P
1.4-4	0.50-cal. AP M2	199904396	2,056	C
1.4-4	0.50-cal. AP M2	199904399	2,057	P
1.4-4	0.50-cal. AP M2	199904395	2,061	P
1.4-4	0.50-cal. AP M2	199904393	2,067	P
1.4-4	0.50-cal. AP M2	199904392	2,073	C
1.4-4	0.50-cal. AP M2	199904400	2,075	P
1.4-4	0.50-cal. AP M2	199904397	2,076	C
1.4-4	0.50-cal. AP M2	199904398	2,097	C
1.4-4	0.50-cal. AP M2	199904401	2,102	C
1.4-5	0.50-cal. AP M2	199904411	2,022	P
1.4-5	0.50-cal. AP M2	199904405	2,046	P
1.4-5	0.50-cal. AP M2	199904404	2,050	P
1.4-5	0.50-cal. AP M2	199904409	2,054	C
1.4-5	0.50-cal. AP M2	199904410	2,059	P
1.4-5	0.50-cal. AP M2	199904408	2,060	P
1.4-5	0.50-cal. AP M2	199904406	2,069	C
1.4-5	0.50-cal. AP M2	199904402	2,070	C
1.4-5	0.50-cal. AP M2	199904407	2,075	C
1.4-5	0.50-cal. AP M2	199904403	2,076	C
1.4-6	0.50-cal. AP M2	199904419	2,020	P
1.4-6	0.50-cal. AP M2	199904420	2,023	P
1.4-6	0.50-cal. AP M2	199904418	2030	P
1.4-6	0.50-cal. AP M2	199904421	2,033	P
1.4-6	0.50-cal. AP M2	199904416	2,038	P

^a D is disallowed.

Table B-1. Individual Test Shots for Developing the V_{50} Acceptance Tables (Continued)

Sample No.	Projectile	Round	Striking Velocity	Penetration
1.4-6	0.50-cal. AP M2	199904415	2,039	P
1.4-6	0.50-cal. AP M2	199904414	2,047	C
1.4-6	0.50-cal. AP M2	199904417	2,049	C
1.4-6	0.50-cal. AP M2	199904413	2,055	C
1.4-6	0.50-cal. AP M2	199904412	2,063	C
1.4-6	0.50-cal. AP M2	199904422	2,074	C
1.4-7	0.50-cal. AP M2	199904440	2,034	P
1.4-7	0.50-cal. AP M2	199904439	2,040	P
1.4-7	0.50-cal. AP M2	199904438	2,041	P
1.4-7	0.50-cal. AP M2	199904434	2,057	P
1.4-7	0.50-cal. AP M2	199904441	2,057	P
1.4-7	0.50-cal. AP M2	199904436	2,059	C
1.4-7	0.50-cal. AP M2	199904437	2,066	D
1.4-7	0.50-cal. AP M2	199904433	2,071	C
1.4-7	0.50-cal. AP M2	199904442	2,072	C
1.4-7	0.50-cal. AP M2	199904435	2,074	C
1.4-7	0.50-cal. AP M2	199904443	2,080	C
1.4-8	0.50-cal. AP M2	199904453	2,030	P
1.4-8	0.50-cal. AP M2	199904448	2,031	P
1.4-8	0.50-cal. AP M2	199904455	2,032	P
1.4-8	0.50-cal. AP M2	199904452	2,034	P
1.4-8	0.50-cal. AP M2	199904454	2,046	C
1.4-8	0.50-cal. AP M2	199904450	2,054	C
1.4-8	0.50-cal. AP M2	199904446	2,063	C
1.4-8	0.50-cal. AP M2	199904447	2,066	P
1.4-8	0.50-cal. AP M2	199904444	2,071	C
1.4-8	0.50-cal. AP M2	199904451	2,075	C
1.4-8	0.50-cal. AP M2	199904449	2,087	C
1.4-8	0.50-cal. AP M2	199904445	2,088	C
1.4-9	0.50-cal. AP M2	199904465	2,037	P
1.4-9	0.50-cal. AP M2	199904456	2,039	P
1.4-9	0.50-cal. AP M2	199904463	2,043	C
1.4-9	0.50-cal. AP M2	199904464	2,051	P
1.4-9	0.50-cal. AP M2	199904462	2,058	P
1.4-9	0.50-cal. AP M2	199904457	2,060	P
1.4-9	0.50-cal. AP M2	199904461	2,068	C
1.4-9	0.50-cal. AP M2	199904460	2,077	C

^a D is disallowed.

Table B-1. Individual Test Shots for Developing the V₅₀ Acceptance Tables (Continued)

Sample No.	Projectile	Round	Striking Velocity	Penetration
1.4-9	0.50-cal. AP M2	199904458	2,084	C
1.4-9	0.50-cal. AP M2	199904459	2,086	C
2.6-1	0.50-cal. AP M2	199904467	2,034	P
2.6-1	0.50-cal. AP M2	199904466	2,038	P
2.6-1	0.50-cal. AP M2	199904468	2,094	P
2.6-1	0.50-cal. AP M2	199904469	2,124	P
2.6-1	0.50-cal. AP M2	199904470	2,196	P
2.6-1	0.50-cal. AP M2	199904471	2,294	P
2.6-1	0.50-cal. AP M2	199904472	2,501	P
2.6-1	0.50-cal. AP M2	199904473	2,701	P
2.6-1	0.50-cal. AP M2	199904479	2,873	P
2.6-1	0.50-cal. AP M2	199904474	2,879	C
2.6-1	0.50-cal. AP M2	199904475	2,882	P
2.6-1	0.50-cal. AP M2	199904484	2,884	P
2.6-1	0.50-cal. AP M2	199904485	2,884	P
2.6-1	0.50-cal. AP M2	199904481	2,887	D
2.6-1	0.50-cal. AP M2	199904483	2,898	P
2.6-1	0.50-cal. AP M2	199904476	2,902	C
2.6-1	0.50-cal. AP M2	199904482	2,903	C
2.6-1	0.50-cal. AP M2	199904478	2,904	C
2.6-1	0.50-cal. AP M2	199904480	2,908	C
2.6-1	0.50-cal. AP M2	199904477	2,932	C
2.6-2	0.50-cal. AP M2	199904492	2,837	P
2.6-2	0.50-cal. AP M2	199904502	2,845	P
2.6-2	0.50-cal. AP M2	199904499	2,855	C
2.6-2	0.50-cal. AP M2	199904495	2,875	P
2.6-2	0.50-cal. AP M2	199904491	2,882	P
2.6-2	0.50-cal. AP M2	199904500	2,886	C
2.6-2	0.50-cal. AP M2	199904501	2,890	C
2.6-2	0.50-cal. AP M2	199904487	2,894	C
2.6-2	0.50-cal. AP M2	199904493	2,896	C
2.6-2	0.50-cal. AP M2	199904490	2,897	D
2.6-2	0.50-cal. AP M2	199904498	2,900	C
2.6-2	0.50-cal. AP M2	199904497	2,902	C
2.6-2	0.50-cal. AP M2	199904496	2,904	C
2.6-2	0.50-cal. AP M2	199904494	2,907	C
2.6-2	0.50-cal. AP M2	199904489	2,917	P

^a D is disallowed.

Table B-1. Individual Test Shots for Developing the V_{50} Acceptance Tables (Continued)

Sample No.	Projectile	Round	Striking Velocity	Penetration
2.6-2	0.50-cal. AP M2	199904486	2,919	P
2.6-2	0.50-cal. AP M2	199904488	2,925	C
2.6-3	0.50-cal. AP M2	199904534	2,864	P
2.6-3	0.50-cal. AP M2	199904533	2,872	P
2.6-3	0.50-cal. AP M2	199904539	2,876	P
2.6-3	0.50-cal. AP M2	199904541	2,882	P
2.6-3	0.50-cal. AP M2	199904536	2,890	C
2.6-3	0.50-cal. AP M2	199904540	2,893	C
2.6-3	0.50-cal. AP M2	199904537	2,896	C
2.6-3	0.50-cal. AP M2	199904538	2,898	P
2.6-3	0.50-cal. AP M2	199904535	2,903	C
2.6-3	0.50-cal. AP M2	199904542	2,903	C
2.6-4	0.50-cal. AP M2	199904543	2,879	P
2.6-4	0.50-cal. AP M2	199904544	2,879	P
2.6-4	0.50-cal. AP M2	199904549	2,882	P
2.6-4	0.50-cal. AP M2	199904552	2,883	P
2.6-4	0.50-cal. AP M2	199904548	2,886	C
2.6-4	0.50-cal. AP M2	199904546	2,888	P
2.6-4	0.50-cal. AP M2	199904551	2,892	C
2.6-4	0.50-cal. AP M2	199904545	2,895	P
2.6-4	0.50-cal. AP M2	199904550	2,898	C
2.6-4	0.50-cal. AP M2	199904547	2,899	C
2.6-4	0.50-cal. AP M2	199904553	2,907	C
2.6-5	0.50-cal. AP M2	199904558	2,892	C
2.6-5	0.50-cal. AP M2	199904561	2,894	P
2.6-5	0.50-cal. AP M2	199904564	2,895	C
2.6-5	0.50-cal. AP M2	199904560	2,898	P
2.6-5	0.50-cal. AP M2	199904556	2,903	P
2.6-5	0.50-cal. AP M2	199904562	2,904	P
2.6-5	0.50-cal. AP M2	199904555	2,908	P
2.6-5	0.50-cal. AP M2	199904557	2,911	P
2.6-5	0.50-cal. AP M2	199904559	2,913	C
2.6-5	0.50-cal. AP M2	199904554	2,914	C
2.6-5	0.50-cal. AP M2	199904563	2,933	C
2.6-6	0.50-cal. AP M2	199904574	2,865	D
2.6-6	0.50-cal. AP M2	199904575	2,871	P
2.6-6	0.50-cal. AP M2	199904572	2,884	P

^a D is disallowed.

Table B-1. Individual Test Shots for Developing the V_{50} Acceptance Tables (Continued)

Sample No.	Projectile	Round	Striking Velocity	Penetration
2.6-6	0.50-cal. AP M2	199904570	2,901	P
2.6-6	0.50-cal. AP M2	199904569	2,903	P
2.6-6	0.50-cal. AP M2	199904565	2,904	C
2.6-6	0.50-cal. AP M2	199904571	2,905	C
2.6-6	0.50-cal. AP M2	199904573	2,922	P
2.6-6	0.50-cal. AP M2	199904567	2,924	C
2.6-6	0.50-cal. AP M2	199904568	2,925	C
2.6-6	0.50-cal. AP M2	199904566	2,935	C
2.6-7	0.50-cal. AP M2	199904576	2,879	P
2.6-7	0.50-cal. AP M2	199904582	2,880	P
2.6-7	0.50-cal. AP M2	199904577	2,892	P
2.6-7	0.50-cal. AP M2	199904578	2,897	P
2.6-7	0.50-cal. AP M2	199904579	2,899	C
2.6-7	0.50-cal. AP M2	199904584	2,903	C
2.6-7	0.50-cal. AP M2	199904586	2,907	P
2.6-7	0.50-cal. AP M2	199904581	2,912	C
2.6-7	0.50-cal. AP M2	199904583	2,918	C
2.6-7	0.50-cal. AP M2	199904580	2,922	C
2.6-7	0.50-cal. AP M2	199904585	2,923	C
2.6-8	0.50-cal. AP M2	199904600	2,879	P
2.6-8	0.50-cal. AP M2	199904603	2,883	P
2.6-8	0.50-cal. AP M2	199904601	2,891	P
2.6-8	0.50-cal. AP M2	199904599	2,893	P
2.6-8	0.50-cal. AP M2	199904598	2,899	C
2.6-8	0.50-cal. AP M2	199904602	2,907	C
2.6-8	0.50-cal. AP M2	199904587	2,910	P
2.6-8	0.50-cal. AP M2	199904597	2,911	C
2.6-8	0.50-cal. AP M2	199904591	2,913	C
2.6-8	0.50-cal. AP M2	199904590	2,917	P
2.6-8	0.50-cal. AP M2	199904594	2,919	P
2.6-8	0.50-cal. AP M2	199904592	2,920	C
2.6-8	0.50-cal. AP M2	199904595	2,920	C
2.6-8	0.50-cal. AP M2	199904593	2,926	P
2.6-8	0.50-cal. AP M2	199904596	2,937	C
2.6-8	0.50-cal. AP M2	199904589	2,943	C
2.6-8	0.50-cal. AP M2	199904588	2,955	C
2.6-9	0.50-cal. AP M2	199904604	2,876	P

^a D is disallowed.

Table B-1. Individual Test Shots for Developing the V₅₀ Acceptance Tables (Continued)

Sample No.	Projectile	Round	Striking Velocity	Penetration
2.6-9	0.50-cal. AP M2	199904605	2,884	P
2.6-9	0.50-cal. AP M2	199904611	2,894	P
2.6-9	0.50-cal. AP M2	199904614	2,897	C
2.6-9	0.50-cal. AP M2	199904609	2,898	P
2.6-9	0.50-cal. AP M2	199904612	2,898	P
2.6-9	0.50-cal. AP M2	199904615	2,899	C
2.6-9	0.50-cal. AP M2	199904608	2,902	P
2.6-9	0.50-cal. AP M2	199904607	2,904	P
2.6-9	0.50-cal. AP M2	199904610	2,909	C
2.6-9	0.50-cal. AP M2	199904606	2,920	C
2.6-9	0.50-cal. AP M2	199904613	2,940	C
2.9-1	145-mm API BS41	199906027	2,522	P
2.9-1	145-mm API BS41	199904859	2,576	P
2.9-1	145-mm API BS41	199904858	2,586	P
2.9-1	145-mm API BS41	199904862	2,587	P
2.9-1	145-mm API BS41	199904865	2,667	P
2.9-1	145-mm API BS41	199904866	2,682	P
2.9-1	145-mm API BS41	199906028	2,683	P
2.9-1	145-mm API BS41	199906029	2,686	P
2.9-1	145-mm API BS41	199904860	2,689	P
2.9-1	145-mm API BS41	199904851	2,707	P
2.9-1	145-mm API BS41	199906036	2,718	P
2.9-1	145-mm API BS41	199906037	2,746	P
2.9-1	145-mm API BS41	199906032	2,749	C
2.9-1	145-mm API BS41	199906030	2,752	P
2.9-1	145-mm API BS41	199906035	2,774	C
2.9-1	145-mm API BS41	199906038	2,789	C
2.9-1	145-mm API BS41	199906034	2,797	C
2.9-1	145-mm API BS41	199906031	2,810	C
2.9-1	145-mm API BS41	199906033	2,811	C
2.9-1	145-mm API BS41	199906026	2,818	C
2.9-1	145-mm API BS41	199904861	2,821	C
2.9-1	145-mm API BS41	199904857	2,828	C
2.9-1	145-mm API BS41	199904863	2,910	C
2.9-1	145-mm API BS41	199904856	2,930	C
2.9-1	145-mm API BS41	199904867	3,009	C
2.9-1	145-mm API BS41	199906025	3,009	C

^a D is disallowed.

Table B-1. Individual Test Shots for Developing the V₅₀ Acceptance Tables (Continued)

Sample No.	Projectile	Round	Striking Velocity	Penetration
2.9-1	145-mm API BS41	199904868	3,045	C
2.9-1	145-mm API BS41	199904854	3,047	C
2.9-1	145-mm API BS41	199904864	3,103	C
2.9-1	145-mm API BS41	199904852	3,119	C
2.9-1	145-mm API BS41	199904855	3,130	C
2.9-1	145-mm API BS41	199904853	3,209	C
2.9-1	0.50-cal. AP M2	199904840	2,890	P
2.9-1	0.50-cal. AP M2	199904839	2,906	P
2.9-1	0.50-cal. AP M2	199904841	2,947	P
2.9-1	0.50-cal. AP M2	199904842	2,995	P
2.9-1	0.50-cal. AP M2	199904843	3,063	P
2.9-1	0.50-cal. AP M2	199904850	3,132	C
2.9-1	0.50-cal. AP M2	199904844	3,162	P
2.9-1	0.50-cal. AP M2	199904849	3,163	C
2.9-1	0.50-cal. AP M2	199904848	3,165	C
2.9-1	0.50-cal. AP M2	199904847	3,184	C
2.9-1	0.50-cal. AP M2	199904846	3,229	C
2.9-1	0.50-cal. AP M2	199904845	3,240	C
2.9-2	145-mm API BS41	199904870	2,614	P
2.9-2	145-mm API BS41	199904878	2,645	P
2.9-2	145-mm API BS41	199904869	2,659	P
2.9-2	145-mm API BS41	199904874	2,678	P
2.9-2	145-mm API BS41	199906020	2,714	P
2.9-2	145-mm API BS41	199906021	2,720	P
2.9-2	145-mm API BS41	199904872	2,734	D
2.9-2	145-mm API BS41	199906022	2,755	P
2.9-2	145-mm API BS41	199906024	2,758	P
2.9-2	145-mm API BS41	199906023	2,775	C
2.9-2	145-mm API BS41	199904873	2,787	P
2.9-2	145-mm API BS41	199906019	2,819	C
2.9-2	145-mm API BS41	199904875	2,855	C
2.9-2	145-mm API BS41	199906018	2,873	C
2.9-2	145-mm API BS41	199904880	2,881	C
2.9-2	145-mm API BS41	199904882	2,910	C
2.9-2	145-mm API BS41	199904876	2,920	C
2.9-2	145-mm API BS41	199904871	2,968	C
2.9-2	145-mm API BS41	199906017	2,980	C

^a D is disallowed.

Table B-1. Individual Test Shots for Developing the V₅₀ Acceptance Tables (Continued)

Sample No.	Projectile	Round	Striking Velocity	Penetration
2.9-2	145-mm API BS41	199904879	3,043	C
2.9-2	145-mm API BS41	199906016	3,110	C
2.9-2	145-mm API BS41	199904881	3,117	C
2.9-2	145-mm API BS41	199904877	3,163	C
2.9-2	0.50-cal. AP M2	199904890	3,050	P
2.9-2	0.50-cal. AP M2	199906015	3,052	C
2.9-2	0.50-cal. AP M2	199904891	3,055	P
2.9-2	0.50-cal. AP M2	199904892	3,055	P
2.9-2	0.50-cal. AP M2	199904888	3,057	P
2.9-2	0.50-cal. AP M2	199904886	3,077	P
2.9-2	0.50-cal. AP M2	199904887	3,089	C
2.9-2	0.50-cal. AP M2	199904889	3,090	C
2.9-2	0.50-cal. AP M2	199904885	3,099	C
2.9-2	0.50-cal. AP M2	199906014	3,104	C
2.9-2	0.50-cal. AP M2	199904884	3,128	C
2.9-2	0.50-cal. AP M2	199906013	3,128	C
2.9-2	0.50-cal. AP M2	199904883	3,138	C
2.9-3	145-mm API BS41	199904915	988	D
2.9-3	145-mm API BS41	199904912	2,630	P
2.9-3	145-mm API BS41	199904914	2,665	P
2.9-3	145-mm API BS41	199904909	2,701	P
2.9-3	145-mm API BS41	199904921	2,743	P
2.9-3	145-mm API BS41	199904922	2,744	P
2.9-3	145-mm API BS41	199906040	2,747	P
2.9-3	145-mm API BS41	199904924	2,755	P
2.9-3	145-mm API BS41	199906041	2,755	P
2.9-3	145-mm API BS41	199904925	2,756	P
2.9-3	145-mm API BS41	199904923	2,758	P
2.9-3	145-mm API BS41	199906039	2,763	P
2.9-3	145-mm API BS41	199906042	2,773	P
2.9-3	145-mm API BS41	199906044	2,783	C
2.9-3	145-mm API BS41	199906045	2,793	P
2.9-3	145-mm API BS41	199906043	2,799	C
2.9-3	145-mm API BS41	199904911	2,842	C
2.9-3	145-mm API BS41	199904908	2,852	C
2.9-3	145-mm API BS41	199904920	2,885	C
2.9-3	145-mm API BS41	199904910	2,925	C

^a D is disallowed.

Table B-1. Individual Test Shots for Developing the V₅₀ Acceptance Tables (Continued)

Sample No.	Projectile	Round	Striking Velocity	Penetration
2.9-3	145-mm API BS41	199904907	2,931	C
2.9-3	145-mm API BS41	199904919	2,931	C
2.9-3	145-mm API BS41	199904918	2,998	C
2.9-3	145-mm API BS41	199904906	3,034	C
2.9-3	145-mm API BS41	199904913	3,051	C
2.9-3	145-mm API BS41	199904903	3,061	C
2.9-3	145-mm API BS41	199904917	3,070	C
2.9-3	145-mm API BS41	199904916	3,110	D
2.9-3	145-mm API BS41	199904905	3,179	C
2.9-3	145-mm API BS41	199904904	3,210	C
2.9-3	0.50-cal. AP M2	199904894	3,065	P
2.9-3	0.50-cal. AP M2	199904893	3,078	P
2.9-3	0.50-cal. AP M2	199904895	3,090	P
2.9-3	0.50-cal. AP M2	199904897	3,104	P
2.9-3	0.50-cal. AP M2	199904896	3,114	C
2.9-3	0.50-cal. AP M2	199904898	3,120	P
2.9-3	0.50-cal. AP M2	199904899	3,127	C
2.9-3	0.50-cal. AP M2	199904900	3,134	C
2.9-3	0.50-cal. AP M2	199904901	3,139	C
2.9-3	0.50-cal. AP M2	199904902	3,161	C
2.9-4	145-mm API BS41	199904926	2,759	P
2.9-4	145-mm API BS41	199904935	2,765	P
2.9-4	145-mm API BS41	199904934	2,779	P
2.9-4	145-mm API BS41	199904929	2,790	P
2.9-4	145-mm API BS41	199904927	2,810	P
2.9-4	145-mm API BS41	199904930	2,821	C
2.9-4	145-mm API BS41	199904931	2,832	C
2.9-4	145-mm API BS41	199904933	2,833	C
2.9-4	145-mm API BS41	199904932	2,853	C
2.9-4	145-mm API BS41	199904928	2,879	C
2.9-4	0.50-cal. AP M2	199904944	3,075	P
2.9-4	0.50-cal. AP M2	199904943	3,078	P
2.9-4	0.50-cal. AP M2	199904942	3,079	C
2.9-4	0.50-cal. AP M2	199904940	3,082	P
2.9-4	0.50-cal. AP M2	199904941	3,084	P
2.9-4	0.50-cal. AP M2	199904937	3,087	P
2.9-4	0.50-cal. AP M2	199904938	3,105	C
2.9-4	0.50-cal. AP M2	199904945	3,108	C

^a D is disallowed.

Table B-1. Individual Test Shots for Developing the V₅₀ Acceptance Tables (Continued)

Sample No.	Projectile	Round	Striking Velocity	Penetration
2.9-4	0.50-cal. AP M2	199904939	3,117	C
2.9-4	0.50-cal. AP M2	199904936	3,120	C
2.9-5	145-mm API BS41	199904956	2,763	P
2.9-5	145-mm API BS41	199904963	2,763	P
2.9-5	145-mm API BS41	199904965	2,769	P
2.9-5	145-mm API BS41	199904964	2,779	P
2.9-5	145-mm API BS41	199906046	2,802	C
2.9-5	145-mm API BS41	199904957	2,814	P
2.9-5	145-mm API BS41	199904959	2,839	C
2.9-5	145-mm API BS41	199904962	2,840	C
2.9-5	145-mm API BS41	199904958	2,841	C
2.9-5	145-mm API BS41	199904960	2,844	C
2.9-5	145-mm API BS41	199904961	2,852	C
2.9-5	0.50-cal. AP M2	199904946	3,084	P
2.9-5	0.50-cal. AP M2	199904948	3,102	P
2.9-5	0.50-cal. AP M2	199904947	3,104	P
2.9-5	0.50-cal. AP M2	199904951	3,105	P
2.9-5	0.50-cal. AP M2	199904949	3,119	C
2.9-5	0.50-cal. AP M2	199904950	3,119	P
2.9-5	0.50-cal. AP M2	199904952	3,127	C
2.9-5	0.50-cal. AP M2	199904955	3,134	C
2.9-5	0.50-cal. AP M2	199904954	3,141	C
2.9-5	0.50-cal. AP M2	199904953	3,142	C
2.9-6	145-mm API BS41	199905011	2,745	P
2.9-6	145-mm API BS41	199905009	2,747	C
2.9-6	145-mm API BS41	199905010	2,749	P
2.9-6	145-mm API BS41	199905012	2,761	P
2.9-6	145-mm API BS41	199905008	2,762	P
2.9-6	145-mm API BS41	199905013	2,763	P
2.9-6	145-mm API BS41	199905014	2,774	P
2.9-6	145-mm API BS41	199905007	2,780	C
2.9-6	145-mm API BS41	199905015	2,788	P
2.9-6	145-mm API BS41	199905018	2,791	P
2.9-6	145-mm API BS41	199905017	2,800	C
2.9-6	145-mm API BS41	199905016	2,813	C
2.9-6	145-mm API BS41	199905019	2,826	C
2.9-6	0.50-cal. AP M2	199905002	3,035	P

^a D is disallowed.

Table B-1. Individual Test Shots for Developing the V₅₀ Acceptance Tables (Continued)

Sample No.	Projectile	Round	Striking Velocity	Penetration
2.9-6	0.50-cal. AP M2	199904998	3,047	P
2.9-6	0.50-cal. AP M2	199905003	3,052	P
2.9-6	0.50-cal. AP M2	199905000	3,070	P
2.9-6	0.50-cal. AP M2	199904995	3,071	P
2.9-6	0.50-cal. AP M2	199904999	3,074	P
2.9-6	0.50-cal. AP M2	199905001	3,077	C
2.9-6	0.50-cal. AP M2	199904997	3,093	C
2.9-6	0.50-cal. AP M2	199905004	3,101	C
2.9-6	0.50-cal. AP M2	199904996	3,104	C
2.9-6	0.50-cal. AP M2	199905005	3,105	P
2.9-6	0.50-cal. AP M2	199905006	3,144	C
2.9-7	145-mm API BS41	199905030	1,749	P
2.9-7	145-mm API BS41	199905028	1,753	P
2.9-7	145-mm API BS41	199905029	1,753	P
2.9-7	145-mm API BS41	199905023	1,763	P
2.9-7	145-mm API BS41	199905025	1,767	C
2.9-7	145-mm API BS41	199905026	1,770	C
2.9-7	145-mm API BS41	199905027	1,772	C
2.9-7	145-mm API BS41	199905024	1,773	P
2.9-7	145-mm API BS41	199905022	1,780	C
2.9-7	145-mm API BS41	199905021	1,786	C
2.9-7	0.50-cal. AP M2	199905037	3,057	P
2.9-7	0.50-cal. AP M2	199905041	3,072	P
2.9-7	0.50-cal. AP M2	199905040	3,093	P
2.9-7	0.50-cal. AP M2	199905034	3,098	P
2.9-7	0.50-cal. AP M2	199905039	3,104	C
2.9-7	0.50-cal. AP M2	199905038	3,114	P
2.9-7	0.50-cal. AP M2	199905044	3,117	C
2.9-7	0.50-cal. AP M2	199905033	3,134	C
2.9-7	0.50-cal. AP M2	199905036	3,134	C
2.9-7	0.50-cal. AP M2	199905043	3,179	C
2.9-8	145-mm API BS41	199904969	2,786	P
2.9-8	145-mm API BS41	199904972	2,791	P
2.9-8	145-mm API BS41	199904971	2,793	P
2.9-8	145-mm API BS41	199904973	2,802	P
2.9-8	145-mm API BS41	199904968	2,809	P
2.9-8	145-mm API BS41	199904974	2,815	C

^a D is disallowed.

Table B-1. Individual Test Shots for Developing the V_{50} Acceptance Tables (Continued)

Sample No.	Projectile	Round	Striking Velocity	Penetration
2.9-8	145-mm API BS41	199904970	2,816	C
2.9-8	145-mm API BS41	199904975	2,816	C
2.9-8	145-mm API BS41	199904966	2,823	C
2.9-8	145-mm API BS41	199904967	2,835	C
2.9-8	0.50-cal. AP M2	199904987	3,060	P
2.9-8	0.50-cal. AP M2	199904993	3,072	P
2.9-8	0.50-cal. AP M2	199904983	3,074	P
2.9-8	0.50-cal. AP M2	199904985	3,078	P
2.9-8	0.50-cal. AP M2	199904982	3,098	C
2.9-8	0.50-cal. AP M2	199904976	3,111	P
2.9-8	0.50-cal. AP M2	199904994	3,112	C
2.9-8	0.50-cal. AP M2	199904981	3,187	C
2.9-8	0.50-cal. AP M2	199904980	3,289	C
2.9-8	0.50-cal. AP M2	199904979	3,457	C
2.9-9	145-mm API BS41	199905058	2,755	P
2.9-9	145-mm API BS41	199905065	2,766	P
2.9-9	145-mm API BS41	199905066	2,766	P
2.9-9	145-mm API BS41	199905067	2,776	P
2.9-9	145-mm API BS41	199905059	2,795	P
2.9-9	145-mm API BS41	199905063	2,800	C
2.9-9	145-mm API BS41	199905064	2,800	C
2.9-9	145-mm API BS41	199905062	2,806	C
2.9-9	145-mm API BS41	199905060	2,817	C
2.9-9	145-mm API BS41	199905061	2,830	C
2.9-9	0.50-cal. AP M2	199905048	3,066	P
2.9-9	0.50-cal. AP M2	199905049	3085	P
2.9-9	0.50-cal. AP M2	199905051	3,094	P
2.9-9	0.50-cal. AP M2	199905052	3,106	P
2.9-9	0.50-cal. AP M2	199905053	3,121	P
2.9-9	0.50-cal. AP M2	199905050	3,125	P
2.9-9	0.50-cal. AP M2	199905047	3,128	C
2.9-9	0.50-cal. AP M2	199905055	3,180	C
2.9-9	0.50-cal. AP M2	199905057	3,185	C
2.9-9	0.50-cal. AP M2	199905054	3,187	C
2.9-9	0.50-cal. AP M2	199905056	3,197	C
3.1-1	145-mm API BS41	199905068	2,825	P
3.1-1	145-mm API BS41	199905070	2,886	P
3.1-1	145-mm API BS41	199905071	2,889	P

^a D is disallowed.

Table B-1. Individual Test Shots for Developing the V₅₀ Acceptance Tables (Continued)

Sample No.	Projectile	Round	Striking Velocity	Penetration
3.1-1	145-mm API BS41	199905077	2,904	P
3.1-1	145-mm API BS41	199905076	2,919	C
3.1-1	145-mm API BS41	199905072	2,936	P
3.1-1	145-mm API BS41	199905075	2,939	C
3.1-1	145-mm API BS41	199905073	2,945	C
3.1-1	145-mm API BS41	199905069	2,968	C
3.1-1	145-mm API BS41	199905074	2,982	C
3.1-2	145-mm API BS41	199905332	2,892	P
3.1-2	145-mm API BS41	199905334	2,914	P
3.1-2	145-mm API BS41	199905329	2,917	P
3.1-2	145-mm API BS41	199905333	2,923	P
3.1-2	145-mm API BS41	199905331	2,934	C
3.1-2	145-mm API BS41	199905336	2,940	P
3.1-2	145-mm API BS41	199905330	2,947	C
3.1-2	145-mm API BS41	199905335	2,954	C
3.1-2	145-mm API BS41	199905328	3,018	C
3.1-2	145-mm API BS41	199905327	3,053	C
3.1-3	145-mm API BS41	199905337	2,890	P
3.1-3	145-mm API BS41	199905340	2,914	P
3.1-3	145-mm API BS41	199905343	2,914	P
3.1-3	145-mm API BS41	199905344	2,921	P
3.1-3	145-mm API BS41	199905342	2,925	C
3.1-3	145-mm API BS41	199905339	2,927	C
3.1-3	145-mm API BS41	199905345	2,932	P
3.1-3	145-mm API BS41	199905346	2,933	C
3.1-3	145-mm API BS41	199905338	2,953	C
3.1-3	145-mm API BS41	199905341	2,963	C
3.1-4	145-mm API BS41	199905355	2,843	P
3.1-4	145-mm API BS41	199905358	2,850	P
3.1-4	145-mm API BS41	199905351	2,891	P
3.1-4	145-mm API BS41	199905347	2,919	P
3.1-4	145-mm API BS41	199905357	2,920	C
3.1-4	145-mm API BS41	199905352	2,922	P
3.1-4	145-mm API BS41	199905349	2,924	C
3.1-4	145-mm API BS41	199905356	2,925	C
3.1-4	145-mm API BS41	199905354	2,926	C
3.1-4	145-mm API BS41	199905350	2,927	C

^a D is disallowed.

Table B-1. Individual Test Shots for Developing the V₅₀ Acceptance Tables (Continued)

Sample No.	Projectile	Round	Striking Velocity	Penetration
3.1-4	145-mm API BS41	199905353	2,928	C
3.1-4	145-mm API BS41	199905348	2,962	C
3.1-5	145-mm API BS41	199905367	2,905	P
3.1-5	145-mm API BS41	199905362	2,909	P
3.1-5	145-mm API BS41	199905359	2,914	P
3.1-5	145-mm API BS41	199905364	2,915	P
3.1-5	145-mm API BS41	199905368	2,920	P
3.1-5	145-mm API BS41	199905369	2,928	C
3.1-5	145-mm API BS41	199905361	2,930	C
3.1-5	145-mm API BS41	199905366	2,941	C
3.1-5	145-mm API BS41	199905365	2,945	C
3.1-5	145-mm API BS41	199905363	2,954	P
3.1-5	145-mm API BS41	199905360	2,955	C
3.1-6	145-mm API BS41	199905377	2,887	P
3.1-6	145-mm API BS41	199905379	2,890	P
3.1-6	145-mm API BS41	199905375	2,895	P
3.1-6	145-mm API BS41	199905374	2,903	C
3.1-6	145-mm API BS41	199905376	2,906	P
3.1-6	145-mm API BS41	199905370	2,920	P
3.1-6	145-mm API BS41	199905373	2,929	C
3.1-6	145-mm API BS41	199905378	2,932	C
3.1-6	145-mm API BS41	199905371	2,943	C
3.1-6	145-mm API BS41	199905372	2,945	C
3.1-7	145-mm API BS41	199905380	2,921	P
3.1-7	145-mm API BS41	199905389	2,924	P
3.1-7	145-mm API BS41	199905387	2,925	C
3.1-7	145-mm API BS41	199905384	2,928	P
3.1-7	145-mm API BS41	199905388	2,932	C
3.1-7	145-mm API BS41	199905383	2,935	P
3.1-7	145-mm API BS41	199905382	2,955	P
3.1-7	145-mm API BS41	199905381	2,958	C
3.1-7	145-mm API BS41	199905385	2,981	C
3.1-7	145-mm API BS41	199905386	2,985	C
3.1-8	145-mm API BS41	199905393	2,902	P
3.1-8	145-mm API BS41	199905398	2,906	P
3.1-8	145-mm API BS41	199905399	2,906	P
3.1-8	145-mm API BS41	199905397	2,910	P

* D is disallowed.

Table B-1. Individual Test Shots for Developing the V₅₀ Acceptance Tables (Continued)

Sample No.	Projectile	Round	Striking Velocity	Penetration
3.1-8	145-mm API BS41	199905391	2,920	P
3.1-8	145-mm API BS41	199905395	2,924	C
3.1-8	145-mm API BS41	199905392	2,929	C
3.1-8	145-mm API BS41	199905394	2,940	C
3.1-8	145-mm API BS41	199905396	2,943	C
3.1-8	145-mm API BS41	199905390	2,956	C
3.1-9	145-mm API BS41	199905409	2,912	P
3.1-9	145-mm API BS41	199905403	2,915	P
3.1-9	145-mm API BS41	199905402	2,920	C
3.1-9	145-mm API BS41	199905406	2,928	P
3.1-9	145-mm API BS41	199905404	2,930	C
3.1-9	145-mm API BS41	199905405	2,932	P
3.1-9	145-mm API BS41	199905400	2,934	P
3.1-9	145-mm API BS41	199905407	2,948	C
3.1-9	145-mm API BS41	199905401	2,955	C
3.1-9	145-mm API BS41	199905408	2,956	C
4-1	145-mm API BS41	199905706	3,152	P
4-1	145-mm API BS41	199905707	3,237	P
4-1	145-mm API BS41	199905713	3,293	P
4-1	145-mm API BS41	199905712	3,299	P
4-1	145-mm API BS41	199905710	3,303	P
4-1	145-mm API BS41	199905717	3,307	P
4-1	145-mm API BS41	199905716	3,308	C
4-1	145-mm API BS41	199905715	3,314	C
4-1	145-mm API BS41	199905714	3,320	C
4-1	145-mm API BS41	199905711	3,323	C
4-1	145-mm API BS41	199905718	3,324	P
4-1	145-mm API BS41	199905709	3,347	C
4-1	145-mm API BS41	199905708	3,405	C
4-2	145-mm API BS41	199905724	3,264	P
4-2	145-mm API BS41	199905726	3,265	P
4-2	145-mm API BS41	199905725	3,270	P
4-2	145-mm API BS41	199905723	3,271	P
4-2	145-mm API BS41	199905722	3,288	C
4-2	145-mm API BS41	199905729	3,292	P
4-2	145-mm API BS41	199905727	3,295	P
4-2	145-mm API BS41	199905721	3,315	C

^a D is disallowed.

Table B-1. Individual Test Shots for Developing the V₅₀ Acceptance Tables (Continued)

Sample No.	Projectile	Round	Striking Velocity	Penetration
4-2	145-mm API BS41	199905728	3,318	C
4-2	145-mm API BS41	199905720	3,331	C
4-2	145-mm API BS41	199905719	3,360	C
4-3	145-mm API BS41	199905739	3,256	P
4-3	145-mm API BS41	199905740	3,267	P
4-3	145-mm API BS41	199905743	3,272	P
4-3	145-mm API BS41	199905741	3,279	P
4-3	145-mm API BS41	199905742	3,280	P
4-3	145-mm API BS41	199905738	3,298	C
4-3	145-mm API BS41	199905735	3,300	P
4-3	145-mm API BS41	199905733	3,339	C
4-3	145-mm API BS41	199905737	3,347	C
4-3	145-mm API BS41	199905736	3,348	C
4-3	145-mm API BS41	199905731	3,353	P
4-3	145-mm API BS41	199905734	3,353	C
4-3	145-mm API BS41	199905732	3,367	C
4-3	145-mm API BS41	199905730	3,384	C
4-4	145-mm API BS41	199905745	3,282	P
4-4	145-mm API BS41	199905744	3,290	P
4-4	145-mm API BS41	199905746	3,320	P
4-4	145-mm API BS41	199905753	3,323	P
4-4	145-mm API BS41	199905751	3,335	C
4-4	145-mm API BS41	199905752	3,341	C
4-4	145-mm API BS41	199905748	3,343	P
4-4	145-mm API BS41	199905749	3,348	C
4-4	145-mm API BS41	199905747	3,353	C
4-4	145-mm API BS41	199905750	3,358	C
4-5	145-mm API BS41	199905763	3,292	P
4-5	145-mm API BS41	199905762	3,294	P
4-5	145-mm API BS41	199905764	3,306	P
4-5	145-mm API BS41	199905761	3,326	C
4-5	145-mm API BS41	199905755	3,335	P
4-5	145-mm API BS41	199905760	3,336	C
4-5	145-mm API BS41	199905759	3,346	C
4-5	145-mm API BS41	199905754	3,353	P
4-5	145-mm API BS41	199905758	3,353	C
4-5	145-mm API BS41	199905757	3,380	C

^a D is disallowed.

Table B-1. Individual Test Shots for Developing the V₅₀ Acceptance Tables (Continued)

Sample No.	Projectile	Round	Striking Velocity	Penetration
4-5	145-mm API BS41	199905756	3,383	C
4-6	145-mm API BS41	199905771	3,324	P
4-6	145-mm API BS41	199906064	3,332	P
4-6	145-mm API BS41	199905770	3,336	C
4-6	145-mm API BS41	199906065	3,337	P
4-6	145-mm API BS41	199905765	3,338	P
4-6	145-mm API BS41	199906066	3,353	C
4-6	145-mm API BS41	199905769	3,380	C
4-6	145-mm API BS41	199905767	3,383	C
4-6	145-mm API BS41	199905766	3,384	P
4-6	145-mm API BS41	199905768	3,404	C
4-7	145-mm API BS41	199906057	2,761	D
4-7	145-mm API BS41	199906061	3,255	P
4-7	145-mm API BS41	199906063	3,267	P
4-7	145-mm API BS41	199906060	3,285	C
4-7	145-mm API BS41	199905775	3,288	P
4-7	145-mm API BS41	199906062	3,294	C
4-7	145-mm API BS41	199905774	3,295	P
4-7	145-mm API BS41	199906059	3,295	C
4-7	145-mm API BS41	199906056	3,304	C
4-7	145-mm API BS41	199906058	3,313	C
4-7	145-mm API BS41	199905776	3,325	P
4-7	145-mm API BS41	199905777	3,327	C
4-7	145-mm API BS41	199906054	3,329	C
4-7	145-mm API BS41	199906052	3,334	C
4-7	145-mm API BS41	199906053	3,336	C
4-7	145-mm API BS41	199906055	3,339	C
4-7	145-mm API BS41	199905773	3,353	C
4-7	145-mm API BS41	199905772	3,354	C
4-7	145-mm API BS41	199906051	3,356	C
4-8	145-mm API BS41	199906047	3,265	P
4-8	145-mm API BS41	199905784	3,315	P
4-8	145-mm API BS41	199905783	3,350	C
4-8	145-mm API BS41	199906049	3,355	P
4-8	145-mm API BS41	199905778	3,356	P
4-8	145-mm API BS41	199905780	3,357	P
4-8	145-mm API BS41	199905782	3,367	C

^a D is disallowed.

Table B-1. Individual Test Shots for Developing the V_{50} Acceptance Tables (Continued)

4-8	145-mm API BS41	199906050	3,370	C
4-8	145-mm API BS41	199905781	3,373	C
4-8	145-mm API BS41	199905779	3,388	C
4-8	145-mm API BS41	199906048	3,416	C

^a D is disallowed.

INTENTIONALLY LEFT BLANK.

<u>NO. OF COPIES</u>	<u>ORGANIZATION</u>	<u>NO. OF COPIES</u>	<u>ORGANIZATION</u>
2	DEFENSE TECHNICAL INFORMATION CENTER DTIC DDA 8725 JOHN J KINGMAN RD STE 0944 FT BELVOIR VA 22060-6218	1	DIRECTOR US ARMY RESEARCH LAB AMSRL DD 2800 POWDER MILL RD ADELPHI MD 20783-1197
1	HQDA DAMO FDT 400 ARMY PENTAGON WASHINGTON DC 20310-0460	1	DIRECTOR US ARMY RESEARCH LAB AMSRL CI AI R (RECORDS MGMT) 2800 POWDER MILL RD ADELPHI MD 20783-1145
1	OSD OUSD(A&T)/ODDDR&E(R) R J TREW THE PENTAGON WASHINGTON DC 20301-7100	3	DIRECTOR US ARMY RESEARCH LAB AMSRL CI LL 2800 POWDER MILL RD ADELPHI MD 20783-1145
1	DPTY CG FOR RDA US ARMY MATERIEL CMD AMCRDA 5001 EISENHOWER AVE ALEXANDRIA VA 22333-0001	1	DIRECTOR US ARMY RESEARCH LAB AMSRL CI AP 2800 POWDER MILL RD ADELPHI MD 20783-1197
1	INST FOR ADVNCD TCHNLGY THE UNIV OF TEXAS AT AUSTIN PO BOX 202797 AUSTIN TX 78720-2797		<u>ABERDEEN PROVING GROUND</u>
1	DARPA B KASPAR 3701 N FAIRFAX DR ARLINGTON VA 22203-1714	4	DIR USARL AMSRL CI LP (BLDG 305)
1	US MILITARY ACADEMY MATH SCI CTR OF EXCELLENCE MADN MATH MAJ HUBER THAYER HALL WEST POINT NY 10996-1786		
1	DIRECTOR US ARMY RESEARCH LAB AMSRL D D R SMITH 2800 POWDER MILL RD ADELPHI MD 20783-1197		

<u>NO. OF COPIES</u>	<u>ORGANIZATION</u>
3	PM CRUSADER MOBILITY SYSTEMS PDT D ROARK MS 436 10 42 38500 MOUND RD STERLING HEIGHTS MI 48310
1	PM CRUSADER SYSTEMS INTEGRATION HARDWARE DIV SFAE GCSS CR E B SANVILLE PICATINNY ARSENAL NJ 07806-5000
2	US ARMY TACOM TARDEC LIGHTWEIGHT STRUCTURES TM AMSTA TR R D OSTBERG WARREN MI 48397-5000
1	US ARMY TACOM TARDEC ADVANCED CONCEPTS AMSTA TR S S KARKKAINEN MS 207 WARREN MI 48397-5000
1	US ARMY TACOM TARDEC ENGRNG BUSINESS GP AMSTA TR E OSCR J FLORENCE MS 267 WARREN MI 48397-5000

ABERDEEN PROVING GROUND

30	DIR USARL AMSRL WM MD S GREND AHL
----	---

REPORT DOCUMENTATION PAGE			Form Approved OMB No. 0704-0188	
Public reporting burden for this collection of information is estimated to average 1 hour per response, including the time for reviewing instructions, searching existing data sources, gathering and maintaining the data needed, and completing and reviewing the collection of information. Send comments regarding this burden estimate or any other aspect of this collection of information, including suggestions for reducing this burden, to Washington Headquarters Services, Directorate for Information Operations and Reports, 1215 Jefferson Davis Highway, Suite 1204, Arlington, VA 22202-4302, and to the Office of Management and Budget, Paperwork Reduction Project(0704-0188), Washington, DC 20503.				
1. AGENCY USE ONLY (Leave blank)		2. REPORT DATE April 2001	3. REPORT TYPE AND DATES COVERED Final, October 1998-June 1999	
4. TITLE AND SUBTITLE Mechanical and Ballistic Data for A12519 Plate, Forgings, and Weldments			5. FUNDING NUMBERS TU9A9F111ANU	
6. AUTHOR(S) Scott M. Grendahl, Richard J. Squillacioti, Daniel J. Snoha, and Christopher E. Miller				
7. PERFORMING ORGANIZATION NAME(S) AND ADDRESS(ES) U.S. Army Research Laboratory ATTN: AMSRL-WM-MD Aberdeen Proving Ground, MD 21005-5066			8. PERFORMING ORGANIZATION REPORT NUMBER ARL-TR-2452	
9. SPONSORING/MONITORING AGENCY NAMES(S) AND ADDRESS(ES) U.S. Army Tank-automotive and Armaments Command Heavy Combat Commodity Business Unit, ATTN: AMSTA-LC-CA Warren, MI 48397-5000			10. SPONSORING/MONITORING AGENCY REPORT NUMBER	
11. SUPPLEMENTARY NOTES				
12a. DISTRIBUTION/AVAILABILITY STATEMENT Approved for public release; distribution is unlimited.			12b. DISTRIBUTION CODE	
13. ABSTRACT (Maximum 200 words) The development and potential use of aluminum-armor alloys in the design and construction of combat vehicles has been repeatedly scrutinized as the military continually pushes toward lightweight, mobile, and more deployable forces. In doing so, it is necessary to fully characterize and understand the engineering material properties and the ballistic resistance of any prospective material. Aluminum 2519 (A12519) was developed nearly 20 years ago as a high-strength, heat-treatable alloy with excellent ballistic performance. This alloy was not utilized extensively beyond the experimental phase and as such has not been continually produced by the aluminum industry. Therefore, when the utilization of this alloy recently became expected, questions arose about the ability of the suppliers to reproduce the same product that had been developed in the past. As part of the ensuing analysis, the engineering properties and the chemical and ballistic resistance of the alloy required validation. Additionally, work needed to be performed to verify that the alloy and its various heat treatments were feasible for joining in the construction of armored vehicles. Several common heat treatments were characterized, in addition to the most common weld joints presently designed by Team Crusader.				
14. SUBJECT TERMS aluminum, 2519, fatigue, weldments			15. NUMBER OF PAGES 82	
			16. PRICE CODE	
17. SECURITY CLASSIFICATION OF REPORT UNCLASSIFIED	18. SECURITY CLASSIFICATION OF THIS PAGE UNCLASSIFIED	19. SECURITY CLASSIFICATION OF ABSTRACT UNCLASSIFIED	20. LIMITATION OF ABSTRACT UL	

INTENTIONALLY LEFT BLANK.

USER EVALUATION SHEET/CHANGE OF ADDRESS

This Laboratory undertakes a continuing effort to improve the quality of the reports it publishes. Your comments/answers to the items/questions below will aid us in our efforts.

- 1. ARL Report Number/Author ARL-TR-2452 (Grendahl) Date of Report April 2001
- 2. Date Report Received _____
- 3. Does this report satisfy a need? (Comment on purpose, related project, or other area of interest for which the report will be used.) _____

- 4. Specifically, how is the report being used? (Information source, design data, procedure, source of ideas, etc.) _____

- 5. Has the information in this report led to any quantitative savings as far as man-hours or dollars saved, operating costs avoided, or efficiencies achieved, etc? If so, please elaborate. _____

- 6. General Comments. What do you think should be changed to improve future reports? (Indicate changes to organization, technical content, format, etc.) _____

CURRENT ADDRESS	_____
	Organization
	Name _____ E-mail Name _____
	Street or P.O. Box No. _____
	City, State, Zip Code _____

7. If indicating a Change of Address or Address Correction, please provide the Current or Correct address above and the Old or Incorrect address below.

OLD ADDRESS	_____
	Organization
	Name _____
	Street or P.O. Box No. _____
	City, State, Zip Code _____

(Remove this sheet, fold as indicated, tape closed, and mail.)
(DO NOT STAPLE)