

REPORT DOCUMENTATION PAGE			Form Approved OMB No. 0704-0188		
Public reporting burden for this collection of information is estimated to average 1 hour per response, including the time for reviewing instructions, searching existing data sources, gathering and maintaining the data needed, and completing and reviewing this collection of information. Send comments regarding this burden estimate or any other aspect of this collection of information, including suggestions for reducing this burden, to Department of Defense, Washington Headquarters Services, Directorate for Information Operations and Reports (0704-0188), 1215 Jefferson Davis Highway, Suite 1204, Arlington, VA 22202-4302. Respondents should be aware that notwithstanding any other provision of law, no person shall be subject to any penalty for failing to comply with a collection of information if it does not display a currently valid OMB control number. PLEASE DO NOT RETURN YOUR FORM TO THE ABOVE ADDRESS.					
1. REPORT DATE		2. REPORT TYPE Paper and Viewgraphs	3. DATES COVERED		
4. TITLE AND SUBTITLE  Corrosion and Fatigue Research – Structural Issues and Relevance to Naval Aviation			5a. CONTRACT NUMBER		
			5b. GRANT NUMBER		
			5c. PROGRAM ELEMENT NUMBER		
6. AUTHOR(S)  Margery E. Hoffman; Paul C. Hoffman			5d. PROJECT NUMBER		
			5e. TASK NUMBER		
			5f. WORK UNIT NUMBER		
7. PERFORMING ORGANIZATION NAME(S) AND ADDRESS(ES)  Naval Air Warfare Center Aircraft Division 22347 Cedar Point Road, Unit #6 Patuxent River, Maryland 20670-1161			8. PERFORMING ORGANIZATION REPORT NUMBER		
9. SPONSORING/MONITORING AGENCY NAME(S) AND ADDRESS(ES)			10. SPONSOR/MONITOR'S ACRONYM(S)		
			11. SPONSOR/MONITOR'S REPORT NUMBER(S)		
12. DISTRIBUTION/AVAILABILITY STATEMENT Approved for public release; distribution is unlimited.					
13. SUPPLEMENTARY NOTES					
14. ABSTRACT  The sea environment is the most structurally hostile of environments within which aircraft operate. Naval aviation operations routinely expose structural components to salt spray and high loads, especially during landings. The result in component lives occasionally end prematurely due to corrosion-assisted fatigue, or fatigue with other compounding factors. The occurrences of these unplanned events increase with the number of years an aircraft remains in service. The susceptibility of aging aircraft to structural demise demands that we institute a paradigm shift to our approach to designing, maintaining, and managing metallic aircraft structures subjects to repetitive loads and corrosive environment. Is corrosion and fatigue research heading in the right direction to solve real and potential problems in aging naval aircraft?  This paper provides an overview of how we validate and assess service life. The key issues involved in managing life-critical parts during their operation are the adjusting of inspections, and the effect of operational discoveries of flaws or failures, which disrupt our perceptions of the structural condition, on total life designation. The management issues with respect to an aging operation fleet of naval aircraft will be described from the view of the structural life management team. Research in corrosion and fatigue of metals must answer to the tactical aircraft manager's need. For structures and materials research to transition into practice, it must focus on producing data and test results useful for making life decisions.					
15. SUBJECT TERMS Fatigue; Corrosion; Prediction; Military; Aircraft					
16. SECURITY CLASSIFICATION OF:			17. LIMITATION OF ABSTRACT	18. NUMBER OF PAGES  24	19a. NAME OF RESPONSIBLE PERSON Margery Hoffman; Paul Hoffman
a. REPORT	b. ABSTRACT	c. THIS PAGE			19b. TELEPHONE NUMBER (include area code) (301) 757-6433 / 342-9361

Standard Form 298 (Rev. 8-98)  
Prescribed by ANSI Std. Z39-18

20010426 104

1997

## Corrosion and Fatigue Research - Structural Issues and Relevance to Naval Aviation

Margery E. Hoffman, Paul C. Hoffman

*Naval Air Warfare Center – Aircraft Division, Structures Division Building 2187, Suite 2320A,  
48110 Shaw Road, Unit 5, Patuxent River, MD 20670-1906 Tel: 301-757-6433 Fax: 301-757-6158,*

*Email: [HoffmanME@navair.navy.mil](mailto:HoffmanME@navair.navy.mil); [HoffmanPC@navair.navy.mil](mailto:HoffmanPC@navair.navy.mil)*

### Abstract

The sea environment is the most structurally hostile of environments within which aircraft operate. Naval aviation operations routinely expose structural components to salt spray and high loads, especially during landings. The result is component lives occasionally end prematurely due to corrosion-assisted fatigue, or fatigue with other compounding factors. The occurrences of these unplanned events increase with the number of years an aircraft remains in service. The susceptibility of aging aircraft to structural demise demands that we institute a paradigm shift to our approach to designing, maintaining and managing metallic aircraft structures subjects to repetitive loads and corrosive environment. Is corrosion and fatigue research heading in the right direction to solve real and potential problems in aging naval aircraft?

This paper provides an overview of how we validate and assess service life. The key issues involved in managing life-critical parts during their operation are the adjusting of inspections, and the effect of operational discoveries of flaws or failures, which disrupt our perceptions of the structural condition, on total life designation. The management issues with respect to an aging operation fleet of naval aircraft will be described from the view of the structural life management team. Research in corrosion and fatigue of metals must answer to the tactical aircraft manager's needs. For structures and materials research to transition into practice, it must focus on producing data and test results useful for making life decisions.

*Keywords:* Fatigue; Corrosion; Prediction; Military; Aircraft

### Introduction

US Navy aircraft are required to withstand randomly occurring fatigue loading during their design service life without visibly cracking, because of the austere operational realities of the Navy's mission. The US Navy operates aircraft from floating bases, with run-ways 1/10 the length of land-based runways, perform missions at altitudes barely above sea level, and are on deployment, away from maintenance hangars, for months on end. Due to mission demands, the structural integrity management objectives of safety and readiness must be achieved within two

operational constraints. First, a carrier has a limited total deck area. Second, a carrier must maintain a broad theater of operations. Hence, from an airframe integrity perspective the constraints rule out routine inspections for fatigue cracks, and consequently crack initiation becomes the basis for life management.

At the forefront policy for naval aircraft is the preservation of flight safety throughout the entire service lifetime. Flight safety is the cornerstone of all structural management plans. After safety has been assured, the next priority is readiness. Readiness demands that integrity be designed into the structure up front, so maintenance demands are minimized, and inspections are not routinely relied upon for safety. Cracking should not be an issue when it's time for the aircraft to perform its mission. The challenge is to design airframes that will last a lifetime, to predict fatigue damage before it happens, and to recognize it when it does.

Consequently, a Safe-Life approach has been used to design all Navy aircraft to withstand fatigue loading. Furthermore, a strain-life fatigue algorithm is used to predict the occurrence of crack initiation on every airframe individually, based on structural data recorded aboard the aircraft. In the next few paragraphs, we will define the Safe-Life approach from the Navy perspective, and we will discuss the significance of using a factor of uncertainty of two. We will point out how the presence of corrosion has affected our fleet, in terms of safety, readiness and maintenance, and why we have come to prioritize corrosion and fatigue problems with respect to 1) flight safety, 2) readiness and 3) return on investment (ROI).

## **Background**

There are basically two different approaches to the structural management of load-bearing metallic components in airframes. The first predicts crack initiation, and the second, crack growth. Designs based on crack initiation are known as safe-life, those based on crack growth are known as damage tolerance. The US Navy has adopted a safe-life approach for the aforementioned reasons, and especially because of the possibility of the lack of accessibility to the structure during carrier deployment for routine maintenance and repair. The US Air Force uses a damage tolerance approach to schedule inspections. They have ready access to their fleet, and rely on the results of nondestructive inspections to attain and extend life. Both methods have served their respective services well.

## **The Naval Aviation Approach to Fatigue Life Prediction**

There are two activities associated with fatigue life predictions. The first is the assignment of service life and validation by the full-scale fatigue test. The second is the individual fatigue-tracking program that collects data and performs fatigue predictions quarterly for every fatigue critical component of over 3500 airframes in the Navy and Marine Corp inventory.

## Service Life

Service life limits are established for an aircraft based on operational requirements, design criteria, technical analysis and fatigue test results. Ninety percent of all aircraft are expected to obtain service life without cracking [1]. In the simplest of terms, testing an early production aircraft to a severe flight-by-flight loading until it fails or extensive micro cracking occurs validates the service life. The cracks are inspected fractographically and the equivalent flight hours to a crack length of 0.01in. [0.25 mm] are recorded. This is nominally the time-to-crack-initiation. Failure is defined as the time to reach a 0.01 in. [0.25 mm] crack.

For each critical cracking location, the time for a crack to form and propagate to 0.01 in. [0.25 mm] during the full-scale fatigue test is divided by two to obtain the component service life. For critical locations that have not cracked, the time (equivalent flight hours) to the end of the test is divided by two. The factor of two is now known as a factor of uncertainty on life [1]. It is a ratio of the failure life to the desired service life,

$$\text{Factor of Uncertainty} = \text{failure life}/\text{desired service life}$$

where life is a unit of time measured by flight hours, for example. Factors of uncertainty are used to provide a degree of assurance that uncertainties in materials and fabrication will not lead to a premature end of service life.

## The Factor of 2

Full-scale fatigue tests of airframes are very time consuming, (two to five years) and expensive. For this reason, only one full-scale test is conducted and completed. The results are assumed to be the medium of a lognormal distribution of fatigue lives, where life is defined as the time to reach a crack size of 0.01 in. [0.25 mm] at safety-of-flight-critical locations. Next, the acceptable probability of crack initiation ( $P_f$ ) for an aircraft over its lifetime is required by Navy management to be less than or equal to one in one-thousand ( $P_f \leq 0.001$ ). Finally, we assume that the lognormal standard deviation (standard deviation of the log of the variable),  $\sigma$ , is 0.1, interpreted from tests results reported in (Payne[2], Bouchard[3]). These assumptions are summarized in Figure 1.

With these four assumptions in place, the factor of uncertainty can be evaluated, and has been reported in (Payne[2]) as a function of sample size,

$$F.U. = 10^{(z_{\text{spec}})^2 \sigma^2 / (n+1)}$$

where  $z_{\text{spec}}$  is the value from the standard normal table corresponding to the specified  $P_f$ . For a  $P_f = 0.001$  and  $z_{\text{spec}} = 3.08$ ,  $F.U. = 2.032$ .

This relationship was first graphed in Reference 2, and is redrawn, and slightly modified here as Figure 2. For illustrative purposes, three curves are shown in Figure 2, all with  $\sigma = 0.010$ . The middle curve represents a

probability of failure of 0.001, the aforementioned acceptable probability of crack initiation as specified by the US Navy airframe strength management team. Notice that the factor of uncertainty varies from 2.7 for a sample size of one down to a value just greater than two for a sample size of 10 or more. The sample size is the number of specimens or test articles that are tested. The US Navy strength management team accepts an even further reduced factor of uncertainty equal to 2.0, with the testing of just one full-scale test. The reduction from  $FU=2.7$  to  $FU=2.0$  is founded on two thoughts. First, there is a large historical database for fatigue test results. From this long historical engineering experience, the number of samples is extrapolated to approach infinity. Secondly, the required routine maintenance imposed on US Navy airframes provides a supporting measure to ensure the application of  $FU=2.0$  is appropriate. The top curve illustrates the effect on the factor of uncertainty of restricting the tolerance of failure to  $P_f=0.0001$ . For a sample of one, the factor of uncertainty needs to increase to 3.33 to obtain that level of safety, and for an infinite sample size, to a value of 2.5. The lower curve illustrates the relationship with  $P_f = 0.01$ . This curve illustrates that reducing the current factor of uncertainty from 2.0 to 1.8 increases the  $P_f$  an order of magnitude, from 0.001 to 0.01. Other militaries use this same family of curves, and employ factors of 2.7 (Australia) to 3.33 (UK), because of different assumptions of sample size and policies regarding the value of the tolerable probability of failure. Keep in mind that the service life assignment, as described above, is based on the uncertainty in material and structural properties, and does not consider the uncertainty in the operational environment. Uncertainty in loading is considered by using a severe test spectrum when conducting tests.

### **The Test Spectrum**

The most influential input to determining service life from test data is the test spectrum. The test spectrum is constructed from usage curves. Usage is measured by the  $N_z$  exceedances per thousand hours of flight.<sup>1</sup> These curves are constructed from historical data, obtained from accelerometer readings of past and current aircraft that are flying in the same role planned for the new aircraft. The roles, missions, and inventory requirements are known from the design requirements. Military specifications serve as guidance to formulating conservative flight-by-flight spectra from the  $N_z$  data [1, 4-7]. The current guidance, relevant to the JSF aircraft, is simply that the test spectrum shall represent the service life and usage adjusted for historical data, potential weight growth and future aircraft

---

<sup>1</sup>  $N_z$  is the acceleration of the aircraft in the z direction, which is normal to the aircraft's longitudinal axis. An exceedance is a cumulative sum of occurrences reported at several acceleration levels, relative to the acceleration due to gravity. The units of  $N_z$  are "g's". The acceleration due to gravity = 1.0 g.

performance. Ninety percent of the fleet, operating at the test spectrum will be expected to meet the service life. This guidance is met by developing a spectrum that represents at least 90% of the expected fleet usage during the operational service life. The ninetieth percentile relevant to a normal distribution is the mean plus 1.32 times the standard deviation ( $\mu+1.32\sigma$ ). Figure 3 illustrates how the sequential stress peaks and valleys that make up the test spectrum are derived from operational exceedance<sup>2</sup> data. Current operational aircraft, e.g., the F/A-18 C/D, were tested to a spectrum that represented the mean plus 3.0 times the standard deviation ( $\mu+3.0\sigma$ ) of the usage distribution. The new joint performance specification is less restrictive due to better notions of usage. Until the design and testing of the F/A-18E/F, the test spectra criteria were more severe. The severity was necessary because there were many unknowns about the use and performance of the designed. The newest acquisitions, F/A-18E/F and JSF, are incrementally less different in performance and anticipated usage than the aircraft that they replace, relative to the F-14 and F/A-18 A/B/C/D aircraft and the aircraft they replaced.

### **The Fatigue Algorithm**

Fatigue predictions are updated from operational flight data on most Navy and Marine fixed-wing air vehicles. Fatigue damage is reported as the fatigue life expended, (FLE), an index relative to the test flight hours it took to form 0.01 in. [0.25 mm] cracks. FLEs are calculated at five to nine locations for fighter/attack aircraft and twenty to thirty locations for patrol and support aircraft. FLEs are used to schedule maintenance and retirements, and in life assessment and life extension programs.

The strain-life approach is used to predict when 0.01 in. [0.25 mm] cracks will form at critical locations on the airframe. Strain-life was first used to predict crack initiation on the F/A-18 aircraft in the 1980s. It is now the standard of all FLE calculations. The strain-life method models the response of material at notches or other stress risers. When loads are low, stresses are elastic, and stress and strains are linearly related. As load levels rise, material near a notch responds plastically to relieve the local stresses. The strain-life method predicts the fatigue damage resulting from the fluctuating local plastic deformation, or strains. In aeronautical structures, the far-field material response remains elastic, while the local response may be plastic.

Strain-life curves are constructed by testing smooth, un-notched, hourglass-shaped specimens in the laboratory until they fail under full-reversed constant amplitude loading. The time to fail the smooth specimens is assumed to

---

<sup>2</sup> An exceedance is a cumulative sum of occurrences reported at several acceleration levels, relative to the acceleration due to gravity, Nz. The units of Nz are "g's".

correlate with the time to form a 0.01 in. [0.25 mm] crack from a fastener hole, under identical loading (Bannantine, Comer, Handrock[8]), Figure 4(a). The assumption of equivalency in damage accumulation between the two cases is considered to be slightly conservative, which makes it a useful assumption. A material database consists of coefficients that describe the strain-life curves for constant amplitude loading, with fully reversed loading (a mean stress of zero). There are two distinct portions of the curve, low-cycle fatigue and high-cycle fatigue, with a transition of the two occurring between  $10^3$  and  $10^4$  cycles. The strain-life curve is defined by adding the effects of two mechanisms together. Total strain amplitude,  $\Delta\epsilon/2$ , is the sum of the elastic and plastic strains:

$$\frac{\Delta\epsilon}{2} = \frac{\sigma'_f}{E} (2N_f)^b + \epsilon'_f (2N_f)^c$$

Where  $N_f$  is the number of cycles to failure, Figure 4(b). When strain amplitude and cycles are plotted on a log-log scale,  $b$  and  $\sigma'_f$  are the slope and intercept respectively of the elastic strain-life relationship and  $c$  and  $\epsilon'_f$  are the slope and intercept respectively of the plastic strain-life relationship. Life,  $2N_f$ , is calculated by this relationship with total strain amplitude inputs as determined from flight recorder data. Additional terms are added to account for mean stress effects for variable amplitude loading that has mean stresses greater than zero.

The advantage of using the strain-life method is that the number of specimens needed to develop the strain-life relationship for the hourglass specimens is significantly less than the number needed to test using the stress-life approach that it replaced. With the stress-life approach, the test matrix needed to include specimens exhibiting a range of stress-concentrations present in the structure. The other advantage is that strain-life consistently handles the sequencing of variable amplitude loads, while stress-life cannot account for load sequence effects. For these reasons, the strain-life approach is attractive to the Navy and manufacturers of aircraft alike.

Strain-life analysis accounts for crack formation and growth to 0.01 in. [0.25 mm]. It does not account for crack growth once a crack had grown longer than 0.01 in. [0.25 mm]. Once a crack is formed, stresses are relieved in the material through crack-tip plasticity and crack propagation. Crack growth models are used to predict life in this stage, if specific aircraft needs a waiver to fly more hours than the strain-life validation. Historically, prior to the end of the "Cold War", life extension was not an issue. However, in the current economical and political environment, scheduled nondestructive inspections are needed on a case-by-case basis to ensure safety and minimize maintenance of land-based aircraft.

## The Structural Appraisal of Fatigue Effects Program

The Structural Appraisal of Fatigue Effects (SAFE) program is the Navy's tool for individually tracking critical locations on airframes, so that service life is maximized. Tracking usage and using it to calculate fatigue damage rather than using a representative or conservative stress history maximizes service life. Stress histories are determined from data collected on aircraft as they perform their missions. Summary data are used to schedule structural modifications, modify operational usage, extend life and retire aircraft. Additionally, usage data are used in designing new aircraft.

Fatigue damage accumulation is reported in a monthly or quarterly SAFE report as an index of damage relative to the full-scale test. The FLE rate is used to project aircraft service life in terms of flight hours. The operational fleets use the SAFE report to project aircraft readiness and schedule maintenance. Poor predictions can lead to decreased readiness, safety, and costly unplanned maintenance.

The FLE tracking process is summarized in Figure 5. The four main elements of tracking are data collection, data reduction, damage calculation, and information dissemination. Load excursions are recorded on the aircraft. Aircraft have accelerometers that record the number of exceedances of a few g-levels the aircraft encounters. New aircraft are delivered with manufacturer-supplied multi-channel recorders. Older aircraft are being retrofitted with the Structural Data Recording Set, SDRS, a generic multi-channel recorder. These recorders allow load excursions to be saved in chronological order for input into the strain-life algorithm. Maintenance crews perform data recovery from individual aircraft. Depending on the air vehicle and recording set, data storage units fill up weekly. Data are sent monthly to Naval Air Systems Command at Patuxent River, where they are received for processing.

After the data are subjected to strict quality control measures, hysteresis loops at the critical locations are constructed (Figure 5a,b). Hysteresis loops, created by plotting local stress versus strain, identify damaging events. The area within a closed loop is the energy per unit volume dissipated during a loading cycle. It represents a measure of the plastic deformation work done on the material [2]. When the ranges and means of the closed loops are assembled from the hysteresis loops, equivalent strain amplitude is calculated and life is found from the strain-life relationship (Figure 5c). The damage fraction for the hysteresis loop is defined as the inverse of cycles to failure,  $1/N_f$ . When life has units of cycles, damage has units of inverse cycles (Figure 5d). The incremental damage is calculated by multiplying each of the  $1/\text{life}$ 's by the number of cycles having the same equivalent strain amplitude and summing them, as represented by the following equation for linear damage accumulation, known as Miner's Rule,

$$\sum_{i=1}^{nt} n_i / N_{fi} = \text{Cumulative Damage}$$

Where  $N_{fi}$  are the individual cycles to failure corresponding to the  $i^{\text{th}}$  discrete group of strain amplitudes present in the counted strain history,  $n_i$  are the number of cycles at the  $i^{\text{th}}$  strain amplitude level, and  $nt$  is the total number of discrete strain amplitude levels. According to Miner's rule, when the cumulative damage equals one, failure is predicted to occur. In applying this rule to naval aviation, failure is defined as the formation of a 0.01-inch crack, based on experience from the full-scale test. This linear damage summation method is widely used in fatigue algorithms, independent of sophistication of their damage equations. Open loops are typically included in the monthly incremental damage as half the damage of a closed loop, and are also saved for closing with future data.

Next the FLE is found by multiplying the cumulative damage by 200% (Figure 5e). This step allows the FLE at 100% to have the equivalent damage as the full-scale test component at half of its life, consistent with applying a factor of uncertainty of two. The FLE is presented as the percentage of life used toward failure. FLE is plotted versus flight hours, and aircraft are nominally retired when FLE= 100% (Figure 6). Recall that time- to- failure is defined as the time it takes to form a 0.01-inch crack. The FLE is the cumulative damage with the factor of uncertainty applied.

Finally, FLE, FLE rates, total flight hours and landings are reported by individual aircraft serial number and published monthly on a floppy disk, or quarterly on paper by aircraft model. Scatter plots of FLE by type, model, and series of aircraft are used to project maintenance and retirement. An example from an F/A-18 quarterly report is presented in Figure 6. These SAFE reports are mailed to the relevant squadron and organizational level personnel for their planning and fleet management. FLE rates are also used by OPNAV to plan readiness levels and procurement needs. The monthly process takes 45 days at best, and the quarterly process takes four months to complete. Near term plans include using secured websites to obtain and disseminate data to reduce turn-around time.

### **The Complications of Aging**

Historically, the FLE-defined end of service life, ESL, was a most economical structural integrity management policy to meet the every changing readiness requirements. In the past, technologies improved which in turn lead to greater aircraft performance levels. Indeed, in the cold war era, end of service life as set by FLE was generally superseded by end of service life as defined by aircraft obsolescence as new adversary aircraft were introduced. Over this period in which end of service was defined by performance obsolescence, the FLE theory was never tested

beyond a fleet FLE average of 80%. Now with the demands for aging aircraft, performance obsolescence is not an issue, and airframe FLE will proceed to 100% and more. The concern is that in the later stages of FLE, greater than approximately 100%, fatigue problems may arise that were never seen in the past. The full-scale fatigue tests found the precursor locations for cracking, the FLE focus, but such tests were conducted with extreme loads. Now if one pushes to higher FLEs, it is feared that failure locations may ensue, which were previously unobserved during full-scale testing, and therefore, unanticipated. Likewise, the aforementioned tracking program indicates the growing sophistication in measuring aircraft usage, loads. As the accountability of aircraft usage improves the underlying conservatism in the FLE tracking program is being reduced. This raises concerns of entering the FLE arena beyond 80%, the shaded area shown with the question mark in Figure 6. In other words, the less sophisticated aircraft usage measurements resulted in more conservative FLE calculations. Now with strain gage recording usage the FLE calculations are deemed more precise creating the net effect of removing some conservatism, as schematically presented in Figure 7. An historic illustration of how flight hours are increased for aircraft using progressively more precise information is shown in Figure 8. The question is then, with each removal of a layer of conservatism, are we getting past the applicability of the FLE approach?

The demand to maintain aging aircraft has engendered some rethinking of the FLE approach. It is envisioned that at some point the FLE method will be subsumed in a total life methodology. Reliability analysis will assess risk with respect to actual component failure versus the FLE crack initiation limit. Current work in the area of total life reliability analysis is underway. Total life is defined as the time for a crack to initiate and grow to 0.01in. [0.25 mm] plus the time to grow from 0.01in. [0.25 mm] to fast fracture. Over the past two decades much work has been done in the area of probabilistic crack growth analysis so that one part of a probabilistic total life formulation is mature. The development of a probabilistic crack initiation life is underway at this time. The randomness of crack initiation time is being quantified through the development of a probabilistic strain-life formulation. The first phase of the program is near completion.

### **The Complications of Corrosion**

Superimposed on the aging problem is the corrosion problem. Corrosion is basically a chronological phenomenon whereas fatigue is a flight hour phenomenon. The average chronological age of naval aircraft is increasing yearly, Figure 9. There are three lines illustrated in Figure 9, the upper line is the average age of all helicopters owned by the US Navy on a yearly basis. The lower line is the average age of all fixed wing aircraft owned by the US Navy on a yearly basis, and the middle line is the weighted average of helicopters and fixed wing

aircraft combined. Note that in the early 1970s that there were more helicopters than fixed wing aircraft in service, and in the 1980s and 1990s that there were more fixed wing aircraft than helicopters. In the past the aforementioned end of service life as defined by performance obsolescence precluded any extensive concern with corrosion. It is only in the later portion of airframe life that corrosion is seen as having a degrading impact. Corrosion maintenance hours per flight hour have increased significantly over the past ten years, Figure 10. From one perspective, the impact is cumulative in that corrosion is removed as it is discovered but it is after several removals that result in a reduction of service life as defined by FLE. With several removals the stress levels are increased which in turn negatively affect service life. From an alternate perspective, even more insidious is the increase in stress concentrations that corrosion pits cause. In the case of pitting, corrosion increases the local strain levels, which result in earlier crack initiation than estimated by FLE.

In all, corrosion is viewed as a safety and readiness problem with substantial cost implications. Because the engineering understanding of corrosion with respect to structural integrity is nil the present maintenance imperative is that when corrosion is discovered it is to be removed. This is a purely reactive maintenance plan and as a consequence extremely costly. This assessment of the practice is borne out by maintenance records. Maintenance hours attributed to corrosion at the Organization, "O", level have increased significantly in the last ten years, Figure 10. In order to change the trend, one must select maintenance options that provide safety and readiness for the least cost among the alternatives. To plan and optimize maintenance actions and scheduling, one must be able to forecast structural degradation. A life prediction method that incorporates not only the effect of fatigue but also corrosion needed. The life prediction model must have measurable metrics for corrosion with respect to structural integrity if one is to plan for corrosion maintenance.

The inevitable is that without a capability to assess the presence of corrosion with respect to structural integrity the maintenance costs will dramatically increase. Corrosion damage accumulates with time, Figure 11. If the trend of increasing cost is to be reversed, maintenance options must have a decision window within which to be applied. At some point in time, the corrosion damage assists fatigue to cause structural failure. Likewise, at some point before the structural failure, maintenance must be done to ensure safety. At present, neither the failure point nor the point for the last chance for timely maintenance is known. Hence, due to a lack of capability to structurally assess corrosion, the present engineering imperative is that when corrosion is found it must be removed. In addition, the problem is soon to be exacerbated by improved NDI techniques that signal the possibility of corrosion at even

earlier timeframes. As NDI gets more sensitive it will give signals earlier and maintenance will be required. In essence, more maintenance will ensue thereby driving up the maintenance expenditures.

To combat the spiraling costs for corrosion maintenance two technical challenges must be met. First a metric, that is, a unit of measurement, must be defined for corrosion with respect to structural integrity. Second, and concurrently, a structural life prediction model, to which the corrosion metric is input, must be developed. The accomplishment of two technical challenges will provide the assessment capability to plan for corrosion by providing a decision window within which maintenance could be scheduled after detection but before the urgency of last minute demands.

### **Summary**

In summary, the research needs with respect to structural integrity management of naval air vehicles have been presented. Fundamentally, the needs center on corrosion and fatigue as two interactive phenomena degrading structural health. While one could point to a myriad of research and development activities for general aviation, the US Navy R&D must be and is centered on the operational requirements of the carrier fleet. Carrier operations prohibit extensive inspection and repair capability aboard the ship. Consequently, the US Navy approach to airframe integrity management has been and will continue to be to manage according to the safe life methodology.

The underpinning of the naval aviation safe life approach is the analysis of fatigue life expended according to the strain-life model. Each naval aircraft is tracked for its specific usage (load spectra per flight) with some platforms tracked to more accuracy and precision than others. The load spectra are the input to the computation of the amount of fatigue life expended as dictated from the strain-life curve analysis. In the earlier tracking experiences the data was very conservative in that load spectra was gleaned for flight parameters which in turn were used to assess the worse case scenarios. The present tracking methods are more sophisticated and the load spectra are more realistic. Consequently the life analysis is more precise which in turn reduces whatever built-in conservatism was originally present. This predicament has led to the R&D requirements for structural reliability and risk assessment methodologies.

During the cold war era, the predominant cause for the removal and replacement of an entire platform was performance obsolescence. Removal and replacement due to obsolescence always occurred much earlier than that which would have been required by the fatigue life expended analysis. Now the table has turned, air vehicles are to be removed and replaced as fatigue life is expended and not because of new performance requirements. This means that the fatigue life expended concept will be tested beyond any limit that was seen prior. The concern is the fact that

many of the factors of safety have been streamlined but never tested historically to the airframe time limits so designated.

Complications abound with the presence of corrosion. The major fear is the clear-cut concern of corrosion-assisted fatigue. Current maintenance practices require the removal of corrosion when it is found. This practice is expensive and perhaps a cause for more rapid life expenditures (pristine material removal) than need be warranted by the actual corrosion present. However, the present removal when detected policy must continue until a metric by which corrosion can be quantified in terms of structural integrity.

#### **Acknowledgements**

The authors would like to gratefully acknowledge Mr. Don Polokovics, of the Tactical Strength and Airframe Technology Branch, for his insightful leadership and many valuable discussions with us. The authors would also like to thank Dr. A. Vasudevan, of the Office of Naval Research for his profound suggestions and continuous encouragement that made this paper a reality.

#### **References**

- [1] Joint Service Guide Specification, Aircraft Structures, General Specifications for, Draft, ASC/ENFS, Wright-Patterson AFB OH 45433-6503 or Naval Air Systems Command/4.3.3, Patuxent River MD 20670-1906, Draft 1997.
- [2] Payne, A.O., Full-scale fatigue testing of Aircraft Structures, Proceedings of the symposium held in Amsterdam, Netherlands, Jun 5-11, 1959, Determination of the Fatigue Resistance of Aircraft Wings by Full-scale Testing, Plantema and Schjiva, eds. Pergamon Press, NY, 1961.
- [3] Bouchard, E. D., "Evaluation of Fatigue Capabilities on High Performance Military Aircraft", McDonnell-Douglas Aircraft Company, 1985.
- [4] NAVAIR 01-1A-13, Fatigue of Aircraft Structures, Naval Air Systems Command, Dept. of the Navy, 1966.
- [5] MIL-A-8861B, Airplane Strength and Rigidity Flight Loads, 5 Dec 1994.
- [6] MIL-A-8866C, Airplane Strength and Rigidity, Reliability Requirements, Repeated Loads, Fatigue, and Damage Tolerance, 3 Oct 1994.
- [7] MIL-A-8867C (AS), Airplane Strength and Rigidity Ground Tests, 3 Oct 1994.
- [8] Bannantine, J. A., Comer, J.J., Handrock, J.L. Chapter 2, "Strain-Life", *Fundamentals of Metal Fatigue Analysis*, Prentice-Hall Inc., Englewood Cliffs, NJ 1990, pp.40-87.

## Captions for Figures

- Figure 1. The four assumptions of Safe Life leading to a factor of two on life.
- Figure 2. Factor of Uncertainty as a function of sample size, for various  $P_f$ s.
- Figure 3. The test spectrum is derived from operational data.
- Figure 4. The strain life concept, axial coupons to strain-life curves.
- Figure 5. The fatigue tracking method.
- Figure 6. Summary of F/A-18 Aircraft Data.
- Figure 7. The effect of more precise FLEs on safety.
- Figure 8. Example of the evolution of recording systems.
- Figure 9. Average age of USN aircraft as a function of years.
- Figure 10. Corrosion trends by fiscal year.
- Figure 11. Management issues with regard to Corrosion Damage.

**a. Fatigue lifetime(crack initiation time) is lognormal**

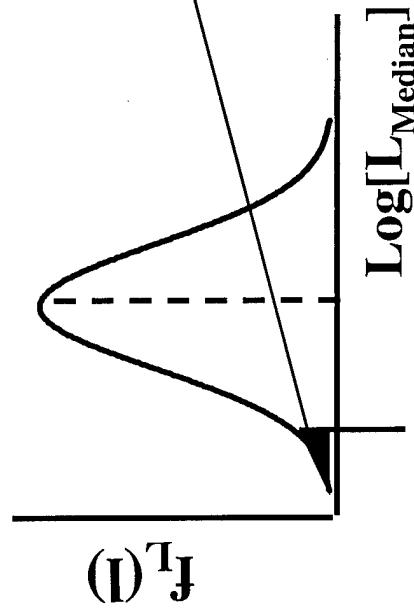

**c.  $P_{\text{crack initiation}} = 0.001$**

**d. Standard Deviation of Log[fatigue life] = 0.10**

$L_{\text{max}} = 1/2 L_{\text{Median}}$   
 $L_{\text{max}} = \text{Service life}$

**b.  $L_{\text{Median}} = \text{Test life to crack initiation, crack size} = 0.01 \text{ inches}$**

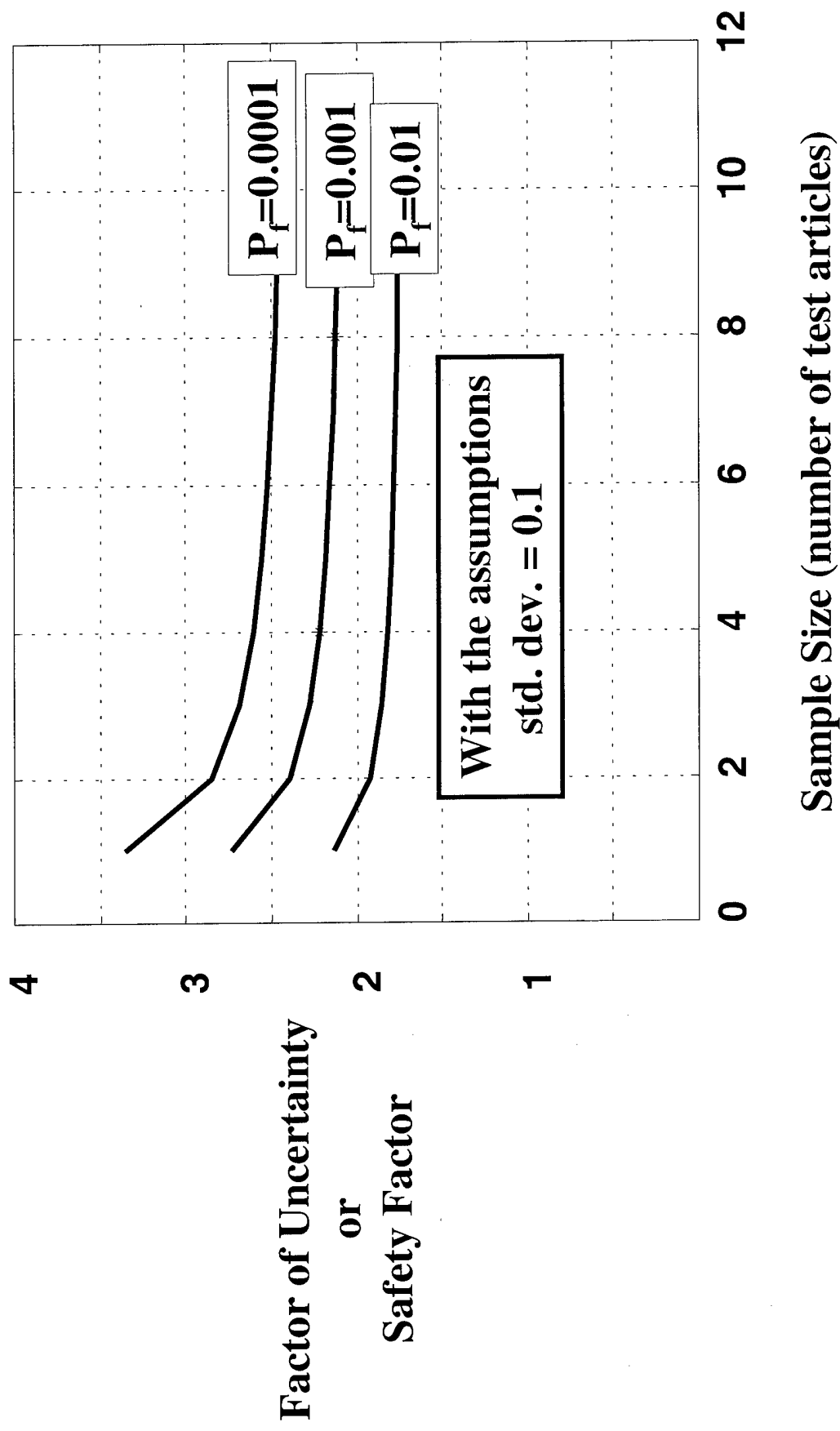

### Testing Procedure

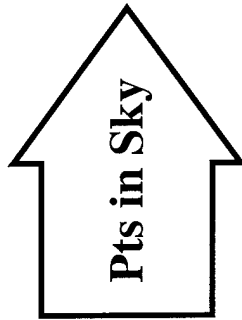
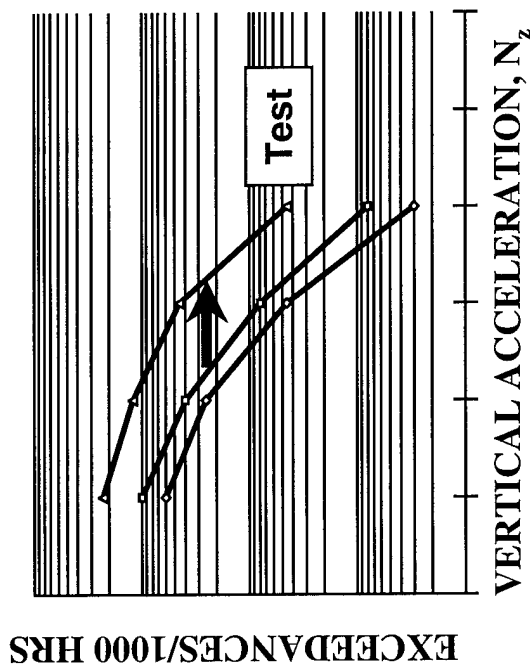

### Severe Test Spectrum

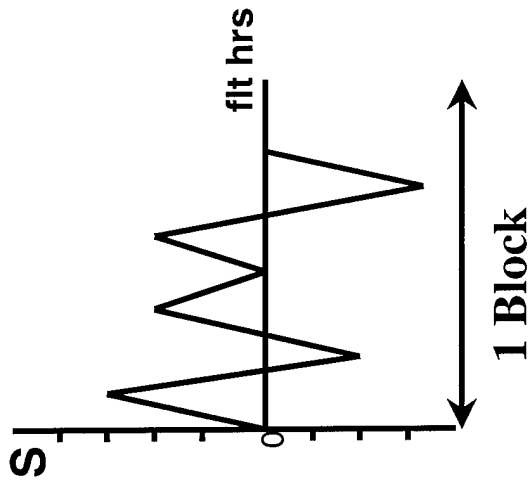

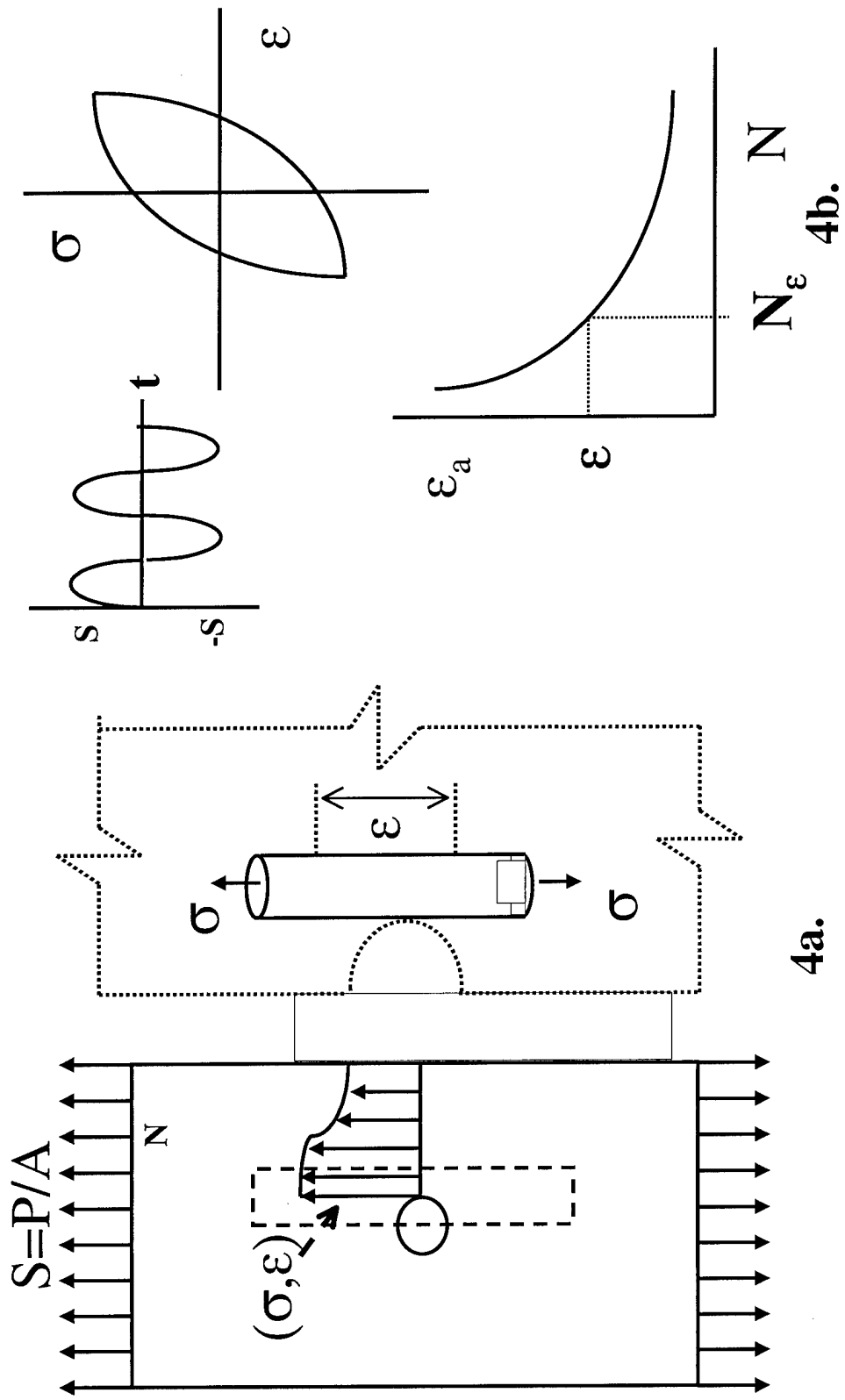

**a. Load Excursion**

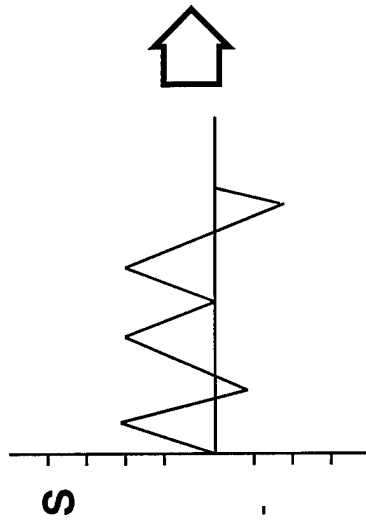

**b. Hysteresis Loops**

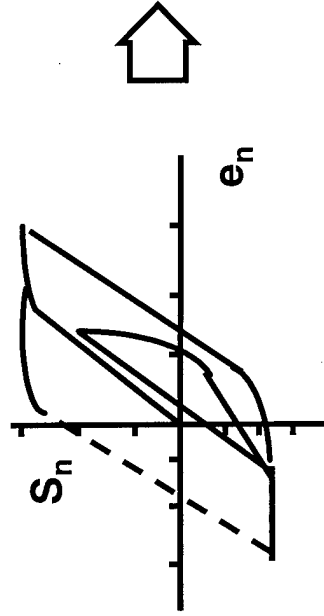

**c. Strain-Life Calc.**

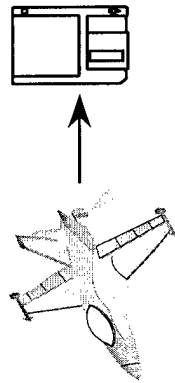
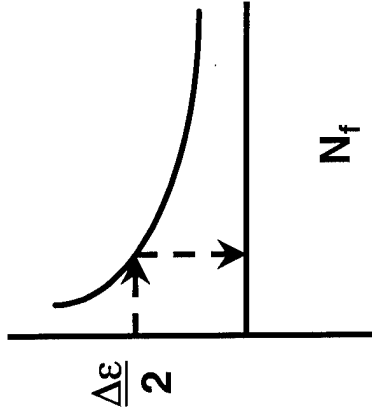

**d. Damage Calc.**  $Damage = \sum \frac{n_i}{N_{fi}} \leq 0.5$

**e. Conversion to FLE**

**FLE = 2 \* Damage \* 100%**

# Scatter Plot of Individual Aircraft as of 2QFY99

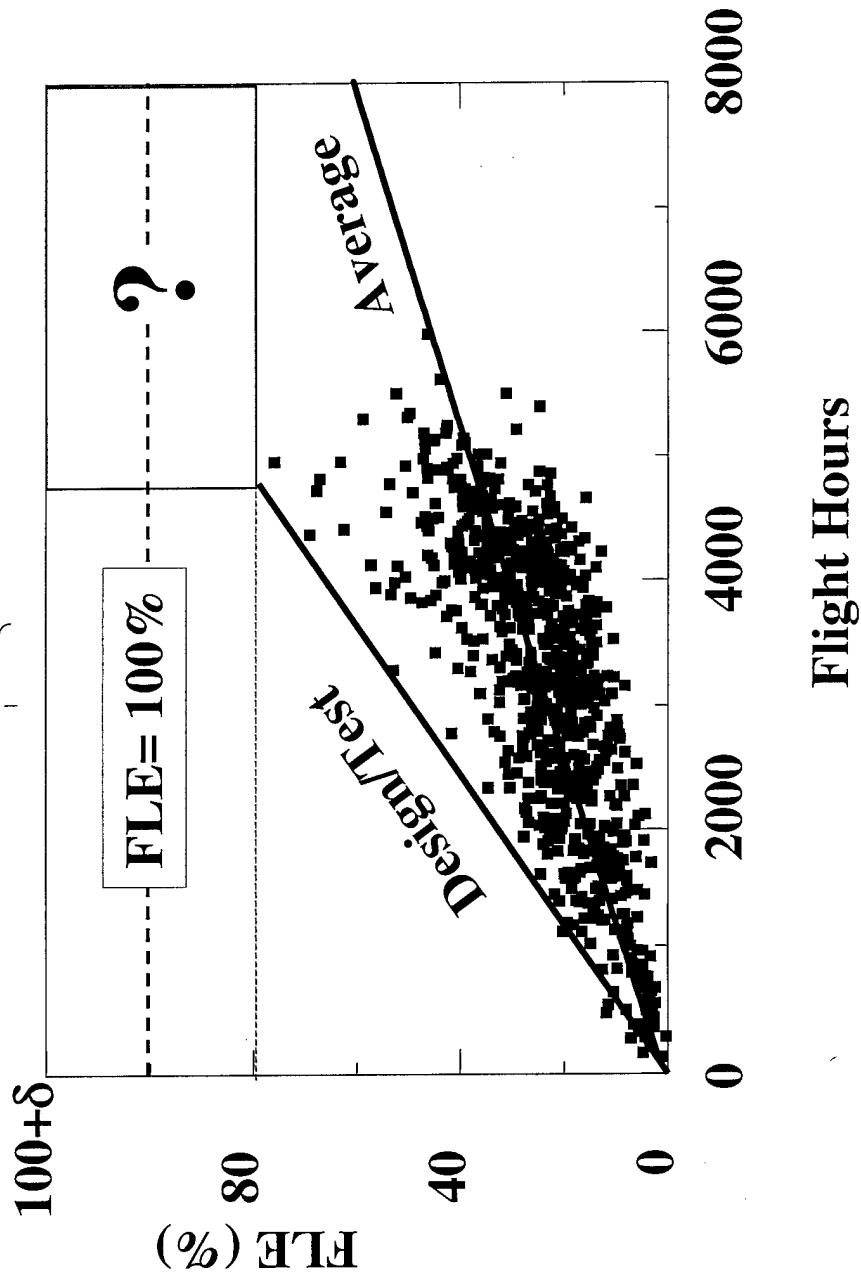

**The early tracking methods had built in conservatism, not so as we become more sophisticated. This raises serious management challenges.**

**Tracking a Single Aircraft**

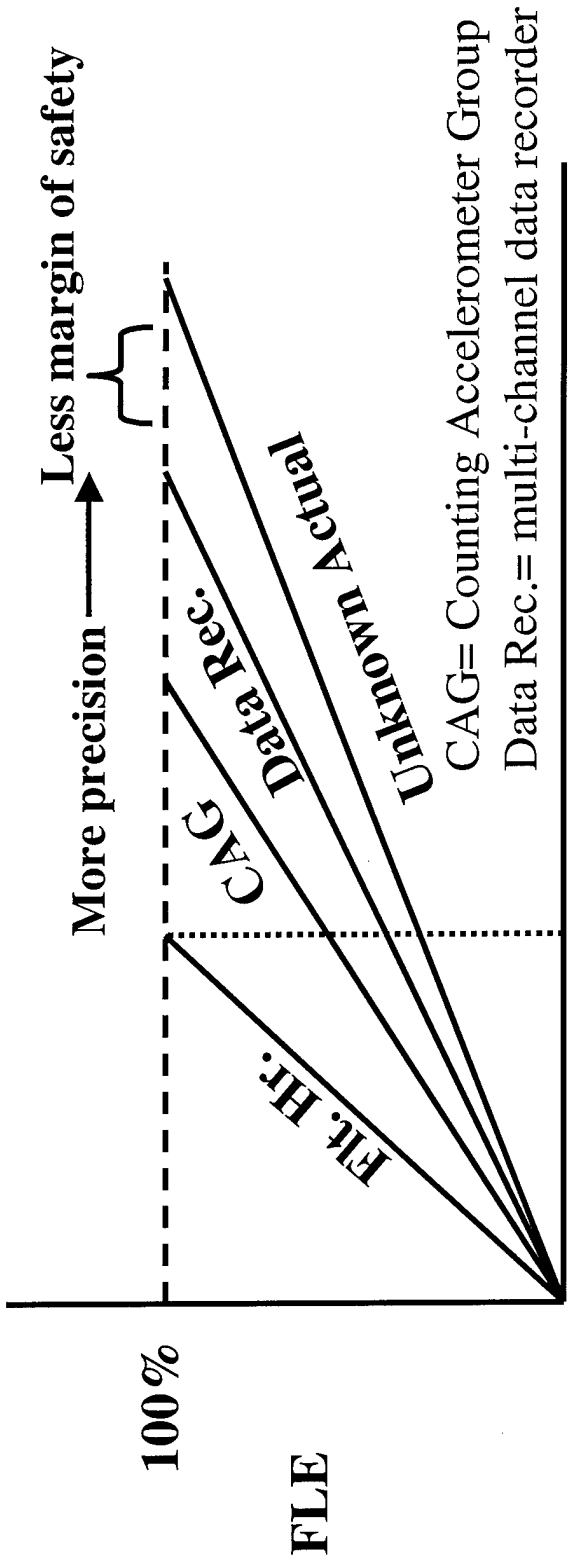

**Actual Flight Hours**

# Flight Recording Methods

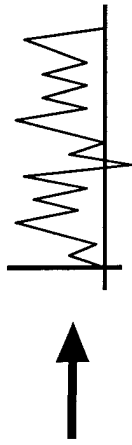
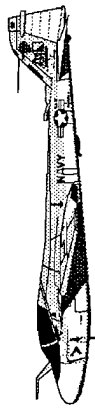

Actual Strain History

Flight Hours

Counting Accelerometer Group (CAG)

Multi-Parameter Data Recorder

Assume:  
Nz  
Weight  
Altitude  
Airspeed

NAVAIR Form 13920/1  
[Nz & Flight Hours ONLY]

Electronic Media  
[Disks, Tapes, etc.]

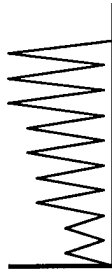
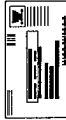

Nz

Assume: Weight  
Altitude  
Airspeed

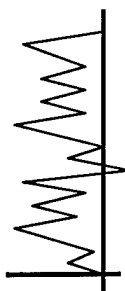

Nz

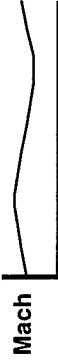

Mach



Alt.



Wt.

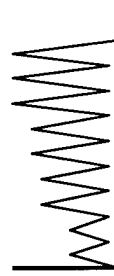

Strain History

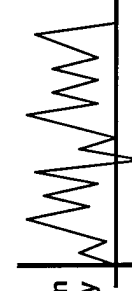

Strain History

3200 HRS

4400 HRS

6600 HRS

AVAILABLE LIFE

**FY1998 AVERAGES:**

- 17.9 YRS - HELICOPTER
- 15.8 YRS - COMBINED
- 14.8 YRS - FIXED WING

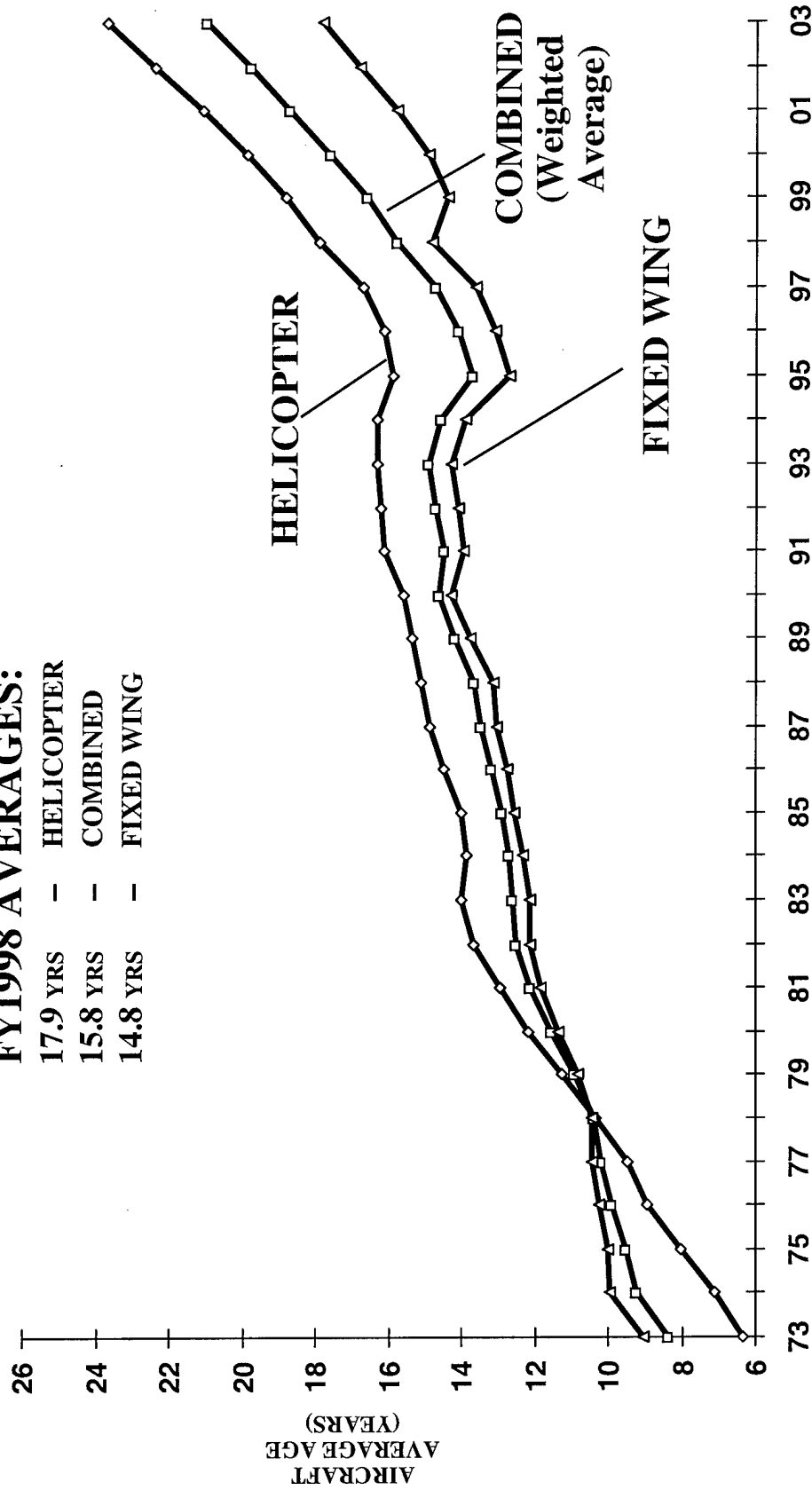

SOURCE: AIR-3.6  
SLIDE UPDATE: 14 JAN 99

FISCAL YEAR

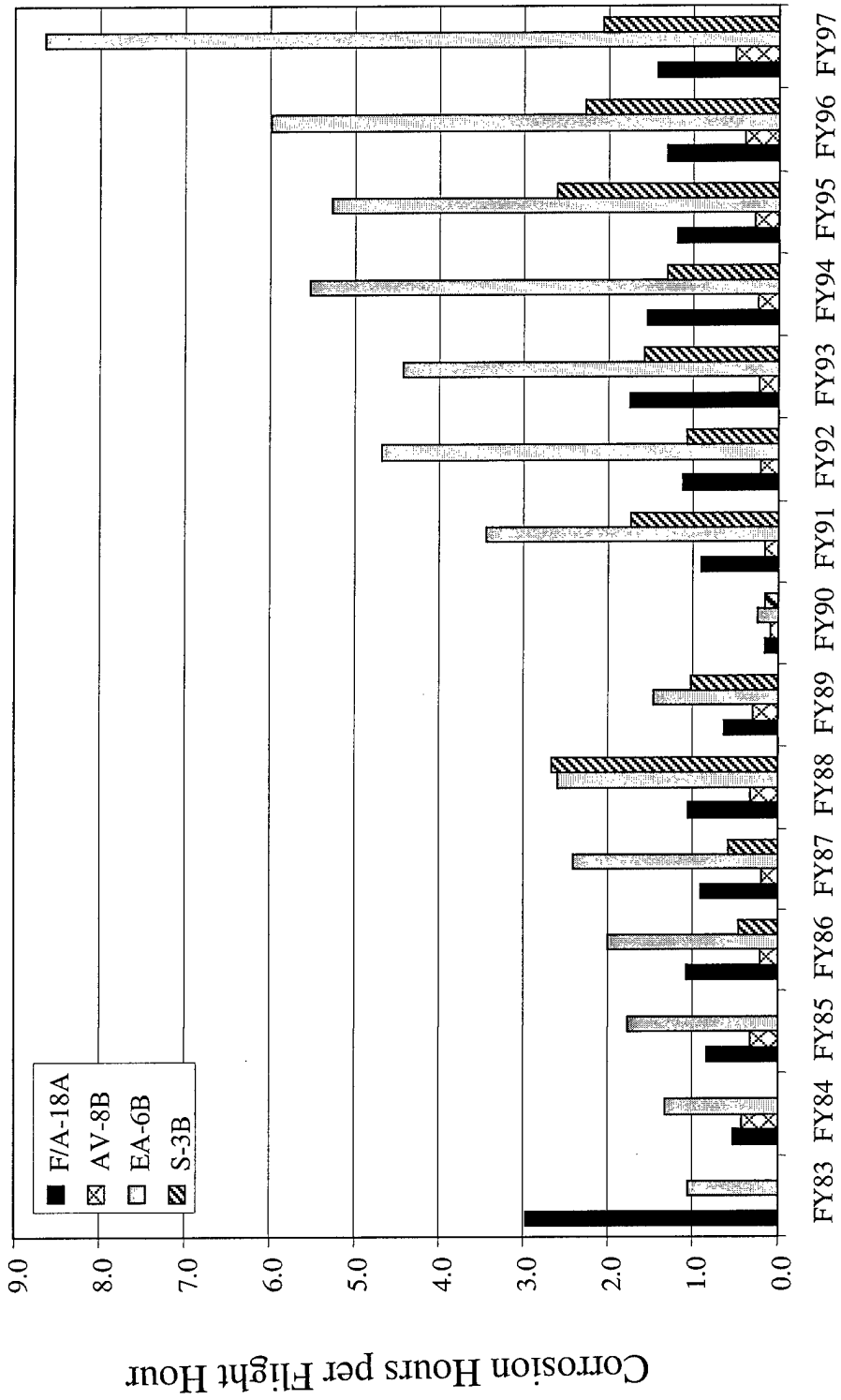

- ◆ Corrosion hours at “O” level increasing through the 1990’s
- ◆ Aircraft in highly corrosive environment dramatically impacted by this trend

# Corrosion Damage Questions: When/How to maintain?

