

DS 000446

**COMBAT RATION NETWORK  
FOR  
TECHNOLOGY IMPLEMENTATION**

**Machine Vision Inspection of Pouch Seal Areas**

**Final Technical Report STP 1007**

**Results and Accomplishments (March 1997 through August 2000)**

**Report No: FTR 108**

**CDRL Sequence: A004**

**March 2001**

**CORANET CONTRACT NO. SPO103-96-D-0016**

Sponsored by:  
DEFENSE LOGISTICS AGENCY  
8725 John J. Kingman Rd.  
Fort Belvoir, VA 22060-6221

Contractor:  
Rutgers, The State University of New Jersey  
THE CENTER FOR ADVANCED FOOD TECHNOLOGY  
Cook College  
N.J. Agricultural Experiment Station  
New Brunswick, New Jersey 08903

Principal Investigators:  
Jeffrey S. Canavan  
Theodore Descovich  
Neal Litman

Dr. John F. Coburn  
Program Director

TEL: 732-445-6130 FAX: 732-445-6145

20010418 045

Read and Write

SCIENTIFIC AND TECHNICAL INFORMATION SYSTEM

1. Acc. Number <b>DS000445</b>	1A. Act. Code <b>AQPO</b>	2. Trans Type <b>M Modify A Record</b>	3. Effort Status <b>C Completed</b>	4. Perf. Meth. <b>C Contract</b>
-----------------------------------	------------------------------	---	--	-------------------------------------

Performance Type 5. <b>R RDT&amp;E Work Unit</b>	6. Date of Summary <b>2001/04/13</b>	7. Prec. Sum Date <b>2000/10/03</b>	8. Start Date <b>1997/05/21</b>	9. End Date <b>2000/08/15</b>	Continuous End <input type="checkbox"/>
---	---	--	------------------------------------	----------------------------------	--

10. Sec. Class. <b>U Unclassified</b>	18. Distribution Code <b>A Distribution Unlimited</b>	19. Distribution Reason <b>PB Public Release</b>
--	--	---

20. Title  
**MACHINE VISION INSPECTION SYSTEM MRE POUCH SEAL AREAS - STP** *1007*

22. Linking Accession Number (Select Up to Two) <b>DS</b>	23. Local Control Number <b>436</b>	24. Search Data <i>STP 1007</i>
--	--	------------------------------------

25. Subject Categories	Description
Code <b>0608</b>	<b>Food, Food Service and Nutrition</b>
<b>1308</b>	<b>Manufacturing and Industrial Engineering and Control of Production Systems</b>

26.1 Mission Area	Description
Code <b>5.1</b>	<b>Logistics</b>

26.2 Function Code	Description
Code <b>7.2</b>	<b>Manufacturing Technology</b>

26.3 Technology Code	Description
Code <b>4.4.2</b>	<b>4.4.2 Computer-Aided Manufacturing, Inspection and Testing Technology</b>

27. Resp. Org. Source <b>432549</b>	27.1 Responsible Organization Name <b>DEFENSE LOGISTICS AGENCY FORT BELVOIR VA</b>
27.2 Responsible Organization Component Name <b>TECHNICAL ENTERPRISE DIVISION</b>	

## 27.4 Responsible Individual

Last Name  
**EGGERS**First Name  
**RUSSELL**MI  
**K**

27.5 Resp. Individ. Off. Sys.

27.6 Resp. Individ. Phone

27.7 Resp. Individ. DSN No.

**J-339****703-767-1417****427-1417**

## 28. Perf. Org. Source

**410970**

## 28.1 Performing Organization Name

**RUTGERS - THE STATE UNIV PISCATAWAY NJ**

## 28.2 Performing Organization Component Name

**CENTER FOR ADVANCED FOOD TECHNOLOGY**

## 28.4 Performing Individual

Last Name  
**COBURN**First Name  
**JOHN**MI  
**F**

28.5 Perf. Individ. Off. Sys.

28.6 Perf. Individ. Phone

28.7 Perf. Individ. DSN No.

**CORANET****908-445-6130**

## 28.8 Associate Investigator Names (Last, First, MI)

**CANAVAN****JEFFERY S.**

## 35. Keyword Text

**RATIONS**  
**THERMOSTABILIZED**  
**PROCESS**  
**QUALITY**  
**CONTROL**  
**CIM ARCHITECTURE**  
**MACHINE VISION**  
**ROBOTICS**  
**DUAL USE**  
**FLEXIBILITY**  
**INTEGRATION**  
**DATA BASE**  
**SHOP FLOOR**

## 36.1 Objective

TO DEVELOP AND DEMONSTRATE A SYSTEM OF ON-LINE INSPECTION FOR DEFECTIVE PRODUCTS USING THE VISION SYSTEM TECHNOLOGY DEVELOPED FOR THE CONTROL OF ROBOTIC PLACEMENT OF MATERIALS. THE SINGLE LANE, SINGLE CAMERA SYSTEM WAS DEMONSTRATED, AND THIS EFFORT IS TO SCALE UP THE EQUIPMENT TO HANDLE ALL OF THE PRODUCTS ON EITHER A TIROMAT OR A MULTIVAC FORM, FILL, SEAL MACHINE.

## 37.1 Approach

BASED ON THE SUCCESS OF THE ONE-LANE PROTOTYPE, PLUS THE NEED FOR FLEXIBILITY BETWEEN TIROMAT AND MULTIVAC MACHINES, THE APPROACH FOR THIS PROTOTYPE IS TO MAKE THE SYSTEM STAND-ALONE, BUT ADAPTABLE TO EITHER HOST MACHINE SO THAT THE HOST MACHINE CAN BE CONTROLLED (STOPPED) IN THE EVENT OF CONTINUING DEFECTS. SINCE MOST OF THE COMBAT RATION PRODUCERS BOUGHT MULTIVAC HFFS MACHINES, THE FOCUS OF THIS EFFORT WAS DIRECTED TO SCALING UP THE DEMONSTRATED SYSTEM TO THE EIGHT (8) CAVITY MULTIVAC. ALLEN-BRADLEY STOPPED MAKING THE KINDS OF PLCs AND OTHER CONTROLLING ELEMENTS, SO A NEW SOURCE HAD TO BE DEVELOPED, CAUSING A SIGNIFICANT SCHEDULE CHANGE

## 38.1 Progress

AS OF MARCH 2001, THE FABRICATED PROTOTYPE HAS BEEN INSTALLED AND TESTED AT THE FMTF, AND IT HAS BEEN SHIPPED FROM THE DEMONSTRATION SITE TO A PRODUCER FACILITY FOR A SIX TO NINE MONTH ON LINE TEST PERIOD. THAT TIME PERIOD HAS NOT YET STARTED, WAITING FOR INTEGRATION INTO A MULTIVAC HFFS THAT IS USED IN ACTUAL PRODUCTION.

30. Primary PE No.	31. 1st Contrib. PE No. <b>0708011S</b>	32. 2nd Contrib PE No.
30A. Primary Proj. No.	31A. 1st Contrib. Proj. No. <b>97002</b>	32A. 2nd Contrib. Proj. No.
30B. Primary Task No.	31B. 1st Contrib. Task No. <b>STP #1007</b>	32B. 2nd Contrib. Task No.

30. Primary Funding Data			31. 1st Cont. Funding Data			32. 2nd Cont. Funding Data			33. Contract
Fiscal Year	Dollars	Work Year	Fiscal Year	Dollars	Work Year	Fiscal Year	Dollars	Work Year	Rollup Indicator

C1	C2	C3	C1	C2	C3	C1	C2	C3	C
1997	20657	1							
D1	D2	D3	D1	D2	D3	D1	D2	D3	D
1996		0							N
E1	E2	E3	E1	E2	E3	E1	E2	E3	E
F1	F2	F3	F1	F2	F3	F1	F2	F3	F
G1	G2	G3	G1	G2	G3	G1	G2	G3	G

39A. Product Set No.	39.1A Prod. Title Class Code	39.2A Product Title
	Unclassified	
39.3A Product ID/Report No	39.4A Product AD No	39.5A Product Indicator

39B. Product Set No.	39.1B Prod. Title Class Code	39.2B Product Title
	Unclassified	
39.3B Product ID/Report No	39.4B Product AD No	39.5B Product Indicator

39C. Product Set No.	39.1C Prod. Title Class Code	39.2C Product Title
	Unclassified	
39.3C Product ID/Report No	39.4C Product AD No	39.5C Product Indicator

39D. Product Set No.	39.1D Prod. Title Class Code	39.2D Product Title
	Unclassified	
39.3D Product ID/Report No	39.4D Product AD No	39.5D Product Indicator

39E. Product Set No.	39.1E Prod. Title Class Code	39.2E Product Title
	Unclassified	
39.3E Product ID/Report No	39.4E Product AD No	39.5E Product Indicator

34. Contract/Grant/Trans. No.	34.1 Contract Effective Date	34.2 Contract Expiration Date	34.3 Contract Face Value	34.4 Contract Cum. to Date
SPO10396D1609	1997/05/21	2000/08/15	234640	165031

40. Dom. Tech Trans.	
41. Study Category	
42. Spec. Study Sub	
44. Prim. Proj. Serial No	
45. Int. Sources Con.	
46. Processing Date	
47. Receipt Date	

49. Thrust Indicator
Technology for Affordability

Focal Point  
Russell Eggers

Author  
Mark Glover

Status Code

# REPORT DOCUMENTATION PAGE

Form Approved  
OMB No. 0704-0188

Public reporting burden for this collection of information is estimated to average 1 hour per response, including the time for reviewing instructions, searching existing data sources, gathering and maintaining the data needed, and completing and reviewing the collection of information. Send comments regarding this burden estimate or any other aspect of this collection of information, including suggestions for reducing this burden, to Washington Headquarters Services, Directorate for Information Operations and Reports, 1215 Jefferson Davis Highway, Suite 1204, Arlington, VA 22202-4302, and to the Office of Management and Budget, Paperwork Reduction Project (0704-0188), Washington, DC 20503.

1. AGENCY USE ONLY (Leave blank)	2. REPORT DATE April 2001	3. REPORT TYPE AND DATES COVERED Final March 1997-August 2000
----------------------------------	------------------------------	--

4. TITLE AND SUBTITLE  Machine Vision Inspection of Pouch Seal Areas Short Term Project - 1007	5. FUNDING NUMBERS  SP0103-96-D-0016 PE - 7811s PR - 88003
---	--

6. AUTHOR(S)  Jeffery S. Canavan	
--	--

7. PERFORMING ORGANIZATION NAME(S) AND ADDRESS(ES)  Rutgers, The State University of New Jersey The Center for Advanced Food Technology Cook College, NJ Agricultural Experiment Station New Brunswick, NJ 08903	8. PERFORMING ORGANIZATION REPORT NUMBER  FTR 108
---	---

9. SPONSORING / MONITORING AGENCY NAME(S) AND ADDRESS(ES)  Defense Logistics Agency 8725 John J. Kingman Road Ft. Belvoir, VA 22060-6221	10. SPONSORING / MONITORING AGENCY REPORT NUMBER
--	--

11. SUPPLEMENTARY NOTES

12a. DISTRIBUTION / AVAILABILITY STATEMENT <b>DISTRIBUTION STATEMENT A</b> Approved for Public Release Distribution Unlimited	12b. DISTRIBUTION CODE
--	------------------------

13. ABSTRACT (Maximum 200 words)

This project developed and demonstrated a multi-camera, full production, machine vision pouch seal area inspection system which was installed on a Multivac horizontal form-fill-seal line located at the CORANET DEMO site. In addition to the inspection system, an automatic reject mechanism was designed and implemented.

The vision system inspects the sealing area of the filled, formed, pouch bottoms for contamination that may cause seal defects. The entire area of contamination is calculated from the camera images. Pouches with seal areas that exceed threshold levels of contamination are rejected via an integrated control system that signals a reject mechanism to pick up and reject the potential defective pouch into a reject bin once the pouch exits the Multivac horizontal form-fill-seal line.

14. SUBJECT TERMS	15. NUMBER OF PAGES 59
	16. PRICE CODE

17. SECURITY CLASSIFICATION OF REPORT Unclassified	18. SECURITY CLASSIFICATION OF THIS PAGE Unclassified	19. SECURITY CLASSIFICATION OF ABSTRACT Unclassified	20. LIMITATION OF ABSTRACT UL
---	--	---	----------------------------------

# Table of Contents

<b>1.0</b>	<b>Introduction</b>
<b>2.0</b>	<b>Background</b>
<b>3.0</b>	<b>Short Term Project Activities</b>
3.1	Phase I Tasks
3.1.1	Review with MRE producers
3.1.2	Preliminary Engineering
3.1.3	Specifications
3.1.4	Economic Analysis
3.1.5	Proposal Preparation/Award
3.2	Phase II – Production Prototype
3.2.1	Production Vision System
3.2.2	Performance Testing
3.2.3	Final Report
<b>4.0</b>	<b>Appendix</b>

## **1.0 Introduction**

STP #1007 began on March 3, 1997 based on a Technical Proposal dated December 19, 1996. The objective of this project was to demonstrate a multi-camera, full production, prototype machine vision pouch seal area inspection system installed on a production Multivac horizontal form-fill-seal line located at the CORANET DEMO site. In addition to the inspection system, an automatic reject mechanism was designed and implemented. This project is a continuation of research carried out under CRAMTD STP#11, "Feasibility of Robotics and Machine Vision in Military Combat Ration Inspection" & CRAMTD STP#63, "Machine Vision Inspection – Pouch Seal Areas".

The vision system inspects the sealing area of the filled, formed, pouch bottoms for contamination that may cause seal defects. The entire area of contamination is calculated from the camera images. An overview of the vision system features is included in Appendix 4.4. Pouches with seal areas that exceed threshold levels of contamination are rejected. An integrated control system signals a reject mechanism to pick up and place rejects into a reject bin.

## **2.0 Background**

Each MRE pouch is visually inspected before and after retorting for surface defects and defective seals. The manual inspection process is labor intensive and not entirely effective at culling out pouches that may leak at a later time due to bad seals. To maintain production throughput, as many as 12 inspectors may be employed. Despite the monumental effort continuously exerted to maintain lot quality control, approximately 2% of lots are still rejected for bad seals.

Horizontal Form Fill and Sealed pouches have four (4) produced seals after filling compared to one (1) produced seal for the preformed vertical sealed pouch. This increases the chance for seal defects due to seal contamination and increases the seal area that needs to be inspected. As the seal area to be inspected increases, the likelihood that one defective pouch with seal contamination will slip past inspection increases as well. The integrated vision system and reject mechanism "culls out" the potentially defective pouches, and thus reduces the chance that these defective pouches end up in the finished product lot.

The Machine Vision System developed under this project will not only have the ability to reject "suspect" pouches, it has the potential to act as a process control tool to warn the operator when seal contamination increases beyond control limits.

The Multiple Unit Leak Detector (MULD), developed under CORANET STP#1005, is available to automatically and non-destructively test each pouch for leaks. This MULD test is however performed several hours or days after the pouch has been filled and sealed, eliminating the ability to perform corrective actions if the number of contaminated seals exceeds control limits.

## **3.0 Short Term Project Activities**

### **3.1 Phase I Tasks**

#### **3.1.1 Review with MRE Producers (Task 4.3.1.1)**

MRE producers were briefed at the CORANET Workshop #6 February 24, 1997 and Workshop #7 April 22, 1997 on the background and status of this project.

An information package was supplied to MRE Producers to support purchasing decisions based on the DSCP Leak Detection Initiative. The information included equipment specifications, cost estimates and other resources.

Phase I of this project concluded with an In-Process Review on May 7, 1997, which was attended by MRE Producers (SOPAKO and Ameriqua), the CORANET Steering Committee and other interested persons. Phase I activities were reviewed and the prototype machine vision inspection system at the Demo site was demonstrated.

Ameriqua Foods agreed to partner with Rutgers on this project giving us the opportunity to test the system in production conditions. However, during the course of this project, a Multivac HFFS machine was installed at the CORANET demo facility and the actual implementation, integration and acceptance testing were performed at the CORANET demo facility.

#### **3.1.2 Preliminary Engineering (Task 4.3.1.2)**

Discussions with Precision Automation and Multivac identified the following equipment integration issues:

- Camera location - loading zone just before top web forming station
- Vision control panel location - near Multivac control panel
- Pouch seal area configurations - tooling drawings provided by Multivac
- Vision Field of View and Resolution - equal to prototype system
- Synchronization with index motion - independent shaft encoder
- Controls for reject mechanism - self contained PLC
- Reject mechanism location - integrated with exit conveyor, dual motion

#### **3.1.3 Specifications (Task 4.3.1.3)**

The Machine Vision system equipment specification was prepared and sent to Precision Automation, the system integrator. This specification can be found in Appendix 4.2. System sub-components were provided by:

- Cognex (Color camera/processor)
- Multivac (HFFS Control)
- Multivac or Precision Automation (Reject Mechanism)
- Precision Automation (Installation and Training)

### **3.1.4 Economic Analysis (Task 4.3.1.4)**

An economic analysis was performed using NCIC (Non-traditional Capital Investment Criteria) and was summarized in TWP#207, "Cost/Benefit Analysis of Machine Vision Pouch Inspection System". This report is included in the Appendix 4.5. The conclusion of this study was that implementation of a machine vision system will generate a significant cost reduction for the MRE producer. It was furthermore concluded that a typical MRE producer should be able to recover the cost of a vision system within a three-year period.

### **3.1.5 Proposal Preparation/Award (Task 4.3.1.5)**

Precision Automation provided several technical/cost proposals for providing a complete system. Several changes that occurred during the project period led to changes in the design and the primary vision processor. The final proposal was dated October 12, 1999. Rutgers University subcontracted this equipment with Precision Automation based on the approval of the CORANET Steering Committee to proceed with Phase II. The Subcontract document can be found in Appendix 4.3

## **3.2 Phase II - Production Prototype**

### **3.2.1 Production Vision System (Task 4.3.2.1)**

The following chronology outlines events of the project.

December 1996	Rutgers Submits Project Proposal
March 1997	Project Awarded
May 1997	Phase I In-Process Review
October 1997	Delay: No Operational Multivac Decision to proceed with Tiromat platform
July 1998	Reverted to Multivac Sealer from Tiromat
December 1998	Qualified Cognex to replace Allen-Bradley Vision Platform Multivac Operational at Demo Site
March 1999	Interim Technical Report
May 1999	TWP #207 "Cost/Benefit Analysis of Machine Vision Pouch Inspection System"
October 1999	Initiated Subcontract process
February 2000	Subcontract issued
March 2000	Functional Specification Approved
April 2000	Engineering Release
June 2000	Manufacture Completed
July 21-Aug. 9, 2000	Installation and Start-up Completed
August 2000	Plant Evaluation Completed
August 15, 2000	Project Ends

### **3.2.2 Performance Testing (Task 4.3.2.2)**

The system installation and acceptance was completed at the Demo Site on August 9, 2000. Due to time constraints and dwindling film inventory, an extended test in a 'Production Mode' was not possible. During the system acceptance, however, several issues were revealed that made it clear that the implementation still required some fine-tuning.

The acceptance test consisted of running 2000+ pouches at 120 pouches per minutes through the vision system. During the run, random indexes were contaminated with water droplets, the least detectable contaminate. The vision screen monitored the seal area and the contaminated pouches were rejected by the system. Detecting contamination was 100% effective in the areas inspected. Of the 32 seal areas representing an index, the best results occurred when inspecting the inner most 28 areas. The 4 areas adjacent to the outer edges of the film web could not be reliably inspected because the film was not flat in this area. The edge of the film exhibited a creasing effect from the punched vent holes that are created to equalize pressure during the vacuum/sealing cycle. Additionally, the bottom web would not maintain consistent lateral positioning to optimize seal areas flatness for the remaining 28 areas. The result of the film wandering would be the appearance of non-uniformity when none existed. More than 10% of non-contaminated pouches were falsely rejected because of the flatness problem.

Producers typically resolve the film wandering issue in production within the first hours of extended production. After running the Multivac for several hours, the issue is likely to be minimal. However, the vent holes would still require a manual pressing or rolling if the outer edges are to be inspected (see also appendix 4.1).

Once film flatness is controllable, seal area contamination characteristics need to be established. After alarm and rejection specifications are reviewed and dialed in, different products will require minimal, if any, tuning of the vision tools to maximize effectiveness and reduce false rejects.

Extended production tests with a wide variety of products were not performed under this contract due to the fact that the Multivac equipment was shipped from the facility to Ameriquel Foods. However, a continuing STP is proposed that would install the vision system at one of the producers facilities on a Multivac HFFS. In this project, the CAFT, FMTF staff at Rutgers University would monitor and fine-tune the performance of the system on a variety of products for several months.

### **3.2.3 Final Report (Task 4.3.2.3)**

Preparation of this report is the final task and deliverable for STP#1007.

## **4.0 Appendix**

- 4.1 Film Flatness Memo**
- 4.2 Specifications for Machine Vision System**
- 4.3 Vendor Proposal**
- 4.4 Cognex Checkpoint Slides**
- 4.5 Economic Analysis, TWP#207**

## **Appendix 4.1**

### **Film Flatness Memo**

Memorandum

Feb. 9, 2000

RE: Multivac Seal Area Surface for Machine Vision Inspection

Xyntek, acting as a subcontractor to Precision Automation has carefully reviewed the Multivac machine vision inspection system application and requirements. In order to meet the resolution requirements, Xyntek has determined that the web surface must be level within +/- 3mm.

A survey of web flatness was then made. Results of the inspection were all points within 3mm of the highest point (+/- 1.5mm).

Since there are uncertainties with respect to web flatness during production; support rail positioning, film tension, weight of product in pouch; Rutgers should accept this small risk and be prepared to make some modifications to the Multivac if the need arises. Solutions might include web support rails, film guides and forming system adjustments.

**(Neal Litman)**

## **Appendix 4.2**

### **Specifications for Machine Vision System**

**Specification for Vision Inspection System  
for Multivac H-F-F-S Packaging Line**

**1.0 Application**

Inspect seal areas of packages on a Multivac horizontal-form-fill seal production line for food contamination. The vision system procured under this specification is a modified version of the prototype system previously constructed for Rutgers CAFT FMTF pilot plant, under "Specification for Vision Inspection System for H-F-F-S Packaging Line," dated March 13, 1996.

**2.0 Production Requirements**

2.1 Production Line: Multivac 530 horizontal form-fill-seal packaging line forming MRE pouches in a 4 lane by 2 row index. The film surface is polypropylene over aluminum foil. Multivac total cycle time is 4.0 seconds (15 indexes per minute), having a dwell of approximately 3.0 seconds. The film advance is by servo motor drive programmable for acceleration/deceleration. The vision inspection system will be at the last complete package index of the filling zone and occupy the smallest possible area.

2.2 Area to inspect: The vision inspection system will inspect the seal areas of each pouch including adjacent web areas (between pouches and at the transport chain clips). The system will be required to inspect all eight pouches of per index. Note: due to forming, the seal area is not perfectly flat or smooth.

2.3 Defects/Objects to be identified: Water droplets, gravy droplets or smears, solid pieces (meat or vegetables). Defects are 1.5mm in diameter or larger.

**3.0 Performance Requirements**

Accuracy/Reliability: The system will identify 75% of defects from 1.5 to 3.0mm in diameter and 98% of defects greater than 3.0mm in diameter. The vision system will reject less than 0.25% "good" pouches.

**4.0 Integration**

4.1 Integration with Multivac: The controls will be integrated as needed. Operation of the Multivac will not be affected by the vision

system. Vision system trigger source can be provided by the Multivac controller relay, however the servo motor encoder may not be used.

4.1 Package Reject: defective pouches will be automatically removed at the Multivac discharge. Pouches may be dropped into a tote bucket.

4.2 Data Collection: The vision system will collect and display results of each image and overall production statistics (number of packages inspected, rejected, location of defects).

4.3 Physical Requirements: The vision system and rejecter will be operated in a washdown environment (any components that are easily moved from line need only be splash proof), compliance with USDA is required (stainless steel or anodized aluminum above the food line), operating power will be 120V.

## **5.0 Operator Interface**

The vision system will be operated at a movable control panel. Programming, control and status display will be at this station. The system will be programmed for automatic startup, the display will be set for the production statistics screen. Vision system operating status and faults will also be available to line operators. The statistics summary, and counters will be reset in a password protected mode.

## **6.0 Project Scope**

6.1 Vision system hardware and software: Cognex Checkpoint 900C vision processor(s), cameras, lens, cables and wiring, monitor, input devise.

6.2 Lighting: Reflectors, baffles, hood, light, and fiberoptic cables will be provided as needed. Ambient room light will not affect the vision system.

6.3 Support: Frame to mount camera and lighting to Multivac will be supplied. This fixture should be removable to facilitate production line cleaning. Mounting features should include guides for camera alignment to the Multivac.

6.4 Enclosure: Stainless steel cabinets for processor (on wheels) and camera will be provided as needed.

6.5 Reject Mechanism: A conveyor type mechanism that removes pouches marked by the vision system. The reject mechanism will be located at the Multivac discharge. The reject mechanism must be capable of withstanding washdown.

6.5 Programming: Vision system calibration and application specific software.

6.6 Installation: Delivery of equipment to Rutgers U. FMTF, wiring to PLC and any other necessary devices, assembly of hardware components, calibration and acceptance test.

6.7 Acceptance Test: A test will be run after installation has been completed to demonstrate performance requirements have been met. Preliminary acceptance test will be run at the vendors facility.

6.8 Training: Instruction for use and maintaining equipment will be given to plant personnel at the completion of a successful Acceptance Test.

6.9 Documentation/Manuals: Drawings, software and manuals are required.

## **Appendix 4.3**

### **Vendor Subcontract**

THE STATE UNIVERSITY OF NEW JERSEY

**RUTGERS**

Office of Research and Sponsored Programs  
Administrative Services Building • Annex II • Busch Campus  
Rutgers, The State University of New Jersey  
58 Bevier Road • Piscataway • New Jersey 08854-8010  
Email: sponpgms@orsp.rutgers.edu • Web: <http://info.rutgers.edu/orsp>  
Tel: 732/445-2880 • FAX: 732/445-3257

**SUBCONTRACT AGREEMENT NO. 1079  
IN AGREEMENT WITH  
RUTGERS, THE STATE UNIVERSITY  
and  
PRECISION AUTOMATION CO., INC.**

**Address:** Box 18  
Haddonfield, NJ 08033

**For:** Performance of certain work and services in connection with Rutgers  
account number: 4-25248  
award number: SPO103-96-D-0016-0009, CORONET STP #1007

**Project Sponsor:** Defense Logistics Agency

**Project Title:** Design/build OF A Machine Vision Inspection System (Multivac)

**Rutgers Project Director/  
Principal Investigator:** Neil Litman

**Department:** Center for Advanced Food Technology

**Type of Contract:** Cost Reimbursement

**Period of Performance:** December 15, 1999 to March 31, 2000

**Maximum Allowable Price:** \$150,000

**Issued by:** Rutgers, The State University  
Office of Research and Sponsored Programs  
58 Bevier Road  
Piscataway, NJ 08854-8010

**Invoice to:** Rutgers, The State University  
CAFT/Food Manufacturing Technology Facility  
120 New England Avenue  
Piscataway, NJ 08854  
Attn: Dr. John Coburn

## TABLE OF CONTENTS

<u>ITEM</u>	<u>PAGE</u>
PREAMBLE	3
TERMS AND CONDITIONS	
ARTICLE 1    SCOPE OF WORK	3
ARTICLE 2    KEY PERSONNEL	3
ARTICLE 3    PERIOD OF PERFORMANCE	3
ARTICLE 4    COMPENSATION AND METHOD OF PAYMENT	4
ARTICLE 5    REPORTING REQUIREMENTS	4
ARTICLE 6    AUDIT	4
ARTICLE 7    RIGHTS IN DATA AND COPYRIGHTS	5
ARTICLE 8    INTELLECTUAL PROPERTY	5
ARTICLE 9    TERMINATION	5
ARTICLE 10   PROVISIONS OF PRIME AGREEMENT	6
ARTICLE 11   PUBLICITY	6
ARTICLE 12   DISPUTES	6
ARTICLE 13   DEBARMENT AND SUSPENSION	6
ARTICLE 14   EQUAL OPPORTUNITY/AFFIRMATIVE ACTION	7
ARTICLE 15   INDEMNIFICATION	7
ARTICLE 16   ASSIGNMENT	7
ARTICLE 17   ENTIRE AGREEMENT	7
ARTICLE 18   SITUS	7
EXHIBIT A    STATEMENT OF WORK/TERMS & CONDITIONS OF SALE	
EXHIBIT B    PERFORMANCE SPECIFICATION	
EXHIBIT C    CONTRACT CLAUSES FROM PRIME AGREEMENT	
EXHIBIT D    CERTIFICATIONS AND REPRESENTATIONS	

This Agreement is entered into by and between Rutgers, the State University of New Jersey, with principal offices in New Brunswick, New Jersey (hereinafter called "RUTGERS"), and Precision Automation Co., Inc. (hereinafter called "SUBCONTRACTOR"), and constituting a subcontract under Contract No. SPO103-96-D-0016/0009, CORONET STP #1007 from the Defense Logistics Agency issued to Rutgers, the State University.

**WITNESSETH THAT:**

SUBCONTRACTOR agrees to perform the work and services in accordance with the terms and conditions set forth in this Agreement for the consideration stated herein. Therefore, it is agreed as follows:

**ARTICLE 1. SCOPE OF WORK**

- a) SUBCONTRACTOR shall provide the necessary personnel, equipment, facilities, and supplies to perform the work described in the Statement of Work, which is attached hereto as Exhibit A.
- b) Unless specifically stated elsewhere in this Agreement, the quality of all services rendered hereunder shall conform to the highest standards in the relevant profession, trade, or field of endeavor. All services shall be rendered by or supervised directly by individuals fully qualified in the relevant professions, trade, or field, and holding any licenses required by law.

**ARTICLE 2. KEY PERSONNEL**

- a) SUBCONTRACTOR shall designate Jack Tarman as its Project Director/Principal Investigator. Mr. Tarman shall not be removed or replaced without the prior written approval of RUTGERS.
- b) RUTGERS hereby designates Neil Litman as its Project Director/Principal Investigator for this work.

**ARTICLE 3. PERIOD OF PERFORMANCE**

- a) The period of performance under this Agreement shall begin on December 15, 1999 and shall end on March 31, 2000, unless extended by mutual written agreement, or terminated in accordance with the terms of this Agreement.
- b) The schedule is as follows:

Order placement by 12/15/99  
Functional Specification and approval - 4 weeks after order  
Engineering release to manufacturing - 4 weeks after functional spec. approval  
Manufacturing complete & factory test - 5 - weeks after engineering release  
Installation and start up - 2 weeks after factory test

#### **ARTICLE 4. COMPENSATION AND METHOD OF PAYMENT**

a) The total amount available to SUBCONTRACTOR for performance hereunder is \$150,000 as specified in the budget, which shall not be exceeded unless changed by written amendment to this Agreement.

b) SUBCONTRACTOR shall be paid according to the following schedule:

- 30% of total upon order placement
- 30% of total functional specification approval
- 30% of total upon factory test
- 10% of total upon installation and start up

Travel and living expenses for project management/engineering/programming are not included and will be billed as actual expenses with net 30 payment terms.

Invoices shall be submitted to the CAFT/Food Manufacturing Technology Facility, referencing account no. 4-25248.

#### **ARTICLE 5. REPORTING REQUIREMENTS**

a) SUBCONTRACTOR shall submit such technical reports to the RUTGERS Project Director/Principal Investigator as required by RUTGERS to meet the technical report requirements of the prime agreement. Each report shall be submitted sufficiently in advance of the report deadline to allow review and comment by the RUTGERS Project Director/Principal Investigator prior to transmittal to the funding agency.

b) All required technical/financial reports and project-related records will be maintained and made available by SUBCONTRACTOR in accordance with FAR 52.215.1, "Examination of Records by Controller General," for a period of not less than three (3) years following the submission and acceptance of the final reports.

#### **ARTICLE 6. AUDIT**

c) SUBCONTRACTOR shall maintain appropriate accounting records sufficient to properly document costs claimed as incurred in the performance of this Agreement, and shall make such records available, upon request, to authorized RUTGERS or sponsor personnel for audit purposes pursuant to FAR 52.215.2, "Audit Negotiation." Said records shall be retained and kept available by SUBCONTRACTOR for a period of not less than four (4) years after final payment by the University, or if notified of an audit and notification by RUTGERS of resolution of any exceptions resulting therefrom, whichever occurs first.

b) If any amount paid hereunder by RUTGERS is subsequently disapproved or disallowed by the sponsor or another agency, SUBCONTRACTOR shall upon demand and without litigation, promptly repay RUTGERS said disapproved or disallowed amount.

## **ARTICLE 7. RIGHTS IN DATA AND COPYRIGHTS**

- a) Unless otherwise specified herein, any data developed by SUBCONTRACTOR in the performance of this Agreement shall be and remain the sole property of SUBCONTRACTOR.
- b) SUBCONTRACTOR is free to copyright material developed under or in connection with this Agreement, and shall give notice to RUTGERS of any material so copyrighted.
- c) RUTGERS and sponsor shall have a royalty-free, nonexclusive, world-wide and irrevocable right to reproduce, publish, or otherwise use, and to authorize others to use, such data and material.

## **ARTICLE 8. INTELLECTUAL PROPERTY**

- a) "Intellectual Property" shall mean patents, patent applications, and know-how
- b) Unless otherwise provided herein, all Intellectual Property relating to inventions conceived and reduced to practice solely by SUBCONTRACTOR in the performance of this Agreement shall be and remain the sole property of SUBCONTRACTOR. Intellectual Property relating to inventions conceived and reduced to practice solely by RUTGERS in the performance of this Agreement shall be and remain the sole property of RUTGERS. Intellectual Property relating to inventions conceived and reduced to practice jointly by RUTGERS and SUBCONTRACTOR in the performance of this Agreement shall be jointly owned.
- c) Unless otherwise provided herein, RUTGERS shall have a royalty-free, nonexclusive, worldwide, and irrevocable right to use SUBCONTRACTOR'S Intellectual Property both for research and educational purposes, and to satisfy the requirements of the Sponsor.
- d) In the event that commercially useful developments are made from SUBCONTRACTOR'S rights to Intellectual Property originating under or derived from this Agreement, SUBCONTRACTOR, in consideration for RUTGERS funding hereunder, shall provide RUTGERS reasonable compensation which shall be mutually determined by the parties at the time these developments are reasonably identified.
- e) Certain patent and invention rights and other rights of RUTGERS, SUBCONTRACTOR, and the U.S. Government relating to inventions hereunder are specified in and governed by 48CFR227 and 252, as amended, and 37CFR401.14 of July 1, 1987, which provisions are incorporated herein by reference.

## **ARTICLE 9. TERMINATION**

- a) RUTGERS may terminate this Agreement with or without cause at any time by giving thirty (30) days written notice when it is determined that termination is in RUTGERS' best interest. SUBCONTRACTOR shall, upon receipt of notice of termination from

RUTGERS, refrain from incurring any further costs under this Agreement and shall use its best efforts to cancel any commitments made by it prior to receipt of such notice. Such termination shall, however, not affect any commitments which, in the judgement of RUTGERS, have properly become legally binding prior to the effective date of termination and which could not reasonably have been rescinded by SUBCONTRACTOR. Any prepaid but unearned funds shall be returned to RUTGERS.

- b) It is understood and agreed, however, that in the event that SUBCONTRACTOR is in default upon any of its obligations hereunder at the time of termination, RUTGERS reserves the right to pursue, in addition to termination, any other rights or remedies which RUTGERS may have against SUBCONTRACTOR, and RUTGERS may withhold any payments to SUBCONTRACTOR for the purpose of set-off until such time as the exact amount of damages may be determined.

#### **ARTICLE 10. PROVISIONS OF PRIME AGREEMENT**

All applicable provisions contained in the prime agreement shall be binding upon the SUBCONTRACTOR as listed in Exhibit C. A complete copy of the prime agreement is available for review at the SUBCONTRACTOR'S request.

#### **ARTICLE 11. PUBLICITY**

No publicity matter having or containing any reference to RUTGERS or in which the name of RUTGERS is mentioned shall be made use of by SUBCONTRACTOR until written approval has been obtained from RUTGERS.

#### **ARTICLE 12. DISPUTES**

Any disagreements arising out of this Agreement, or from a breach thereof, shall be submitted to arbitration, and the judgement upon the award rendered by the arbitrators may be entered in any court having jurisdiction thereof. The arbitration shall be held under the procedures and rules of the American Arbitration Association. Any arbitration shall be held in Newark, New Jersey, unless mutually agreed otherwise.

#### **ARTICLE 13. DEBARMENT AND SUSPENSION**

- a) In accepting this Agreement, SUBCONTRACTOR certifies that neither it nor its principals are presently debarred, suspended, proposed for debarment, declared ineligible, or voluntarily excluded from participation in the transaction by any Federal department or agency. Any change in the debarred or suspended status of SUBCONTRACTOR during the life of this Agreement must be reported immediately to RUTGERS. SUBCONTRACTOR agrees to incorporate the Debarment and Suspension Certification into any subcontract that they may enter into as a part of this Agreement.
- b) If SUBCONTRACTOR is unable to certify to any of the statements in this certification, SUBCONTRACTOR shall attach an explanation to this Agreement.

- c) This certification is required by the regulations implementing Executive Order 12549, Debarment and Suspension, 34 CFR Part 85, Section 85.510, Participant's responsibilities. The regulations were published as Part VII of the May 26, 1988 Federal Register, pages 19160-19211. Copies of the regulations may be obtained by contacting the authorizing official of RUTGERS.

#### **ARTICLE 14. EQUAL OPPORTUNITY/AFFIRMATIVE ACTION**

- a) This Agreement is subject to the requirements of Executive Order 11246 and 11375 and the rules and regulations of the Secretary of Labor (41 CFR Chapter 60) in promoting Equal Employment Opportunities.
- b) SUBCONTRACTOR hereby certifies that it does not and will not maintain any facilities it provides for its employees in a segregated manner, or permit its employees to perform their services at any location under its control, where segregated facilities are maintained; and it will obtain a similar certification prior to award of any non-exempt subcontract approved hereunder.

#### **ARTICLE 15. INDEMNIFICATION**

All persons rendering services covered by this Agreement on behalf of SUBCONTRACTOR, including faculty, staff, students, or other agents, shall be considered to be employees of SUBCONTRACTOR for the purpose of any state workers' compensation laws or federal workers' compensation statutes. SUBCONTRACTOR hereby agrees to indemnify RUTGERS against all claims or awards under such workers' compensation laws arising out of this Agreement.

#### **ARTICLE 16. ASSIGNMENT**

This Agreement shall not be assigned in whole or in part without the prior written consent of RUTGERS.

#### **ARTICLE 17. ENTIRE AGREEMENT**

This Agreement constitutes the entire agreement between RUTGERS and SUBCONTRACTOR with respect to the subject matter hereof, and supersedes and replaces any other arrangements, oral or written, between the parties hereto pertaining to this subcontract. No waiver, modification, or amendment of any of the terms and conditions hereof shall be effective unless set forth in writing duly signed by RUTGERS and SUBCONTRACTOR.

#### **ARTICLE 18. SITUS**

Regardless of place of physical execution or performance, this Agreement shall be construed according to the laws of, and deemed to have been executed in, the state of New Jersey.

IN WITNESS WHEREOF, the respective parties have executed this Agreement on the dates indicated below.

PRECISION AUTOMATION CO., INC.

RUTGERS, THE STATE UNIVERSITY

By: \_\_\_\_\_

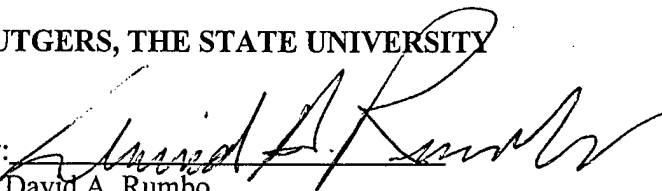
By:   
David A. Rumbo  
Acting Director  
Office of Research & Sponsored Programs

Date: \_\_\_\_\_

Date: 11/1/00

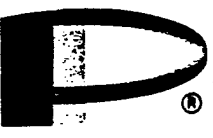

**PRECISION AUTOMATION CO., INC.**

BOX 18  
HADDONFIELD, NJ 08033  
609-428-7400  
FAX 609-428-1270

October 12, 1999

98-3034r02

Rutgers, The State University of New Jersey  
Food Manufacturing Technology Facility  
120 New England Ave.  
Piscataway, NJ 08854

Attn: Neal Litman, FAX (732) 445-6145

The following is in response to a request for an updated quotation for the design & manufacturing of the **Multivac Vision Inspection System with Reject Mechanism** project.

This quote has been prepared after a careful review of all the project requirements. An approach has been developed utilizing extensive machine and control system integration experience. As a result, we believe that this approach will lead to a successful project which will be on target, on time and on budget.

Thank you for this opportunity to provide this quotation. We are looking forward to meeting with you to review this quote in detail and providing our services on this and future projects.

Very truly yours,

Jack Tarman

Copy To:

- 1. File
- 2. JET File

FAX copy to:

- 1. (732) 445-6145

**PRECISION AUTOMATION CO., INC.**  
**PROPOSAL NO. 98-3034 Rev. 2**

Proposal for

**RUTGERS, THE STATE UNIVERSITY OF NEW JERSEY**  
**FOOD MANUFACTURING TECHNOLOGY FACILITY**

**Multivac Vision Inspection System**

**Design/Build**  
**Equipment, Controls & Installation**

**TABLE OF CONTENTS**

**BASIS OF PROPOSAL:** ..... 2

CUSTOMER REQUIREMENTS: ..... 2

APPROACH: ..... 3

**PROPOSED SCOPE:** ..... 4

ENGINEERING & DESIGN SERVICES: ..... 4

CONTROL PANEL(S) & CONTROL EQUIPMENT: ..... 4

CAMERA & LIGHTING ASSY: ..... 5

REJECT MECHANISM: ..... 5

FIELD SERVICE ALLOWANCES @ RUTGERS FOR INSTALLATION, START-UP AND ACCEPTANCE TESTING: .. 5

**COMMERCIAL:** ..... 6

PRICING: ..... 6

PAYMENT TERMS: ..... 6

SCHEDULE: ..... 6

CUSTOMER SERVICE SUPPORT: ..... 7

GENERAL TERMS: ..... 7

**APPENDIX I - CONTRACT TERMS:** ..... 9

## Basis of Proposal:

The following information has either been provided to Precision Automation or is the result of Precision Automation's development of an approach to provide an automation solution within the declared needs and constraints. All of the following information forms the basis of this proposal:

### Customer Requirements:

#### I. General Requirements:

- A. This system is to be a modified version of the prototype system previously furnished by Precision Automation for Rutgers CAFT FMTF pilot plant.
- B. A Plan only is to be developed to implement the vision system on the Multivac 530.
  1. Multivac 530 forms MRE pouches in a 4 lane by 2 row index (8 pouches per index) in a 4.0 sec cycle time (2.5 sec dwell).
  2. The proposed unit is to inspect the seal area of all eight pouches per index.
  3. Defects are the same as defined for the prototype system previously furnished by Precision Automation and this system has been tested and proven to meet and exceed the minimum performance requirements.
- C. The vision system will not be unitized. The camera & lighting assembly will be mounted and secured to the machine and the operator interface will be located in a separate movable control console.
- D. The project scope includes:
  1. Vision System Equipment - Processors, cameras, lens, monitor, cables, assembly, wiring, etc.
  2. Lighting - Light source, hoods, baffles, reflectors.
  3. Frame - for mounting camera, lighting etc. to the Multivac.
  4. Enclosure for processor, controls (on wheels) Processor (PC) may be desktop.
  5. Reject Mechanism - 4x2 pouch configuration.
  6. Programming -
    - a) Vision system configuration & application specific.
    - b) PLC application programming for reject mechanism & trigger for inspection system.
  7. Installation - Included as a defined allowance. Installation is to be provided on the Multivac machine at the Rutgers facility, Piscataway, NJ.
  8. Acceptance Test - Included as a defined allowance. Test is to be provided on the Multivac machine at the Rutgers facility, Piscataway, NJ.
  9. Documentation - Drawings, S/W, and manuals (PAC Std).

October 12, 1999  
Rutgers, The State University of New Jersey

Proposal No. 98-3034R02  
Multivac Vision Inspection System

- II. Specification for Vision Inspection System for Multivac H-F-F-S Packaging Line dated 1/27/99.
- III. Drawings:
  - A. Multivac machine assembly drawing (plan & elevation views).
  - B. Multivac MRE "Primary" pouch (2 x 4).
- IV. Meeting @ Precision Automation on 4/24/97.
  - A. Specification Review.
  - B. Application review.
  - C. Determine needs for additional information.
- V. Site Visit to Rutgers on 4/28/97.
  - A. Present system meets & exceeds performance requirements utilizing the prototype vision systems field of view (approx. 8.5" x 11.5").
- VI. Revisions as discussed during our meeting on 10/22/97 (Rev. 2) and updated at our meeting on 12/23/98.
  - A. Vision inspection design plans are to be adaptable for both 2x3 and 4x2 pouch configurations.
  - B. Reject mechanism design plan is to be adaptable for use with 2x3 and 4x2 pouch configurations.
  - C. Lighting system on prototype system is to be evaluated (uniformity & ambient light) to determine if changes are required.
  - D. Color vision modules to include a math co-processor.
- VII. Review of requirements at Rutgers with Cognex representatives on 2/10/99.
- VIII. Review of Cognex set up and evaluation at Cognex on 2/15/99.
  - A. Color camera with Cognex checkpoint 900C vision H/W and S/W.
- IX. Evaluation of Cognex approaches and alternatives at Rutgers on 2/18/99.
  - A. 2 Processors - 2 Cameras on 4 position servo driven platform.
  - B. 2 Processors - 2 Cameras on 2 position indexing platform.
  - C. 1 Processor - 4 Cameras on stationary platform.

**Approach:**

The basic vision system design will be reused since the prototype system has proven performance that exceeds the minimum performance specifications.

- I. The vision system will have the same resolution for defect detection since the inspections will be made using the same field of view as the prototype system. The Cognex inspection tools (software) provide an enhanced analysis for defects.
- II. In order to inspect all eight pouches (4 lanes x 2 rows) a four camera system on a stationary platform will be utilized.
- III. Data collection: requirements for the collection and display of results (e.g. location of defects) needs to be clarified but will be limited to the capability of the vision system.
- IV. System will be initially installed on a Multipac machine at Rutgers, NJ. Camera and lighting frame will be supplied with an 8ft. cable for connection to the control console.
- V. The reject mechanism will consist of a four lane conveyor with guides and four gravity slide reject gates.

October 12, 1999  
 Rutgers, The State University of New Jersey

Proposal No. 98-3034R02  
 Multivac Vision Inspection System

**Proposed Scope:**

The following tasks and deliverables for this project are expected to be provided by Precision Automation's project execution process:

**Engineering & Design Services:**

Qn	Description	Mfg	Catalog Number
1	Kick-off Mtg		
1	Functional Spec. Consist of: Operator Screens Operator Prompts & Responses Vision System/PLC Interactions		(For Approval)
1	Vision Application Software		Cognex Checkpoint 900C platform
1	PLC Application Software		AB PLC 500 platform
1	Design & Provide Uniform Lighting & Camera Mtg		
1	Electrical Elementary Wiring Diagram		
1	Panel Layout Drawing		
1	Preliminary Accept. Test (FAT)		

**Control Panel(s) & Control Equipment:**

Qn	Description	Mfg	Catalog Number
1	Control Panel (Portable)	Hoffman	
1	PLC System		
1	Item of Pushbuttons & Pilot Lts		
1	PC - Computer		
1	Vision Processor	Cognex	
1	Multiplexer-4 Camera to 1 Proc.	FSR	
1	Item of Terminal Blocks		
1	Item of Cables		

October 12, 1999  
 Rutgers, The State University of New Jersey

Proposal No. 98-3034R02  
 Multivac Vision Inspection System

**Camera & Lighting Assy:**

Qn	Description	Mfg	Catalog Number
	1 Framework for Multivac Mounting		
	4 Color Camera Kits		
	4 6mm Lens w/Polarized Analyzer		
	1 Set of HS Florescent Lights		
	1 Set of ambient light shields		

**Reject Mechanism:**

Qn	Description	Mfg	Catalog Number
	1 Conveyor System w/guides		
	4 Photo Eye Sensors		
	4 Slide Gate Cylinder Actuators		
	1 General Assembly		
	1 Test & Debug		

**Field Service Allowances @ Rutgers for Installation, Start-Up, Acceptance Testing and Training:**

Qn	Description	Mfg	Catalog Number
	20 Days (2 per./10 days)-		Precision Automation
	10 Days (1 per/10 day)-		Vision Programmer

**Commercial:**

**Pricing:**

Pricing for project scope as outlined above:

- I. **Multivac Vision Inspection System Total Price** **\$ 150,000.**
- II. Prices quoted are FOB Precision Automation, Cherry Hill, NJ.
- III. Field Service and/or Start-Up assistance as additional scope to the above is available upon request and the following is our current rates:
  - A. Regular hours including portal to portal travel time.
    - 1. Up to 8Hrs/Day \$ 70.00/Hr
    - 2. Plus actual travel and living expenses.
  - B. Weekday overtime hours/or Saturday including portal to portal travel time.
    - 1. Over 8Hrs/Day or Saturday \$ 80.00/Hr
    - 2. Plus actual travel and living expenses.
  - C. Sunday or holiday hours including portal to portal travel time.
    - 1. Anytime \$ 90.00/Hr
    - 2. Plus actual travel and living expenses.

**Payment Terms:**

- I. Progress Payment Terms - The following milestones are suggested to control progress payments with 10% retention:
  - A. 30% of Total upon order placement.
  - B. 30% of Total upon Functional Spec. Approval.
  - C. 30% of Total upon Factory Test.
  - D. 10% of Total upon Installation & Start-Up.
- II. Travel and living expenses for Project Management/Engineering/Programming are not included and will be billed as actual expenses with net 30 payment terms

**Schedule:**

Schedule details are to be developed at the kick off meeting in conjunction with client needs and Precision Automation's backlog. All pricing is based on the following approximate schedule:

- I. Order placement by ~~11/5/99~~.
- II. Functional Specification & approval - 4 weeks after Order (~~approx. 12/3/99~~).
- III. Engineering release to manufacturing - 4 weeks after Functional Spec. approval (~~approx. 12/7/00 incl 1 holiday week~~).
- IV. Manufacturing complete & Factory Test - 5 weeks after Engr. Release (~~approx. 2/11/00~~).
- V. Installation and start up - 2 weeks after Factory Test (~~approx. 2/25/00~~).

October 12, 1999  
Rutgers, The State University of New Jersey

Proposal No. 98-3034R02  
Multivac Vision Inspection System

### **Customer Service Support:**

Precision Automation Co., is committed to providing the necessary support to resolve issues arising from component or equipment failure, errors in workmanship and any warranty related matters. Our equipment is highly reliable and only requires preventive and normal maintenance. Manufacturer's maintenance procedures and recommendations must be followed for efficient operation.

Two levels of service support may be required to respond to operation or maintenance issues. The two levels of service are:

- **Basic Level** - provided by user's operators and maintenance staff. Basic troubleshooting should be performed by plant personnel. Once an issue has been identified, it should be resolved by plant personnel. Precision Automation Co., Inc. should be notified if the source of the issue cannot be identified. Charges may be incurred for Precision Automation Co., Inc. service personnel to handle basic level issues that the user's maintenance staff would usually and reasonably be expected to resolve.
- **Manufacturer Support** - provided by Precision Automation Co., Inc. to address issues associated with programming, controls or mechanical interface; and to handle warranty matters by troubleshooting the equipment to determine the cause. Charges may be incurred if the problem was caused by user personnel's improper operation or care of the equipment or if the problem is of a basic level. Charges will be billed directly to the user to cover any parts, labor, material or expense costs associated with issues not covered by warranty.

No level of support can mitigate the users responsibility that only trained, responsible and dependable personnel operate and maintain the equipment. This policy provides the highest level of assurance that the equipment will perform effectively and reliably.

Additional operator and maintenance training is available at our standard service rates outlined above.

### **General Terms:**

- I. Please Review our "Contract Terms: found in Appendix 1 which are a part of this proposal.
- II. Note the above prices do not include any state or local sales or use taxes. Licenses, permits or fees, if required, are the customer's responsibility.
- III. This proposal is based on a straight time, 40 hours per week basis. Should overtime be requested by Customer, an appropriate extra charge will be required.
- IV. This proposal includes an acceptance run-off at the Precision Automation Co., Inc. plant witnessed by the customer.
- V. The customer shall have a competent technical support staff to operate and maintain the equipment in their facility.

October 12, 1999  
Rutgers, The State University of New Jersey

Proposal No. 98-3034R02  
Multivac Vision Inspection System

- VI. Equipment Operation - Purchaser shall use and shall require its employees to use all safety devices and guards on the equipment. Purchaser shall use safe operating procedures. Purchaser shall not remove or modify any such device or guard or warning sign. If purchaser fails to observe any or all of these obligations, purchaser agrees to indemnify and save Precision Automation Co., Inc. harmless from all liability incurred to persons injured directly by operating the Precision Automation Co., Inc. equipment.
- VII. Modifications or alterations to the equipment without the express written consent of the manufacturer is forbidden. Failure to obtain permission in writing voids any warranty, expressed or implied. It also relieves the manufacturer from all liability for said products.
- VIII. Customer supplied parts shall be to agreed specifications. Precision Automation Co., Inc. cannot be held responsible for equipment operation using out of tolerance components.
- IX. All Utilities are the responsibility of the Customer. Utilities are to be within five (5) feet of the control panels and/or machine connections for the system.

**Appendix I - Contract Terms:**

1. **PRICES** - F.O.B. as specified. All applicable taxes will be added to the price of the equipment and paid by the Purchaser.
2. **SHIPMENT** - Delivery time specified has been calculated pursuant to the nature of the work required and the experience of Precision Automation Co., Inc. in furnishing the equipment of the kind desired by Purchaser; however, any order must be accepted by us with the understanding that delivery time is our best estimate but is not a guaranteed date. Estimate of time of delivery shall date from our acceptance of written purchase order and receipt of full manufacturing details.
3. **TITLE** - Seller retains title to this equipment until full payment is made. Buyer agrees to protect Seller by maintaining full insurance in the amount of the purchase price, as Seller's interest may appear.
4. **WARRANTY** - Seller warrants equipment of its own manufacture to be free from defects in materials and workmanship. This warranty extends only to the original Buyer and is limited to repair or replacement F.O.B. Seller's factory of any original part or component manufactured by Seller which is found by Seller to have been defective at this time of shipment, provided written claim has been received from Buyer within three (3) months of shipment. With respect to equipment, materials, parts and accessories manufactured by others, Seller will undertake to obtain for Buyer the full benefit of the manufacturer's warranties. Seller will not be liable for any loss of profit, loss by reason of plant shutdown, non-operation or increased expense of operation, loss of product or materials, or other special or consequential loss or damage of any nature, and all claims for such loss or damage are expressly waived by Buyer. Buyer hereby agrees to indemnify and save Seller harmless from any and all liability, loss or damage, expense, causes of action, suits, claims or judgments arising from injury to person or property resulting from the use, operation, delivery, or transportation of the equipment. Buyer expressly agrees to indemnify Seller against and hold Seller harmless from any and all claims and causes of action arising out of or relating to any actual or alleged negligent acts of Seller or arising out of or related to any strict liability in tort imposed upon Seller for placing the equipment in the stream of commerce, having any defect or claimed defect. **THIS WARRANTY IS IN LIEU OF ALL OTHER WARRANTIES, EXPRESS OR IMPLIED.**
5. **CANCELLATION** - Cancellation of orders placed and accepted can be made only with our written consent and upon terms which will indemnify us against loss or damages.
6. **APPROVAL** - This Proposal is subject to change without notice. Any order given shall not constitute a binding contract until order has been received at the office of Precision Automation Co., Inc. and accepted by it in writing.
7. **CONFIDENTIAL**- Technical data and layouts supplied by Seller in connection herewith are confidential pending Buyer's acceptance of this Proposal and may not be used without written consent of Seller.
8. **OSHA LAWS** - The Williams-Steiger Occupational Safety and Health Act of 1970 (OSHA) and like state and local laws and all regulations issued under such laws, are designated to assure a safe place to work and apply primarily to the employer, not the equipment manufacturer. Seller will work with Buyer to find technically feasible answers to possible compliance problems; however, because compliance is significantly affected by many factors over which Seller has little control (such as installation, plant layout, building acoustics, materials processed, processing procedures and supervision and training of employees), Seller does not represent or warrant that equipment sold by it complies with OSHA or any like state or local law or regulation, and the cost of modifications and responsibility for compliance are the Buyer's responsibility.

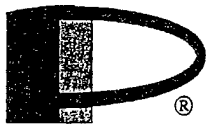

**PRECISION AUTOMATION®**

BOX 18  
HADDONFIELD, NJ  
856-428-7400  
FAX 856-428-1270

May 17, 2000

**Rutgers Multivac Vision Inspection System  
with Reject Mechanism**

**Functional Specification**

**1. Introduction**

Precision Automation Co., Inc. was contracted to provide a machine vision inspection system and reject mechanism to be installed on a Multivac 530 located at the Rutgers CAFT FMTF pilot plant. This system is provided to enhance the machines performance from a quality standpoint. The system will inspect MRE pouches after filling and prior to final heat sealing to identify potential heat seal defects resulting from water droplets, gravy droplets, or solid food pieces in the seal area.

Precision Automation Co., Inc. will be responsible for the design, fabrication, testing and installation of the entire machine vision system. Precision Automation Co., Inc. will partner with Xyntek Inc. Xyntek will provide the machine vision hardware and engineering services necessary to develop and implement the vision inspection solution.

Precision Automation Co., Inc. has been heavily involved in the design phase of this project and has prepared this functional specification which will describe the machines operation. This summary is divided into three sections, Machine Vision Systems, Reject Mechanisms, and System Control, and discussed as follows:

**2. Operation Description**

Sealed MRE pouches will exit the Multivac machine at a rate of 120 per minute in pairs in each of four lanes. The Multivac machine cycle is 4 seconds per eight packages divided into 1.5 second machine index (transfer) and 2.5 seconds dwell.

Signals generated by the Multivac index and dwell positions will control the operation of the vision inspection and reject system.

Eight pouches will be inspected by the vision inspection system during each dwell portion of the Multivac index. The vision inspection system will generate individual Pass/Fail signals for each pouch inspected. The machine control PLC will track these

## **2. Operation Description (con't)**

Pass/Fail inspections from the point of inspection to the reject station at the exit end of the Multivac machine.

Pouches exiting the Multivac machine travel onto a powered four lane conveyor which indexes each time the Multi-Vac machine indexes. During the Multi-Vac dwell period, the pouches are positioned under eight vacuum pick-up units. If any of the pouches are identified as rejects, the reject assembly strokes down and vacuum is initiated at those positions which are rejects. When the reject assembly raises the rejected pouches are lifted from the conveyor. The reject assembly actuates laterally depositing the rejected pouches in a bin located at the side of the conveyor.

## **3. Machine Vision Systems**

Xyntek Inc., a systems application vendor for Cognex, will provide the vision inspection hardware and inspection software required to identify the defective pouches. Xyntek Inc. description of operation is attached for discussion of the machine vision system operational details. Cameras, lighting and shields would be mounted to the Multivac machine.

## **4. Reject Mechanisms**

Referring to Precision Drawing D5895-200, operation of the reject mechanism is as follows :

- 4.1. Pouches exit the Multivac machine via gravity (as presently) and slide down onto a four lane conveyor
- 4.2. The exit conveyor is driven via a power take-off from the Multi-Vac machine which provides an indexing motion for each set of pouches.
- 4.3. Groups of eight pouches (4 lanes by 2 deep) index until arriving at the reject station. The reject station consists of an eight station vacuum pick-up assembly with vertical and horizontal actuation.
- 4.4. If any pouch was identified as a reject (see section 2), the reject assembly will be commanded by the PLC to stroke down.
- 4.5. Vacuum will be initiated in the vacuum cups, by the PLC, at the corresponding reject positions.
- 4.6. The PLC will command the reject assembly to retract lifting any rejects above the conveyor surface.

#### 4. Reject Mechanisms (con't)

- 4.7. The PLC will command the reject assembly to stroke laterally and the vacuum will be turned off at the end of the lateral stroke. The rejects will fall into a reject bin.
- 4.8. Upon the next conveyor index another group of eight pouches will be advanced into the reject station.
- 4.9. Good pouches continue to progress along the conveyor and will be discharged onto a mating pack-out conveyor.

#### 5. System Control

##### 5.1 General

The system control will consist of a vision sub-system, described in the Xyntek Inc. description of operation and the machine control sub-system described below. Both control systems as well as the following major components will be housed within a common control console:

- Cognex vision system consisting of computer, monitor, keyboard and mouse.
- Machine control system PLC and I/O.
- Operator control interface.
- Power distribution for the PLC and vision sub-systems.
- Control relays, terminal strips and power supplies as needed.

The control console will be easily moveable (on wheels) and attached to the Multivac machine by the use of one or more electrical umbilical cords.

##### 5.2 Power Supply

The machine control PLC will receive primary 120 VAC power through a portable line cord, which is plugged into one of the convenience receptacles located on the Multivac machine. The machine control system will derive all required supply voltages for proper operation from this single supply source.

##### 5.3 Multivac Interface

The machine control PLC will interface directly to the Multivac machine by utilizing two discrete signals:

- The "Labeler" output signal from the Multivac machine will be used by the machine control system to synchronize the machine control and vision system activities with the Multivac machine. The Labeler output signal energizes while the index is in progress and de-energizes while in dwell.

- The machine control system will provide a "Synchronization Feedback" signal to synchronize the Multivac machine to the machine control system. The synchronization feedback signal energizes at the beginning of the dwell cycle and de-energize when the vision system has completed its inspection. A key lockable selector switch is provided for the multivac to bypass the synchronization feedback signal in the event the vision system is disconnected or turned off.

These signals will be carried by a common electrical umbilical cable, which is hardwired into the Multivac machine and with a plug on the machine control console end.

#### **5.4 Data Acquisition**

During the start of the dwell portion of an index, the machine control sub-system PLC will signal the vision sub-system to acquire images and test. The vision system will reply to the machine control sub-system with eight discrete "Pass/Fail" signals, one for each pouch, and one common "Data Valid" signal.

The machine sub system will wait for a reply from the vision system until the beginning of the next index. This is approximately 2.5 seconds. If a reply is not received within this time frame, the machine control sub-system optionally will assume all pouches in that position within the machine are bad (fail) or assert the synchronization feedback signal to cause the Multivac machine to pause and wait for the machine control system.

The machine control sub-system will allow only two consecutive no reply's from the vision sub-system before a fault is generated.

#### **5.5 Data Tracking**

The machine control sub-system will track the Pass/Fail status of each pouch in the Multivac from the point of inspection to the reject mechanism. This information will be stored in a shift register within the machine control sub-system PLC. The information held within the shift register will "Shift" each time the machine index starts as sensed by the interface signals described above.

#### **5.6 Sortation**

As pouches approach the reject mechanism, the corresponding Pass/Fail status for each pouch, which is stored within the machine control sub-system PLC shift register, determines the destination of each pouch. The reject sortation cycle begins at the beginning of the machine dwell.

- If one or more pouches were identified as a reject, the machine control PLC will command the Pick-N-Place reject assembly to stroke down.
- The machine control PLC will initiate the vacuum cups at the corresponding reject positions.

- The machine control PLC will command the Pick-N-Place reject assembly to stroke back up thereby lifting any rejects above the conveyor surface.
- The machine control PLC will command the Pick-N-Place reject assembly to stroke laterally. The vacuum will be turned off at the end of the lateral stroke. The rejects will fall into a reject bin.
- Upon the next conveyor index another group of eight pouches will be advanced into the reject station.
- If one or more pouches were identified as a reject, the machine control PLC will again command the Pick-N-Place to cycle however the lateral stroke will be in the opposite direction from the previous Pick-N-Place cycle dropping the rejects into the bin from the opposite side of the conveyor.
- Good pouches continue to progress along the conveyor and will be discharged onto a mating pack-out conveyor.

### 5.7 Operator Interface

Two operator interfaces are provided for the Multivac vision inspection system supplied. Both are housed in the electrical console.

The vision sub-system computer monitor is viewable at all times from the front of the console through a transparent window. The vision sub-system mouse and keyboard will be stowed in a lockable drawer for authorized access only.

A machine control OIT is supplied adjacent to the vision sub-system monitor and is used as the primary operator interface during production. The machine control OIT will incorporate the following minimum functions:

- Vision System Camera 1-4 View Selection Push Buttons - Selects the corresponding camera view to display on the vision sub-system monitor.
- Vision System Graphics View/Hide Push Button - Selects the graphic overlay to display on the vision sub-system monitor.
- Automatic Control - Any operator controls required for automatic operation.
- Manual Control - Any operator controls required for manual operation of reject mechanism.
- Alarm Display - Displays any current alarms or faults.
- Alarm Reset Push Button - Used to reset alarms.
- Setup Screen (password protected)
  - System Bypass - allow the complete bypass of the vision inspection and sortation system. In the bypass mode, all pouches produced would be sent to the exit conveyor and no inspections would be made.

- Synchronization Feedback Enable - Enables the synchronization feedback signal to the Multivac machine to allow the machine control system to pause the Multivac machine.
- Alarm Output - Enables the alarm output dry contact option.
- Time/Date - Sets the current time and date for proper display.

A dual color beacon is also supplied and located on the top of the control console to alert the operator. The beacon contains a red lamp (fault) and a yellow lamp (alarm).

### 5.8 Auxillary Functions

The machine control system will provide one set of dry contacts as an alarm output, which will energize when an alarm condition is present.

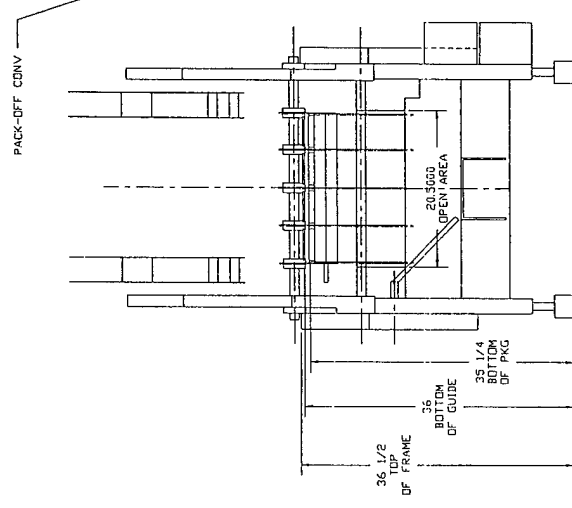
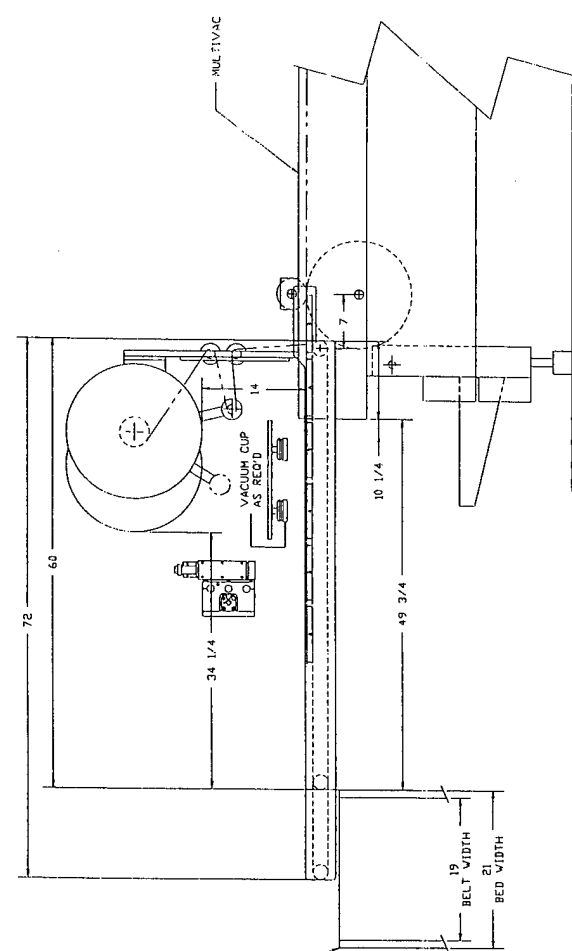
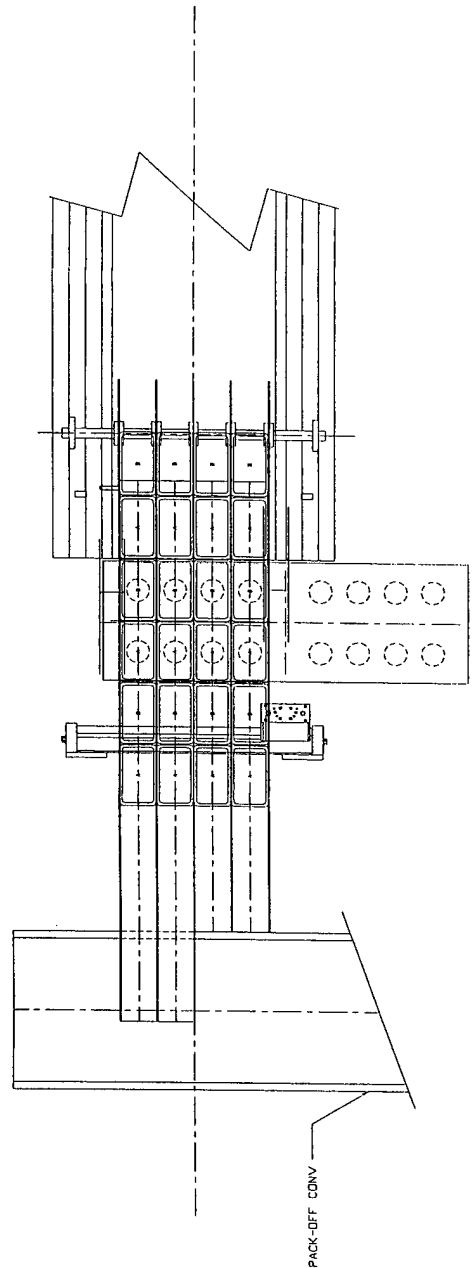

JOB#	QUANTITY	PART DUE DATE	PRIORITY CODE
FIN. INSP.			
PRECISION AUTOMATION COMPANY, INC.			
CHERRY HILL, NJ CLARKSVILLE, IN MACON, GA			
MULTIVAC VISION INSPECTION SYSTEM			
DISCHARGE LAYOUT			
DATE	BY	CHKD BY	APP'D BY
8-2-80	J. Smith		
REV	DESCRIPTION	DATE	BY
0	895-0200		

NO.	DATE	BY	DESCRIPTION

## **Appendix 4.4**

### **Cognex Checkpoint Slides**

# **COGNEX**

## **Checkpoint 900C**

**Blank Pages**

# Checkpoint 900 Overview

---



- **PC-based vision system for factory floor**
- **Grey-scale and color vision systems**
- **High speed inspection, gauging and alignment applications**

**COGNEX**

# Robust Vision Tools

## Color Tools

---

- Includes both color and grey-scale tools
- Color tools are needed to solve applications with subtle color differences
- Color tools can improve traditional grey-scale applications
- Increases the amount of data that you can use to solve vision application
- Color display

COGNEX

# Flexibility in Operator Interfaces.....

**Customizable GUI for easy to use operator control**

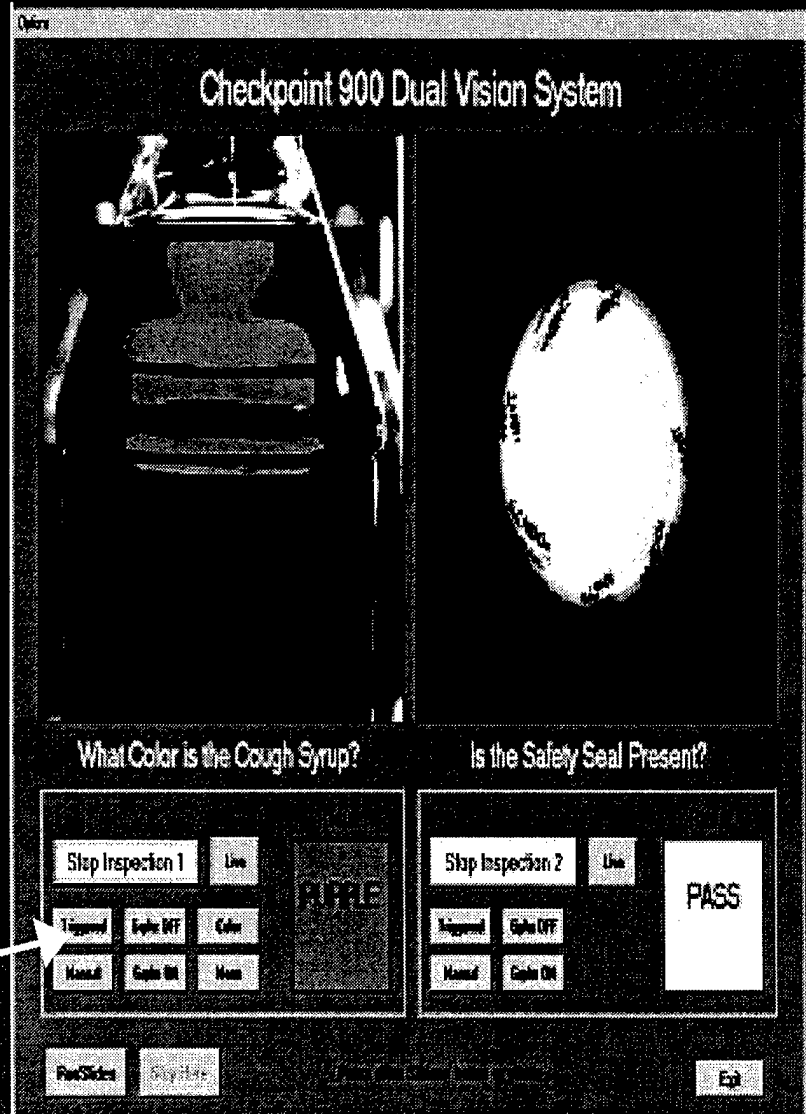

**easy interface**

**COGNEX**

# Communication to Other Devices.....

- **Onboard vision processing frees host CPU to perform other tasks**
  - report generation, motion control, process monitoring, communication and data management
- **Tools available to share vision data with host applications**
  - DDE
  - OLE
  - shared memory

COGNEX

# Summary

---

- **More powerful tools, like color and *PatMax*, enable you to solve more applications**
- **Cognex has the applications experience to ensure reliable solutions**
- **Checkpoint offers highest degree of reliability and flexibility in a factory floor vision system**

COGNEX

## **Appendix 4.5**

### **Economic Analysis, TWP#207**

# **Cost/Benefit Analysis of Machine Vision Pouch Inspection System**

CORANET  
Technical Working Paper, TWP #207

T.O. Boucher  
N. Litman

Rutgers University  
May 1999

## **Abstract**

This paper describes a rigorous economic feasibility analysis of a machine vision inspection system added to an existing horizontal form-fill-seal packaging line. The vision system is to identify product contamination on the surface of the package heat seal area prior to closing. A reject mechanism removes defective packages as they are discharged from the line. Primary economic factors for the machine vision system are; the capital and operational costs; and benefits from reduced inspection labor and rework of rejected lots. A case study and data tables are provided to facilitate making an economic justification under a range of situations.

## **1.0 Introduction and Background**

STP #1007 began on March 3, 1997 based on a technical proposal dated December 19, 1996. The objective of this project is to demonstrate a multi-camera, full production machine vision pouch inspection system installed on a production Multivac horizontal form-fill-seal line. An earlier prototype system was successfully demonstrated at the CRAMTD End of Contract Briefing in 1996.

One of the requirements under STP #1007 is to demonstrate the economic feasibility of the machine vision system through a cost/benefit analysis. This is the purpose of this technical working paper.

## **2.0 Economics of Machine Vision Seal Inspection**

Precision Automation, the system integrator on this project, has established that additional systems can be purchased for approximately \$120,000 each. This capitalization cost has to be justified based on benefits to be obtained from the use of the vision system. In this section we will discuss the economic bases of these benefits.

The equipment performance specifications are identical to the prototype machine vision inspection system. The imaging requirements of prototype system have been demonstrated effective for detecting seal area contaminants that could diminish seal width to less the minimum required for MREs. Accuracy of the system for correctly identifying such contamination exceeds 95%.

## **2.1 Reduction in Direct Labor During Production**

Current practice for pouch inspections includes two 100% inspections. One inspection is performed immediately after the pouch has been sealed. A second inspection is performed when pouches are inserted into cartons. The machine vision inspection system will impact the requirements of inspection immediately after the pouch has been sealed. Manual inspection of contaminated seals will no longer be needed since these defects will be removed from the production line by the automated rejection system. Food materials can be reworked prior to retort processing but not after. We estimate that the elimination of seal area inspection should reduce the required direct labor on the line by three inspectors. Inspection for other defects such as abrasion will be accomplished by the remaining three line operators. We have used this number as a baseline for the reduction in direct labor which will result from the replacement of manual inspection of seal area by machine vision.

## **2.2 Re-inspection Cost Reduction**

The second major area of economic benefits is re-inspection cost reduction. Figure 1 is a block diagram that illustrates the inspection and re-inspection cycle for MRE pouches. The initial inspection (Block 1.0) requires a producer to perform a visual examination of 200 pouches and perform destructive testing on 64-132 pouches for various defects, including seal integrity. If the producer judges the lot to be conforming, it is then submitted to a verification test by USDA (Block 2.0). The same series of tests are repeated. If the lot is accepted, it is shipped to the assembler. From this point on, in the normal course of events, the lot will enter the military distribution system.

If the USDA verification tests find that the lot is nonconforming, it will be subject to re-inspection. The events of the re-inspection process depend on whether the lot is rejected for a “critical” defect or for a “major or minor” defect. Seal integrity is considered a critical defect. Recent rejection data reported by the USDA for seal integrity is about 16% (11 of 67 lots rejected due to entrapped matter and open seals). An additional 5% rejection rate occurs due to internal pressure, which may also be caused by seal integrity problems. These statistics are based on HFFS pouches produced for MRE 18 & 19 through March 2, 1999. The defect rate data reflects start up problems of new Multivac production lines, we can expect improvement as producers gain experience.

When a critical defect occurs, the QC manager must develop a rework plan and have it approved by the USDA inspector (Block 3.0) and DSCP. In a typical rework plan for a critical defect, the rework plan requires the producer to remove all pouches from their cartons, re-inspect the pouches, and re-carton the pouches (Block 4.0). This is followed by returning to the beginning of the inspection process (Block 1.0).

Based on the above description, the following cost factors for the producer are associated with re-inspection due to a critical defect:

1. Management time: the additional time spent by the QC manager and/or other management personnel in developing a rework plan (Block 3.0).
2. Rework labor time: the labor and supervisor time associated with removing pouches from cartons, re-inspecting pouches, and replacing the pouches back into new cartons (Block 4.0).
3. Rework material cost: cartons that are opened during re-inspection have their seals destroyed. Pouches recycled through the packaging machine are sealed in new cartons. This represents an additional material (packaging) cost for each opened carton. We are assuming that a lot size is approximately 20,000 pouches in our baseline analysis.
4. Producer re-inspection labor: this is the additional time for the second in-house inspection of the lot (Block 1.0).
5. Producer re-inspection material: this is the additional pouches destroyed during the process of end item testing for the second time (Block 1.0) and USDA verification test (Block 2.0).

**Figure 1. MRE Lot Inspection**

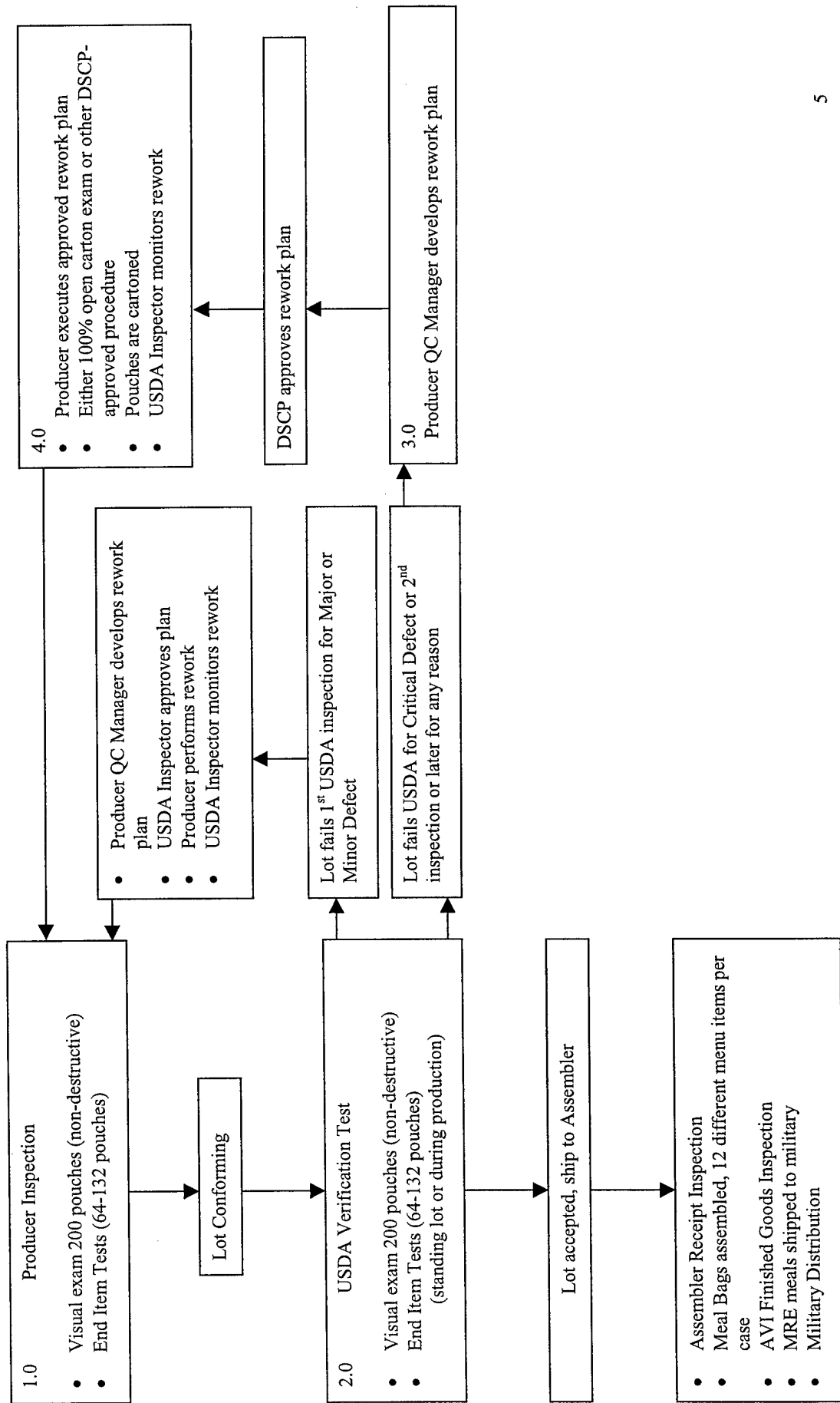

**Blank Pages**

### **2.3 Difficult-to-Quantify Benefits**

In sections 2.1 and 2.2 we discussed costs that can be avoided by using the proposed machine vision system. Those costs are relatively easy for a producer to estimate based on his or her experience. In this section we list some other benefits that are not as easy to quantify but that, nonetheless, are important considerations in choosing a vision system over current practices of manual inspection.

1. Immediate feedback on production line: the automation of the seal inspection process will provide immediate feedback of out-of-tolerance conditions. This enables the machine operator to take immediate corrective action.
2. Improved documentation of seal condition: a machine vision system can allow the producer to collect seal integrity data automatically and use this documentation for internal evaluation or to be presented to DSCP as part of the lot quality record.
3. Impact on reputation (best value analysis): the reduction or elimination of seal defects will improve the producers chances of receiving future contracts based on DSCP evaluation procedures of best value analysis.
4. Government-incurred costs: in sections 2.1 and 2.2 we focused entirely on the costs to be avoided by the producer. Seal integrity failures also incur costs in additional USDA inspections and will result in costs to the military consumer if failures are discovered in the field.

Because the costs listed above are less directly traceable, they are termed “difficult-to-quantify”. However, some value should be placed on these factors by management when considering the overall benefits of machine vision for seal integrity inspection.

### **3.0 Economic Analysis and Case Study**

In this section we use the benefits identified in section 2 and illustrate the economic justification for capital investment in machine vision for seal integrity inspection. First we describe a model that may be used by a producer to estimate the return on investment for the proposed capital investment. Second, we illustrate the use of the model in a case study of a hypothetical producer.

### 3.1 Economic Model

Our evaluation method is based on three well-known methods used by managements in assessing capital investments.

1. Payback period: this measure is defined as the period of time it takes to recover the initial capital investment.
2. Internal rate of return (IRR) on investment: this measure defines the discount rate that equates the value of the benefits arising from the investment over the life of the project to the initial coat of the investment. If the IRR is greater than the investment hurdle rate used by the firm to screen investments, then the investment is acceptable.
3. Benefit to cost (B/C) ratio: This is the ratio of the future benefits of the investment (discounted at a market borrowing rate) to the cost of the investment. A ratio greater than 1.0 indicates an acceptable investment.

Tables 1, 2, and 3, below, are look up tables that can be used by a producer to locate the appropriate values of the above measures for the proposed investment in machine vision. Here we describe the bases for these tables.

It is assumed that an average producer has a production quantity of 200 lots per year, where a lot size is 20,000 pouches (a day's production). Based on this level of production, Tables 1-3 are constructed with the following assumptions:

1. The vision system will replace 3 inspectors who earn an average hourly wage (with benefits) of \$7.50. This is the direct labor reduction assumption made in section 2.1.
2. The vision system will result in cost savings other than direct labor as given by the dollar values across the top of each table under the category "ESTIMATED COST SAVINGS PER REJECTED LOT". This comes from the benefits discussed in sections 2.2 and 2.3.

The tables are used as follows. The first column shows a range of possible percent reductions in rejected lots to be achieved by the producer when investing in the vision system. Thus, if a producer is currently experiencing an 8% reject rate based on seal integrity, which he expects to eliminate using the vision system, the row labeled "8%" is the appropriate row for that producer.

The second column lists the expected reduction in the number of rejected lots. Since we have assumed a production rate of 200 lots per year, eliminating an 8% reject rate is equivalent to a reduction of 16 rejected lots per year.

Columns 3-7 are based on estimates of dollar benefits from the categories of benefits identified in sections 2.2 and 2.3. These estimates must be made by the producer based on his or her own experience. Continuing with our example, if the producer estimates that eliminating seal integrity problems will result in avoiding re-inspection and related costs of about \$2000 per rejected lot, then the relevant column for that producer is the fifth column. The intersection of “Percent reduction in rejected lots” = 8% and “Estimated cost savings per rejected lot” = \$2000 is the appropriate cell in the table for that producer. In this case the payback period is 2.4 years, the after tax internal rate of return is 34%, and the benefit to cost ratio is 1.9.

Tables 1-3 are based on straightforward calculations using conventional financial methods. An example of these calculations is given in Appendix 1. The use of Tables 1-3 requires that the producer compute an estimate of the magnitude of the benefit under “Estimated cost savings per rejected lot”. These cost savings come from the benefit categories described in sections 2.2 and 2.3. We will illustrate a sample calculation in the case study given in the next section.

### 3.2 Case Study

Producer A has a 5% reject rate due to seal integrity problems. This typically results in rework based on the rework cycle shown in Figure 1. Following sections 2.2 and 2.3, Producer A has calculated the following cost.

1. Management time: when a lot is rejected, the QC manager spends about a half a day developing the rework plan with the USDA inspector. Based on the QC manager's salary, the cost is estimated as \$200 per lot.
2. Rework labor time: to re-inspect and re-package the lot, QC uses a group of 6 inspectors for a day. They remove pouches from cartons, re-inspect, and re-carton the pouches. At an average wage of \$7.50 per hour, this cost is estimated at \$360 per lot.
3. Rework material cost: the lot size is approximately 20,000 pouches. Therefore, there are 20,000 cartons destroyed during rework. Each carton costs 7.5 cents. This cost is estimated as \$1500 per lot.
4. Producer re-inspection labor: The visual re-inspection of 200 pouches and the destructive testing of approximately 100 pouches takes one inspector about a day. This cost is estimated at \$60 per lot.
5. Producer re-inspection material: The producer re-inspection an USDA validation tests result in the destruction of 200 pouches. The producer revenue for each pouch is \$1.50. This cost is estimated at \$300 per lot.

6. Difficult-to-quantify cost: Management believes that a superior record for seal integrity will enable them to be a preferred source. A very conservative estimate is made that this will result in a 1% increase in contracts awarded to them. This is an increase, on average, of 2 lots per year. The producer receives a profit of \$0.25 per pouch. At 20,000 pouches per lot, this yields additional profit of 10,000 per year. Since the estimated reduction in rejected lots due to the investment in machine vision is 10 lots, the expected annual cost savings (additional profit) per rejected lot is \$1,000.

#### **Estimate of Cost Savings Per Rejected Lot for Case Study**

1. Management time	\$ 200
2. Rework labor time	360
3. Rework material cost	1,500
4. Re-inspection labor	60
5. Re-inspection material	300
6. Difficult-to-quantify	<u>1,000</u>
Total	3,420

Using Tables 1-3, the payback period is slightly less than 2.5 years, the IRR is slightly greater than 33%, and the benefit-to-cost ratio is slightly in excess of 1.8.

#### **4.0 Conclusion**

Implementation of a machine vision inspection system will generate a significant cost reduction for the MRE producer that is clearly justified by this cost/benefit analysis. The typical MRE producer should recover the cost of a vision inspection system within three years. Additional benefits will be realized by the MRE assemblers and the military.

## Vision System Seal Defect Detection System: Payback periods and project internal rate of return on investment

**Assumptions:**

1. Production quantities = 200 lots/year.
2. Vision system replaces 3 inspectors at \$7.50 per hour.
3. Vision system costs: purchase and installation = \$120,000; maintenance = \$5000/year
4. Marginal tax rate (federal + state) = 38%.
5. Contractor cost per rejected lot and number of rejected lots avoided per year as given in tables.

**Table 1 Payback Period**

### ESTIMATED COST SAVINGS PER REJECTED LOT

Percent Reduction in Rejected Lots	Number of Rejected Lots per Year Avoided	ESTIMATED COST SAVINGS PER REJECTED LOT				
		\$500	\$1000	\$2000	\$3000	\$4000
5%	10	3.9 yrs.	3.5 yrs.	2.9 yrs.	2.5 yrs.	2.2 yrs.
8%	16	3.7 yrs.	3.1 yrs.	2.4 yrs.	2.0 yrs.	1.7 yrs.
10%	20	3.5 yrs.	2.9 yrs.	2.2 yrs.	1.8 yrs.	1.5 yrs.
12%	24	3.4 yrs.	2.7 yrs.	2.0 yrs.	1.6 yrs.	1.3 yrs.
14%	28	3.2 yrs.	2.6 yrs.	1.9 yrs.	1.5 yrs.	1.2 yrs.

**Table 2 Internal Rate of Return on Investment of \$120,000**

### ESTIMATED COST SAVINGS PER REJECTED LOT

Percent Reduction in Rejected Lots	Reduction in Number of Lots per Year Rejected	ESTIMATED COST SAVINGS PER REJECTED LOT				
		\$500	\$1000	\$2000	\$3000	\$4000
5%	10	15%	19%	26%	33%	39%
8%	16	18%	23%	34%	44%	53%
10%	20	19%	26%	39%	51%	62%
12%	24	21%	29%	44%	58%	71%
14%	28	22%	31%	48%	64%	80%

Table 3 Benefit to Cost Ratio (10% after tax cost of funds)

ESTIMATED COST SAVINGS PER REJECTED LOT

Percent Reduction in Rejected Lots	Reduction in Number of Lots per Year Rejected	\$500	\$1000	\$2000	\$3000	\$4000
5%	10	1.2	1.3	1.6	1.8	2.1
8%	16	1.3	1.5	1.9	2.3	2.7
10%	20	1.3	1.6	2.1	2.6	3.1
12%	24	1.4	1.7	2.3	2.9	3.5
14%	28	1.4	1.8	2.5	3.2	3.9

## APPENDIX 1

**Example Calculation:** (5% reduction in rejections, \$2000 cost savings per rejected lot)

	YEAR						
Before Tax:	1	2	3	4	5	6	7
1. Initial Investment							
2. Maintenance	\$ (5,000)	\$ (5,000)	\$ (5,000)	\$ (5,000)	\$ (5,000)	\$ (5,000)	\$ (5,000)
3. Labor cost savings (1)	36,000	36,000	36,000	36,000	36,000	36,000	36,000
4. Depreciation rate (2)	0.2500	0.2143	0.1531	0.1093	0.0875	0.0874	0.0875
5. Depreciation amount	30,000	25,716	18,372	13,116	10,500	10,488	10,500
6. Re-inspection cost savings (3)	20,000	20,000	20,000	20,000	20,000	20,000	20,000
After Tax:							
7. Maintenance (4)	(3,100)	(3,100)	(3,100)	(3,100)	(3,100)	(3,100)	(3,100)
8. Labor cost savings (5)	22,320	22,320	22,320	22,320	22,320	22,320	22,320
9. Depreciation savings (6)	11,400	9,772	6,981	4,984	3,990	3,985	3,990
10. Reinspection cost savings (7)	12,400	12,400	12,400	12,400	12,400	12,400	12,400
<b>Total Cost Savings</b>	43,020	41,392	38,601	36,604	35,610	35,605	35,610
<b>Cumulative cost savings</b>	43,020	84,412	123,013	159,617	195,227	230,832	266,442
<b>Discounted savings (26%)</b>	\$ (120,000)	34,143	26,072	19,297	14,523	11,213	7,063
<b>Discounted savings (10%)</b>		39,109	34,208	29,002	25,001	20,098	18,274

(1) 200 lots x 8 hrs./lot x 3 inspectors x \$7.50 per hr.

(2) 7-year asset MACRS depreciation rate, mid quarter convention.

(3) \$2000 per lot x 10 lots.

(4) Row 2 x 0.62

(5) Row 3 x 0.62

(6) Row 5 x 0.38

(7) Row 6 x 0.62

**B/C = 187,803/120,000 = 1.6**