

REPORT DOCUMENTATION PAGE

Form Approved

Public reporting burden for this collection of information is estimated to average 1 hour per response, including the time for gathering and maintaining the data needed, and completing and reviewing the collection of information. Send comments regarding this burden estimate or any other aspect of this collection of information, including suggestions for reducing this burden, to Washington Headquarters Services, Directorate for Information Operations and Reports, 1215 Jefferson Davis Highway, Suite 1204, Arlington, VA 22202-4302, and to the Office of Management and Budget, Paperwork Reduction Project (0704-0188).

AFRL-SR-BL-TR-01-

0259

1. AGENCY USE ONLY (Leave Blank)	2. REPORT DATE 01/04/01	3. REPORT TYPE AND PERIODICITY Final	
4. TITLE AND SUBTITLE Optical Amplifiers based on Vibronic Transitions for Broadband Telecommunications		5. FUNDING NUMBERS	
6. AUTHORS P. J. Delyett, B. H. T. Chai, P. LiKamWa, and H. Janssen			
7. PERFORMING ORGANIZATION NAME(S) AND ADDRESS(ES) School of Optics/CREOL - University of Central Florida 4000 Central Florida Blvd. Orlando, FL 32816-2700		8. PERFORMING ORGANIZATION REPORT NUMBER F49620-96-0229	
9. SPONSORING / MONITORING AGENCY NAME(S) AND ADDRESS(ES) Wendy Veon, Administrative Contracting Officer Department of the Air Force Air Force Office of Scientific Research 801 North Randolph Street, Room 732 Arlington, VA 22203-1977		10. SPONSORING / MONITORING AGENCY REPORT NUMBER	
11. SUPPLEMENTARY NOTES			
12a. DISTRIBUTION / AVAILABILITY STATEMENT <i>APPROVED FOR PUBLIC RELEASE, DISTRIBUTION UNLIMITED</i>		<p style="text-align: center; font-weight: bold;">AIR FORCE OFFICE OF SCIENTIFIC RESEARCH (AFOSR) NOTICE OF TRANSMITTAL DTIC: THIS TECHNICAL REPORT HAS BEEN REVIEWED AND IS APPROVED FOR PUBLIC RELEASE UNLESS INDICATED OTHERWISE. DISTRIBUTION IS UNLIMITED.</p>	
13. ABSTRACT (Maximum 200 words) The aim of this multidisciplinary research project is to investigate and develop compact and cost effective broadband optical amplifiers that operate in 1.3 μ m wavelength band. Our approach is based on vibronic solid state laser materials that are used to fabricate guided-wave structures to optimize the high intensity optical interaction distance in the crystals. The successful outcome of this program could lead to a competitive optical network system operating at 1.3 μ m that would complement future 1.55 μ m optical networks.			
14. SUBJECT TERMS		15. NUMBER OF PAGES 8	
		16. PRICE CODE	
17. SECURITY CLASSIFICATION OF REPORT	18. SECURITY CLASSIFICATION OF THIS PAGE	19. SECURITY CLASSIFICATION OF ABSTRACT	20. LIMITATION OF ABSTRACT

20010430 082

--	--	--	--

NSN 7540-01-280-5500

Standard Form 298 (Rev. 2-89)
Prescribed by ANSI Std. Z39-1
298-102

Optical Amplifiers based on Vibronic Transitions for Broadband Telecommunications

P. J. Delfyett, B. H. T. Chai, P. LiKamWa, and H. Jenssen
CREOL, University of Central Florida, 12424 Research Parkway, Orlando, FL 32826

ABSTRACT

The aim of this multidisciplinary research project is to investigate and develop compact and cost effective broadband optical amplifiers that operate in 1.3 μm wavelength band. Our approach is based on vibronic solid state laser materials that are used to fabricate guided-wave structures to optimize the high intensity optical interaction distance in the crystals. The successful outcome of this program could lead to a competitive optical network system operating at 1.3 μm that would complement future 1.55 μm optical networks.

TECHNICAL

General Background

Recently, photonics has emerged as the critical enabling technology in telecommunications, data networking, and ultrahigh speed optical signal processing. The broad bandwidth that optical fiber provides is unsurpassed as compared to other secure communications channels. Present telecommunication data rates are beginning to approach rates of several gigabits per second, however, with the advent of new high bandwidth services, these data rates will be unacceptable as the user requirements expand. Most recently, optical amplifiers, such as semiconductor traveling wave optical amplifiers, and erbium doped fiber amplifiers, have been suggested and used as photonic amplifiers in several network configurations and topologies. These devices and approaches, while revolutionizing present-day telecommunications, continue to possess drawbacks which limit their deployment into the terrestrial communication network. For example, semiconductor optical amplifiers, while electrically efficient, suffer from pattern dependent effects, leading to increased bit error rate transmission. Erbium amplifiers, which possess long upper state lifetimes, are typically immune to pattern dependent effect, especially when the data rate is faster than the gain recovery time. However, the terrestrial network being employed by current telecommunication carriers utilize standard fiber with a minimum dispersion at 1.3 μm . Thus, erbium amplifiers, which operate at 1.55 μm , could be employed as simple linear gain blocks, non-regenerative repeaters or receiver pre-amplifiers. However, in this case, the dispersion owing to the optical fiber would temporally broaden transmitted optical signals. This effect would either i) limit repeater distance, ii) increase bit error rate, iii) require the use of high speed electronic components for repeaters, or iv) require novel optical dispersion compensation techniques. Thus, employing erbium amplifiers in the current terrestrial fiber would reduce the limiting effects associated with signal loss, however, the network would require additional technologies to overcome limitations associated with dispersive effects.

In this project, we have been investigating solid state laser media as candidates for optical amplifiers that operate at the important telecommunication wavelength of 1.3 μm . The materials that possess the largest spectral bandwidth centered around 1.3 μm are Cr^{4+} doped LiAlO_2 and LiGaO_2 . These crystals have broad absorption bands in the visible and near IR, allowing for efficient diode pumping. Emission from $\text{Cr}^{4+}:\text{LiAlO}_2$ shows strong luminescence centered near 1.3 μm , with a 32 μs decay time. Another crystal that is highly suitable for such application is the $\text{Cr}^{4+}:\text{Ca}_2\text{GeO}_4$ (Cunyite). The material that we are using in this project has been provided to us by Professor Petricevik at the City University of New York. The Cunyite also possesses a broadband absorption band in the visible and near-IR region and the emission centered around 1.4 μm has a useful bandwidth larger than 150nm.

This program has been focusing on the growth of high quality bulk single crystals to characterize the small signal gain and the fabrication of guided-wave structures to efficiently extract large optical gain from the crystals.

SUMMARY OF ACCOMPLISHMENTS TO DATE

- Successful growth of single crystal $\text{Cr}^{4+}:\text{LiAlO}_2$
- First observation of optical gain in $\text{Cr}^{4+}:\text{LiAlO}_2$
- PECVD grown silicon oxynitride waveguides have been fabricated directly on top of the crystal substrates.
- Demonstrated single mode waveguiding of 1.3 μm light
- Demonstrated post processing by annealing in an oxygen rich atmosphere to enhance optical gain.
- Excitation spectroscopy indicates efficient pumping pathways for primary luminescence.
- Observation of large optical gain in $\text{Cr}^{4+}:\text{Ca}_2\text{GeO}_4$.
- Demonstrated guided-wave fluorescence from a slab dielectric waveguide fabricated directly on a $\text{Cr}^{4+}:\text{LiAlO}_2$.
- Measurement of optical gain at 1.28 μm in a single mode rib dielectric waveguide fabricated directly on a $\text{Cr}^{4+}:\text{LiAlO}_2$.
- Measurement of optical gain at 1.28 μm in a single mode rib dielectric waveguide fabricated directly on a Nd:SFAP substrate.

EXPERIMENTAL WORK

During this past phase of the project, we have concentrated our efforts on the fabrication of low loss waveguiding structures that can enable efficient extraction of optical gain from the solid state crystals. In our earlier reports we have experimented with zinc in-diffused waveguides and

proton exchanged waveguides in the LiAlO₂ crystals. Unfortunately, the changes in refractive index achieved using these techniques are insufficient to produce tightly confined waveguides. Consequently, a different approach of fabricating thin film silicon oxynitride waveguides directly on the surface of the gain media has been implemented. Both the pump laser beam at 800nm and the signal beam at 1300nm are guided in the oxynitride waveguides. The waveguides are designed to have a significant evanescent field overlap with the substrate. The energy exchange is obtained by the absorption of the pump energy carried in the evanescent tail of the pump mode and the amplification of the signal beam is also a result of interaction of the tail of the guided mode with the optically inverted gain medium. This approach allows us to fabricate high quality low loss dielectric waveguides independent of the gain medium used.

Thin film dielectric waveguide for evanescent wave coupling into the active medium.

The critical parameter in the design of these waveguides is optimization for high overlap integral between the evanescent tails of the guided modes of the pump beam and signal beam respectively. For instance, with a waveguide geometry outlined in figure 1, the slowly varying

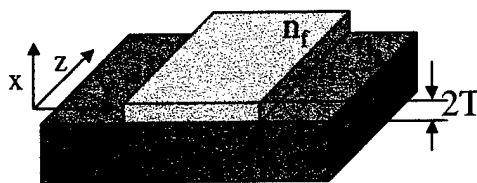

Figure 1. Schematic drawing of thin film waveguide

envelope approximation give the following solution to the 1-D Maxwell wave equation.

For TE guided waves,

$$E_y = \begin{cases} A \sin(\kappa_x T + \phi_x) \exp[-\gamma_a(x-T)] \sin(\kappa_{y,n} W + \phi_{y,n}) \sin(\kappa_{y,n} y + \phi_{y,n}) & x > T, -W < y < W \\ A \sin(\kappa_x x + \phi_x) \sin(\kappa_{y,n} y + \phi_{y,n}) & -T < x < T, -W < y < W \\ A \sin(-\kappa_x T + \phi_x) \exp[-\gamma_s(x-T)] \sin(\kappa_{y,n} W + \phi_{y,n}) \sin(\kappa_{y,n} y + \phi_{y,n}) & y < -T, -W < y < W \end{cases}$$

where A is a normalization constant, κ_x , $\kappa_{y,n}$ are the propagation constants in the x - and y -directions respectively, n denotes the mode number in the y -direction. γ_a and γ_s are the phase propagation constants of light in air and substrate respectively.

Because only the tail portion of the pump mode overlaps with the substrate material, the effective absorption coefficient of the waveguiding structure is given by,

$$\alpha_n = \frac{\mu_o \omega_p A^2 \sin^2(-\kappa_x T + \phi_x) \sin^2(\kappa_{y,n} W + \phi_{y,n})}{\beta \cdot 2\sqrt{\beta^2 - n_s^2 k_o^2}} n_s k_o \alpha_s$$

where ω_p is the pump angular frequency, α is the bulk absorption coefficient of the substrate and β is the propagation constant in the z -direction.

The spatial distribution of the dielectric constant at the signal frequency is given by,

$$\epsilon(x, y, z) = \epsilon_o(x, y) + \epsilon_p(x, y, z)$$

where ϵ_p is the perturbation in the field distribution arising from the presence of the active medium and is given by,

$$\epsilon_p(x, y, z) = j \frac{2\omega_p \mu_o \exp(-\alpha_n z)}{\beta} \chi_p E_y^2$$

and χ_p is the proportionality constant that relates the induced change of the imaginary part of the dielectric constant of the active substrate to the electric field pump intensity at the signal frequency.

The amplitude gain coefficient of the optical signal is then,

$$\Gamma \propto \exp \left[\int_0^z E_y^s \epsilon(x, y, z) E_y^{s*} dz \right]$$

where E_y^s is the electric field component of the TE mode of the optical signal.

By calculating the mode profiles, we can determine the overlap integral of the evanescent part of the signal beam that propagates in the active medium. Figure 2 shows the calculated overlap integral as a function of the thickness of the waveguide for several films of different refractive indices.

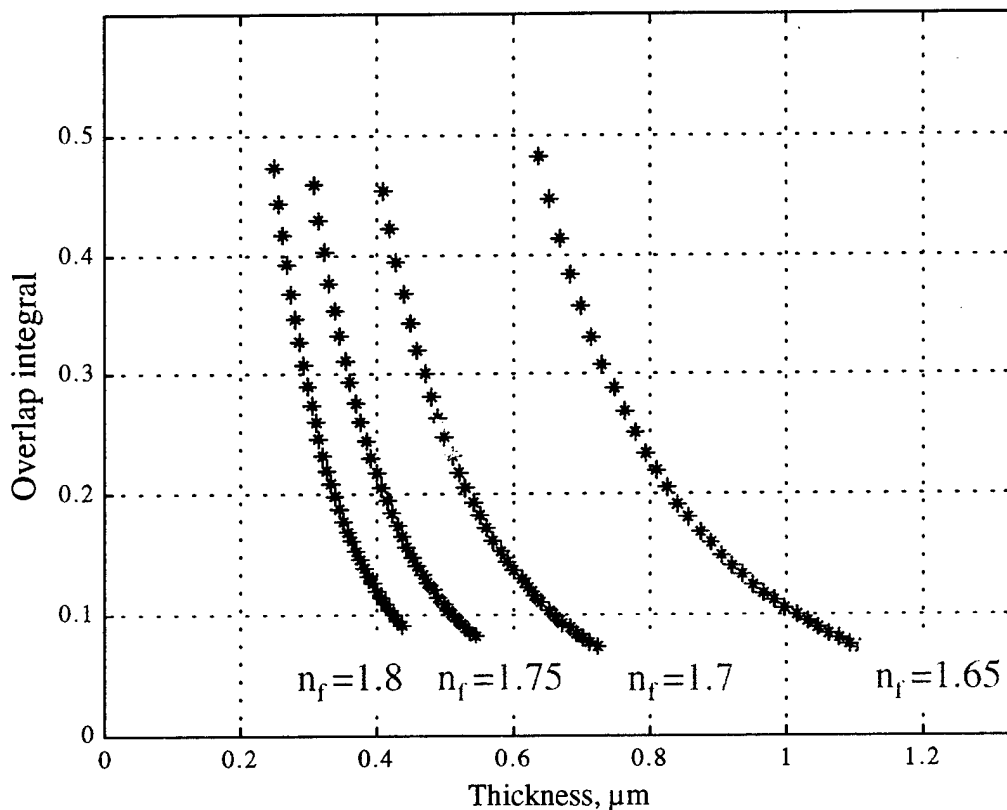

Fig. 2. Overlap integral vs. thickness of the guiding layer for different indices of refraction, n_f

It is evident from figure 2 that the overlap integral is quite small (< 50%). However, the guided-wave structures enable the gain to be extracted over a longer interaction distance (> 1cm) refractive index of the film is critically important in ensuring optimal extraction of gain from the active medium.

Measurement of the refractive index of dielectric films

In order to evaluate the refractive index of an individual PECVD silicon oxynitride film, a prism coupling technique is employed. The set-up is shown schematically in figure 3. The principle of this measurement technique uses the fact that a thin film that is deposited on a substrate of known refractive index will guide a mode with a specific angle of acceptance within the film. By placing a prism on top of the film and measuring the angle at which coupling to the waveguide mode occurs, an accurate measurement of the refractive index of the film can be determined if the thickness of the film is known to a high degree of precision. The thickness of the film is determined by etching a step in the film and measuring the height of the step using a Tencor step profiler.

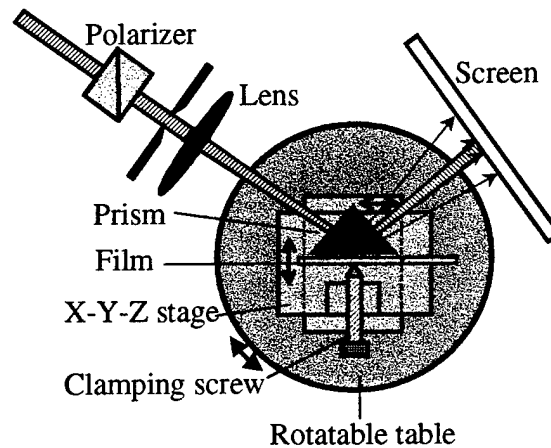

Fig. 3. Schematic drawing of set-up for measuring the refractive index of the dielectric films

Using the above set-up, the PECVD growth of the silicon oxynitride films was characterized. By controlling the ratio between the gases (N_2O and NH_3) that are used during the growth, the refractive index of the deposited film can be manipulated. Figure 4 shows that the refractive index can be varied continuously from 1.59 to 1.71 when the ratio of nitrous oxide to ammonia is changed from 1 to 2.9.

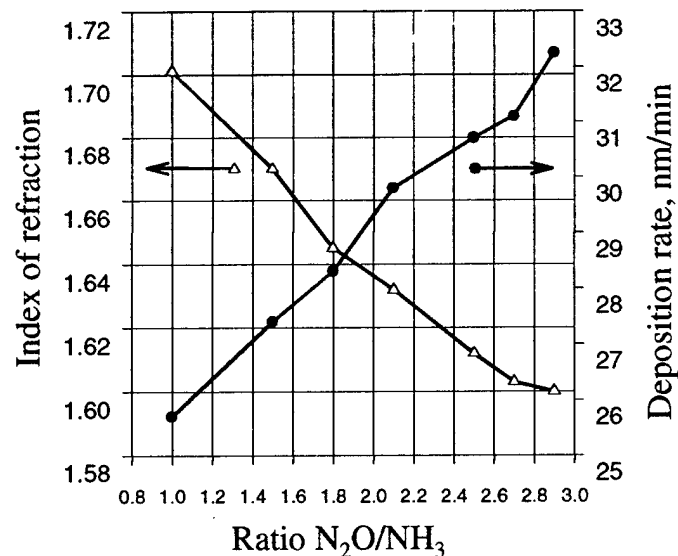

Fig. 4. Characteristics of silicon oxynitride films as a function of N_2O/NH_3 ratio.

Using the knowledge of the refractive index for Cr:LiAlO₂ a single mode slab waveguide of thin film of silicon oxynitride was designed and fabricated by PECVD on a Cr:LiAlO₂ substrate. The sample was diced and the two opposite ends were polished on a polishing pad with 0.3μm alumina grit. The waveguide was tested for waveguiding using the end-fire coupling technique. The source of the 1.28μm optical signal was a Ti:sapphire pumped Nd:SFAP laser. The laser beam was focused onto the input facet of the device using a x40 microscope objective lens. The output facet was imaged onto an infrared vidicon camera using another x40 microscope objective lens. The image was captured using a computer frame grabber. The device was then pumped directly using the beam from the Ti:sapphire laser tuned at a wavelength of 750nm. The image of the output facet viewed through a 2mm thick silicon filter, revealed strong fluorescence of the crystal being guided by the thin film waveguide (0.6μm thick) as shown in figure 5.

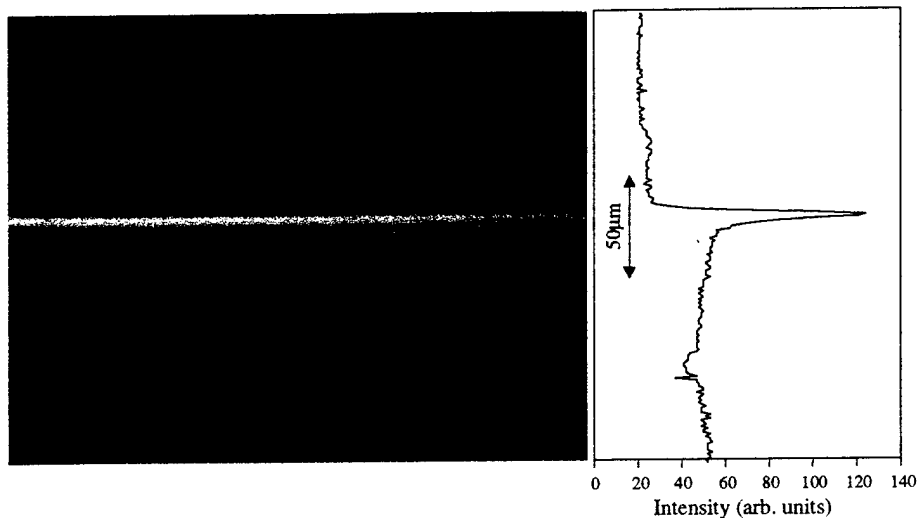

Figure 5. Image of fluorescence emission from the Cr⁴⁺:LiAlO₂ crystal / waveguide structure.

Then single mode waveguides were fabricated by etching ribs structures out of the thin film slab waveguide. The single mode waveguides were cut and polished to an overall length of 3mm and were again pumped end-on using the beam from the Ti:sapphire laser. Figure 6 shows the top view image of one of the waveguides being launched with 750nm wavelength pump laser beam.

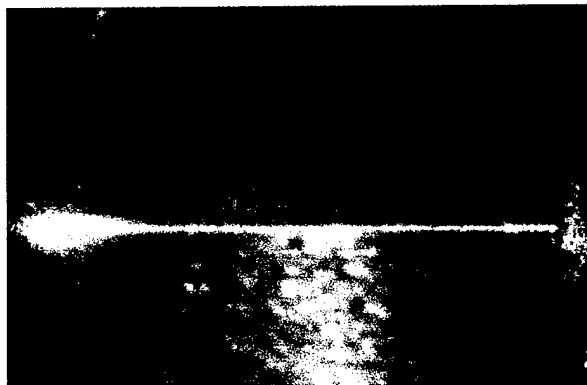

Fig. 6. Top view picture of waveguide excited with 750nm pump laser.

Figure 7 shows the fluorescence emission through the output facet of the single mode waveguide imaged through a silicon filter onto an infrared vidicon camera.



Fig. 7. Picture of the fluorescence emission at the output facet of the single mode waveguide

The $1.28\mu\text{m}$ signal beam from the Nd:SFAP laser was mechanically chopped and then launched into the single mode waveguide that was simultaneously being pumped by the Ti:sapphire laser. The transmitted signal beam was monitored using a Ge photodetector connected to a lock-in amplifier. By blocking and unblocking the pump beam from the device, it was observed that the transmitted $1.28\mu\text{m}$ optical signal increased in intensity by 10% when the pump beam was present. The available pump intensity was 400mW and only 40mW was estimated to be actually coupled into the single mode waveguide. The absorbed pump power was only up to $400\mu\text{W}$ owing to the small overlap integral of the waveguide mode with the active substrate. The remainder of the energy was scattered by the high density of defects that were present in the $\text{Cr}^{4+}:\text{LiAlO}_2$ material. In fact, the high defect density level in this material proved to be the most difficult stumbling block to the realization of efficient $1.3\mu\text{m}$ guided-wave optical amplifiers. It turned out that in order for the Cr impurity to substitute into the LiAlO_2 lattice in the form of Cr^{4+} , a defect must be created for charge compensation. Consequently, any appreciable level of Cr doping in the crystal resulted in a large density of defects that made the waveguiding unacceptably lossy.

In order to confirm the feasibility of using evanescent wave coupling from a dielectric waveguide structure into an active substrate medium, similar single mode waveguides as described in the above were fabricated on a slab of Nd:SFAP substrate. Figure 8 the optical gain of the guided $1.3\mu\text{m}$ signal as a function of the pump intensity.

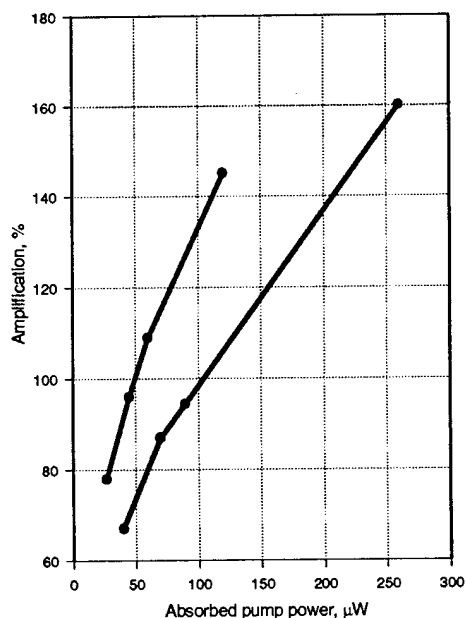

Fig. 8. Optical gain of the guided $1.3\mu\text{m}$ signal

CONCLUSIONS:

1. $\text{Cr}^{4+}:\text{LiAlO}_2$ is a useful material for providing broadband optical gain in the $1.3\mu\text{m}$ wavelength communications band. However, in order for the chromium impurity to be imbedded in the substitutional sites the charge compensation requirements result in a lattice defect being created. Co-doping with other impurities such as beryllium to accommodate the charge compensation without the creation of lattice defect was attempted. Unfortunately, the outcome of that experiment was not very successful in that a fairly large density of defects were still needed in order to dope the crystal to moderate concentrations of chromium.
2. We have investigated the use of thin film dielectric waveguides fabricated directly on top active substrates in order to extract optical gain from the substrate material via evanescent field coupling. The results are summarized as follows:
 - a. Silicon oxynitride waveguides have been fabricated initially on undoped LiAlO_2 substrates to assess the guiding properties. Full control of the refractive index of the films was achieved by controlling the ratio of the gas flows during the PECVD process. This allows for the accurate tailoring of the mode profile of the waveguide for good overlap integral with the substrate material.
 - b. Thin film silicon oxynitride waveguides have been fabricated on $\text{Cr}^{4+}:\text{LiAlO}_2$ substrates and optical gain of $1.3\mu\text{m}$ light have been measured.
 - c. Thin film silicon oxynitride waveguides have also been fabricated on $\text{Nd}:\text{SFAP}$ substrates and optical gain of $1.3\mu\text{m}$ light have been measured.
3. We have also characterized another chromium doped crystal $\text{Cr}^{4+}:\text{Ca}_2\text{GeO}_4$ (cunyite) as the alternative material for providing broadband optical gain at $1.3\mu\text{m}$. Other researchers have already reported the lasing property of that crystal. This material holds great promise for the realization of broadband integrated optical amplifiers for the $1.3\mu\text{m}$ telecommunications band.