

20010501 096

FINAL REPORT
JANUARY 2001

REPORT NO. 00-07

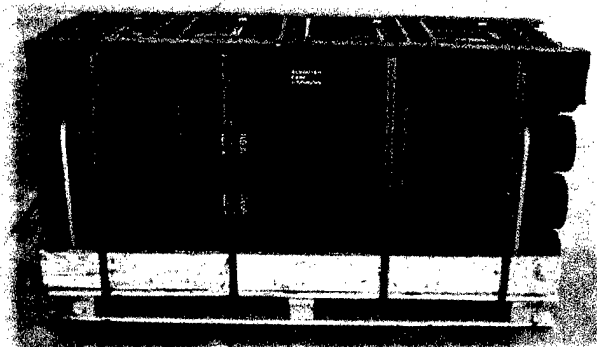

**2.75-INCH TRAINING ROCKET, PA150
CONTAINERS ON WOODEN PALLETS WITH
METAL TOP LIFT, MIL-STD-1660
FIRST ARTICLE TEST (FAT)**

Prepared for:
U.S. Army Armament Research, Development
and Engineering Center
ATTN: AMSTA-AR-WEP-RP
Rock Island, IL 61299-7300

Distribution Unlimited



**VALIDATION ENGINEERING DIVISION
MCALESTER, OKLAHOMA 74501-9053**

DISTRIBUTION STATEMENT A
Approved for Public Release
Distribution Unlimited

AVAILABILTY NOTICE

A copy of this report will be furnished each attendee on automatic distribution. Additional copies or authority for reprinting may be obtained by written request from:

Director
U.S. Army Defense Ammunition Center
ATTN: SMAAC-DEV
1 C Tree Road, Bldg. 35
McAlester, OK 74501-9053

Reports may also be downloaded or viewed in PDF format from our web site at:

<http://www.dac.army.mil/DEV/TestReports>

DISTRIBUTION INSTRUCTIONS

Destroy this report when no longer needed. Do not return.

Citation of trade names in this report does not constitute an official endorsement.

The information contained herein will not be used for advertising purposes.

**REPORT NO. 00-07
2.75-INCH TRAINING ROCKET, PA150 CONTAINERS
ON WOODEN PALLETS WITH METAL TOP LIFT
MIL-STD-1660, FIRST ARTICLE TEST (FAT)**

January 2001

ABSTRACT

The U.S. Army Defense Ammunition Center (DAC), Validation Engineering Division (SMAAC-DEV), was tasked by the U.S. Army Armament Research, Development and Engineering Center (ARDEC) to conduct a First Article Test (FAT) per MIL-STD-1660, "Design Criteria for Ammunition Unit Loads" on the 2.75-Inch Training Rocket, PA150 Containers on Wooden Pallets With Metal Top Lift. Three pallets were evaluated using MIL-STD-1660 test requirements. Significant flaws were found in Pallet 1 and Pallet 2 during testing. After alteration, Pallet 3 passed all requirements. As a result of the performance of the last pallet during testing, the 2.75-Inch Training Rocket, PA150 Containers on Wooden Pallets With Metal Top Lift is recommended for U.S. Army-wide use worldwide.

Prepared by:

Reviewed by:

JEFFREY L. DUGAN
Validation Engineer

JERRY W. BEAVER
Chief, Validation Engineering Division

U.S. ARMY DEFENSE AMMUNITION CENTER

VALIDATION ENGINEERING DIVISION
MCALESTER, OK 74501-9053

REPORT NO. 00-07

**2.75 -INCH TRAINING ROCKET, PA150 CONTAINERS ON
WOODEN PALLETS WITH METAL TOP LIFT
MIL-STD-1660 FIRST ARTICLE TEST (FAT)**

TABLE OF CONTENTS

PART	PAGE NO.
1. INTRODUCTION	1-1
A. BACKGROUND.....	1-1
B. AUTHORITY.....	1-1
C. OBJECTIVE	1-1
D. CONCLUSION	1-1
2. ATTENDEES	2-1
3. TEST PROCEDURES	3-1
4. TEST EQUIPMENT	4-1
5. TEST RESULTS	5-1
6. DRAWINGS.....	6-1

PART 1 – INTRODUCTION

A. BACKGROUND. The U.S. Army Defense Ammunition Center (DAC), Validation Engineering Division (SMAAC-DEV), was tasked by the U.S. Army Armament Research, Development and Engineering Center (ARDEC) to conduct First Article Test (FAT) per MIL-STD-1660 tests, "Design Criteria for Ammunition Unit Loads," on the 2.75-Inch Training Rocket, PA150 Containers on Wooden Pallets with Metal Top Lift. The unitization procedures were provided by the Defense Ammunition Center, Transportation Engineering Division (SMAAC-DET).

B. AUTHORITY. This test was conducted IAW mission responsibilities delegated by the U.S. Army Operations Support Command, Rock Island, IL. Reference is made to the following:

1. Change 6, AR 740-1, 18 August 1976, Storage and Supply Activity Operation.
2. IOC-R, 10-23, Mission and Major Functions of USADAC, 7 January 1998.

C. OBJECTIVE. The objective of the tests was to determine if the wooden pallet with a metal top lift adapter met MIL-STD-1660 test requirements prior to the acceptance of the unitization procedures by the U.S. Army.

D. CONCLUSION. Three pallets were evaluated using MIL-STD-1660 test requirements on separate dates. The first pallet was unstable due to a side-to-side rocking motion. The second pallet was altered and retested. The second test pallet still had excessive side-to-side rocking and a third pallet was re-altered and retested. No significant flaws were found in the last pallet during testing. As a result of the performance of the pallet during the last test, the 2.75-Inch Training Rocket, PA150 Containers on Wooden Pallets with Metal Top Lift is recommended for U.S. Army-wide use worldwide.

PART 2 - ATTENDEES

DATES PERFORMED:

Pallet 1: 1-2 August 2000

Pallet 2: 5-7 November 2000

Pallet 3: 19-20 December 2000

ATTENDEE

Jeffery L. Dugan
General Engineer
DSN 956-8090
(918) 420-8090

Mark Rehmstedt
Packaging Specialist
DSN 793-8206
(309) 782-8206

MAILING ADDRESS

Director
U.S. Army Defense Ammunition Center
ATTN: SMAAC-DEV
1 C Tree Road, Bldg. 35
McAlester, OK 74501-9053

Commander
U.S. Army Armament Research,
Development and Engineering Center
ATTN: AMSTA-AR-WEP-RP
Rock Island, IL 61299-7300

PART 3 - TEST PROCEDURES

The test procedures outlined in this section were extracted from the MIL-STD-1660, "Design Criteria for Ammunition Unit Loads," 8 April 1977. This standard identifies steps that a unitized load must undergo if it is to be considered acceptable. The six tests that were conducted on the test pallets are summarized below.

A. STACKING TEST. The unit load was tested to simulate a stack of identical unit loads stacked 16 feet high, for a period of one hour. This stacking load was simulated by subjecting the unit load to a compression weight equal to an equivalent 16-foot stacking height. The compression load was calculated in the following manner. The unit load weight was divided by the unit load height in inches and multiplied by 192. The resulting number was the equivalent compressive force of a 16-foot-high load. Figure 1 below shows an example of a unit load in the compression tester.

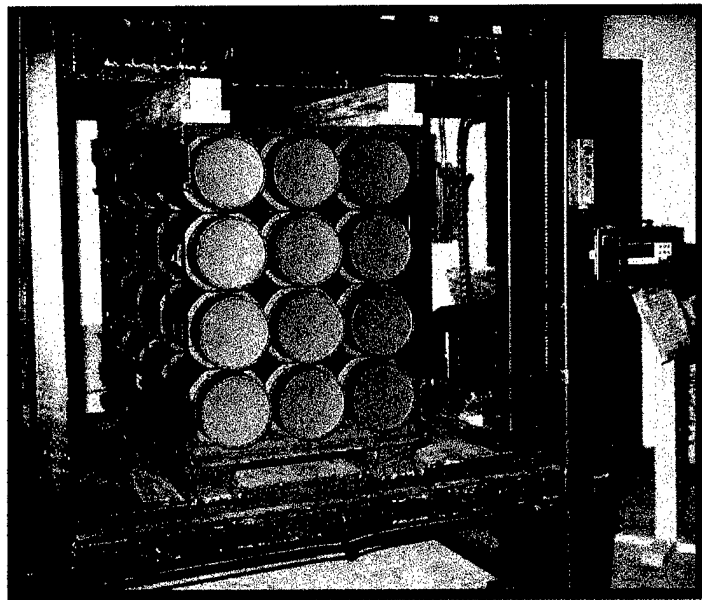

**Figure 1. Example of Compression Tester.
(2.75-inch Hydra 70, PA151 Rocket Pallet in the compression tester.)**

B. REPETITIVE SHOCK TEST. The repetitive shock test was conducted IAW Method 5019, Federal Standard 101. The test procedure is as follows: The test specimen was placed on (not fastened to) the platform. With the specimen in one position, the platform was vibrated at 1/2-inch amplitude (1-inch double amplitude) starting at a frequency of approximately 3 cycles-per-second. The frequency was steadily increased until the package left the platform. The resonant frequency was achieved when a 1/16-inch-thick feeler gage momentarily slid freely between every point on the specimen in contact with the platform at some instance during the cycle. Midway into the testing period, the specimen was rotated 90 degrees, and the test continued for the duration. Unless failure occurred, the total time of vibration was three hours. Figure 2 shows an example of the repetitive shock test.

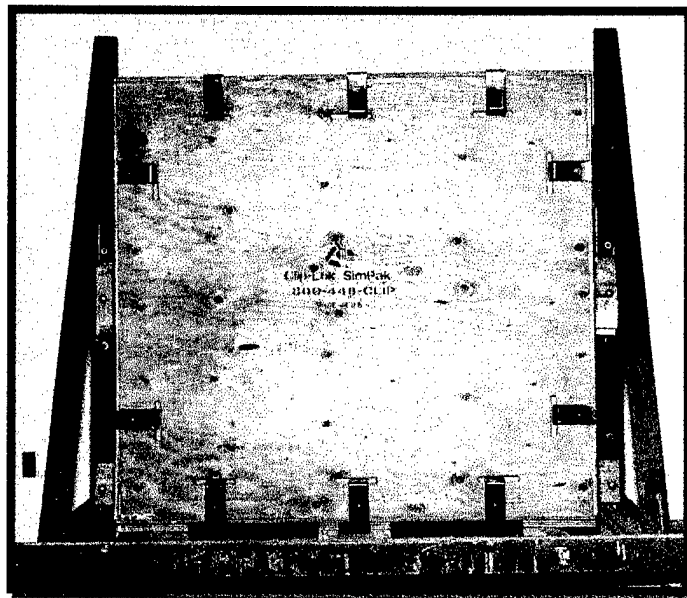
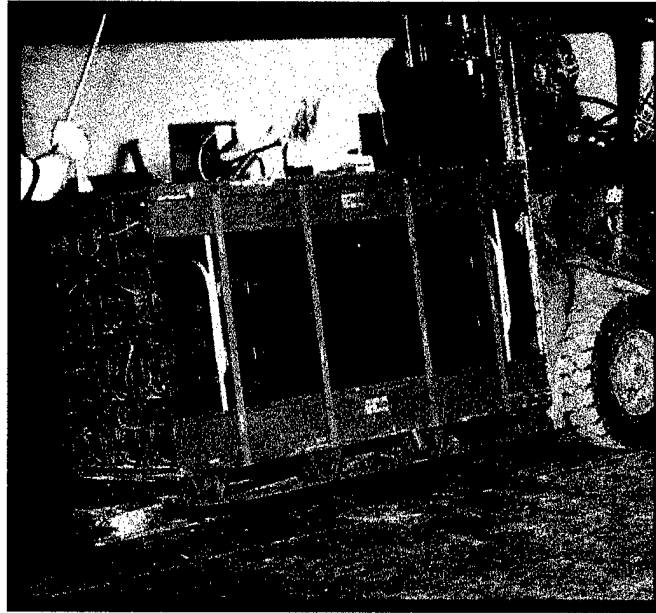

Figure 2. Example of the Repetitive Shock Test.
(**"Clip-Lok" pallet on the vibration table.**)

C. EDGEWISE ROTATIONAL DROP TEST. This test was conducted using the procedures of Method 5008, Federal Standard 101. The procedure for the edgewise rotational drop test is as follows: The specimen was placed on its skids with one end of the pallet supported on a beam 6 inches high. The height of the beam was increased if necessary to ensure that there was no support for the skids between the ends of the pallet when dropping took place, but was not high enough to cause the pallet to slide on the supports when the dropped end was raised for the drops. The unsupported end of the pallet was then raised and allowed to fall freely to the concrete, pavement, or similar underlying surface from a prescribed height. Unless otherwise specified, the height of drop for level A protection conforms to the following tabulation:

GROSS WEIGHT (WITHIN RANGE LIMITS) (Pounds)	DIMENSIONS OF ANY EDGE, HEIGHT OR WIDTH (WITHIN RANGE LIMITS) (Inches)	HEIGHT OF DROPS ON EDGES	
		Level A (Inches)	Level B (Inches)
150-250	60-66	36	27
250-400	66-72	32	24
400-600	72-80	28	21
600-1,000	80-95	24	18
1,000-1,500	95-114	20	16
1,500-2,000	114-144	17	14
2,000-3,000	Above 145- No limited	15	12
Above – 3,000		12	9



**Figure 3. Example of Edgewise Rotational Drop Test
(2.75-inch Hydra 70, PA151 Rocket Pallet)**

D. INCLINE-IMPACT TEST. This test was conducted by using the procedure of Method 5023, Incline-Impact Test of Federal Standard 101. The procedure for the incline-impact test is as follows: The specimen was placed on the carriage with the surface or edge to be impacted projecting at least 2 inches beyond the front end of the carriage. The carriage was brought to a predetermined position on the incline and released. If it were desired to concentrate the impact on any particular position on the container, a 4- x 4-inch timber would be attached to the bumper in the desired position before the test. The carriage struck no part of the timber. The position of the container on the carriage and the sequence in which surfaces and edges were subjected to impacts was at the option of the testing activity and depended upon the objective of the test. This test was to determine satisfactory requirements for a container or pack, and, unless otherwise specified, the specimen was subjected to one impact on each surface that has each dimension less than 9.5 feet. Unless otherwise specified, the velocity at

the time of the impact was 7 feet-per-second. Figure 4 shows an example of this test.

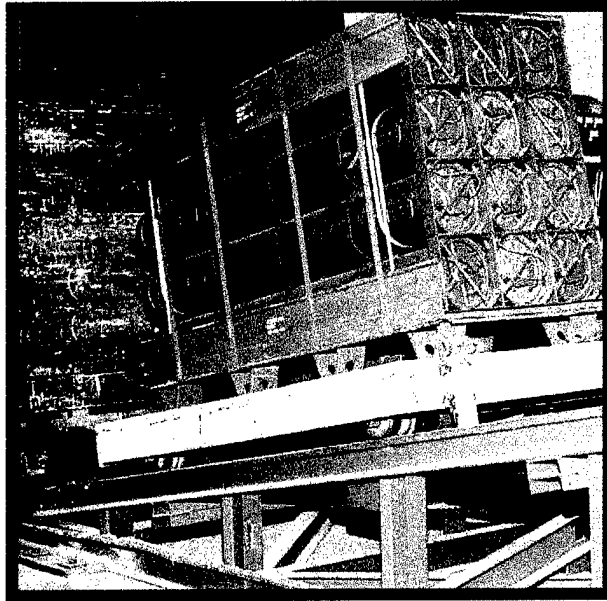

**Figure 4. Example of the Incline-Impact Test.
(2.75-Inch, Hydra 70, PA151 Rocket Pallet on
Incline-Impact Tester.)**

E. SLING COMPATIBILITY TEST. Unit loads utilizing special design or non-standard pallets shall be lifted, swung, lowered and otherwise handled as necessary, using slings of the types normally used for handling the unit loads under consideration. Slings shall be easily attached and removed. Danger of slippage or disengagement when load is suspended shall be cause for rejection of the unit load.

F. DISASSEMBLY TEST. Following all rough handling tests the unit load may be squared up within 2 inches of its original shape and on a flat level surface. The strapping shall then be cut and removed from the palletized load. Assembly of the load shall be such that it retains its unity upon removal of the strapping.

PART 4 - TEST EQUIPMENT

A. COMPRESSION TESTER.

- | | |
|-----------------------|----------------------|
| 1. Manufacturer: | Ormond Manufacturing |
| 2. Platform: | 60- by 60-inches |
| 3. Compression Limit: | 50,000 pounds |
| 4. Tension Limit: | 50,000 pounds |

B. TRANSPORTATION SIMULATOR.

- | | |
|------------------|---------------------|
| 1. Manufacturer: | Gaynes Laboratory |
| 2. Capacity: | 6,000-pound payload |
| 3. Displacement: | 1/2-inch amplitude |
| 4. Speed: | 50 to 400 RPM |
| 5. Platform: | 5- by 8-foot |

C. INCLINED PLANE.

- | | |
|------------------|--------------------|
| 1. Manufacturer: | Conbur Incline |
| 2. Type: | Impact Tester |
| 3. Grade: | 10 percent incline |
| 4. Length: | 12-foot |

PART 5 - TEST RESULTS

A. PALLET DATA. Each of the three pallets were inertly loaded to the specified design weight using two 4- x 4-inch lengths of lumber, two 2- x 4-inch lengths of lumber, and a quantity of ammunition simulant to bring each container individually to the required weight. Special care was taken to ensure that each container had the proper amount of weight in order to achieve a realistic pallet center of gravity (CG). Once properly prepared, the pallets were tested using MIL-STD-1660, "Design Criteria for Ammunition Unit Loads," requirements.

PALLET 1:

Date: 1-2 August 2000
Weight: 2,250 pounds
Length: 78-1/2 inches
Width: 29-5/16 inches
Height: 43-1/2 inches

PALLET 2:

Date: 5-7 November 2000
Weight: 2,250 pounds
Length: 78-1/2 inches
Width: 29-5/16 inches
Height: 43-1/2 inches

PALLET 3:

Date: 19-20 December 2000
Weight: 2,250 pounds
Length: 78-1/2 inches
Width: 29-5/16 inches
Height: 43-1/2 inches

B. PALLET 1 - TEST RESULTS:

1. **Compression Test.** Test Pallet 1 was compressed with a load force of 9,900 pounds for 90 minutes on 1 August 2000. No damage was noted as a result of this test. See figure 5 below for a typical picture of the test pallet in the compression unit.

2. **Repetitive Shock Test.** Test Pallet 1 was vibrated 90 minutes at 186 RPM in the longitudinal orientation and 90 minutes at 192 RPM in the lateral orientation. No damage was noted as a result of this test.

3. **Edgewise Rotational Drop Test.** Test Pallet 1 was edgewise rotationally dropped from a height of 15 inches on the longitudinal and 15 inches on the lateral drops. The last 5" inches of the middle board on the bottom of the pallet broke off during a drop. This was deemed minor and the drops were continued. No other problems were encountered.

4. **Incline-Impact Test.** The test pallet was incline-impacted on all four sides with the pallet impacting the stationary wall from a distance of 8 feet. Again, no problems were encountered.

5. **Sling Compatibility Test.** The test pallet was lifted off of the ground using the top lift adapter by four points, three points, two diagonal points, and two adjacent points. No shifting of the containers or permanent deformation of the top lift adapter was noted.

6. **Disassembly Test.** Before the disassembly test, it was noted that the pallet had a side-to-side rocking motion; this motion was due to the pallet bowing up on the outside edges of the pallet when the steel banding was tightened. This issue was discussed with the designer, and it was decided to change the bottom deck boards from 1 x 4 to 1 x 6 boards. Following completion of MIL-STD-1660

testing, the pallet was disassembled and inspected for damage. Minor wood cracks were noted on the side boards. Three nails had pulled up ¼" on the bottom deck. No significant damage was noted.

7. **Conclusion.** The pallet met MIL-STD-1660, "Design Criteria for Ammunition Unit Loads" with no major problems noted; however, the pallet will be retested with the wider deck boards that were changed to eliminate the side-to-side rocking.

C. **PALLET 2 - TEST RESULTS:**

1. **Compression Test.** Test Pallet 2 was compressed with a load force of 9,900 pounds for 90 minutes on 5 November 2000. No damage was noted as a result of this test. See figure 5 below for a typical picture of the test pallet in the compression unit.

2. **Repetitive Shock Test.** Test Pallet 2 was vibrated 90 minutes at 200 RPM in the longitudinal orientation and at 90 minutes at 240 RPM in the lateral orientation. No damage was noted as a result of this test.

3. **Edgewise Rotational Drop Test.** Test Pallet 2 was edgewise rotationally dropped from a height of 15 inches on the longitudinal and 15 inches on the lateral drops. The last 4" inches of the middle board on the bottom of the pallet broke off during a drop. This was deemed minor and the drops were continued. No other problems were encountered.

4. **Incline-Impact Test.** The test pallet was incline-impacted on all four sides with the pallet impacting the stationary wall from a distance of 8 feet. Again, no problems were encountered.

5. **Sling Compatibility Test.** The test pallet was lifted off of the ground using the top lift adapter by four points, three points, two diagonal points, and two adjacent points. No shifting of the containers or permanent deformation of the top lift adapter was noted.

6. **Disassembly Test.** Before disassembly test it, was noted that the pallet had a side-to-side rocking motion even after increasing the width of the deck boards. This issue was discussed with the designer, and it was decided to change the stringer boards to 1 x 12 to strengthen the pallet, this change along with using the 1 x 6 deck boards would help eliminate the rocking. Following completion of MIL-STD-1660 testing, the pallet was disassembled and inspected for damage. Minor wood cracks were noted on the side boards. No significant damage was noted.

7. **Conclusion.** The pallet met MIL-STD-1660, "Design Criteria for Ammunition Unit Loads," with no major problems noted; however, the pallet will be retested with the wider stringer boards and deck boards that were changed to strengthen the pallet to eliminate the side-to-side rocking.

D. PALLET 3 - TEST RESULTS:

1. Compression Test. Test Pallet 3 was compressed with a load force of 9,900 pounds for 90 minutes on 19 December 2000. No damage was noted as a result of this test. See Figure 5 for Test Pallet 3 in compression.

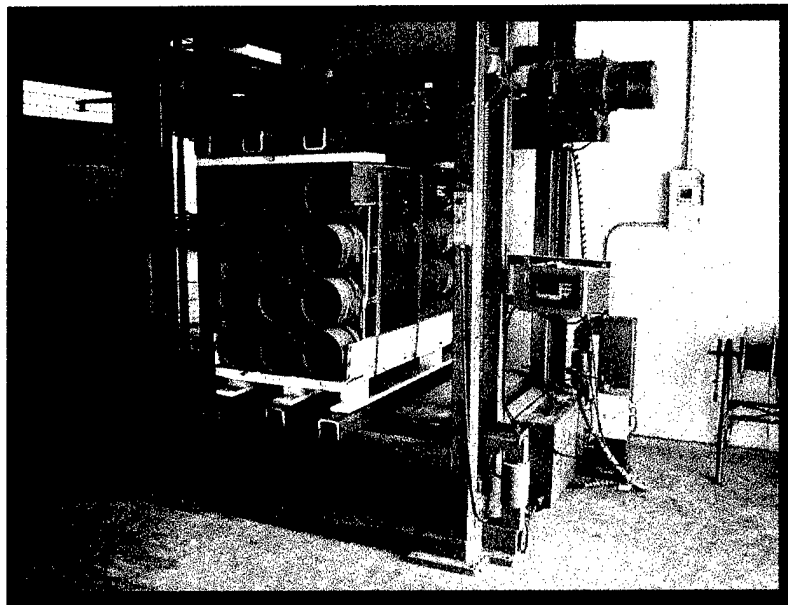

Figure 5. 2.75 -Inch Training Rocket, PA150 Container on Wooden Pallets with Metal Top Lift, Test Pallet 3 on the Compression Tester.

2. **Repetitive Shock Test.** Test Pallet 3 was vibrated 90 minutes at 135 RPM in the longitudinal orientation and 90 minutes at 215 RPM in the lateral orientation. No damage was noted as a result of this test. See Figure 6 below.

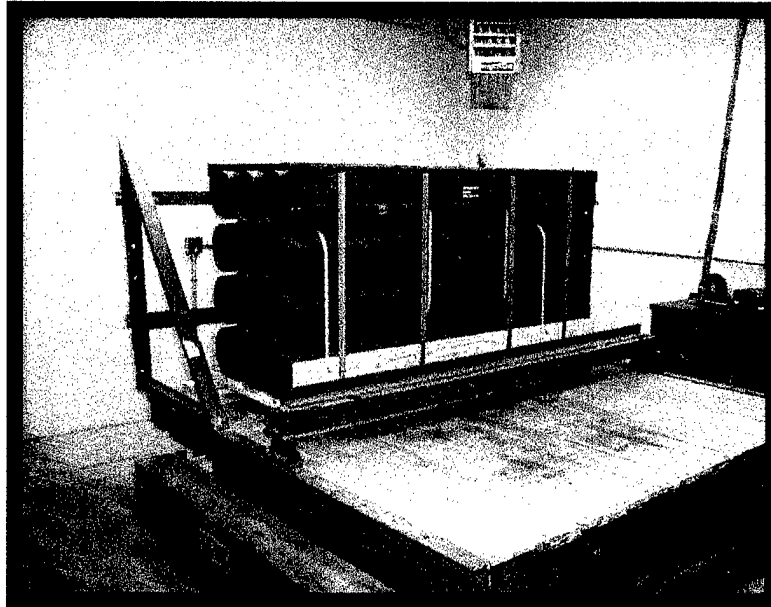

Figure 6. 2.75 –Inch Training Rocket, PA150 Container on Wooden Pallets with Metal Top Lift, Test Pallet 3 on the Vibration Table.

3. **Edgewise Rotational Drop Test.** Test Pallet 3 was edgewise rotationally dropped from a height of 15 inches on the longitudinal and 15 inches on the lateral drops. Minor board splitting in the bottom pallet boards was noted. No other problems were encountered. See Figure 7 for the drop test setup.

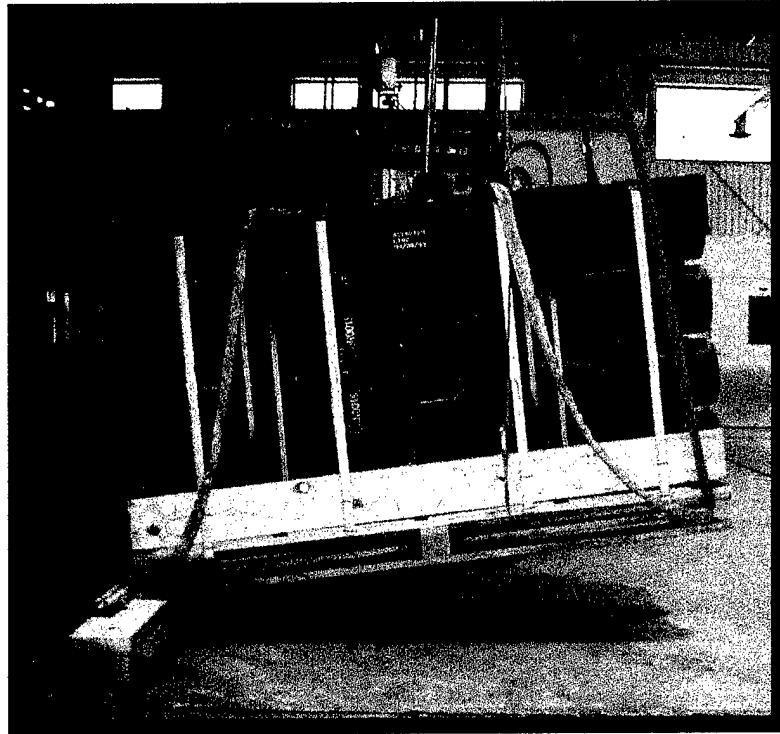

Figure 7. 2.75 -Inch Training Rocket, PA150 Container on Wooden Pallets with Metal Top Lift, Test Pallet 3 During Edgewise Drop Tests

4. Incline-Impact Test. Test Pallet 3 was incline-impacted on all four sides with the pallet impacting the stationary wall from a distance of 8 feet. Again, no problems were encountered.

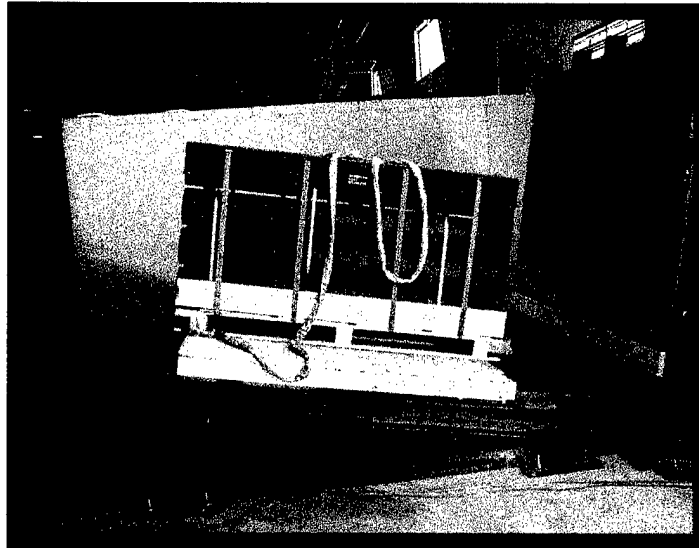

Figure 8. 2.75 –Inch Training Rocket, PA150 Container on Wooden Pallets with Metal Top Lift, Test Pallet 3 During Inclined Impact Tests

5. Sling Compatibility Test. Test Pallet 3 was lifted off of the ground using the top lift adapter by four points, three points, two diagonal points, and two adjacent points. No shifting of the containers or permanent deformation of the top lift adapter was noted.

6. Disassembly Test. Following completion of MIL-STD-1660 testing, Pallet 3 was disassembled and inspected for damage. The rocking side-to-side was greatly reduced to less than 1/8". No additional damage was noted.

7. **Conclusion.** Test Pallet 3 met MIL-STD-1660, "Design Criteria for Ammunition Unit Loads," with no major problems noted and is recommended for U.S. Army-wide use worldwide.

PART 6- DRAWINGS

The following drawing (Test Procedures - #2) represents the load configuration that was subjected to the test criteria. The final load drawing for the 2.75-Inch Hydra on wooden pallet will be AMC Drawing # 19-48-4326/60-20PM1012. Upon final approval this drawing may be located at:

<http://www.dac.army.mil/DET/dapam/toc.html>

TEST PROCEDURES - #2

UNITIZATION PROCEDURES^o FOR MIL-STD 1660 TESTING OF ROCKET, 2.75" HYDRA, PACKED 4 PER PA150 CYLINDRICAL METAL CONTAINER ON 4-WAY ENTRY WOODEN PALLETS WITH METAL TOP LIFT

NOTICE: THIS DRAWING CANNOT STAND ALONE BUT MUST BE USED IN CONJUNCTION WITH THE BASIC UNITIZATION PROCEDURES DRAWING 19-48-4326-20PM1001. PAGE 2 HAS BEEN INTENTIONALLY OMITTED.

Prepared during November 2000 by:
U.S. Army Defense Ammunition Center
ATTN: SMAAC-DET
McAlester, OK 74501
POC: Ms. Laura A. Fleffer
DSN 956-8072/8927
Comm (918) 420-8072/8927
Fax 956-8811
E-mail: fleffer@dac-erh2.army.mil

//signed//
William R. Frerichs
Chief, Transportation Engineering Division

PROJECT _____

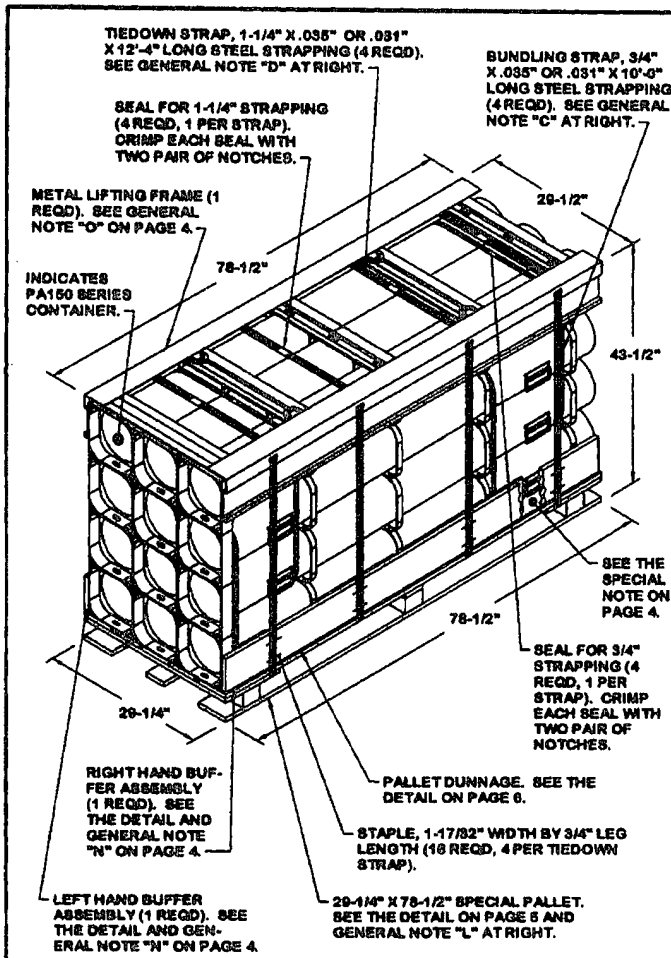

PALLET UNIT

SEE GENERAL NOTE "B" AT RIGHT.

12 CONTAINERS OF ROCKETS (4 PER CNTR) @ 162 LBS	- - - - -	1,944 LBS (APPROX)
DUNNAGE	- - - - -	133 LBS
PALLET	- - - - -	85 LBS
TOTAL WEIGHT	- - - - -	2,162 LBS (APPROX)
CUBE	- - - - -	58.3 CU FT (APPROX)

BILL OF MATERIAL		
NAILS	NO. REQD	POUNDS
6d (2")	48	0.28
SPECIAL PALLET	1 REQD	85 LBS
STEEL STRAPPING, 3/4"	40.00 REQD	3.57 LBS
SEAL FOR 3/4" STRAPPING	4 REQD	NIL
STEEL STRAPPING, 1-1/4"	49.33 REQD	7.47 LBS
SEAL FOR 1-1/4" STRAPPING	4 REQD	NIL
PLYWOOD, 3/8"	16.92 SQ FT REQD	17.45 LBS
PLYWOOD, 3/4"	6.50 SQ FT REQD	13.41 LBS
STRAP STAPLE, 1-17/32" X 3/4"	16 REQD	NIL
METAL LIFTING FRAME	1 REQD	90 LBS

GENERAL NOTES

- A. THIS APPENDIX CANNOT STAND ALONE BUT MUST BE USED IN CONJUNCTION WITH THE BASIC UNITIZATION PROCEDURES DRAWING 19-48-4329-20PM1012. TO PRODUCE AN APPROVED UNIT LOAD, ALL PERTINENT PROCEDURES, SPECIFICATIONS AND CRITERIA SET FORTH WITHIN THE BASIC DRAWING WILL APPLY TO THE PROCEDURES DELINEATED IN THIS APPENDIX. ANY EXCEPTIONS TO THE BASIC PROCEDURES ARE SPECIFIED IN THIS APPENDIX.
- B. DIMENSIONS, CUBE AND WEIGHT OF A PALLET UNIT WILL VARY SLIGHTLY DEPENDING UPON THE ACTUAL DIMENSIONS OF THE CONTAINERS AND THE WEIGHT OF THE SPECIFIC ITEM BEING UNITIZED.
- C. BUNDLING STRAPS MUST BE TENSIONED AND SEALED PRIOR TO THE APPLICATION OF THE TIEDOWN STRAPS. BUNDLING STRAPS MUST ALSO BE INSTALLED AS CLOSE TO THE OUTER RINGS AS POSSIBLE, TO AVOID DAMAGE TO THE CONTAINER HANDLES.
- D. INSTALL EACH TIEDOWN STRAP TO PASS UNDER THE DECK/TRINGER BOARDS OF THE PALLET AND TO BE LOCATED AS SHOWN. TIEDOWN STRAPS WILL NOT BE APPLIED UNTIL THE BUNDLING STRAPS HAVE BEEN TENSIONED AND SEALED.
- E. ALTHOUGH THE CONTAINERS DEPICTED IN THE UNIT LOAD AT LEFT ARE CONSTRUCTED WITH INTERLOCKING DEVICES, THE INTERLOCKS WILL NOT FUNCTION PROPERLY UNLESS THE CONTAINERS ARE POSITIONED SO THAT THE "PINS" OF THE INTERLOCKS ARE FACING UPWARD. THIS ORIENTATION WILL AID IN THE PREVENTION OF CONTAINER MOVEMENT, BOTH LATERALLY AND LONGITUDINALLY, DURING SHIPMENT OF THE UNIT LOAD.
- F. THE FOLLOWING AMC DRAWINGS ARE APPLICABLE FOR OUTLOADING AND STORAGE OF THE ITEMS COVERED BY THIS APPENDIX.

CARLOADING	- - - - -	19-48-4330/60-5PM1007
TRUCKLOADING	- - - - -	19-48-4331/60-11PM1007
STORAGE	- - - - -	19-48-4335/60-1-3-4-14-22PM1007
END OPENING ISO CONTAINER	- - - - -	19-48-4333/60-15PM1024
MILVAN	- - - - -	19-48-4332/60-15PM1023
SIDE OPENING ISO CONTAINER	- - - - -	19-48-4334/60-15PM1025
- G. IF ITEMS COVERED HEREIN ARE UNITIZED PRIOR TO ISSUANCE OF THIS APPENDIX, THE CONTAINERS NEED NOT BE REUNITIZED SOLELY TO CONFORM TO THIS APPENDIX.
- H. CONVERSION TO METRIC EQUIVALENTS: DIMENSIONS WITHIN THIS DOCUMENT ARE EXPRESSED IN INCHES, AND WEIGHTS ARE EXPRESSED IN POUNDS. WHEN NECESSARY, THE METRIC EQUIVALENTS MAY BE COMPUTED ON THE BASIS OF ONE INCH EQUALS 25.4MM AND ONE POUND EQUALS 0.454 KG.
- J. THE UNITIZATION PROCEDURES DEPICTED HEREIN MAY ALSO BE USED FOR UNITIZING 2.75" HYDRA ROCKETS WHEN IDENTIFIED BY DIFFERENT NATIONAL STOCK NUMBERS (NSN) THAN WHAT IS SHOWN ON PAGE 2, PROVIDED THE CONTAINER PACK DOES NOT VARY FROM WHAT IS DELINEATED HEREIN. THE EXPLOSIVE CLASSIFICATION OF OTHER ITEMS MAY BE DIFFERENT THAN WHAT IS SHOWN.
- K. EMPTY OR REJECT PA150 CONTAINERS WILL BE USED AS FILLER CONTAINERS AS NECESSARY. FILLER CONTAINERS MUST BE INSTALLED IN THE MIDDLE OF THE TOP LAYER(S) OF CONTAINERS. IF THREE FULL CONTAINERS ARE TO BE OMITTED, ONE FULL LAYER OF CONTAINERS WILL BE OMITTED. WHEN (REJECTED) FILLER CONTAINERS ARE USED IN PLACE OF OMITTED CONTAINERS TO COMPLETE A LAYER ON A PALLET, THEY WILL BE MARKED AS SPECIFIED IN ARDEC DRAWING NO. 12882865.
- L. THE SPECIAL PALLET WILL BE CONSTRUCTED AND ASSEMBLED IN ACCORDANCE WITH A MILITARY SPECIFICATION MIL-P-18011, STYLE 1A, TYPE 1, CLASS 1, PRESERVATIVE TREATED PALLET AND THE DETAILS ON PAGE 6.
- M. ALL DUNNAGE SHALL BE PRESERVATIVE TREATED IN ACCORDANCE WITH GENERAL NOTE "X" IN THE BASIC PROCEDURE.

(CONTINUED ON PAGE 4)

(GENERAL NOTES CONTINUED)

- N. THE THICKNESS OF THE PLYWOOD BUFFER PIECES DEPICTED IN THE BUFFER ASSEMBLIES BELOW MUST BE ADJUSTED AS REQUIRED TO COMPLY WITH THE DIMENSIONAL VARIANCE OF THE PA150 CONTAINERS, SO AS TO COMPLETELY FILL OUT THE PALLET. NOTE: NOMINAL 1" X 6" MATERIAL MAY BE SUBSTITUTED FOR THE 3/8" THICK PLYWOOD IF IT WILL CAUSE THE PALLET UNIT DIMENSIONS TO BE EQUAL TO OR GREATER THAN 29-1/2". REDUCE THE THICKNESS OF THE 3/8" PLYWOOD FILL PIECES AS APPROPRIATE.
- O. FOR DETAILS OF THE TOP LIFT ASSEMBLY, SEE DAC DRAWING NO. ACV00647 AND MILITARY SPECIFICATION MIL-A-70768.
- P. WHEN ONE LAYER IS OMITTED FROM A PALLET UNIT, THE TWO BUNDLING STRAPS THAT SURROUND THE SECOND, THIRD, AND FOURTH LAYERS WILL BE OMITTED. THE REMAINING BUNDLING STRAPS WILL SURROUND THE FIRST THROUGH THIRD LAYERS. A UNIT WITH TWO LAYERS DOES NOT REQUIRE BUNDLING STRAPS.
- Q. DIMENSIONS GIVEN FOR DUNNAGE PIECES WILL BE FIELD CHECKED PRIOR TO THEIR ASSEMBLY IN THE PALLET UNIT. CONTAINERS MUST FIT TIGHTLY IN THE DUNNAGE ASSEMBLIES. ALSO, DUE TO THE VARIATION OF CONTAINER DIMENSIONS, ADJUSTMENTS MAY BE REQUIRED AS TO THE LOCATION OF CERTAIN PIECES OF DUNNAGE IN A DUNNAGE ASSEMBLY.
- R. FOR DETAILS OF THE PA150 SERIES CONTAINER SEE ARDEC DRAWING NO. 12637886-2.

SPECIAL NOTE:

CARE MUST BE TAKEN TO AVOID CONTACT BETWEEN THE FILL PIECES AND THE HANDLES ON THE PA150 CONTAINERS. ADJUST THE SIZE AND/OR LOCATION OF THE FILL PIECES AS NECESSARY TO AVOID CONTACT.

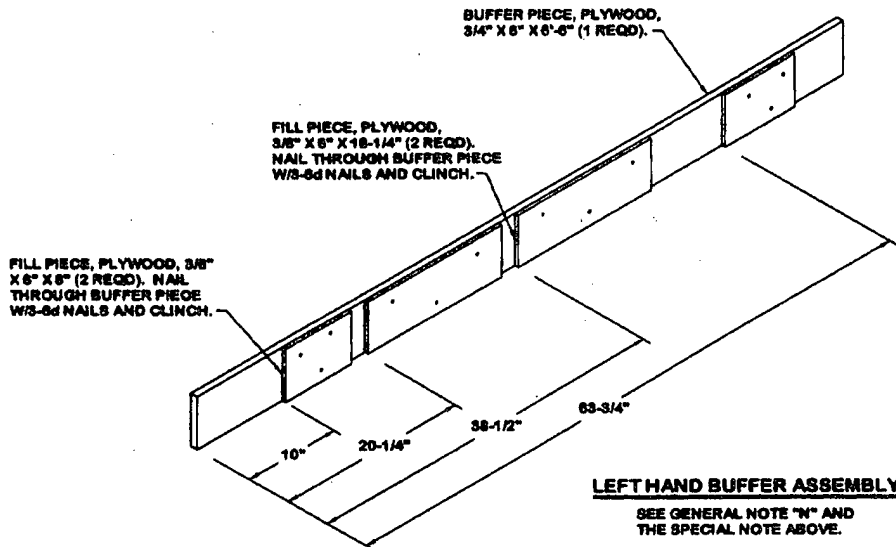
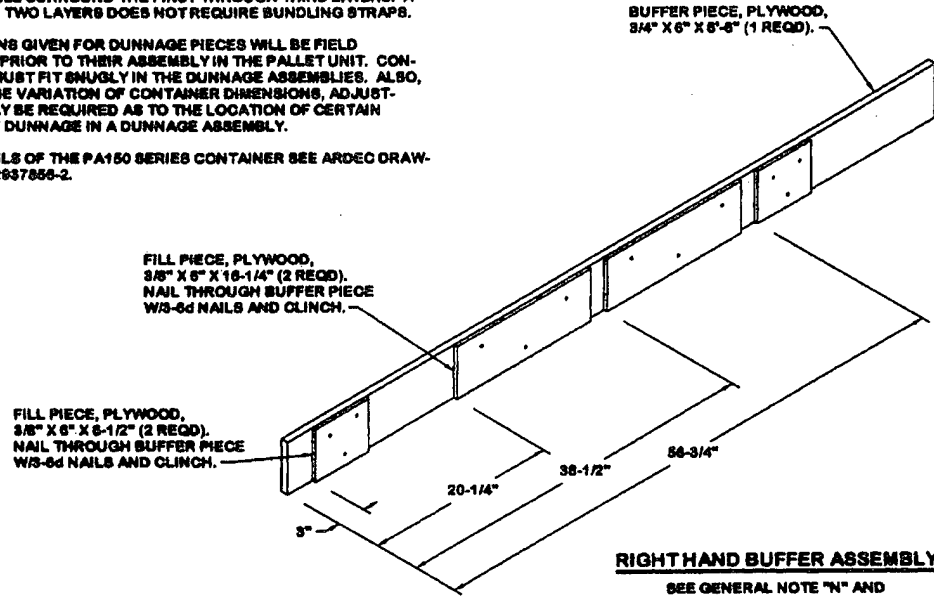

SPECIAL NOTE:

THE SPECIAL PALLET DEPICTED BELOW WILL BE CONSTRUCTED AND ASSEMBLED IN ACCORDANCE WITH A MILITARY SPECIFICATION MIL-P-15011, STYLE 1A, TYPE I, CLASS 1, PRESERVATIVE TREATED PALLET, EXCEPT FOR THE DIMENSION VARIANCES AND COMPONENT QUANTITIES SHOWN IN THE KEY LETTERS AND DETAIL BELOW. REFER TO MILITARY SPECIFICATION MIL-P-15011 FOR DETAILS AS TO MATERIAL SPECIFICATIONS, PRESERVATIVE TREATMENT, TOLERANCES, INSPECTION CRITERIA, ETC. NOTE THAT STRAPS SLOTS AND CHAMFERS ARE NOT REQUIRED FOR THE PALLET DEPICTED HEREIN.

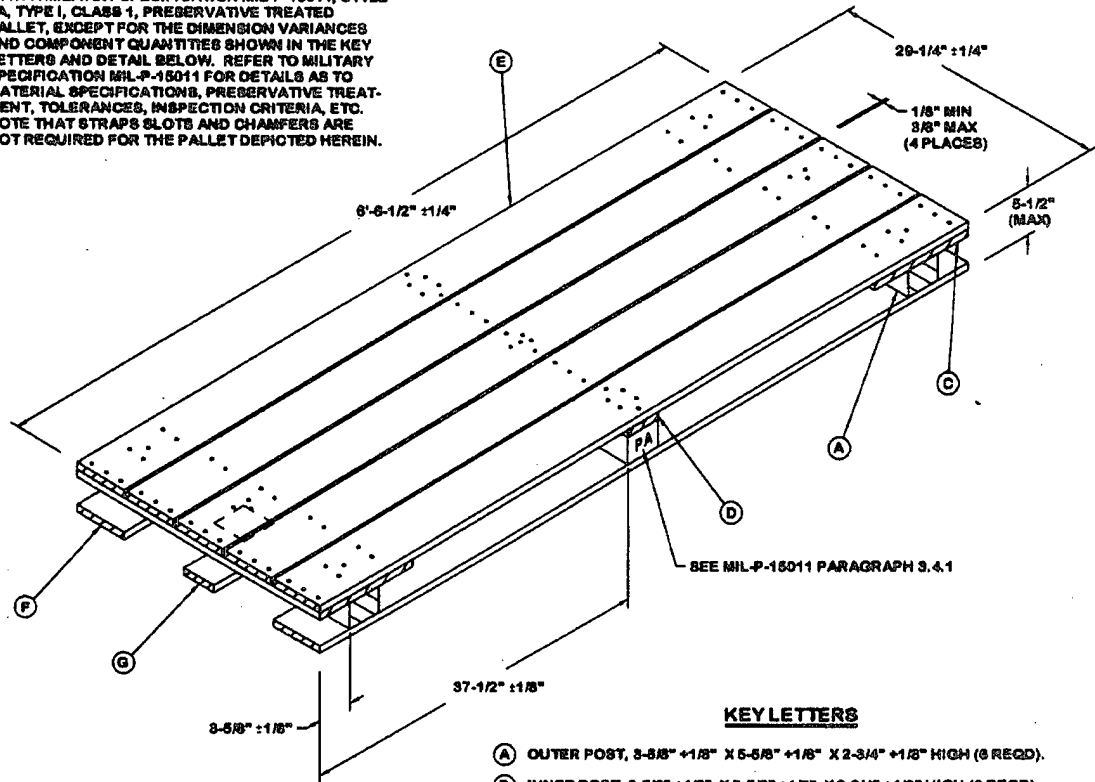

SPECIAL WOODEN PALLET DETAILS

KEY LETTERS

- (A) OUTER POST, 3-5/8" ± 1/8" X 5-5/8" ± 1/8" X 2-3/4" ± 1/8" HIGH (3 REQD).
- (B) INNER POST, 3-5/8" ± 1/8" X 3-5/8" ± 1/8" X 2-3/4" ± 1/8" HIGH (3 REQD).
- (C) OUTER STRINGER, 13/16" ± 1/16" X 11-1/4" ± 1/8" X 29-1/4" ± 1/8" (2 REQD).
- (D) INNER STRINGER, 13/16" ± 1/16" X 3-5/8" ± 1/8" X 29-1/4" ± 1/8" (1 REQD).
- (E) TOP DECK BOARD, 13/16" ± 1/16" X 5-5/8" ± 1/8" X 6'-6-1/2" ± 1/8" (5 REQD). NAIL ALL DECK BOARDS TO THE STRINGERS W/3 NAILS (1.5" LONG X 0.120" DIAMETER) AT EACH LOCATION. NAIL OUTSIDE AND CENTER DECK BOARDS THRU THE STRINGERS INTO THE POSTS W/3 NAILS (3.25" LONG X 0.135" DIAMETER) AT EACH LOCATION.
- (F) OUTER BOTTOM DECK BOARD, 13/16" ± 1/16" X 5-5/8" ± 1/8" X 6'-6-1/2" ± 1/8" (2 REQD). NAIL TO THE POSTS W/3 NAILS (2.25" LONG X 0.120" DIAMETER) AT EACH JOINT. SEE THE "OUTER BOTTOM DECK BOARD HOLE DETAIL" BELOW.
- (G) INNER BOTTOM DECK BOARD, 13/16" ± 1/16" X 3-5/8" ± 1/8" X 6'-6-1/2" ± 1/8" (1 REQD). NAIL TO THE POSTS W/3 NAILS (2.25" LONG X 0.120" DIAMETER) AT EACH JOINT.

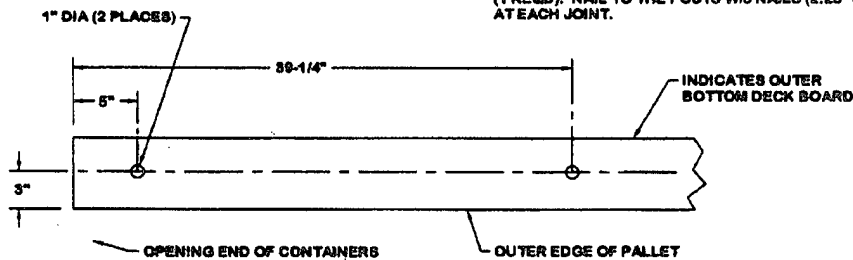

OUTER BOTTOM DECK BOARD HOLE DETAIL

THE DETAIL ABOVE SHOWS THE OUTER DECK BOARD ON THE RIGHT SIDE (FACING THE OPENING ENDS OF THE CONTAINERS) OF THE PALLET. THE OUTER DECK BOARD FOR THE LEFT SIDE OF THE PALLET WILL BE A MIRROR IMAGE (LOCATE THE HOLES 3" FROM THE OUTSIDE OF THE BOARD).

