

AD_____

Award Number: DAMD17-98-1-8015

TITLE: PAI-1 Gene as a Target for Breast Cancer Therapy

PRINCIPAL INVESTIGATOR: Paul Higgins, Ph.D.

CONTRACTING ORGANIZATION: Albany Medical College
Albany, New York 12208

REPORT DATE: April 2000

TYPE OF REPORT: Annual

PREPARED FOR: U.S. Army Medical Research and Materiel Command
Fort Detrick, Maryland 21702-5012

DISTRIBUTION STATEMENT: Approved for Public Release;
Distribution Unlimited

The views, opinions and/or findings contained in this report are those of the author(s) and should not be construed as an official Department of the Army position, policy or decision unless so designated by other documentation.

20010509 048

REPORT DOCUMENTATION PAGE

Form Approved
OMB No. 074-0188

Public reporting burden for this collection of information is estimated to average 1 hour per response, including the time for reviewing instructions, searching existing data sources, gathering and maintaining the data needed, and completing and reviewing this collection of information. Send comments regarding this burden estimate or any other aspect of this collection of information, including suggestions for reducing this burden to Washington Headquarters Services, Directorate for Information Operations and Reports, 1215 Jefferson Davis Highway, Suite 1204, Arlington, VA 22202-4302, and to the Office of Management and Budget, Paperwork Reduction Project (0704-0188), Washington, DC 20503

1. AGENCY USE ONLY (Leave blank)		2. REPORT DATE Arpil 2000	3. REPORT TYPE AND DATES COVERED Annual (1 Apr 99 - 31 Mar 00)	
4. TITLE AND SUBTITLE PAI-1 Gene as a Target for Breast Cancer Therapy			5. FUNDING NUMBERS DAMD17-98-1-8015	
6. AUTHOR(S) Paul Higgins, Ph.D.				
7. PERFORMING ORGANIZATION NAME(S) AND ADDRESS(ES) Albany Medical College Albany, New York 12208 E-MAIL: Higginp@mail.amc.edu			8. PERFORMING ORGANIZATION REPORT NUMBER	
9. SPONSORING / MONITORING AGENCY NAME(S) AND ADDRESS(ES) U.S. Army Medical Research and Materiel Command Fort Detrick, Maryland 21702-5012			10. SPONSORING / MONITORING AGENCY REPORT NUMBER	
11. SUPPLEMENTARY NOTES				
12a. DISTRIBUTION / AVAILABILITY STATEMENT Approved for public release; distribution unlimited				12b. DISTRIBUTION CODE
13. ABSTRACT (Maximum 200 Words) The purpose of work in year 02 of this study was to define the in vitro growth characteristics of stable lines of human breast carcinoma cells (developed in year 01) that expressed varying levels of plasminogen activator inhibitor type-1 (PAI-1) as a result of transfection with vectors bearing PAI-1 cDNA inserts cloned in the sense and antisense orientations. A panel of 18 such genetically-engineered epithelial cells was created. Eight of these cell lines were completely assessed as to their ability (1) to adhere to surfaces coated with various extracellular matrix proteins (adhesion assay), (2) to locomote across a planar surface following scrape-injury of a confluent monolayer (directed cell migration), and (3) to exhibit motile growth behavior in invasion chamber assays. PAI-1 expression was required for epithelial cell migration in directed assays since antisense targeting of PAI-1 transcripts reduced both cell adhesion and locomotion on extracellular matrices. A "window" level of PAI-1 expression was necessary for optimal epithelial cell locomotion and invasive migration. These data support the hypothesis that PAI-1 synthesis is necessary for invasive motility and metastatic behavior of human breast cancer cells. Work in year 03 will test this hypothesis in vivo.				
14. SUBJECT TERMS Breast Cancer			15. NUMBER OF PAGES 26	
			16. PRICE CODE	
17. SECURITY CLASSIFICATION OF REPORT Unclassified	18. SECURITY CLASSIFICATION OF THIS PAGE Unclassified	19. SECURITY CLASSIFICATION OF ABSTRACT Unclassified	20. LIMITATION OF ABSTRACT Unlimited	

FOREWORD

Opinions, interpretations, conclusions and recommendations are those of the author and are not necessarily endorsed by the U.S. Army.

PN X Where copyrighted material is quoted, permission has been obtained to use such material.

 Where material from documents designated for limited distribution is quoted, permission has been obtained to use the material.

 Citations of commercial organizations and trade names in this report do not constitute an official Department of Army endorsement or approval of the products or services of these organizations.

PN X In conducting research using animals, the investigator(s) adhered to the "Guide for the Care and Use of Laboratory Animals," prepared by the Committee on Care and use of Laboratory Animals of the Institute of Laboratory Resources, national Research Council (NIH Publication No. 86-23, Revised 1985).

 For the protection of human subjects, the investigator(s) adhered to policies of applicable Federal Law 45 CFR 46.

 In conducting research utilizing recombinant DNA technology, the investigator(s) adhered to current guidelines promulgated by the National Institutes of Health.

 In the conduct of research utilizing recombinant DNA, the investigator(s) adhered to the NIH Guidelines for Research Involving Recombinant DNA Molecules.

 In the conduct of research involving hazardous organisms, the investigator(s) adhered to the CDC-NIH Guide for Biosafety in Microbiological and Biomedical Laboratories.

Xiang J. Assou
PI - Signature

4/16/00
Date

Table of Contents

Front Cover.....	page 1
Report Documentation Page.....	page 2
Foreword.....	page 3
Table of Contents.....	page 4
Introduction.....	page 5
Body.....	page 6
Key Research Accomplishments.....	page 7
Reportable Outcomes.....	page 8
Conclusions.....	page 9
References.....	page 9
Appendix.....	page 11

Four (4) figures, one (1) table and one (1) reprint appended

Introduction

Cancer invasion and metastasis are complex processes in which controlled and focalized extracellular matrix (ECM) degradation facilitates cellular migratory activity. Matrix turnover is accomplished by the concerted action of several cascading proteolytic systems including the generation of plasmin by the urokinase (uPA)-dependent pathway of plasminogen activation (Dano et al., 1994; Andreasen et al., 1997). Plasmin, in turn, degrades the ECM directly as well as indirectly by activating latent metalloproteinases (Dano et al., 1987; Vaheri et al., 1990; Pollanen et al., 1991). Within this context, plasminogen activator inhibitor type-1 (PAI-1) plays a primary role as a negative regulator of this pericellular proteolytic cascade by complexing to and inhibiting the catalytic activity of uPA (Blasi et al., 1987; Andreasen et al., 1997). Studies in mice genetically engineered to be deficient in one or more elements in the plasmin activation cascade have confirmed the importance of uPA and plasmin in cell migration (Romer et al., 1996; Carmeliet et al., 1997). Cell type-specific synthesis and subcellular targeting of PAI-1 and uPA appear to be important considerations in modulation of the pericellular proteolytic balance. Temporal changes in the expression, focalization, and/or relative activity of this protease/inhibitor pair may influence cell migration either as a direct consequence of ECM barrier proteolysis or by modulating cellular adhesive interactions with the ECM (Ciambone and McKeown-Longo, 1990; Blasi, 1996, 1997; Carmeliet et al., 1997). This has direct relevance to outcomes in human breast cancer. Clinical studies have demonstrated that, in general, elevated tumor levels of uPA, the uPA receptor, and PAI-1 are conducive to tumor metastasis and associated with poor disease prognosis (Schmidt et al., 1992; Duffy, 1992, 1996; Pedersen et al., 1994). The role of PAI-1 as a determinant in aggressive growth behavior is particularly important in breast carcinoma (Costantini et al., 1996; Gandolfo et al., 1996; Mayerhofer et al., 1996; Fersis et al., 1996; Torre and Fulco, 1996; Foekens et al., 1995). The purpose of this work, therefore, is to utilize a molecular genetic approach to manipulate levels of PAI-1 expression in human breast carcinoma cells to (1) generate panels of genetically-engineered human breast cancer cells which vary in levels of PAI-1 expression/synthesis, (2) assess the *in vitro* growth characteristics of these cells, and (3) evaluate the usefulness of the PAI-1 gene as an *in vivo* therapeutic target. To do this, we have constructed vectors bearing a full-length PAI-1 cDNA; expression of this cDNA, cloned in both sense and antisense orientations, is under control of various, tandemly-linked, copies of myc-responsive E-box promoter sequences to take advantage of the endogenous breast cancer MYC protein as a means to regulate transcriptional strength. Such utilization of tumor-associated anomalies in transcription factor (i.e., MYC) expression to direct genetic-based intervention therapies is a new approach to cancer treatment. This strategy, moreover, addresses the more aggressive breast tumor cell type, the highly proteolytically active potentially metastatic cells, for specific therapy. Our approach takes advantage of the amplified MYC expression typical of breast carcinoma to transactivate transfected vectors resulting in high level sense and antisense PAI-1 transcript production. These studies will provide information critical to the eventual design of tumor type-appropriate targetable delivery systems for genetic therapy of breast cancer.

Body of Report

We had originally hypothesized that over-expression of PAI-1 by malignant epithelial cells was an important aspect in the progression of a relatively indolent localized tumor to an invasive, highly metastatic, phenotype. Based on data summarized in the **Introduction**, our working model is that temporal changes in the expression, focalization, and or relative activity of urokinase PA/PAI-1 may influence cellular migration and invasive traits either as a direct consequence of extracellular matrix barrier proteolysis (**Figure 1 and 2**) or by modulating cellular adhesive interactions (via cycles of adhesion/de-adhesion) with the extracellular matrix (**Figure 2 and 3**). This model is consistent with recent findings indicating that PAI-1, specific integrins, and urokinase PA function coordinately to regulate adhesive events important in the control of cell movement. Our recently published observations (**Providence et al., 2000; manuscript appended**) provide initial experimental verification of this concept using a relatively simple culture system of induced epithelial cell locomotion over a planar substrate. Two aspects of this work are directly relevant to the working hypothesis of the present grant. Epithelial cells exhibit a location-specific distribution of PAI-1-expressing cells (i.e., only locomoting cells express this SERPIN) and down-regulation of PAI-1 synthesis and its matrix deposition in epithelial cells stably transfected with a PAI-1 antisense expression vector significantly impaired cell migration. Most importantly, it was possible to “rescue” a PAI-1 functionally-null motility-deficient epithelial cell line by transfection with a PAI-1 expression vector. Rescued cells expressed approximately normal levels of PAI-1 and efficiently locomoted in response to a denuding stimulus.

These results are consistent with the **Specific Aims** of this proposal which were (1) to generate transfectants of human breast carcinoma cells that vary in PAI-1 gene expression at both the mRNA and protein levels and to characterize the *in vitro* growth traits of these genetically-engineered cells, (2) to assess the *in vivo* growth characteristics of human breast carcinoma cells genetically-engineered to express different levels of PAI-1 using the results obtained in **Aim 1** to identify the most important candidate clones to evaluate, and (3) to initiate studies designed to assess the targetability of *in vivo*-implanted human breast tumor cells with potential therapeutically-relevant vectors as concluded from results obtained on work directed to **Aims 1 and 2**.

To achieve these aims, the goals in **Task 1** in the originally proposed **Statement of Work** were as follows:

Task 1: To assess the effects of vector-directed PAI-1 expression on *in vitro* growth traits of human breast carcinoma cells.

- (a) develop a panel of transfectant MCF-7 (estrogen responsive) and MDA-MB-231 (estrogen receptor negative) breast carcinoma cells which express differing levels of vector-driven PAI-1 mRNA and protein.
- (b) perform assays to assess the *in vitro* growth characteristics of the individual transfectant cell lines.
- (c) correlate levels of PAI-1 gene expression for each transfectant cell line with specific *in vitro* growth traits.

We have completed a substantial fraction of the work designed to address **Task 1**. A total of 31 different stable transfectant breast carcinoma cell lines were developed; 17 MCF-7 derived lines bearing a positive sense PAI-1 expression vector (either Rc/CMVPAI or Rc/E-BoxPAI; **Figure 4**) and in which PAI-1 mRNA levels varied from 0.8 ± 0.1 to 49.6 ± 9.0 fold over MCF-7 parental or vector without insert controls and 14 MDA-MB-231 antisense PAI-1 (either Rc/CMVIAP or Rc/E-BoxIAP; **Figure 4**) vector-derived lines in which PAI-1 mRNA abundance was down-regulated by 11 to 92 % compared to exponentially growing parental controls or cells transfected with vector without insert. A panel of 6 transfectant lines (for both the MCF-7 and MDA-MB-231 derived cell types) was selected for analysis of *in vitro* growth traits based on levels of PAI-1 expression significantly different from either of the parental strains. A quantitative analysis of these growth traits is summarized in **Table 1**. As a result of these analyses, it is anticipated that these same parental and transfectant cell lines will form the panel for the *in vivo* testing phase of this study (**as detailed in the original proposal**). In addition, we are currently generating additional transfectant cell lines in the MCF-7 cellular background which provide the unique quality of estrogen-inducibility of MYC expression thereby allowing for controlled vector-driven PAI-1 expression for continued growth trait assessments.

Key Research Accomplishments

- ❖ A panel of transfectant human breast carcinoma cell lines (derived from both MCF-7 and MDA-MB-231 parental stocks) was developed that varied in vector-driven synthesis of PAI-1 mRNA and protein. These cell lines are suitable for conduct of all *in vitro* and *in vivo* growth assessments as originally proposed.
- ❖ Comparisons between *in vitro* growth traits and PAI-1 expression as a function of cell growth activation indicated that MCF-7 cells were low to non-PAI-1 expressing regardless of proliferative stage (i.e., quiescent vs. cycling G1 vs. exponentially growing) whereas MDA-MB-231 cells expressed relatively high levels of PAI-1 mRNA/protein, particularly in serum-supplemented culture conditions. This differential in PAI-1 synthesis correlated with the low intrinsic motility (i.e., directed migration across denuded planar surfaces) of MCF-7 cells compared to the highly migratory phenotype of MDA-MB-231 carcinoma cells.
- ❖ Extent of cell spreading on vitronectin-coated bacteriological culture dishes was approximately inversely related to the level of PAI-1 expressed by transfected MCF-7 cells (i.e., MCF-7 cells attached and spread onto vitronectin; the extent of cell spreading decreased with increasing vector-driven expression of PAI-1). There was no direct quantitative relationship between MCF-7 cell spreading on fibronectin and PAI-1 levels although high PAI-1-expressing MCF-7 cells were flatter on fibronectin-coated dishes than their low-PAI-1 expressing counterparts. MDA-MB-231 parental cells that constitutively synthesized abundant PAI-1 mRNA/protein were highly motile and formed extensive membrane ruffles (indicative of a locomoting phenotype). PAI-1 antisense vector-directed down-regulation of PAI-1 synthesis in clonal isolates of MDA-MB-231 cells resulted in increased cell spreading (compared to parental controls), loss of membrane ruffling and decreased migration across a planar substrate.

- ❖ Increased PAI-1 expression in PAI-1 sense vector MCF-7 transfectants resulted in an increase in random migration as well as augmenting both the chemokinetic and chemotactic index. PAI-1 expression was necessary for elaboration of the migratory/invasive phenotype in MDA-MB-231 cells as vector-driven down-regulation of PAI-1 synthesis in this cell type reduced the fraction of cells capable of random, chemokinetic and chemotactic migration.

Reportable Outcomes

1. The following manuscripts, abstracts, and presentations directly resulted from support of this project by the Department of the Army under grant DAMD17-98-1-8015:

Providence KM, Kutz SM, Staiano-Coico L, Higgins PJ (2000) PAI-1 gene expression is regionally induced in wounded epithelial cell monolayers and required for injury repair. *Journal of Cellular Physiology* 182, 269-280 (published manuscript).

Lee F, Goncalves J, Faughman K, Steiner MG, Pagan-Charry I, Chin B, Providence KP, Higgins PJ, Staiano-Coico L (2000) Targeted inhibition of wound-induced PAI-1 Expression alters migration and differentiation in human epidermal keratinocytes. *Experimental Cell Research* 258 (manuscript accepted for publication).

White LA, Bruzdinski C, Kutz SM, Gelehrter TD, Higgins PJ (2000) Growth state-dependent binding of USF-1 to a proximal promoter E box element in the rat plasminogen activator inhibitor type-1 gene. *Experimental Cell Research* (manuscript submitted for publication).

Higgins PJ (2000) PAI-1 gene expression in breast carcinoma cells: implications for cellular migratory activity (abstract, Era of Hope Meeting, Atlanta, Georgia, June 8-12).

Higgins PJ (2000) "Molecular mechanisms underlying growth state-dependent PAI-1 gene Expression" (invited seminar, Stratton VA Medical Center, Albany, New York, Feb. 17).

Higgins PJ (2000) "Genetic targeting of PAI-1 gene expression: consequences on cellular Migration" (invited seminar, David Axelrod Institute, Cancer & Endocrine Signaling Seminar Series, NY State Department of Health, Albany, New York, March 13).

2. Development of cell lines:

All MCF-7 and MDA-MB-231 cell lines and their transfectant derivatives will be maintained in Dr. Higgins' laboratory. These cells will be made available upon request to members of the scientific community engaged in breast cancer research.

Conclusions

The following is a summary of the conclusions of the present report and the implications of the results obtained.

PAI-1 expression levels in indolent breast carcinoma cells (e.g., MCF-7) are low relative to the abundant expression of PAI-1 mRNA/protein characteristic of highly aggressive and metastatic breast tumor cell types (e.g., MDA-MB-231). PAI-1 synthesis in MCF-7 cells, moreover, was uninfluenced by growth state whereas PAI-1 was highly expressed in the phenotypically aggressive MDA-MB-231 cell line suggesting that expression is linked to the biological behavior of a particular breast tumor rather than simply to cellular proliferation. These results suggest that assessments of PAI-1 synthesis in breast cancers may represent an important parameter for patient classification. Patient presenting with high PAI-1-positive primary breast tumors may benefit from more aggressive therapy and post-operative surveillance. Analysis of our transfectant tumor cell lines additionally indicates that high levels of PAI-1 expression clearly modulates cell-to-matrix protein attachment properties and facilitates the elaboration of an invasive phenotype. Our studies detailing the effect of molecular targeting of PAI-1 gene expression in epithelial cells on induced directional migration into scrape-denuded "wounds" (Providence et al., 2000; manuscript appended) is consistent with the present findings implicating PAI-1 as an essential element in the migratory apparatus of breast carcinoma cells. Collectively, these data support the original hypothesis that the PAI-1 gene represents a reasonable (and now clearly an accessible) therapeutic target in the treatment and management of aggressive human breast cancers.

References

- Andreasen PA, Kjoller L, Christensen L, Duffy MJ (1997) The urokinase-type plasminogen activator system in cancer metastasis: a review. *Int J Cancer* 72, 1-22.
- Blasi F, Vassalli JD, Dano K (1987) Urokinase-type plasminogen activator: proenzyme, receptor, and inhibitors. *J Cell Biol* 104, 801-804.
- Blasi F (1996) The urokinase receptor and cell migration. *Semin Thromb Hemost* 22, 513-516.
- Blasi F (1997) uPA, uPAR, PAI-1: key intersection of proteolytic, adhesive and chemotactic highways? *Immunol Today* 18, 415-417.
- Carmeliet P, Moons L, Herbert JM, Crawley J, Lupu F, Lijnen R, Collen D (1997) Urokinase but not tissue plasminogen activator mediates arterial neointima formation in mice. *Circ Res* 81, 829-839.
- Ciambrone GJ, Mckeown-Longo PJ (1990) Plasminogen activator inhibitor type 1 stabilizes vitronectin-dependent adhesions in HT-1080 cells. *J Cell Biol* 111, 2183-2195.

Costantini V, Sidoni A, Deveglio R, Cazzato OA, Bellezza G, Ferri I, Bucciarelli E, Nenci GG (1996) Combined overexpression of urokinase, urokinase receptor, and plasminogen activator inhibitor-1 is associated with breast cancer progression. *Cancer* 77, 1079-1088.

Dano K, Behrendt N, Brunner N, Ellis V, Plough M, Pyke C (1994) The urokinase receptor. Protein structure and role in plasminogen activation and cancer invasion. *Fibrinolysis* 8, 189-203.

Duffy MJ (1992) The role of proteolytic enzymes in cancer invasion and metastasis. *Clin Exp Metastasis* 10, 145-155.

Duffy MJ (1996) Proteases as prognostic markers. *Clin Cancer Res* 2, 613-618.

Fersis M, Kaufmann M, Karmer MD, Wittmann G, Wallweiner D, Basert G (1996) Prognostic significance of plasminogen activator and its inhibitor PAI-1: predictors of poor response to tamoxifen therapy in recurrent breast carcinoma. *J Natl Cancer Inst* 87, 751-756.

Gandolfo GM, Conti L, Vercillo M (1996) Fibrinolytic components as prognostic markers in breast cancer and colorectal carcinoma. *Anticancer Res* 16, 2155-2159.

Mayerhofer K, Stozlechner J, Yildiz S, haider K, Heinzl H, Jakesz R, Pecherstorfer M, Rosen H, Svelda P, Zeillinger R, Speiser P (1996) Plasminogen activator inhibitor 1 and prognosis in breast carcinoma. *Geburt Frauenheil* 56, 23-27.

Pedersen H, Brunner N, Francis D, Osterlind K, Ronne E, hansen HH, Dano K, Grondahl-Hansen J (1994) Prognostic impact of urokinase, urokinase receptor, and plasminogen activator inhibitor-1 in squamous and large cell lung cancer tissue. *Cancer Res* 54, 4671-4675.

Pollanen J, Ross W, Vaheri A (1991) Directed plasminogen activation at the surface of normal and malignant cells. *Adv Cancer Res* 57, 272-328.

Romer J, Bugge TH, Pyke C, Lund LR, Flick MJ, Degen JL, Dano K (1996) Impaired wound healing in mice with a disrupted plasminogen gene. *Nat Med* 2, 287-292.

Schmitt M, Janicke F, Graeff H (1992) Tumor-associated proteases. *Fibrinolysis* 6, 3-26.

Torre EA, Fulco RA (1996) Tumor-associated urokinase-type plasminogen activator: significance in breast cancer. *Europ J Gynaecol Oncol* 17, 315-318.

Vaheri A, Stephens RW, Salon EM, Pollanen J, Tapiovaara H (1990) Plasminogen activation at the cell surface-matrix interface. *Cell Differen Develop* 32, 255-262.

APPENDIX

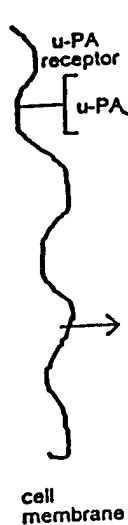

Figure 1 The plasminogen activation cascade. Conversion of the inactive zymogen plasminogen to the active broad spectrum protease plasmin is catalyzed by urokinase type plasminogen activator (u-PA) which is localized at the cell surface by virtue of interaction with its specific receptor. Plasminogen activator inhibitor type-1 (PAI-1) specifically inhibits this reaction resulting in a net decrease in pericellular proteolytic activity (adapted from Laiho and Keski-Oja, 1989).

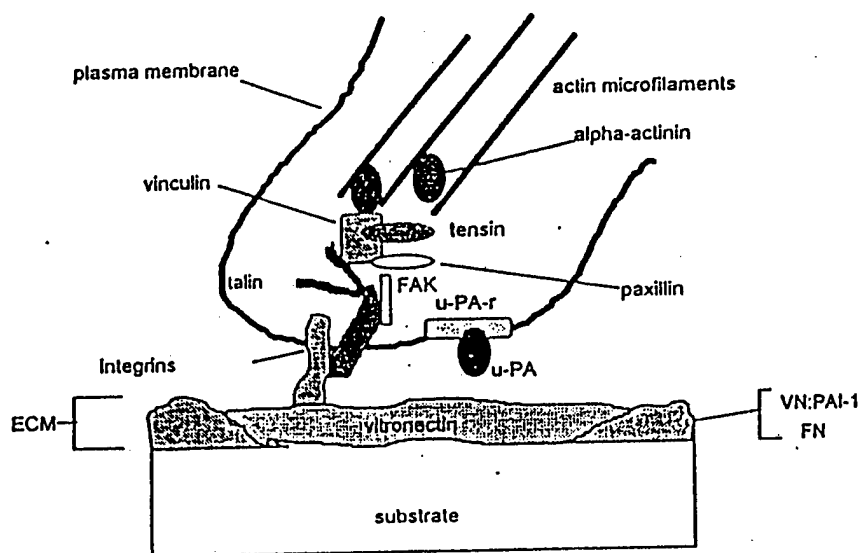

Figure 2 Idealized schematic illustrating localization of u-PA and PAI-1 at focal adhesion sites. The relationship between constituents of the focal contact and components of the plasmin-mediated proteolytic system demonstrate the potential importance of the plasmin-mediated proteolytic cascade as a regulator of cell-to-substrate adhesion. u-PA (associated with its receptor) and PAI-1 are localized to the extracellular face of the cell within and surrounding the focal contact, respectively (derived from Pollanen et al., 1991 and Ezzell, 1993).

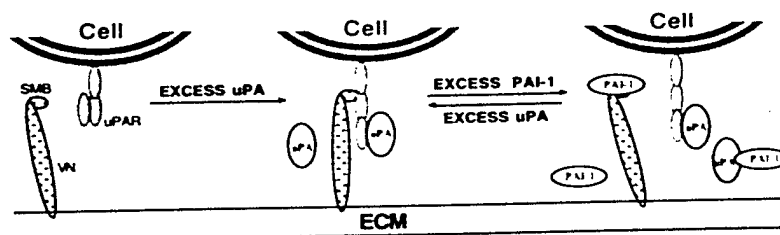

Figure 3 Model for the regulation of uPAR dependent cell adhesion and release by PAI-1 and uPA. (from Deng et al., 1996)

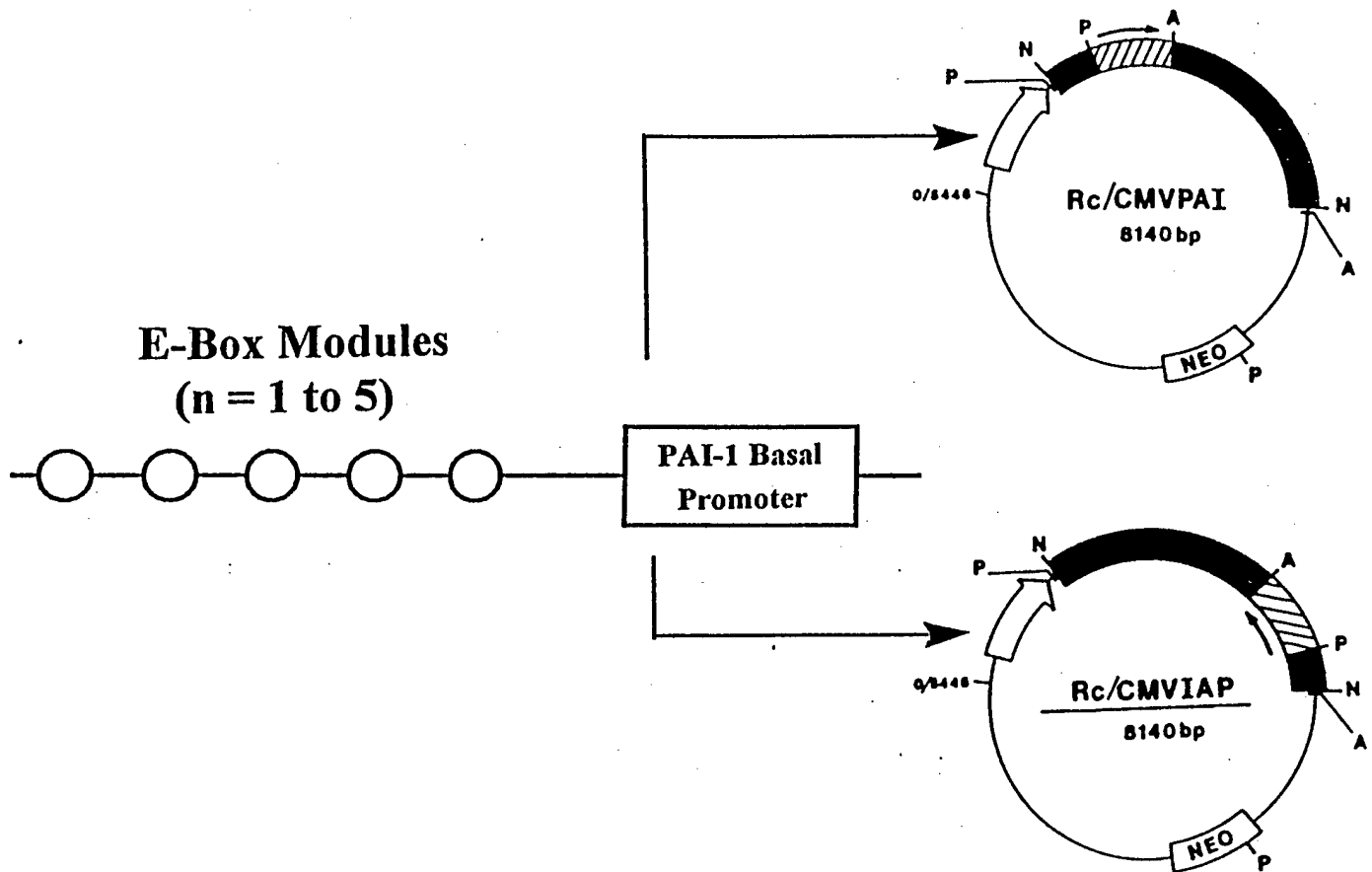

Figure 4 Strategy for construction of PAI-1 sense and antisense expression vectors under the control of E-box-driven transcription. The CMV promoter was restricted out of our previously designed Rc/CMV-based PAI-1 sense (PAI) and antisense (IAP) vectors (Higgins et al., 1997) and replaced with a cassette comprised of *myc*-responsive hexanucleotide E-box elements (varying in copy number from 1 to 5) and the basal PAI-1 promoter fragment (consisting of nucleotides -162 to -1 and containing the PAI-1 TATA box). This basal promoter fragment is necessary for transcriptional activation of the PAI-1 gene when ligated to various heterologous and PAI-1-specific enhancer elements but is itself a poor activating sequence.

Table 1. Migratory characteristics of parental and transfectant human breast carcinoma cell lines.

Cell Line	Relative PAI-1 Expression	Migration Indices	
		Chemokinetic	Chemotactic
MCF-7	1.0	276±129	366±109
7/CMV	0.8±0.1	201±74	290±59
7/EBPAI-D	4±1	297±101	431±207
7/CMVPAI-E	12±3	432±88	716±244
7/CMVPAI-B	22±5	699±121	701±153
7/CMVPAI-K	30±6	748±97	1289±346
7/CMVPAI-H	49±9	1121±277	3348±601
MDA-MB-231	100	742±93	2392±316
231/CMV	108±11	891±76	2203±237
231/CMVIAP-6	89±20	525±43	1114±179
231/CMVIAP-9	64±7	312±44	700±191
231/EBIAP-15	40±9	285±59	513±105
231/EBIAP-3	17±6	171±22	327±98
231/EBIAP-21	8±3	143±6	202±53

Relative PAI-1 Expression for MCF-7 transfectants = fold increase in de novo synthesized PAI-1 protein relative to parental cells (set at 1.0).

Relative PAI-1 Expression for 231 transfectants = % decrease in de novo synthesized PAI-1 protein relative to parental cells (set at 100%).

Migration Indices for the chemokinetic (without attractant gradient) and chemotactic (with attractant gradient) indicates the number of cells migrating to the lower chamber of a micro-chemotaxis apparatus within 3 hours after seeding of 5×10^4 cells to the upper chamber (methodology detailed in the original application).

PAI-1 Gene Expression Is Regionally Induced in Wounded Epithelial Cell Monolayers and Required for Injury Repair

KIRWIN M. PROVIDENCE,¹ STACIE M. KUTZ,¹ LISA STAIANO-COICO,²
AND PAUL J. HIGGINS^{1*}

¹Cell & Molecular Biology Program, Albany Medical College, Albany, New York

²Department of Surgery, Weill Medical College of Cornell University,
New York, New York

Induced expression of plasminogen activator inhibitor type-1 (PAI-1), a major negative regulator of pericellular plasmin generation, accompanies wound repair in vitro and in vivo. Since transcriptional control of the PAI-1 gene is superimposed on a growth state-dependent program of cell activation (Kutz et al., 1997, *J Cell Physiol* 170:8-18), it was important to define potentially functional relationships between PAI-1 synthesis and subpopulations of cells that emerge during the process of injury repair in T2 renal epithelial cells. Specific cohorts of migratory and proliferating cells induced in response to monolayer trauma were spatially as well as temporally distinct. Migrating cells did not divide in the initial 12 to 20 h postinjury. After 24 h, S-phase cells were generally restricted to a region 1 to 2 mm from, and parallel to, the wound edge. Proliferation of wound bed cells occurred subsequent to wound closure, whereas the distal contact-inhibited monolayer remained generally quiescent. Hydroxyurea blockade indicated, however, that proliferation (most likely of cells immediately behind the motile "tongue") was necessary for maintenance of cell-to-cell cohesiveness in the advancing front, although the ability to migrate was independent of proliferation. PAI-1 mRNA expression was rapidly up-regulated in response to wounding with inductive kinetics approximating that of serum-stimulated cultures. Differential harvesting of T2 cell subpopulations, based on proximity to the injury site, prior to Northern assessments of PAI-1 mRNA abundance indicated that PAI-1 transcripts were restricted to cells immediately bordering the wound or actively migrating and not expressed by cells in the distal contact-inhibited monolayer regions. Such cell location-specific distribution of PAI-1-producing cells was confirmed by immunocytochemistry. PAI-1 synthesis in cells that locomoted into the wound field continued until injury closure. Down-regulation of PAI-1 synthesis and matrix deposition in renal epithelial cells, stably transfected with a PAI-1 antisense expression vector, significantly impaired wound closure. Transfection of the wound repair-deficient R/A epithelial line with a sense PAI-1 expression construct restored both approximately normal levels of PAI-1 synthesis and repair ability. These data indicate that PAI-1 induction is an early event in creation of the wound-activated phenotype and appears to participate in the regulation of renal epithelial cell motility during in vitro injury resolution. *J. Cell. Physiol.* 182:269-280, 2000. © 2000 Wiley-Liss, Inc.

Extracellular matrix (ECM) restructuring following tissue injury is regulated (both temporally and spatially) by the plasmin-based pericellular proteolytic cascade and by members of the metalloproteinase family (Dano et al., 1985; Laiho and Keski-Oja, 1989; Pilcher et al., 1997; Pollanen et al., 1991). Recent in situ and genetic analyses of the repair process suggest that the migratory, proliferative, and ECM remodeling stages of in vivo wound healing are dependent, to a significant extent, on plasminogen activation (i.e., the conversion of plasminogen to the active broad-spectrum protease plasmin by urokinase plasminogen activator [uPA]) (Pollanen et al., 1987, 1991; Schafer et al.,

1994; Okada et al., 1995; Pappot et al., 1995; Jensen and Lavker, 1996; Romer et al., 1996; Carmeliet et al., 1997; Hasenstab et al., 1997; Carmeliet and Collen,

Contract grant sponsor: NIH; Contract grant numbers: DK46272 and GM4246; Contract grant sponsor: Department of the Army; Contract grant number: DAMD17-98-1-8015.

*Correspondence to: Dr. Paul J. Higgins, Cell & Molecular Biology Program (Mailcode-165), Albany Medical College, 47 New Scotland Avenue, Albany, NY 12208.
E-mail: phiggins@ccgateway.amc.edu

Received 30 June 1999; Accepted 10 September 1999

1998). Studies in mice genetically engineered to be deficient in one or more elements in the plasmin activation cascade, for example, have confirmed the importance of uPA and plasmin in cell migration at specific injury sites (e.g., Romer et al., 1996; Carmeliet et al., 1997). Plasminogen activator inhibitor type-1 (PAI-1) functions in this process to negatively regulate plasmin generation by complexing with and inhibiting the catalytic activity of free as well as receptor-bound uPA (e.g., Ellis et al., 1990; Laiho and Keski-Oja, 1989) modulating, thereby, uPA-dependent motility *in vivo* (Carmeliet and Collen, 1995; Carmeliet et al., 1997). Indeed, it appears that various aspects of an efficient response to trauma, including the growth factor-dependent recruitment of endothelial cells into the wound field (Sato and Rifkin, 1988), require precise control over both the expression and localization of particular proteases and protease inhibitors (Andreasen et al., 1997; Pepper et al., 1993).

Cell type-specific synthesis and subcellular targeting of PAI-1 and uPA appear to be important considerations in the modulation of the pericellular proteolytic balance. Following injury, uPA and PAI-1 are initially produced by cells immediately adjacent to the wound edge *in vivo* as well as *in vitro* (Romer et al., 1991; Pawar et al., 1995; Reidy et al., 1995; Staiano-Coico et al., 1996; Carmeliet et al., 1997), where PAI-1 is likely stabilized in an active conformation with ECM-associated vitronectin (Declercq et al., 1988; Mimuro and Loskutoff, 1989a,b; Seiffert et al., 1990; Vassalli et al., 1991). Temporal changes in the expression, focalization, and/or relative activity levels of this protease/inhibitor pair may influence cell migration either as a direct consequence of ECM barrier proteolysis or by modulating cellular adhesive interactions with the ECM (Ciambrone and McKeown-Longo, 1990; Blasi, 1996, 1997; Jensen and Lavker, 1996; Carmeliet et al., 1997). Furthermore, recent findings indicate that PAI-1, specific integrins, and uPA function coordinately to influence adhesive events important in the control of cell movement (Carmeliet and Collen, 1995, 1996; Stefansson and Lawrence, 1996; Blasi, 1997; Waltz et al., 1997).

Proliferation is also an essential, albeit presumed independent, component in the closure of epithelial monolayer wounds (Pawar et al., 1995). The exact relationship between regenerative growth and trauma repair, however, remains to be defined (Jensen and Lavker, 1996; Zahm et al., 1997). Within the setting of induced cellular proliferation and migration, stimulated expression of PAI-1 appears associated with both processes (e.g., Bade and Feindler, 1988; Pepper et al., 1992; Thornton et al., 1994; Ryan et al., 1996; Kutz et al., 1997). Transcriptional regulation of the PAI-1 gene, moreover, is superimposed on a growth state-dependent program, which culminates in a proliferative response (Ryan et al., 1996; Kutz et al., 1997). Kinetic assessments indicate that PAI-1 transcription and mRNA expression, similar to that of uPA (Grimaldi et al., 1986), occur early and in immediate-early response (IER) fashion on addition of serum to quiescent cells (Ryan and Higgins, 1993; Ryan et al., 1996; Uno et al., 1997), thereby mimicking regenerative events *in vivo* (Schneiderman et al., 1993; Thornton et al., 1994). The PAI-1 gene, however, exhibits a complex mode of reg-

ulation on entry of G_0 -arrested cells into a cycling G_1 condition (Ryan et al., 1996). Serum-induced PAI-1 transcription is maximal in mid- G_1 and declines abruptly prior to the onset of DNA synthesis (White et al., 1999). The amplitude as well as maintenance of expression through mid- G_1 phase is anchorage responsive and this latter adhesion-dependent requirement, unlike initial induction, involves secondary (i.e., protein synthesis-dependent) transcriptional-level events (Ryan et al., 1996). These data provided for a model of PAI-1 gene control in serum-stimulated cells, which incorporates both IER and secondary regulatory influences within an "activated" G_1 state (Kutz et al., 1997; Mu et al., 1998). Such fine control over the kinetics of PAI-1 expression appears to be one modulating aspect in the complexity of G_1 progression. In this regard, PAI-1 may regulate cell-to-substrate adhesion (a necessary prerequisite for G_1/S transition [Guadagno and Assoian, 1991; Guadagno et al., 1993]) or cell shape (and shape-dependent metabolic pathways [e.g., Higgins et al., 1994; Hawks and Higgins, 1998]) by directly influencing the immediate pericellular proteolytic microenvironment (Laiho and Keski-Oja, 1989). PAI-1-dependent ECM stabilization, moreover, may indirectly facilitate the formation of cell-ECM interactions necessary for cellular adhesion and/or migration (e.g., Planus et al., 1997).

Such *in vitro* observations, in fact, do have *in vivo* correlates. The morphology of the flattened regenerating renal epithelium, for example, is dramatically different from the normally quiescent highly polarized tubular cell (e.g., Wallin et al., 1992) and PAI-1 expression occurs specifically in regenerating proximal tubular cells following ischemia-reperfusion renal injury (Basile et al., 1998), suggesting a functional role in tissue repair. Clearly, the association between the activated phenotype and targeted accumulation of PAI-1 in the cellular undersurface in close proximity to newly formed focal adhesions is consistent with this function (Kutz et al., 1997). The time course of induced PAI-1 expression and the involvement of the PAI-1-synthesizing cellular cohort in the response to injury, however, are poorly understood. It is important, therefore, to clarify the kinetics of PAI-1 expression with regard to the emergence of specific cell subpopulations (i.e., migratory, proliferating) involved in repair growth and to assess the role of this protease inhibitor in the regenerative process.

MATERIALS AND METHODS

Cell lines and *in vitro* repair assay

The independent clonal isolates (EC-1 and T2), derived from an early-passage culture of normal rat kidney (NRK) epithelial cells (Ryan and Higgins, 1993), were maintained in DMEM medium supplemented with 10% (v/v) fetal bovine serum (FBS) (DMEM/10). Cells were grown to confluency and the media changed to fresh DMEM/10 for maintenance in a postconfluent condition for an additional 3 days. Alternatively, confluent cultures were maintained in serum-free DMEM for 3 days to initiate a contact-inhibited/serum-deprivation state of growth arrest. Wounds were created by pushing the narrow end of a sterile P1000 plastic pipette tip (Continental Laboratory Products, San Diego, CA) through the monolayer. Cultures were incubated

in the existing media for times indicated in the text. Wound closure was assessed by time-lapse photomicroscopy and injury repair rates calculated, as a function of time, from measurements made utilizing an inverted microscope fitted with a calibrated ocular grid.

Growth "activation" of cells arrested in serum-deficient medium

The growth medium in low-density 150-mm dish cultures was aspirated, the cells rinsed twice in Hanks' balanced salt solution (HBSS) (1.3 mM CaCl₂, 5 mM KCl, 0.3 mM KH₂PO₄, 0.5 mM MgCl₂ · 6H₂O, 0.4 mM MgSO₄ · 7H₂O, 0.14 M NaCl, 4 mM NaHCO₃, 0.3 mM Na₂HPO₄, 5.6 mM glucose), and serum-free DMEM added (which initiates a rapid G₀ arrest of NRK cells; Kutz et al., 1997). After 3 days, cultures were left untreated or exposed to actinomycin D (5 µg/ml), puromycin (20 and 100 µg/ml), or genistein (50 and 100 µM) for 30 min prior to, and during, stimulation with FBS (added directly to the quiescence maintenance medium to a final concentration of 20%). Cells were harvested for analysis of PAI-1 transcripts (described later) at times indicated in the text.

RNA analysis of cell subpopulations

Cells immediately adjacent to the wound (termed *edge-isolates*) were harvested by pushing the blunt (wide) end of a P1000 plastic pipette tip along the existing wound tract, displacing cells directly at, and 5 mm from, the wound edge; such scrape-released cells were subsequently collected by centrifugation at 1400 × g. Cells located between 10 and 40 mm from the wound border (i.e., in the intact monolayer regions) were collected in the same manner and termed *monolayer-isolates*. In some cases, the entire culture population was harvested with a cell scraper (*total dish-isolates*). Cellular RNA was extracted (Kutz et al., 1997) and denatured by incubation at 55°C for 15 min in 1X MOPS, 6.5% formaldehyde, and 50% formamide prior to electrophoresis (10 µg RNA/lane) on agarose/formaldehyde gels (1.2% agarose, 1.1% formaldehyde, 1X MOPS, pH 8.0) for 3 h at 70 V in 1X MOPS. Fractionated RNA was transferred to positively charged nylon membranes via downward capillary action using the turboblotter system (Schleicher & Schuell, Keene, NH) and UV crosslinked. Hybridization with [³²P]-dCTP-labeled cDNA probes to rat PAI-1 and mouse A50 was as described (Ryan et al., 1996). Blots were exposed to X-OMAT AR-5 film (Kodak, Rochester, NY) or analyzed with a Storm PhosphorImager (Molecular Dynamics, Sunnyvale, CA) for visualization and quantitation of mRNA species.

Immunocytochemistry

Cultures were washed twice in Ca²⁺/Mg²⁺ free phosphate-buffered saline (CMF-PBS; 2.7 mM KCl, 1.2 mM KH₂PO₄, 0.14 M NaCl, 8.1 mM Na₂HPO₄ · 7H₂O) and fixed for 10 min at room temperature in 10% formalin/CMF-PBS. Following permeabilization with cold (4°C) 0.5% Triton X-100/CMF-PBS for 10 min at 4°C, cells were washed three times (5 min each) with CMF-PBS prior to incubation (3 h at room temperature) with rabbit antibodies to rat PAI-1 (Kutz et al., 1997) diluted in BSA (3 mg/ml)/CMF-PBS. After three CMF-PBS washes, cells were incubated with fluorescein-

conjugated goat anti-rabbit IgG (Chemicon, Temecula, CA; diluted 1:20 in BSA/CMF-PBS) for 30 min at 37°C, washed, and coverslips mounted with 100 mM *n*-propylgalate in 50% glycerol/CMF-PBS. Where indicated, 4 µM monensin (Sigma, St. Louis, MO) was added to wounded monolayers prior to fixation. For identification of DNA-synthesizing cells, 5-bromo-2'-deoxyuridine (BrdU) (200 µmol/l final concentration) was added to cultures at time of wounding. The number and location of cells that incorporated the analogue (S-phase cells) were assessed by indirect immunofluorescence, using monoclonal antibodies to BrdU (Mu et al., 1998).

Construction and transfection of sense and antisense PAI-1 expression vector

pBluescript, containing a full-length rat PAI-1 cDNA (Higgins and Ryan, 1992), was digested with *Eco*RI and *Hind*III to generate a 2.6-kb insert (representing nucleotides -118 to +2572 relative to the start site of transcription). Agarose gel-purified DNA was blunt-ended with Klenow fragment/dNTPs using a fill-in reaction. *Not*I linkers were ligated, the fragments digested with *Not*I, and purified by agarose gel electrophoresis. Flanked inserts were ligated to *Not*I-digested calf intestinal phosphatase-treated gel-purified Rc/CMV expression vector DNA and subsequently transformed into competent INVαF' *E. coli*. Plasmid DNA was isolated from ampicillin-resistant colonies; restriction endonuclease digestion and Southern blot analysis, using a 726-bp *Pst*I/*Apa*I-digested cDNA fragment as a probe, confirmed sense (Rc/CMVPAI) and antisense (Rc/CMVIAP) insert orientation (Higgins et al., 1997). Insert template activity was assessed in vitro for both constructs using T7 polymerase to initiate PAI-1 antisense and sense transcripts (confirmed by hybridization analysis and coupled STP3 transcription-translation [Novagen]/Western blotting, respectively). Cells were transfected with 20 µg of plasmid DNA using the calcium phosphate technique (Higgins et al., 1991). Stable transfectants were selected with G418 (150 µg/ml), and resistant clones were isolated and expanded in growth medium containing G418. Since T2 cells were highly resistant to G418, stable antisense-expressing clones were derived using the EC-1 line.

Metabolic labeling, cell extraction, and gel electrophoresis

Cells were washed with HBSS, then labeled in serum-/methionine-free RPMI 1640 medium containing 50 µCi [³⁵S]methionine/ml (specific activity = 1100 Ci/mmol) (Ryan and Higgins, 1993). The conditioned labeling medium was aspirated and monolayers washed with CMF-PBS prior to extraction with 0.2% (w/v) saponin in CMF-PBS to isolate cell-substratum contact regions and associated undersurface proteins (Higgins et al., 1990, 1991). Saponin-resistant (SAP fraction) residues were scraped into sample buffer (50 mM Tris/HCl, pH 6.8, 10% glycerol, 1% SDS, 1% 2-mercaptoethanol) and boiled. For electrophoresis, 25,000 cpm trichloroacetic acid-insoluble SAP-fraction protein were separated on SDS/9% acrylamide slab gels (Ryan and Higgins, 1988). Labeled protein bands were visualized by fluorography and quantified by computerized densitometry (Smith et al., 1992). Identification

TABLE 1. Kinetics of wound closure in scrape-injured T2 cell monolayers

Hours postwounding ¹	Wound width ²	% Injury repair	Closure rate ³
0	9.68 ± 0.20	0	—
2	9.21 ± 0.22	4.8	2.4
4	8.66 ± 0.29	10.5	2.6
6	8.35 ± 0.33	13.7	2.3
9	7.23 ± 0.39	25.3	2.8
12	6.32 ± 0.43	34.0	2.8
21	3.97 ± 0.51	58.9	2.8
26	2.18 ± 0.58	77.0	2.9
30	1.62 ± 0.45	83.3	2.8
36	0	100	—

¹A contact-inhibited monolayer of T2 cells was scrape-wounded and the extent of injury repair (measured by a calibrated ocular grid and expressed as percent closure) plotted as a function of time postinjury.

²Width of the remaining unhealed region was measured in arbitrary units with a calibrated ocular grid. Data represent the mean ± SD of 10 individual assessments.

³Closure rate = $\frac{\text{mean \% repair}}{\text{time (h) postwounding}}$

of the rat PAI-1 protein in one-dimensional electrophoretic separations utilized criteria described previously (Higgins et al., 1989, 1990) as well as by immunohistochemical reactivity with PAI-1-specific antibodies (Higgins et al., 1990).

RESULTS

Kinetics of the repair response

Cellular movement into the wound "bed" occurred relatively quickly (i.e., within 1 h after monolayer scraping). Trauma site closure proceeded at a constant rate and was complete by 30 to 36 h after injury in this model (Table 1). Time-lapse videomicroscopy and examination of fixed, acridine orange-stained, T2 cell cultures confirmed that relatively close cell-to-cell contact in the migrating tongues, as well as within the distal monolayer regions, was maintained throughout the repair process (i.e., solitary migratory cells did not enter the denuded zone; see later discussion). An absence of mitotic cells in the migratory cohort was also apparent in the time-lapse assessments, suggesting that the mobile population does not divide (at least during the initial 12 to 20 h after wounding). Mitotic cells were evident, however, in regions of the monolayer approximately 1 to 2 mm from, and parallel to, the edge of the original scrape injury (at 24 h after wounding) and within the confines of the initial injury site (only after the opposing fronts made contact) but not in the distal monolayer.

This regional compartmentalization of T2 cells with differing proliferative kinetics, moreover, suggests that a relationship exists between entry into the division cycle and distance from the wound. To assess this possibility, the culture medium was supplemented with 200 μmol/l BrdU at the time of scraping specifically to identify cells that enter S phase in response to injury. This quantitative approach, when applied over the entire time course of monolayer repair, confirmed that (1) confluent T2 cells are, in fact, contact inhibited; (2) 24 h postinjury, the majority of S-phase cells concentrate in a region approximately 1 to 2 mm from, and parallel to, the wound edge and (to a lesser extent) in some leading edge cells; and (3) proliferation of cells that had entered

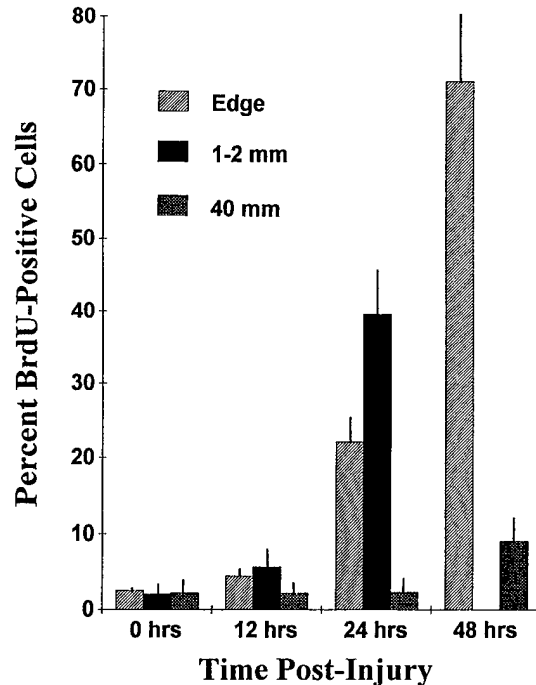

Fig. 1. T2 cells synthesize DNA as a function of their spatial relationship to the wound site. The fraction of S-phase cells is low in uninjured monolayers or in scraped cultures at early times (i.e., ≤12 h) postinjury. By 24 h after wounding, most proliferating cells (as determined by immunocytochemical detection of BrdU incorporation) occur within the first 1 to 2 mm from, and parallel to, the wound edge, although S-phase cells also begin to appear at the leading edge. Cells in the distal monolayer (i.e., 40 mm from the injury site) remain generally quiescent throughout the repair process. The fraction of DNA-synthesizing cells in the distal regions increases only slightly (i.e., comprising <10% of the total population) after complete closure (by approximately 36 h). The healed wound bed population (i.e., "Edge" cells at the 48-h time point) proliferate vigorously in the postclosure period. Percent S-phase (BrdU-positive) cells was determined by counting 10 random fields representative of each of the indicated culture areas for three independent experiments; data plotted represent the mean ± SD of such assessments.

the wound bed occurs subsequent to scrape closure (Fig. 1). The presence or absence of conditioned serum had no significant effect on repair regional kinetics (i.e., the rate of closure differed by only 10 to 15% for cultures wounded in serum-containing as compared to serum-free medium).

To ascertain whether migration alone is sufficient to achieve wound closure, T2 monolayers were scrape-injured in the presence of 0.4 mM hydroxyurea (HU) to inhibit ribonucleoside diphosphate reductase activity (Krakoff et al., 1968; Wang et al., 1997). Preliminary experiments indicated that this concentration of HU effectively inhibited serum-induced DNA synthesis in NRK cells. HU-treated T2 cultures exhibited the same initial morphologic response to wounding as control populations (i.e., membrane ruffling and cell spreading occurred within 30 min of injury followed by migration into the denuded area). By 12 h postinjury, however, the integrity of the migrating sheet was lost in HU-treated cells; after 24 h (a time point that correlated with a significant increase in the fraction of BrdU-positive cells in control cultures; e.g., Fig. 1), there was a complete HU-associated loss of cell-to-cell contact at

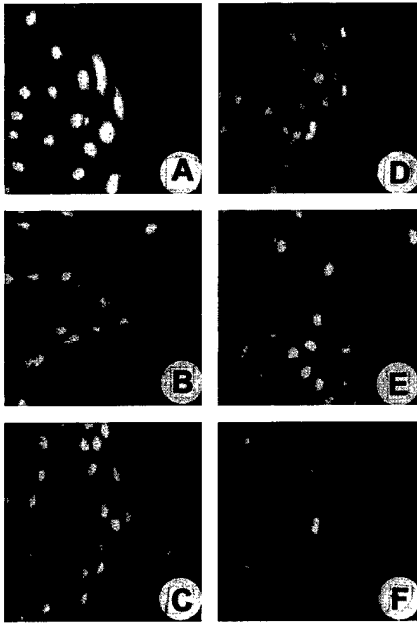

Fig. 2. Effects of hydroxyurea (HU) on the repair response by T2 cells. In control wounded monolayers, the migratory tongue advanced as a generally uniform sheet of closely juxtaposed cells (A, B, C = 6, 12, 24 h, respectively, after scraping). Such cohesion was lost in HU-treated cultures (D, E, F = 6, 12, 24 h, respectively, postinjury). HU-associated loss of cell-to-cell contact was evident within 12 h (E) and clearly obvious by 24 h (F) postwounding; cell morphology was unaffected by HU. In each panel, the direction of migration is from left to right into the denuded zone. For acridine orange histochemistry, cells were permeabilized in 0.08 N HCl, 0.15 M NaCl, and 0.1% Triton X-100 for 30 sec, then incubated in staining buffer (0.2 M Na₂HPO₄, 0.1 M citric acid, pH 6.0, 1 mM disodium EDTA, 0.15 M NaCl, 6 μ g acridine orange/ml). UV light microscopy, $\times 50$.

the leading edge (Fig. 2). Migratory activity, however, appeared unaffected by HU, since cells from opposing, albeit noncohesive, "fronts" made contact within the same time frame (i.e., 30 to 36 h) as in untreated populations. Migration, therefore, occurs independently of proliferation, although proliferation (most likely of cells immediately behind the mobile tongue) is necessary for maintenance of monolayer integrity in the zone of repair.

Characteristics of induced PAI-1 expression in wound-"activated" cultures

The temporally and spatially distinct phases of migration and proliferation are associated with the wound-"activated" phenotype (Figs. 1 and 2). It was, therefore, important to assess whether induced PAI-1 expression was an element in this repair response and, if so, to determine both the time course of PAI-1 transcript synthesis and in situ distribution of PAI-1 expressing cells relative to the site of injury. Similar to serum-stimulation of quiescent NRK cell cultures (used for a kinetic comparison; e.g., Fig. 3), wounding-induced PAI-1 mRNA transcripts are first detectable in total dish-isolates of T2 cells within 30 min to 1 h after monolayer scraping (Fig. 4). PAI-1 mRNA is maximally expressed between 1 and 2 h posttrauma, declining dramatically by 14 h (Fig. 4) and closely approximating the changing transcript abundance typical of serum-

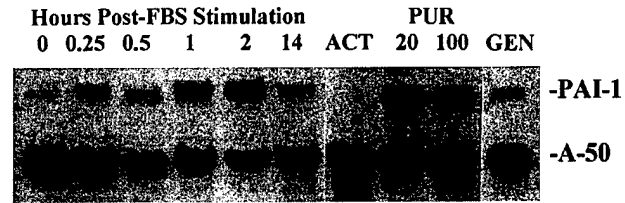

Fig. 3. Time course and metabolic characteristics of serum-induced PAI-1 gene expression. Quiescent T2 cell cultures were stimulated by direct addition of serum (to a final concentration of 20%); control cultures were maintained in serum-free DMEM (time 0). RNA was isolated at the times indicated post-FBS addition. For assessment of the metabolic requirements of serum-induced PAI-1 expression, cells were pretreated with actinomycin D (ACT; 5 μ g/ml), puromycin (PUR; 20 or 100 μ g/ml), or genistein (GEN; 100 μ M) prior to addition of FBS; RNA was extracted from inhibitor-treated cultures 4 h after serum stimulation. Northern blots were hybridized with ³²P-labeled PAI-1 and A-50 cDNA probes simultaneously. PAI-1 transcriptional activation in response to serum had IER characteristics and was genistein-sensitive. Identical results were obtained in four different experiments.

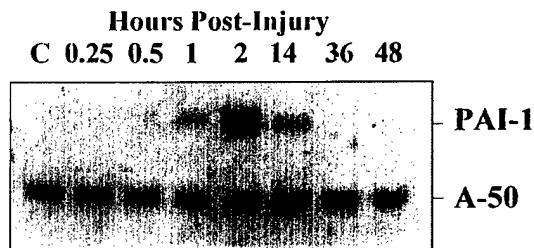

Fig. 4. Induction of PAI-1 in mRNA response to wounding. Confluent T2 monolayers were scrape-wounded and RNA from total dish-isolates extracted at the times indicated. Northern blots were hybridized with ³²P-labeled PAI-1 and A-50 cDNA probes simultaneously. PAI-1 transcripts were evident as early as 30 min to 1 h after injury, expression was maximal at 2 h, and declined to levels comparable to quiescent controls by 36 h. C = quiescent nonwounded T2 cells. Blot shown is representative of three individual experiments.

stimulated cultures (Fig. 3). To ascertain specifically which cells within injured cultures express PAI-1, RNA was extracted from individual edge- and monolayer-isolates at various times postscraping. PAI-1 mRNA was rapidly induced (by 2 h) after injury in edge-isolates, declined quickly thereafter, and by 24 h post-trauma PAI-1 mRNA levels in cells at the injury site approximated that of nonwounded controls (Fig. 5). PAI-1 transcript abundance in distal monolayer-isolates, in contrast, did not change over the time course of repair, remaining similar to that of quiescent cultures.

In situ assessments of PAI-1 accumulation confirmed the RNA analysis. Consistent with the Northern blot data (Figs. 4 and 5), contact-inhibited T2 cells expressed only low levels of PAI-1 protein. Continuous migration into the denuded area, combined with the observation that the distal monolayer does not express PAI-1 mRNA (Fig. 5), suggests that PAI-1 protein synthesis may be restricted to leading edge cells and cells proximal to the site of injury (i.e., within the region of the migrating tongue). To address this issue, monensin (a Na⁺/K⁺ ionophore that interferes with several metabolic functions, including protein secretion but not synthesis [Ledger et al., 1980; Uchida et al., 1980]) was

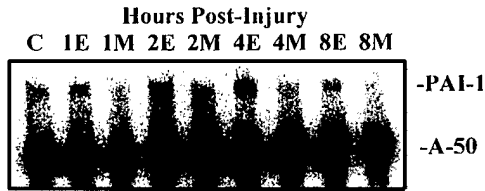

Fig. 5. Regional specificity of induced PAI-1 mRNA expression. Confluent T2 monolayers were wounded and RNA isolated at various times postinjury from cells bordering the wound edge (E = edge-isolates) or in the distal monolayer region (M = monolayer-isolates). Northern blots were hybridized with 32 P-labeled PAI-1 and A-50 cDNA probes simultaneously; blot shown is representative of triplicate experiments. PAI-1 transcript expression was restricted to cells at the wound edge. The time course of PAI-1 induction in edge-isolates was similar to that of total dish-isolates (e.g., Fig. 4).

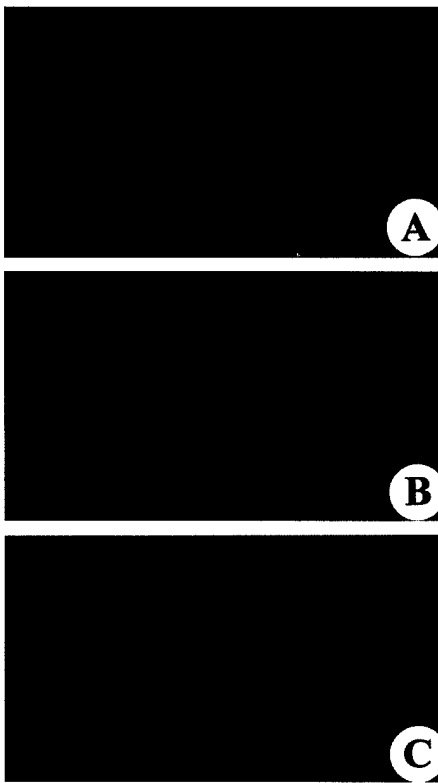

Fig. 6. Relationship between PAI-1 immunoreactive T2 cells and site of injury. Monensin treatment was used to inhibit protein secretion to maximize the likelihood of detection of de novo synthesized PAI-1 protein. In response to wounding, PAI-1 protein specifically localizes to cells adjacent to the wound edge with minimal synthesis by distal monolayer region cells. (A) nonwounded monolayer; (B) edge, 4 h postinjury; and (C) monolayer, 4 h postinjury. Indirect immunofluorescence microscopy, $\times 185$.

added to cultures at the time of wounding. Immunocytochemical evaluation of monensin-treated cultures confirmed the Northern assessments; de novo PAI-1 protein synthesis occurs primarily by cells immediately adjacent to the wound edge (Fig. 6). Coincident with the wound-induced expression of PAI-1 mRNA transcripts (e.g., Fig. 5), and at every time point thereafter, immunoreactive PAI-1 protein was resolved both at the

TABLE 2. Inhibition of wound closure by genistein

Serum ¹	Hours postwounding	Treatment ²	% Injury repair ³
None	2	DMSO	4.43 \pm 0.62
		50 μ M	4.92 \pm 0.92
		100 μ M	3.61 \pm 1.69
None	12	DMSO	35.01 \pm 6.37
		50 μ M	22.62 \pm 3.33
		100 μ M	15.62 \pm 3.34
None	24	DMSO	76.97 \pm 0.83
		50 μ M	41.05 \pm 6.59
		100 μ M	27.67 \pm 6.19
10%	2	DMSO	4.72 \pm 0.83
		50 μ M	4.18 \pm 0.48
		100 μ M	3.58 \pm 0.54
10%	12	DMSO	39.83 \pm 2.99
		50 μ M	27.66 \pm 4.38
		100 μ M	20.61 \pm 3.24
10%	24	DMSO	92.27 \pm 3.41
		50 μ M	61.59 \pm 5.72
		100 μ M	46.89 \pm 7.73

¹Contact-inhibited monolayers (in serum-free or 10% FBS-containing DMEM) of T2 cells were scrape-wounded and the extent of injury repair (measured by a calibrated ocular grid and expressed as percent closure) plotted as a function of time postinjury (as in Table 1).

²Cultures were incubated in DMSO (solvent control) or the indicated concentrations of genistein by direct addition to the maintenance medium immediately after wounding.

³Data represent the mean \pm SEM for three independent experiments.

migrating edge and within cells proximal to the closing wound bed. PAI-1 synthesis continues until wound closure with only minimal expression in the distal monolayer.

Consequences of PAI-1 expression manipulation on in vitro wound repair

Location-specific induced expression of PAI-1 mRNA and protein within the wound field (e.g., Figs. 4 to 6) suggested that, if PAI-1 was functionally related to the repair process, inhibition of synthesis by cells at the site of trauma might affect either the time course of injury resolution or the recruitment of cells into the denuded zone. Monensin was not appropriate for this evaluation. Initial studies indicated that this drug did reduce, but not completely inhibit, PAI-1 secretion and accumulation in the cellular undersurface region. Thus, monensin was useful for in situ studies (e.g., Fig. 6) but of limited value for functional assessments. Additional pharmacologic and molecular genetic approaches were designed, therefore, to address this issue. The tyrosine kinase inhibitor genistein was selected as the pharmacologic agent, since cell shape-dependent PAI-1 transcription (Hawks and Higgins, 1989), serum-induced PAI-1 expression (Fig. 3), and cell proliferation/angiogenic responses (Fotsis et al., 1993) are sensitive to genistein treatment. Initial experiments indicated that the time course of PAI-1 mRNA expression by NRK cells bordering the wound margin was similar to that of serum-stimulated cells (Figs. 5 and 6); moreover, PAI-1 induction in response to serum (e.g., Fig. 3) and scrape injury (data not shown) was inhibited by genistein. Genistein-mediated suppression of PAI-1 transcription was evident at concentrations of inhibitor that effectively reduced migration (e.g., Table 2).

A molecular genetic approach was devised, therefore, in which EC-1 cells were stably transfected with an

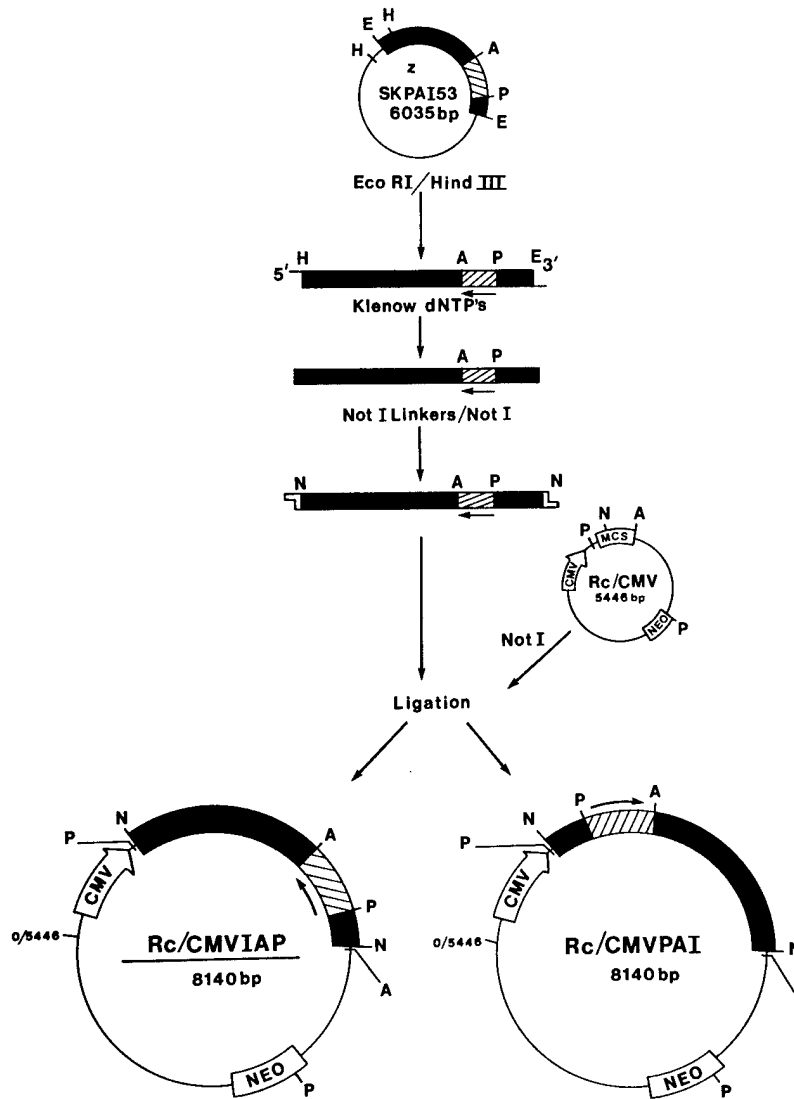

Fig. 7. Construction of sense (PAI) and antisense (IAP) expression vectors. Cloning of PAI-1 cDNA (nucleotides -118 to +2572) into the *NotI* site of the 5.4-kb Rc/CMV vector was as detailed (Materials and Methods). Topography of known restriction sites (P, *PstI*; N, *NotI*; A, *ApaI*) was used to assess insert orientation.

expression vector (Rc/CMVIAP) bearing a PAI-1 cDNA insert in antisense configuration (Fig. 7) to specifically assess the relationship between wound-induced PAI-1 expression and cell migration. One derived line (Rc/CMVIAP-4HH) was selected for analysis since gel electrophoresis of the SAP fraction protein complement indicated that the 4HH clone was functionally PAI-1 "null" (Fig. 8). Injury site closure by the 4HH derivative was significantly impaired relative to EC-1 parental cells and Rc/CMV transfectants (Fig. 9). Wounds in 4HH monolayers were less than 60% "healed," even at the protracted time of 84 h postscraping, compared to collaterally evaluated controls for which more than 92% repair was typically achieved within the 30 to 36 h window (Fig. 9) and closure complete by 40 h or less. It was not possible to "rescue" the 4HH healing-deficient

phenotype by transfection with the Rc/CMVPAI sense expression vector; surviving clones consisted of morphologically aberrant cells and, as such, were unsuited for wounding assays. A previous screen of NRK cells (Higgins et al., 1991), however, resulted in the derivation of one clone (NRK-R/A) that expressed significantly reduced levels of PAI-1 compared to parental EC-1 cells (Fig. 8). NRK-R/A cells also exhibited a marked inability to close monolayer scrape wounds, although this phenotype was not as severe as in the 4HH derivative and may reflect the fact that, unlike the 4HH clone, NRK-R/A cells express at least some PAI-1 (Fig. 8). Transfection of the NRK-R/A line with the Rc/CMVPAI vector restored both approximately normal levels of PAI-1 synthesis and wound repair ability (Fig. 10).



Fig. 8. Relative PAI-1 protein content in the saponin-resistant fraction of control and transfected NRK cells. Cellular SAP fractions (25,000 cpm trichloroacetic acid-insoluble protein) were separated on SDS/9% acrylamide slab gels. Bands corresponding to actin and the 52-kDa PAI-1 protein are indicated. Compared to parental EC-1 cells and insertless vector-transfected controls (Rc/CMV), de novo synthesized PAI-1 protein was virtually undetectable in an antisense PAI-1-expressing derivative (4HH). The R/A isolate (Higgins et al., 1991), which expresses relatively low levels of PAI-1 protein, is also included for comparison. Although actin and PAI-1 are the predominant protein species resolved, it is apparent that the almost complete loss of and reduction in SAP fraction PAI-1 deposition for the 4HH and R/A cell lines, respectively, is highly specific.

DISCUSSION

In vitro migration into scrape-denuded areas is accomplished by the lateral movement of surviving cells across relatively uncomplicated substrates (e.g., Pepper et al., 1987; Sato and Rifkin, 1988; Ando and Jensen, 1996) unlike in vivo transit through fibrin-rich barriers or a provisional wound matrix (Clark et al., 1995; Yamada and Clark, 1995). Despite these considerable physiologic differences, certain commonalities are evident between the two models. Data presented here indicate that cohorts of migrating and proliferating T2 epithelial cells induced in response to monolayer trauma are, at least initially, spatially as well as temporally distinct. Proliferation is required to maintain the integrity of the migrating front, although inhibition of DNA synthesis (with HU) does not affect cell motility. Similar functional compartmentalization occurs as part of the wound repair response in vivo, suggesting that several important phases of injury resolution (regional PAI-1 expression, spatial/temporal distinctions between the motile and proliferative phenotypes) (e.g., Romer et al., 1991; Pawar et al., 1995; Reidy et al.,

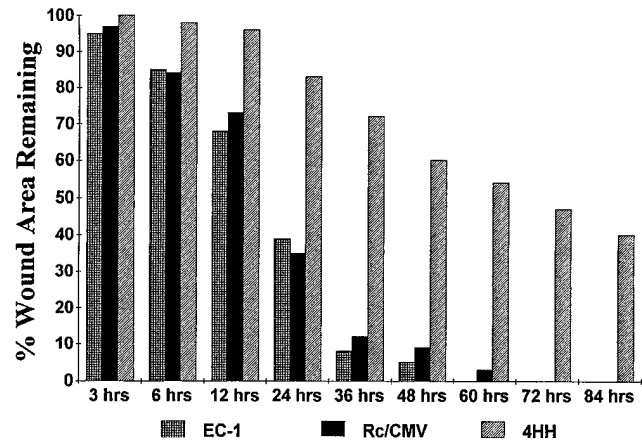

Fig. 9. Kinetics of monolayer scrape wound repair by Rc/CMV/PAI-1-4HH cells compared to parental EC-1 cells and Rc/CMV control transfectants. Confluent monolayers of EC-1, Rc/CMV, and Rc/CMV/PAI-1-4HH cells were maintained in serum-free medium for 3 days, then wounded, and the time course of injury repair assessed as described (Materials and Methods). Whereas the repair rate for EC-1 and Rc/CMV cells was virtually identical, wounds created in monolayers of 4HH cells exhibited little migratory activity and remained open for as long as 84 h postinjury. Data represent the average of duplicate wound repair assays.

1995; Staiano-Coico et al., 1996; Zahm et al., 1997) are recapitulated in the T2 epithelial cell system. Migration may be, in fact, a prerequisite to trauma-associated proliferation as the impaired ability of 4HH cells to heal monolayer wounds was reflected in a substantially reduced number of S-phase or mitotic cells in the 1- to 2-mm region distal to the site of injury (data not shown).

Cycles of (leading edge) adhesion and (trailing edge) detachment must be maintained for cells to locomote effectively; such motile cells utilize focal contact-like structures to form transient attachments with the ECM (e.g., Woods and Couchman, 1988). The levels of cell surface uPA and newly synthesized or matrix-bound PAI-1, therefore, may regulate movement by influencing the extent of disruption of integrin-ECM adhesions (Duband et al., 1991; Okedon et al., 1992; McGuire and Alexander, 1993; Deng et al., 1996; Stefansson and Lawrence, 1996; Blasi, 1997; Chapman, 1997). Subcellular targeting of de novo synthesized PAI-1 to the cellular undersurface in close proximity to focal contact sites (Kutz et al., 1997), moreover, can influence uPA-dependent proteolysis and cell attachment, the latter as a consequence of interactions between the uPA/PAI-1/uPA receptor (uPAR) system and vitronectin or between PAI-1 and vitronectin/ α v integrins (Loskutoff et al., 1999). Indeed, the uPAR associates with β_2/β_1 integrins, binds to vitronectin (Wei et al., 1994, 1996; Bohuslav et al., 1995; Kanse et al., 1996; Chapman, 1997), and focalizes uPA (Wilcox et al., 1997). Vitronectin absorbed from the medium or newly synthesized (Underwood et al., 1993) at the injury site may serve as the initial "matrix" onto which cells adjacent to the wound can migrate.

Binding of vitronectin to the uPAR, and the formation of uPAR-dependent adhesions, requires uPA (Waltz and Chapman, 1994; Wei et al., 1994). Such

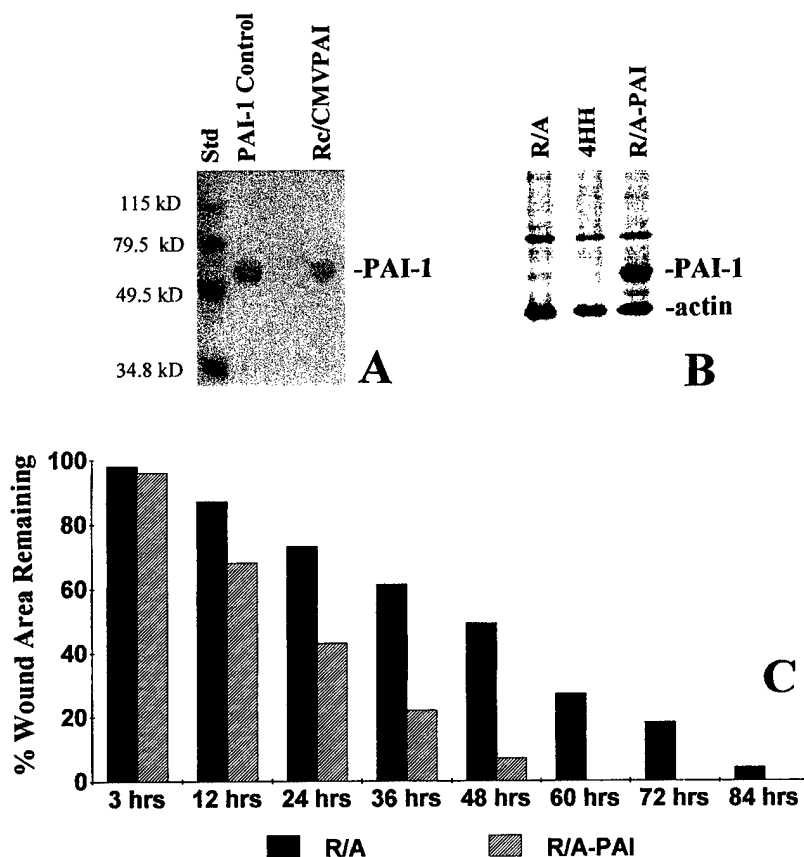

Fig. 10. Effect of vector-driven PAI-1 expression on wound repair by transfectant R/A cells. Coupled *in vitro* transcription/translation assay confirmed that PAI-1 protein was synthesized using the Rc/CMV-PAI vector as template. When the coupled reaction was complete, the translation products were resolved on a SDS/10% acrylamide gel followed by immunoblotting with PAI-1 antibodies (A). Protein standards (Std) and purified PAI-1 protein provided internal controls. Transfection of the Rc/CMVPAI plasmid into R/A cells resulted in derivation of the R/A-PAI line. Gel electrophoresis of the saponin

fraction of ^{35}S -methionine-labeled cultures indicated that SAP fraction PAI-1 protein levels expressed by R/A-PAI cells was greater than 11-fold that of the parental R/A line (B). The time course of wound closure for R/A-PAI transfectants was significantly reduced relative to R/A cells (C), although injury repair by R/A cells (which expressed low levels of PAI-1 compared to EC-1 cells but more PAI-1 than the 4HH derivative; e.g., panel C and Fig. 8) was inhibited relative to EC-1 cells and more effective than 4HH cells (Fig. 9).

uPAR-vitronectin interactions involve the second and third domains of the receptor and are stimulated by pro-PA, uPA, and the isolated A-chain of uPA (Andreasen et al., 1997; Blasi, 1996). PAI-1 binds to the somatomedin B domain of vitronectin, which is the same region that interacts with the uPAR (Deng et al., 1996). The approximately 30-fold greater affinity of PAI-1 for vitronectin, as compared to the affinity of vitronectin for uPAR, suggests a mechanism whereby this SERPIN may effectively dissociate bound vitronectin from uPAR and can detach cells that utilize uPAR as a matrix anchor from a vitronectin substrate (Deng et al., 1996; Loskutoff et al., 1999). Receptor-associated uPA/PAI-1 complexes, moreover, are internalized by endocytosis, which promotes formation of a vacant uPAR on the cell surface by either the internalization of the complex alone or the complex bound to the uPAR followed by receptor recycling (Andreasen et al., 1994, 1997; Blasi, 1996). The available uPAR may bind newly absorbed vitronectin, further supporting adhesive interactions between the cell and the "matrix" to promote lateral migration into the denuded area. Alternatively,

PAI-1 may directly inhibit αv integrin-mediated attachment to vitronectin by blocking accessibility to the RGD sequence located proximal to the uPAR binding site (Stefansson and Lawrence, 1996; Loskutoff et al., 1999).

Wound healing appears to be managed by the temporal induction of genes associated with the plasminogen activation cascade, changes in cellular adhesive characteristics, and by the spatial relationship between surviving cells and their distance from the injury site. Enhanced uPA/plasmin activity is important for cell invasion through complex matrices (Meissauer et al., 1991; Kariko et al., 1993; Stahl and Mueller, 1994; Kawada and Umezawa, 1995; Liu et al., 1995). The requirement for uPA activity to transverse over a substratum, however, is less clear and may be cell type dependent. Although both keratinocytes and endothelial cells express increased levels of uPA and PAI-1 in response to monolayer wounding, uPA is apparently not required for keratinocyte locomotion *in vitro*, whereas occupancy of uPAR by uPA, but not uPA catalytic activity, facilitates wound-responsive endothelial

cell motility (Pepper et al., 1987; Sato and Rifkin, 1988; Okedon et al., 1992; Ando and Jensen, 1996). Present data indicate that PAI-1 expression is an early response to injury and necessary for normal rat kidney-derived epithelial cells to effectively repair monolayer wounds. Since PAI-1 is also critical for invasive growth (Liu et al., 1995; Bajou et al., 1998), the function of PAI-1 in wound repair is likely to be complex. Whether this SERPIN stimulates or inhibits cell motility is likely dependent on both the level and focalization of uPA activity, the composition of the ECM, and the integrin complement of the cell (Kjoller et al., 1997).

These orchestrated events suggest that wounding may be a stimulus that indirectly leads to (genistein-sensitive) signal-transduction events that manage wound healing. In addition to the involvement of local growth factors in cellular reprogramming (e.g., Sato and Rifkin, 1998), uPA binding to its receptor may also transduce signals to the cell interior independent of plasmin generation (Andreasen et al., 1997). uPA-uPAR interactions induce *c-fos* gene expression (Dumler et al., 1994), whereas pro-uPA binding to the u-*PAR* has been reported to inhibit cell cycle progression of HL-60 cells (Howell et al., 1994), explaining, perhaps, the delay in proliferation by cells of the migratory front. The role of uPA in migration across a denuded zone may be cell type related (Pepper et al., 1987; Sato and Rifkin, 1988; Ando and Jensen, 1996) and appears complicated by differential utilization of uPA/uPAR vs. vitronectin/integrin targets as PAI-1-sensitive motors (e.g., Chapman, 1997; Loskutoff et al., 1999). Regardless of the precise mechanism(s) involved, the present findings, using the complementary approaches of molecular genetic targeting of PAI-1 expression and rescue of a repair-deficient phenotype, strongly suggest that PAI-1 regulates renal epithelial cell motility in response to monolayer wounding. The associated changes in the temporal expression and site-specific localization of PAI-1, moreover, would likely influence the stability of both preexisting and newly formed cell-to-ECM adhesive complexes (Ciambrone and McKeown-Longo, 1990), thereby consistently modulating cellular migratory traits over the time course of injury repair (Blasi, 1993, 1996, 1997).

ACKNOWLEDGMENTS

The help of J. Lehman with videomicroscopy and the assistance of M. Ryan and J. Bollenbocker in the generation and analysis of transfectant clones is gratefully acknowledged.

LITERATURE CITED

- Ando Y, Jensen PJ. 1996. Protein kinase C mediates up-regulation of urokinase and its receptor in the migrating keratinocytes of wounded cultures, but urokinase is not required for movement across a substratum in vitro. *J Cell Physiol* 167:500-511.
- Andreasen PA, Scottstrup-Jensen L, Kjoller L, Nykaer A, Moestrup SK, Petersen CM, Gliemann J. 1994. Receptor-mediated endocytosis of plasminogen activators and activator/inhibitor complexes. *FEBS Lett* 338:239-245.
- Andreasen PA, Kjoller L, Christensen L, Duffy MJ. 1997. The urokinase-type plasminogen activator system in cancer metastasis: a review. *Int J Cancer* 72:1-22.
- Bade EG, Feindler S. 1988. Liver epithelial cell migration induced by epidermal growth factor or transforming growth factor alpha is associated with changes in the gene expression of secreted protein. *In Vitro Cell Dev Biol* 24:149-154.
- Bajou K, Noel A, Gerard RD, Masson V, Brunner N, Holst-Hansen C, Skobe M, Fusenig NE, Carmeliet P, Collen D, Foidart JM. 1998. Absence of host plasminogen activator inhibitor 1 prevents cancer invasion and vascularization. *Nat Med* 4:923-928.
- Basile DP, Martin DR, Hammerman MR. 1998. Extracellular matrix-related genes in kidney after ischemic injury: potential role for TGF- β in repair. *Am J Physiol* 275:F894-F903.
- Blasi F. 1993. Urokinase and urokinase receptor: a paracrine/autocrine system regulating cell migration and invasiveness. *Bioessays* 15:105-111.
- Blasi F. 1996. The urokinase receptor and cell migration. *Semin Thromb Hemost* 22:513-516.
- Blasi F. 1997. uPA, uPAR, PAI-1: key intersection of proteolytic, adhesive and chemotactic highways? *Immunol Today* 18:415-417.
- Bohuslav J, Horejsi V, Hansmann C, Stockl J, Weidle UH, Majdic O, Bartke I, Knapp W, Stockinger H. 1995. Urokinase plasminogen activator receptor, beta 2-integrins, and Src-kinases within a single receptor complex of human monocytes. *J Exp Med* 181:1381-1390.
- Carmeliet P, Collen D. 1995. Gene targeting and gene transfer studies of the plasminogen/plasmin system: implications in thrombosis, hemostasis, neointima formation, atherosclerosis. *FASEB J* 9:934-938.
- Carmeliet P, Collen D. 1996. Genetic analysis of the plasminogen and coagulation system in mice. *Haemostasis* 26(Suppl 4):132-150.
- Carmeliet P, Collen D. 1998. Development and disease in proteinase-deficient mice: role of the plasminogen, matrix metalloproteinase and coagulation system. *Thromb Res* 91:255-285.
- Carmeliet P, Moons L, Herbert JM, Crowley J, Lijnen R, Collen D. 1997. Urokinase but not tissue plasminogen activator mediates arterial neointima formation in mice. *Circ Res* 81:829-839.
- Chapman HA. 1997. Plasminogen activators, integrins, the coordinated regulation of cell adhesion and migration. *Curr Opin Cell Biol* 9:714-724.
- Ciambrone GJ, McKeown-Longo PJ. 1990. Plasminogen activator inhibitor type 1 stabilizes vitronectin-dependent adhesions in HT-1080 cells. *J Cell Biol* 111:2183-2195.
- Clark RAF. 1995. Wound repair: overview and general considerations. In: Clark RAF, editor. *The molecular and cellular biology of wound repair*. New York: Plenum Press. p 3-50.
- Dano K, Andreasen PA, Grondahl-Hansen J, Kristensen P, Nielsen LS, Skriver L. 1985. Plasminogen activators, tissue degradation, and cancer. *Adv Cancer Res* 44:139-266.
- Declercq PJ, De Mol M, Alessi MC, Baudner S, Paques EP, Preissner KT, Muller-Berghaus G, Collen D. 1988. Purification and characterization of a plasminogen activator inhibitor 1 binding protein from human plasma: identification as a multimeric form of S protein (vitronectin). *J Biol Chem* 263:15454-15461.
- Deng G, Curriden SA, Wang S, Rosenberg S, Loskutoff DJ. 1996. Is plasminogen activator inhibitor-1 the molecular switch that governs urokinase receptor-mediated cell adhesion and release? *J Cell Biol* 134:1563-1571.
- Duband JL, Dufour S, Yamada SS, Yamada KM, Thiery JP. 1991. Neural crest cell locomotion induced by antibodies to beta 1 integrins: a tool for studying the roles of substratum molecular avidity and density in migration. *J Cell Sci* 98:517-532.
- Dumler I, Petri T, Schleuning WD. 1994. Induction of *c-fos* gene expression by urokinase-type plasminogen activator in human ovarian cancer cells. *FEBS Lett* 343:103-106.
- Ellis V, Wun TC, Behrendt N, Ronne E, Dano K. 1990. Inhibition of receptor-bound urokinase by plasminogen-activator inhibitors. *J Biol Chem* 265:9904-9908.
- Fotsis T, Pepper M, Adlercreutz H, Fleischmann G, Hase T, Montesano R, Schweigerer L. 1993. Genistein, a dietary-derived inhibitor of in vitro angiogenesis. *Proc Natl Acad Sci USA* 90:2690-2694.
- Grimaldi G, DiFiore P, Locatelli EK, Falco J, Blasi F. 1986. Modulation of urokinase plasminogen activator gene expression during the transition from quiescent to proliferative state in normal mouse cells. *EMBO J* 5:855-861.
- Guadagno TM, Assoian RK. 1991. G₁/S control of anchorage-dependent growth in the fibroblast cell cycle. *J Cell Biol* 115:1419-1452.
- Guadagno TM, Ohtsubo M, Roberts JM, Assoian RK. 1993. A link between cyclin A expression and adhesion-dependent cell cycle progression. *Science* 262:1572-1575.
- Hasenstab D, Forough R, Clowes AW. 1997. Plasminogen activator inhibitor type 1 and tissue inhibitor of metalloproteinases-2 increase after arterial injury in rats. *Circ Res* 80:490-496.
- Hawks K, Higgins PJ. 1998. Cell shape-dependent pathway of plas-

- minogen activate inhibitor type-1 gene expression requires cytoskeletal reorganization. *J Cell Physiol* 176:293-302.
- Higgins PJ, Ryan MP. 1992. Identification of the 52 kDa cytoskeletal protein of cytochalasin D-stimulated normal rat kidney (NRK/CD) cells as substrate-associated glycoprotein p52 [plasminogen-activator inhibitor type-1 (PAI-1)]: expression of p52(PAI-1) in NRK/CD cells is regulated at the level of mRNA abundance. *Biochem J* 284:433-439.
- Higgins PJ, Ryan MP, Chaudhari P. 1989. Cytochalasin D-mediated hyperinduction of the substrate-associated 52-kilodalton protein p52 in rat kidney fibroblasts. *J Cell Physiol* 139:407-417.
- Higgins PJ, Ryan MP, Zeheb R, Gelehrter TD, Chaudhari P. 1990. p52 induction by cytochalasin D in rat kidney fibroblasts: homologies between p52 and plasminogen activator inhibitor type-1. *J Cell Physiol* 143:321-329.
- Higgins PJ, Chaudhari P, Ryan MP. 1991. Cell shape regulation and matrix protein p52 content in phenotypic variants of ras-transformed rat kidney fibroblasts. *Biochem J* 273:651-658.
- Higgins PJ, Ryan MP, Providence KM. 1994. Induced expression of p52(PAI-1) in normal rat kidney cells by the microfilament-disrupting agent cytochalasin D. *J Cell Physiol* 159:187-195.
- Higgins PJ, Ryan MP, Jelley DM. 1997. p52^{PAI-1} gene expression in butyrate-induced flat revertants of v-ras-transformed rat kidney cells: mechanism of induction and involvement in the morphological response. *Biochem J* 321:431-437.
- Howell AL, Hunt JA, James TW, Mazar A, Henkin J, Zacharski LR. 1994. Urokinase inhibits HL-60 cell proliferation *in vitro*. *Blood Coagul Fibrinolysis* 5:445-453.
- Jensen PJ, Lavker RM. 1996. Modulation of the plasminogen activator cascade during enhanced epidermal proliferation *in vivo*. *Cell Growth Differ* 7:1793-1804.
- Kanse SM, Kost C, Wilhelm OG, Andreasen PA, Preissner KT. 1996. The urokinase receptor is a major vitronectin-binding protein on endothelial cells. *Exp Cell Res* 224:344-353.
- Kariko K, Kuo A, Boyd D, Okada S, Cines DB, Barnathan ES. 1993. Overexpression of urokinase receptor increases matrix invasion without altering cell migration in a human osteosarcoma cell line. *Cancer Res* 53:3109-3117.
- Kawada M, Umezawa K. 1995. Suppression of *in vitro* invasion of human fibrosarcoma cells by a leupeptin analogue inhibits the urokinase-plasmin system. *Biochem Biophys Res Commun* 209:25-30.
- Kjoller L, Kanse SM, Kirkegaard T, Rodenburg KW, Ronne E, Goodman SL, Preissner KT, Ossowski L, Andreasen PA. 1997. Plasminogen activator inhibitor-1 represses integrin- and vitronectin-mediated cell migration independently of its function as an inhibitor of plasminogen activation. *Exp Cell Res* 232:420-429.
- Krakoff IH, Brown NC, Reichard P. 1968. Inhibition of ribonucleotide diphosphate reductase by hydroxurea. *Cancer Res* 28:1559-1565.
- Kutz SM, Nickey S, White LA, Higgins PJ. 1997. Induced PAI-1 mRNA expression and targeted protein accumulation are early G₁ events in serum-stimulated rat kidney cells. *J Cell Physiol* 170:8-18.
- Laiho M, Keski-Oja J. 1989. Growth factors in the regulation of pericellular proteolysis: a review. *Cancer Res* 49:2533-2553.
- Ledger PW, Uchida N, Tanzer ML. 1980. Immunocytochemical localization of procollagen and fibronectin in human fibroblasts: effects of the monovalent ionophore, monensin. *J Cell Biol* 87:663-671.
- Liu G, Shuman MA, Cohen RL. 1995. Co-expression of urokinase, urokinase receptor and PAI-1 is necessary for optimum invasion of cultured lung cancer cells. *Int J Cancer* 60:501-506.
- Loskutoff DJ, Curriden SA, Hu G, Deng G. 1999. Regulation of cell adhesion by PAI-1. *APMIS* 107:54-61.
- McGuire PG, Alexander SM. 1993. Inhibition of urokinase synthesis and cell surface binding alters the motile behavior of embryonic endocardial-derived mesenchymal cells *in vitro*. *Development* 118:931-939.
- Meissauer A, Kramer MD, Hofmann M, Erkell LJ, Jacob E, Schirrmacher V, Brunner G. 1991. Urokinase-type and tissue-type plasminogen activators are essential for *in vitro* invasion of human melanoma cells. *Exp Cell Res* 192:453-459.
- Mimuro J, Loskutoff DJ. 1989a. Binding of type 1 plasminogen activator inhibitor to the extracellular matrix of cultured bovine endothelial cells. *J Biol Chem* 264:5058-5063.
- Mimuro J, Loskutoff DJ. 1989b. Purification of a protein from bovine plasma that binds to type 1 plasminogen activator inhibitor and prevents its interaction with extracellular matrix: evidence that the protein is vitronectin. *J Biol Chem* 264:936-939.
- Mu XC, Staiano-Coico L, Higgins PJ. 1998. Increased transcription and modified growth state-dependent expression of the plasminogen activator inhibitor type-1 gene characterize the senescent phenotype in human diploid fibroblasts. *J Cell Physiol* 174:90-98.
- Okada SS, Tomaszewski JE, Barnathan ES. 1995. Migrating vascular smooth muscle cells polarize cell surface urokinase receptor after injury *in vitro*. *Exp Cell Res* 217:180-187.
- Okedon LE, Sato Y, Rifkin DB. 1992. Urokinase-type plasminogen activator mediates basic fibroblast growth factor-induced bovine endothelial migration independent of its proteolytic activity. *J Cell Physiol* 150:258-263.
- Pappot H, Gardsvoll H, Romer J, Pedersen AN, Grondahl-Hansen J, Pyke C, Brunner N. 1995. Plasminogen activator inhibitor type 1 in cancer: therapeutic and prognostic implications. *J Biol Chem* 376:259-267.
- Pawar S, Kartha S, Toback FG. 1995. Differential gene expression in migrating renal epithelial cells after wounding. *J Cell Physiol* 165:556-565.
- Pepper MS, Vassalli JD, Montesano R, Orci L. 1987. Urokinase-type plasminogen activator is induced in migrating capillary endothelial cells. *J Cell Biol* 105:2535-2541.
- Pepper MS, Sappino AP, Montesano R, Orci L, Vassalli JD. 1992. Plasminogen activator inhibitor-1 is induced in migrating endothelial cells. *J Cell Physiol* 153:129-139.
- Pepper MS, Sappino AP, Stocklin R, Montesano R, Orci L, Vassalli JD. 1993. Upregulation of urokinase receptor expression on migrating endothelial cells. *J Cell Biol* 122:673-684.
- Pilcher BK, Dumin JA, Sudbeck BD, Krane SM, Welgus HG, Parks WC. 1997. The activity of collagenase-1 is required for keratinocyte migration on a type I collagen matrix. *J Cell Biol* 137:1445-1457.
- Planus E, Barlovatz-Mermon G, Rodgers RA, Bonavaud S, Ingber DE, Wang N. 1997. Binding of urokinase to plasminogen activator inhibitor type-1 mediates cell adhesion and spreading. *J Cell Sci* 110:1091-1098.
- Pollanen J, Saksela O, Salonen EM, Andreasen P, Neilsen L, Dano K, Vaheri A. 1987. Distinct localization of urokinase-type plasminogen activator and its type-1 inhibitor under cultured human fibroblasts and sarcoma cells. *J Cell Biol* 104:1085-1096.
- Pollanen J, Ross W, Vaheri A. 1991. Directed plasminogen activation at the surface of normal and transformed cells. *Adv Cancer Res* 57:273-328.
- Reidy M, Irwin C, Lindner V. 1995. Migration of arterial wall cells. *Circ Res* 78:405-414.
- Romer J, Lund LR, Eriksen J, Ralfkiaer E, Zeheb R, Gelehrter TD, Dano K, Kristensen P. 1991. Differential expression of urokinase-type plasminogen activator and its type-1 inhibitor during healing of mouse skin wounds. *J Invest Dermatol* 97:803-811.
- Romer J, Bugge TH, Pyke C, Lund LR, Flick MJ, Degen JL, Dano K. 1996. Impaired wound healing in mice with a disrupted plasminogen gene. *Nat Med* 2:287-292.
- Ryan MP, Higgins PJ. 1988. Cytoarchitecture of Kirsten sarcoma virus-transformed rat kidney fibroblasts: butyrate-induced reorganization within the actin microfilament network. *J Cell Physiol* 137:25-34.
- Ryan MP, Higgins PJ. 1993. Growth state-regulated expression of p52(PAI-1) in normal rat kidney cells. *J Cell Physiol* 155:376-384.
- Ryan MP, Kutz SM, Higgins PJ. 1996. Complex regulation of plasminogen activator inhibitor type-1 (PAI-1) gene expression by serum and substrate adhesion. *Biochem J* 314:1041-1046.
- Sato Y, Rifkin DB. 1988. Autocrine activities of basic fibroblast growth factor: regulation of endothelial cell movement, plasminogen activator synthesis, and DNA synthesis. *J Cell Biol* 107:1199-1205.
- Schafer BM, Maier K, Eickhoff U, Todd RF, Kramer MD. 1994. Plasminogen activation in healing human wounds. *Am J Pathol* 144:1269-1280.
- Schneiderman J, Sawdey M, Craig H, Thinnis T, Bordui G, Loskutoff DJ. 1993. Type 1 plasminogen activator inhibitor gene expression following partial hepatectomy. *Am J Pathol* 143:753-762.
- Seiffert D, Mimuro J, Schleeff RR, Loskutoff DJ. 1990. Interactions between type 1 plasminogen activator inhibitor, extracellular matrix and vitronectin. *Cell Differ Dev* 32:287-292.
- Smith TJ, Ahmed A, Hogg MG, Higgins PJ. 1992. Interferon-gamma is an inducer of plasminogen activator inhibitor type 1 in human orbital fibroblasts. *Am J Physiol* 263:C24-C29.
- Stahl A, Mueller BM. 1994. Binding of urokinase to its receptor promotes migration and invasion of human melanoma cells *in vitro*. *Cancer Res* 54:3066-3071.
- Staiano-Coico I, Carano K, Allan VM, Steiner MG, Pagan-Charry I, Bailey BB, Babaar P, Rigas B, Higgins PJ. 1996. PAI-1 gene expression is growth state-regulated in cultured human epidermal keratinocytes during progression to confluence and postwounding. *Exp Cell Res* 227:123-134.
- Stefansson S, Lawrence DA. 1996. The serpin PAI-1 inhibits cell migration by blocking integrin $\alpha\beta 5$ binding to vitronectin. *Nature* 383:441-443.

- Thornton AJ, Bruzdinski CJ, Raper SE, Gelehrter TD. 1994. Plasminogen activator inhibitor-1 is an immediate early response gene in regenerating rat liver. *Cancer Res* 54:1337-1343.
- Uchida N, Smilowitz H, Ledger PW, Tanzer ML. 1980. Kinetic studies of the intracellular transport of procollagen and fibronectin in human fibroblasts: effects of the monovalent ionophore, monensin. *J Biol Chem* 255:8638-8644.
- Underwood PA, Steele JG, Dalton BA. 1993. Effects of polystyrene surface chemistry on the biological activity of solid phase fibronectin and vitronectin, analyzed with monoclonal antibodies. *J Cell Sci* 104:793-803.
- Uno S, Nakamura M, Seki T, Ariga T. 1997. Induction of tissue-type plasminogen activator (tPA) and type-1 plasminogen activator inhibitor (PAI-1) as early growth responses in rat hepatocytes in primary culture. *Biochem Biophys Res Commun* 239:123-128.
- Vassalli JD, Sappino AP, Belin D. 1991. The plasminogen activator/plasmin system. *J Clin Invest* 88:1067-1072.
- Wallin A, Zhang G, Jones TW, Jaken S, Stevens JL. 1992. Mechanisms of the nephrogenic repair process: studies on proliferation and vimentin expression after ³⁵S-1,2-dichlorovinyl-L-cysteine nephrotoxicity in vivo and in cultured proximal tubule epithelial cells. *Lab Invest* 66:474-484.
- Waltz DA, Natkin LR, Fujita RM, Wei Y, Chapman HA. 1997. Plasmin and plasminogen activator inhibitor type-1 promote cellular motility by regulating the interaction between the urokinase receptor and vitronectin. *J Clin Invest* 100:58-67.
- Wang PJ, Chabes A, Casagrande R, Tian XC, Thelander L, Huffaker TC. 1997. Rnr4p, a novel ribonucleotide reductase small-subunit protein. *Mol Cell Biol* 17:6114-6121.
- Wei Y, Waltz DA, Rao N, Drummond RJ, Rosenberg S, Chapman HA. 1994. Identification of the urokinase receptor as an adhesion receptor for vitronectin. *J Biol Chem* 269:32380-32388.
- Wei Y, Lukashev M, Simon DI, Bodary SC, Rosenberg S, Doyle MV, Chapman HA. 1996. Regulation of integrin function by the urokinase receptor. *Science* 273:1551-1555.
- White LA, Bruzdinski C, Gelehrter TD, Higgins PJ. 1999. Transcriptional regulation of plasminogen activator inhibitor type-1 gene expression in renal epithelial cells by a proximal promoter E box element. *J Cell Physiol* (in press).
- Wilcox SA, Reho T, Higgins PJ, Tominna-Sebald E, McKeown-Longo PJ. 1996. Localization of urokinase to focal adhesions by human fibrosarcoma cells synthesizing recombinant vitronectin. *Biochem Cell Biol* 74:899-910.
- Woods A, Couchman JR. 1988. Focal adhesions and cell-matrix interactions. *Cell Relat Res* 8:155-182.
- Yamada KM, Clark RAF. 1995. Provisional matrix. In: Clark RAF, editor. *The molecular and cellular biology of wound repair*. New York: Plenum Press. p 51-93.
- Zahm JM, Kaplan H, Herard AL, Doriot F, Pierrot D, Somelette P, Puchelle E. 1997. Cell migration and proliferation during the in vitro wound repair of the respiratory epithelium. *Cell Motil Cytoskeleton* 37:33-43.