

REPORT DOCUMENTATION PAGE

AFRL-SR-BL-TR-01-

Public reporting burden for this collection of information is estimated to average 1 hour per response, including gathering and maintaining the data needed, and completing and reviewing the collection of information. Send collection of information, including suggestions for reducing this burden, to Washington Headquarters Service, Room 1224, 4800 Marking Drive, Arlington, VA 22204-4302, and to the Office of Management and Budget, Paperwork Project (0307), Washington, DC 20503.

Source,
of this
afferson

0307

1. AGENCY USE ONLY (Leave Blank)	2. REPORT DATE 02/20/01	3. REPORT TYPE AND DATES COVERED Final Technical Report - 19950315-19981130		
4. TITLE AND SUBTITLE Smart Pixels for Image Computing		5. FUNDING NUMBERS F49620-95-1-0257		
6. AUTHORS Fouad E. Kiamilev, Associate Professor, University Of Delaware 140 Evans Hall Newark, DE 19716 Tel: 302-831-8969, Fax: 302-831-4617		8. PERFORMING ORGANIZATION REPORT NUMBER 2975-95-0018		
7. PERFORMING ORGANIZATION NAME(S) AND ADDRESS(ES) The University of North Carolina at Charlotte Office of Research Services 9201 University City Boulevard Charlotte, NC 28262		10. SPONSORING/MONITORING AGENCY REPORT NUMBER		
9. SPONSORING / MONITORING AGENCY NAME(S) AND ADDRESS(ES) AFOSR/NE 801 North Randolph Street, Room 732 Arlington, VA 22203-1977		11. SUPPLEMENTARY NOTES		
12a. DISTRIBUTION / AVAILABILITY STATEMENT APPROVED FOR RELEASE, DISTRIBUTION STATEMENTS		12b. DISTRIBUTION CODE		
13. ABSTRACT (Maximum 200 words) The goal of our research effort is to study the use of smart pixel technology for image processing applications. The effort consists of five inter-related projects in the following areas: 1. Architecture and system design studies for image processing using smart pixels. 2. Comparison of smart pixel approach with competing electronic solutions. 3. Design, fabrication and test of smart pixel chipsets for image computing. 4. Collaboration with system groups to insert our chipsets into system prototypes. 5. Collaboration with a leading supplier of integrated circuit (IC) design tools to adapt their software for design of smart pixel ICs.				
17. SECURITY CLASSIFICATION OF REPORT Unclassified		18. SECURITY CLASSIFICATION OF THIS PAGE Unclassified	19. SECURITY CLASSIFICATION OF ABSTRACT Unclassified	20. LIMITATION OF ABSTRACT UL
15. NUMBER OF PAGES 17			16. PRICE CODE N/A	

NSN 7540-01-280-5500

Standard Form 298 (Rev. 2-89)
Prescribed by ANSI Std. Z39-1
298-102

20010514 091

Final Report

Principal Investigator

Dr. Fouad Kiamilev
Associate Professor of Electrical Engineering

Funded Institution:

Department of Electrical Engineering
University of North Carolina at Charlotte
Charlotte, NC 28223

AFOSR Grant #:

F49620-95-1-0257

Program Title:

SMART PIXELS FOR IMAGE COMPUTING

Contract Period:

01 Jan. 95 (36 Months)

Funding:

\$344,705

1.1. Executive Summary

The goal of our research effort is to study the use of smart pixel technology for image processing applications. The effort consists of five inter-related projects in the following areas:

1. Architecture and system design studies for image processing using smart pixels.
2. Comparison of smart pixel approach with competing electronic solutions.
3. Design, fabrication and test of smart pixel chipsets for image computing.
4. Collaboration with system groups to insert our chipsets into system prototypes.
5. Collaboration with a leading supplier of integrated circuit (IC) design tools to adapt their software for design of smart pixel ICs.

1.2. Accomplishments/New Findings

Photonic FFT Processor Architecture - We have designed a high-performance photonic chipset for computing 1-D complex fast-Fourier transforms (FFT). The Fast-Fourier Transform (FFT) is an important operation for many applications such as image processing, high-speed control, and instrumentation. Our design is based on the hybrid CMOS-SEED technology. The performance benchmarks show our design to be significantly faster than current electronic implementations. Specifically, we can compute a new 1,024-point complex FFT in every 0.44 μ sec using a fully pipelined system with 21 OEIC chips. A high-performance electronic system that uses 4 Sharp LH9124 FFT processor chips, 12 Sharp LH9320 address generator chips, 12 SRAM chips, and various glue-logic chips requires 31 μ sec for the same computation.

Fine-Grain Multiprocessor OEIC - We have designed and fabricated a hybrid CMOS-SEED IC that integrates 512 bit-serial processors. Our design is targeted toward image processing applications such as template matching that require large number of bit-serial operations. The chip integrates approximately 400,000 MOS transistors and 4,096 optical I/O. Each processor contains a Logic-Only Unit (LOU), 100 bits of RAM, and a single high-speed

register. The LOU circuit is capable of computing any two-bit logic function in a single clock cycle. At 100MHz clock speed, this chip will achieve 51.2 Billion 1-bit operations per second. On chip electrical interconnection network provides near-neighbor connections between processors. Global interconnections are to be implemented optically using free-space optical interconnects. This device has been fabricated and initial optical tests at Lucent show correct operation.

Coarse-Grain Multiprocessor OEIC - We have designed and fabricated a 64-bit microprocessor core IC with 192 optical I/O. Our design is targeted toward image processing applications requiring bit-parallel computations. This 3.5mm² hybrid CMOS-SEED IC was electrically tested at 100MHz with a performance of 100 million 64-bit instructions per second (MIPS). The processor design includes a 64-bit arithmetic logic unit (ALU) which implements 16 logic and 32 arithmetic functions. A 1cm² chip can integrate thirty two 64-bit processors and achieve 3,200 64-bit MIPS. Further performance improvements can be achieved using a 0.35 micron CMOS process. When combined with an appropriate photonic page buffer IC operating as cache memory, it becomes possible to build a compact, two-chip parallel processor system. We have optically tested this chipset at Optivision to verify correct operation at low speed.

Multiprocessor Switch OEIC - We have collaborated with Lucent Technologies to design, fabricate and test a 16-channel, 16-bits/channel self-routing crossbar OEIC for multiprocessor switching. This chip integrates 120,000 MOS transistors with an array of 4,096 optical devices. The device has been optically tested at Lucent operating at 50MHz clock rate. A novel approach taken in this project by Lucent is to use WDM technology to wavelength-multiplex 16-bits of each channel onto a single fiber.

Photonic Page Buffer Chipsets - We have designed, fabricated and tested 6 OEICs for optical memory applications. Our chip technology, called the hybrid CMOS-SEED, is based on flip-chip integration of submicron CMOS ICs with GaAs chips containing 2-D arrays of multiple-quantum wells (MQW) diode optical receivers and transmitters. The largest OEIC was designed jointly with Lucent Technologies and it integrates 50Kbits of static RAM (approximately 400,000 MOS transistors) with 4,096 optical devices. The memory is organized as a 512-bit wide and 100-bit deep random access memory with 512 logic-only units (LOUs) processors. The LOUs allow this device to perform high-speed image and data processing algorithms. This device has been fabricated and initial tests show correct operation. Earlier, we have collaborated with Lucent Technologies to demonstrate a 2Kbit (21,000 MOS transistors) photonic page buffer IC. The 64 optical I/O channels on this IC were tested at 50Mbps/channel optical data throughput. We have successfully applied our work to a DARPA funded program at Optivision. There we have designed a 32-channel, 128-bit photonic page buffer OEIC that was tested by Optivision for parallel optical operation at 277MHz.

High-Performance Test Fixture for OEICs - We have built a compact, 84 I/O channel, 100 Mbps/channel test fixture for testing and control of optoelectronic integrated circuits (OEICs). We have used this fixture to test over a dozen OEIC that were designed under this program. We have successfully transitioned this work to Hewlett-Packard into a DARPA funded program on parallel optical links (Darpa Polo Project, Darpa PM: Anis Hussain). Our fixture is

also being used at Lucent Technologies and we are in the process of delivering a version to UCSD (Dr. Shaya Fainman).

1.3. Personnel Supported

Richard Rozier - Ph.D. student in the department of Electrical Engineering at UNCC. Mr. Rozier is a United States citizen. He is funded from a related AASERT (F49620-95-1-0425).

James Rorie - Ph.D. student in the department of Electrical Engineering at UNCC. Mr. Rorie is a United States citizen. He is funded from a related AASERT (F49620-95-1-0425).

Jason Lambirth - M.S.E.E. student in the department of Electrical Engineering at UNCC. Mr. Lambirth is a United States citizen.

Dr. Fouad Kiamilev - Asst. Professor of Electrical Engineering at UNCC. Dr. Kiamilev is a research advisor for all of the above students.

Dr. Ashok Krishnamoorthy - Member of Technical Staff, AT&T Bell Laboratories. Dr. Krishnamoorthy is involved in jointly advising Dr. Kiamilev's students.

1.4. Publications

1. A. V. Krishnamoorthy, J. E. Ford, K. W. Goossen, A. L. Lentine, S. P. Hui, B. Tseng, L. M. F. Chirovsky, R. Leibenguth, D. Kossives, D. Dahringer, L. A. D'Asaro, F. E. Kiamilev, G. F. Aplin, R. G. Rozier, and D. A. B. Miller Photonic Page Buffer based on GaAs MQW modulators bonded directly over active silicon CMOS circuits, Applied Optics, Vol. 35, No. 14, pp. 2439-2448, May 1996.
2. A.V. Krishnamoorthy, T.K. Woodward, R.A. Novotny, K.W. Goosen, J.A. Walker, A.L. Lentine, L.A. D'Asaro, S.P. Hui, B. Tseng, R. Leibenguth, D. Kossives, D. Dahringer, L.M.F. Chirovsky, G.F. Aplin, R.G. Rozier, F.E. Kiamilev, and D.A.B. Miller, Ring Oscillators with Optical and Electrical Readout based on Hybrid GaAs MQW Modulators Bonded to 0.8micron Silicon VLSI Circuits, Electronic Letters, Vol. 31, No. 22, pages 1917-1918, October 1995.
3. A.V. Krishnamoorthy, A.L. Lentine, K.W. Goosen, J.A. Walker, T.K. Woodward, J.E. Ford, G.F. Aplin, L.A. D'Asaro, S.P. Hui, B. Tseng, R. Leibenguth, D. Kossives, L.M.F. Chirovsky, and D.A.B. Miller, "3-D Integration of MQW Modulators over Active Sub-micron CMOS Circuits: 375Mb/s Transimpedance Receiver-Transmitter Circuit," IEEE Photonics Technology Letters, June 1995.
4. R.G. Rozier, F.E. Kiamilev and A.V. Krishnamoorthy, Design and Evaluation of a Photonic FFT Processor, submitted to the Journal of Parallel and Distributed Computing (JPDC) for Special Issue on Parallel Computing with Optical Interconnections, December 1995.
5. F.E. Kiamilev, R.G. Rozier, J.E. Rieve, and A.V. Krishnamoorthy, Design of Large-Scale Photonic Page Buffer ICs, to be submitted to Special Issue on Smart Pixels, International Journal of Optoelectronics, August 1996.
6. A.V. Krishnamoorthy, T.K. Woodward, K.W. Goosen, J.A. Walker, S.P. Hui, B. Tseng, J.E. Cunningham, W.Y. Jan, F. Kiamilev and D.A.B. Miller, A Dual-Function Detector/Modulator Smart-Pixel Module, submitted to Applied Optics, June 1996.
7. A.V. Krishnamoorthy, J.E. Ford, K.W. Goosen, J.A. Walker, A.L. Lentine, L.A. D'Asaro, S.P. Hui, B. Tseng, R. Leibenguth, D. Kossives, D. Dahringer, L.M.F. Chirovsky, F.E. Kiamilev, G.F. Aplin, R.G. Rozier and D.A.B. Miller, Implementation of a Photonic Page Buffer Based on GaAs MQW Modulators Bonded Directly over Active Silicon VLSI Circuits, in Proc. OSA Topical Meeting on Optical Computing, Salt Lake City, Paper OTuD2 (postdeadline), March 1995.
8. A.V. Krishnamoorthy and F.E. Kiamilev, Fanout, Replication and Buffer Sizing for a Class of Self-Routing Packet-Switched Multistage Photonic Switch Fabrics, in Proceedings of OSA Topical Meeting on Photonic Switching, Salt Lake City, page 87, March 1995.

9. A.V. Krishnamoorthy, J.E. Ford, K.W. Goosen, J.A. Walker, A.L. Lentine, T.K. Woodward, L.A. D'Asaro, S.P. Hui, B. Tseng, R. Leibenguth, D. Kossives, D. Dahringer, L.M.F. Chirovsky, F.E. Kiamilev, G.F. Aplin, R.G. Rozier and D.A.B. Miller, 3-D Integration of MQW SEED Detectors and Modulators over Active Sub-micron CMOS circuits: Application to a 2kbit Parallel Photonic Page Buffer, in Proc. LEOS Annual Meeting, Optical Interconnects and Processing Systems, San Francisco, October 1995.
10. J.E. Ford, A.V. Krishnamoorthy, K.W. Goosen, J.A. Walker, D.A.B. Miller, R. Morrison, A.L. Lentine, S.P. Hui, B. Tseng, L.M.F. Chirovsky, R. Leibenguth, D. Kossives, D. Dahringer, L.A. D'Asaro, G.F. Aplin, R.G. Rozier and F.E. Kiamilev, Optical Test of an Photonic FIFO Page Buffer Memory, in Proc. OE/LASE'96 Conference on Optoelectronic Interconnects and Modules, San Jose, CA 1996.
11. F.E. Kiamilev, R.G. Rozier, and J.L. Rieve, "A compact, low-cost, high-performance test fixture for electrical test and control of smart pixel ICs," in Proc. 1996 IEEE/LEOS Summer Topical Meeting on Smart Pixels, Keystone, CO (August 5-9, 1996).
12. R.G. Rozier, F.E. Kiamilev and A.V. Krishnamoorthy, "Design and evaluation of a photonic FFT processor," in Proc. 1996 IEEE/LEOS Summer Topical Meeting on Smart Pixels, Keystone, CO (August 5-9, 1996).
13. K.K. Chau, M.W. Derstine, S. Wakelin, J. Cloonan, F.E. Kiamilev, and A.V. Krishnamoorthy, "High speed serial and parallel access memory smart pixel," in Proc. 1996 IEEE/LEOS Summer Topical Meeting on Smart Pixels, Keystone, CO (August 5-9, 1996).
14. F.E. Kiamilev, R.G. Rozier, J.L. Rieve and A.V. Krishnamoorthy, "Design of large-scale photonic page buffer ICs," in Proc. 1996 IEEE/LEOS Summer Topical Meeting on Smart Pixels, Keystone, CO (August 5-9, 1996).
15. A.V. Krishnamoorthy, J.E. Ford, K.W. Goosen, J.A. Walker, B. Tseng, S.P. Hui, J.E. Cunningham, W.Y. Tan, T.K. Woodward, R.G. Rozier, and D.A.B. Miller, "Fabrication and testing of AMOEBA: an optoelectronic switch for multiprocessor networking," in Proc. 1996 IEEE/LEOS Summer Topical Meeting on Smart Pixels, Keystone, CO (August 5-9, 1996).
16. R.G. Rozier, F.E. Kiamilev, and A.V. Krishnamoorthy, "Design of a parallel photonic FFT processor," accepted in 1996 IEEE MPPOI Conference, Maui, HI (October 23-24, 1996).
17. A.V. Krishnamoorthy, J.E. Ford, K.W. Goosen, J.A. Walker, B. Tseng, S.P. Hui, J.E. Cunningham, W.Y. Jan, T.K. Woodward, M.C. Nuss, R.G. Rozier, F.E. Kiamilev, and D.A.B. Miller, "The AMOEBA chip: an opto-electronic switch for multiprocessor networking using dense WDM," accepted in 1996 IEEE MPPOI Conference, Maui, HI (October 23-24, 1996).
18. F.E. Kiamilev, J.S. Lambirth, R.G. Rozier, and A.V. Krishnamoorthy, "Design of a 64-bit microprocessor core IC for hybrid CMOS-SEED technology," accepted in 1996 IEEE MPPOI Conference, Maui, HI (October 23-24, 1996).
19. R.G. Rozier and F.E. Kiamilev, "Design of MCM-based FFT processor," submitted to IEEE Multi-Chip Module Conference, Santa Cruz, CA (February 4-5, 1997).
20. F.E. Kiamilev, R.G. Rozier, A.V. Krishnamoorthy, J.E. Rieve, C.D. Hull, R. Farbarik, R.E. Oettel, G.F. Aplin, "Design of integrated circuits with flip-chip attachment to optoelectronic device arrays," submitted to IEEE Multi-Chip Module Conference, Santa Cruz, CA (February 4-5, 1997).

1.5. Chipset Development

Free-space optical interconnection (FSOI) of integrated circuits, called smart pixels, shows great potential for efficient implementation of high-performance parallel computing systems [1]. The use of FSOI technology to build massively parallel processors (MPPs) has been previously proposed [2,3]. In this approach, large numbers of simple, bit-serial processors are integrated on a single chip and interconnected using FSOI. While this architecture is

efficient for bit-oriented logic calculations, it requires multiple-clock cycles to complete arithmetic and logic operations that involve multiple bits. An alternative approach is to use a more sophisticated processor design capable of operating on multiple-bits in a single clock-cycle. While fewer such processors can be integrated on a single chip, the aggregate performance of this approach can potentially exceed the performance of the bit-serial approach for certain computations. The purpose of this study is to investigate the design of such a bit-parallel processor using smart pixel technology.

In this paper, we present the design of a hybrid CMOS-SEED 64-bit microprocessor core integrated circuit (IC). This 3.5mm^2 IC was fabricated in 0.8 micron HP26G CMOS technology [4] and integrates approximately 12,000 MOS transistors. Functionally, the design integrates a 64-bit electrically scanable register (ESR) and a 64-bit arithmetic-logic unit (ALU) that provides a full range of boolean and arithmetic functions. The chip contains 128 optical receiver circuits and 64 optical transmitter circuits, and was electrically tested at 100MHz with a performance of 100 million 64-bit instructions per second (MIPS). The processor is designed to optically input two 64-bit words and optically output one 64-bit word on every clock cycle. The clock and control signals are supplied to the chip electrically. Figure 1 shows the chip layout.

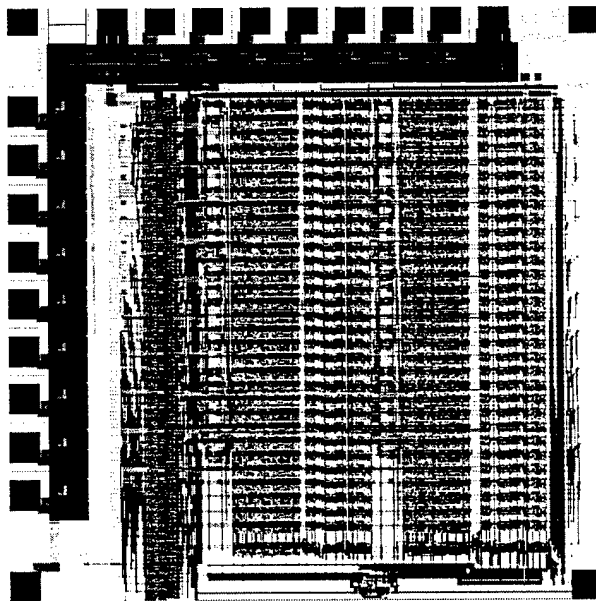

Figure 1. Layout of the 64-bit microprocessor core IC for hybrid CMOS-SEED technology.

Our chip was designed to mate with a proven GaAs diode array based on the hybrid CMOS-SEED technology [5] that enables GaAs MQW photodetectors and modulators to be flip-chip bonded to commodity CMOS VLSI processes. It was fabricated as part of the 1995 AT&T-ARPA hybrid CMOS-SEED multi-project fabrication run [6]. At the time this paper was written, only the electrical version of the chip was available for testing. The receivers and transmitter circuits used on the chip have previously been demonstrated [7]; the active area of the processor core (e.g. circuit area with optical I/Os but without the electrical padframe) is approximately 2mm^2 . A key element of our chip design is the integration of the optical I/O

padframe directly over active digital CMOS circuitry that has been demonstrated earlier [8]. Without this layout feature, the area of the processor core would be at least twice as large.

With our present design, a 1cm^2 hybrid CMOS-SEED chip can easily integrate thirty two (32) 64-bit processors that perform 3,200 64-bit MIPS when operating with a 100MHz clock. To achieve the same performance with a bit-serial approach would require 2,048 bit-serial processors (64×32), also operating at 100MHz. Both chip designs contain 4,096 optical receiver circuits and 2,048 optical transmitter circuits. However, the bit-parallel approach is more efficient for computations that involve 64-bit arithmetic operations and do not have enough parallelism to occupy all 2,048 bit-serial processors. For example, consider the problem of adding two vectors, each vector containing 32 64-bit numbers. This operation takes up one clock cycle using the chip with 64-bit processors. On the other hand, 64 clock cycles are required for the same computation using the chip with bit-serial processors. In this case, only 32 processors out of 2,048 are utilized in the calculation. While there are specific applications that can benefit from either the bit-serial or the bit-parallel architectures, there are additional considerations in favor of the bit-parallel scheme, including:

- 1) Better software compatibility with current commercial microprocessor architectures that use 32-bit or 64-bit word sizes.
- 2) Multiple-bit operations can be implemented with minimum latency. For example, a 64-bit addition operation, can be calculated in one (1) clock cycle using a fast carry-look-ahead adder circuit [9]. In contrast, a bit-serial adder requires sixty four (64) clock cycles to perform the same computation.
- 3) With fewer processors, scheduling and distribution of the work load among the processors becomes a simpler task.

Since our design takes advantage of existing electronic circuits, it is highly scaleable. With 0.5-micron HP14TB CMOS technology [10], the area of the 64-bit ALU can be reduced by a factor of 3. This savings in chip area can be used to implement new processor instructions, add additional registers, expand the processor bit-parallelism, or increase the number of processors on the chip. It should be noted that the number of on-chip optical I/O channels is dependent on the power consumption of receiver/transmitter circuits. With current hybrid CMOS-SEED technology, 200-2000 optical I/O channels can be achieved with power consumption of 3-5 mw per channel operating at 50-100 megabits per second (Mbps)/channel. One way to reduce the number of optical I/O channels is to operate the optical links at higher speed than the silicon circuitry. In this approach, multiple bits are multiplexed and transmitted over the same optical link, thereby reducing the on-chip power consumption associated with optical I/Os.

The development of a high-speed and high-capacity memory subsystem for our parallel processor design is an important issue. For example, the 1cm^2 chip design with fifty 64-bit processors requires a multi-port memory system capable of reading 128 words and writing 64 words on every clock cycle, with each word having 64-bits. The methodology for designing smart pixel integrated circuits to implement such a memory subsystem is described in [11]. For example, figure 2 shows a 16 kilobit photonic page buffer IC with random page access capability that was designed, fabricated and electrically tested at 100MHz [12]. This 21mm^2 IC was fabricated in 0.8 micron HP26G CMOS technology and integrates approximately 200,000 transistors. With future 0.18 micron CMOS technology [13], the memory capacity can be increased to 256 megabits with a total throughput of 10 to 100 Gbps and 10ns access time.

With the above approach, a complete hybrid CMOS-SEED parallel processor can be built using just two chips that are interconnected using FSOI. This design integrates thirty two 64-bit processors with a high-speed memory subsystem and achieves 3,200 64-bit MIPS when operating with a 100MHz clock. Circuit optimization techniques, such as ALU pipelining and memory interleaving, can increase the clock speed by a factor of two to four. Further performance and/or functionality gains can be achieved using a more advanced CMOS process. Using additional processor and memory chips, we can develop systems with even higher performance, albeit at greater cost and increased complexity.

The remainder of this paper focuses on the design, layout and electrical testing of the 64-bit microprocessor core that we have developed. Section 2 describes the processor architecture. In section 3, the layout of the processor chip is examined. The results of electrical testing are detailed in section 4. Finally, section 5 wraps up with some conclusions.

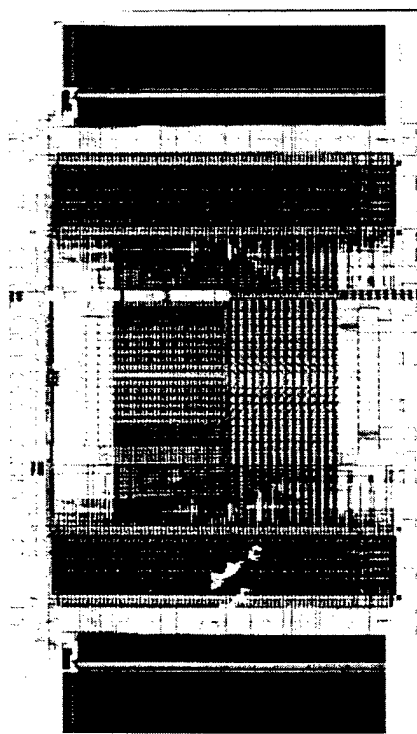

Figure 2. Layout of a 32 page, 504 bits/page photonic page buffer IC. This type of IC could be used as the memory subsystem for our 64-bit processor design.

1.6. Chip Architecture

A VLSI microprocessor is specified by its architecture and instruction set. The architecture of our 64-bit microprocessor core is shown in figure 3. Due to chip area constraints, we have chosen to implement a small subset (or core) of functionality used in modern VLSI microprocessors. This includes a 64-bit arithmetic-logic unit (ALU) which implements sixteen (16) boolean and thirty two (32) fixed-point arithmetic operations, a 64-bit electrically scanable register (ESR) which provides electrical test and on-chip data storage capability, and several 64-bit multiplexer arrays which control the dataflow throughout the chip.

The ALU circuit has two 64-bit data inputs and a single 64-bit data output (see figure 4). Table 1 shows the boolean and arithmetic operations that can be performed by the ALU. Arithmetic functions propagate the carry bit from the least significant bit (LSB) to the most significant bit (MSB) while logic functions operate on all 64-bits in parallel. To ensure high-speed operation for arithmetic functions, the ALU circuit employs dedicated parallel carry look-ahead generation circuitry. Control signals for the ALU are input from electrical pads. The ALU carry and overflow signals are output electrically. The two 64-bit ALU inputs are generated from 128 optical pads. The 64-bit ALU output is fed into a 64-bit ESR circuit.

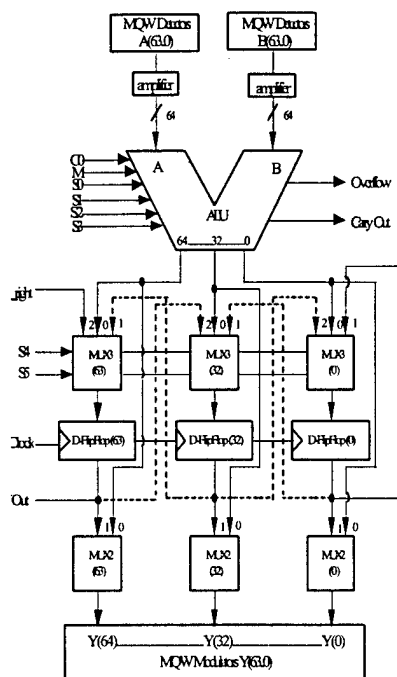

Figure 3. Architecture of the 64-bit microprocessor core design.

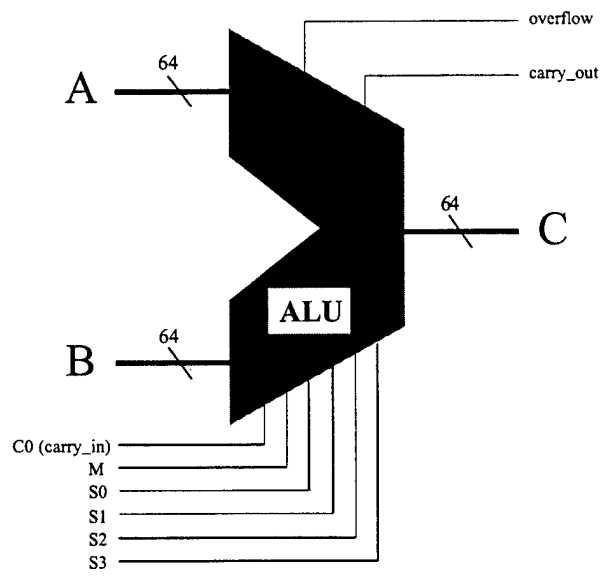

Figure 4. Block diagram of the 64-bit ALU circuit.

Table 1. 64-bit ALU truth table. The “+” and “-“ signs denote 64-bit addition and subtraction, respectively. The A and B represent the two 64-bit operands.

S3	S2	S1	S0	M	c0	ALU OUTPUT
0	0	0	0	0	X	not(A)
0	0	0	1	0	X	not(A and B)
0	0	1	0	0	X	not(A) or B
0	0	1	1	0	X	1
0	1	0	0	0	X	not(A or B)
0	1	0	1	0	X	not(B)
0	1	1	0	0	X	not (A xor B)
0	1	1	1	0	X	A or not(B)
1	0	0	0	0	X	not(A) and B
1	0	0	1	0	X	A xor B
1	0	1	0	0	X	B
1	0	1	1	0	X	A or B
1	1	0	0	0	X	0
1	1	0	1	0	X	A and not(B)
1	1	1	0	0	X	A and B
1	1	1	1	0	X	A
0	0	0	0	1	0	A - 1
0	0	0	1	1	0	(A and B) - 1
0	0	1	0	1	0	(A and not(B)) - 1
0	0	1	1	1	0	-1 (2's complement)
0	1	0	0	1	0	A + (A or not(B))
0	1	0	1	1	0	(A and B) + (A or B)
0	1	1	0	1	0	A - B - 1
0	1	1	1	1	0	A + not(B)
1	0	0	0	1	0	A + (A or B)
1	0	0	1	1	0	A + B
1	0	1	0	1	0	(A and not(B))+(A or B)
1	0	1	1	1	0	A or B
1	1	0	0	1	0	A + A
1	1	0	1	1	0	(A and B) + A
1	1	1	0	1	0	(A and not(B)) + A
1	1	1	1	1	0	A
0	0	0	0	1	1	A
0	0	0	1	1	1	A and B
0	0	1	0	1	1	A and not(B)
0	0	1	1	1	1	0
0	1	0	0	1	1	A + (A or not(B)) + 1
0	1	0	1	1	1	(A and B)+(A or not(B))+1
0	1	1	0	1	1	A - B
0	1	1	1	1	1	(A or not(B)) + 1
1	0	0	0	1	1	A + (A or B) + 1
1	0	0	1	1	1	A + B + 1
1	0	1	0	1	1	(A or not(B))+(A or B)+1
1	0	1	1	1	1	(A or B) + 1
1	1	0	0	1	1	A + A + 1
1	1	0	1	1	1	(A and B) + A + 1
1	1	1	0	1	1	(A and not(B)) + A + 1
1	1	1	1	1	1	A + 1

The ESR circuit is composed of a 64 element array of edge-triggered flip-flops and a 64 element array of three-to-one (3-to-1) multiplexers. These circuits are connected to implement a 64-bit bi-directional shift register with serial electrical read/write access from both the MSB and the LSB sides of the register. The major purpose of the ESR circuit is to simplify electrical and optical testing of the chip, although it can also be used to implement bit-shift and bit-rotate instructions during normal processor operation. Specifically, each of the 64 optical transmitters and 128 optical receivers are individually accessible from an electrical I/O pad using the ESR circuit (this access is provided by appropriately shifting the data through the ESR and configuring the ALU to operate in the pass-through mode). The output of the ESR circuit drives a 64 element array of two-to-one (2-to-1) multiplexers. This multiplexer array, in turn, drives the 64 element array of optical MQW modulators. The purpose of the 2-to-1 multiplexer array is to permit bypassing of the ESR circuit, allowing the ALU outputs to directly drive the optical modulator array.

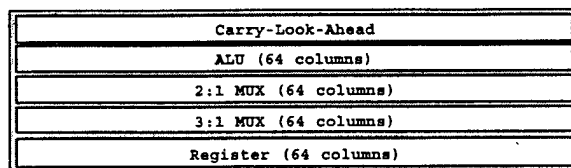

Figure 5. Optimal floorplan for the 64-bit processor using the datapath layout style.

1.7. Chip Layout

Currently, the most popular smart pixel chip layout scheme is to design a self-contained "smart pixel" circuit with electronic processing circuitry, optical transmitter/receiver circuitry, and optical I/O devices. This circuit is then replicated in a two-dimensional "smart pixel" array structure. While this approach is highly effective for simple bit-serial processors, it is difficult to use it for the layout of a 64-bit microprocessor core. In our 64-bit processor design, most of the chip area is taken up by the 64-bit ALU and the 64-bit ESR circuits. Typically, these VLSI circuits use a datapath layout style that creates a highly regular row and column structure as shown in figure 5. The datapath layout style is preferred for multiple-bit processing circuits because it achieves the most uniform timing for all bits in a word and because it minimizes routing congestion for these types of circuits. However, partitioning a datapath circuit to fit the conventional "smart pixel" layout would quickly become an impossible task. The challenge lies in dividing the datapath circuit into many small sub-circuits that are replicated in a two-dimensional array while still retaining efficient routing and uniform timing characteristics.

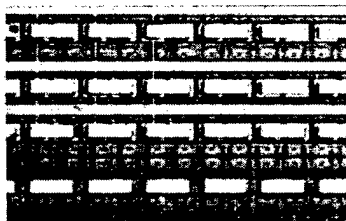

Figure 6. Microphotograph showing portion of a CMOS-SEED chip with optical devices integrated directly on top of active CMOS circuits. See reference 8 for details.

Our method for layout of the 64-bit processor smart pixel IC is to integrate the optical devices (e.g. photodetectors and modulators) directly over active silicon VLSI circuits. This layout methodology was recently proposed and experimentally demonstrated for CMOS-SEED circuits [8]. Figure 6 shows a microphotograph from reference 8 where GaAs quantum well diodes are integrated directly on top of a two kilobit CMOS FIFO memory circuit. This layout approach enables us to efficiently combine a VLSI datapath layout with a 2-D array of optical devices. In our case, the 64-bit datapath was further divided into two 32-bit portions to achieve a 1.5mm x 1.5mm floorplan as shown in figure 7. This modification was necessary in order to fit the 64-bit processor design within the allocated 2mm x 2mm chip area. The 128 transimpedance amplifiers, that convert photodetector current into digital format, are arranged in two rows of 64 columns. The 64 optical modulators are driven directly from the outputs of the 64-bit 2-to-1 multiplexer array. Figure 8 shows the complete layout of the 64-bit processor chip together with the third-level metal routing used for the optical I/O padframe. The next paragraph describes the optical and electrical I/O pad frames used in our chip design.

The optical I/O “pad frame” is arranged as a 20 by 10 array providing a total of 200 quantum well diodes that operate as MQW modulators or PIN photodetectors, depending on applied bias voltage. The electrical I/O and power pads are positioned at the periphery of the chip. Figure 8 shows the position of electrical and optical pads on the 64-bit processor chip. In this figure, a vertical separator line divides sub-array of photodetectors on the left side from the smaller sub-array of modulators on the right side. The labeling scheme for optical I/O pads numbers rows from top to bottom, while columns are lettered from left to right. Since the 64-bit processor design uses 192 optical I/O, there are eight (8) unused optical I/O pads.

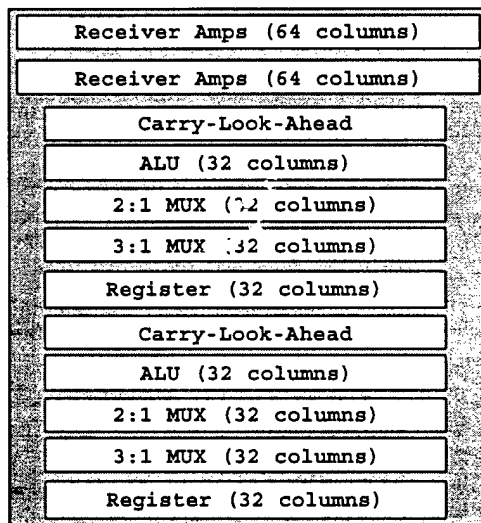

Figure 7. Floorplan used in the 64-bit processor chip.

1.8. Chip Testing

At the time this paper was written, only the electrical version of the chip was fabricated and therefore available for testing. This section describes functional testing that was undertaken

to verify correct electrical functionality of the chip and the test fixture that was used to perform the testing.

Functional testing was performed using a compact, self-contained test fixture that uses an FPGA chip to supply and monitor high-speed electrical signals from the 64-bit processor chip. The test program resides in an EPROM chip and the system clock is derived from a 100MHZ (or slower) clock generator chip. Physically, the test fixture resides in a 6"x9" 4-layer high-performance printed circuit board (PCB). Typical operation of the test fixture requires several steps. First, the test program is written on a Sun workstation using the VHSIC hardware description language (VHDL) [2]. It is simulated against a software model of the 64-bit processor chip to verify correct functionality. Next, the test program is synthesized to an FPGA using a synthesis CAD tool and an EPROM bit-file is generated. An EPROM programmer is then used to write the bit-file into an EPROM chip. The EPROM chip is inserted into the ZIF socket on the PC board. Finally, when the PC board is powered on, the test program is loaded into the FPGA chip and automatically executed supplying test vectors to the 64-bit processor chip.

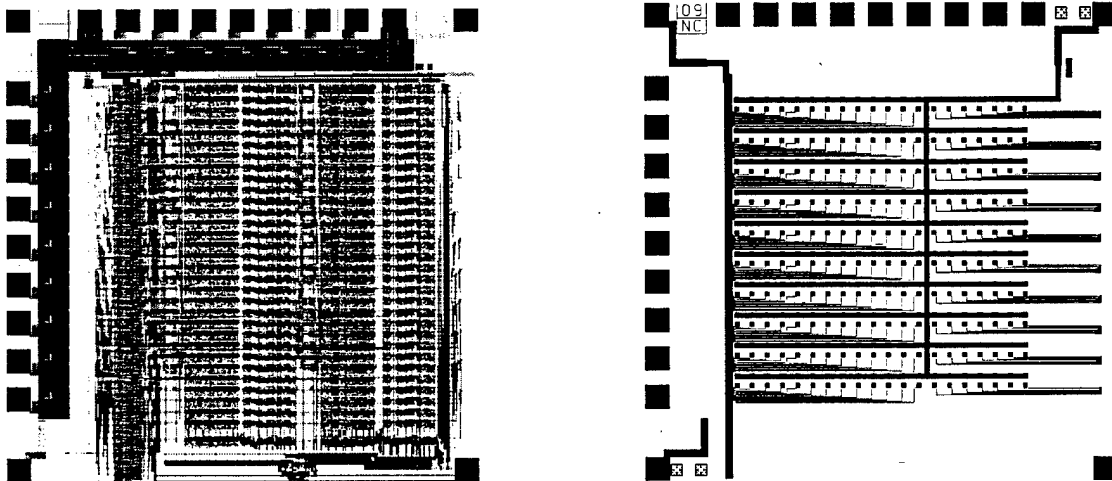

Figure 8. This figure shows the layout of the 64-bit processor chip (top) and the optical I/O padframe routed in third-level metal (bottom) directly above active silicon circuitry.

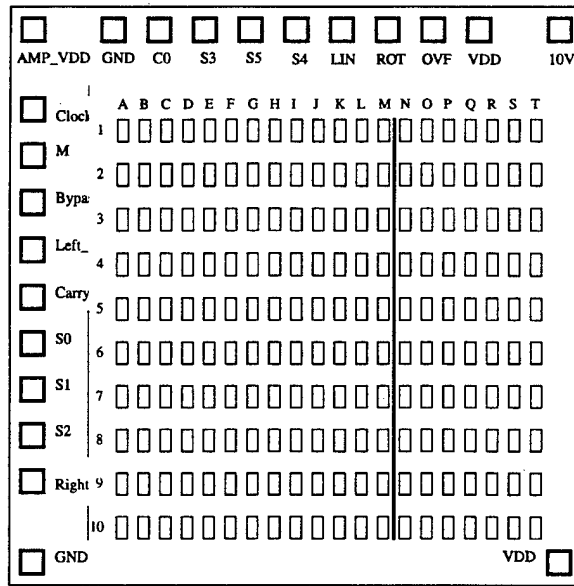

Figure 9. Floorplan for the 64-bit processor chip showing the electrical I/O pads located on the periphery of the chip and the 2-D optical I/O padframe (pads A1 through T10) located in the center of the chip.

The first test performed on the chip was an electrical continuity check between power and ground pins. The purpose of this test is to check for power rail shorts on the IC. This type of defect can have disastrous consequences and must be checked before applying power to the chip. Next, the power consumption of the chip was measured to verify that the 128 transimpedance amplifiers used to amplify photodetector current are properly biased. Since the digital portion of the chip uses CMOS logic circuitry, it has no static power consumption. On the other hand, the transimpedance amplifiers always draw DC current and thus have a non-zero static power consumption. For this test the chip current draw was measured with power pins connected and with all input signal pins tied to ground. The total current drawn from the supply was measured at 78mA corresponding to 0.39W power consumption. Thus each transimpedance amplifier is drawing $610\mu\text{A}$ of current ($78\text{mA} / 128$ amplifiers). This measurement is in excellent agreement with Spice simulation of the transimpedance amplifier that predicts a current draw of $650\mu\text{A}$.

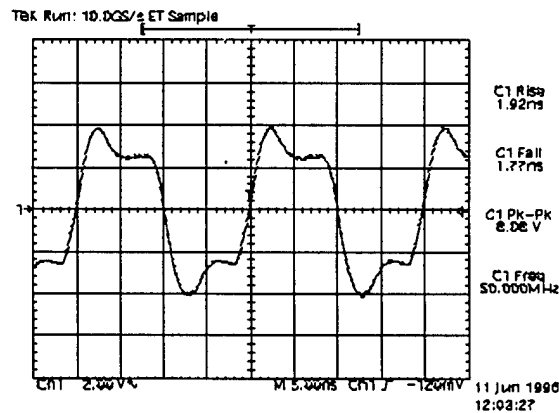

Figure 10. This figure shows the output of the ESR circuit test working at 20Mbit/sec.

The next step was to verify the correct functionality of the chip. Since the 128 optical inputs and 64 optical outputs were not directly accessible, testing must rely on the ESR circuit to shift out the data generated by the 64-bit ALU. To test the ESR circuit itself, a repeating pattern (1010...) was input to the shift-in port of the ESR and observed to emerge from the shift-out port of the ESR after 64 clock cycles. Figure 10 shows the measured chip output for the ESR shift-out signal. This test was performed at 100MHz with electrical signal rise and fall times below 2 nanoseconds. This indicates that the ESR circuit is capable of operating at 100MHz clock rates.

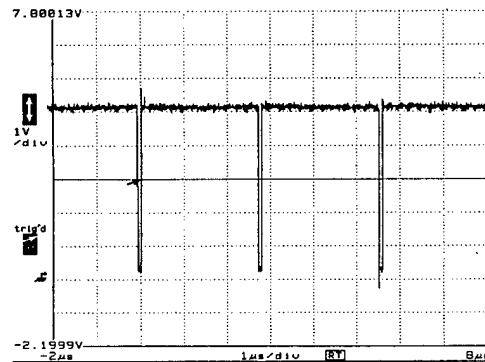

Figure 11. Measured results from testing the not(A) ALU function.

It is possible to test the 64-bit ALU even though its inputs are not directly accessible. The 128 ALU inputs are connected to the outputs of 128 transimpedance amplifiers. Without the optical devices on the chip, all the transimpedance amplifiers should produce a logic zero ('0') output. If all the inputs to the ALU are '0', the operation of many of its functions can still be verified. The first test that was performed was to check the not(A) and not(B) functions of the ALU. Inverting a '0' 64-bit input should produce a '1' 64-bit output. The ALU control signals were configured to perform the not(A) function. Next proper control signals were applied to load the 64-bit ALU output into the ESR. Next, the ESR circuit was clocked to shift the 64-bit result outside of the chip. While the 64-bit result was shifted out from the left side of the ESR, the right side of the ESR is configured to shift in zeros ('0'). The test was setup up to monitor the output of the ESR and to restart the test upon detecting a zero output. Figure 11 shows the measured ESR output for this test where the output of the ALU is '1' as expected and the '0' pulse indicates the end of a complete test cycle. Using a similar approach, a number of other ALU functions were electrically tested.

To test the high-speed operation of the ALU, a sequence of ALU operations was repeatedly applied to produce a periodic bit pattern (11010...) in the MSB position of the 64-bit ALU output. This 64-bit output was then loaded into the ESR, with the MSB position becoming immediately visible from an electrical output pin. The test was run with different clock speeds up to the maximum 100MHz speed supported by our test fixture. Figure 12 shows the measured and fully functional result for 100MHz operation.

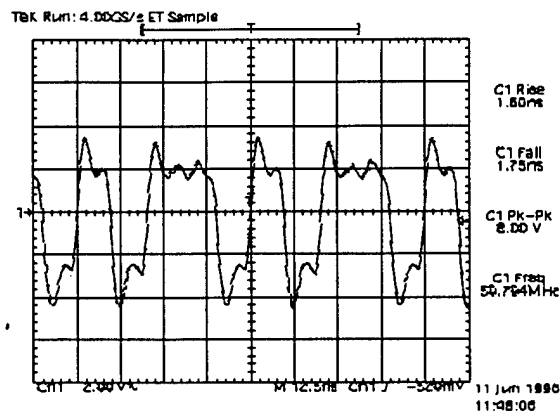

Figure 12. High-speed testing of 64-bit processor chip. The measurement on the left side shows correct operation at 50MHz (e.g. 11010... output).

1.9. References

- [1] J.W. Goodman, F.J. Leonberger, S.Y. Kung, and R.A. Athale, "Optical interconnections for VLSI systems," *Proceedings IEEE*, **72**, pp. 850, 1984.
- [2] *Proceedings for 2nd International Conference on Massively Parallel Processing Using Optical Interconnects*, Ed: Eugene Schenfeld, IEEE Press, San Antonio, TX (Oct. 1995).
- [3] F. E. Kiamilev, S. C. Esener, R. Paturi, Y. Fainman, P. Mercier, and S.H. Lee, "Programmable optoelectronic multiprocessors and their comparison with symbolic substitution for digital optical computing," *Optical Engineering*, Vol. 28, No. 4, pp. 396-409 (1989).
- [4] CMOS26 Design Reference Manual, *Hewlett-Packard ICBD Division*, 1992.
- [5] K. W. Goossen, J. A. Walker, L. A. D'Asaro, S. P. Hui, B. Tseng, R. Leibenguth, D. Kossives, D. D. Bacon, D. Dahringer, L. M. F. Chirovsky, A. L. Lentine, and D. A. B. Miller, "GaAs MQW modulators integrated with silicon CMOS," *IEEE Photonics Technology Letters*, **7** 4 (April 1995), pp. 360-362.
- [6] Hybrid CMOS-SEED Workshop, *George Mason Univ.*, Washington D.C. (July 1995).
- [7] A. V. Krishnamoorthy, A. L. Lentine, K. W. Goossen, J. A. Walker, T. K. Woodward, J. E. Ford, G. F. Aplin, L. A. D'Asaro, S. P. Hui, B. Tseng, R. Leibenguth, D. Kossives,

-
- D. Dahringer, L. M. F. Chirovsky, and D. A. B. Miller, "3-D integration of MQW modulators over active sub-micron CMOS circuits: 375Mb/s transimpedance receiver-transmitter circuit," *IEEE Photonics Technology Letters*, 7 11 (November 1995), pp. 1288-1290.
- [8] A.V. Krishnamoorthy, J.E. Ford, K.W. Goosen, J.A. Walker, A.L. Lentine, S.P. Hui, B. Tseng, L.M.F. Chirovsky, R. Leibenguth, D. Kossives, D. Dahringer, L.A. D'Asaro, F.E. Kiamilev, G.F. Aplin, R.G. Rozier and D.A.B. Miller, "Photonic Page Buffer Based on GaAs MQW Modulators Bonded Directly Over Active Silicon CMOS Circuits," Accepted for publication in *Applied Optics*, Special Issue on Optical Memory, August 1995.
- [9] A. Bellaouar and M. Elmasry, "Low-power digital VLSI design," Kluwer Academic Publishers, New York, NY, 1995.
- [10] CMOS14TB Design Reference Manual, *Hewlett-Packard ICBD Division*, 1995.
- [11] F. E. Kiamilev, R.G. Rozier, A.V. Krishnamoorthy (submitted to these proceedings).
- [12] F.E. Kiamilev, R.G. Rozier, A.V. Krishnamoorthy, and J.L. Rieve, "Design of Large-Scale Photonic Page Buffer ICs," in Proc. IEEE/LEOS 1996 Summer Topical Meeting on Smart Pixels, (Keystone, CO).
- [13] "1994 SIA Roadmap," Semiconductor Industry Association, San Jose, CA, 1994.