



UNCLASSIFIED

NAWCWD TM8330

**ENGINEERING INVESTIGATION OF FAILURES OF CABLE USED
TO TOW THE TDU-32A BANNER TARGET FROM T2C AIRCRAFT**

by Brent Meeker
6 DEC 2000



NAVAL AIR WARFARE CENTER, WEAPONS DIVISION
CODE 531100E

APPROVED FOR PUBLIC RELEASE;
DISTRIBUTION IS UNLIMITED

20010511 005

REPORT DOCUMENTATION PAGE

Form Approved
OMB No. 0704-0188

Public reporting burden for this collection of information is estimated to average 1 hour per response, including the time for reviewing instructions, searching existing data sources, gathering and maintaining the data needed, and completing and reviewing the collection of information. Send comments regarding this burden estimate or any other aspect of this collection of information, including suggestions for reducing this burden, to Washington Headquarters Services, Directorate for Information Operations and Reports, 1215 Jefferson Davis Highway, Suite 1204, Arlington, VA 22202-4302, and to the Office of Management and Budget, Paperwork Reduction Project (0704-0188), Washington, DC 20503.

1. AGENCY USE ONLY <i>(Leave blank)</i>		2. REPORT DATE 6 Dec 2000	3. REPORT TYPE AND DATES COVERED 2000	
4. TITLE AND SUBTITLE ENGINEERING INVESTIGATION OF FAILURES OF CABLE USED TO TOW THE TDU-32A BANNER TARGET FROM T2C AIRCRAFT (U)			5. FUNDING NUMBERS	
6. AUTHOR(S) Brent Meeker				
7. PERFORMING ORGANIZATION NAME(S) AND ADDRESS(ES) NAWCWD, Point Mugu Threat/Target Systems Department (Code 531100E)			8. PERFORMING ORGANIZATION REPORT NUMBER NAWCWD TM 8330	
9. SPONSORING/MONITORING AGENCY NAME(S) AND ADDRESS(ES)			10. SPONSORING/MONITORING AGENCY REPORT NUMBER	
11. SUPPLEMENTARY NOTES				
12A. DISTRIBUTION/AVAILABILITY STATEMENT Approved for public release; distribution is unlimited.			12B. DISTRIBUTION CODE	
13. ABSTRACT <i>(Maximum 200 words)</i> <p>(U) Twice in May of 2000, cables used to tow TDU-32A target banners broke while being towed by T2C aircraft of VT-9 flying out of Meridian MS. There had been two similar incidents in the preceding 20 months. In each case the cable broke about thirteen feet aft of the tow point on the aircraft and the banner portion of the cable was not recovered. The breaks occurred or were first noticed following turns. This pattern of cable breakage caused an engineering investigation to be initiated. Because the break point was just aft of the T2C exhaust, it was suspected that the cable had entered the exhaust during a turn or had contacted the aircraft in the vicinity of the exhaust and that this had caused or contributed to the breakage. The immediate response of the Commanding Officer was to restrict the aircraft to bank angles of less than 30deg when towing banners.</p> <p>(U) The purpose of this engineering investigation was to determine the cause of the cable breakage and to recommend action that would obviate further occurrences. The position of the break along the cable indicated that the failure was related to either heating by the exhaust or by abrasion or stress concentration in the cable due to contact with the aircraft in the vicinity of the exhaust. Cable of substandard mechanical properties might also contribute.</p>				
14. SUBJECT TERMS			15. NUMBER OF PAGES 93	
			16. PRICE CODE	
17. SECURITY CLASSIFICATION OF REPORT Unclassified	18. SECURITY CLASSIFICATION OF THIS PAGE Unclassified	19. SECURITY CLASSIFICATION OF ABSTRACT Unclassified	20. LIMITATION OF ABSTRACT Unlimited	

NSN 7540-01-280-5500

Standard Form 298 (Rev. 2-89)
Prescribed by ANSI Std. Z39-18
298-102



UNCLASSIFIED

NAWCWD TM8330

**ENGINEERING INVESTIGATION OF FAILURES OF CABLE USED
TO TOW THE TDU-32A BANNER TARGET FROM T2C AIRCRAFT**

by Brent Meeker

6 DEC 2000



**NAVAL AIR WARFARE CENTER, WEAPONS DIVISION
CODE 531100E**

**APPROVED FOR PUBLIC RELEASE;
DISTRIBUTION IS UNLIMITED**

**ENGINEERING INVESTIGATION OF FAILURES OF CABLE USED
TO TOW THE TDU-32A BANNER TARGET FROM T2C AIRCRAFT**

by Brent Meeker
6 DEC 2000

APPROVED BY *Berry Brown* DATE *1/8/01*
BERRY BROWN, NAWCWD CODE 531000E

REVIEWED BY *H. Carinio* DATE *1/8/01*
HARRY CARINIO, NAWCWD CODE 531100E

PREPARED BY *D. Brent Meeker* DATE *1/2/01*
BRENT MEEKER, NAWCWD CODE 531100E

TABLE OF CONTENTS

SUMMARY	2
ACKNOWLEDGEMENTS	3
INTRODUCTION	4
INSPECTION	7
LABORATORY TESTS	10
FLIGHT CONFIGURATION	12
ANALYSIS	14
DISCUSSION	23
CORRECTIVE ACTIONS	24
CONCLUSION	25
REFERENCES	26

APPENDICES

- A. TOW BANNER STEEL LEADER CABLE FAILURE ANALYSIS
- B. STEADY-STATE TOW CABLE CONFIGURATION
- C. TOW CABLE / JET INTERFERENCE CBAS SIMULATION ANALYSIS
- D. CALCULATION OF T2C EXHAUST RELATIVE TO TOWPOINT DURING LEVEL TURNS

ENGINEERING INVESTIGATION OF FAILURES OF CABLE USED TO TOW THE TDU-32A BANNER TARGET FROM T2C AIRCRAFT

SUMMARY

This investigation was conducted at the direction of PMA-208D1. After four instances of cable failure while towing the TDU-32A target banner behind T2C aircraft, and engineering investigation was initiated. Because of the engine exhaust configuration and tow attachment point on the T2C aircraft, a sharp turn can bring the tow cable into the vicinity of the engine exhaust. This investigation found that the exhaust heating reduces the cable strength sufficiently to cause it to fail during turns at 150KEAS. Analysis of the tow cable configuration in flight found that position of the cable relative to the exhaust is sensitive to aircraft angle of bank (AoB), turn radius and abruptness of the turn initiation. It is recommended that the T2C aircraft be limited to 30⁰ AoB for sharply initiated turns or, for turns that are entered gradually over several seconds that the AoB be limited to 45⁰.

ACKNOWLEDGEMENTS

Valuable information and photographs were provided by Maj. Douglas Drew and Jerry Fox at NAS Meridian MS. Laboratory testing and metallurgical expertise was provided by Daniel Polly of the Naval Civil Engineering Laboratory, Port Hueneme, CA. Dynamic computer modelling was provided by Don Ferguson and Dick Kroeger, U. S. Army, Huntsville, AL.

INTRODUCTION

Background

Twice in May of 2000, cables used to tow TDU-32A target banners broke while being towed by T2C aircraft of VT-9 flying out of Meridian MS. There had been two similar incidents in the preceding 20 months. In each case the cable broke about thirteen feet aft of the tow point on the aircraft and the banner portion of the cable was not recovered. The breaks occurred or were first noticed following turns. This pattern of cable breakage caused an engineering investigation to be initiated. Because the break point was just aft of the T2C exhaust, it was suspected that the cable had entered the exhaust during a turn or had contacted the aircraft in the vicinity of the exhaust and that this had caused or contributed to the breakage. The immediate response of the Commanding Officer was to restrict the aircraft to bank angles of less than 30deg when towing banners.

Purpose

The purpose of this engineering investigation was to determine the cause of the cable breakage and to recommend action that would obviate further occurrences. The position of the break along the cable indicated that the failure was related to either heating by the exhaust or by abrasion or stress concentration in the cable due to contact with the aircraft in the vicinity of the exhaust. Cable of substandard mechanical properties might also contribute. The investigation was conducted in accordance with reference [1].

Description

The cable is described in reference [2] as P/N 51-4716-0113 1 1/64" OD Armored towline. It weighs 0.0757lb/ft. Its nominal breaking strength is 4,000lb. The cable is bought to the specifications of . The cable consists of a bundle of nineteen wires, laid in a left handed twist with a pitch of about one inch. Two wire diameters, 0.030" and 0.020", are used; 13 large and 6 small. Nominal wire bundle diameter is 0.130" There is an outer armor wrap of flat steel ribbon which is to protect the cable from abrasion when it is towed off the runway. The outer wrap does not contribute to the cable strength.

The TDU-32A banner is described in reference [3] from which figure 1 has been excerpted. It is a panel of nylon fabric 40ft long and 7.5ft wide. At its forward end is a tow bar and bridle assembly. The bridle assembly consists of four, one inch wide nylon straps. The bridle adds another 60ft to the overall length. The total weight is 87lb. The banner can be towed at speeds up to 250KIAS.

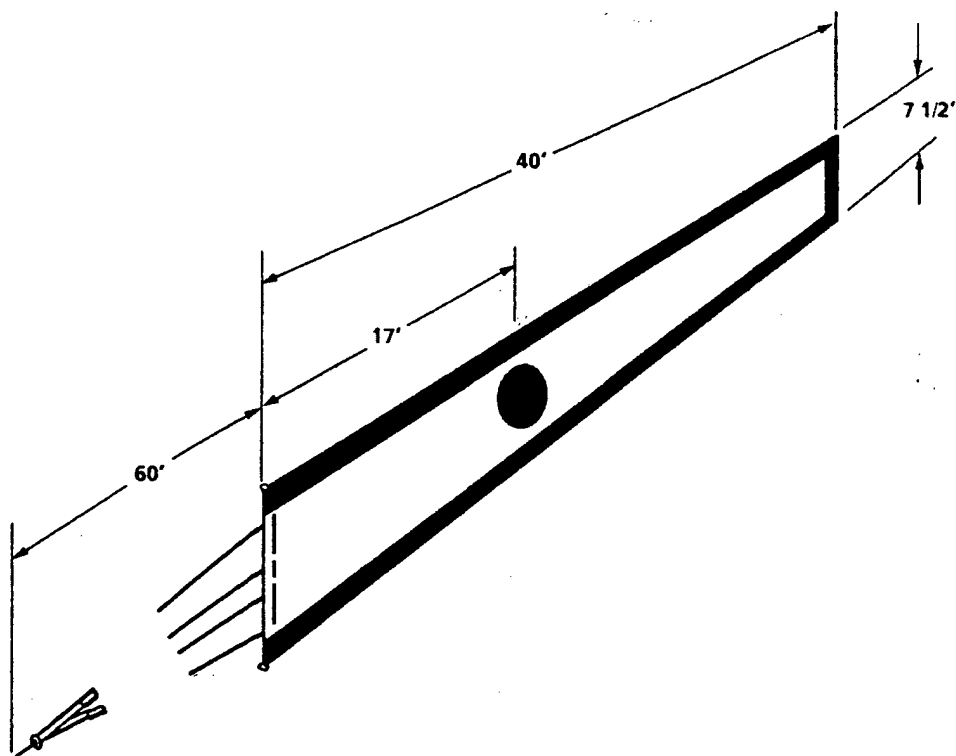

Figure 1. The TDU-32A banner.

The TDU-32A banner is towed on 800ft of cable. VT-9 uses the North American T2C aircraft. It is the only squadron that uses this aircraft type for banner towing. The attachment point for the tow cable is on the centerline of the aircraft 13.6ft forward of the exhaust plane as shown in figure 2.



Figure 2. T2C towing a TDU-32A banner in straight and level flight at 15Kft, 200KIAS.

The cable and banner are attached to the aircraft and laid out behind it on the runway. When they are towed off the armor wrap on the cable serves to protect it from abrasion. In a typical presentation the banner is towed in a racetrack pattern at 150KIAS. After the presentation, the cable is released as the aircraft passes over the runway. The cable and banner are recovered for reuse.

INSPECTION

Pieces of the two cables which broke in May and that returned with the aircraft were inspected. The broken pieces along with an unused piece of cable are shown in figure 3.

The first one was broken approximately 13' 10" aft of the thimble loop.

The cable was darkened, both armor and wires, for a little over two feet upstream of the break. The wires seen in the armor gaps, over the darkened section, look slightly rusty; further up they're shiny.

For approximately three feet upstream of the break, the gaps in the armor are relatively clean, so the wires can be clearly seen. Further up the cable, the gaps are filled with a dark substance which appears to be a mixture of dirt, grass, and grease. It's absence over the downstream three feet may be due to exhaust impingement.

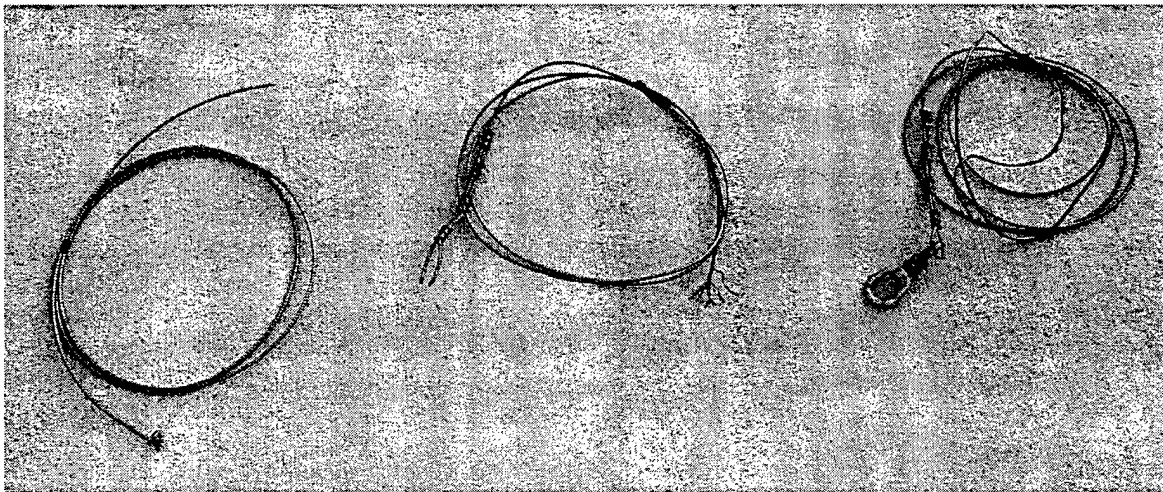

Figure 3. Sample cable pieces: an unused piece and two pieces which remained with the aircraft after in-flight failure.

The wires all broke at practically the same place. Except for one, the wires were still tightly wrapped – right up to the break. There is only 0.1" difference in the breakpoints from shortest to longest – and even some of this may be due to pulling out the inner wires as the outer ones broke. The individual wires show a slight reduction in diameter adjacent to their break; indicating failure in tension as shown in figure 4.

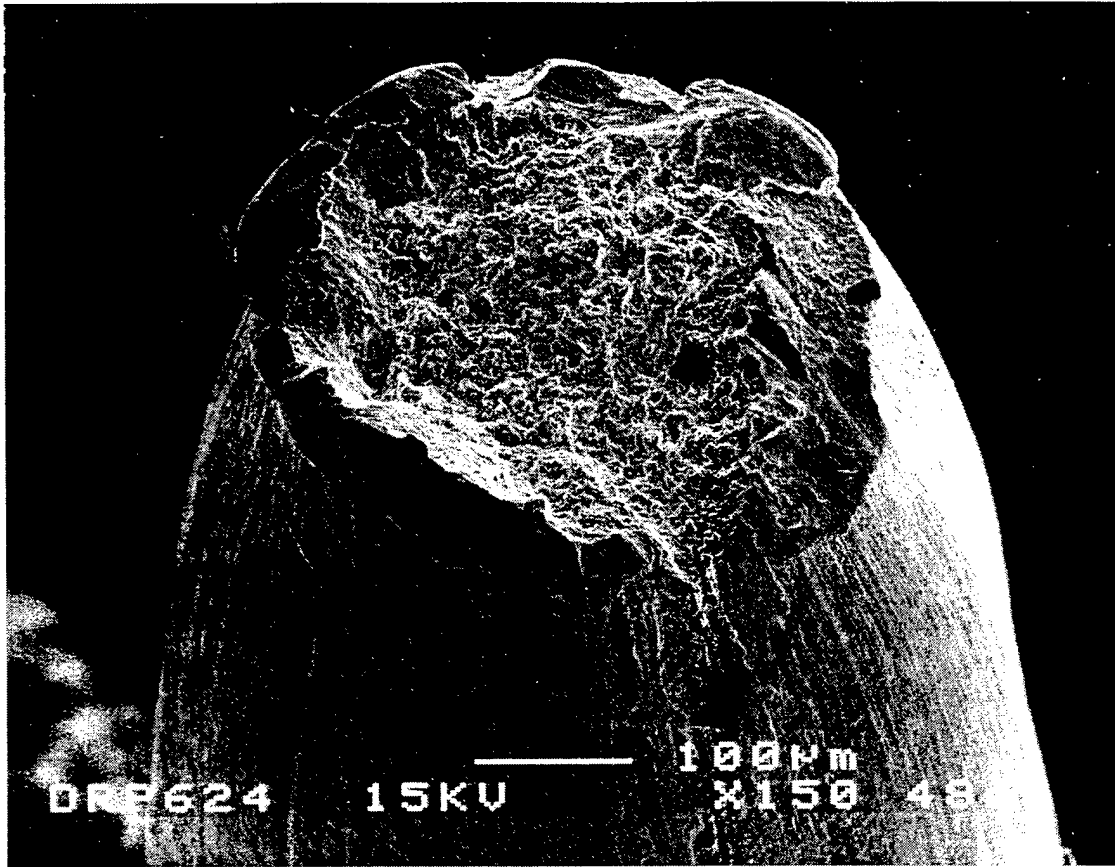

Figure 4. Photomicrograph of a broken wire from cable B.

The armor wrap broke at a point approximately 1.1" upstream of the cable break. This implies that the cable was not broken by external impact with a sharp edge; since in that case the armor would have been cut at the same point. About 0.9" of the armor wrap is unwrapped but still twisted. This probably happened after the cable broke as the load was transferred to the armor wrap until it parted.

The second broken cable (again only the aircraft end) came with the swivel. It was darkened over the last 15". The gaps between armor turns are relatively clean over the last 5'. This cable is more sharply bent over the last couple of feet; whereas the first cable was relatively straight. Overall length, not counting the swivel, is 15' 3".

The armor is more damaged than the armor of the first cable. There are a lot of impact marks on the armor over the last two feet. The armor is broken about 2" upstream of where the wires broke. There are two other breaks in the armor at 10" and 17" upstream. The greater length of this piece of cable may have caused it to flail against the aircraft more violently – hence the greater armor damage – or it may have been used on more operations.

The wires are unwound and spread apart over the last 1"; unlike the first cable which still had the wires tightly wound. Only twelve strands of the larger wires, 0.030" dia., are visible at the broken

end. They all broke within $\frac{1}{2}$ ". The seven smaller dia wires all broke closer to the aircraft by about 1.5", within the armor. As in the first cable, individual wires exhibit a slight reduction in diameter next to their breaks. None of the wires look rusty as did some in the first cable

LABORATORY TESTS

The two pieces of broken cable and a piece of unused cable were sent to the metallurgical laboratory at the NCEL (Naval Civil Engineering Laboratory), Port Hueneme. The laboratory test report is included as Appendix A. The cable was compared to the specification [2] and found to be in conformance.

The unused cable and on the two broken cables were tested for tensile strength. To determine whether the cable material had been weakened in the vicinity of the break, the cable ultimate strength was measured near the break and at the end away from the break.

Cable	Breaking Load (lb.)
A1 unused	4051
A2 unused	3935
B1 loop end	3954
B2 broken end	3360
C1 loop end	4017
C2 broken end	3113

Note that the strength was about 20% lower nearer the break. The reduction in strength at the broken ends, may be even greater as tests sections had to be approximately a foot from the fractures to allow thimbles and clips. In order to measure the strength closer to the break, individual wires were pull tested. The cable strength was then calculated as the sum over the wires. This yielded an estimate of 2873lb; still well above the expected load.

To estimate the effect of elevated temperature on the cable, a sample was tested using a constant strain-rate machine to increase the load to failure while the cable was heated to using a flame temperature of approximately 1700F. Figure 5 is a plot of load versus time as the strain was increased. The thermal time constant of the cable is around ten seconds, so the cable cross-section is near 1700F after the first twenty seconds. The cable begins to fail at a tensile load of approximately 500lb. The tensile load in flight is discussed below in the section on analysis. It is shown that the load can considerably exceed 500lb during a turn.

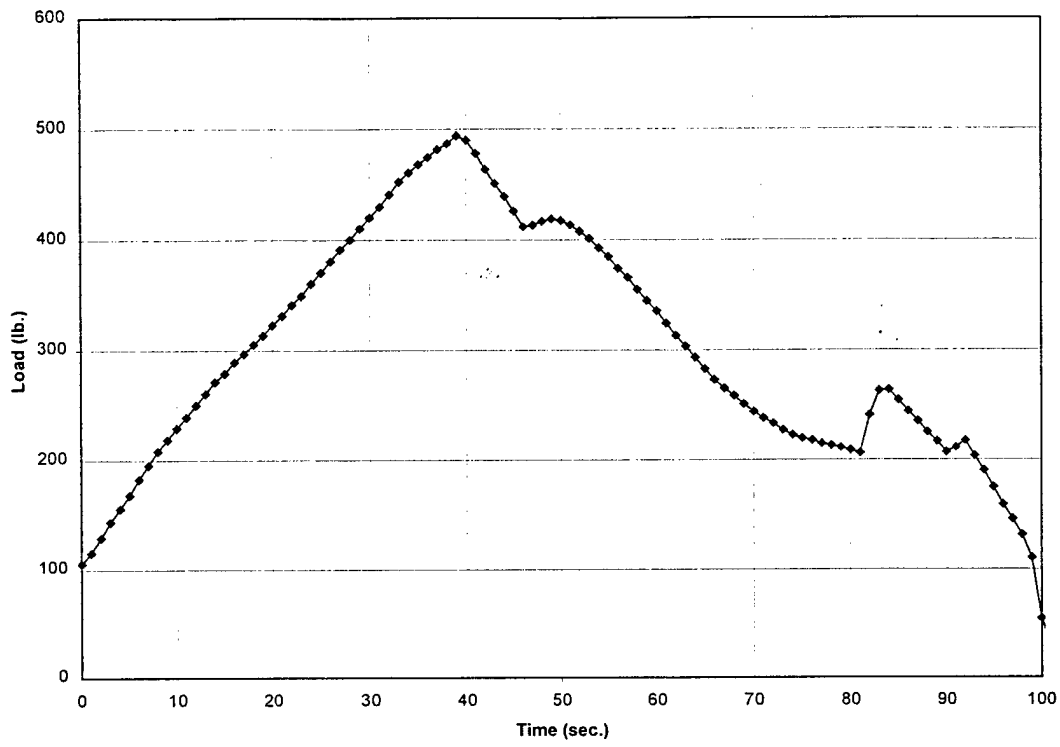

Figure 5. Load versus time for strain rate test at 1700F.

FLIGHT CONFIGURATION

In order to document the spatial relationship of the cable and aircraft in flight, Major Douglas Drew of VT-9 made several digital photos of a T2C towing the banner. These photos were needed to estimate the aircraft angle of attack relative to the cable angle. They were also very useful as a check on estimates of the cable and banner drag. Figure 6 shows the banner trailing approximately 106' below the aircraft at 200KIAS. Cable length is 800'. It can be seen that the

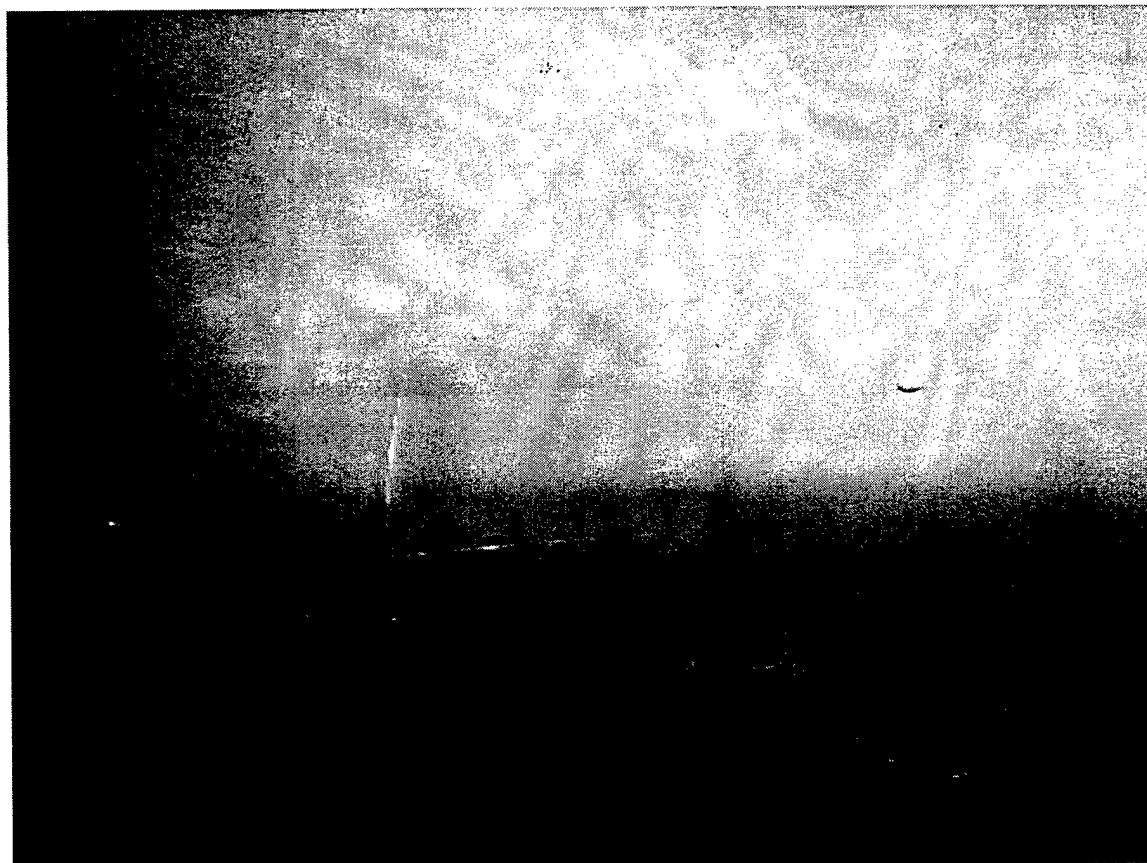

Figure 6. Straight and level tow at 3Kft, 200KIAS.

cable is almost perfectly straight. This confirms analytical estimates that the lift on the cable approximately equals its weight.

The configuration of the T2C exhaust is shown in figure 7. The exit nozzles are approximately 1.2ft in diameter. They are about 2.2ft apart, center-to-center. Also seen in this photo is a three cable leader proposed by Jerry Fox, SSSI Meridian site manager, as a possible solution to the cable breakage.

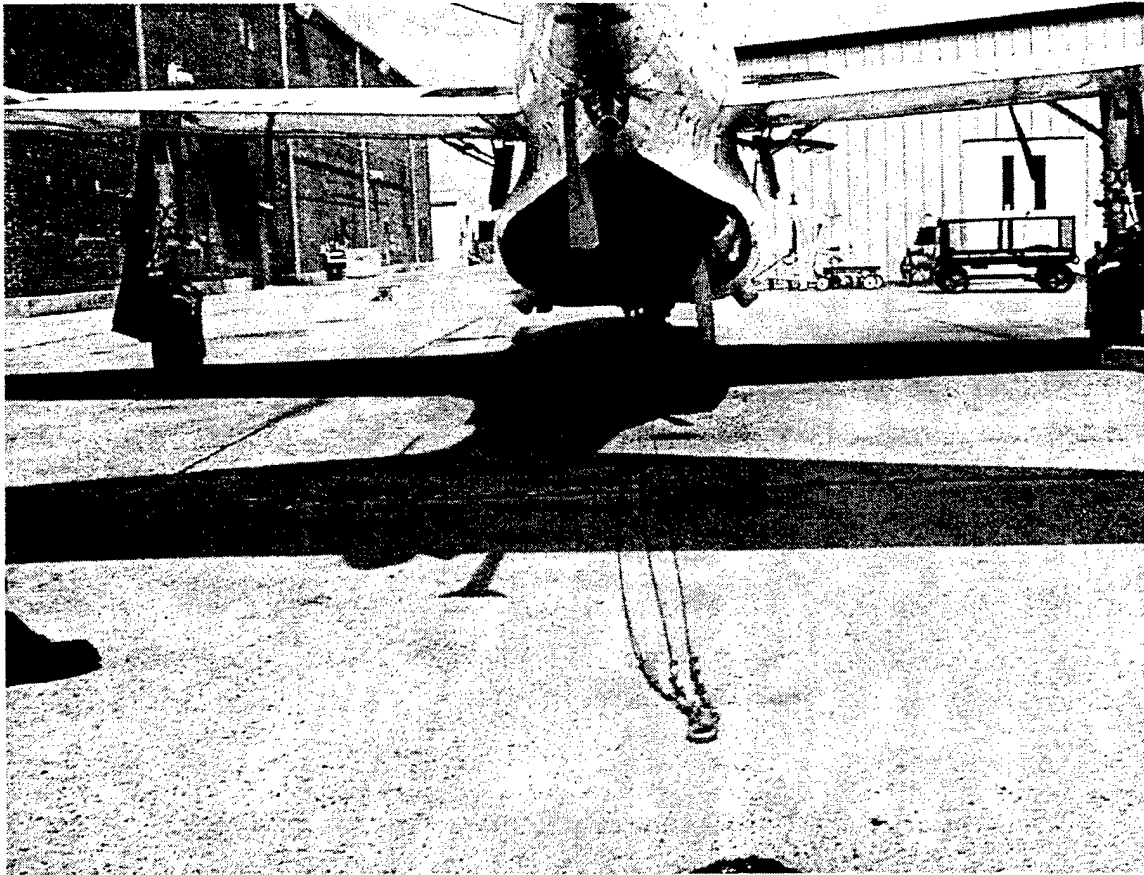

Figure 7. T2C engine exhaust and proposed three-cable leader.

ANALYSIS

Two different computer programs were used to determine whether there are conditions under which the tow cable would enter the aircraft engine exhaust stream and to estimate the tensile load in the cable. The first was a quasi-static analysis for straight and level or for a constant turn. The second, dynamically modeled the cable for a 180° level turn.

Quasi-Steady State Analysis

The simpler of these two determined only the steady-state, equilibrium shape of the cable for straight and level flight or for a level turn at a constant rate. As shown in Appendix B the assumption of steady-state reduces the problem of determining the cables towed shape to the integration of a set of ordinary differential equations. The greatest uncertainty in application of these equations is the drag of the banner. This was estimated by matching the droop tabulated in the NATOPS as shown in figure 8. No realistic combination of banner and cable aerodynamic parameters could be found to match all three NATOPS data points, but a banner drag area of 4.0ft^2 matched at 150KIAS and was close at the other two speeds.

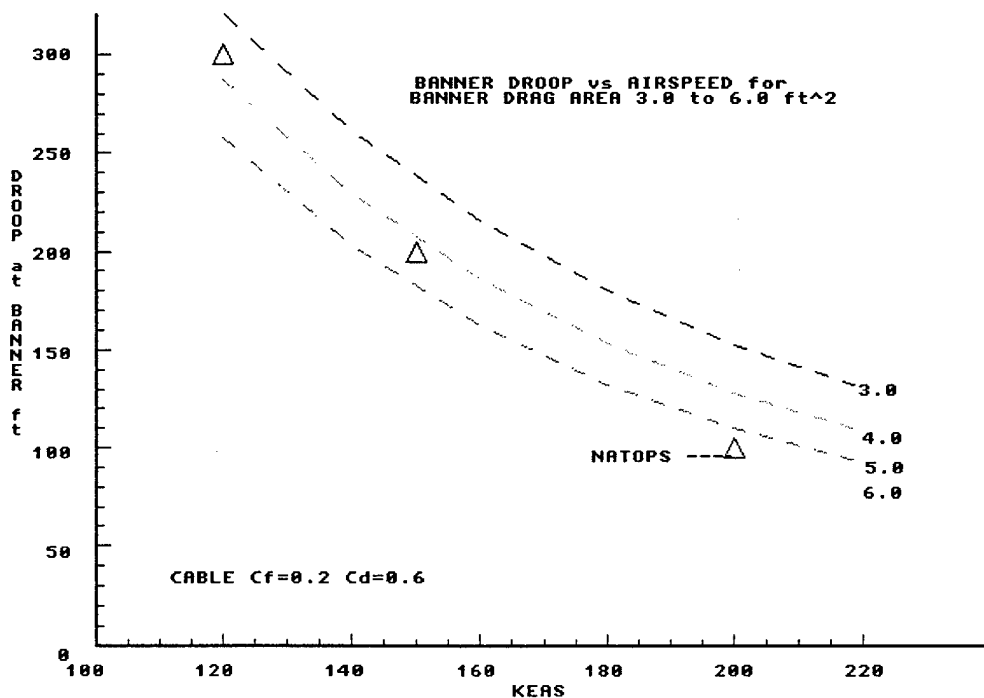

Figure 8. Comparison of droop predicted by steady-state analysis and tabulated NATOPS values.

Using this program, the position of the cables intersection with the exhaust plane of the aircraft was found for bank angles of 30° and 60° at airspeeds of 120KEAS, 150KEAS, and 200KEAS. This intersection was determined relative to the forward end of the cable, i.e. the tow point on the aircraft. In order to determine the proximity of the cable to the exhaust, it was necessary to take

into account the angle-of-attack of the aircraft. For straight and level flight this is illustrated in figure 9. At the lower speeds the angle-of-attack is greater and so the cable droops further, but also the exhausts are lower relative to the tow point. In a turn, the angle-of-attack must increase further to achieve the lateral acceleration and so the exhaust moves outward relative to the tow point. At the same time the tow cables intersection with the exhaust plane moves inward toward the center of the circle because the lagging banner causes the cable to cut across the circle as a secant.

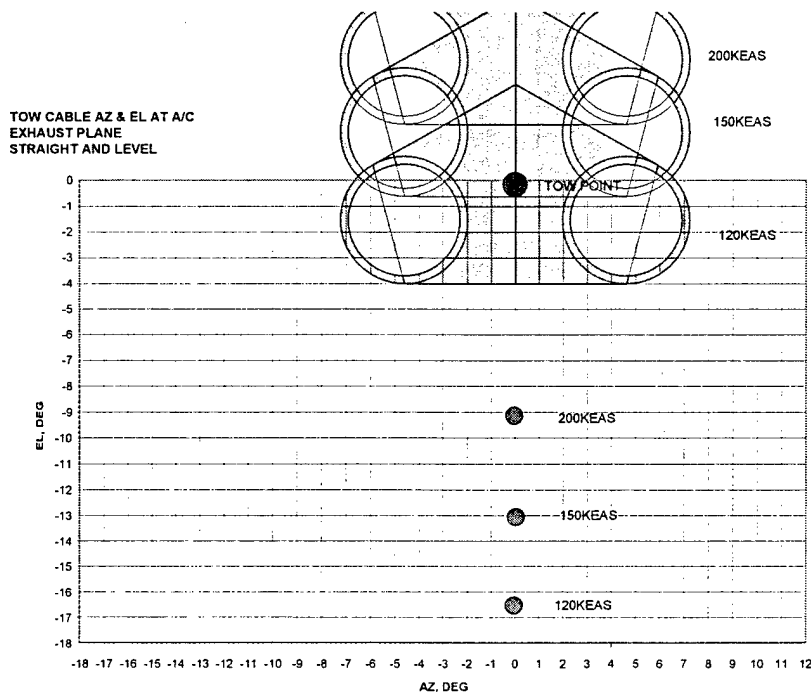

Figure 9. Cable and exhaust nozzle positions at the exhaust plane for straight and level flight at various airspeeds.

The greater tension due to the centripetal acceleration also causes the banner to droop less so the cable is higher at the exhaust plane. The predicted cable steady state position is shown for 30° AoB in figure 10 and 60° AoB in figure 11. The straight and level cable position is also shown for reference.

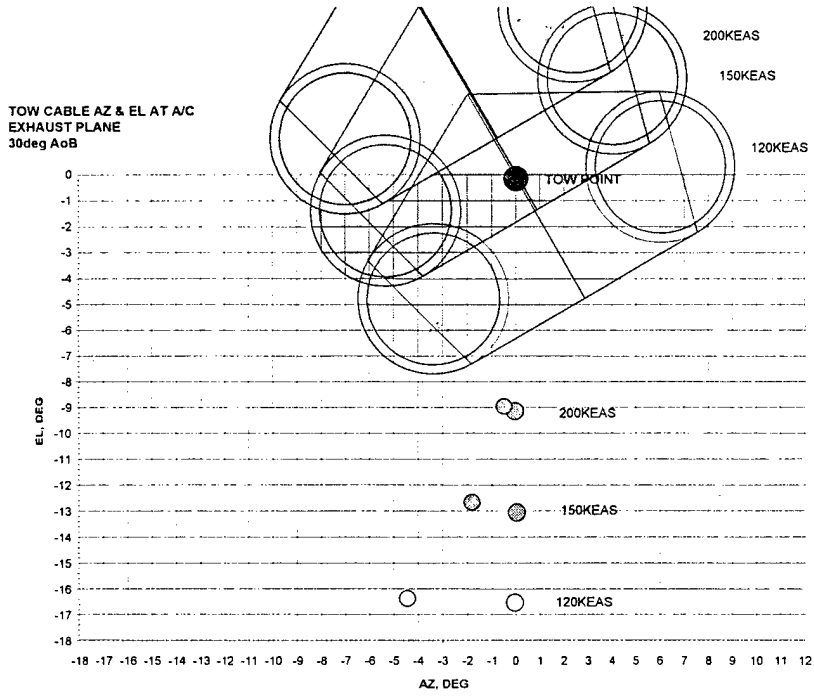

Figure 10. Steady-state position of the cable in the exhaust plane for level 30⁰ AoB turns.

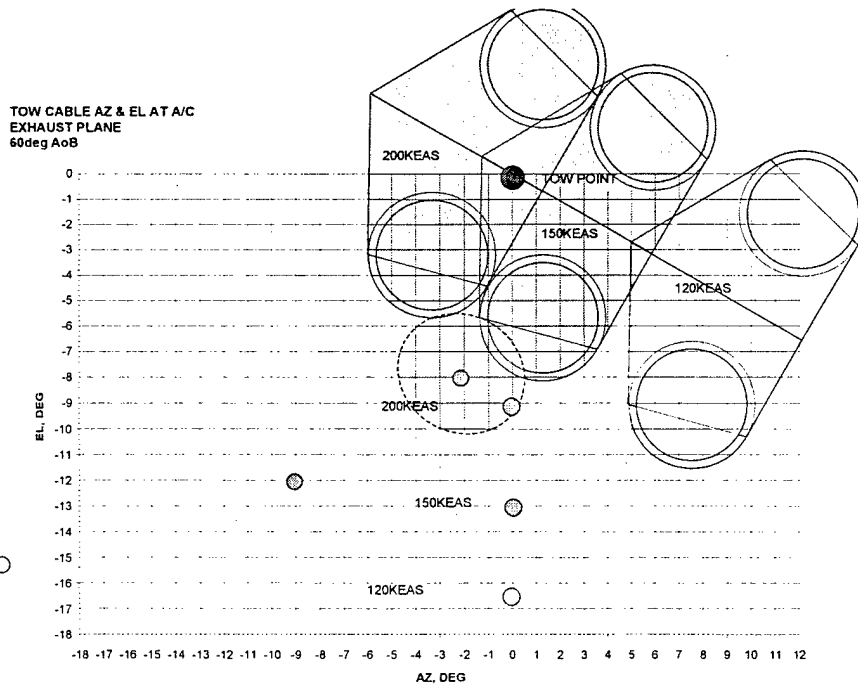

Figure 11. Steady-state position of the cable in the exhaust plane for level 60⁰ AoB turns.

Although the analysis is only for steady-state, comparing the location of the cable for turn and straight and level gives a rough estimate of the dynamics for a very smoothly initiated turn. In this case only the lowest dynamic mode of the cable motion will be excited and the motion will be approximately harmonic about the equilibrium position. The amplitude would be that which causes the motion to pass through the initial condition, i.e. the straight and level point. Since the lateral and vertical motion will have different periods, the locus of the cable will be within an ellipse as shown in figure 11 for the 200KEAS case. This indicates that the cable could come near the exhaust, but it does not predict that it would actually enter the exhaust stream.

At 150KEAS the tensile load in the cable near the aircraft is 390lb. In a steady-state turn at a 60° AoB this increases to 460lb. If the turn is initiated suddenly, relative to the lowest natural frequency of the cable/banner system, the load will overshoot the steady-state so that the peak load will be $460 + (460-390) = 530\text{lb}$.

Dynamic Analysis

A more abruptly initiated turn can excite higher modes of the cable/banner system. The second computer simulation models the system dynamically so as to predict the motion for an abrupt turn. This Cable Body Aerodynamic Simulation (CBAS) was developed for the U.K. Ministry of Defense. The U.S. Army targets group, AMCOM, at Huntsville, AL, has a licensed copy of CBAS. In support of this engineering investigation, Don Ferguson, modeled the cable/banner system response to an abrupt turn at airspeeds of 120KEAS, 150KEAs, and 200KEAS. In each simulated operation a turn of 180° was made; starting and ending with straight and level flight. Bank angles of 30° and 60° were modeled. The analysis is included as Appendix C. The analysis also addressed the aircraft angle of attack and the location of the aircraft exhaust relative to the tow path, but these were based on some erroneous assumptions about the tow point on the aircraft; so the exhaust point locations indicated in Appendix C are wrong. These were recalculated and added to the cable position plots of Appendix C in the following figures.

TOW CABLE AZ & EL @ A/C
30 DEG BANKED TURN @ 120 KEAS

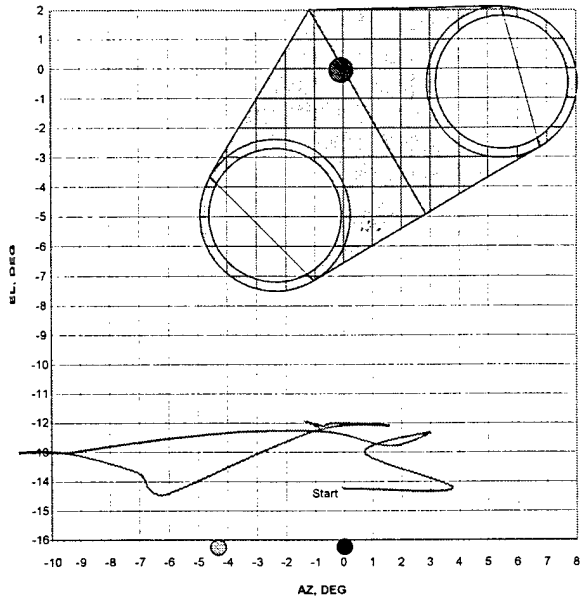

Figure 12. Cable position at the exhaust plane as predicted by CBAS for 30⁰ AoB at 120KEAS.

TOW CABLE AZ & EL AT A/C
30 DEG BANKED TURN @ 150 KEAS

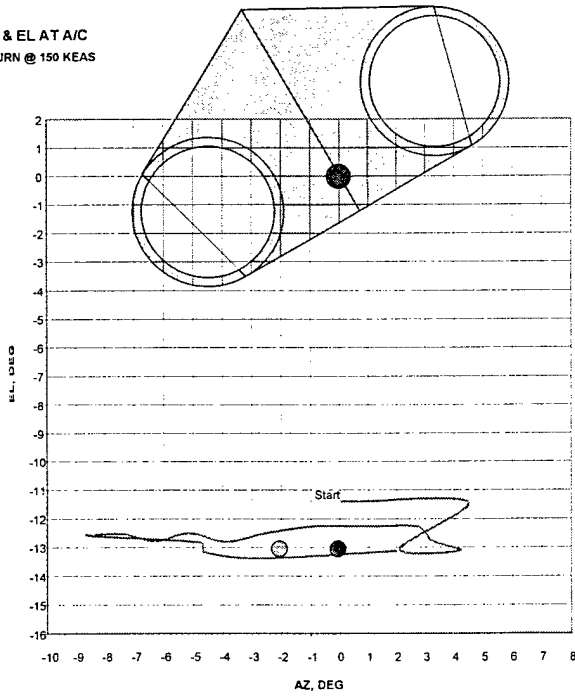

Figure 13. Cable position at the exhaust plane as predicted by CBAS for 30⁰ AoB at 150KEAS.

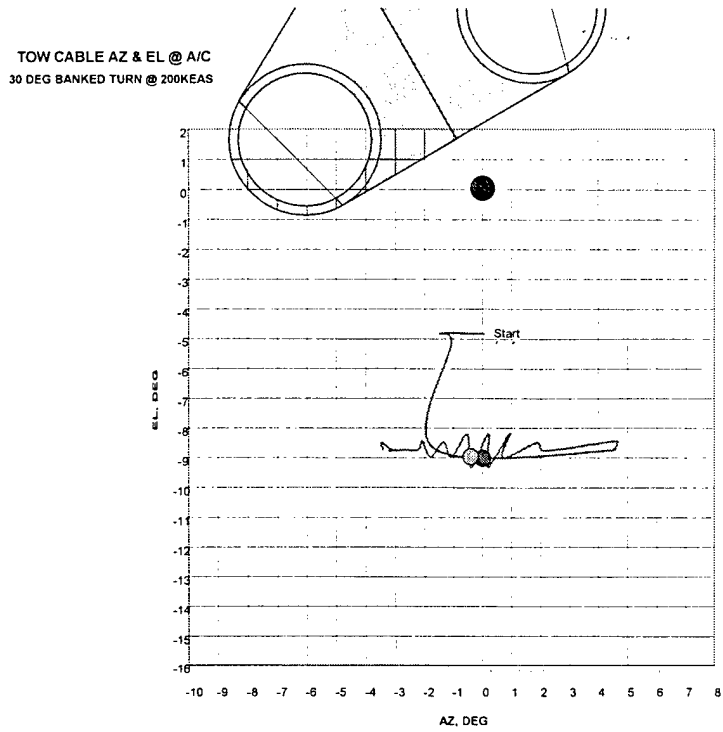

Figure 14. Cable position at the exhaust plane as predicted by CBAS for 30⁰ AoB at 200KEAS.

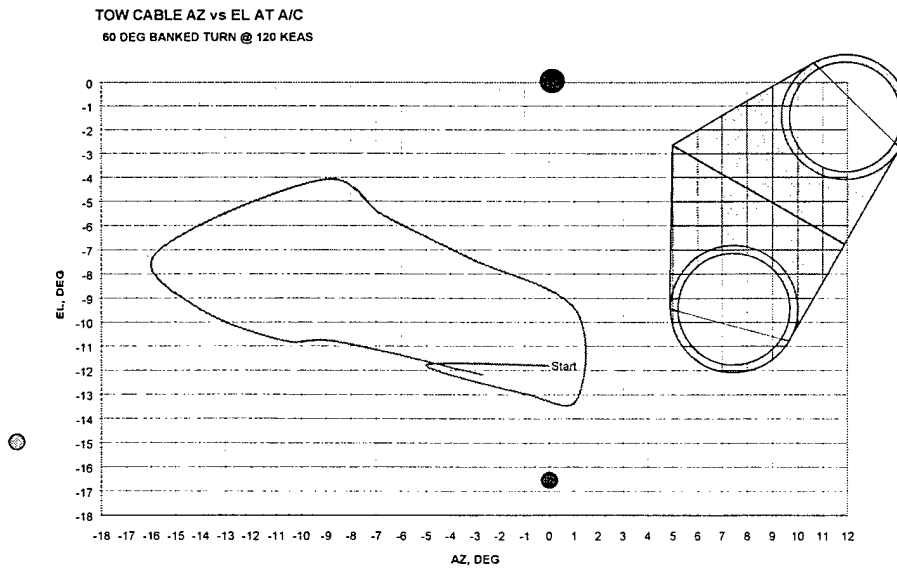

Figure 15. Cable position at the exhaust plane as predicted by CBAS for 60⁰ AoB at 120KEAS.

TOW CABLE AZ & EL AT A/C
60 DEG BANKED TURN @ 150 KEAS

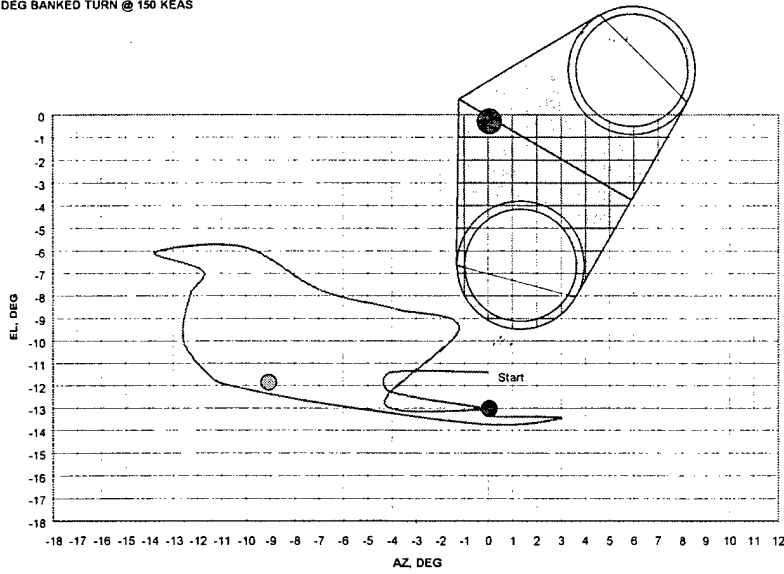

Figure 16. Cable position at the exhaust plane as predicted by CBAS for 60⁰ AoB at 150KEAS.

TOW CABLE AZ & EL AT A/C
60 DEG BANKED TURN @ 200 KEAS

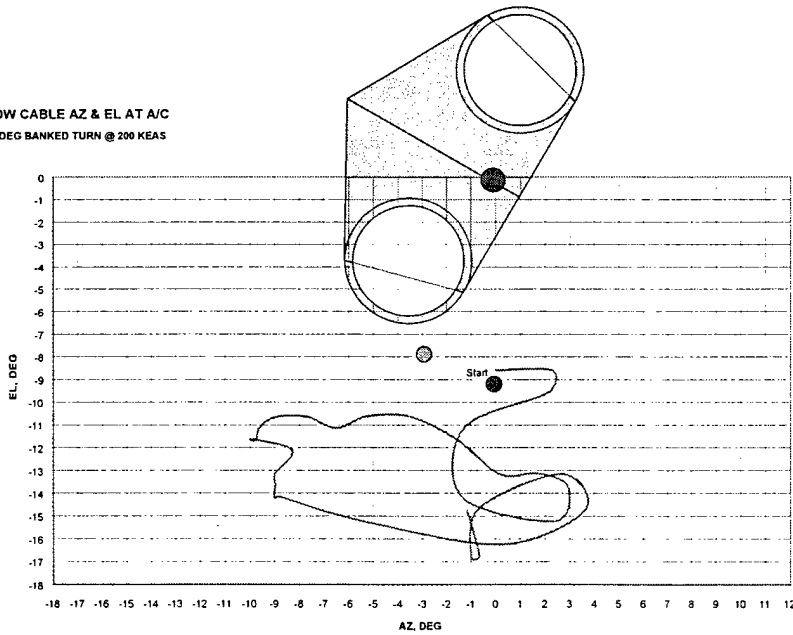

Figure 17. Cable position at the exhaust plane as predicted by CBAS for 60⁰ AoB at 200KEAS.

Note that in these figures the cable motion is very complex. It does not even start in the same direction as the maneuver begins for different AoB at the same speed. Since the motion seems to

be sensitive to the initial conditions, the details of the motion may be dependent on the numerical approximations that are inherent in a computer simulation.

Plotting the same data in terms of cable angle versus time shows, as in figure 18, shows that the systems natural frequency (lowest mode) is about 6seconds. This mode is excited in the CBAS simulation because an abrupt turn was assumed. This mode produces a 'crack-the-whip' effect so that the peak tensile load almost doubles – from 190lb straight and level to 345lb just after initiating the turn, as shown in figure 19. However, these load values are not credible since the steady-state load, before entering the turn should have been 380lb, as noted in the Appendix. These inconsistencies in the CBAS analysis make all of the results suspect.

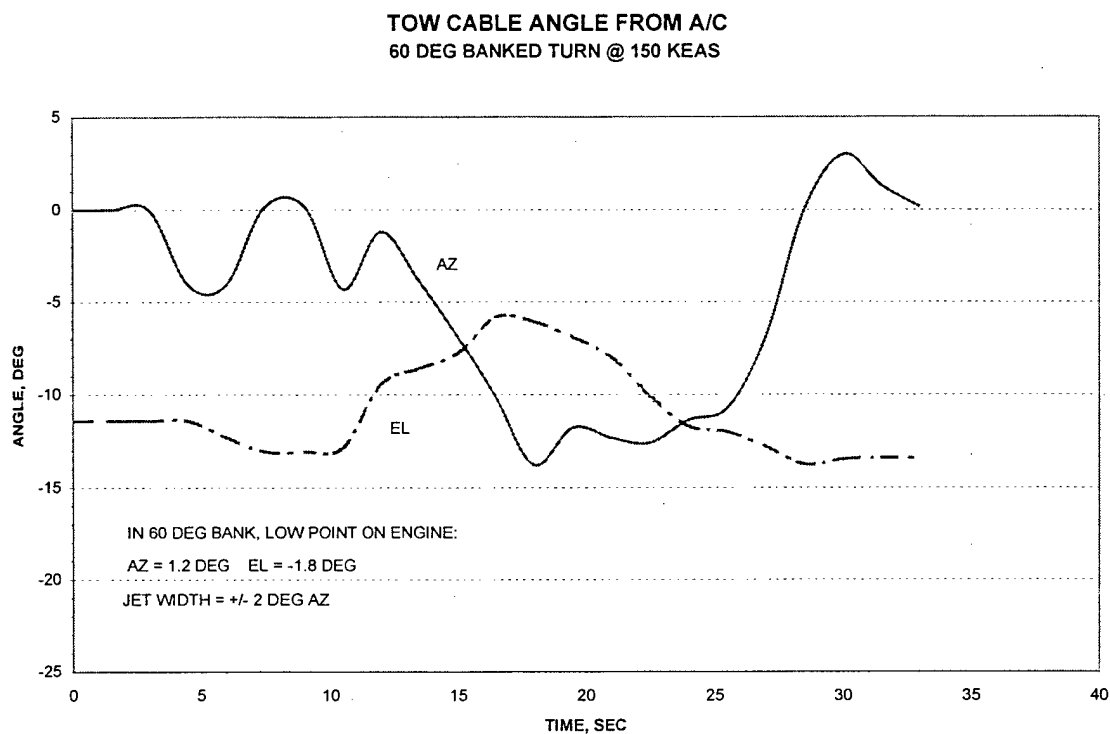

Figure 18. Cable angle at the two point relative to the tow point velocity vector versus time.

CABLE TENSION AT A/C IN TURN
150 KEAS, 60 DEG BANKED TURN

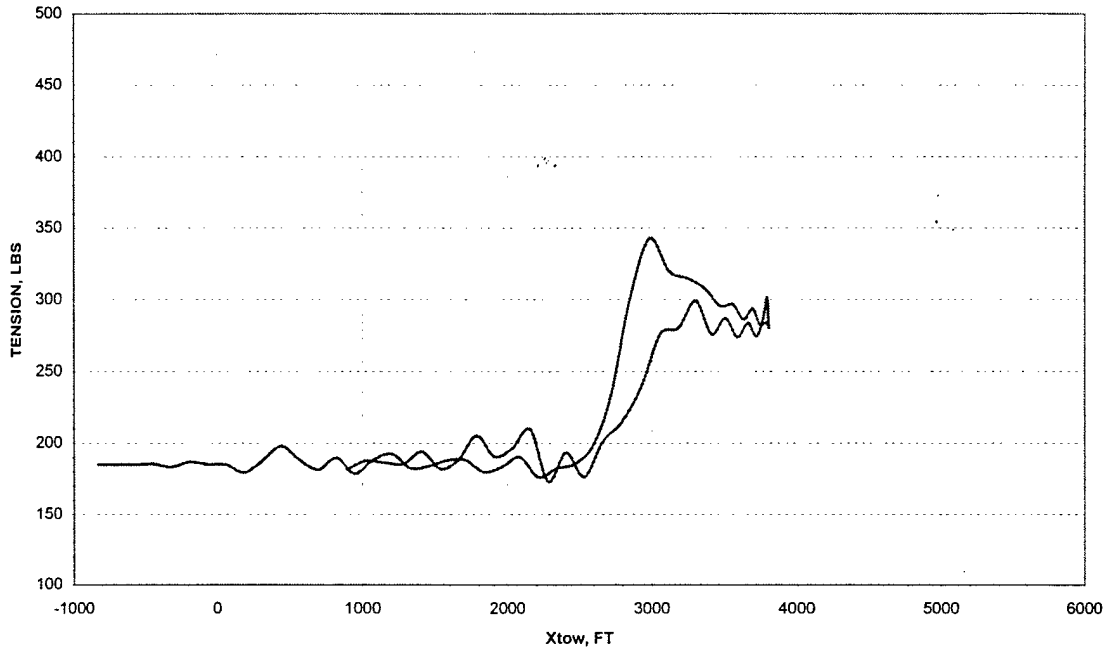

Figure 19.. Tow cable tension at the tow point as a function of down-range position.

DISCUSSION

The Proximate Cause

Inspection of the broken cables and the circumstances clearly indicate that the proximate cause of the cable failures was heating by the aircraft exhaust in combination with tensile load. This is supported by:

1. The discoloration of the cable near the break.
2. The location of the break just aft of the exhaust plane.
3. The necking of the wires adjacent to the breaks and the conical break surfaces.
4. The laboratory analysis of the material which found that the cables strength could be reduced below the load by the exhaust heat.
5. The report that at least three of the four failures occurred as or just after the tow aircraft entered a turn with an angle-of-bank between 45° and 60° .
6. The fact that the armor was broken at a different point along the cable than were the load carrying wires, indicates that stress due to contact with a part of the aircraft was not a factor in the failure.

It was expected that computer simulations of the cable and tow aircraft would determine exactly which conditions would cause cable breakage. However, this was not the case. The steady-state and quasi-steady-state simulation indicated that the cable would come very near and possibly enter the exhaust in a 60° AoB turn at 200KEAS. But this was a higher airspeed than that used in the target banner presentation. At lower speeds of 120 and 150KEAS the computer simulation indicated the cable would not enter the exhaust.

The dynamic simulations using CBAS also indicated a close approach of the cable to the exhaust for a 60° AoB at 150KEAS. But the simulation also predicted complex behavior of the cable that depended on the abruptness of initiating the turn and it was inconsistent in its prediction of the initial cable position and load during the approach to the turn. This cast doubt on the accuracy and numerical stability of the simulation. It should be noted that this simulation was developed by the U.K. Ministry of Defense to predict the path of a tow body rather than the cable position. It models the cable rather crudely as consisting of only six segments. For these reasons the CBAS predictions cannot be considered definitive. However, the predicted position comes so close to the exhaust that it may be only the errors and approximations in the program that prevented it from predicting an intersection of the cable and exhaust.

CORRECTIVE ACTIONS

The Commanding Officer of VT-9, noting the visible evidence, ordered that turns be limited to 30° AoB until the cause of the cable failures was determined. This is the simplest corrective action and so far as can be determined it will be effective. If a 30° AoB is too restrictive, the simulations indicate that a 45° AoB would also be safe, with the caveat that the initiation of the turn should be gradual, i.e over a period of several seconds.

Another possible corrective action, suggested by Jerry Fox and shown in figure 7, is to provide multiple cables in the section of cable that may come into the exhaust. As shown in the figure, the cables would inevitably be of slight different lengths so that the load would not be shared equally; rather one would carry almost all of the load while the other two were lightly loaded. If a maneuver brought the cables into the exhaust the heavily loaded cable would fail first. It is possible that the other two would also fail in the same incident. If all three were in the exhaust together they would all be heated and weakened. When the heavily loaded cable failed there would be a sudden transfer of load to the next longest cable. A suddenly applied load in an elastic systems results in twice the stress of the same load gradually applied. Hence the next longest cable might very well fail and then also the third and last cable. A more complex joining of the multiple cables to the single cable, such as using a wiffle tree, could ensure the load was evenly distributed among them.

The cable material is carbon steel which gains its strength from cold working when it is drawn into wire. As such it loses about 90% of its strength at 1800F. There are other common steels containing nickel and chromium which retain a much greater portion of their strength at elevated temperatures, see reference [4]. However, they start out with much lower room temperature strength so at 1700F there is very little advantage. Some more exotic cobalt based alloys with chromium and nickel retain greater strength at 1700F; but even so they would have to be formed into a larger diameter cable to provide a margin against the predicted load. They would also be very expensive. For these reasons, use of a cable material resistant to the high temperature is not recommended as a practical solution.

Another possible corrective action is to provide the cable with some shielding insulation in the region subject to exhaust impingement. An insulative layer of rock wool or similar fibrous insulation would protect the cable from being raised to high temperatures during brief exposures. The insulation would have to be protected from abrasive damage during drag-off from the runway and from aerodynamic forces. This protection would take the form of some metal ribbon or wire wrapped around the insulation as the armor ribbon is wrapped around the current cable.

CONCLUSION

The tow cable failures experienced by VT-9 resulted from engine exhaust impingement on the tow cables while the T2C tow aircraft was executing a turn. This failure mode can be avoided by limiting the the aircraft to a 30° AoB during turns or by limiting the aircraft to 45° AoB turns and initiating the turns gradually, over a period of several seconds.

If limitations on the sngle-of-bank are too onerous, failures can also avoided by providing an insulative wrap over the portion of the cable subject to exhaust impingement. Use of multiple leaders or high-temperature materials are not promising solutions.

REFERENCES

- [1] Target Systems Engineering Investigations & Corrective Action Process, Rev 1, 21 Nov 1997
- [2] Military Specification Strand, Wire, Armored Steel MIL-DTL-5765G, Notice 1, 16 June 1997
- [3] NAVAIR 28-10a-23, NATOPS TDU-32A BANNER TARGET
- [4] Aerospace Structural Metals Handbook, V. Weiss & J. G. Sessler Ed. Syracuse Univ Press 1963

APPENDIX A.
LABORATORY ANALYSIS OF TOW CABLE



NAVAL FACILITIES ENGINEERING SERVICE CENTER
Port Hueneme, California 93043-4370

Special Publication

SP-2099-SHR

TOW BANNER STEEL LEADER CABLE FAILURE ANALYSIS

by

Daniel R. Polly

November 2000

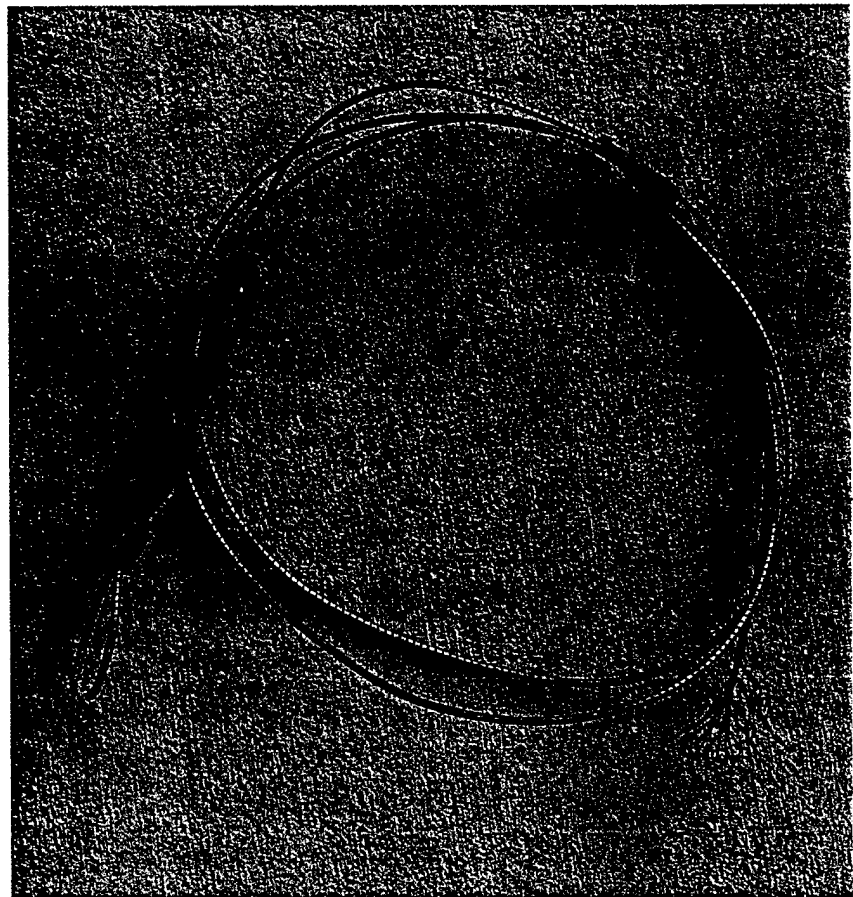

Distribution authorized to U.S. Government agencies and their contractors; administrative/operational use; November 2000.
Other requests for this document shall be referred to Naval Facilities Engineering Service Center.

TOW BANNER STEEL LEADER CABLE FAILURE ANALYSIS

1.0 BACKGROUND

1.1 Tasking.

Three lengths of cable were delivered to NFESC for failure analysis. The investigation included visual and light-optical microscopic examination, electron microscope fractography, chemical analysis, metallography, microhardness testing, and tensile testing. Although not included in the proposed work, elevated temperatures tests were also done to better characterize cable behavior.

1.2 Cables.

The cable received consisted of the three lengths shown in Figure 1. Two of the cables were from two separate incidents where the tow cable broke in flight. The two lengths investigated were the sections remaining attached to the aircraft after failure. The third length of cable was taken from a spool of unused cable. NFESC was informed that failure of the cables occurred at a location where it is suspected that the cables experienced temperatures from 1500 to 1800 °F for 10 to 20 sec when swung into the engine exhaust. NFESC was also informed that the working load on the cables is less than 500 lb.

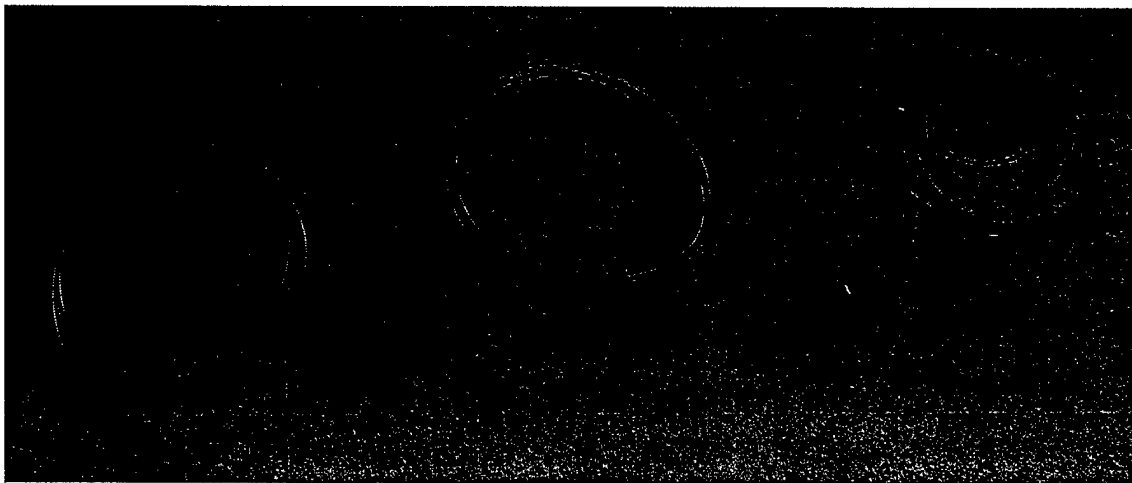

Figure 1. From left to right; new cable, and two failed cables, respectively A,B, and C.

For this investigation the new cable was designated cable A. The failed cables were designated B and C as depicted in Figure 1.

2.0 EXAMINATION

2.1 Visual examination.

Fracture of the individual wires of cable B occurred at approximately 14 feet from the loop end of the cable. The wires in cable C failed at approximately 15 feet from the loop end. A dark deposit or residue was observed on both cables near the failure ends (Figure 2).

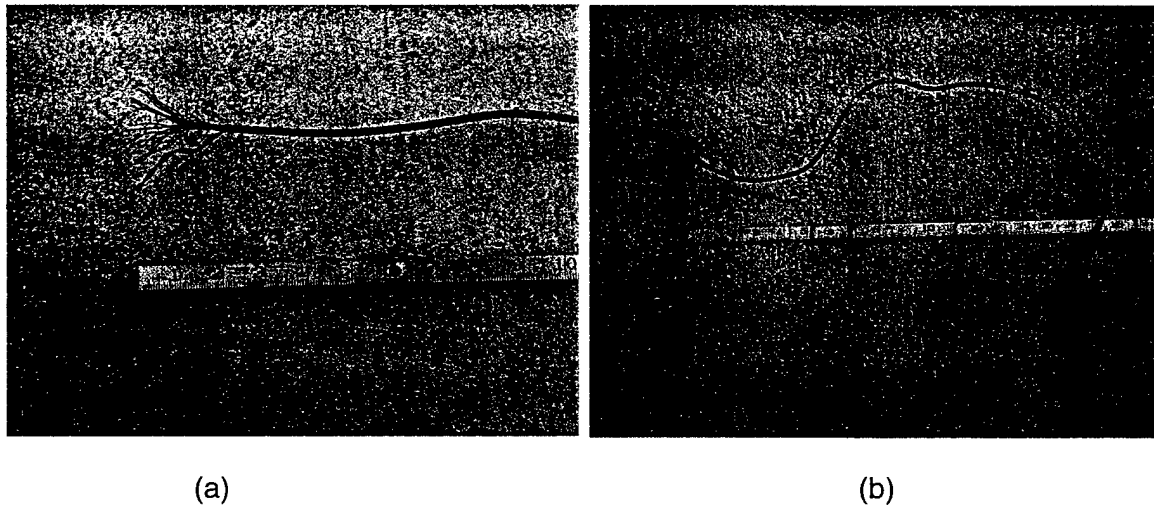

Figure 2. Cable B (a), and cable C (b).

2.2 Microscopic examination.

Cross sections revealed similar construction for all cables. As depicted in Figure 3, a central core wire is surrounded by six wires of the same diameter, which are themselves surrounded by alternating 6 larger and 6 smaller diameter wires. A single flat wire is wrapped spirally around the strand.

As shown in Figure 4, the ends of individual wires in both cable strands appeared necked down when examined by light optical-microscopy.

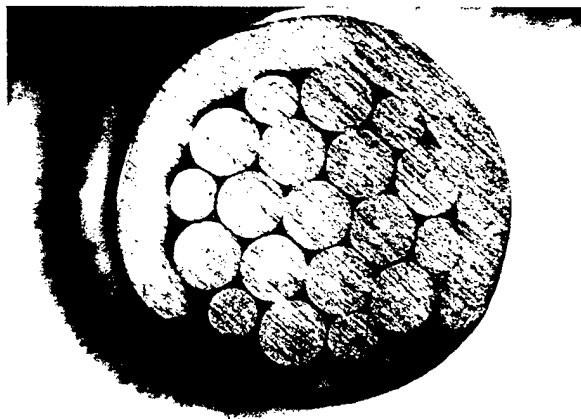
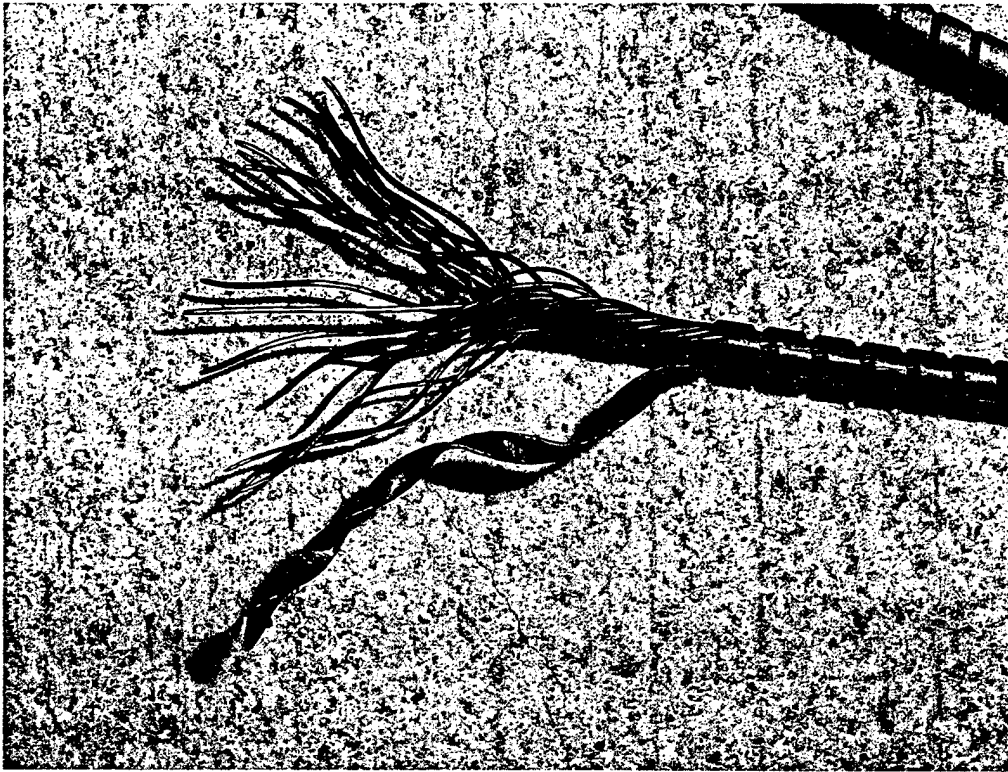
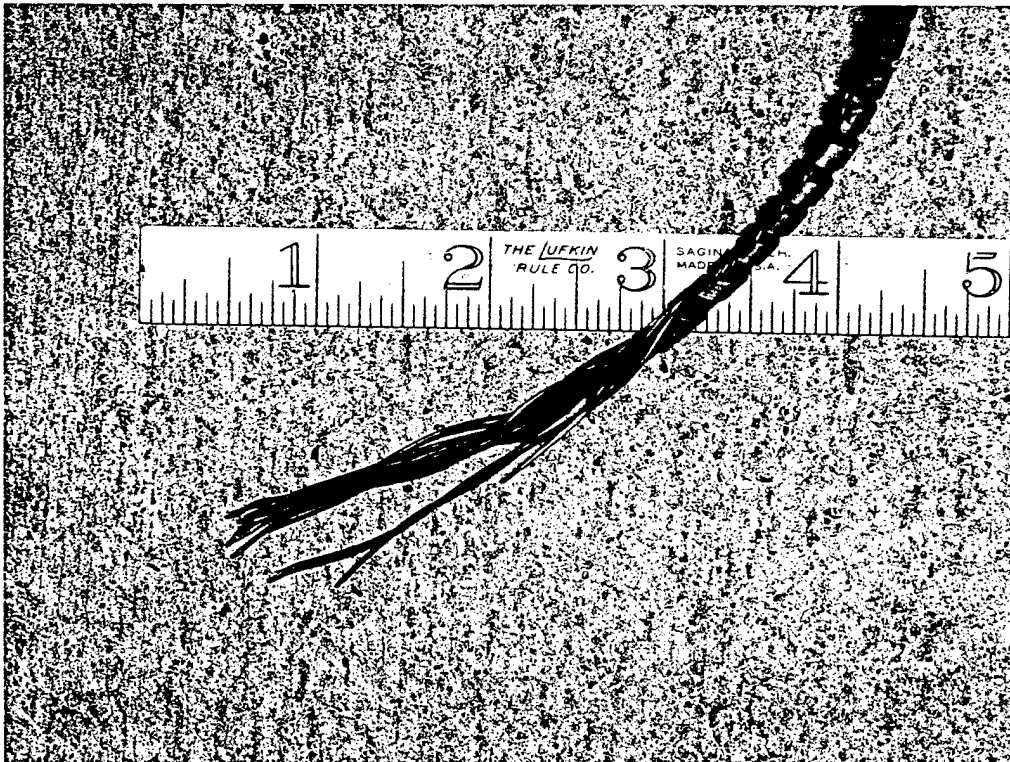

Figure 3. Cable construction.



(a)



(b)

Figure 4. Failure ends of cable B (a), and cable C (b)

2.3 Fractography.

Higher magnification of the surface by scanning electron microscopy (SEM) confirmed necking, and revealed cup and cone fractures typical of failure by tension overload. Figures 5, 6, and 7 consist of micrographs of large and small outer layer wires and an inner layer wire from cable B. Higher magnification of the fracture surface as in Figure 7b. revealed corrosion too severe for removal and further feature or fracture mechanism identification.

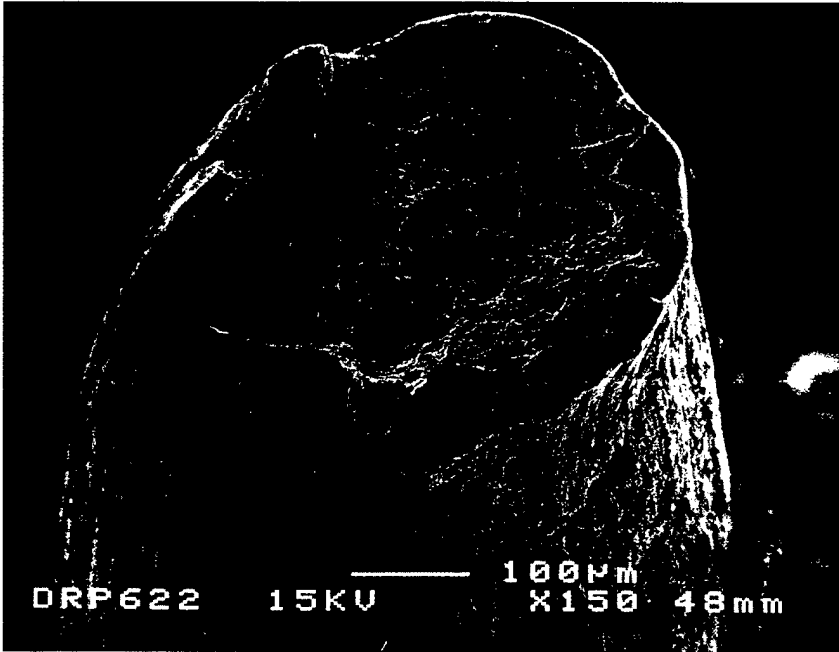

Figure 5. Large wire from outer layer of cable B.

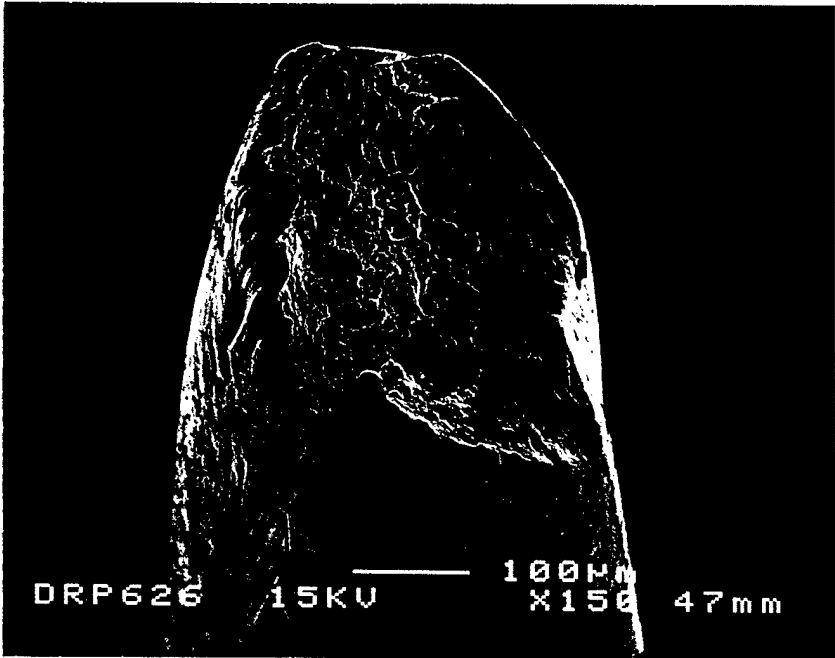
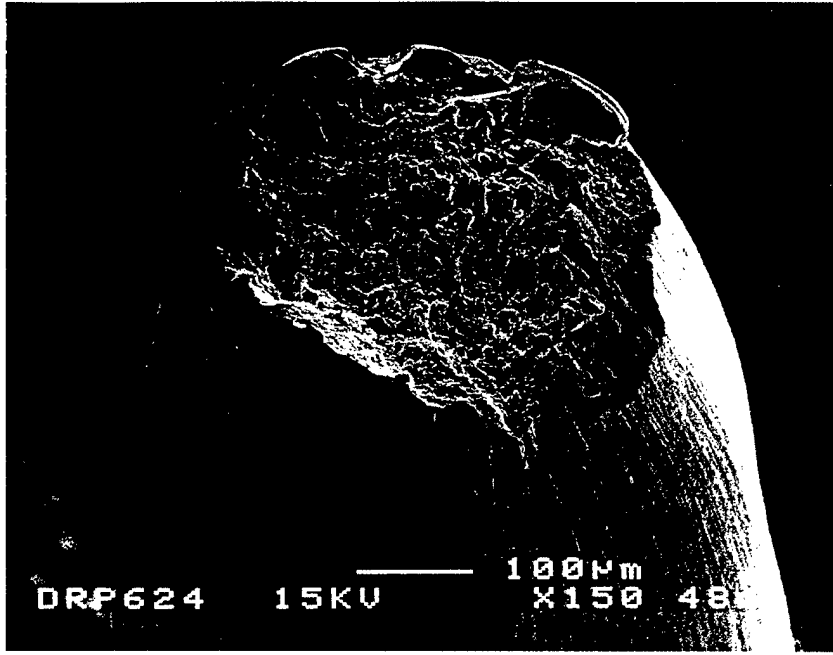
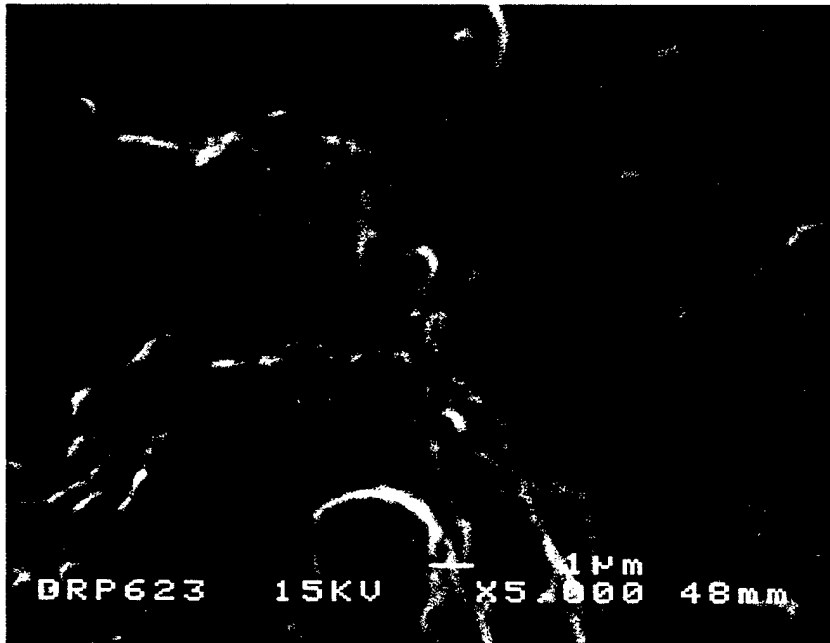

Figure 6. Small wire from outer layer of cable B.



(a)



(b)

Figure 7. Wire from inner layer of cable B (a), and corrosion on fracture surface (b).

For comparison, fractographs of the wire fractures from the tensile tests discussed below are presented in figures 8, 9.

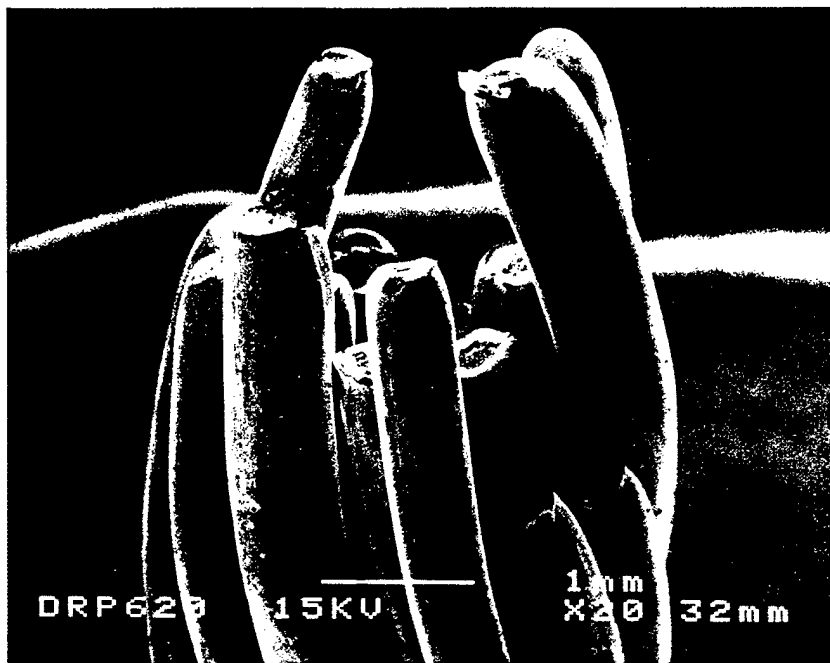
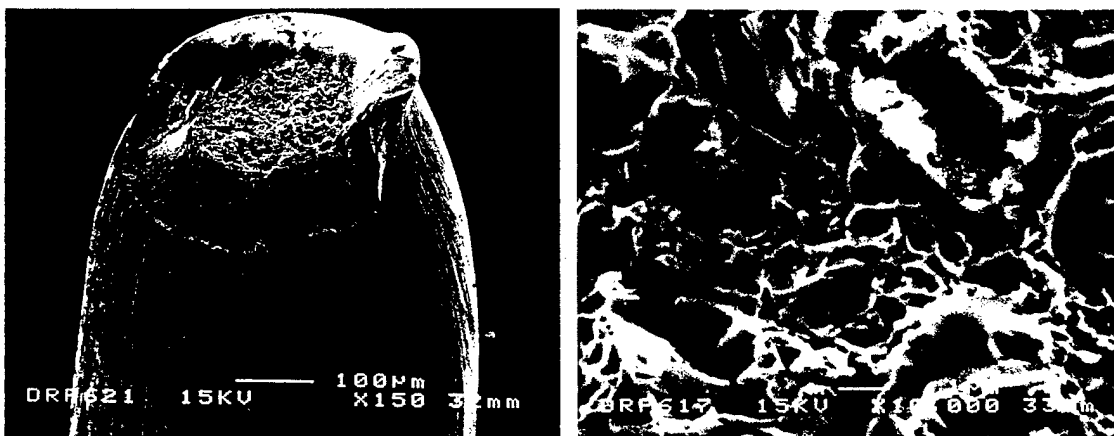

Figure 8. Fractured wires from cable A tensile test.



(a)

(b)

Figure 9. Cup and cone fracture (a), and microvoids (b) produced by tension overload.

2.4 Metallography

Figures 10, and 11 are micrographs of the cross sections shown in Figure 12. The labels in Figure 12 correspond to the following cables and cross section locations:

- A - unused cable A.
- B1 - cable B, 3.6 in. from failure end.
- B2 - cable B, 24 in. from loop end.
- C1 - cable C, 4.1 in. from failure end.
- C2 - cable C, 24 in. from loop end.

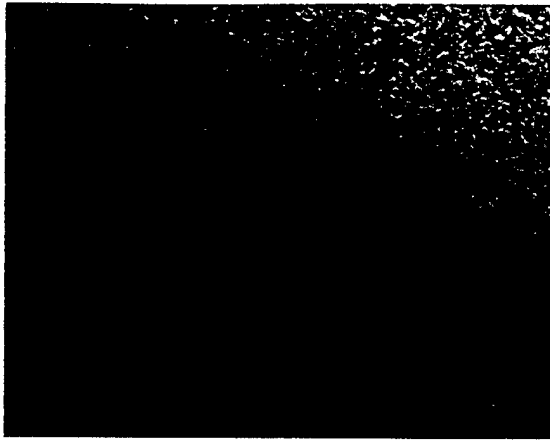

(a)



(b)

Figure 10. Microstructure of A (a), and B2 (b).

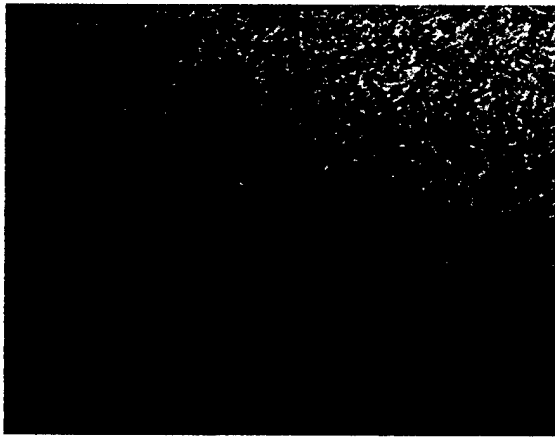

(a)

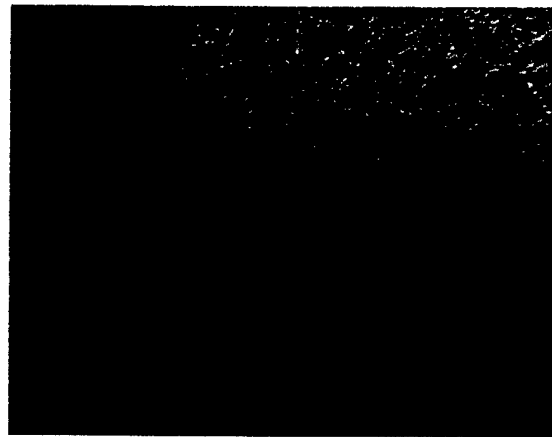

(b)

Figure 11. Microstructure of C1 (a), and C2 (b).

All cable sections exhibited a uniform cold drawn microstructure. The structure of B2 and C2 appeared finer than that of A and C1.

3.0 HARDNESS TESTS

Microhardness test were conducted with a Knoop indenter and 500 grams-force on five cross sections of the three cables. The five cross sections are shown in Figure 10. The results are presented in Table 1 and Table 2.

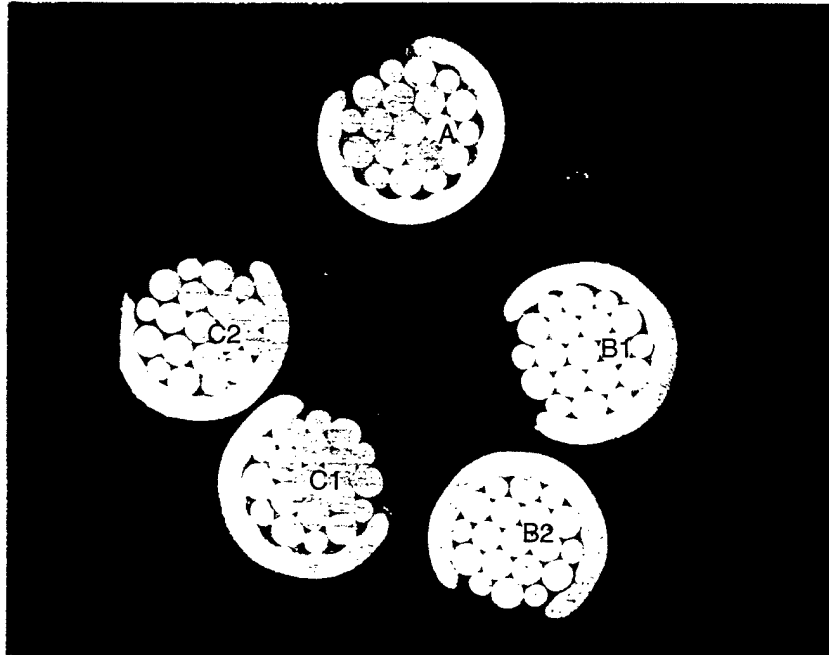

Figure 12. Cable cross sections for metallography and hardness tests.

Table 1. Microhardness Tests (HK₅₀₀).

Cable	A	B1	B2	C1	C2
Armor	319	321	337	336	391
Outer large	581	573	557	626	544
Outer small	598	615	544	609	549
Inner	568	583	553	573	535
Center	593	558	535	583	535

Table 2. Microhardness Tests (HK₅₀₀) Around Outer Layer of C2.

1 Outer large	609
2 Outer small	573
3 Outer large	583
4 Outer small	593
5 Outer large	531
6 Outer small	593
7 Outer large	593
8 Outer small	573
9 Outer large	593
10 Outer small	578
11 Outer large	620
12 Outer small	614

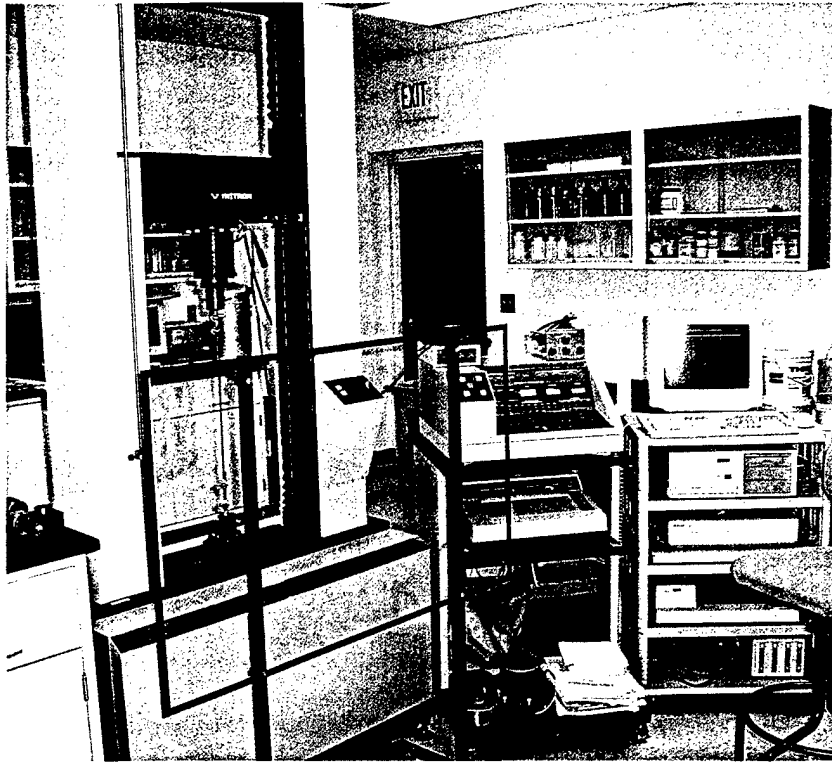

Figure 13. Tensile machine.

4.0 TENSILE TESTS

4.1 Ambient temperature.

4.1.1 Cable sections. Sections of the three cables were pulled to failure using an Instron Model 4206 tensile machine (Figure 13). Sections from both ends of cables B and C were tested. Results of ambient temperature tests are presented in Table 3.

Table 3. Ambient Temperature Tensile Tests

Cable	Location of Break	Load (lb.)
A	irrelevant	4051
A	irrelevant	3935
B	41 in. from loop end	3954
B	12.5 in. from failure	3360
C	43 in. from loop end	4017
C	13.5 in. from failure	3113

Test section were assembled with thimbles and clips as depicted in Figure 14 to give a test length of approximately 24 inches.

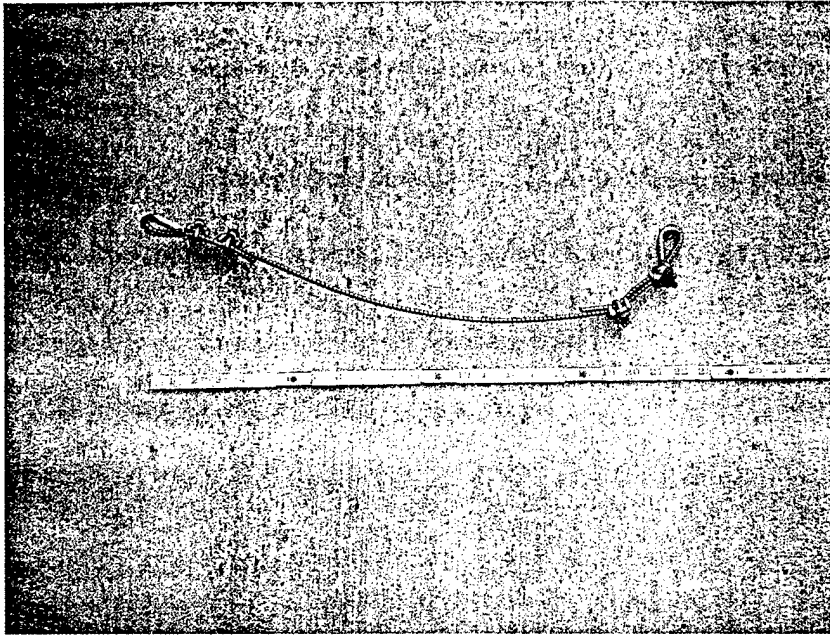
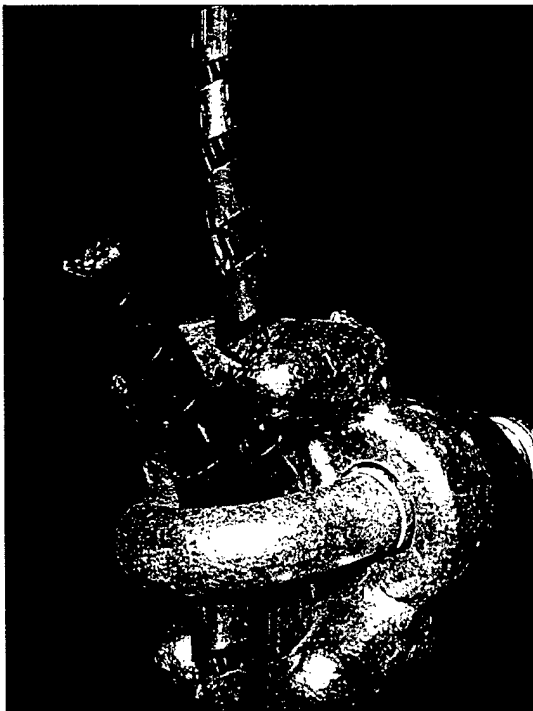
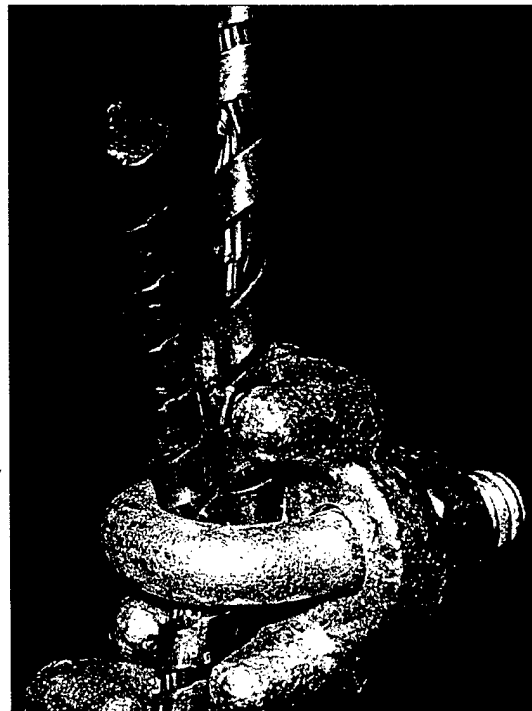

Figure 14. Tensile test assemble.

The sections of cable under test from the failure ends were at a distance from the failure. This was due to the length required by the thimble and clip assemblies for connection to the machine. In both ambient temperature tests of the failure ends, the cables broke just inside the inner clip of the failure end of the cable (Figure 15.)



(a)



(b)

Figure 15. Breaks in tensile test strand from failure ends of cables B (a), and C (b).

4.1.2 Individual wires. In order to better assess the strand strength nearer the failures, individual wires from cable C were pulled to failure. Table 4 presents the results of these tests. The smaller wires of the outer layer broke within the grips due to deformation cause by the grips themselves and their breaking loads should be considered minimum strengths. The larger wires broke between grips (Figure 16).

Table 4. Individual Wire Tensile Tests.

Wire	Location of Break	Load (lb.)
Outer large	1.3 in. from failure	180
Outer small	0.8 in. from failure	98
Outer small	0.4 in. from failure	107
Inner	1.8 in. from failure	174

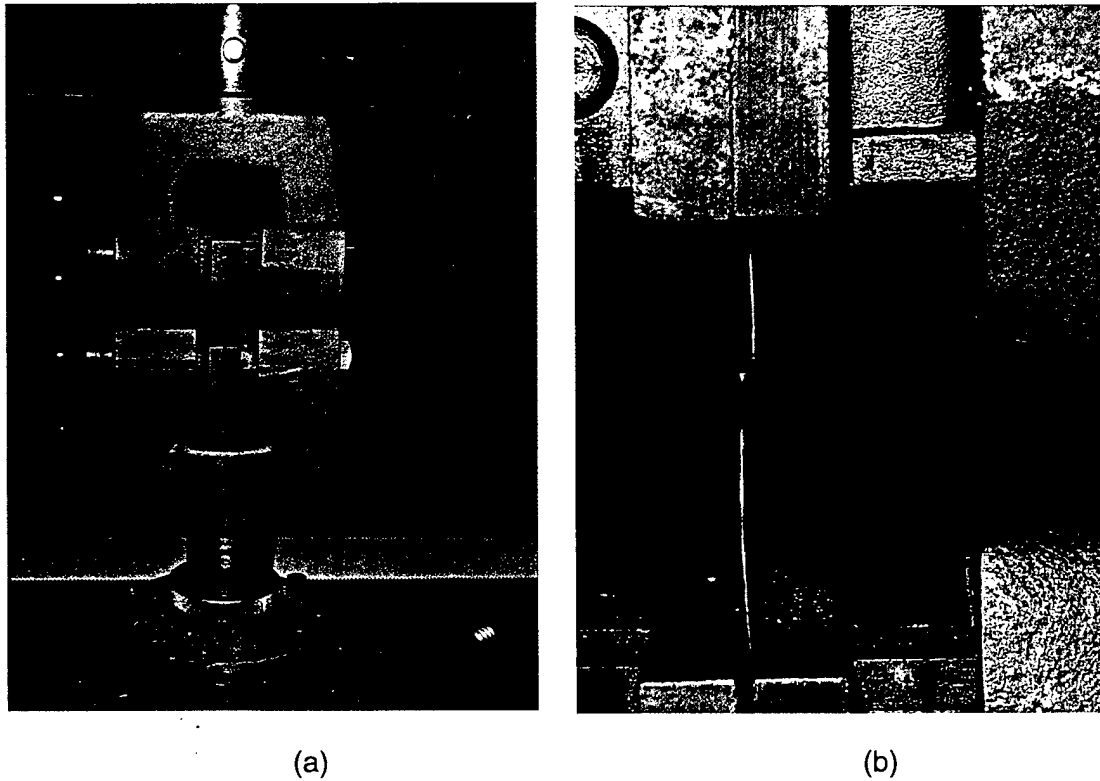

Figure 16. Tensile test of individual wires.

4.2 Elevated temperature.

Two type of tensile tests were conducted to evaluate the effects of elevated temperature on the cable. In one test a section of cable was heated, allowed to cool, and then tested. In the other, load was applied while a section of cable was heated.

4.2.1 Residual heating affect. A section of unused cable was placed in a muffle oven at a temperature of 1700 °F for approximately 15 seconds. The cable was allowed to cool to ambient temperature, fitted with thimbles and clips as in previous tests and then pulled to failure. Figure 16a shows the cable subsequent to heating. While in the oven the lubricant on the cable ignited, leaving a residue similar in appearance to that observed at the failure ends of cables B and C.

The cable broke at a maximum load of 2,170 lb. (Figure 16 b).

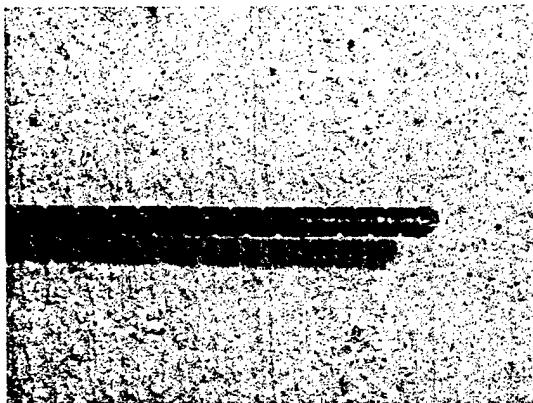

(a)



(b)

Figure 16. Heated cable residue (a), and tensile test break (b).

4.2.2 Load at elevated temperature. A section of unused cable was loaded while being heated. Figure 17 depicts the test configuration. A bunsen burner was adjusted so that the cable was at a position in the flame of where the measured temperature was approximately 1700 °F (+/- 100 °F). The Instron tensile test machine employed for the the test is a constant strain rate machine. Therefore the load applied was not constant, but varied as the strain rate was adjusted between 1.0 and 0.1 in. per min, as the test progressed. Figure 18 shows the load with time. A maximum load of 494 lb. was attained after approximately 39 seconds.

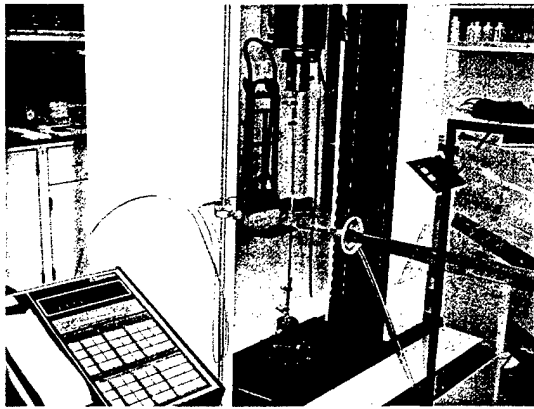

(a)

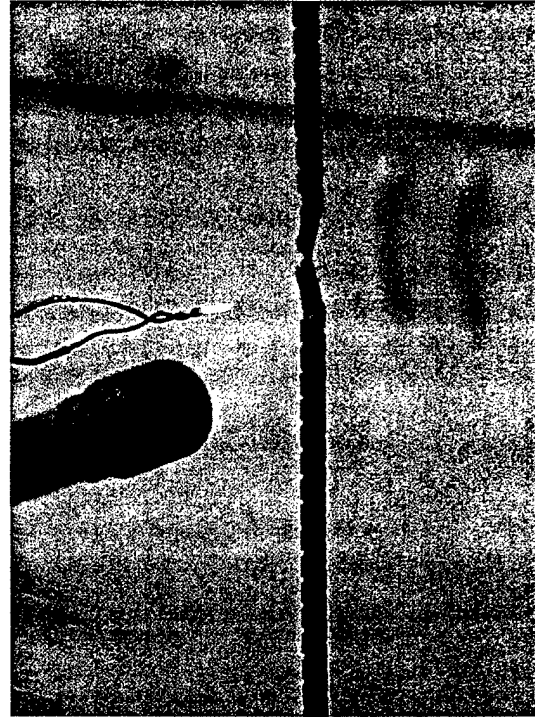

(b)

Figure 17. Elevated temperature test configuration.

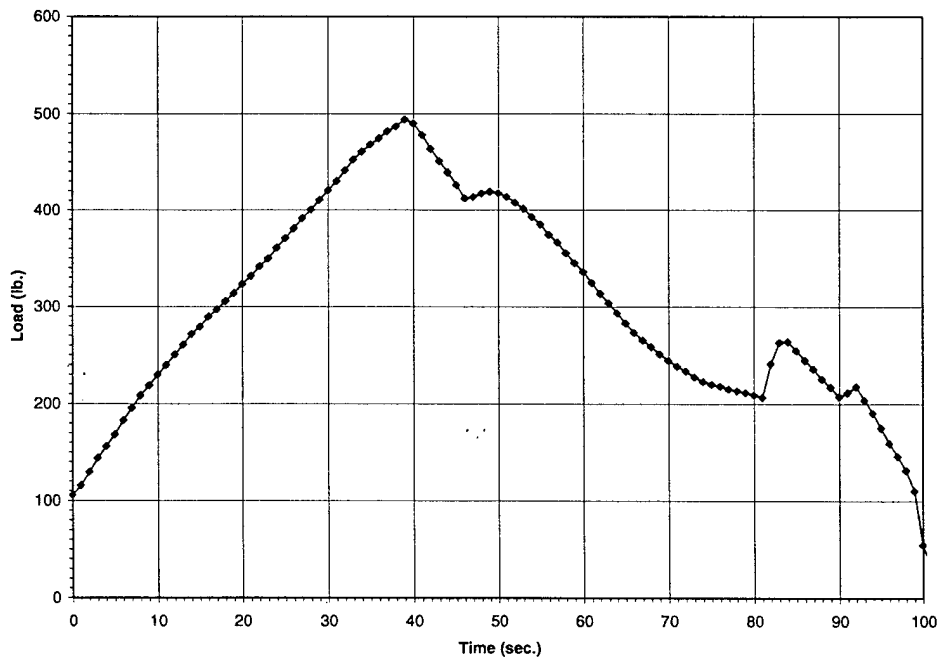

Figure 18. Load at elevated temperature.

5.0 DISCUSSION

5.1 Cable conformance to specification.

5.1.1 Construction. Presumably, the three lengths of cable were procured to some revision of MIL-?-5765. MIL-DTL-5765G is enclosure 1. Although the details of cable construction were not considered in this investigation, no discrepancies were found. The strands consist of 19 individual wires of three different sizes as depicted in Figure 1 of the specification. One flat wire is wrapped around the strand as depicted in Figure 2 of the specification.

5.1.2 Tensile strength. The section of new cable and the sections of failed cable taken from the loop ends met (within a few pounds) the 4,000 lb. tensile strength specified for the "Size 11/64-inch diameter" classification.

5.1.3 Materials. The composition requirement is limited to specification that the cable shall be carbon steel capable of meeting the requirements of the specification. X-ray spectroscopy did not indicate the presence of alloying elements. Chemical analysis for carbon content and minor continents is being conducted, but is not yet complete, for inclusion in this report.

5.2 Examination.

Visual examination, light-optical microscopy, and electron microscope fractography all indicate that the individual wires of the failed cables fractured by tension overload. Metallography indicates subtle differences in the microstructure between the loop and the failure ends of the cables that are no doubt the result of thermal variations. Not only is the engine exhaust a source of high temperature, the low temperature and motion at altitude will provide rapid cooling.

5.3 Hardness tests.

A decrease in hardness would normally be expected for wire exposed to elevated temperature. However, only a small reduction in average hardness (of approximately 40 HK_{500}) was found at the failure ends of the cables. This indicates short exposure time and perhaps rapid cooling. Variations in hardness measurements around the outer wire layer, at a failed end, were 89 HK_{500} .

5.4 Tensile tests.

5.4.1 Ambient temperature. Tensile tests on full cable sections indicate a reduction in strength of approximately 20% (to 3,200 lb.) at a distance of 13 inches from the failure ends. Test of individual wires sections closer to the failure indicate a slightly lower strength. As Table 5 shows, a load capacity of approximately 2,900 lb. was calculated using the breaking loads of individual wires. This far exceeds the stated working load of less than 500 lb.

Table 5. Load Capacity Based On Wire Strength.

Wire	Load	Number	Total Load
Outer large	180	6	1080
Outer small	174	6	1044
Inner	107	7	<u>749</u>
			2873

5.4.2 Elevated temperature. Elevated temperature test were beyond the scope of work for this investigation. Stress rupture tests should be made over a range of temperatures with fixed loads. However, the limited tests that were performed indicate the reduction in strength that can occur with short term exposure of high strength cold drawn wire to elevated temperature.

Calculation of wire tensile strength from the cable breaking load, and measured wire diameters gives a strength of 312,000 psi (Table 6). This high of strength requires a high carbon content and a large reduction through cold work.

Table 6. Calculated Tensile Strength.

Wire	Diameter	Number	area
Outer large	0.032	6	0.0048
Outer small	0.024	6	0.0027
Inner	0.031	7	<u>0.0053</u>
			0.0128
	Breaking load	4000	
	Tensile strength		312,000

The engine exhaust temperature is well above the austenitizing temperature. At temperatures above 1300 °F recovery (of properties prior to cold work) and recrystallization is rapid. Fifteen seconds at 1700 °F is sufficient to reduce the cable breaking strength to 2170 lb. after air cooling to room temperature. This corresponds to a tensile strength of 170,000 psi based on the wire areas of Table 6.

Much greater reductions in strength are realized when loading at the elevated temperature. A load of 500 lb. can not be maintained for 40 seconds at 1700 °F.

6.0 CONCLUSIONS

Failure occurred by tension overload (or stress rupture). The strength of the broken cables was reduced by elevated temperature. If the working load is less than 500 lb., the remaining strength of both the broken cables is sufficient to carry the working load at "ambient" temperatures. Therefore, the failure must have occurred while at elevated temperature, or at some time the cables were subjected to a load in excess of 2,500 lb.

NOTICE OF INACTIVATION
FOR NEW DESIGN

INCH-POUND

MIL-DTL-5765G
NOTICE 1
16 JUNE 1997

MILITARY SPECIFICATION

STRAND, WIRE, ARMORED STEEL

This notice should be filed in front of
MIL-DTL-5765G dated 05-JAN-96.

MIL-DTL-5765G is inactive for new design and is no longer used except for
replacement purposes.

Preparing activity:
DLA-IS

(Project 4010-0220)

AMSC N/A

FSC 4010

DISTRIBUTION STATEMENT A. Approved for public release; distribution is unlimited.

INCH-POUND

MIL-DTL-5765G
5 January 1996
SUPERSEDING
MIL-S-5765F
14 June 1990

DETAIL SPECIFICATION

STRAND, WIRE, ARMORED STEEL

This specification is approved for use by all Departments and Agencies of the Department of Defense.

1. SCOPE

1.1 Scope. This specification covers armored steel tow target cable. The terms "strand" and "cable" as referred to in this specification are defined in 6.3.3 and 6.3.1.

1.2 Classification. Cable shall be of the following sizes, as specified (see 6.2):

Size 1/8-inch diameter, 2,160-pound tensile strength

Size 11/64-inch diameter, 4,000-pound tensile strength

2. APPLICABLE DOCUMENTS

2.1 General. The documents listed in this section are specified in sections 3 and 4 of this specification. This section does not include documents cited in other sections of this specification or recommended for additional information or as examples. While every effort has been made to ensure the completeness of this list, document users are cautioned that they must meet all specified requirements and documents cited in sections 3 and 4 of this specification, whether or not they are listed.

2.2 Government documents.

2.2.1 Specifications, standards, and handbooks. The following specifications, standards, and handbooks form a part of this document to the extent specified herein. Unless otherwise specified, the issues of referenced documents are those in effect at the time of solicitation. Information regarding the latest issue of government documents and adopted non-government documents can be obtained from the Department of Defense Index of Specification and Standards. (see 6.2).

STANDARDS

MILITARY

MIL-STD-130 - US Military Property, Identification Marking of
MIL-STD-831 - Test Reports, Preparation of

(Unless otherwise indicated, copies of the above specifications, standards, and handbooks are available from Standardization Document Order Desk, 700 Robbins Avenue, Building 4D, Philadelphia, PA 19111-5094.

Beneficial comments (recommendations, additions, deletions) and any pertinent data which may be of use in improving this document should be addressed to: San Antonio Air Logistics Center, SA-ALC/TILDD, Bldg 207, 306 Tinker Drive, Kelly AFB, TX, 78241-6915 by using the self-addressed Standardization Document Improvement Proposal (DD Form 1426) appearing at the end of this document or by letter.

2.2.2 Other Government documents, drawings, and publications. The following other Government documents, drawings, and publications form a part of this document to the extent specified herein. Unless otherwise specified, the issues are those cited in the solicitation.

D-11712 - Spool-Towline Shipping (Department of the Navy, Naval Air Development Center (NADC)).

(Copies of this drawing required by suppliers in connection with specified procurement functions should be obtained from the procuring activity or as directed by the contracting officer.)

2.3 Non Government publications. The following document(s) form a part of this document to the extent specified herein. Unless otherwise specified, the issues of the documents which are DoD adopted are those listed in the issue of the DoDISS cited in the solicitation. Unless otherwise specified, the issues of documents not listed in the DoDISS are the issues of the documents cited in the solicitation (see 6.2).

American National Standards Institute

ANSI/ASQC Z1.4 - Sampling Procedures and Tables for Inspection by Attributes.

(Application for copies should be addressed to the American National Standards Institute, Inc., 11 West 42nd Street, New York, NY 10036.)

American Society for Testing and Materials

ASTM E8 - Test Methods for Tension Testing of Metallic Materials

(Application for copies should be addressed to the American Society for Testing and Materials, 1916 Race St., Philadelphia, PA 19103.)

2.4 Order of precedence. In the event of a conflict between the text of this document and the references cited herein, the text of this document takes precedence. Nothing in this document, however, supersedes applicable laws and regulations unless a specific exemption has been obtained.

3. REQUIREMENTS

3.1 First Article. When specified (see 6.2), a sample shall be subjected to first article inspection in accordance with 4.3.

3.2 Components. The cable shall consist of one 19-wire strand having an armored covering of one flat wire.

3.3 Materials.

3.3.1 Steel. Steel used in the manufacture of the cable shall be carbon steel and shall be capable of meeting the requirements of this specification.

3.4 Design and construction.

3.4.1 Round wire (see 6.3.2). The round wire used in the fabrication of the strand shall be cylindrical, smooth, and of uniform high quality. It shall be free from splits, cold shuts, and other defects.

MIL-DTL-5765G

3.4.2 Flat wire (see 6.3.2). The flat wire used in the fabrication of the armor shall be smooth and of uniform high quality. The physical properties shall be as specified in Table I. It shall be free from splits, cold shuts, and other defects.

TABLE I. Physical Properties for Flat Wire

Cable Dia (In.)	Width (In.)	Thickness (In.)	Tensile Strength(PSI) Before Swaging	Weight of Zinc Coating (oz/sq.ft.)
1/8	.125 ±.005	.016 ±.001	147,000 ±17,500	.005 min
11/64	.125 ±.005	.024 ±.001	147,000 ±17,500	.005 min

3.4.3 Strand construction. The strand shall be a Warrington design conforming to Figure 1 and having 19 individual wires. Six wires shall be laid around a central core wire with a left-hand lay (see 6.3.4), and 12 wires shall be laid around the first operation in a left-hand lay. The wires shall have a pitch (see 6.3.5) of not more than 8 nor less than 7 times the strand diameter. The individual wires of the strand shall have three different diameter sizes. The strand diameter is shown on Figure 1.

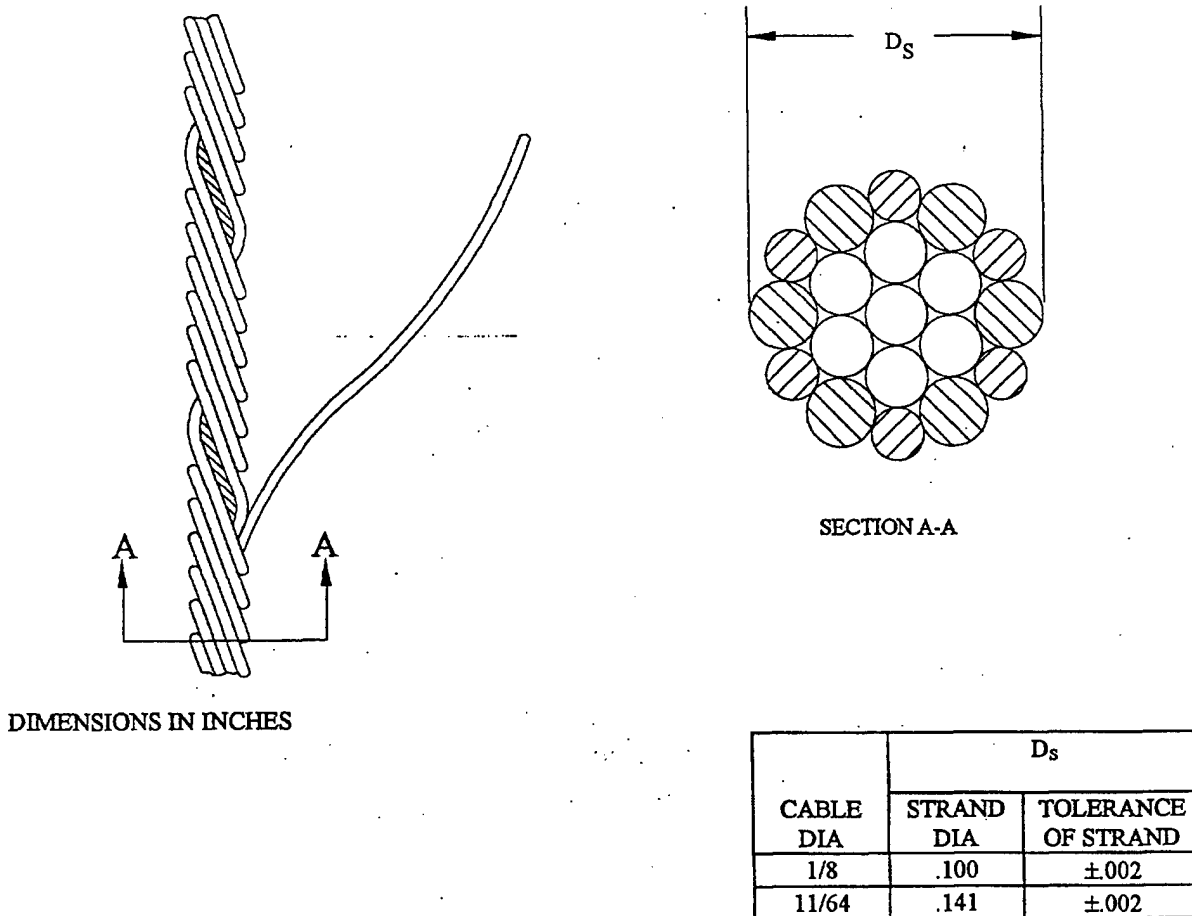

FIGURE 1. Strand Construction

MIL-DTL-5765G

3.4.4 Wire joints (flat or round wires). All wire joints in the cable shall be welded or brazed. Twisted or tucked-in joints shall not be accepted. Joints in individual wires in any layer of the strand shall be at least 20 feet apart.

3.4.5 Lubricant. The strand shall be coated with a friction preventative non-corrosive lubricant. The lubricant shall be applied so that each wire is coated. The lubricant shall also be resistant to oxidation.

3.4.6 Armoring. The armor shall consist of one flat steel wire wrapped spirally around the strand in a clockwise direction as shown on Figure 2. The spacing between the spirally wound armor flat wire shall be such as to provide a spacing after swage as required in 3.4.7.

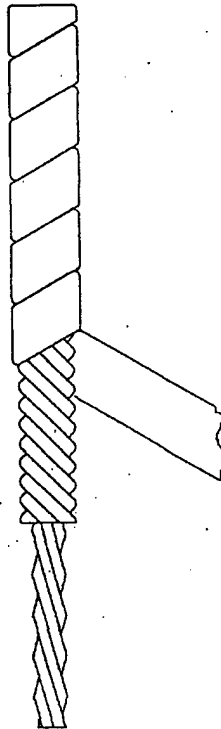

FIGURE 2. Cable Exploded

MIL-DTL-5765G

3.4.7 Swaging. After the armoring has been completed, the cable shall be rotary swaged. The resulting swaged cable shall be cylindrical, smooth, and free from surface metal folds. The swaging shall remove the internal stresses induced by wrapping, and the strand shall be free from tendencies to take a set when operating over level-winding and reeling equipment. The armor shall not unwind nor loosen from the strand when the cable is cut. The internal surface of the armor shall be cold-flowed into the interstices of the strand to lock the armor and prevent untwisting. The width of the flat wire after swaging shall be $.135 \pm .010$ inch for 1/8-inch cable and $.140 \pm .015$ inch for 11/64-inch cable. The spacing between the spirally wound armor after swaging shall be neither greater than $.037$ inch nor less than $.012$ inch for 1/8 inch cable, and neither greater than $.055$ inch nor less than $.035$ inch for 11/64 inch cable. Finished cable spacing shall be 90 percent compliant with no more than 7 consecutive wraps metal to metal.

3.5 Performance.

3.5.1 Wire Torsion Capacity. An 8 inch length of round wire used in the manufacture of the strand shall withstand a minimum number of turns, determined as 1.5 divided by the diameter of the wire, in inches, as tested in accordance with the wire torsion test of 4.5.3.

3.5.2 Twist characteristics. The cable shall have a maximum twist of one turn per foot of cable with a suspended load of 500 pounds, as tested by the cable torsion stability test of 4.5.4.

3.5.3 Breaking strength after endurance test. The breaking strength of the cable after being subjected to the endurance test shall meet the requirements of Table II and 4.5.6 as tested in 4.5.5.

3.5.4 Tensile strength (strand and cable). The tensile strength of new and unused cable as tested in 4.5.5 shall be not less than 2,160 pounds for 1/8-inch diameter and 4,000 pounds for 11/64-inch diameter.

3.5.5 Resistance to Unlaying. The wire of the strand shall resist unlaying when manually unlaidd and then replaced in the strand as tested in accordance with 4.5.2.

3.5.6 Resistance to Fraying. The unseized end of a cut strand shall not unwind or fray by more than the tolerance specified on figure 1, when tested in accordance with 4.5.2.

3.6 Dimensions.

3.6.1 Cable diameter (see 6.3.6). The diameter of the cable after application of the armor shall be $.1275 \pm .0025$ inch for 1/8-inch cable and $.1790 \pm .0030$ inch for 11/64-inch cable.

3.6.2 Length. The cable length shall be as specified by the procuring activity and shall be within ± 200 feet of the specified length. The cable shall be in one continuous length (see 6.2).

3.7 Weight. The weight of the completed cable per 100 feet shall be $4.025 \pm .075$ pounds for 1/8-inch diameter cable and $7.570 \pm .150$ pounds for 11/64-inch diameter cable.

3.8 Identification of product. Equipment, assemblies, and parts shall be marked for identification in accordance with MIL-STD-130.

3.8.1 Additional marking. Each spool shall be marked with the applicable lot number.

MIL-DTL-5765G

3.9 Workmanship. The cable shall be fabricated and finished in a workmanlike manner. Particular attention shall be given to accuracy of dimensions, twist, swaging, etc., as set forth in this specification and to freedom from blemishes, defects, burrs, sharp edges, loose wires, and kinks.

3.9.1 Cleaning. The cable shall be wiped clean with a cloth. Metal chips and other foreign material shall be removed during and after final assembly.

3.10 Spools. The cable shall be wound on shipping spools conforming to the dimensions on NADC drawing D-11712. The cable shall be level wound on the spool under a continuous tension of 25 lbs during the winding operation. When winding is complete, the end of the cable shall be securely fastened to the flange of the spool by means of a U-bolt or J-bolt to prevent slipping and loosening of the spool. Only one size cable shall be wound on a spool.

4. VERIFICATION

4.1 Classification of inspections. The inspection requirements specified herein are classified as follows:

- a. First article inspection (see 4.3)
- b. Quality conformance inspection (see 4.4)

4.2 Inspection conditions. Unless otherwise specified all inspections and tests shall be performed in accordance with the test conditions specified in ASTM E8.

4.3 First article inspection. First article inspection shall be performed on samples representative of the production of the item after the award of contract to determine that the production meets the requirements of this specification. First article inspection shall consist of all the tests described under 4.5 and shall be performed on the test sample specified in 4.3.1.

4.3.1 First article test sample. The first article test sample shall consist of not less than 200 feet of cable, after the removal of any necessary discard, taken from the head end of the first lot of cable manufactured.

4.3.2 Test report and test samples for the procuring activity. When specified, after completion of the first article tests, samples shall be accompanied by a test report prepared in accordance with MIL-STD-831.

4.4 Quality conformance inspection. The quality conformance inspection shall consist of:

- a. Individual inspections (see 4.4.2)
- b. Sampling inspections (see 4.4.3)

4.4.1 Lot. All the cable of the same construction, diameter, and heat produced continuously by one machine or one series of progressive processing machines and offered for delivery at one time shall be considered a lot for the purpose of examination and test. The maximum lot size shall be limited to 600,000 feet. A lot number shall be assigned by the manufacturer.

4.4.2 Individual inspection. The cable of each lot shall be subjected to the examination of product (see 4.5.1).

MIL-DTL-5765G

4.4.3 Sampling inspection. Samples (see 4.4.3.1) from each lot presented for acceptance shall be subjected to the tests under 4.5.2 and 4.5.3. Additional tests under 4.5.4, 4.5.5, 4.5.6, and 4.5.7 will not normally be required for subsequent lots of a particular part number, provided that the results of these tests for that part number were previously approved and available. When any of the manufacturing processes have changed that can affect the end item, the part numbers affected must be recertified under those additional tests and recorded. The procuring activity has the option of requiring a specific lot or part number to be tested under the above additional tests based on the history of the item.

4.4.3.1 Samples. Statistical sampling and inspection shall be in accordance with the general requirements of ANSI/ASQC Z1.4. Unless otherwise specified, these samples shall consist of not less than 30 feet of cable. Lot acceptance criteria shall be based on a single sampling plan with a zero acceptance number.

4.5 Test methods.

4.5.1 Examination of product. The cable shall be examined carefully for workmanship and finish as it is wound on the shipping spool. The cable shall be stopped when closer inspection is deemed necessary. Prior to winding, any unqualified portion from the lead end of the cable shall be discarded.

4.5.2 Unlaying and fraying tests. These tests shall be conducted prior to any other tests specified herein. The armor shall be removed from a 12-inch length of cable, and the strand shall be subjected to the tests specified in 4.5.2.1 and 4.5.2.2. Failure of the sample to pass these tests shall be cause for rejection of the cable lot represented.

4.5.2.1 Unlaying test. A minimum of two wires shall be unlayed from the strand as shown on Figure 1 for a distance of not less than 8 inches and then returned to the original helical position in the strand. Wires so unlayed and replaced by hand shall assume original positions in the finished strand without undue stresses which would tend to unwind or distort the helical shape.

4.5.2.2 Fraying test. After the unlaying test specified in 4.5.2.1 has been satisfactorily completed, the strand shall be cut in two pieces. There shall be no unwinding or fraying.

4.5.3 Wire torsion test. A minimum of two wires taken from the strand before the armor is applied shall be subjected to this test. Failure of one wire to withstand the turns specified shall not constitute the final cause for rejection. In such cases, an additional two wires from the same sample shall be tested. If either wire of the second two wires fails the test, the strand shall be rejected.

4.5.3.1 Torsion test method. The wire shall be gripped by two clamps 8 inches apart. One clamp shall be free to revolve and move in an axial direction. The free clamp shall revolve in one direction at a uniform speed of 60 revolutions per minute or less and without heating the wire perceptibly. Sufficient tension shall be applied longitudinally to the wire to keep it from kinking during the test. The number of complete turns causing failure shall be not less than the number computed by the following formula:

The number of turns in an 8-inch length = $1.5 / \text{diameter in inches}$

MIL-DTL-5765G

4.5.4 Cable torsion stability test (twist characteristic). The resistance of a cable to unlaying under load is termed its torsion stability. In determining this property, a minimum of two lengths of cable of each size, each 6 feet or longer, shall be prepared by the addition of end terminals. One end of the cable assembly shall be connected to a firm overhead fixture and the cable allowed to dangle until it is completely relaxed. A 500-pound weight shall be attached to the opposite end of the cable. When the 500-pound load is applied to the cable, the weight shall be allowed to rotate. Rotation of the weight due to the untwist of the cable shall be retarded by stopping the weight's rotation at least once each revolution to prevent overrunning. The number of revolutions shall be counted. When the weight becomes completely at rest for 10 seconds, the revolutions shall be recorded. With the cable under load and the weight free to turn, there shall be no visible loosening, distortion, or cracking of the armor. The maximum number of revolutions acceptable shall be no more than one revolution per foot of cable between terminals.

4.5.5 Tension test (breaking strength). Tension testing insures that the cable meets the required strength when new, or after the endurance test, as specified. Three lengths of each size cable shall be tested. Each tension test length shall be not less than 24 inches long. The tension test shall be conducted in accordance with ASTM E8. With the sample in place and ready for testing, the distance between the jaws of the tension testing machine shall be not less than 10 inches. Samples may be clamped in the jaws by swaged fittings on both ends of each sample or by any suitable means.

4.5.6 Endurance test. Three lengths, each 13 feet long, shall be taken from each sample of cable for testing. The application of lubricant other than, or in addition to that used to impregnate the cable during the process of manufacture shall not be permitted either before or during the endurance test. The total number of reversals for each sample shall be as shown in Table II. The test setup shall be as shown on Figure 3 employing test pulleys conforming to the dimensions specified on Figure 4. The total travel of the cable in one direction shall be 13-1/2 inches. No cracks shall be visible in the armor at the conclusion of the 20,000 or 10,000 reversals. Sample No. 2 and sample No. 3 shall be tested as specified in 4.5.7.

TABLE II. Endurance-Strength Relationship for Target Tow Cable

Cable Size	Sample #	Number of Reversals	Minimum Break Strength After Endurance Test (lbs)
1/8 - inch	1	20,000	2,000
	2	40,000	1,300
	3	48,000	700
11/64	1	10,000	3,333
	2	16,000	1,750
	3	22,000	500

4.5.7 Tensile strength after endurance test. Each sample that has satisfactorily passed the endurance test specified in 4.5.6 shall be subjected to the tension test specified in 4.5.5 to determine the breaking point of a portion of the cable that has been subjected to reverse bending by contact with a test pulley on a machine or test stand. The tensile strength of the sample shall be not less than that shown in Table II.

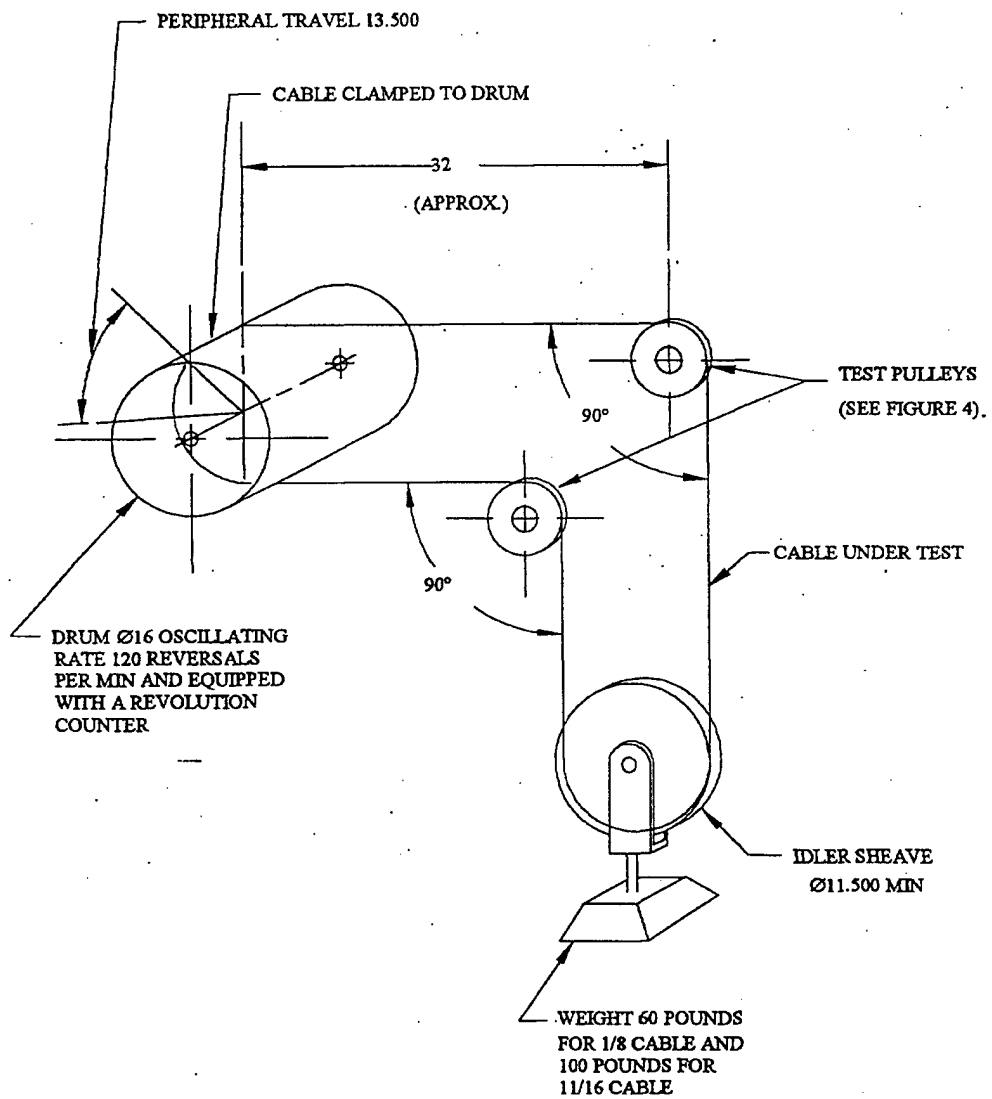

DIMENSIONS IN INCHES

FIGURE 3. Cable-Endurance Testing machine (diagrammatic)

MIL-DTL-5765G

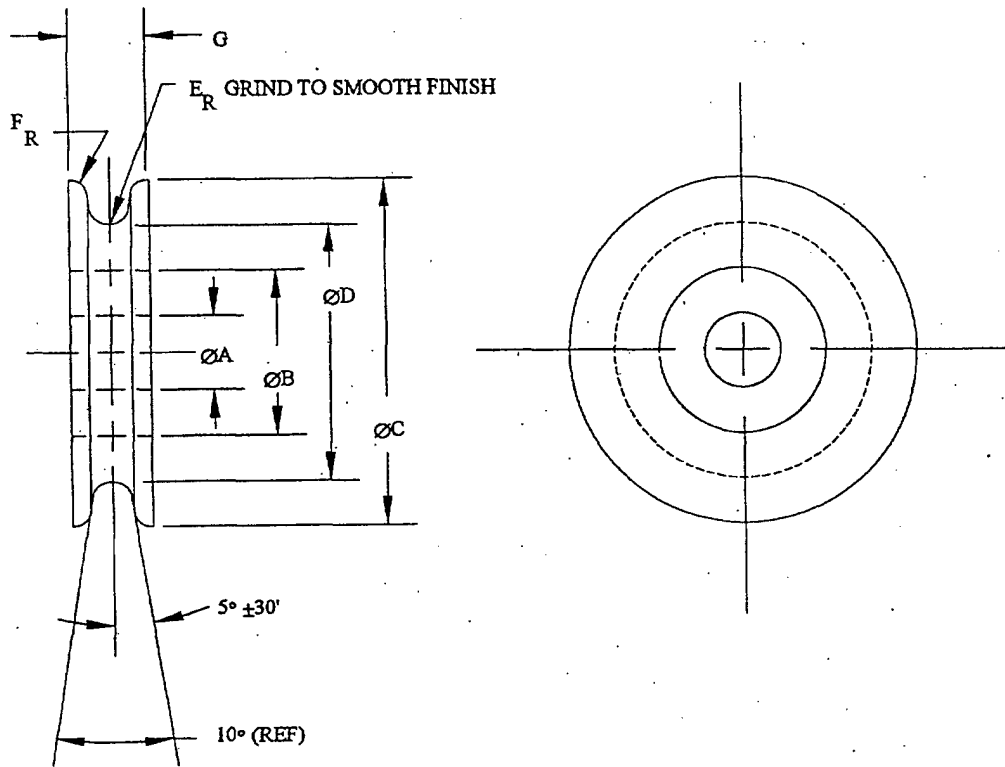

NOTE: Fit pulleys with suitable ball or roller bearings.
 "Ø B" should be bored and ground to light press fit for bearings
 "Ø A" bore of bearing as received.

Material: Tool Steel.
 Heat Treat: Harden to HRC 60 minimum.

DIMENSIONS:

- "ØC" = 4.2500 ± 0.0156
- "ØD" = $3.500 + .005 - .000$
- "E_R" = $.133 + .002 - .000$
- "F_R" = $.100 \pm .003$
- "G" = $.5000 \pm .0156$

FIGURE 4. Test Pulley

5. PACKAGING

5.1 Packaging. For acquisition purposes, the packaging requirements shall be as specified in the contract or order (see 6.2). When actual packaging of material is to be performed by DoD personnel, these personnel need to contact the responsible packaging activity to ascertain requisite packaging requirements. Packaging requirements are maintained by the Inventory Control Point's packaging activity within the Military Department or Defense Agency, or within the Military Department's System Command. Packaging data retrieval is available from the managing Military Department's or Defense Agency's automated packaging files, CD-ROM products, or by contacting the responsible packaging activity.

6. NOTES

(This section contains information of a general or explanatory nature which may be helpful, but is not mandatory)

6.1 Intended use. The cable covered by this specification is intended for use in towing aerial targets by aircraft. The lengths of cable procured and size specified will vary to meet the needs of a variety of aircraft reeling machines used in conjunction with numerous target types.

6.2 Acquisition requirements. Acquisition documents should specify the following:

- (a) Title, number, and date of this specification.
- (b) Issue of DoDISS to be cited in the solicitation, and if required, the specific issue of individual documents referenced.
- (c) Size of cable required (see 1.2).
- (d) Length of cable required (see 3.6.2).
- (e) When First Article Inspection must be performed.
- (f) Packaging requirements.

6.3 Definitions. For the purposes of this specification, the following definitions apply.

6.3.1 Cable. A cable is a group of round wires helically twisted or laid about a center round wire and having an armor of one flat wire applied as specified herein.

6.3.2 Wire. A wire is an individual piece of slender, flexible metal, either round or flat.

6.3.3 Strand. A strand is a group of round wires helically twisted or laid about a center round wire and having no armor.

6.3.4 Lay (or twist). The helical form taken by the wires in the cable will be the lay or twist in the cable. In a right-hand lay, the wires are in the same direction (clockwise) as the thread on a right-hand screw and for a left-hand lay, the wires are in the opposite direction (counterclockwise).

6.3.5 Pitch (or length of lay). The distance parallel to the axis of the cable in which a wire makes one complete turn about the axis will be the pitch or length of lay of the cable.

MIL-DTL-5765G

6.3.6 Cable diameter. When measured at the cross section, the diameter will be the straight line passing through the center and terminating on the outermost edge of the cable (including the armored covering).

6.4 Changes from previous issue. Marginal notations are not used in this revision to identify changes with respect to the previous issue due to the extent of the changes.

6.5 Color tracer filament. Each manufacturer shall incorporate color tracer filaments into the cable for the purposes of identification. The accepted color codes for known manufacturers is hereby listed; any manufacturer not listed in the specification may obtain a combination from the preparing activity.

<u>Manufacturer</u>	<u>Color Code</u>
Bergen Cable Technologies	Orange and Green
Loos and Co., Inc.	Red and Yellow

6.6 Part Identification Number (PIN). The PIN to be used for Target Tow Cable acquired to this specification are created as follows:

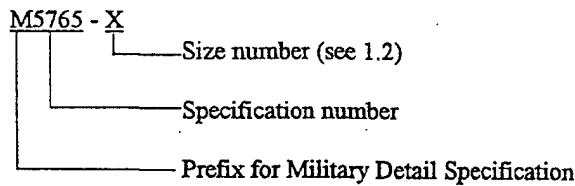

6.7 Subject term (keyword) listing.

Cable, target tow

Custodians:
Navy - AS
Air Force - 99

Preparing activity:
DLA-IS

(Project 4010-0208)

STANDARDIZATION DOCUMENT IMPROVEMENT PROPOSAL

INSTRUCTIONS

1. The preparing activity must complete blocks 1, 2, 3 and 8. In block 1, both the document number and revision letter should be given.
 2. The submitter of this form must complete blocks 4, 5, 6 and 7.
 3. The preparing activity must provide a reply within 30 days from receipt of the form.
- NOTE: This form may not be used to request copies of documents, or to request waivers, or clarification of requirements on current contracts. Comments submitted on this form do not constitute or imply authorization to waive any portion of the referenced document(s) or to amend contractual

RECOMMEND A CHANGE:	1. DOCUMENT NUMBER MIL-DTL-5765G	2. DOCUMENT DATE (YYMMDD) 960105
----------------------------	---	---

3. DOCUMENT TITLE: **STRAND, WIRE, ARMORED STEEL**

4. NATURE OF CHANGE (Identify paragraph number and include proposed rewrite, if possible. Attach sheets if needed.)

5. REASON FOR RECOMMENDATION

6. SUBMITTER

a. NAME (Last/First/Middle/Initial)	b. ORGANIZATION	
c. ADDRESS (Include Zip Code)	d. TELEPHONE (Include Area Code) (1) Commercial (2) AUTOVON (if applicable)	e. DATE SUBMITTED (YYMMDD)

8. PREPARING ACTIVITY DLA-IS

a. NAME Emelia Altomari	b. TELEPHONE (Include Area Code) (1) Commercial (215) 697-6827
c. ADDRESS (Include Zip Code) Defense Industrial Supply Center 700 Robbins Avenue Bldg. 3 (Code DISC-EED) Philadelphia, PA 19111-5096	IF YOU DO NOT RECEIVE A REPLY WITHIN 45 DAYS, CONTACT: Defense Quality and Standardization Office 5203 Leesburg Pike, Suite 1403 Falls Church, VA 22041 TELEPHONE (703) 756-2340 AUTOVON 289-2340

APPENDIX B

STEADY-ANALYSIS OF THE TOW CABLE CONFIGURATION

If the towing aircraft executes a steady level turn, the tow cable will, after initial transient motions damp out, will assume a certain equilibrium shape in which the tensile, centrifugal, aerodynamic, and gravitational forces balance out. Straight and level flight may be regarded as a special case in which the radius of turn is very large. Because the centrifugal force will cause the banner to follow a curve of greater radius than that of the aircraft, the radius at a point on the cable distance S from the banner varies with S . Since the configuration is a steady-state one the airspeed at any point on the cable is also varies directly as the radius. The relationship is shown in figure A1.

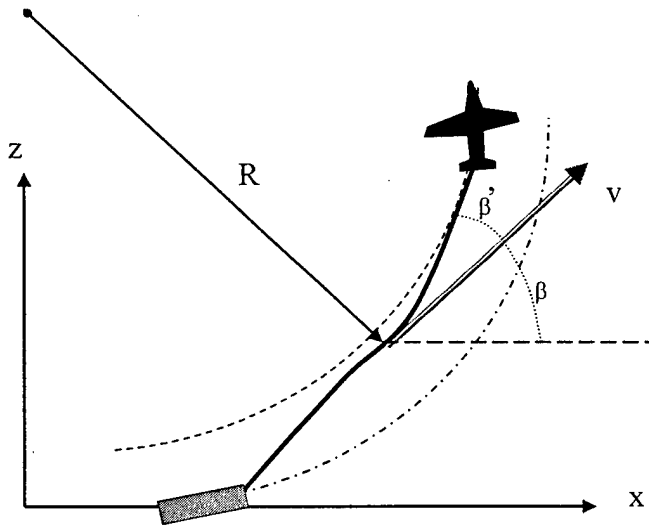
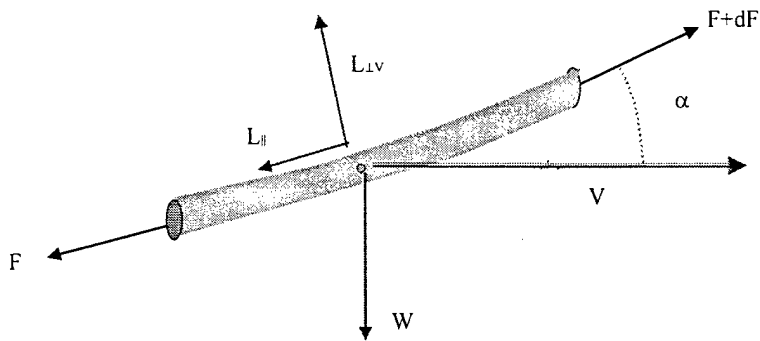

Figure A1. Aircraft and banner paths for a steady turn.

Hence the centripetal acceleration and the dynamic pressure are also variables along the cable. All the variables will be found as functions of S .

$$v = \dot{\theta}_0 R(S) \quad a = \dot{\theta}_0 v \quad q = \frac{1}{2} \rho_\infty v^2$$

The aerodynamic forces on an element dS of the cable arise from cross-flow due to its angle of attack and from friction due to flow along the cable. Because the small diameter of the cable places it in the subcritical Reynolds number regime, the forces can be obtained from the cross-flow principle [Hoerner, Fluid-Dynamic Drag, Sighard F. Hoerner 1965, Great Britain, 3-11]. Define the angles in the vertical plane as in figure A2 and in the horizontal plane as in A3.



Force balance in the vertical plane for a cable element dS.

Figure A2. Angles and forces in the vertical plane.

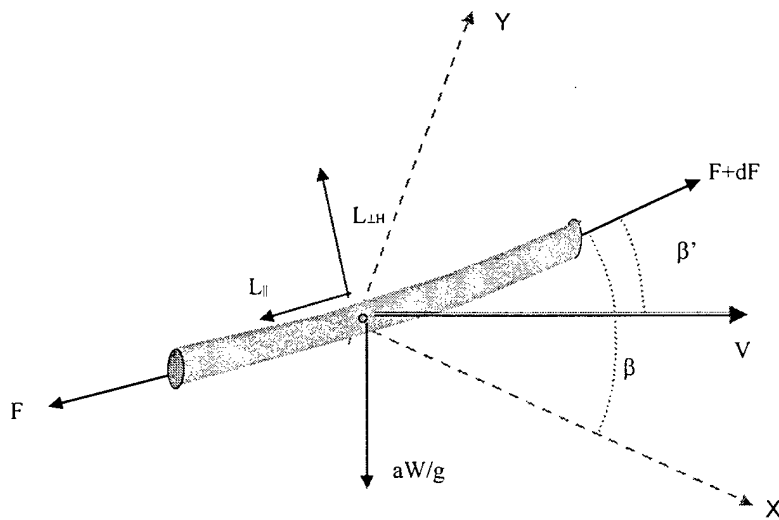

Force balance in the horizontal plane for a cable element dS.

Figure A3. Angles and forces in the horizontal plane.

The force perpendicular to the a cable element, due to cross flow, is given by,

$$L_{\perp} = qdC_D(\sin^2 \alpha + \sin^2 \beta') + q\pi dC_F \sin \beta'$$

where the last term is the component of the friction force. The friction force is opposite the velocity and so it has a component normal to the cable element. Note that the angle of attack of the cable element in the horizontal plane is β' , while β is the angle of the velocity with respect to the fixed (x,z) coordinate system. The force along the cable comes entirely from the friction term.

$$L_{\parallel} = q \pi d C_F \cos \beta'$$

The aero-force normal to the cable element L_{\perp} has both horizontal and vertical components. It makes an angle ϕ with respect to the horizontal.

$$\tan \phi = \frac{\sin \alpha}{\sin \beta'}$$

The differential equations that determine the cable shape are:

The increase in tension, F, to balance the aero-drag and the components of centrifugal force and gravity which act along the cable.

$$\frac{dF}{dS} = L_{\parallel} + \frac{a}{g} W \sin \beta' + W \sin \alpha$$

The curvature in the horizontal plane due to the forces normal to the cable element in that plane.

$$\frac{d\beta}{dS} = \frac{1}{F} \left(L_{\perp} \cos \phi + \frac{a}{g} W \cos \beta' \right)$$

The curvature in the horizontal plane due to the forces normal to the cable element in that plane. This is also the change in the angle of attack in the vertical plane since it is assumed that the motion is entirely in the horizontal plane.

$$\frac{d\alpha}{dS} = \frac{1}{F} \left(L_{\perp} \sin \phi + \frac{a}{g} W \cos \alpha \right)$$

The change in angle of attack in the horizontal plane

$$\frac{d\beta'}{dS} = \frac{d\beta}{dS} - \frac{1}{R}$$

For convenience in graphing and interpreting the results the (x,y,z) coordinates of each cable element are also calculated.

$$\frac{dx}{dS} = \cos \beta \quad \frac{dy}{dS} = \sin \alpha \quad \frac{dz}{dS} = \sin \beta$$

The change in radius, R, is given by.

$$\frac{dR}{dS} = -\sin \beta'$$

And for convenience the corresponding angle coordinate is also calculated.

$$\frac{d\theta}{dS} = \frac{1}{R} \cos \beta'$$

These differential equations were integrated using a 4th order Runge-Kutta scheme. The code in Common Lisp is attached below.

The integration starts from the banner and finds the shape forward to where the aircraft must be in order for the banner to follow the given radius at the given speed. However, what are needed are solutions for given aircraft speed and angle-of-bank. To find such solutions it was necessary to iteratively adjust the initial conditions of the banner speed and radius until the speed and radius at the aircraft end of the cable matched the desired conditions.

APPENDIX C.

**TOW CABLE / JET INTERFERENCE
C B A S SIMULATION ANALYSIS**

TOW CABLE / JET INTERFERENCE

C B A S SIMULATION ANALYSIS

Prepared By
U.S. ARMY AMCOM
SS&DD / Aerodynamics
AMSAM-RD-SS

20 September, 2000

Don Ferguson

Project Engineer

TOW CABLE/ JET INTERFERENCE ANALYSIS

A T2C towed banner was modeled in both the 3-D CBAS and the two dimensional CBAS-2D. The baseline data provided are shown in Figure 1. Data that was not provided was estimated. All of the known parameters were entered into Missile DATCOM to determine the static and dynamic derivatives and basic aero coefficients. These data were entered into both CBAS simulations in an attempt to match the data provided by Brent Meeker. Figure 2 shows that this could not be done without violating the physics of the simulation; and still use consistent aerodynamic coefficients. However, the simulation model is felt to be sufficient.

The only parameters that could validly be varied were: Tow -wire / tow attachment configuration, tow dimensions, cable normal and tangential coefficients, and tow drag coefficient. The only parameters that were ultimately changed to match the data provided were cable aero coefficients and tow drag coefficient. The former affected the droop considerably and was matched at 150 KEAS. The later affected the droop only slightly. When the same input data were applied at 120 and 200 KEAS, the match was not as good.

Using the CBAS input derived as above, a series of simulation plots was developed to determine the basic 3-dimensional motion of the towed banner. This was necessary to the understanding of the cable motion at the tow A/C. These plots are included in Attachment 1.

Code modifications were necessary to obtain cable motions in a file that could be manipulated to provide the desired movement of the cable at the aircraft attach point. This was done as follows:

1. A file was produced which included the motions of the cable segment ends in space and time. Where: X and Y described the plane of motion of the tow A/C. Z was directed down in a right-hand coordinate system.

2. The cable segment (rod) attached to the A/C was traced through time. Two consecutive time steps were used to calculate a unit vector defining the heading of the A/C.

3. The vectoral difference between the rod end at the A/C and the trailing end of the rod at the second time step was calculated and used to form a rod direction unit vector.

4. The vectoral difference between the two unit vectors provided the following:
Azimuth = ASIN (lateral component); and Elevation = ASIN (vertical component)

5. By time stepping through the aircraft maneuver, the history of the relative Azimuth and Elevation could be plotted. The A/C alpha and beta were always set at zero. CBAS was programmed to perform a 3-step maneuver series: a straight run, a 180 degree left turn, and a second straight run. The limited scope of the analysis precluded varying the ramp times as a parameter. Both 30 and 60 degree banked turns were run at 120, 150, and 200 KEAS. Attachment 2 contains the results of the analysis.

SUMMARY OF OBSERVATIONS

Attachment 1 contains plots of the motion of the towed banner. The X-Y plots show the banner to swing wide of the path of the tow A/C at all airspeeds and banked turn angles. The X-Z plots show the slackening of the cable when the tow A/C enters the turn and the overshoot of its altitude later in the turn. At higher speeds this overshoot disappears. These gyrations are reflected in the cable tension plots also included in this Attachment. The peak tensions of 300, 340, and 450 at airspeeds of 120, 150 and 200 KEAS are probably somewhat representative of the actual cable forces. The majority of the force comes from the cable drag which is not as roughly approximated as the banner drag.

Attachment 2 shows the Azimuth and Elevation plots as viewed looking aft from the aircraft down the attached cable. As the aircraft is in a left turn the Azimuth, to the viewer, is often first to the right, (-), and then to the left, (+). For the engine exhaust to get close to the cable, a coincidence of the Azimuth and Elevation must occur in a small corridor. In a 60 degree banked turn, the left engine drops down and inward with respect to the viewer looking down the cable. The right engine moves up and outward, perhaps making it always out of reach. The note on the plot is an approximation (based on estimated dimensions) of the movement of the lower edge of the left engine (Exhaust Point). Both AZ & EL plots and AZ vs EL plots are included.

Attachment 3 shows the results of a cursory investigation of the movement of the exhaust point with angle of attack and roll angle. These results are included in the Attachment 2 plots. The inset figure shows the range of AZ and EL with roll angle. As the A/C rotates around the roll axis, the exhaust point AZ moves rapidly across a vertical plane through the cable. Since this limited study only investigated Thetas of 30 and 60 deg, it is not thorough. Neither of these angles showed a critical condition to exist.

There may be other factors that were not considered in this analysis that are important. These include jet induced inflow, cant of the engine with respect to the line of flight, jet expansion, and temperature distribution in the wake.

Also due to the limited scope of this analysis, the cable definition was rather coarse. The first CBAS rod element was 138 ft long (at the A/C). Since the curvature of the cable is very small near the tow point, this simulation coarseness error should be rather small.

CONCLUSIONS

An analysis of the interference of the T2C engine with a banner tow cable was conducted. The original scope of the project was to determine the direction of the cable from the attach point at the tow A/C. This was completed successfully. During the course of the investigation (which only included banked turns of 30 and 60 deg) the influence of A/C angle of attack and roll angle were found to be extremely important to the interference. The angle of attack is a function of airspeed, A/C weight and normal acceleration. These move the Elevation angle over a wide range but the Azimuth is hardly affected. The roll angle moves the exhaust point over a wide range of Azimuth though a narrow range of elevation.

This limited study showed no conclusive evidence of engine exhaust interference with the cable. Thus a more thorough investigation will be required to find the conditions of coincidence of the cable and exhaust wake.

Another parameter in the cursory Alpha/Theta investigation which showed some influence on the motions of the tow cable at the A/C was the initial lateral motion of the tow point when the bank is initiated. Since the first motion of the tow point is to the right in a left turn, some unusual dynamics occur. However, transients such as this would probably not be important unless they caused the cable to be ingested into the jet wake. Thus the influence of the jet entrainment strength is a possible consideration.

It is recommended that the analysis be expanded to include a parametric study using bank angle, airspeed, and weight. Further, the A/C geometry must be better defined. The incidence of the jet exhaust with the fuselage, and jet wake qualities should be included. It is well known that there is a set of conditions which cause the tow cable to be cut by the jet wake. However these conditions are yet unknown.

ATTACHMENT 1

FIGURE 1: BASELINE TOW BANNER INFORMATION

Tow aircraft: T2C
 Cable Length: 800 ft
 Cable Dia: 11/64 in (0.172 in)
 Cable Type: Armored 19-strand wire
 Cable Weight: 0.0757 lb/ft

Cable Droop:	KEAS	Droop (ft)
	120	300
	150	200
	200	100

Normal Mission KEAS: 150 Kts
 Failure Geometry:

BRENT'S DROOP DATA

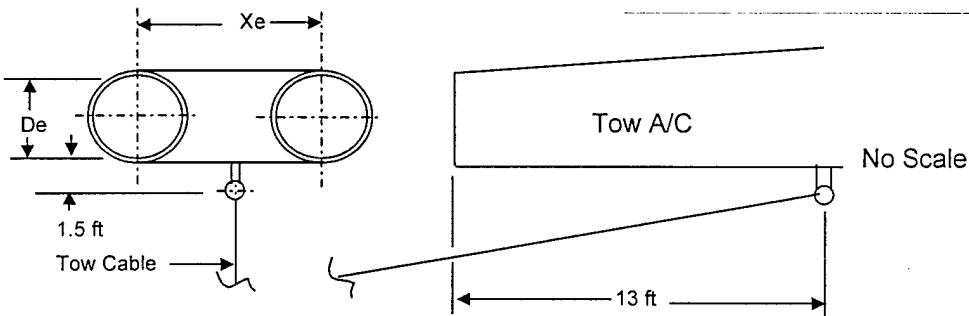
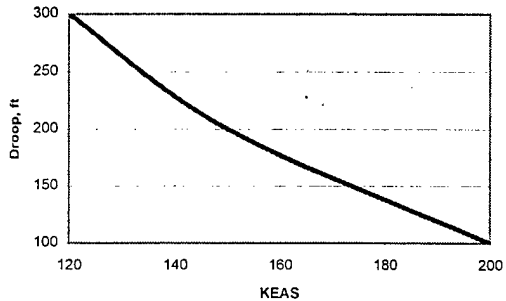

Bank Angles: 30 to 60 deg
 Ramp Times: 0.5, 1.0, and 1.5 sec

GENERAL INFORMATION:

MQM 2X12 Cloth Banner = MDI has a $C_{do} = 0.04$ based on $S = 27.16 \text{ ft}^2$
 This is an equivalent flat plate area of $0.04827 \cdot 16 = 1.09 \text{ ft}^2$ (Smaller Banner)
 From Hoerner, $C_d = 0.033$ based on flag area ($2 \cdot 4 \cdot 20 = 160 \text{ ft}^2$)
 This is an equivalent flat plate area of $0.033 \cdot 160 = 5.28 \text{ ft}^2$

Use 5.0 ft^2 as first guess

At 150 KEAS, $q = 76 \text{ psf}$ & Drag = 380 lbs.
 Weight = 87 lbs.

Radius of turns: $R = V^2 / (g \cdot \tan(\Phi))$

For $\Phi = 30 \text{ deg}$,	$R = 2211 \text{ ft}$	(at 120 KEAS, SL)
For $\Phi = 60 \text{ deg}$,	$R = 737 \text{ ft}$	(at 120 KEAS, SL)
For $\Phi = 30 \text{ deg}$,	$R = 3453 \text{ ft}$	(at 150 KEAS, SL)
For $\Phi = 60 \text{ deg}$,	$R = 1150 \text{ ft}$	(at 150 KEAS, SL)
For $\Phi = 30 \text{ deg}$,	$R = 6143 \text{ ft}$	(at 200 KEAS, SL)
For $\Phi = 60 \text{ deg}$,	$R = 2048 \text{ ft}$	(at 200 KEAS, SL)

FIGURE-2: DROOP DATA COMPARISON

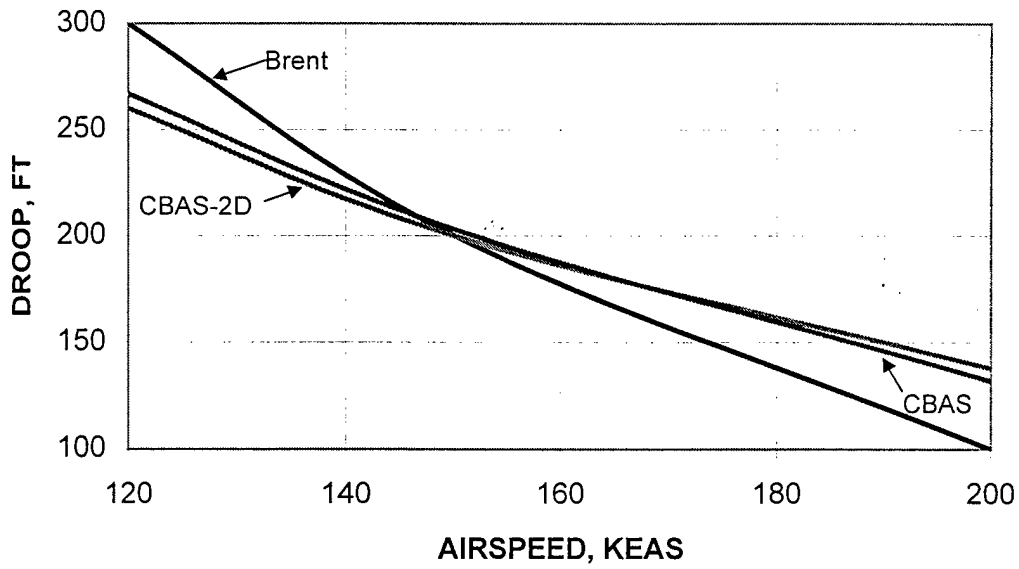

**A/C AND TOW GROUND TRACK
120 KEAS, 60 DEG BANKED TURN**

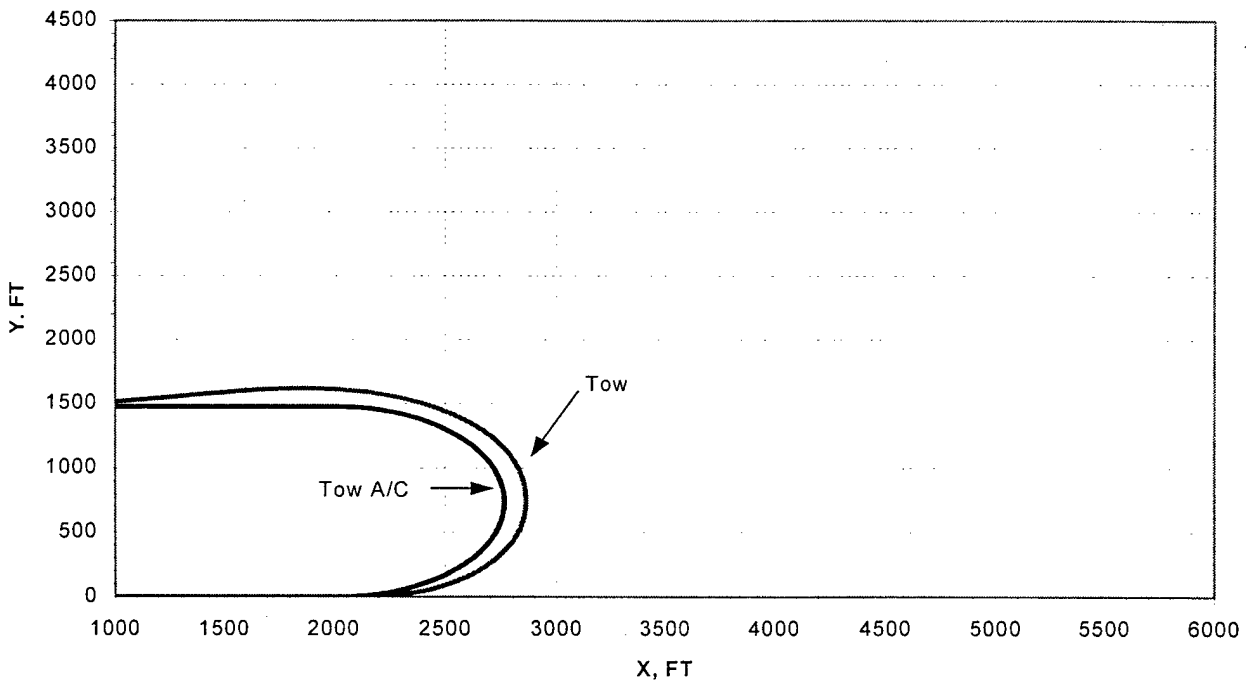

A/C AND TOW GROUND TRACK
150 KEAS, 60 DEG BANKED TURN

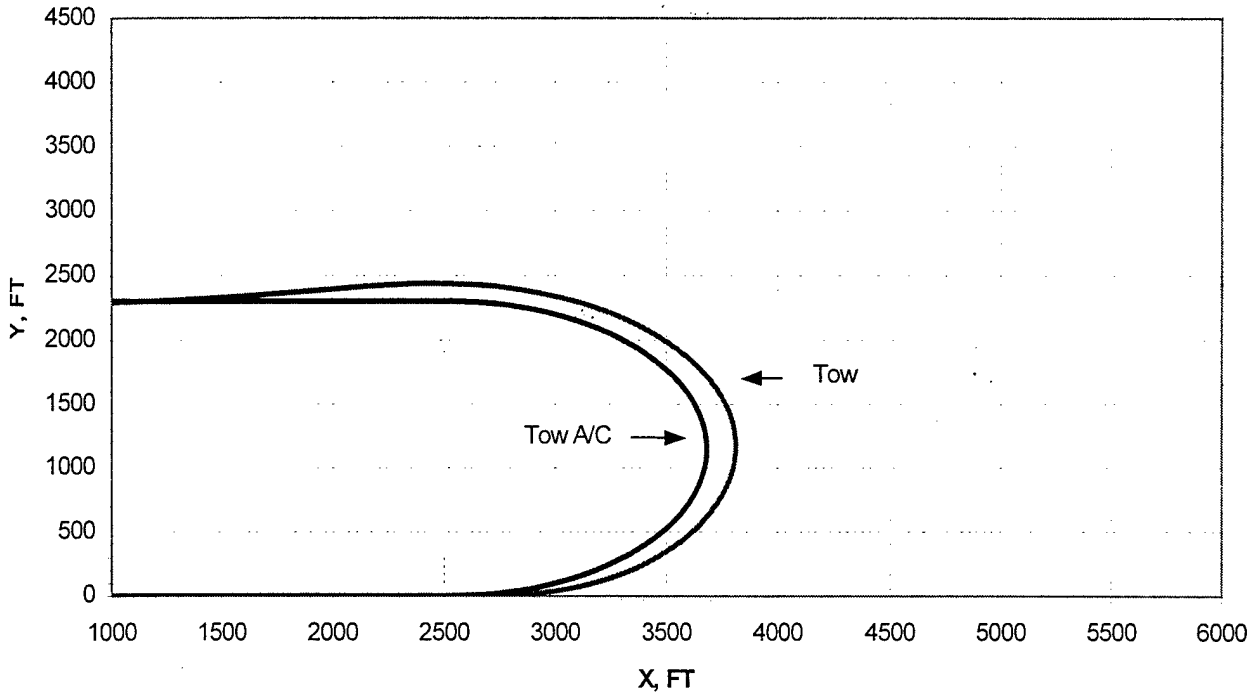

A/C AND TOW GROUND TRACK
200 KEAS, 60 DEG BANKED TURN

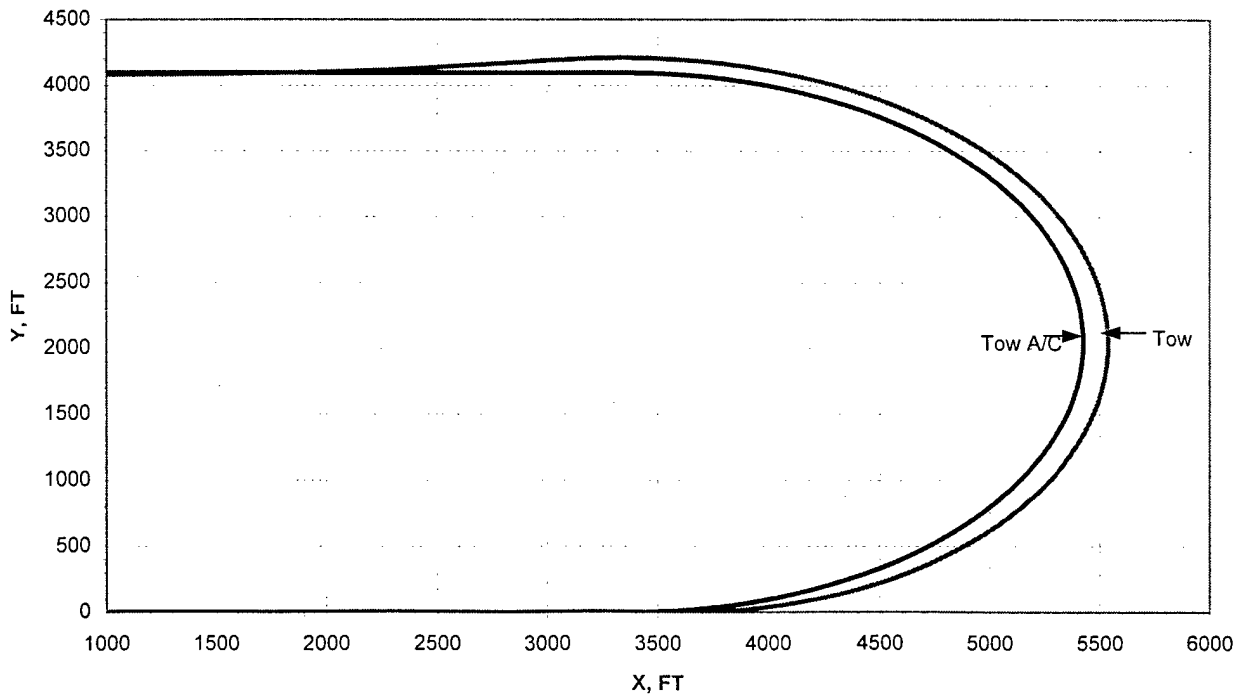

DELTA Z TOW IN TURN
120 KEAS, 60 DEG BANKED TURN

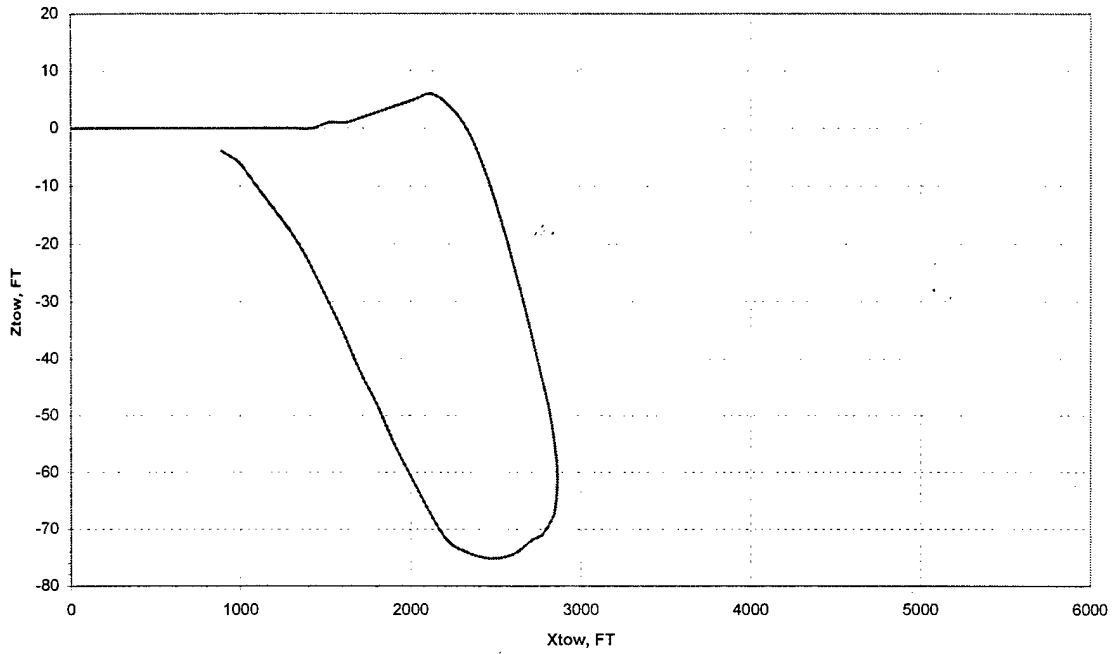

DELTA Z TOW IN TURN
150 KEAS, 60 DEG BANKED TURN

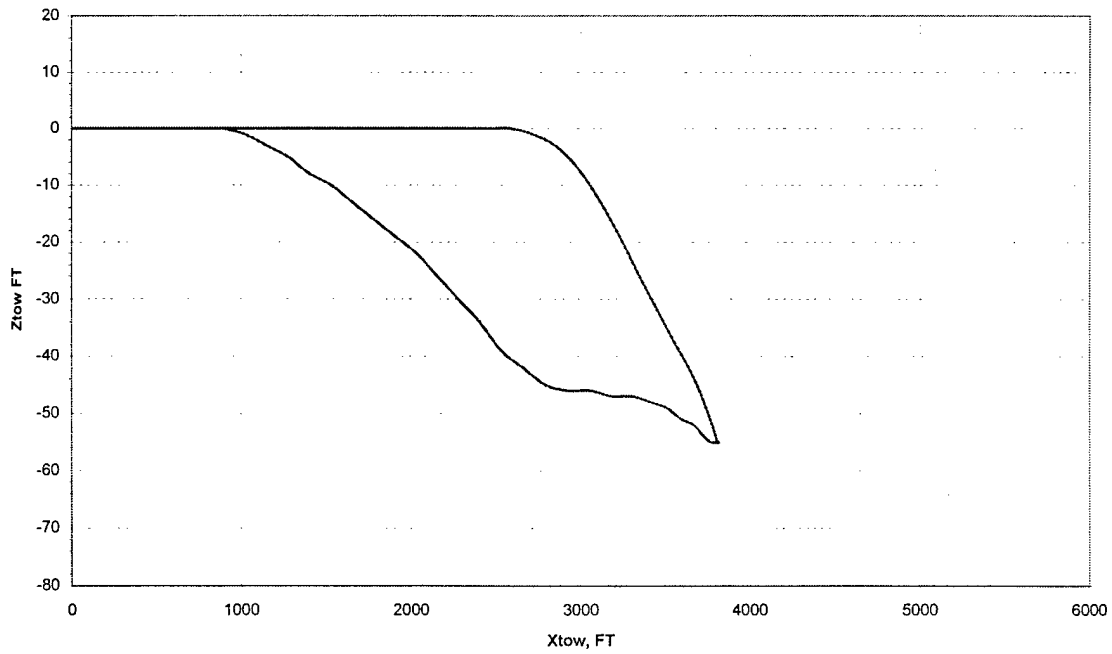

TOW DROOP IN TURN
200 KEAS, 60 DEG BANKED TURN

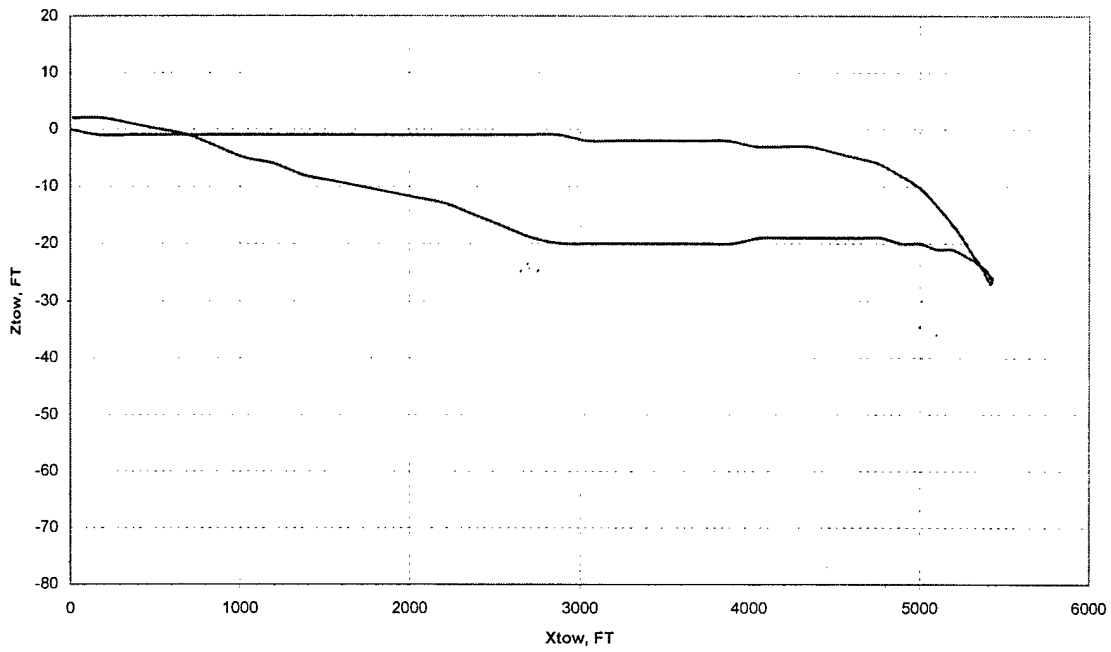

CABLE TENSION AT A/C IN TURN
120 KEAS, 60 DEG BANKED TURN

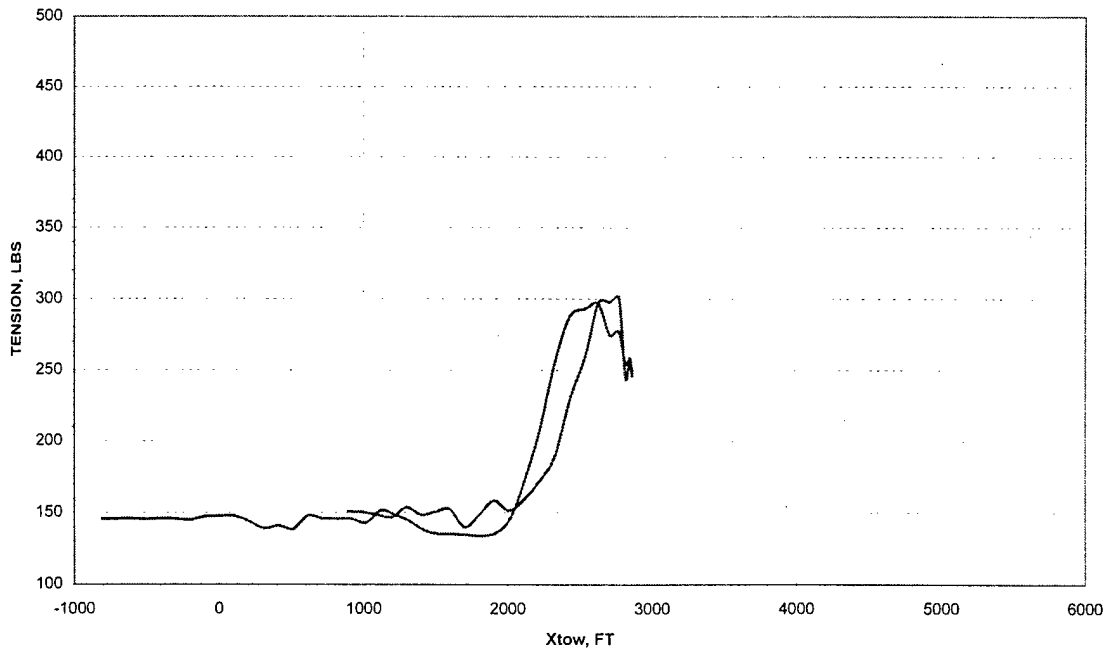

CABLE TENSION AT A/C IN TURN
150 KEAS, 60 DEG BANKED TURN

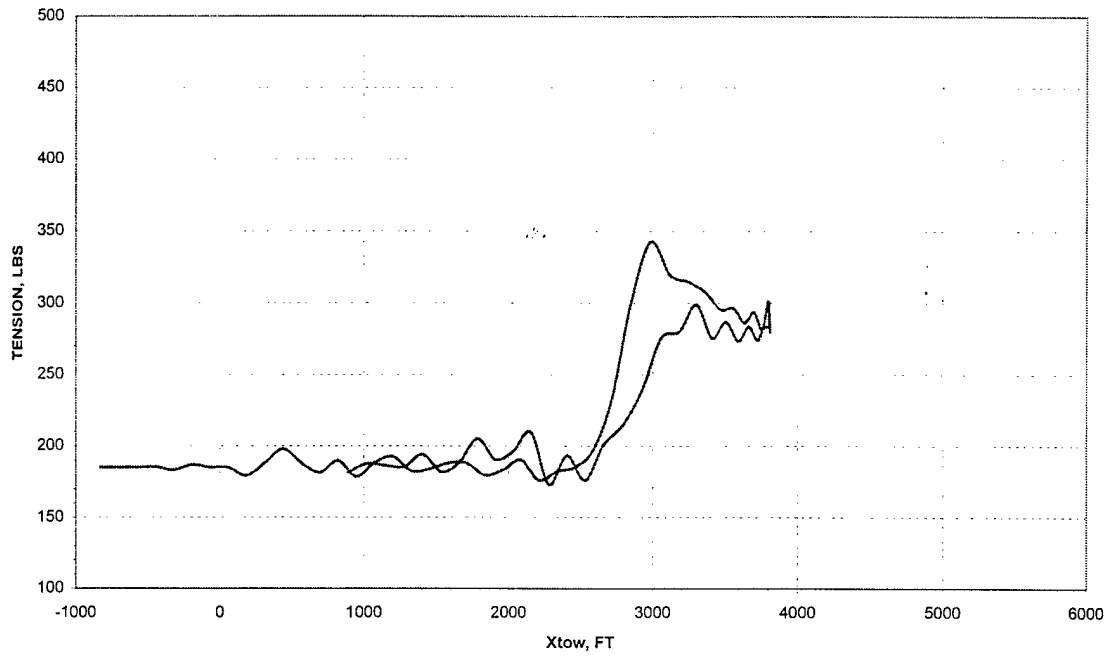

CABLE TENSION AT A/C IN TURN
200 KEAS, 60 DEG BANKED TURN

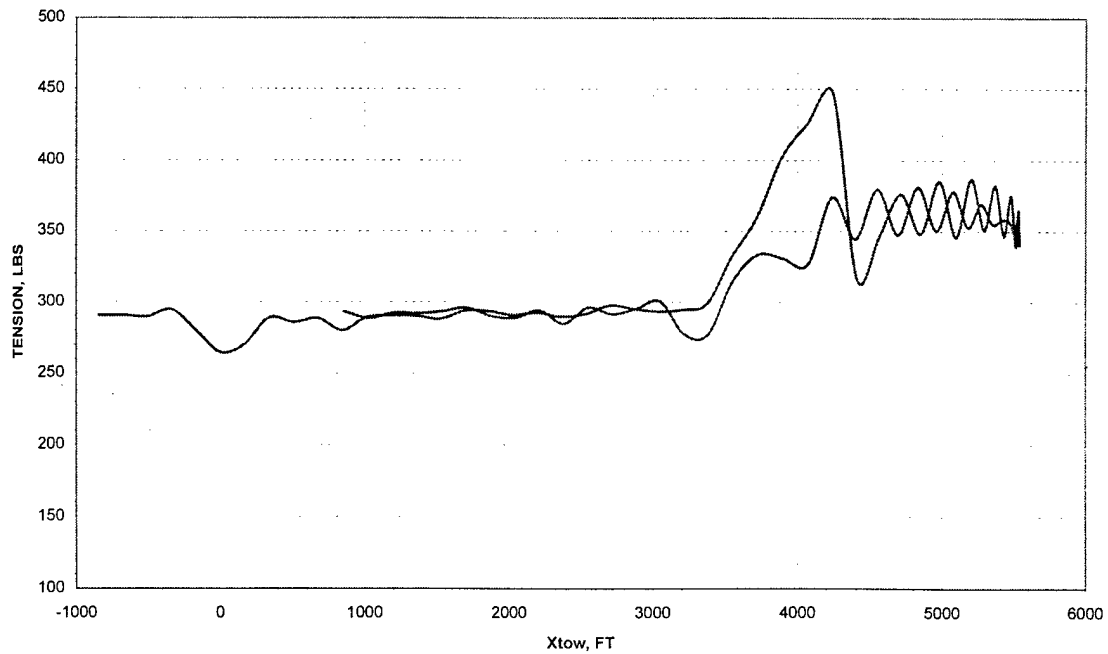

ATTACHMENT 2

TOW CABLE ANGLE FROM A/C
30 DEG BANKED TURN @ 120 KEAS

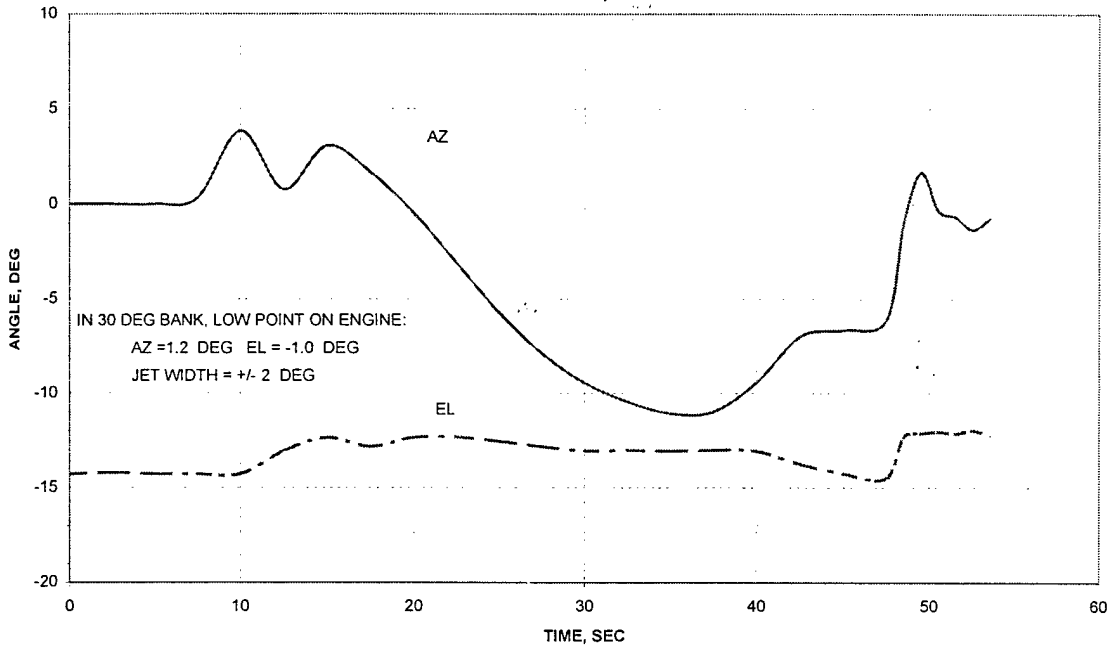

TOW CABLE ANGLE FROM A/C
30 DEG BANKED TURN @ 150 KEAS

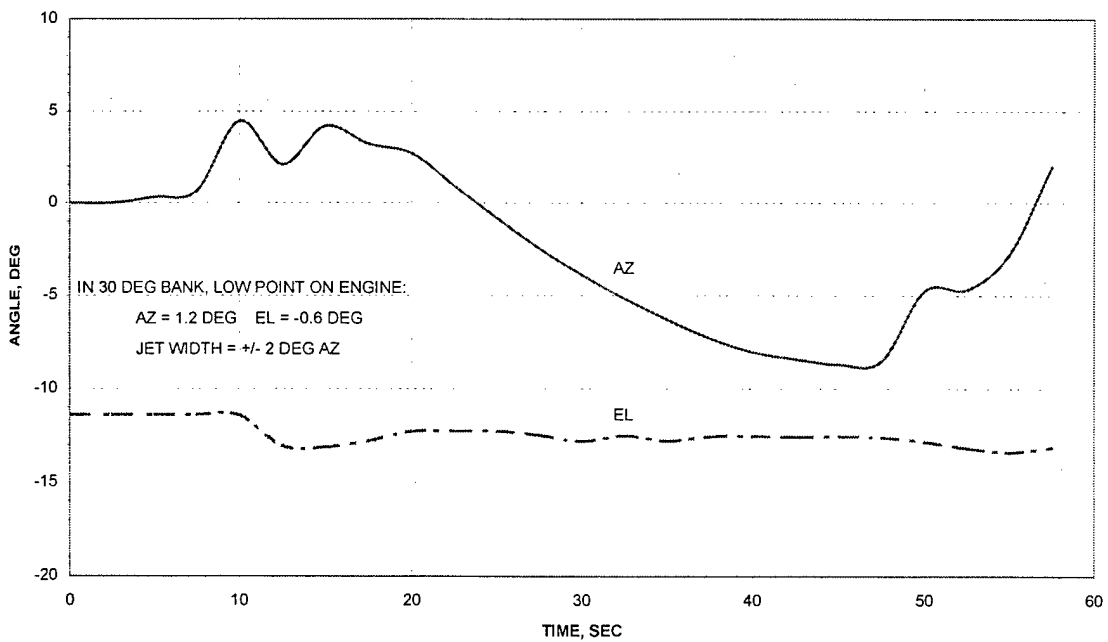

TOW CABLE ANGLE FROM A/C
30 DEG BANKED TURN @ 200 KEAS

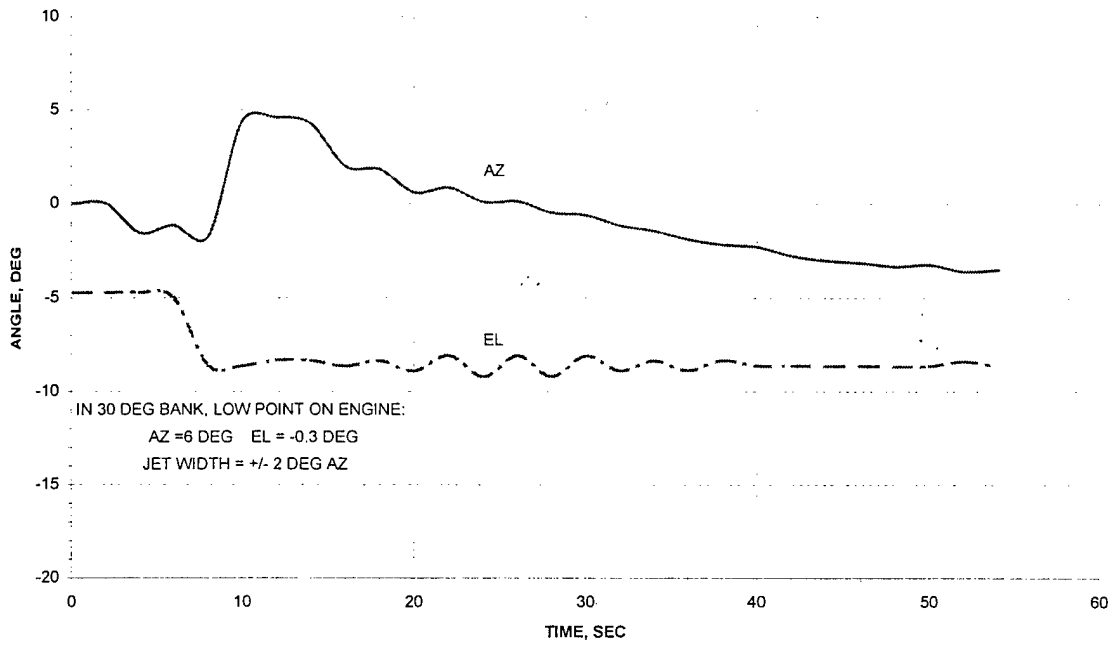

TOW CABLE AZ & EL @ A/C
30 DEG BANKED TURN @ 120 KEAS

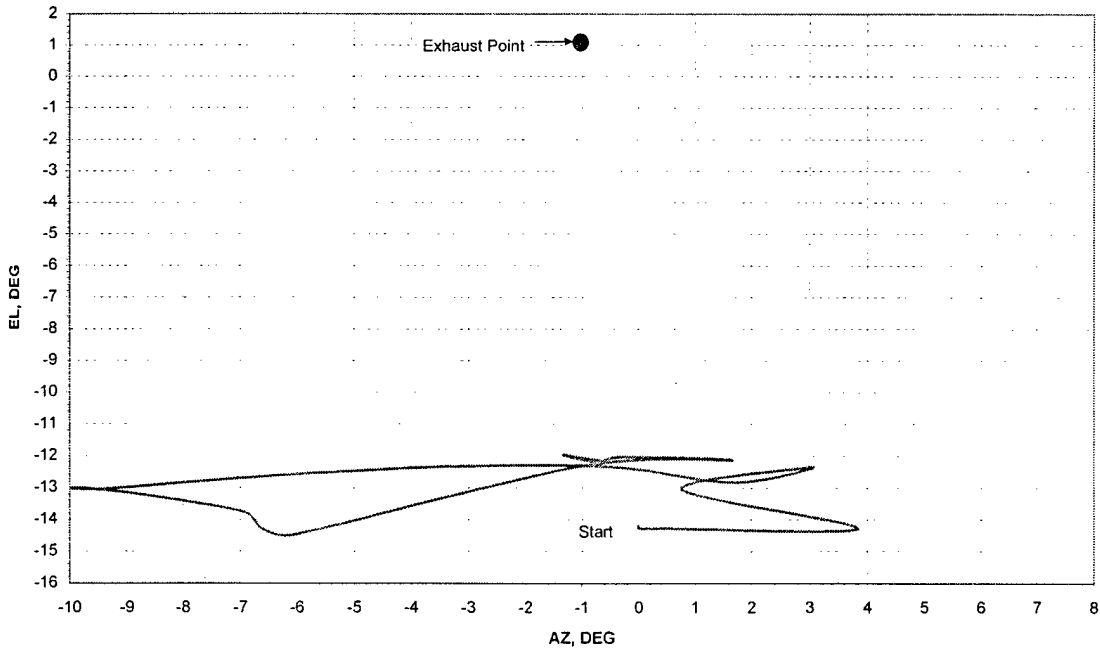

TOW CABLE AZ & EL AT A/C
30 DEG BANKED TURN @ 150 KEAS

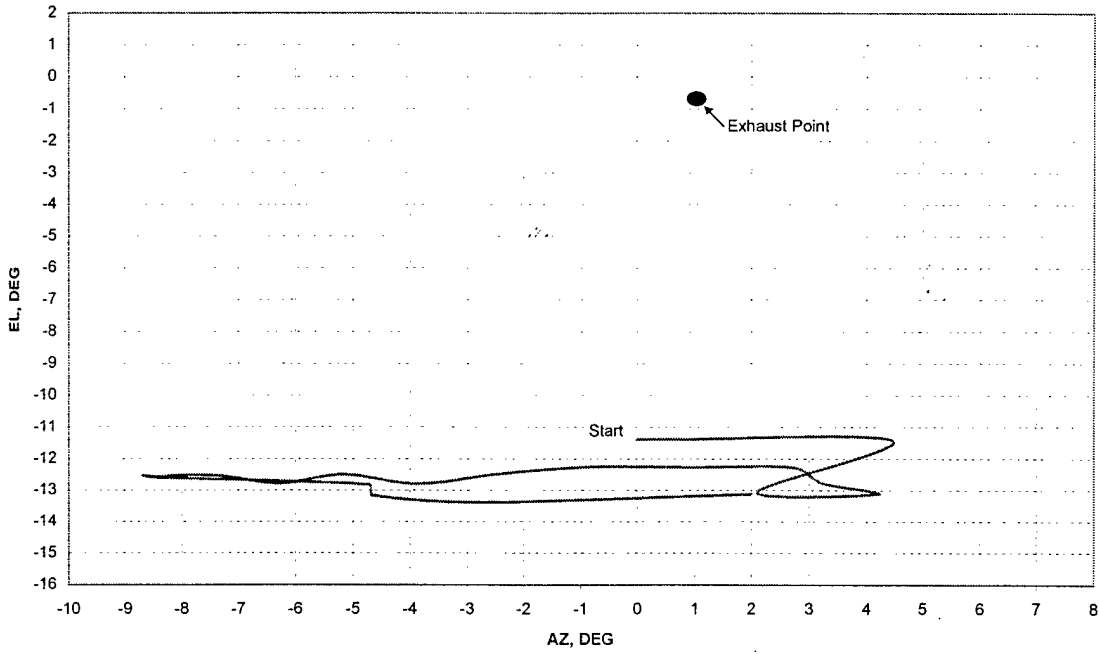

TOW CABLE AZ & EL @ A/C
30 DEG BANKED TURN @ 200 KEAS

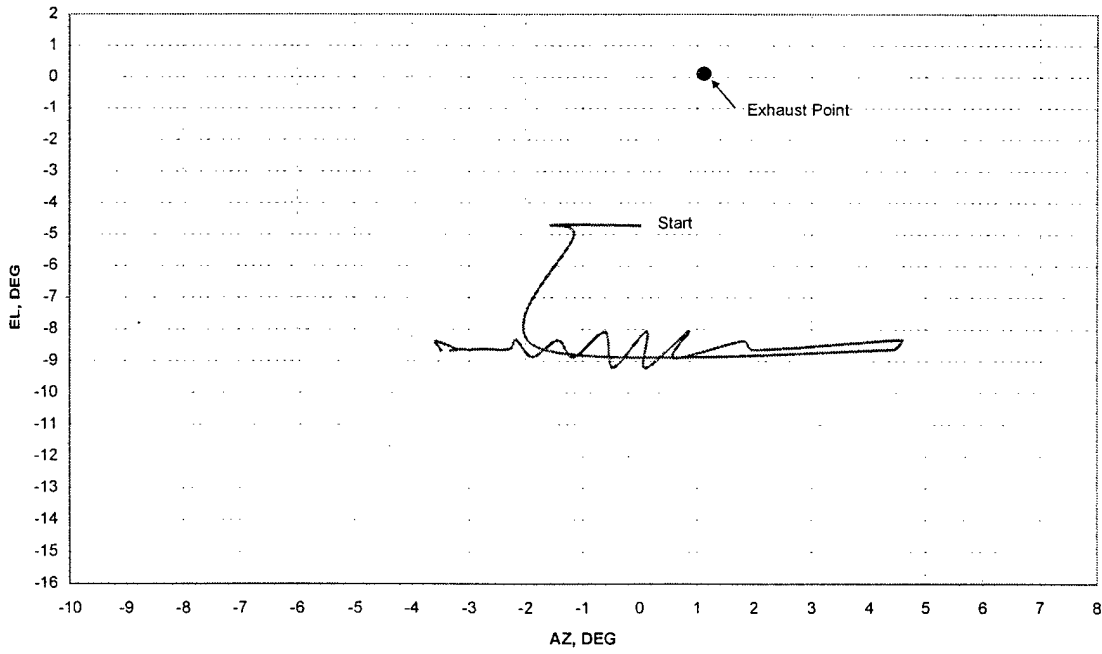

TOW CABLE ANGLE FROM A/C
60 DEG BANKED TURN @ 120 KEAS

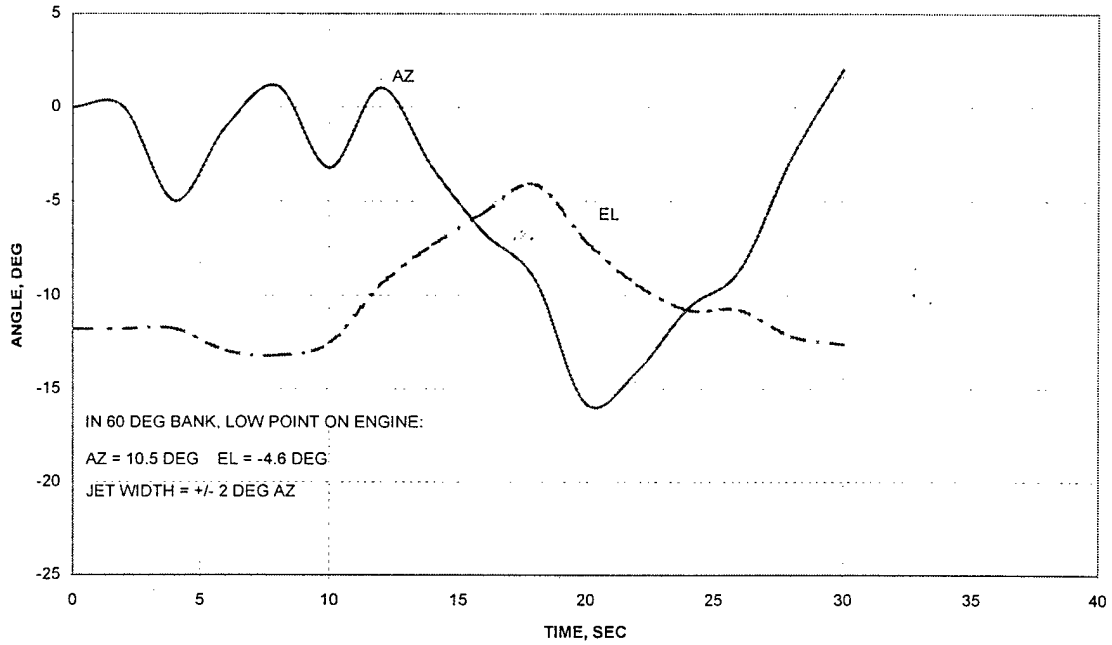

TOW CABLE ANGLE FROM A/C
60 DEG BANKED TURN @ 150 KEAS

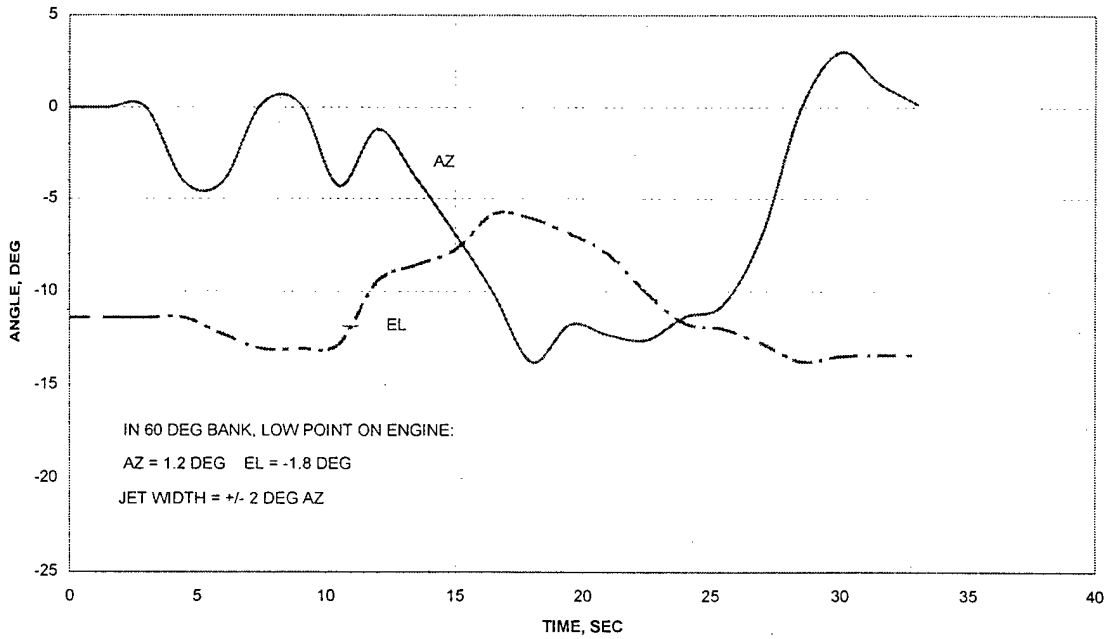

TOW CABLE ANGLE FROM A/C
60 DEG BANKED TURN @ 200 KEAS

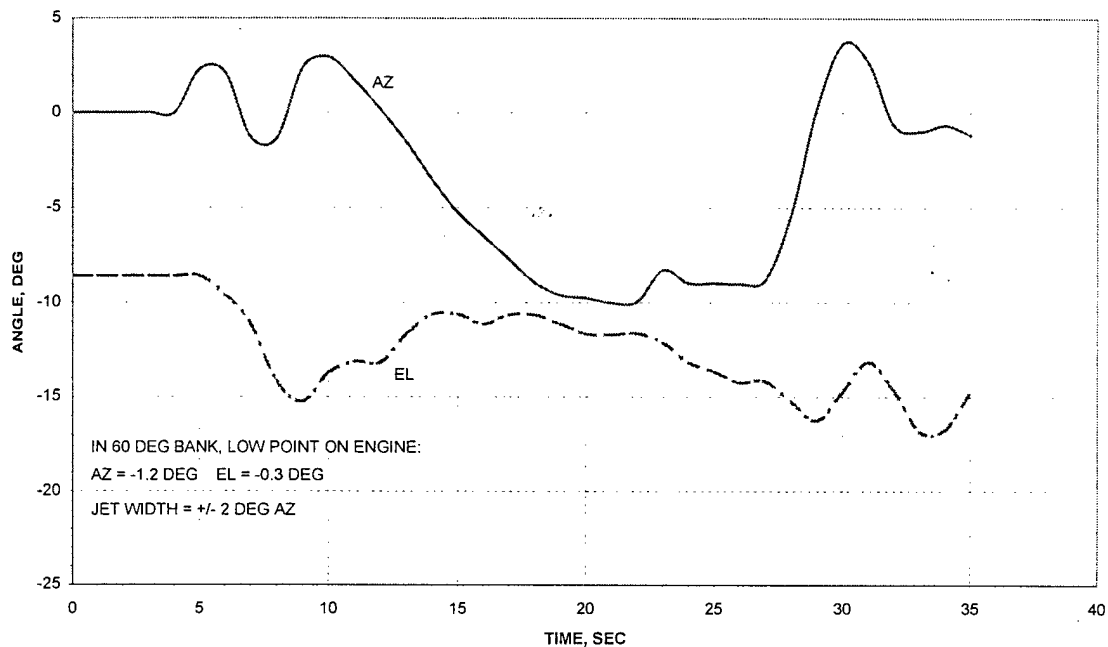

TOW CABLE AZ vs EL AT A/C
60 DEG BANKED TURN @ 120 KEAS

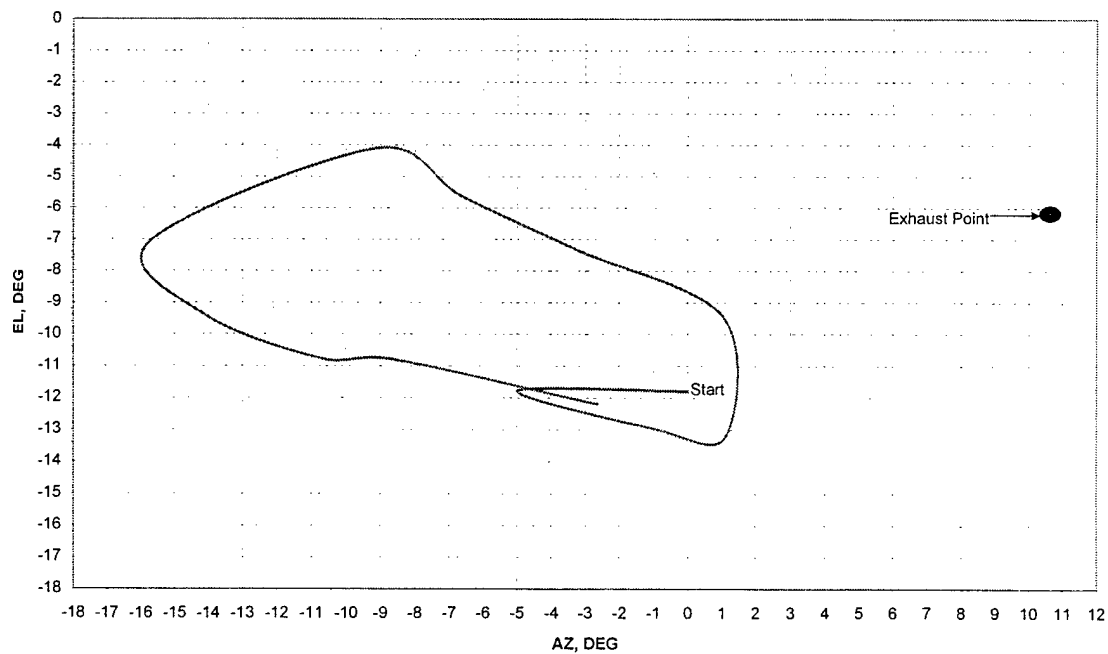

TOW CABLE AZ & EL AT A/C
60 DEG BANKED TURN @ 150 KEAS

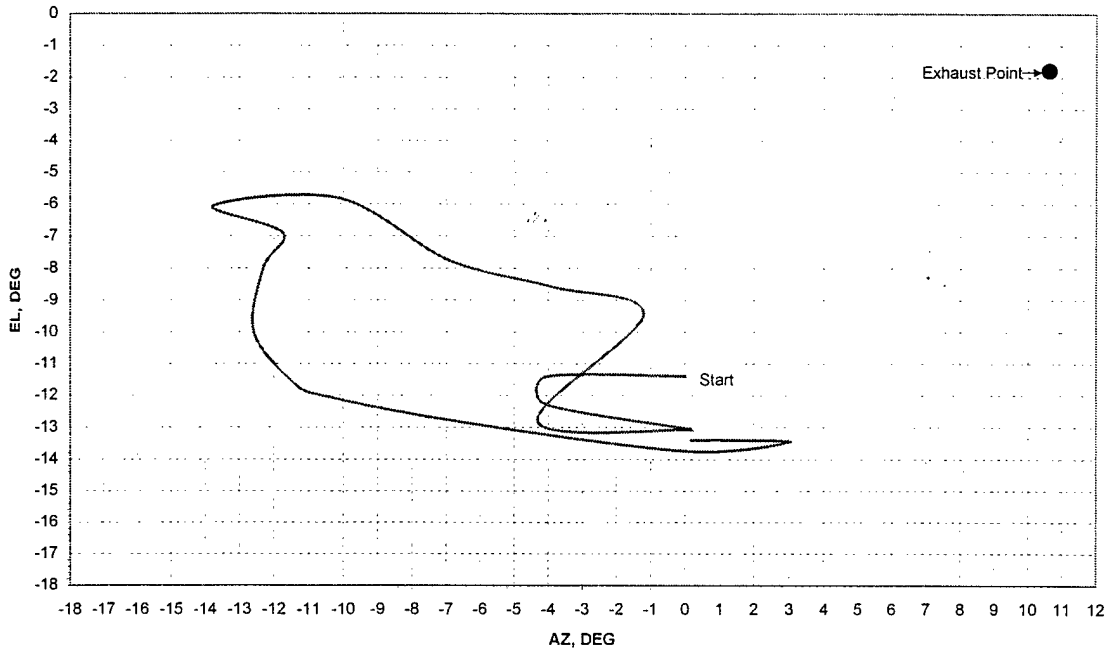

TOW CABLE AZ & EL AT A/C
60 DEG BANKED TURN @ 200 KEAS

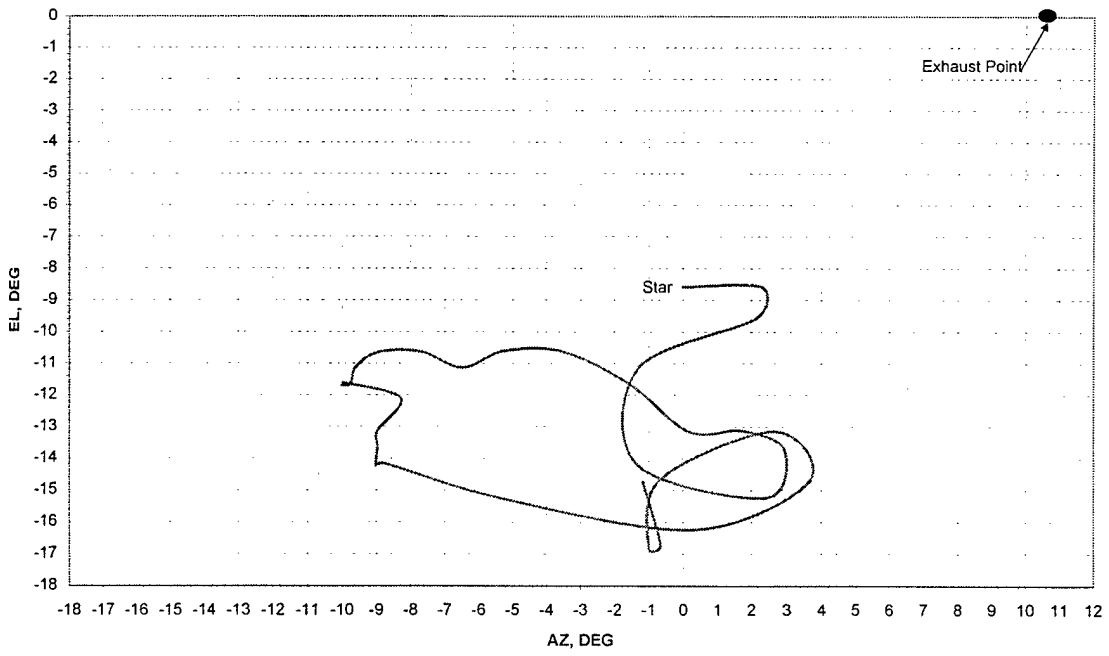

ATTACHMENT 3

A/C ALPHA & THETA IN A TURN

Assume T2C deck angle = 0 deg at a cruise speed of 350 KEAS. Brent Meeker provided the following approximations:

$$\begin{aligned} \text{Wing area, } S &= 255 \text{ ft}^2 \\ dCl/d\text{Alpha} &= 5.7 / \text{rad} = 0.0995^\circ / \text{deg} \end{aligned}$$

Also assume that the aircraft flight weight is 8000 lbs.

At the cruise airspeed and 5000 ft MSL, $q_c = 350$ psf. At the cruise configuration, this results in a lift coefficient of:

$$Cl_c = W / (q * S) = 0.089662$$

This is the condition of zero alpha.

In a banked turn, the lift coefficient is a function of the normal force on the A/C. Since the normal force coefficient, n , at a bank angle of θ deg = $1 / \cos(\theta)$ the lift coefficient becomes:

$$Cl = W / (q * S * \cos(\theta))$$

Thus at a bank angle of 30 deg, $Cl = 0.10353$

And at a bank angle of 60 deg, $Cl = 0.179299$

Including airspeed as a variable, and using the zero alpha Cl and the lift curve slope:

$$\text{Alpha} = q_c / q * (Cl - Cl_c) / dCl/d\text{Alpha}$$

For 120 KEAS: Alpha Exhaust Droop, in

At a bank angle of 30 deg, 1.19 3.23

And at a bank angle of 60 deg, 7.66 20.99

For 150 KEAS:

At a bank angle of 30 deg, 0.76 2.07

And at a bank angle of 60 deg, 4.90 13.39

For 200 KEAS:

At a bank angle of 30 deg, 0.43 1.16

And at a bank angle of 60 deg, 2.76 7.52

The exhaust is approximately 0.4 ft above the tow point in level flight. When the A/C banks left, the left engine moves to the right and down. As the bank angle increases, the left engine crosses over the fixed reference azimuth to become positive. At that point, it also begins to move up.

Looking from the rear, θ_0 of the left engine is $\text{ATAN}(20/42) = 25.5$ deg. Assuming the exhaust point is 42 in below and 20 in to the left of the roll rotation axis of the A/C and the coordinates of the rotation point are $X=0, Y=0$, the following plot can be made:

AZ AND EL OF EXHAUST POINT vs ROLL ANGLE, THETA

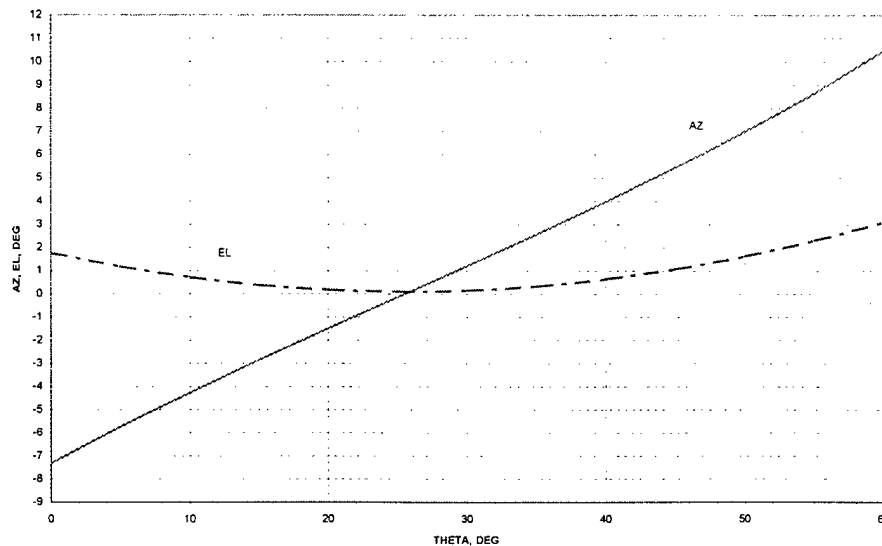

The above plot assumes the tow point to be 0.4 ft below the exhaust point in level flight at zero alpha. By incorporating the effect of alpha with roll at different airspeeds, the following results:

	Alpha Eff, in	Theta Eff, in	Total Drop in	EL, deg	AZ, deg
For 120 KEAS:					
At a bank angle of 30 deg,	-3.23	0.43	-2.80	-1.03	1.22
And at a bank angle of 60 deg,	-20.99	8.48	-12.51	-4.59	10.50
For 150 KEAS:					
At a bank angle of 30 deg,	-2.07	0.43	-1.64	-0.60	1.22
And at a bank angle of 60 deg,	-13.39	8.48	-4.91	-1.80	10.50
For 200 KEAS:					
At a bank angle of 30 deg,	-1.16	0.43	-0.74	-0.27	1.22
And at a bank angle of 60 deg,	-7.52	8.48	0.96	0.35	10.50

The following schedule was used to calculate azimuth (above) is based on the effect of roll in a turn only:

THETA	X	Z
30	3.33	0.43
60	28.90	8.48

By inspection of the chart above, it appears the use of Theta's of 30 and 60 deg are not representative of the potential critical points for coincidence of the cable with the lower left exhaust point. It is recommended that the study be expanded about a roll angle of 25 deg. Also, the entire speed range needs to be explored more thoroughly. Improvements in the approximations of airspeed, weight, and geometry must also be made.

APPENDIX D.
CALCULATION OF T2C EXHAUST RELATIVE TO TOWPOINT
DURING LEVEL TURNS

CALCULATION OF T2C EXHAUST RELATIVE TO TOWPOINT DURING LEVEL TURNS

The T2C has twin engines mounted low on the fuselage as shown in figure 1. The engines are approximately 2.2ft apart, center-to-center. Each exhaust has a diameter of approximately 1.1ft.

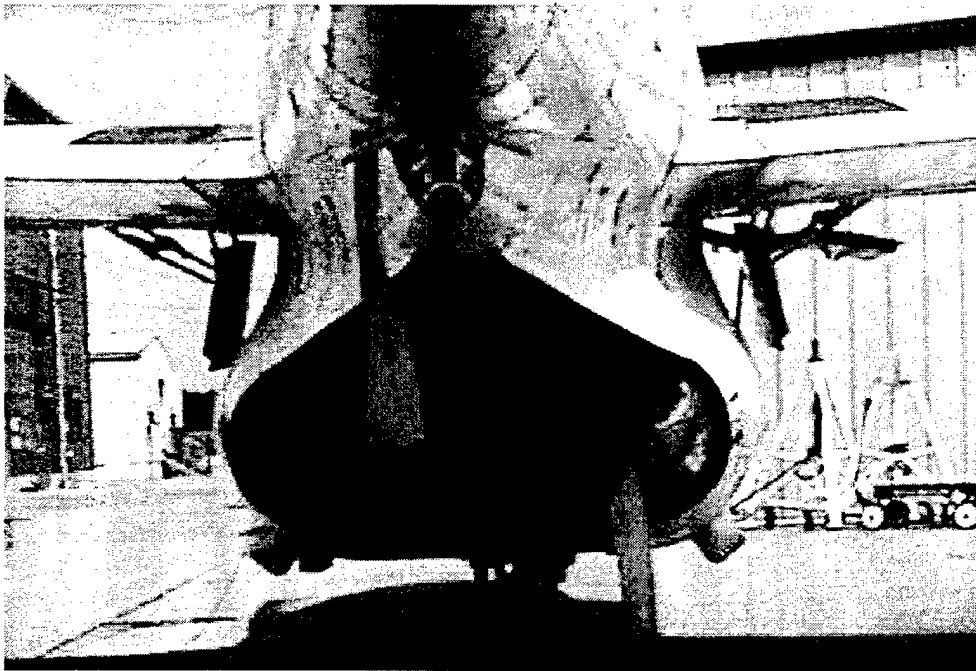

Scaling from figure 2, the tow point is 13.3ft forward of the exhaust on the center-line of the belly. This photograph was taken a 200KEAS in straight and level flight. At this flight condition, the bottom of the exhaust opening is seen to be 0.58ft above the tow point.



In order to determine the relative position of the cable and the exhaust, it is necessary to determine how the relative position of exhaust and tow point vary as the aircraft executes a level, coordinated turn. Define a coordinate system, fixed in the aircraft, with origin at the tow point. Let, Z , be the distance down (when the a/c is level) from the origin. Then the Z -coord of the exhaust is given by

$$Z_{EX} = Z_{EX_0} + \alpha(q, W, N_z)L$$

where α is the angle-of-attack of the aircraft measured relative to its zero-lift line (i.e. the angle-of-attack it has as $q \rightarrow \infty$), q is the dynamic pressure, L is the distance by which the exhaust is behind the tow point, W is the aircraft weight, and N_z is the dorsal load factor. The distance that the exhaust is above the tow point in zero-lift flight, Z_{EX_0} , is unknown. But it can be determined if the weight, wing area, and lift-slope, $C_{L\alpha}$, of the aircraft are known at a particular q , using

$$Z_{EX_0} = Z_{EX}(q) - \frac{WN_z}{qS_{ref}C_{L\alpha}}L \quad (1)$$

The weight is approximately 10,000lb. The wing area is 255ft². Using the DATCOM equation for $C_{L\alpha}$,

$$C_{L\alpha} = \frac{2\pi A}{2 + \sqrt{\frac{A^2 \beta^2}{\kappa^2} \left(1 + \frac{\tan^2 \Lambda}{\beta^2}\right) + 4}}$$

the value, $C_{L\alpha} = 4.48$, is found. Substituting this and the other values into (1) for the particular flight condition of figure 2,

$$\begin{aligned} Z_{EX\infty} &= -0.58 - \frac{10000 * 1.0}{135.5 * 255 * 4.48} 13.3 \\ &= -1.44 \text{ ft} . \end{aligned}$$

So (1) becomes,

$$Z_{EX} = -1.44 + \frac{WN_z}{qS_{ref} C_{L\alpha}} L$$

Rewriting this in terms of the roll angle and air speed in KEAS, gives,

$$Z_{EX} = -1.44 + \frac{2575}{KEAS^2 \cos(\phi)} L ,$$

where ϕ is the roll angle. In order to compare more easily with the plots of tow cable position, rewrite this as the elevation angle of the exhaust, as seen from behind, and measured positive-up from the tow point. This means dividing through by L and reversing the sign (since Z was positive-down).

$$EL = 0.108 - \frac{2575}{KEAS^2 \cos(\phi)}$$

This is in a coordinate system that rolls with the aircraft. So to put it in the coordinates used to plot cable position, rotate back so that the elevation is measured in the vertical direction. In this system the azimuth (lateral displacement of the exhaust) will not be zero as it was in the aircraft system. So

$$el = 0.108 \cos(\phi) - \frac{2575}{KEAS^2}$$

$$az = -0.108 \sin(\phi) + \frac{2575}{KEAS^2} \tan(\phi)$$

Where ϕ is positive for counterclockwise roll looking forward and az is measured positive to the right. Tabulating these values for three air speeds (120, 150, 200) and roll angles (0, 30, 60) yields the following (angles are in degrees):

roll= 0.0 keas= 120. Az= 0.000 El=-4.044
roll= 0.0 keas= 150. Az= 0.000 El=-0.355
roll= 0.0 keas= 200. Az= 0.000 El= 2.515
roll=30.0 keas= 120. Az= 2.815 El=-4.875
roll=30.0 keas= 150. Az= 0.685 El=-1.186
roll=30.0 keas= 200. Az=-0.972 El= 1.683
roll=60.0 keas= 120. Az=12.375 El=-7.146
roll=60.0 keas= 150. Az= 5.986 El=-3.457
roll=60.0 keas= 200. Az= 1.017 El=-0.587

By plotting the exhaust opening over the predicted cable position at the exhaust plane with the bottom center of the exhaust at the tabulated coordinates and orienting the exhaust opening at the roll angle, the clearance between the cable and the exhaust can be seen as shown in the figures of Appendix B