

NAVAL WAR COLLEGE
Newport, R.I.

OPERATIONAL MANEUVER FROM THE SEA:
Opportunity or Vulnerability?

By

Robert T. Tobin
Major, United States Marine Corps

A paper submitted to the Faculty of the Naval War College in partial satisfaction of the requirements of the Department of Joint Military Operations.

The contents of this paper reflect my own personal views and are not necessarily endorsed by the Naval War College or the Department of the Navy.

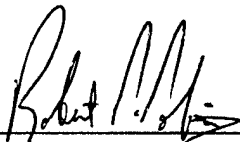
Signature:  _____

5 February 2001

Colonel Dyer Lennox, USMC
Faculty Advisor

20010510 125

REPORT DOCUMENTATION PAGE

1. Report Security Classification: UNCLASSIFIED			
2. Security Classification Authority: N/A			
3. Declassification/Downgrading Schedule: N/A			
4. Distribution/Availability of Report: DISTRIBUTION STATEMENT A: APPROVED FOR PUBLIC RELEASE; DISTRIBUTION IS UNLIMITED.			
5. Name of Performing Organization: JOINT MILITARY OPERATIONS DEPARTMENT			
6. Office Symbol: C		7. Address: NAVAL WAR COLLEGE 686 CUSHING ROAD NEWPORT, RI 02841-1207	
8. Title (Include Security Classification): OPERATIONAL MANEUVER FROM THE SEA: Opportunity or Vulnerability? (U)			
9. Personal Authors: MAJOR ROBERT T. TOBIN, U.S. MARINE CORPS			
10. Type of Report: FINAL		11. Date of Report: 05 FEBRUARY 2001	
12. Page Count: 32		12A Paper Advisor (if any): COLONEL DYER LENNOX, USMC	
13. Supplementary Notation: A paper submitted to the Faculty of the NWC in partial satisfaction of the requirements of the JMO Department. The contents of this paper reflect my own personal views and are not necessarily endorsed by the NWC or the Department of the Navy.			
14. Ten key words that relate to your paper: OMFTS, STOM, VERTICAL ASSAULT, SUSTAINMENT, AMPHIBIOUS ASSAULT, MEB 2010, AIRBORNE LOGISTICS, MV-22.			
15. Abstract: <p>The Marine Corps continues to prepare and organize its forces for the 21st century under the strategic guidance established in JV 2020. As the concepts of OMFTS and STOM mature, the Marine Corps must <i>honestly</i> assess its expectations against its realistic capabilities.</p> <p>Under the auspices of OMFTS, the Osprey tilt-rotor aircraft (MV-22), Landing Craft Air Cushion (LCAC), and Advanced Amphibious Assault Vehicle (AAAV) promise to provide a decisive power projection capability for future Commanders-In-Chiefs and Joint Force Commanders. However, as many warfighters will attest, getting to the objective is only half the battle. The complex, critically substantial, task of sustaining rapidly maneuvering combat forces ashore will determine the success of future missions.</p> <p>This paper will analyze the Marine Corps' future warfighting concepts of OMFTS and STOM. As the speed and range of operational maneuver increases exponentially with the introduction of new technology, these concepts will reincarnate previously learned lessons of airborne sustainment and expose their critical vulnerability—an over-reliance on aviation. The time is now to seriously consider the boundaries of OMFTS and STOM in relation to space, force and time.</p>			
16. Distribution / Availability of Abstract:	Unclassified X	Same As Rpt	DTIC Users
17. Abstract Security Classification: UNCLASSIFIED			
18. Name of Responsible Individual: CHAIRMAN, JOINT MILITARY OPERATIONS DEPARTMENT			
19. Telephone: 841-6461		20. Office Symbol: C	

Abstract of

OPERATIONAL MANEUVER FROM THE SEA:
Opportunity or Vulnerability?

The Marine Corps continues to prepare and organize its forces for the 21st century under the strategic guidance established in JV 2020. As the concepts of OMFTS and STOM mature, the Marine Corps must *honestly* assess its expectations against its realistic capabilities.

Under the auspices of OMFTS, the Osprey tilt-rotor aircraft (MV-22), Landing Craft Air Cushion (LCAC), and Advanced Amphibious Assault Vehicle (AAAV) promise to provide a decisive power projection capability for future Commanders-In-Chiefs and Joint Force Commanders. However, as many warfighters will attest, getting to the objective is only half the battle. The complex, critically substantial, task of sustaining rapidly maneuvering combat forces ashore will determine the success of future missions.

This paper will analyze the Marine Corps' future warfighting concepts of OMFTS and STOM. As the speed and range of operational maneuver increases exponentially with the introduction of new technology, these concepts will reincarnate previously learned lessons of airborne sustainment and expose their critical vulnerability—an over-reliance on aviation. The time is now to seriously consider the boundaries of OMFTS and STOM in relation to space, force and time.

TABLE OF CONTENTS

INTRODUCTION.....	1
HISTORICAL OVERVIEW.....	3
FUTURE SCENARIO.....	5
ANALYSIS.....	9
Figure 1. Over-land resupply timeline.....	11
Figure 2. Vertical lift resupply timeline.....	11
Figure 3. Maximum supportable range.....	12
CONCLUSIONS.....	14
RECOMMENDATIONS.....	15
SUMMARY.....	18
NOTES.....	19
BIBLIOGRAPHY.....	21
APPENDIX A.....	A-1
APPENDIX B.....	B-1
APPENDIX C.....	C-1

INTRODUCTION

As the United States enters the 21st century, its military forces will continue to be called upon to promote national interests and win the Nation's battles. Our National Security Strategy (NSS) provides foundational guidelines for the development and employment of our military forces in support of national objectives. The ability to rapidly respond to a crisis is critical. "Equally essential is effective global power projection, which is key to the flexibility demanded of our forces and provides options for responding to potential crises and conflicts even when we have no permanent presence or limited infrastructure in a region".¹

Today, the Department of Defense is undergoing a transformation to become more expeditionary, flexible and self-sufficient. History is replete with examples of nations or states transforming and capitalizing upon new technologies and military revolutions. Generally, these changes offer great advantages to those who exploit them over adversaries who fail to realize the changing character of future warfare.² Joint Vision 2020 (JV 2020) recognizes the importance of innovation in regards to military operations. The goal of JV 2020 is the creation of a force that is dominant across the full spectrum of military operations. This vision encourages the implementation of technological advances and innovation into the U.S. military. It also emphasizes the importance of co-developing technological and intellectual innovation towards the changes in organization and doctrine.³

In the white papers, "...From the Sea" and "Forward...From the Sea," the Navy and Marine Corps are together developing a new approach to naval operations. Operational Maneuver From the Sea (OMFTS) and Ship-To-Objective Maneuver (STOM) represent the Marine Corps' capstone warfighting concepts and maneuver warfare philosophy to power projection in the 21st century.⁴

Future Commanders-in-Chiefs (CINCs) and Joint Force Commanders (JFCs) will inevitably consider employing Marine Corps combat units to deter aggression or decisively attack an adversary's vulnerability, based upon the developing concepts of OMFTS and STOM. The projection of an amphibious power, which reaches deep inland, maximizes the benefits of speed and maneuver, and is capable of traveling great distances at sea and ashore, provides amazing potential to influence the operational level of war. However, as many warfighters will attest, getting to the objective is only half the battle. The complex, critically substantial, task of sustaining the forces ashore—with a growing dependence on aviation—will determine the success of future missions and define the boundaries of OMFTS/STOM in relation to space, force and time.

THESIS

OMFTS and STOM provide great strategic, operational, and tactical flexibility, but they also possess potentially dangerous flaws. At the operational level of war, OMFTS cannot support rapid operational maneuver *and* operational sustainment due to its unconditional dependence on Marine Aviation. OMFTS creates serious vulnerabilities for ground forces employed at extended ranges. This paper will analyze the Marine Corps' future warfighting concepts of OMFTS and STOM. Specific attention will focus on the critical vulnerabilities of employing and supporting a Marine Expeditionary Brigade (MEB) ashore with resident aviation assets. Is there a mismatch between the Marine Corps' concepts and expected capabilities? How does OMFTS influence a warfighting CINC's consideration of space, force and time?

To provide a logical progression, this analysis will review some key historical lessons to establish a foundation of reference underscoring the magnitude of the sustainment challenge, its significance, and considerations experienced in past conflicts. As the concepts of OMFTS and STOM mature, they will evolve reliant on the combined capabilities of a “mobility triad”, the Osprey tilt-rotor aircraft (MV-22), Landing Craft Air Cushion (LCAC), and Advanced Amphibious Assault Vehicle (AAAV). As the Marine Corps continues to prepare and organize under the strategic guidance established in JV 2020, it must candidly compare its actual capabilities verses its expectations, and deliberate how these results influence a likely and probable future scenario. Only from this viewpoint can one extrapolate the lessons of the past and synthesis them into productive recommendations for the future.

HISTORICAL VIEW

Although Operational Maneuver From the Sea and Ship-To-Objective Maneuver are relatively new concepts, the basic underlying requirements of maneuver and logistical sustainment have been individually combat proven and tested. With the combined effects of speed and mobility, maneuvering ground forces will become ever increasingly dependent on an expeditious means for logistical support. This task proves increasingly more difficult as penetration ranges and operational tempo increase.

Historically, the amount of logistical supplies needed to sustain operations has not decreased. It seems fundamental to human nature that as technology improves, greater amounts of firepower are brought to bear on the enemy and greater amounts, not less, of logistical support are required. This reality, coupled with the desire to place combat forces

faster and further into enemy territory, has fostered dependence for vital support to be delivered by airborne methods. There are few cases that identify the successful supportability of large ground units by aviation assets. Marines at Khe Sahn, who fought from a static fire support base, had their support requirements fulfilled by land based fixed and rotary winged aircraft. "The key to this extraordinary effort lay in the helicopter and the tactical transport aircraft...Neither would have been effective unless the Americans had total air superiority."⁵ During World War II, General Slim's British 14th Army, which was foot mobile and fighting in the jungle of Burma, was also sustained by air. More commonplace is examples of various sized units unable to sustain themselves and reach victory relying on a lifeline of airborne sustainment.

During the battle at Stalingrad, the German 6th Army staff anticipated 700 tons of supplies would be required, per day, to sustain combat operations.⁶ Despite their best efforts, the 6th Army dwindled on the vine. They actually received a comparatively meager 140 tons per day of air delivered supplies during December 1942 and 60 tons a day during January 1943. The German's effective combat power and ability to resist evaporated, as aviation assets were unable to provide sufficient supplies of food, fuel and ammunition. This vulnerable airborne bridge led to the attrition and surrender of these German forces.⁷

Ten years prior to the Marines logistical success in Viet Nam, the French at Dien Bien Phu suffered a decisive defeat by attempting to link operational success with the requirement for airborne sustainment. French forces were inserted by air 150 miles from their base of operations and relied on airborne lines of operations for sustainment. They accumulated six days of supplies at their forward position prior to the sustained combat engagement with the Vietminh forces.⁸ The Vietminh forces recognized their opponent's

vulnerability and neutralized the airfield's runway causing the French to attempt resupply via parachute drop. These airborne sustainment operations became insufficient due to their extreme vulnerability to Anti-Aircraft Artillery and prohibitive weather conditions.⁹

Conceptually, the tenants of OMFTS and STOM mitigate the aforementioned "Achilles' heel" of an "air-bridge" by combining both air and ground transport as a means for sustainment, providing multi-axis redundancy. However, with the continued proliferation of shoulder-fired surface-to-air missiles (MANPADS) and the expected acquisition of unprotected aircraft, this "air-bridge" will continue to be at risk. Additionally, as the speed and range of operational maneuver increases exponentially with the introduction of new technology aircraft, the OMFTS concept will reincarnate previously learned lessons of airborne sustainment and expose its critical vulnerability—an over-reliance on aviation.

FUTURE SCENARIO

In the future, it is very likely that United States forces will be utilized to promote and protect national interests overseas. For the purpose of analysis, a fictitious potential scenario involving U.S. forces will be developed. The year is 2010. The United States Navy has procured and is operating its line of amphibious transport dock ships (LPD-17). The Marine Corps has also successfully acquired its future warfighting platforms. These systems include the MV-22, AAV, AH-1Z, UH-1Y, as well as legacy platforms such as the CH-53E and LCAC. Although U.S. naval forces have control of key sea lines of communications (SLOCs) and joint air forces have air superiority, sea-mines and anti-ship missile threats prohibit movement for a sea-based force to proceed directly to its land-based objective.

The National Command Authority (NCA) and the theater CINC have determined that military action is needed to protect America's vital interest in the region. There is currently no host nation support; access to deep-water ports is restricted at this time, although Maritime Prepositioning Ships (MPS) are enroute. An initial concept of operation developed by the Joint Task Force (JTF) Commander has been approved. The plan utilizes a Marine Expeditionary Brigade (MEB) as the force to initiate actions ashore, and if needed, provide access for follow-on forces. To facilitate access to the region, the MEB will have to be embarked upon amphibious shipping and sustain itself through sea-based logistics. Various configurations of naval amphibious ships could be deployed to support this mission. For the scope of this analysis, assume the required ships to embark a MEB—comprised of a Command Element (CE), reinforced Regimental Landing Team (RLT), composite Marine Aircraft Group (MAG), and a Brigade Service Support Group (BSSG)—are available.¹⁰ Prerequisite reconnaissance, hydrographic study, and deception operations are ongoing to reduce operational risk and facilitate mission accomplishment.

The MEB's mission is to conduct an amphibious assault to seize JTF Objectives Alpha, Bravo, and Charlie (A, B, C), conduct offensive operations in sector in order to clear enemy forces, allow the entry of follow-on forces, and promote regional stability (See map, appendix A). Due to the existing threat environment and assigned mission, an over-the-horizon assault utilizing the doctrinal concepts of OMFTS and STOM will be utilized.

The MEB's concept of operations for the amphibious assault is as follows: the 1st Battalion is to seize Objective A via surface assault (using AAV's) through Littoral Penetration Site 1 (LPS 1), 2nd Battalion will seize Objective B via vertical assault (in MV-22's and CH-53E's) also through LPS 1, and the 3rd Battalion is to seize Objective C via

surface assault (using AAV's) through LPS 2. Subsequent assault waves would transport Combat Service Support (CSS) equipment, the artillery battalion, and elements of the BSSG using a combination of vertical lift and surface craft (LCAC/LCU). The Regimental Landing Team (RLT) will disembark amphibious shipping from 25 nautical miles off shore. 1st Battalion will travel 30 miles inland to Objective A. 2nd Battalion will be vertically inserted 50 miles inland in the vicinity of Objective B. 3rd Battalion will proceed 5 miles inland to reach Objective C¹¹. A link-up will occur between 1st and 2nd Battalions once Objective A is secured no later than D+4. The JTF Commander has emphasized the importance for a rapid projection of decisive combat power, utilizing speed of maneuver to engage the enemy's critical vulnerabilities. "Winning will be determined by the speed with which we can respond and the effectiveness and survivability of the forces that we deliver. If we're going to be successful on these fronts, the unique capabilities of Marine aviation will be key."¹²

QUALIFIER: It is important to recognize that a multitude of factors drive the execution of an amphibious assault. Many of these factors—training, experience, proficiency, and unit readiness—are difficult at best to quantify. Additionally, prioritization of landing force serials, aircraft and surface craft maintenance availability, crew day limitations for aircrew and flight/well deck personnel, and load times substantially influence the speed and efficiency of any operation. For the purpose of this scenario, these issues will be considered optimal. The Area of Operation (AO) will also be conducive to an amphibious landing; with permissive terrain inland for the rapid advancement of mechanized and wheel mobile platforms.

The MEB's initial waves commence the assault on D-Day at H-Hour, 0000 local. The first wave departs as planned due to the pre-loading of air/landing craft. The AAAV's will ingress from the sea to their respective LPS at a planned 20 knots and proceed overland to their objectives in accordance with doctrinal rates of advance found in FM 7-123.¹³ Vertical lift assets—MV-22 and CH-53E—initially ingressed to Objective B at 240 knots and 135 knots respectively. Subsequent waves of MV-22 support will ingress significantly slower (100-140 knots) due to the limitations imposed by the externally transported supplies and support equipment.¹⁴ As the operation progresses, the normal potential friction created by the convergence of assault platforms returning to the "sea-base" and those departing for the objective area, as well as attrition caused by either enemy or mechanical reasons, will undoubtedly dictate the rate of the MEB's flow ashore. The combat service support vehicles are marshaled ashore and convoy logistical supplies to Objective's A and C. Averaging 10-15 miles per hour, their movement and employment is consistent with the templates established in FM 7-123.

Under the guidelines of this most favorable scenario, numerical tabulation confirms that the MEB can execute STOM. The combat elements of the vertically inserted 2nd Battalion would be in place by 0715 on D-Day. The forces slated for operations in the vicinity of Objective A would receive all preplanned forces on D+2 at 0100 (H+48), as they had the priority for off-load and logistical support. Objective C could also receive its forces by 2100 on D+1 (H+44) (See Appendix C).¹⁵ This scenario clearly demonstrates that a future MEB can *feasibly* execute the concepts of OMFTS and STOM to conduct an amphibious landing. However, upon a successful assault and insertion of the MEB ashore, the equally immense challenge of sustaining these forces begins.

ANALYSIS

As a MEB sized force operates ashore, the Commander will be faced with the immense challenge of balancing Operational Maneuver—emphasizing speed and mobility—with the need to sustain his forces. One detailed study indicates that based on logical assumptions regarding consumption rates for fuel, food, water, and ammunition, a MEB in 2010 will require 562,591 pounds of air-delivered logistics to support operations by D+2 in order to pursue further offensive action.¹⁶ In the scenario presented earlier, 2nd Battalion was vertically inserted in the vicinity of Objective B and remained "foot mobile." One can question just how much relative speed and operational tempo can be maintained by foot mobile infantry units on the modern battlefield. Recent experimentation conducted by the Marine Corps Warfighting Laboratory concluded, "Foot-mobile Marines continue to carry packs that are too large for effective maneuver."¹⁷ Therefore, their operational maneuver advantage, relative to an enemy's ability to react, is highly dependent upon Marine aviation's ability to quickly reposition the force as needed, to exploit enemy weaknesses, and reduce the limitations imposed by terrain.¹⁸ At the same time, the unit's dependency for timely resupply will rely heavily on Marine aviation due to the speed and distances in which the force is now re-deployed. Conceptually, traditional over-land resupply units would not be able to adjust enroute and solve the time-distance-speed problem created by this expeditious maneuver. Without the luxury of an operational pause, 2nd Battalion would be faced with the dilemma of competing priorities, *maneuver or sustainment*.

Is there a mismatch developing in the Marine Corps' ability to both maneuver and sustain its combat force? Once the MEB's 5,700 Marines and 1,190 vehicles and trailers are ashore, their vehicles will carry 83,708 gallons of fuel in their tanks.¹⁹ AAV's launching

from 25 miles off shore could travel a maximum of 250 miles overland given expected fuel capacities. Assuming 50% of the ground force's onboard fuel is consumed, 41,890 gallons, a resupply requirement of eighty-four 500 gallon bladders, plus pumping equipment, will develop. Direct Support BSSG assets could carry up to 42,810 gallons of fuel, but they would be forced to exclude other items—water, food, and ammunition—required for sustainment operations in order to carry the fuel load. "Historical usage rates for artillery [alone] indicate the MEB [of 2010] could fire all 2,880 rounds carried on organic transportation in one day, causing a resupply requirement that BSSG motor transport assets could not fulfill in one day unless every vehicle in the GS MCSSD and DS MCSSD were mobilized."²⁰ Clearly, the reliance on airborne vertical-lift support will become increasingly crucial to augment the BSSG's tasking, in addition to providing food, water, other ammunition, and casualty evacuation (CASEVAC) operations for the MEB's ground forces. A classic "Catch-22" materializes as finite aircraft sorties are allocated to conduct resupply and/or maneuver missions. This jeopardy escalates as ranges and maneuver speeds increase.

The mismatch can be further exemplified by the following simple time-distance-speed problem. Assume ground forces were 50 miles inland from their resupply point. A Medium Tactical Vehicle Replacement (MTVR), capable of carrying 14,000 pounds cross-country, would take 12 hours—including loading and unloading times—to complete a round trip over-land resupply.²¹ If forces are maneuvered, and the distance increases by 50 miles, the same resupply would take an additional 8 hours, assuming the MTVR driver knew of the change before leaving the staging area (See figure 1). Comparatively, if this same resupply mission were assigned to a CH-53E, carrying the same 14,000 pound load, the original one-

hour round trip would increase only 52 minutes total by the additional 50 miles (See figure 2).

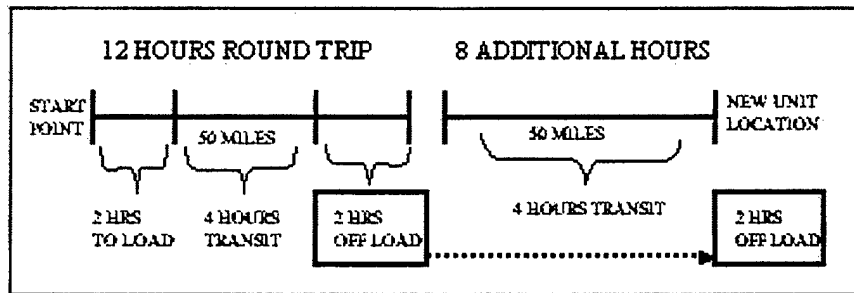

Figure 1. Over-land resupply timeline

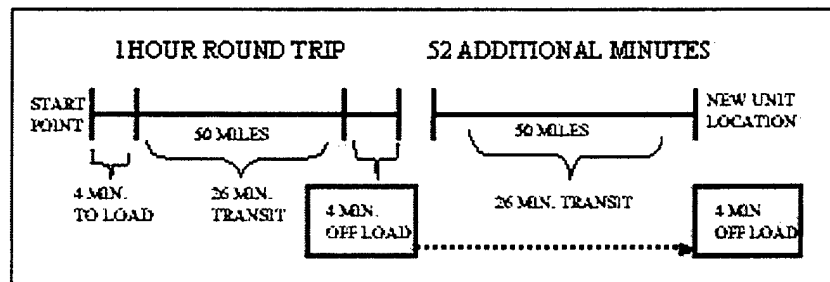

Figure 2. Vertical lift resupply timeline

This demonstrates the consequence of time relative to distance while attempting to sustain a maneuvering force, and its significance is relatively greater on surface lift than vertical lift. Compounding this challenge, one must consider the extended lines of communications (LOCs) required if over-land supply routes attempt to sustain forces deep inland. These LOC's will require protection and security, similar to combat service support areas in a traditional amphibious operation, and defy some of the proposed advantages of OMFTS, STOM, and sea-based logistics. This simple demonstration illustrates the propensity for ground forces employing OMFTS to become ever more dependent on limited aviation assets for sustainment, in addition to maneuver. A critical mismatch—vulnerability—does exist if air-mobile combat forces are maneuvered, and aviation assets cannot conduct sustainment

operations due to weather, threats, or aircraft availability. This risk increases proportionally with distance and is inversely related to the time available prior to logistical exhaustion or unit culmination.

The supportability of a future MEB, up to this point, has assumed aircraft movement to be unopposed. Realistically, even though joint forces may have "air-superiority" above 10,000 feet, as recently demonstrated in Kosovo, enemy contact with slow moving, low-flying aircraft will undoubtedly degrade our ability to conduct maneuver and sustainment operations. By anticipating aircraft losses due to enemy action, in a contested low altitude environment, the factors of time, force, and space become even more significant and further highlight the vulnerabilities of a MEB that relies primarily on aircraft for sustainment and mobility. The distance in which a MAGTF can support inland operations will decrease as time increases due to the cumulative loss of available aircraft (See Figure 3)²². This

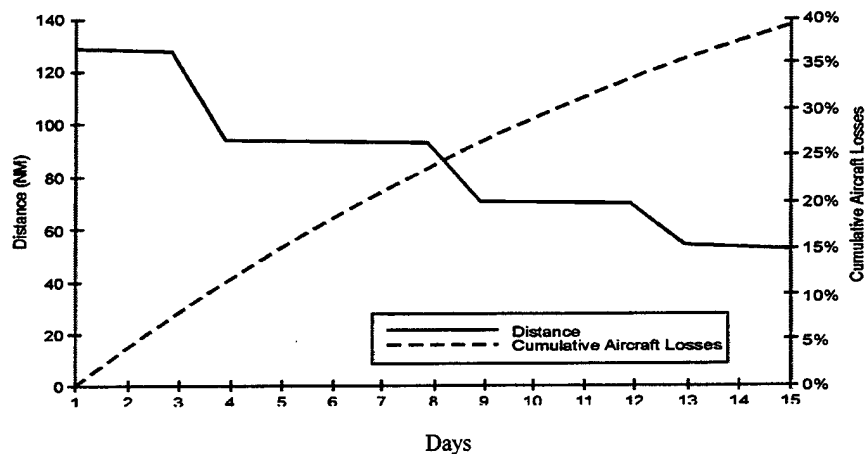

Figure 3. Maximum Supportable Range in a Non-Permissive Environment

translates directly into the number of sorties that may be generated for support. In the previous scenario, the MEB would require 94 sorties per day for sustainment. Assuming 80% aircraft availability on D-Day, the ACE would have 48 aircraft available. Although the MEB's requirements are supportable initially, the ACE's attrition would begin to constrain

the actions of the MEB by D+7. As other sorties are required to maneuver forces, in addition to resupplying them, the reliance on aviation assets becomes troublesome.

One of the cornerstones of OMFTS is a reduced requirement for logistics ashore. "In the near future, improvements in the precision of long-range weapons, greater reliance on sea-based fire support, and, quite possibly, a decrease in the fuel requirements of military land vehicles promise to eliminate, or at least greatly reduce, the need to establish supply facilities ashore. As a result, the logistics tail of landing forces will be smaller..."²³ These assertions may apply to the logistical tail of follow-on landing forces, but the requirements to support operating combat forces contradict these assumptions and historical experience. The physical amounts of total logistics to support a MEB sized combat force ashore shows no substantiated signs of decreasing.

At the operational level of war, successful employment of OMFTS will mandate a comprehensive understanding and a realistic balance of the factors of space, time, and forces. "The art of warfare at all levels is to obtain and maintain freedom of action...Freedom of action is the key prerequisite for obtaining the initiative, which, in turn, creates the necessary conditions for a military commander to further enlarge his freedom of action."²⁴ As maneuver speed and range increase to gain tactical advantage on the battlefield and exploit enemy vulnerabilities, our forces will be enticed to overlook the growing challenge of sustainment resulting from the scope of this maneuvering. *The United States Marine Corps is on the threshold of future tactical mobility that is capable of exceeding the boundaries of operational sustainment.* The duration of an operation, the speed and space of movement, or the size of the force employed will less likely be restrained by our enemy's ability to resist and more likely constrained by our ability to support it.

CONCLUSIONS

“Students of warfare should not be content with studying Strategy and Tactics in the abstract and concrete. The mere fact that a measure may be correctly founded on strategical or tactical principles is not conclusive that such measure is acceptable or that it may be adopted.”²⁵ Meticulous analytical study combined with unemotional, intellectual honesty will ensure the further success and refinement of the OMFTS concepts. This analysis reaches the following conclusions. It is *feasible* for a future Marine Air Ground Task Force (MAGTF), of varying size, to operationally execute these concepts provided expected systems are acquired and funded. However, when these concepts are applied to a realistic analysis, which include sustained operations and interaction with an enemy, serious limitations develop. OMFTS creates critical vulnerabilities for ground forces employed at extended ranges. The deeper and faster units maneuver into an enemy's territory, the greater the reliance will be on airborne sustainment. History has proven absolute reliance on "air-bridges" to be precarious at best. For the Marine Corps "...to realize the full value of OMFTS, there must be either a shift to more lethal landing forces having smaller logistical demands or a sizable increase in airlift capability."²⁶ The elements of maneuver or sustainment can be individually accomplished by aviation, but this analysis concludes that these elements cannot occur simultaneously at the operational level of war. A compromise based on priorities, the factors of space-time-forces, and careful allocation of limited assets is essential to reduce risk and ensure the success of OMFTS.

RECOMMENDATIONS

The forces employed to fight tomorrow's battles must become more self-reliant, "such is the nature of logistics in the maneuver style of warfare."²⁷ OMFTS emphasizes a desire to reduce the restrictions of shore-based logistics, but to maximize its full potential, original and creative ideas need to be further explored in order to reduce the previously identified vulnerabilities. The following ideas are presented, not as a matter of certainty, but for future consideration and to stimulate innovation.

Creativity: The review of historical lessons learned and the development of new equipment to do current jobs better, may at times limit ones thinking to search for ways to make the wheel rounder. Today, the Marine Corps' concept to sustain an OMFTS operation ashore is essentially based upon the traditional idea of bringing logistics support to the combat units in the field, originating from the sea or land based supply centers. If one presumes future wars will be focused on attacking enemy vulnerabilities, rather than occupying terrain, and contact with the enemy will occur at the time and place of our choosing, then complimentary concepts to OMFTS need further experimentation. For instance, as the advancements in tactical mobility increase, assets could use their strengths—speed, range, and mobility—not to resupply forces directly, but instead they could extract combat forces as the need for resupply becomes apparent, and maneuver the force to a logistics resupply point, either on land or at sea, enroute to its next objective. If the unit was in contact with the enemy at the time, this may leave the enemy with no one to fight, and unable to impose his will. In the scenario presented earlier, the friendly force could be redeployed within an hour, fully re-supplied, momentarily rested and hydrated, and able to attack the same enemy from a completely different direction. This thought process would

effectively reduce the previously described dilemma of 2nd Battalion by facilitating *both* operational maneuver and unit sustainment.

Forward supplies: Napoleon once said, "It has now become relatively easy to support an army while it is standing still, almost impossible to do so when it was moving forward fast."²⁸ For years, rotary-wing aviation combat units and Marine Wing Support Squadrons (MWSS) have utilized Forward Arming and Refueling Points (FARPs). These FARPs extend the range of aviation assets, enable aircraft increased time-on-station in a given objective area, and significantly decrease the turnaround time required to re-arm and refuel. Maneuvering ground units could further developed and expand this concept to include water, food, batteries, and vehicle parts. In the spirit of OMFTS, a BSSG with increased tactical mobility would be more responsive, flexible, and survivable. It should consider the maneuver of supplies through the undefended littorals, maximizing the use of shorter interior lines relative to the faster moving combat force. This creates two benefits. First of all, it would prevent the slow moving turtle (CSS) from trying to catch the fast hare (combat forces) from behind, thus simplifying the time-distance challenge. Second, and most importantly, it would reduce the burden and reliance on airborne resupply.

Equipment: Continued development of future technologies and equipment will prove fruitful. During the course of this research, three ideas were discovered with the *potential* to positively enhance OMFTS at the operational level by reducing its dependence on aviation for logistical support; therefore decreasing the number of required sorties. First, the concept of using an unmanned aerial vehicle (UAV) for resupply was examined inconjunction with the last Advanced Warfighting Experiment (AWE) "Urban Warrior." This particular experiment utilized a Kaman K-MAX helicopter as a surrogate for a UAV, which simulated Broad-Area

Unmanned Responsive Resupply Operations (BURRO).²⁹ A UAV capable of resupply operations would help mitigate the previously identified concerns limiting manned vertical-lift resupply operations—weather, threat, and aircraft availability. Ideally, a programmable UAV could fly day or night, in weather with low ceilings/visibility to a programmed location, and receive terminal guidance from the ground unit in need of supplies. Second, the use of a Guided Parafoil Air Delivery System-Light (GPADS-L) deserves serious consideration. Essentially a precision guided air-delivery parachute, this system can be dropped from an aircraft at high altitude. Using an onboard guidance and global positioning system, the GPADS-L follows a programmable path to accurately deliver critical supplies. “Experiments with this system during Hunter Warrior demonstrated that this technology offers immediate benefits to the Fleet Marine Force...”³⁰ Thirdly, sea-based sustainment of dispersed units will assuredly depend on heavy-lift helicopters. Current external load carrying systems only permit the suspension of a single load to be carried at a time. This limitation restricts the airframe to delivering one load to one location per sortie. Development of a cargo management system, similar to “Skyhook,” would allow a single helicopter to carry three separate 9,000-pound loads and deliver them to three separate locations, reducing the overall number of sorties required.³¹ This capability would dramatically increase the speed and efficiency of large-scale sustainment operations, like those envisioned to support OMFTS.

SUMMARY

The concepts of OMFTS and STOM create a multitude of space-time-force challenges for future CINCs and Joint Force Commanders. "Since the beginning of the twentieth century the whole idea of distance has changed. This alteration in spatial values came about in little more than a single generation. But rapid though it was, it has become so much a part of our mental habit that we are inclined to forget how revolutionary its effects have been."³² OMFTS and STOM appear to offer great strategic, operational, and tactical flexibility, but they depend on "an expeditionary force...capable of being sustained indefinitely, even in an austere environment devoid of host nation support or complex local infrastructure."³³ The further and quicker combat units are required to operate in an enemy's territory, the greater the reliance will be for aviation to support both the maneuver *and* sustainment of these forces. OMFTS and STOM can very realistically over-extend itself and create unsupportable sustainment challenges for maneuvering combat forces at extended ranges. To avoid another Dien Bien Phu, the Marine Corps must complement its maneuver and sustainment capability through the blending of new ideas, aviation and ground FARPs, and other technologies to reduce the enormously critical—and potentially incurable—dependence on aviation for both maneuver and sustainment.

The historical successes of MAGTF's can be attributed to the integration of its air and ground components. History has proven a complete reliance on "air-bridges" to be precarious and extremely risky. Future MAGTF's must not jeopardize the survival of its ground component by confusing the positive benefits of integration and coordination, with an absolute and unconditional over-dependence on aviation.

NOTES

-
- ¹ William J. Clinton, National Security Strategy for a New Century, (Washington, DC: 1999) 11.
- ² Thomas G. Mahnken, "A Corps for Tomorrow," Marine Corps Gazette, (November 2000): 37.
- ³ Joint Vision 2020, "America's Military: Preparing for Tomorrow," Joint Military Operations Department (NWC Reprint) (Newport, RI: Naval War College 2000) 1, 36.
- ⁴ U.S. Marine Corps, Warfighting Concepts for the 21st Century (Concepts Division (C4I)) (MCCDC, Quantico, VA 1996), I-3.
- ⁵ Julian Thompson, The Lifeblood Of War: Logistics in Armed Conflict (Brassey Publishing Co. (UK) 1991) 196.
- ⁶ Anthony Beevor, Stalingrad (Viking Press, New York, NY 1998) 270, 280, 291-292.
- ⁷ Albert Seaton, The Russo-German War 1941-1945 (Presidio Press, Novato, CA 1971) 333.
- ⁸ Thompson, 164.
- ⁹ Howard R. Simpson, Dien Bien Phu: The Epic Battle America Forgot (Washington, DC: Brassey's Inc. 1994) 96.
- ¹⁰ Appendix B provides further amplification of this notional MEB's table of organization.
- ¹¹ MAWTS-1 Working Group, "A Marine Expeditionary Brigade in 2010," 5 May 2000, MAWTS-1 OMFTS Study, MCAS Yuma, AZ: May 2000. Distances to objectives are consistent with this study and referenced for load computations and simple time/distance calculations.
- ¹² Charles C. Krulak, "Aviation is Fundamental," Marine Corps Gazette (May 1996): 23.
- ¹³ U.S. Department of the Army, Tactics and Techniques for Combined Arms Heavy Forces, FM 71-123 (Washington, DC: 30 September 1992), A-4.
- ¹⁴ U.S. Department of the Navy, Multi-Service Helicopter Sling Load: Basic Operations and Equipment, NWP 3-04.11 (Washington, DC: 10 April 1997), 1-1. This manual prescribes the recommended airspeeds and flight characteristics of all approved air-transportable equipment.
- ¹⁵ MAWTS-1 Working Group. Tables used to determine load computations and simple time/distance calculations have been included in Appendix C for reference, sourced from this study.
- ¹⁶ Ibid.
- ¹⁷ Marine Corps Warfighting Laboratory, Exploiting Hunter Warrior (Quantico, VA: 1997) 25.
- ¹⁸ U.S. Marine Corps, I-18.
- ¹⁹ MAWTS-1 Working Group.
- ²⁰ Ibid.

²¹ Ibid.

²² Mark W. Beddoes, "Logistical Implications of Operational Maneuver from the Sea," Naval War College Review, L, no. 4, seq. 360 (1997): 44. This chart was sourced from this article and uses the formula ($E=np_s$), where n is the number of sorties flown and p_s is the probability of shoot down based on distance flown.

²³ U.S. Marine Corps, I-10.

²⁴ Chet Helms, "Operational Factors," Joint Military Operations Department (NWC 4092A) (Newport, RI: Naval War College 2000) 1.

²⁵ George Thorpe, Pure Logistics: The Science of War Preparation, (Kansas City, MO: Franklin Hudson Publishing Co. 1917) 95.

²⁶ Beddoes, 47.

²⁷ Kenneth Brown, Strategics, The Logistics-Strategy Link, (Washington, DC: National Defense University Press 1987) 57.

²⁸ Martin Van Creveld, Supplying War: Logistics From Wallenstein to Patton, (Cambridge: Cambridge University Press 1982) 233.

²⁹ Scott R. Gourley, "US Marines Experiment With Sea-Based Logistics," Jane's Navy International, 104, no. 5 (1999): 9.

³⁰ Marine Corps Warfighting Laboratory, 42.

³¹ Ibid, 41.

³² Marc Bloch, Strange Defeat: A Statement of Evidence Written in 1940, (Octagon Books, Inc. 1968) 37.

³³ James L. Jones, "What's In A Word? Expeditionary Means More Than Just Getting There Quickly," Armed Forces Journal International, (October 2000): 61.

BIBLIOGRAPHY

- Beddoes, Mark W. "Logistical Implications of Operational Maneuver from the Sea." Naval War College Review, L, no. 4, seq. 360 (1997).
- Beevor, Anthony. Stalingrad. New York: Viking Press, 1998.
- Bell, Billy C. "Marine Aviation and Operational Maneuver From The Sea." Unpublished Research Paper, U.S. Naval War College, Newport, RI: 1997.
- Bloch, Marc. Strange Defeat: A Statement of Evidence Written in 1940. Octagon Books, Inc., 1968.
- Brown, Kenneth. Strategics, The Logistics-Strategy Link. Washington, DC: National Defense University Press, 1987.
- Clinton, William J. National Security Strategy for a New Century. Washington, DC: 1999.
- Gourley, Scott R. "US Marines Experiment With Sea-Based Logistics." Jane's Navy International, 104, no. 5 (1999).
- Helms, Chet. "Operational Factors." Joint Military Operations Department (NWC 4092A). Newport, RI: 2000.
- Joint Vision 2020, "America's Military: Preparing for Tomorrow." Joint Military Operations Department (NWC Reprint). Newport, RI: Naval War College 2000.
- Jones, James L. "What's In A Word? Expeditionary Means More Than Just Getting There Quickly." Armed Forces Journal International. (October 2000): 60-63.
- Krulak, Charles C. "Aviation is Fundamental." Marine Corps Gazette. (May 1996): 22-23.
- Mahnken, Thomas G. "A Corps for Tomorrow." Marine Corps Gazette, (November 2000): 37-39.
- Malavet, Joaquin F. "Operational Maneuver From The Sea (OMFTS): Securing Operational/Strategic Objectives or Dien Bien Phu Revisited." Unpublished Research Paper, U.S. Naval War College, Newport, RI: 2000.
- Marine Corps Warfighting Laboratory. Exploiting Hunter Warrior. Quantico, VA: 1997.
- MAWTS-1 Working Group, "A Marine Expeditionary Brigade in 2010." MAWTS-1 OMFTS Study. Yuma, AZ: 2000.

- Seaton, Albert. The Russo-German War 1941-1945. Novato, CA: Presidio Press, 1971.
- Simpson, Howard R. Dien Bien Phu: The Epic Battle America Forgot. Washington, DC: Brassey's Inc., 1994.
- Thompson, Julian. The Lifeblood Of War: Logistics in Armed Conflict. UK: Brassey Publishing Co., 1991.
- Thorpe, George. Pure Logistics: The Science of War Preparation. (Kansas City, MO: Franklin Hudson Publishing Co., 1917.
- U.S. Department of the Army. Tactics and Techniques for Combined Arms Heavy Forces. FM 71-123. Washington, DC: 30 September 1992.
- U.S. Department of the Navy. Multi-Service Helicopter Sling Load: Basic Operations and Equipment. NWP 3-04.11. Washington, DC: 10 April 1997.
- U.S. Department of the Navy. Ship-To-Shore Movement. NWP 3-02.1. Washington, DC: August 1993.
- U.S. Marine Corps, Warfighting Concepts for the 21st Century. Quantico, VA 1996.
- Van Creveld, Martin. Supplying War: Logistics From Wallenstein to Patton. Cambridge: Cambridge University Press, 1982.

Appendix A



Appendix B

MARINE EXPEDITIONARY BRIGADE

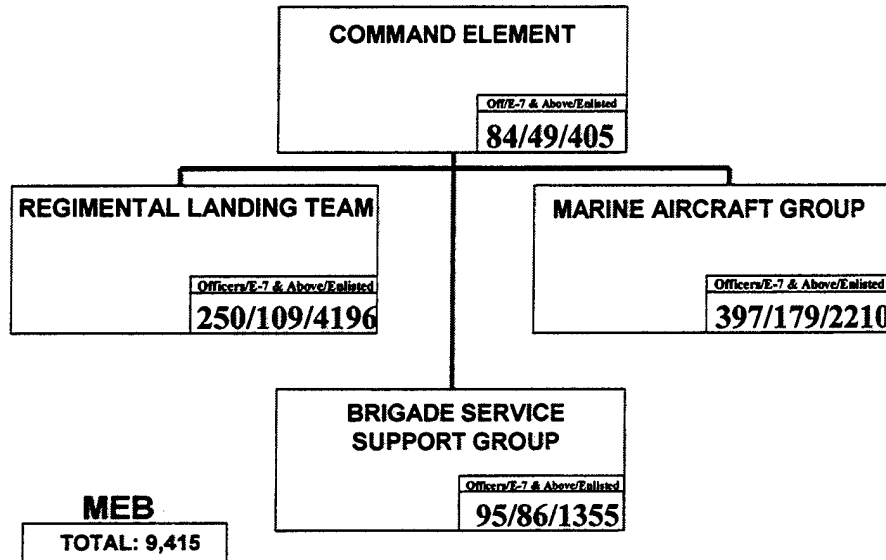

Note:

1. The substantial amount of documentation required to fully articulate the size and composition of an amphibious MEB would be prohibitive to include in this paper. Instead, a sampling of the main elements is provided to support and exemplify the scope of the task at hand.

2. These diagrams and tables have been sourced from the MAWTS-1 analysis of a "Marine Expeditionary Brigade in 2010."

GROUND COMBAT ELEMENT

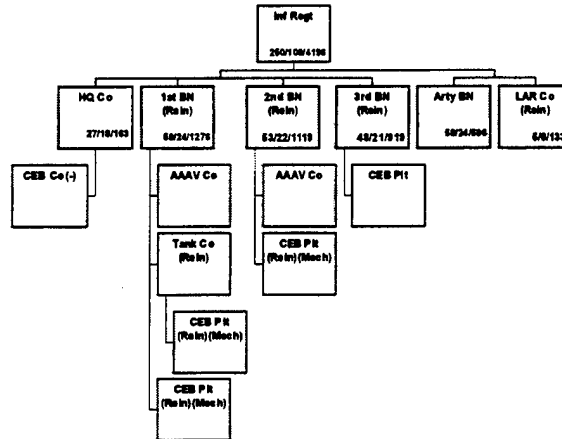

250 OFFICERS 109 E-7 & ABOVE 4,196 E-6 & BELOW TOTAL: 4,555

BATTALION (REIN) T/O & T/E

UNIT	PAX	EQUIPMENT
H&S CO	308	(16) M998, (2) M1035, (6) M101TRLR, (3) MRC-138, (4) M1043, (5) MRC-145, (1) M116 TRLR, (2) M997, (2) AAAPV, (2) AAAVC, (1) M88, (3) M998, (1) MK 48 W/TRAILER, (2) MTVR, (1) M105 TRLR, (1) M 149 WATERBULL
INFANTRY CO #1 (REIN)	244	(2) M998, (12) AAAPV
INFANTRY CO #2 (REIN)	235	(2) M998, (12) AAAPV
INFANTRY CO #3 (REIN)	282	(2) M998, (12) AAAPV, (4) AAAPV, (4) MK 154, (4) M9 ACE, (1) SEE TRACTOR, (1) M101 TRLR, (1) MTVR, (4) M998, (1) M817 DUMP TRUCK
WPNS CO(-) (REIN)	143	(10) M998, (7) M1043, (8) M1045, (3) AAAPV
TANK CO (REIN)	153	(14) M1A1, (2) M88, (2) M998, (2) M116, (1) MRC-145, (1) M997, (2) MTVR, (1) M105 TRLR, (1) WATERBULL, (1) LVS TANDEM W2 M 14 TRLR, (8) M1045, (4) AAAPV, (4) MK 154, (4) M9 ACE, (1) SEE TRACTOR, (1) M101 TRLR, (1) MTVR, (4) M998, (1) M817 DUMP TRUCK
TOTAL	1365	

AVIATION COMBAT ELEMENT

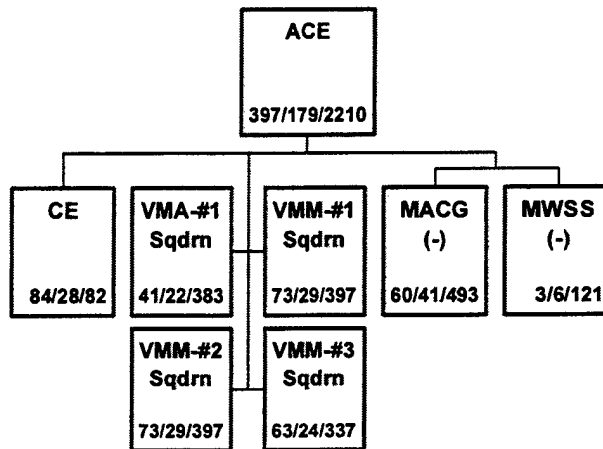

397 OFFICERS 179 E-7 & ABOVE 2210 E-6 & BELOW TOTAL: 2,786 PAX

VMM (REIN) T/O & T/E

UNIT	PAX	EQUIPMENT
VMM SQDRN	32/13/114	(12) MV-22
VMM MALS DET	0/0/35	
HMH DET	20/9/96	(8) CH-53
HMH MALS DET	0/0/36	
HMLA DET	20/6/86	(6) AH-1Z, (3) UH-1Y
HMLA MALS DET	0/1/27	
NAVY MED	1/0/3	
TOTAL	73/29/397	

BRIGADE SERVICE SUPPORT GROUP (BSSG)

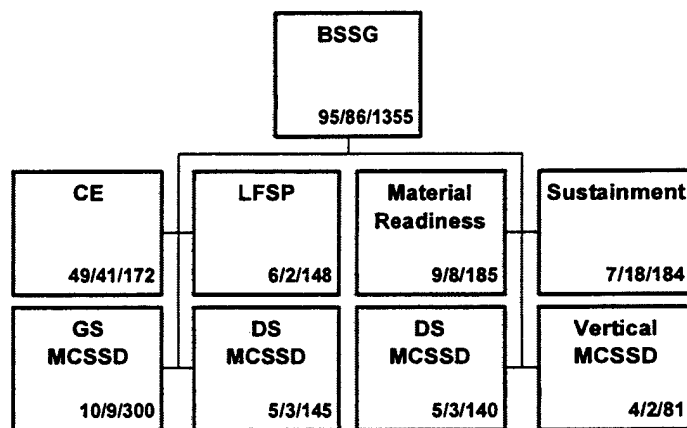

95 OFFICERS 86 E-7 & ABOVE 1,355 E-6 & BELOW TOTAL: 1,536 PAX

GS MCSSD T/O & T/E

UNIT	PAX	EQUIPMENT
HQ LNO/SHOCK TRAUMA SECURITY	7/3/47	(1) MRC-45 [LNO TEAM]; (2) MTVR:105 TRAILER &WB, (1) M998 W/MEPP-16 TRAILER, AMAL 631 &632; [SHOCK TRAUMA PLT]; (8) M998 HARDBACKS [SECURITY]
OPS	1/1/9	(1) MRC-145, (3) M998
IM	0/1/24	(1)MRC-142, (2) MRC-138, (1) MRC-145
DISTRIB MHE/HSTRATIONS EOD/NBC/AMMO	2/3/159	(4) VRC-88/89, (12) MK-14 W/ TRAILERS, (2) MK-15, (2) MK-17, (15) MTVR, (8) 105, (4) WB, (3) TRAMS, (6) RT 4K [DS DISTRIB], (2) 7.5 TON CRANES, (1) M870, (1) MRC-145, (3) M998
MAT READINESS	0/1/31	(1) M936 WRECKER, (1) CONTACT TRUCK, (3) ME998, (1) M88A2 HERCULES
BULK LIQUIDS	0/0/30	(1) M970 R/FLR, (40) FUEL SIXC, (1) MTVR W/105, (20) WATER SIXC, (5) MEP-3, (2) MEP-2, (1) MEP-6
TOTAL	10/9/300	

Appendix C

VERTICAL LIFT						
AIRCRAFT	BEST RANGE AIRSPEED	SPEED W/ EXTERNAL	RANGE COMBAT RADIUS	# MARINES EMBARKED	EXT LIFT CAPACITY	AIRCRAFT WEAPONS
MV-22	230 KTS	120 KTS	345 NM	24	10,000 LBS	None
CH-53E	135 KTS	120 KTS	260 NM	36	36,000 LBS	(2) XM-218

Notes:

1. The following tables were modified from originals created by the working group at MAWTS-1. This basic information can be derived from applicable aircraft NATOPS manuals and doctrinal publications.

2. The speeds of an aircraft transporting an external load are limited by the flight characteristics of the actual load being carried, not necessarily aircraft performance.

Ground Combat Element					
END ITEMS	HWY SPEED (Sustained)	X-CTRY SPEED (Sustained)	RANGE (OFF/ON ROAD)	TROOP CARRYING CAPACITY	WATER SPEED
AAV7A1	30 MPH	20 MPH	LAND RANGE 300 STATUTE MILES; FROM 25 NM OFFSHORE; 42 STATUTE MILES	21	6 KTS
AAAV (2010)	42 MPH	30 MPH	LAND RANGE: 410 STATUTE MILES; FROM 25 NM OFFSHORE; 250 STATUTE MILES	17	20-25 KTS

GROUND MOBILITY / COMBAT SERVICE SUPPORT

END ITEMS	HWY SPEED	X-CTY SPEED	RANGE (OFF / ON ROAD)	TROOP CARRYING CAPACITY	LOAD CAPACITY (OFF / ON ROAD)	TOW CAPACITY	CURB WT
900 SERIES 5T-TRUCK	54 MPH	15 MPH	250 M 350 M	14-20	5 TONS 10 TONS	7.5 TONS	21,740 LBS
MTVR 7T-TRUCK (2010)	55 MPH	30 MPH	390 M 530 M	14-20	7.1 TONS 15 TONS	11 TONS	27,500 LBS

NAVAL LANDING CRAFT

LANDING CRAFT	SPEED	LOAD CAPACITY	RANGE	VEHICLE STOWAGE
LCU	12-15 KTS	160 SHORT TONS	1,000 NM OR 10 DAYS INDEP STEAM	2,180 SQ FT
LCU (X) (2010)	20-25 KTS	225 SHORT TONS	1,000 NM OR 10 DAYS INDEP STEAM	2,180 SQ FT (MINIMUM)
LCAC	17 KTS	60 TONS	200 NM	1,800 SQ FT
LCAC (SLEP) (2010)	35 KTS	70 TONS	200 NM	1,800 SQ FT