

AL/CF-TP-1994- 0019



**COAST GUARD APPROACH TO DEVELOP IMPROVED
PERSONAL FLOTATION DEVICES**

Bert Macesker

**US COAST GUARD RESEARCH AND DEVELOPMENT CENTER
1082 SHENNECOSSETT ROAD
GROTON CT 06340-6096**

Richard P. White, Jr.

**SYSTEMS RESEARCH LABORATORIES, INC.
2800 INDIAN RIPPLE RD.
DAYTON OH 45440**

NOVEMBER 1992

FINAL REPORT FOR THE PERIOD MAY 1992 - NOVEMBER 1992

Approved for public release; distribution is unlimited

20010516 048

**AIR FORCE MATERIEL COMMAND
WRIGHT-PATTERSON AIR FORCE BASE, OHIO 45433-6573**

**A
R
M
S
T
R
O
N
G

L
A
B
O
R
A
T
O
R
Y**

NOTICE

When US Government drawings, specifications, or other data are used for any purpose other than a definitely related Government procurement operation, the Government thereby incurs no responsibility nor any obligation whatsoever, and the fact that the Government may have formulated, furnished, or in any way supplied the said drawings, specifications, or other data, is not to be regarded by implication or otherwise, as in any manner, licensing the holder or any other person or corporation, or conveying any rights or permission to manufacture, use or sell any patented invention that may in any way be related thereto.

Please do not request copies of this report from the Armstrong Laboratory. Additional copies may be purchased from:

National Technical Information Service
5285 Port Royal Road
Springfield VA 22161

Federal Government agencies and their contractors registered with Defense Technical Information Center should direct requests for copies of this report to:

Defense Technical Information Center
Cameron Station
Alexandria VA 22314

TECHNICAL REVIEW AND APPROVAL

AL/CF-TP-1994- 0019

This report has been reviewed by the Office of Public Affairs (PA) and is releasable to the National Technical Information Service (NTIS). At NTIS, it will be available to the general public, including foreign nations.

This technical report has been reviewed and is approved for publication.

FOR THE COMMANDER



THOMAS J. MOORE, Chief
Biodynamics and Biocommunications Division
Crew Systems Directorate
Armstrong Laboratory

REPORT DOCUMENTATION PAGE

Form Approved
OMB No. 0704-0188

Public reporting burden for this collection of information is estimated to average 1 hour per response, including the time for reviewing instructions, searching existing data sources, gathering and maintaining the data needed, and completing and reviewing the collection of information. Send comments regarding this burden estimate or any other aspect of this collection of information, including suggestions for reducing this burden, to Washington Headquarters Services, Directorate for Information Operations and Reports, 1215 Jefferson Davis Highway, Suite 1204, Arlington, VA 22202-4302, and to the Office of Management and Budget, Paperwork Reduction Project (0704-0188), Washington, DC 20503.

1. AGENCY USE ONLY (Leave blank)		2. REPORT DATE November 1992	3. REPORT TYPE AND DATES COVERED Final - 5 May 1992 - 4 November 1992	
4. TITLE AND SUBTITLE Coast Guard Approach to Develop Improved Personal Flotation Devices			5. FUNDING NUMBERS C - F33615-89-C-0574 PE - 62202F PR - 7231 TA - 36 WU - AZ	
6. AUTHOR(S) Bert Macesker Richard P. White, Jr.				
7. PERFORMING ORGANIZATION NAME(S) AND ADDRESS(ES) US Coast Guard Research and Development Center 1082 Shennecossett Road Groton CT 06340-6096			8. PERFORMING ORGANIZATION REPORT NUMBER	
9. SPONSORING / MONITORING AGENCY NAME(S) AND ADDRESS(ES) Armstrong Laboratory, Crew Systems Directorate Biodynamics and Biocommunications Division Human Systems Center Air Force Materiel Command Wright-Patterson AFB OH 45433-7901			10. SPONSORING / MONITORING AGENCY REPORT NUMBER AL/CF-TP-1994-0019	
11. SUPPLEMENTARY NOTES This article has been published in the 1992 SAFE Symposium Proceedings.				
12a. DISTRIBUTION / AVAILABILITY STATEMENT Approved for public release; distribution is unlimited			12b. DISTRIBUTION CODE	
13. ABSTRACT (Maximum 200 words) The US Coast Guard has been sponsoring personal flotation device (PFD) related research since the early 1970s. These studies have generally been limited to static calm water flotation evaluations. The US Coast Guard approval process requires a human subject to enter calm water wearing a candidate PFD. The subject simulates unconsciousness and the PFD is evaluated for flotation and righting ability. The calm water method of testing has been a safe and repeatable method for determining the gross in-water characteristics of an attached PFD. However, calm water testing practices can not address the effects of wave action on life jackets, the optimum angle of repose and head angle relative to a wave front, the number of mouth immersions, and buoyancy requirements in waves. In response to the need to better understand these dynamic effects, an adaptation of the Air Force Articulated Total Body (ATB) is being developed to simulate human behavior in waves. To support the development of this capability, a sophisticated instrumented flotation manikin is being constructed that will serve as a full scale validation tool for the modified ATB simulator and general research tool for Coast Guard survival system studies. This paper provides an overview of the Coast Guard's rough water performance of PFDs research program and detailed description of the instrumented manikin under construction.				
14. SUBJECT TERMS manikin, personal flotation device, boating, safety, water forces, modeling			15. NUMBER OF PAGES 15	
			16. PRICE CODE	
17. SECURITY CLASSIFICATION OF REPORT UNCLASSIFIED	18. SECURITY CLASSIFICATION OF THIS PAGE UNCLASSIFIED	19. SECURITY CLASSIFICATION OF ABSTRACT UNCLASSIFIED	20. LIMITATION OF ABSTRACT UL	

This page intentionally left blank.

Coast Guard Approach to Develop Improved Personal Flotation Devices

Bert Macesker
U.S. Coast Guard R&D Center
1082 Shennecossett Road
Groton, CT 06340-6096

Richard P. White, Jr.
Head - Research & Experimental Simulation
Glenn L. Thomas
Lead Designer
Systems Research Laboratories, Inc.
2800 Indian Ripple Road
Dayton, OH 45440-3696

ABSTRACT *The U.S. Coast Guard has been sponsoring personal flotation device (PFD) related research since the early 1970s. These studies have generally been limited to static calm water flotation evaluations. The U.S. Coast Guard approval process requires a human subject to enter calm water wearing a candidate PFD. The subject simulates unconsciousness and the PFD is evaluated for flotation and righting ability. The calm water method of testing has been a safe and repeatable method for determining the gross in-water characteristics of an attached PFD. However, calm water testing practices can not address the effects of wave action on life jackets, the optimum angle of repose and head angle relative to a wave front, the number of mouth immersions, and buoyancy requirements in waves. In response to the need to better understand these dynamic effects, an adaptation of the Air Force Articulated Total Body (ATB) is being developed to simulate human behavior in waves. To support the development of this capability, a sophisticated instrumented flotation manikin is being constructed that will serve as a full scale validation tool for the modified ATB simulator and general research tool for Coast Guard survival system studies. This paper will provide an overview of the Coast Guard's rough water performance of PFDs research program and detailed description of the instrumented manikin under construction.*

INTRODUCTION

The importance of PFD research cannot be underestimated. Although the general trend has been a reduction in recreational boating fatalities over the past 20 years, there remains a significant

number of boating fatalities as shown in Figures 1 and 2. Two of the primary factors influencing this reduction are improved public education and more comfortable PFDs. Apparently, there has been an increase of 59 recreational boating fatalities from 1990 to 1991. This increase could be due to a number of different factors or combinations of factors such as the warmer than usual winter which lengthened the boating season or perhaps better reporting procedures. It would be difficult to draw a quantitative conclusion.

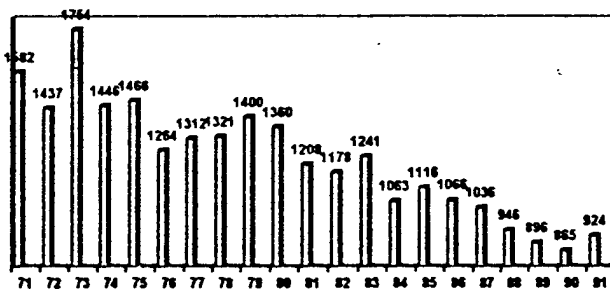

Figure 1. Recreational Boating Fatalities from 1971 to 1991

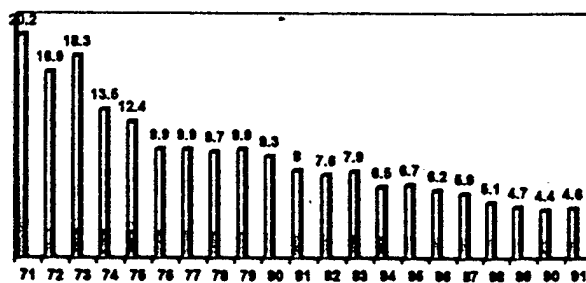

Figure 2. Fatality Rate per 100,000 Boats from 1971 to 1991

The following is an account of a recent recreational boating accident which is by no means an isolated one.

About 1800 hours on June 12, 1992, a California registered recreational boat with three adults and five children aboard sank in San Pablo Bay, California. An 18-month-old drowned; two 7-year-old males, a 2-year-old male, and a 29-year-old male drowned and one adult male passenger was never recovered. The surviving adult female was interviewed. "We were going out under the Richmond Bridge, it was nice weather, it wasn't windy or nothing, like there was a little wind but it wasn't strong or nothing...we stopped at the island for about 20 minutes to half an hour we stayed there and let the kids play and it started to get windy so we said we better go back and it was getting late so on the way back it got really windy and the waves were pretty high you knew they were high to where they were coming in the boat." The boat subsequently took on water and quickly sank. "I gave, my oldest was hanging on he was hanging on to me he seemed to be OK I just told him don't panic and he would be alright, don't let the water get in your mouth and you'll be alright...I don't know how long before I had to let them go because I didn't want to let them go so I had to hold all three of them because my oldest one he went into shock...holding on to three kids and trying to keep afloat myself and I had my life jacket under my arm at the time so I was finding myself going under." The children's bodies were found with life preservers attached. [NTSB Survival Factors Findings Report (Ref 1)].

CALM WATER PRACTICES

The usage of the term PFDs needs to be qualified before proceeding. PFDs generally encompass several types of flotation aids from Type I to Type V. Figure 3 illustrates some typical PFDs from Type I to Type IV (Type V not shown). Type I has the greatest buoyancy and is the most effective in rough water. The Type II turning action is slower than the Type I but is more comfortable to the wearer. Type III is not designed to turn the wearer face up but can be the most comfortable. The Type IV includes throwable devices that are grasped and held onto by the user or thrown to a person who has fallen overboard. A Type V PFD is approved for restricted uses such as board sailing but may not be suitable for other recreational boating activities (not shown). The term PFD will, for the purposes of this paper,

refer to those PFDs that can be donned as a life jacket.

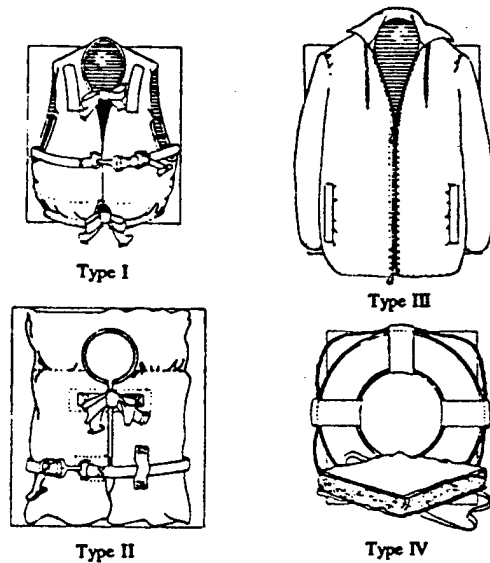

Figure 3. Typical Type I through Type IV PFDs

The U.S. Coast Guard has been sponsoring PFD research since the early 1970s. This research has generally been limited to static calm water flotation evaluations. The underlying reason for the universal acceptance of calm water testing, approval testing of new products as well as research studies, is that it has evolved into a safe repeatable method for determining the gross in-water characteristics of a PFD. Using human test subjects for anything but calm water would result in increased risk to the subject and involuntary subject activity which could invalidate the tests. The lack of an available standard has also limited approval and research to calm water.

The U.S. Coast Guard approval process requires a human subject to enter calm water wearing the candidate PFD. The subject simulates unconsciousness and the PFD is evaluated for flotation and righting ability. The U.S. Coast Guard has both structural and performance standards and procedures for approval of PFDs. For example, excerpts from the U.S. Code of Federal Regulations (Title 46 Subpart 160.176 for Inflatable Lifejackets) stipulate the following average requirements for the approval of PFDs:

"2 (ii) Each subject then takes three gentle breast strokes and while still face-down in the water, relaxes completely while exhaling to functional residual capacity. The time

from the last breast stroke until breathing is not impaired is recorded. This average time must not exceed 5 seconds."

"4 (i) The average freeboard prior to positioning the head for maximum freeboard must be at least 120 mm;

(ii) The average torso angle must be between 30° and 50° (back of vertical); and

(iii) The average face-plane angle must be between 20° and 50° (back of vertical)."

"(5) 'HELP' Position. Starting in a relaxed, face-up position of static balance, each subject brings the legs and arms in towards the body so as to attain the 'HELP' position (a fetal position, but holding the head back). The life jacket must not turn the subject face down in the water."

There is also a jump test requirement where the subject dons a lifejacket and jumps into the water from a height of 4.5 m. The life jacket must inflate automatically and sufficiently float the body so that the mouth is out of the water.

The International Maritime Organizations' Resolution A.689(17), adopted on 6 November 1991, provides similar performance requirements regarding testing of PFDs. The requirements for righting and drop tests stipulate the following:

"2.9.5 The test subject should swim at least three gentle strokes (breast stroke) and then with minimum headway relax, with the head down and the lungs partially filled, simulating a state of utter exhaustion. The period of time should be recorded starting from the completion of the last stroke until the mouth of the test subject comes clear of the water. The above test should be repeated after the test subject has exhaled. The time should again be ascertained as above. The freeboard from the water surface to the mouth should be recorded with the test subject at rest."

"2.9.6 Without readjusting the lifejacket, the test subject should jump vertically into the water, feet first, from a height of at least 4.5 m. When jumping into the water, the test subject should be allowed to hold on to the lifejacket during water entry to avoid possible injury. The freeboard to the mouth

should be recorded after the test subject comes to rest."

"2.9.7 After each of the water tests described above, the test subject should come to rest with the mouth clear of the water by at least 120 mm. The average of all the subjects' trunk angles should be at least 30° back of the vertical, and each individual subject's angle should be at least 20° back of vertical. The average of all subjects' face plane (head) angles should be at least 40° above the horizontal, and each individual subject's angle should be at least 30° above horizontal. In the righting test, the mouth should be clear of the water in not more than 5s. The lifejacket should not become dislodged or cause harm to the test subject."

These approval practices are by nature somewhat of a subjective performance appraisal of PFDs. However, this static measure (using calm water only) may not adequately evaluate a PFD's performance in rough water.

PFD RELATED FATALITIES

A query made last year of the recreational boating accident statistics database (Ref 2) revealed 135 drowning deaths in choppy, rough, and very rough waters from 1988 to 1990. All of these bodies were found with PFDs attached. It is possible that some of these deaths may be related to inadequate PFD design in rough water. Unfortunately, there is little statistical data to correlate drowning death to the type of PFD used because PFD types have only recently been reported and factored into this database. The present statistics based on limited data of 27 drownings where PFD type was actually reported indicate a general breakdown as follows:

Type I - 0 Fatalities
Type II - 6 Fatalities
Type III - 17 Fatalities
Type IV - 3 Fatalities
Type V - 1 Fatality

This breakdown could be projected onto the figure of 135 drowning deaths. However, caution needs to be employed before making too many inferences. Although zero fatalities are associated with the Type I PFD, it is not known whether this is attributable to persons not wearing them or lack

of boating accidents where Type Is were kept onboard. The 1991 recreational boating accident statistics indicate that out of the 924 fatalities the majority of fatalities occurred in calm waters, generally in lakes, ponds, rivers and streams as illustrated in Figures 4 and 5.

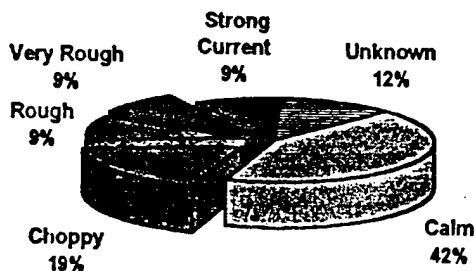

Figure 4. Distribution of Recreational Boating Fatalities for 1991 as a Function of Water Conditions

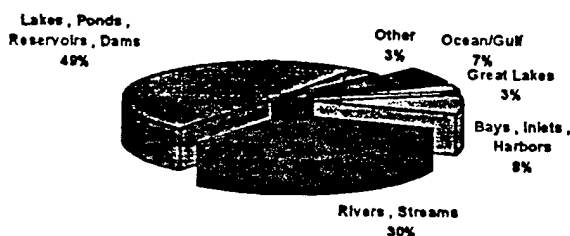

Figure 5. Distribution of Recreational Boating Fatalities for 1991 as a Function of Body of Water

Even though there are no hard-core statistics pointing to the need for better PFD performance in rough water, it is more than just intuitive that a better understanding of the impact of rough water on human survival and how this can be included in performance appraisals of PFDs is needed. Therefore, the U.S. Coast Guard is sponsoring the development of a capability for conducting human and PFD rough water interaction studies. This will consist of an adaptation of a computer program used by the Air Force for simulations of aircrew responses to aircraft ejection and wind blast forces. The U.S. Coast Guard is also collaborating with the Canadian Coast Guard in the development of an instrumented flotation manikin which will be used to validate this program.

BACKGROUND

PAST ROUGH WATER TESTING

Until as recently as the mid-eighties PFDs have only been tested in calm water. Rough water

testing was conducted in 1983 at David Taylor Research Center (DTRC) with human subjects in a wave making tank in Wehr (1984, Ref 3). These tests provided qualitative information on the effects of different PFDs on persons in rough water. Recommendations were made to evaluate the repeatability of testing PFD designs in rough water by using instrumentation to measure such items as head angle and the number of mouth and nose immersions. Apparently, there are just some questions that calm water methods cannot address such as:

- Effects of wave action on the turning moment of PFDs.
- The position that should be taken by the person wearing a PFD relative to a wave front, i.e., the optimum angle of repose for his body and head angle.
- The number of mouth immersions that can be expected.
- How much buoyancy is adequate in rough water.

In 1988, DTRC, sponsored by the U.S. Coast Guard, attempted to collect quantitative data on factors influencing the performance of PFDs in Hart (1988, Ref 4). Experiments were performed on a 50th percentile male anthropomorphic flotation dummy referred to as "Sierra Sam", and human subjects to evaluate the natural periods of oscillation in calm water. DTRC recommended the acquisition of a set of anthropometric manikins for standardization of testing and the application of the Air Force's human body dynamics simulation program.

Although, a survivor's primary concern in rough water will be his or her maintenance of airway freeboard, a secondary yet important additional concern is hypothermia. The physical activity required to maintain freeboard, distance from the mouth to the water's surface, in rough water will increase heat loss. In 1985, a study was conducted to evaluate the cooling rates of human volunteers wearing Coast Guard operational protective garments in cold sea water under calm versus rough sea conditions in Steinman (1985, Ref 5). The results of this experiment showed significantly faster body cooling rates in rough seas than in calm seas for the subjects wearing a

thermal float coat, aviation anti-exposure coveralls, and boat crew coveralls and significantly higher heart rates in the rough water for all garments tested. The loose fitting protective garments performed the worst because of the wave-induced cold water rushing through the garment.

ATB MODEL BACKGROUND

The Articulated Total Body (ATB) Model was created by adding an aerodynamic force and harness belt capability to the Crash Victim Simulation (CVS) Program used by National Highway Transportation Safety Administration (NHTSA) in Fleck (1975, Ref 6). The ATB Model is used to evaluate the three dimensional dynamic response of a system of rigid bodies when subjected to a dynamic environment. The environment consists of applied forces and interactive contact forces. The ATB Model can be used to model both dynamic human and manikin behavior. The program considers the body as being segmented into individual rigid bodies. Each segment has the characteristic mass of the body between body joints and mass moments-of-inertia. The maximum number of segments that can be modeled is presently limited to 30 but typically 15 segments are considered more than adequate. Segments can be added where deemed necessary for added emphasis in certain parts of the body.

WATER FORCES ANALYSIS CAPABILITY

INVESTIGATORS/SPONSORS

The Water Forces Analysis Capability (WAFAC) model represents an added capability to the ATB model. The WAFAC was developed by the United States Air Force and their contractors for the United States Coast Guard. The Coast Guard R&D Center located in Groton, Connecticut is directing this work for the Survival Systems Branch of the Marine Vessel Inspection (MVI) Division at Coast Guard Headquarters. The Survival Systems Branch establishes the technical and testing requirements for Coast Guard approved equipment. The work on the WAFAC model and modifications to the ATB model were performed by General Engineering and Systems Analysis Company, Inc. (GESAC). The effort was monitored by Dr. Ints Kaleps, Chief of the Vulnerability Assessment Branch of the Armstrong Laboratory (AL/CFBV). The manikin that is now being developed by Systems Research Laboratories, Inc., is based on the form,

dimensional, and mass characteristics of the Hybrid II manikin which is the manikin approved by the National Highway Transportation Safety Administration for testing automotive safety features incorporated in the modern automobile.

Recently, a Joint Research Project Agreement (JRPA) between the Department of Transportation and Transport Canada under the Volpe-Jamieson Agreement was implemented to cooperate and exchange information on survival system research. The Canadians are interested in this area because they have recently identified recurring flotation attitude problems in young children and generally do not want to put test subjects at risk, especially children while testing new products.

MODEL DESCRIPTION

The WAFAC model predicts human body response to water forces corresponding to still water or to wave conditions and can be used to examine the effects on body motion with a PFD attached. The WAFAC model employs linear wave theory to determine the forces on a submerged body. The forces involved include buoyancy, wave excitation effects, added-mass, damping, drag, and lift. Incident waves are defined by the wavelength, wave amplitude, and phase angle. Presently, up to 10 different waves can be linearly superimposed. The model predicts gross body motion as well as individual segment accelerations, velocities, and displacements. Buoyancy, added-mass, drag, lift, and wave forces are calculated in user-defined reference frames.

SUMMARY OF WAFAC THEORY

MODEL INFORMATION

Three items of information are required to describe the motion of a person attached to a PFD floating in waves. The first is a description of both the water surface and water forces acting on the person. The second is a complete description of the person floating in the water. The person must be described by a system of linked segments with an accurate characterization of the properties of the individual segments. These properties include segment contour geometry, segment locations, mass-moment-of-inertia, center of mass, and joint torque definitions. The third item required is an adequate description of the PFD to be attached to the individual for performance evaluation.

GENERAL APPROACH

The solution of freely floating bodies in surface waves is very difficult. The WAFAC model approach is to employ potential flow theory to much of the fluid, i.e., viscous effects are neglected. Newman (1986, Ref 7) states that the maneuvering problem generally involves separation and lifting effects, whereas the motions of bodies in waves are not as significantly affected by viscosity or vorticity.

However, a purely nonviscous treatment would not adequately describe the viscous nature of the local boundary layer. Therefore, the WAFAC model also employs some level of a viscous treatment (drag and lift effects).

Developing a useful model will be an iterative process. It will include an empirical approach where at first coefficient values for damping, added mass, and lift will be assumed for sensitivity studies to be performed by the Air Force followed by the collection of experimental data on individual segments. A full size instrumented manikin is also basic to conducting correlation experiments to fine tune the analytical model.

DESCRIPTION OF WAVE MODEL

The mathematical description of water waves is very complex and any attempts at classifying them is in the form of idealized conditions. In developing a simulation capability, two-dimensional wave motion is adopted. Although a two-dimensional wave can only be approximated in a laboratory environment, it represents a logical starting point in developing a rough water capability. Water wave theories can be generally classified as either "small amplitude" or "long wave" theories. Long wave theory which addresses non-linear breaking waves requires treatment by numerical methods. Wave breaking is a complex phenomenon which can be seen as breakers at a beach or as white caps at sea.

A complete description of wave behavior will involve both its surface form and fluid motion beneath the wave. In the case of a person, that is not self propelled, floating on the surface, the dominant forces will likely be related to the water particle accelerations rather than drag forces. The WAFAC model uses linear wave or small amplitude wave theory as the first approximation to describing wave characteristics. The model assumes that water flow will be incompressible,

inviscid, and irrotational so that the velocity field can be represented as the gradient of a scalar function ϕ or the velocity potential. By this, it is meant that the description of flow is outside the boundary layer where the flow is frictionless. Both the kinematic and dynamic boundary conditions are used to define the free-water surface. These can be combined to yield a single boundary condition for the velocity potential, ϕ . This equation is,

$$\frac{\partial \phi^2}{\partial t^2} - g \frac{\partial \phi}{\partial z} = 0$$

The simplest solution of the free surface condition is the two-dimensional plane sinusoidal progressive wave which can be described by its free-surface elevation, η , with wave amplitude, A , wave number, k , and wave frequency, ω as,

$$\eta(x,y,t) = A \cos[k(x \cos \beta + y \sin \beta) - \omega t + \epsilon]$$

Water depth, h , is defined by either being of finite depth or infinite depth. For a fluid depth that is infinite, i.e., $h \rightarrow \infty$, the velocity potential is given as,

$$\phi = \frac{gA}{w} e^{ky} \sin(kx - \omega t)$$

and for finite depth the velocity potential is,

$$\phi = \frac{gA}{w} \frac{\cosh k(y+h)}{\cosh kh} \sin(kx - \omega t)$$

The WAFAC model permits the used of up to 10 regular waves to describe the free surface. The waves are uniquely defined by their wavelength, amplitude, phase angle, and wave direction.

WATER FORCES DESCRIPTION

The WAFAC model accounts for hydrostatic pressure, wave excitation, added mass, and drag and lift effects when calculating the water forces on the body. Buoyancy effects are due to fluid pressure acting on the body. Wave excitation effects create forces and moments that act on the body. Added mass represents the amount of fluid accelerated with the body. Drag on a sphere moving through the water will be subjected to friction and form drag. This model evaluates the wave excitation forces as a function of depth of the submerged object. Figure 6 illustrates the water forces considered.

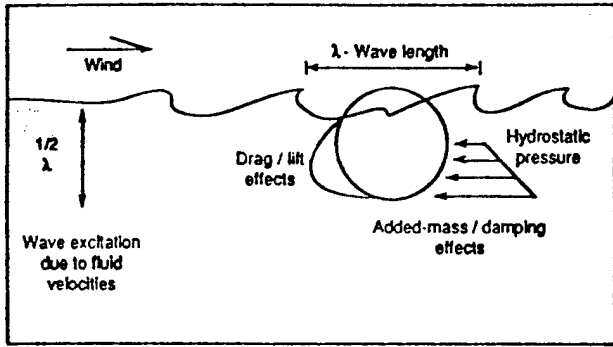

Figure 6. Various Water Forces Affecting a Floating Body

The computation of the total water force acting on a body is derived by Newman (1986) and was the approach adopted by GESAC, Inc. (1991, Ref 8). The total potential is,

$$\Phi(x,y,z,t) = \text{Re}\left\{\left(\sum_{j=1}^6 \xi_j \phi_j(x,y,z) + A\phi_A(x,y,z)\right)e^{i\omega t}\right\}$$

The first term represents the velocity potential of the rigid body motion in the absence of waves and provides the description to the radiation problem. The second potential term represents the interaction of the body with the incident waves and provides the general description of the diffraction problem. This term can be further decomposed into diffraction, ϕ_0 , and scattering, ϕ_7 , effects of the incident wave on a fixed body,

$$\phi_A = \phi_0 + \phi_7$$

$\xi_j, j = 1 - 6$ represent the dependent body motions in heave, pitch, roll, yaw, surge, and sway. The forces and moments acting on a floating body are determined in Newman (1986) by substituting the total potential into Bernoulli's equation,

$$p = -\rho\left(\frac{\partial\phi}{\partial t} + gy\right)$$

and then integrating the fluid pressure over the wetted surface yielding the following expressions;

$$\begin{pmatrix} F \\ M \end{pmatrix} = \rho g \int_{S_B} \begin{pmatrix} n \\ r \times n \end{pmatrix} y ds$$

$$-\rho \text{Re} \sum_{j=1}^6 i\omega \xi_j e^{i\omega t} \int_{S_B} \begin{pmatrix} n \\ r \times n \end{pmatrix} \phi_j dS$$

$$-\rho \text{Re} i\omega A e^{i\omega t} \int_{S_B} \begin{pmatrix} n \\ r \times n \end{pmatrix} \phi_A dS$$

The first integral represents the hydrostatic contribution. The second integral represents added mass and damping contributions, and the last integral is the exciting force or moment proportional to the incident wave amplitude. The velocity potential, ϕ_0 , comes from the potentials for finite and infinite depth described previously.

Additionally, for simulations that require a viscous treatment, GESAC (1991) computes the frictional effects as a drag and lift force. The drag force is computed as,

$$F_D = \frac{1}{2} C_{DA} \rho V_{rel}^2$$

The lift force is computed as,

$$F_L = \frac{1}{2} C_L \sin 2\alpha A_{proj} \rho V_{rel}^2$$

' α ' is the angle between the normal vector n and V_{rel} . C_D and C_L are the drag and lift coefficients, respectively.

DYNAMIC STANDARDS FOR PFD PERFORMANCE

Some specific parameters that may be relevant to assessing human survival in rough water can be derived from this model. They include time histories of the following:

Buoyancy - Buoyancy time histories could indicate sensitivities of the person wearing a PFD to passing wave peaks and wave troughs.

Dynamic Freeboard - Dynamic Freeboard may well be the most significant performance measure. It is defined as the distance from the water surface to the lowest point on the mouth.

Waterplane Area - Waterplane area can be used to determine restoration factors. A damping factor can also be determined from a displacement time history at some anthropometric landmark such as the center of a person's chest.

Body Repose Angles - The body repose angles can provide information on turning times. There are two angles of concern: faceplane angle and trunk angle.

PROGRAM SAMPLE OUTPUT

SPHERE IN REGULAR WAVE

The simulation software can be run with an 80386 processor PC as an executable. The user can define the wave characteristics such as wavelength, height, phase, and the initial starting conditions of the test subject. Simulations can be run with simple geometric shapes. Figure 7 demonstrates the resulting time history of a sphere placed in a sinusoid sea and integrated over a 5 second period. The time history is of freeboard which in the case of the sphere is defined as the distance from its center of mass to the water's surface.

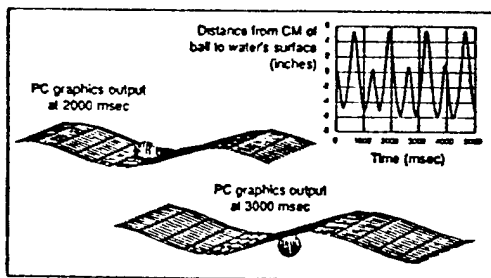

Figure 7. Sample of Water Forces Capability with a Simple Floating Sphere in a Regular Wave

MANIKIN WITH PFD

Figure 8 demonstrates interaction of a manikin (Hybrid III) standard wearing a PFD in two 1-foot amplitude regular waves out of phase. The manikin was initially dropped into the waves. The added mass, drag, and lift coefficients were approximated as 0.3. The PFD was modeled with five ellipsoids.

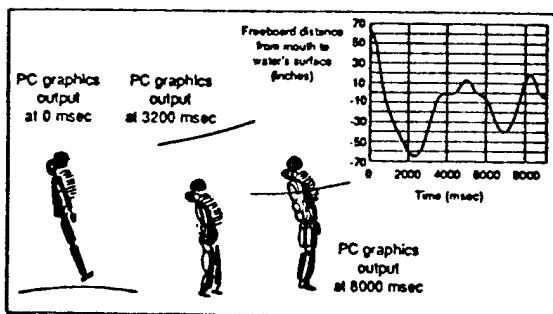

Figure 8. Sample of Water Forces Capability with a Manikin in Two Regular Waves Out of Phase

FUTURE WORK

VALIDATION WITH SIMPLE GEOMETRIC SHAPES

Validation efforts will include tests with several simple geometric shapes similar in size to the ellipsoids used in the ATB model. The different shapes will be tested individually and linked together with pinned joints. Figure 9 illustrates the validation segments linked together. Testing segments linked together is needed in order to study segment blocking effects. Segment blocking effects refer to the literal blocking of water flow by one segment directly in front of another. The discounting of these hydrodynamic blocking effects may cause over estimations of water forces on combined segments. Controlled tests will be performed in a wave tank by placing the objects in the water and giving them various initial displacements and recording their responses on video. The digitized video data will be compared to computer simulations.

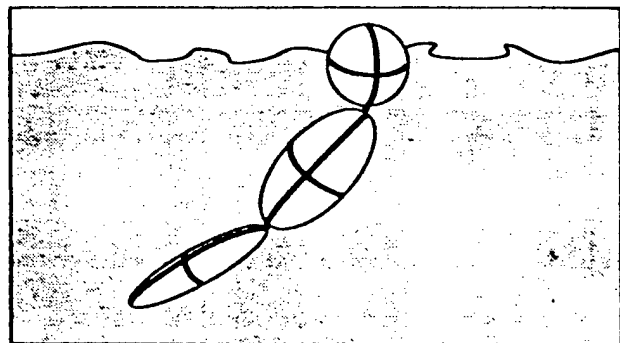

Figure 9. Linked Validation Shapes for Studying Segment Blocking Effects

IMPROVEMENTS TO COMPUTER PROGRAM

Although, the computer model is operational it does require expertise to configure a simulation. Work needs to be done to improve the user interface to make it more accessible to the practical designer of flotation devices. A preprocessor is needed to allow the input of PFD attachment data and wave conditions for sets of standardized initial conditions in a user friendly format. A post-processor is needed to better handle the output time histories and graphics.

INSTRUMENTED MANIKIN

MANIKIN DEVELOPMENT

The development and use of human surrogates (manikins) to test and develop improved PFDs is not a new concept. In 1967 the Sierra Engineering Company, under contract with the FAA Civil Aeromedical Institute, developed an anthropomorphic flotation dummy for evaluating flotation equipment design. A paper describing the manikin and some preliminary results obtained during initial testing was presented at the Seventh Symposium of SAFE in Las Vegas, Nevada, in 1969. A two-view photograph of this manikin is shown in Figure 10. While this manikin had many of the required features to undertake the desired evaluation of PFDs, there were many needed features that were not incorporated. Therefore the design of the manikin that is now being developed is based on the Hybrid II manikin.

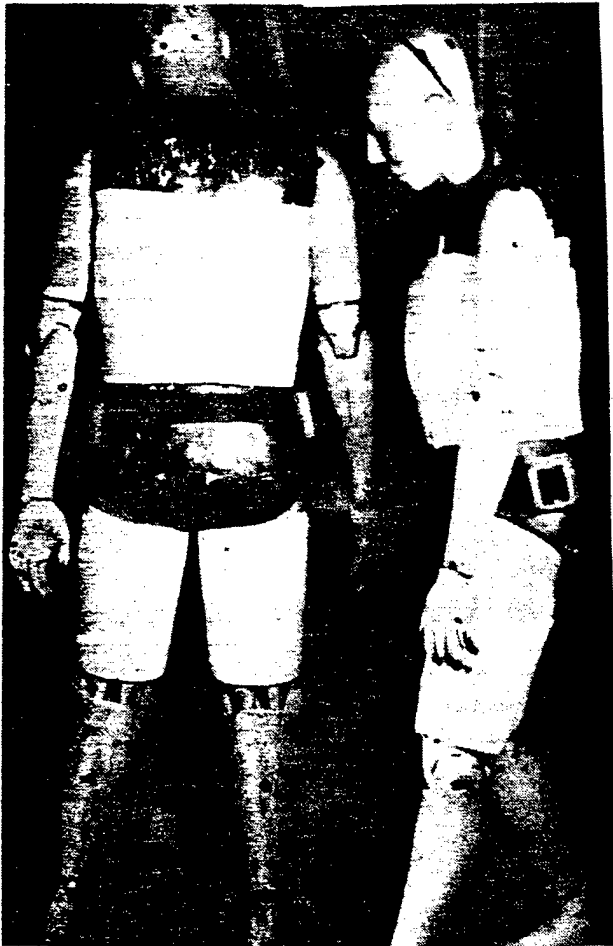

Figure 10. Manikin

Figure 11 is a photograph of the Hybrid II manikin. The Hybrid II manikin is based on the average size male adult and has a stature of 68.3 inches and a weight of 169 pounds. The joint articulations and ranges of motion being incorporated in the new manikin are presented in Table 1. It is believed that these articulations are more than adequate to simulate human motions that are important for evaluating the effectiveness of PFDs in an emergency situation. While the new manikin is based on the Hybrid II dummy, the following special features and changes to the manikin are being incorporated.



Figure 11. Hybrid II Manikin

TABLE 1. Manikin Articulations and Ranges of Motion

Joint	Range of Motion (Degrees)
Shoulder Complex	
Flexion	178
Extension	57
Abduction in Transverse Plane	48
Abduction in Coronal Plane	170
Rotation - Interior	115
- Exterior	15
Elbow	
Flexion	140
Hip	
Flexion	115
Extension	30
Abduction (Transverse and Coronal Plane)	60
Abduction	30
Rotation (Prone and Sitting) - Interior	40
- Exterior	40
Knee	
Flexion (Voluntary)	125
Neck	
Flexion	50
Extension	20
Lateral	±30
Spine Rotations (at Pelvis/Spine Interface)	
Flexion	40
Extension	20
Lateral	±20
Ankle	
Dorsi Flexion	30
Plantar Flexion	50
Wrist	
Flexion	90
Extension	70

- Self contained instrumentation system.
- Controlled buoyancy of each major body segment.
- Control of joint rotational friction.
- Mouth splash detection system.
- Emergency flotation system.

Each of these special features will be discussed separately.

SELF CONTAINED INSTRUMENTATION SYSTEM

The manikin will incorporate 31 instrumentation sensors as follows:

- Twenty-one joint position measurements.
- Three accelerations (Gx, Gy, Gz).
- Three angular position measurements (Qy, Qx, Qz).
- Four pressure taps to determine manikin angle of flotation.

The analog signals from these sensors will be processed and stored in the 32 channel Dynamic Event Recorder (DER) developed by Systems Research Laboratories, Inc. The battery operated DER will sample each analog signal 100 times a second and store over 11 minutes of data.

Through a radio link, the Data Acquisition System (DAS) can be started, stopped, and restarted at the discretion of the operator. The setup and checkout of the DAS is accomplished through a computer link which will be disconnected during a test and the download of stored data is accomplished by reconnecting the computer and transferring the digital data to the computer memory.

Figure 12 presents a sketch of the thorax which shows the location of the DER as well as the accelerometers, angular position measurements, and radio receiver in a sealed, water tight compartment. While all of this equipment is located within the thorax, the biofidelic characteristics of this body component are maintained.

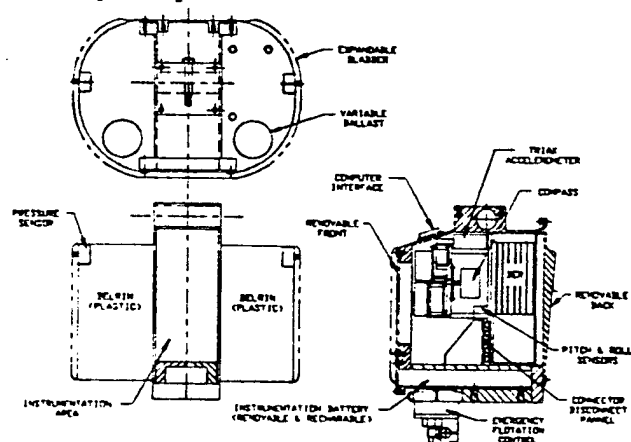

Figure 12. Thorax Mechanical Design

CONTROLLED BUOYANCY OF BODY COMPONENTS

The body density and, thus, the buoyancy in water of each human component (arm, leg, abdomen, chest) are different and different for various humans depending upon the relative fat/muscle content. In order to provide the capability of investigating the effects of this human variability on the effectiveness of a PFD, each major body component except the hands, feet, and head have been designed to allow the buoyancy to be changed. Figure 13 presents a drawing of a forearm illustrating the mechanism by which the buoyancy will be controlled. Pressurized air is inserted into the interior of the

arm which expands the vinyl skin and, thus, increases the volume of the component while maintaining a constant component weight. Approximately, a 20 percent decrease in density of the various body components can be obtained in this manner. The chest or thorax uses a slightly different approach to change its buoyancy characteristics. As noted in Figure 12, a bladder surrounds the viscera. When this is pressurized and expanded, the change in air volume duplicates the 20 percent change (approximate) in the air retained in the lung between an unconscious and a conscious person taking a full breath. While this bladder expansion duplicates the change in the lung capacity, it also simulates the change in thorax volume which is important to the fit of the

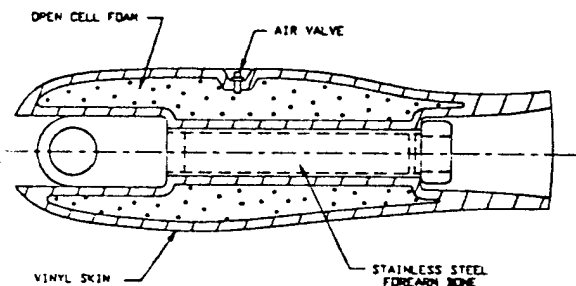

Figure 13. Typical Segment Skin Construction

PFD. In addition, the mean density of the thorax can be altered by adding or removing lead ballast weights located within the thorax. By removing some of the lead ballast weight a "true floater" can be simulated and by adding lead ballast weight a "true sinker" can also be simulated.

CONTROL OF JOINT ROTATIONAL FRICTION

There is a significant difference in the muscular torque generated by a conscious or unconscious person. In order to simulate the passive nature of the muscular torque, a means of simulating this torque has been developed. Figure 14 presents a drawing of the elbow joint illustrating the technique that will be utilized. The friction material is automotive brake lining and the normal pressure is applied by means of a bolt having a fine thread in order to provide a fine control of the resistive joint torque. This same approach was successfully used in the development of the ADAM manikin developed for ejection seat testing (Ref 9). The brake material has been subjected to 3 months of cyclic immersion in water and drying without any notable deterioration in the friction characteristics of the material.

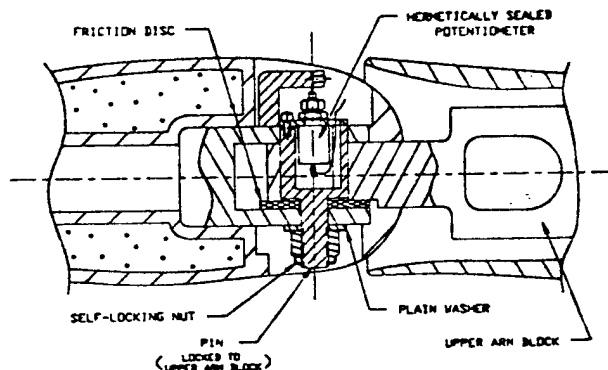

Figure 14. Typical Joint Mechanical Instrumentation Design

SPLASH DETECTION DEVICE

In order to evaluate the amount of water that might enter the mouth of an unconscious person because of wave splash, a means of evaluating the amount of water entry has been incorporated. Figure 15 shows a sketch of the system that will be utilized to evaluate the effect of water intake due to waves. The open mouth will be duplicated by a 1/4-inch x 1 1/2-inch slot. The water entering this simulated mouth opening is funneled into a removable plastic bag which can be weighed to determine the volume of water ingested.

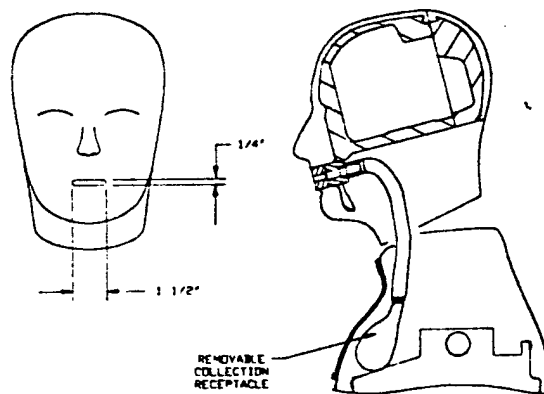

Figure 15. Splash Detection System

EMERGENCY FLOTATION DEVICE

To ensure that the manikin will resurface under any test conditions, a CO₂ cartridge will inflate a bladder if the water pressure exceeds 8 psi which corresponds to an 18-foot depth of submergence. To uncouple the activation of the emergency flotation device from the instrumentation system and its power supply, a mechanical hydrostatic switch will be used to activate the system. When the system is activated, it will inflate a bladder wrapped around the abdomen to generate

approximately 10 pounds of buoyancy to bring the manikin back to the surface. This emergency flotation device should ensure that the manikin is not lost during a test mishap. Figure 16 shows the location of the sensor and air supply.

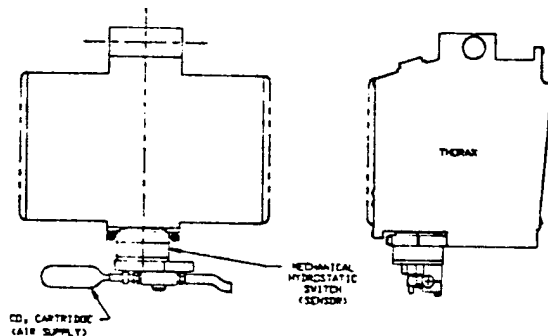

Figure 16. Emergency Flotation Device

FULL SCALE VALIDATION TESTING

The instrumented manikin will provide a new research tool to the Coast Guard. It will be used to collect quantitative data to determine human survivability in rough water. The manikin will provide a new standard for providing no-risk to human subjects, reliable, and repeatable approach to improving our understanding of the interaction of persons in waves. With the new instrumented flotation manikin experiments can be designed that will quantify factors that influence survivability in rough water, with an ultimate goal of developing probability of survival data that can be used for future guidance in selecting the optimum flotation aid.

Experimental design is a strategic approach used to increase the amount of information about some parameters of interest. In designing these experiments the parameters to be measured or observed and the factors affecting these parameters must be defined. The parameters of interest or dependent variables may be the amount of water ingested, the number of wave splashes to the face, the dynamic freeboard distance from the mouth to the free surface, and body temperature. Factors that may affect these parameters may include PFD type, wave type, clothing, swimming experience, time in water, stress levels, etc. Independent variables or variables to be controlled may include the wave type and manikin (standard under construction).

CONCLUSIONS

The ability to quantify performance of PFDs in rough water will yield improved chances of survival to the recreational and commercial boater. Performance indices such as mouth immersion frequency could be generated for rough water survival. These indices could assign probabilities to rough water performance factors.

Additionally, probability of survival charts could be developed to assist USCG Search and Rescue (SAR) operations. Since the probability of survival of an individual fallen overboard is likely to decrease over time with increasing water roughness, rough water probabilities could be factored into improved probability of survivability charts which could include hypothermia probabilities.

The WAFAC adaptation to the ATB program can be run as a FORTRAN program or as an executable from a personal computer with a minimum of a 80386 microcomputer and math coprocessor. However, the program is still in the research test and development stage.

It is believed that the manikin test device being developed will serve to complement the effort to develop a simulation capability as well as contributing to the formulation of criteria to provide superior PFDs in the future.

The opinions expressed herein are those of the authors and do not necessarily represent the views of the U.S. Coast Guard.

REFERENCES

1. Survival Factors Factual Findings Report, National Transportation Safety Board No. DCA-92- MM-029, T.D. Weaver, August 5, 1992.
2. Boating Statistics 1991, U.S. Dept. of Transportation, USCG, COMDPUB P16754.5
3. Girton, T.R. and Wehr, S.E., "An Evaluation of the Rough Water Performance Characteristics of Personal Flotation Devices," USCG-M-84-1 Report, January 1984.

4. Hart, C.J., "A Study of the Factors Influencing the Rough Water Effectiveness of Personal Flotation Devices," DTRC-88/026 Report, July 1988.
5. Steinman, A.M. CDR, "A Comparison of the Protection Against Immersion Hypothermia Provided by Coast Guard Anti-Exposure Clothing in Calm versus Rough Seas," USCG Report No. CG-D-17-85, June 1985.
6. Fleck, J.T., Butler, F.E., and Vogel, S.L., "An Improved Three Dimensional Computer Simulation of Crash Victims," NHTSA Report Nos. DOT-IIS-801-507 through 510, April 1975, Vols. 1-4.
7. Newman, J.N., "Marine Hydrodynamics," 1986.
8. Weerappuli, D.P.V., "Development of Water Forces Analysis Capability (WAFAC) for the Articulated Total Body Model," December 1991.
9. White, R.P. (et al), "Advanced Dynamic Anthropomorphic Manikin (ADAM) Final Design Report," AAMRL-TR-90-023, March 1990.