

Gulf of Mexico Helicopter Offshore System Technologies Recommended Development Path

**Edmund J. Koenke, Sc.D.
Larry Williams
Caesar Caiafa**

**May 1999
Final Report**

**DISTRIBUTION STATEMENT A
Approved for Public Release
Distribution Unlimited**

**Prepared by
System Resources Corporation
Burlington, Massachusetts**

**Prepared for
U.S. Department of Transportation
Research and Special Programs Administration
John A. Volpe National Transportation Systems Center
Surveillance and Sensors Division
Cambridge, Massachusetts**

**And
National Aeronautics and Space Administration
Ames Research Center
Advanced Air Transportation Technologies Project
Moffett Field, California**

Under Contract – DTRS-57-93-D-00070, CA 4204

20010511 106

Acknowledgement

The authors wish to acknowledge the sponsors of this effort, George Tucker of the NASA Ames Research Center's Advanced Air Transportation Technologies Project (AATT) and Robert Pawlak of the U.S. DOT Volpe National Transportation Systems Center (VNTSC), and to thank them for their contributions, guidance, and support in the conduct of this work and in the preparation of this final report.

The authors wish to acknowledge the following organizations for their assistance and cooperation in the conduct of this work: FAA Southwest Region, Chevron, Shell, and HSAC.

The authors also wish to acknowledge and thank the following individuals for their technical and editorial contributions to this effort: Dr. Paul Abramson, SRC; Robert Vivona, SRC; John Canniff, SRC; and Elisabeth Carpenter, VNTSC.

AD NUMBER	DATE 5/9/01	DTIC ACCESSION NOTICE
2001 0063		REQUE 1. Put yo on rev 2. Compl 3. Attach maile 4. Use ur infor 5. Do not for 6 DTIC: 1. Assig 2. Retu 2001051106
1. REPORT IDENTIFYING INFORMATION		
A. ORIGINATING AGENCY DOT/Volpe National Transportation Sys., Cambridge, MA		
B. REPORT TITLE AND/OR NUMBER Gulf of Mexico Helicopter Offshore...		
C. MONITOR REPORT NUMBER DOT-VNTSC-NASA-99-2 Koenke, E. et al.		
D. PREPARED UNDER CONTRACT NUMBER		
2. DISTRIBUTION STATEMENT		
UNLIMITED		

DTIC Form 50
JUL 96

PREVIOUS EDITIONS ARE OBSOLETE

Executive Summary

The National Aeronautics and Space Administration (NASA) Advanced Air Transportation Technologies (AATT) project in cooperation with the Department of Transportation (DOT) Volpe National Transportation Systems Center (VNTSC) contracted with the System Resources Corporation (SRC) for the evaluation of the existing environment and the identification of user and service provider needs in the Gulf of Mexico low-altitude Offshore Sector. The results of this contractor activity are reported in the *Gulf of Mexico Helicopter Offshore System Technologies Engineering Needs Assessment*. A recommended system design and transition strategy was then developed to satisfy the identified needs within the constraints of the environment. This work, also performed under contract to NASA, is the subject of this report.

The set of high priority user and service provider needs is based on:

- Interviews of users and service providers;
- site visits to company operations centers and the Houston Air Route Traffic Control Center (ARTCC); and,
- meetings with the Helicopter Safety Advisory Conference (HSAC) and key industry and government personnel.

The identified needs are:

- automated flight following;
- company two-way data link;
- display of traffic information in the cockpit;
- improved access to NWS weather information;
- improved weather sensing, processing, and forecasting;
- direct pilot/controller data and voice communications;
- Air Traffic Control (ATC) surveillance, tracking, and display of aircraft; and,
- instrument flight rules (IFR) procedures for reduced separations in the Gulf based on ATC surveillance.

To satisfy these needs, a set of existing and developing technologies and systems was identified and evaluated from a cost, benefit, and risk perspective. The most promising technologies were then synthesized into a recommended system and a transition strategy identified, which represents a recommended development path for the low altitude, Offshore Sector in the Gulf of Mexico.

The recommended system uses the existing commercial communications infrastructure and converts the Air/Ground communications in the cockpit and on the ground from analog to digital. Note that the digital radio technology is required to be analog-compatible so that the transition to digital radios will not preclude analog communications during the transition. An Automatic Dependent Surveillance - Broadcast (ADS-B) transponder eventually replaces the existing Air Traffic Control Radar Beacon System (ATCRBS) transponder to provide air-to-air Cockpit Display of Traffic Information (CDTI) and compatibility with the future National Airspace System (NAS). Independent or integrated operations centers are established onshore to provide the needed flight

following and weather information processing and dissemination. Communications between pilot and ATC controller can be accomplished by:

- landline connection between company operations centers and the ATC facilities such as Houston ARTCC and Terminal Radar Control (TRACON) facilities
- linking the company communications infrastructure with a Remote Communications Air/Ground (RCAG) facility; or by,
- implementing an upgraded FAA communications infrastructure.

Transition from the existing system to the recommended system is accomplished in four steps:

1. replacement of analog with digital aeronautical radios and establishment of automated company flight following and two-way data link;
2. establishment of improved weather sensing, processing, access, and distribution (increased automation of flight plan processing is also part of this second step);
3. installation of ADS-B transponders and CDTI. The ADS-B transponders replace the existing ATCRBS transponders; and,
4. obtaining FAA provided IFR services with separations approaching those of domestic en route airspace.

This approach appears to be the most cost-effective method to satisfy the user and service provider needs although it is recognized that the key ingredients to achieving these capabilities are:

- a unified users approach;
- collaboration between the users and the service providers; and,
- effective management and administration of this effort.

TABLE OF CONTENTS

Chapter	Page
1.0 INTRODUCTION.....	1
2.0 CANDIDATE SYSTEM TECHNOLOGIES	3
2.1 Technology and Systems Identification	3
2.2 Technology and Systems Evaluations	3
3.0 SYSTEM SYNTHESIS AND TRANSITION.....	10
3.1 System Synthesis	10
3.2 System Description.....	12
3.3 System Transition/Implementation Strategy	16

APPENDICES

- A. Glossary of Acronyms
- B. References

LIST OF TABLES

1.1 Summary of Needs	1
2.1 Major Needs and Applicable Technologies.....	4
2.2 Benefits, Costs, and Risks of Applicable Technologies	4
3.1 Digital VHF Radio Information	11
3.2 Recommended System Capabilities	15

LIST OF FIGURES

3.1 Recommended System Block Diagram	10
3.2 Recommended Transition Strategy	16

1.0 INTRODUCTION

The National Aeronautics and Space Administration (NASA), in partnership with the Federal Aviation Administration (FAA), is conducting a research and development program to modernize the National Airspace System (NAS). The mission of NASA's Advanced Air Transportation Technologies (AATT) project is to develop advanced Air Traffic Management (ATM) concepts and decision support tools for eventual deployment and implementation by the FAA and the private sector. One major objective of the NASA AATT project is to understand and promote the needs of all user classes.

The Gulf of Mexico (GoMex) Offshore Sector, with its large number of helicopters, has unique ATM needs that must be addressed in order to take advantage of the NAS modernization and evolution to a free flight environment. The needs of both the users and service providers have been assessed for the Gulf of Mexico offshore helicopter operations and have been documented in the *Gulf of Mexico Helicopter Offshore System Technologies Engineering Needs Assessment (ENA)*, dated May 1999. These needs are summarized in Table 1.1.

Table 1.1 Summary of Needs

Identified Need
Automate flight following
Provide company two-way data link
Provide a display of traffic information in the cockpit
Improve access to NWS weather information
Improve weather sensing, processing, and forecasting
Implement direct pilot/controller data and voice communications
Implement ATC surveillance, tracking, and display of aircraft
Develop IFR procedures for reduced separations in the Gulf based on ATC surveillance

The objectives of this report are to:

- define a concept for a system that addresses the unique needs of both the rotorcraft users and air traffic control service providers in the Gulf of Mexico low-altitude Offshore Sector;
- enable users and service providers to take advantage of existing and developing technologies to meet those needs; and to,
- determine the optimum transition path from the current to the recommended future operational capabilities in the low-altitude Offshore Sector of the Gulf of Mexico.

To accomplish these objectives, the candidate technologies capable of satisfying the needs in Table 1.1 were identified and evaluated in terms of benefit, cost and risk. This analysis is presented in Chapter 2. Next, a system design, coupled with a transition/implementation strategy, was formulated, based on the most promising technologies. Chapter 3 documents the results of the system design and transition strategy that constitute the recommended development path for the helicopter offshore system technologies in the Gulf of Mexico. Appendix A is a Glossary of Acronyms used in this document. Appendix B is a list of references used in this report.

2.0 CANDIDATE SYSTEM TECHNOLOGIES

This section relates the needs identified in the *Gulf of Mexico Helicopter Offshore System Technologies Engineering Needs Assessment (ENA)*, dated May 1999, to the existing and developing technologies and systems potentially capable of meeting the needs. The costs, benefits and risks are assessed for each of these technologies and form the basis for the recommended development path formulated in Chapter 3.

2.1 Technology and Systems Identification

A set of existing and developing technologies and systems has been identified that have the potential to satisfy the major needs of the users and service providers. The identification of these technologies and systems has resulted from a review of the existing NAS systems and the planned NAS Architecture in addition to the systems presently being used in the Gulf of Mexico environment. Table 2.1 identifies technologies applicable to the summary of major needs presented in Table 1.1. The identified technologies and systems span the spectrum from current systems to concepts in the early stages of the development process. However, many of these technologies and systems are presently available and are FAA certified.

2.2 Technology and Systems Evaluations

Table 2.2 provides the benefit, cost, and risk evaluation of the various technologies presented in Table 2.1. In the instance where a given technology is capable of satisfying more than one need it will be given more consideration in the system synthesis process. Analysis of Table 2.2 leads to the following conclusions relative to meeting the user and service provider needs. Each major need and the applicable technologies and systems are discussed in the following paragraphs.

- **Automated Flight Following And Company Two-Way Data Link:**

VHF data link (coupled with GPS) is the most cost-effective approach to providing automatic flight following and company two-way data link. An advantage of this technology is that it provides immediate flight following and two-way company data link which are high priority items for the users. VHF data link can also transmit Traffic Information System (TIS) and the Flight Information System (FIS) information once these systems are developed and deployed.

Table 2.1 Major Needs and Applicable Technologies

Identified Need	Applicable Technologies
Automate flight following	Satellite Communications; Air/Ground - Ground/Ground VHF networks; ADS-B; UAT; VDL2,3,4; ACARS
Provide company two-way data link	Satellite Communications; Air/Ground - Ground/Ground VHF networks; UAT; VDL2,3,4; ACARS
Provide a display of traffic information in the cockpit	ADS-B/CDTI Display; TIS-B
Improve access to NWS weather information	NAS-WIS; Internet; AFSS/OASIS; FIS; TWIP; DUAT
Improve weather sensing, processing, and forecasting	Weather models/ processing; AGFS; NCEP; AWC; EMC; AWOS
Implement direct pilot/controller data and voice communications	UAT; VDL 2, 3, 4; ACARS; RCAG; RCO; Radio Relays; Air/Ground - Ground/Ground VHF networks
Implement ATC surveillance, tracking, and display of aircraft	Relay automated flight following data; ADS-B; Aerostat; ODAPS; micro EARTS; PVD; DSR; FLIPR; Automated Mapping
Develop IFR procedures for reduced separations in the Gulf based on ATC surveillance	ADS-B MASPS; ADS-B Separation Standards

Table 2.2 Benefits, Costs, and Risks of Applicable Technologies

Technology/System	Benefit	Cost	Risk
Satellite Communications	High – Two-way voice and data. Available anywhere in the Gulf without additional infrastructure.	Ops cost: INMARSAT \$6.00 per aircraft per hour for 2 messages per minute. Newcomb \$4.00 per aircraft per hour for 2 messages per minute. Avionics \$10,000/ac. Cost will be higher if used for surveillance (update rates of 5 or more per minute are required).	Low for INMARSAT: System is operational. Moderate for Newcomb: Not yet certified and does not provide two-way data link or voice capability.

Technology/System	Benefit	Cost	Risk
Air/Ground-Ground/Ground VHF Networks	High - Two-way voice and data on a single frequency.	Ops cost: about \$0.53 per aircraft per hour with unlimited messages. Ground radios \$5,000 - \$10,000 per installation. Airborne radios \$5,000 - \$10,000 per installation.	Low – Gulfnet 6000, Petrocomm, Datacomm, and SOLA networks are in place. Moderate for digital radios since voice and data on a single frequency are not yet certified.
ADS-B for surveillance	High	\$5000 - \$7000 per aircraft for avionics. \$25,000 per month communications - FAA cost. \$40,000/ ground station - approximately 30 stations needed.	Low – Avionics certification of long squitter remains. Moderate – Sole means navigation with GPS needed for surveillance. Moderate – Registration errors between radar and ADS-B must be reconciled.
UAT, VDL 2,3,4	High	Unknown – Information unavailable.	Moderate – New and competing comm. technologies.
ACARS	High if used for company information and flight following.	Ops cost: \$12.00 per aircraft per hour for 2 messages per minute	Low – Operational system.
ADS-B/CDTI Display	High – Display of ADS-B traffic. Requires equipage of fleet to achieve full benefit.	Initial estimates for ground stations based on MIT/LL estimates are \$40,000 per station. ADS-B Avionics estimates are \$5,000 to \$7,000 per installation. CDTI costs are unknown.	Low to Moderate – demonstrations are planned as part of FAA Safe Flight - 21 Program.
TIS-B	High – TIS-B provides traffic information in the cockpit based on ATC surveillance.	Unknown – Information unavailable.	Moderate – Safe Flight - 21 Program.
NAS-WIS	High – Provides link to Houston ARTCC and weather and aeronautical data as well. Could be used as position reporting system.	High to FAA; Low to users. This is a national WAN that users and service providers can access to obtain significant amounts of aviation/NAS information.	Moderate to High - This is a very ambitious project and is scheduled for 2010 implementation.

Technology/System	Benefit	Cost	Risk
Internet	Moderate	Low	High – Real time availability issue
FIS	Low– Weather in cockpit.	Unknown – Information unavailable.	Moderate – Safe Flight - 21 Program.
TWIP	Low – Weather in the cockpit.	Unknown – Information not available.	Moderate - Part of NAS Architecture 4.0.
DUAT	High	Low	Low – System exists
Weather Models/processing	High – Integration of multiple sources of processing and forecasting. These are in the NAS Architecture.	Low to users since these projects are part of FAA modernization costs and if users wait, they could use the results of the development. Costs to FAA are not available.	Low – Operational models exist and can be upgraded as technology advances are proven.
AGFS			
NCEP			
AWC			
AWOS			
EMC			
AFSS/OASIS			
RCAG; RCO; Radio Relay	High - Direct pilot/controller communications.	Moderate – According to the GoMex MNS, FAA plans more Gulf installations - 6 presently exist in the Gulf, 5 are offshore	Low – RCAG and RCO are operational systems. Moderate – Radio-relay concept requires testing but could be tested for proof of concept with the existing analog system.
Relay of Automated Flight Following data for ATC surveillance	High	Low to Moderate depending on the cost of telephone and/or dedicated landlines.	High - Surveillance is not directly derived from an FAA system such as radar or ADS-B.
ODAPS or micro EARTS	High	Unknown – Information unavailable.	Low – Systems for oceanic exist.
PVD	High	No cost - would use existing PVDs.	Low – System exists.
DSR	High	Unknown – Information unavailable.	Low - Installed at Seattle.
Aerostat	Moderate	Unknown – Information unavailable.	High – Data availability issue
FLIPR	High	Unknown – Information unavailable.	Moderate – System under development.
Automated Mapping	High	Unknown – Information unavailable.	Moderate – System under development.

Technology/System	Benefit	Cost	Risk
ADS-B Separation Standards	High – Permits separations approaching domestic IFR radar standards.	Low to users -FAA has projects to establish separation standards based on ADS-B.	Moderate – Sole means navigation with GPS needed for sole means surveillance.
ADS-B MASPS		Costs to FAA are unavailable.	

- **Cockpit Display Of Traffic Information:**

This capability can be obtained in either of two ways. The first is to use the VHF data link to receive traffic information based on flight following information. This method is based on the Traffic Information Service-Broadcast (TIS-B) technology. The second is to use the ADS-B technology. Adopting the later approach provides compatibility with the evolving NAS and also can lead to FAA-provided IFR services with reduced separations. The TIS-B technology could be implemented at lower cost but would not provide an evolutionary path to IFR services.

- **Improved Access to NWS Weather Information:**

On-demand access to current weather information and products is a critical users need. Presently, the NWS products are available three times daily. In addition, FSS standard products and company radio relay of weather activity from automated weather stations or certified weather observers located on platforms are available. Users can input weather data to NWS from PIREPs, company weather observers, and automated weather observation systems. Automated information is input to NWS on a relatively continuous basis. However, retrieval of this information from NWS has been described by the users as ranging from tedious to impossible. NAS-WIS, and other networks can be investigated to determine the most cost-effective methods for distributing this data. The Internet is a major possibility in this area providing the necessary reliability and availability can be achieved.

- **Improved Weather Sensing, Processing And Forecasting:**

Improved weather information is based on the collection and integration of weather data from all available sources. This need would be satisfied by establishing a central location for the collection and processing of weather data using NCAR's Aviation Gridded Forecasting System (AGFS). The AGFS could provide an aviation weather parameter set at each node of the new GPS offshore grid system. Thus, weather processing capabilities could be upgraded as the models and forecasting technologies are developed. Additional weather sensors, strategically placed in the Offshore Sector, would improve the quality and quantity of the weather data and could result in cost savings through the reduction in the need for human observers. While obtaining weather information in the cockpit automatically is seen as a potential advantage, the users do not consider it a pressing need. However, improved weather product quality and on-demand access to weather products is considered critical.

- **Direct Pilot/Controller Data And Voice Communications:**

Direct voice and data communications can be accomplished either using a dedicated communications infrastructure with FAA relays and an FAA communications network or by using commercial networks with relays through the company operations center. The later approach is less costly to the FAA but could result in significant certification issues whereas the former approach represents a costly investment in infrastructure that would duplicate that which is already in existence. A compromise approach would be for FAA to consider leasing communications bandwidth on an existing commercial network. Another alternative is to provide a relay that connects the company ground based communications infrastructure to an FAA RCAG. Of the five existing offshore RCAGs, four have the potential for accomplishing this "bridge" connection. These are: High Island (QHI); Eugene Island (VUW); South Timbalier (TZL); and Vermillion (VRO). The RCAG located at East Breaks (QTL) does not appear to have line of sight with the commercial networks. In any case, avionics consisting of a VHF digital radio for voice and data will be compatible with any of the approaches that FAA selects to provide IFR services in the future. The specification for the digital radios requires analog and digital compatibility. Thus, the operators can replace their existing analog radios with digital without having to carry both digital and analog systems. This will enable the users to communicate with the shore-based FAA facilities even if they remain analog until NEXCOM is implemented in the 2008 timeframe.

- **ATC Surveillance Tracking and Display Of Aircraft:**

The FAA Southwest Region is considering the aerostats, owned and operated by the Department of Defense, as a source for ATC surveillance information. While this could provide a near term capability it is not always available for surveillance purposes since it is taken down during adverse weather (e.g., high wind) situations and during the night.

Surveillance can also be accomplished using ADS-B or company flight following information. The Concept of Operations for the National Airspace System in 2005 (ATS 2005 CONOPS) states that "The amount of protected airspace for each flight is greatly reduced in 2005. Many aircraft provide automatic position reporting at a sufficiently high rate that surveillance separation criteria can be applied. Many other aircraft provide automatic reporting at several-minute intervals, allowing the use of manual (*ed.: non-radar separation procedures*) separation criteria that are greatly reduced in comparison to today's standards." The ATS 2005 CONOPS goes on to say for oceanic flights that "Position Reporting: The system accommodates three levels of position reporting in 2005. Most flights report their positions automatically via data link. Based on procedural requirements that are not yet defined, some of these flights report their positions at regular and very frequent intervals. Other flights provide automatic position reports regularly but fairly infrequently (i.e., on the order of 15-minute intervals). Finally, some flights continue the current practice of very infrequent verbal position reports (on the order of one-hour intervals). Surveillance (i.e., radar-like) separation techniques are applied to those flights that provide very frequent, automatic position reports, although the separation criteria are not yet defined."

Tracking and display requirements must be satisfied once the basic surveillance data is available. It is recommended that the existing ODAPS capability be examined for this application. However, the existing PVD, micro-EARTS, DSR, FLIPR, or a new display approach are all possible solutions. Selection of the appropriate display technology may depend on certification issues and on the FAA decision concerning the method to be used to collect surveillance data since new interfaces may be required.

- **Develop IFR Procedures for Reduced Separation:**

The development of procedures for reduced separations based on the use of ADS-B is the subject of current investigations being conducted by the FAA in the Safe Flight - 21 program. RTCA in the ADS-B MASPS has suggested the development of a set of procedures based on "pseudo" radar, i.e., ADS-B surveillance information. The determination of these standards is an FAA responsibility although the user community is participating in the demonstrations being conducted in the Ohio Valley and Alaska. The use of company flight following information as a surrogate for ATC surveillance information with corresponding reduced separation standards has been discussed. However, no formal program to examine this possibility exists.

3.0 SYSTEM SYNTHESIS AND TRANSITION

3.1 System Synthesis

The system presented in this section is based on the following design considerations:

- Satisfying the major user and service provider needs;
- Providing an evolutionary path to meeting these needs;
- Utilizing existing technologies and available infrastructure; and,
- Minimizing overall system cost.

The fundamental approach to the synthesis of the proposed system and the recommended development path is to provide a step-wise implementation plan that meets the user and service provider needs. In addition, use of available infrastructure to minimize cost and existing technologies to minimize certification issues are paramount drivers of the design.

Figure 3.1 is an architectural block diagram of the recommended system design that has resulted from an examination of the alternatives in Chapter 2 relative to the above design considerations.

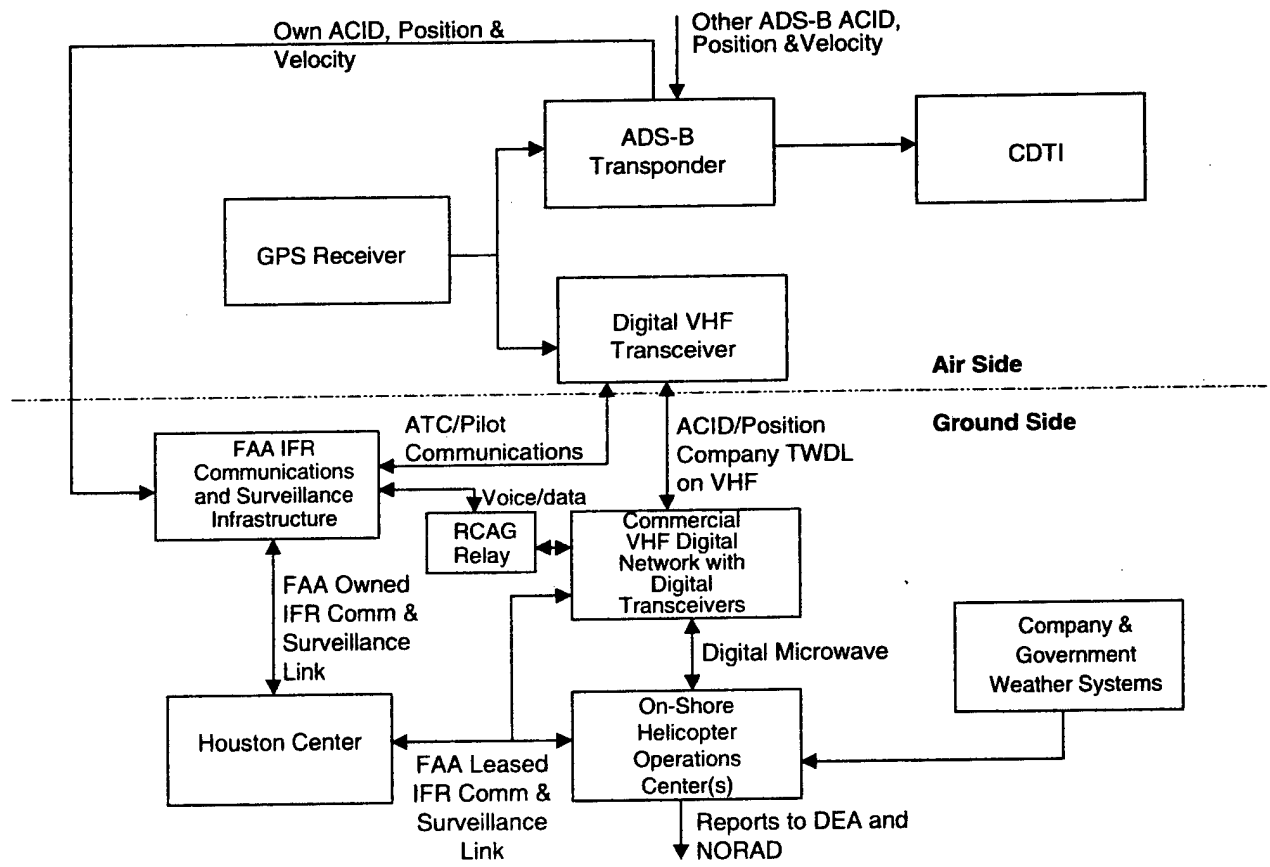

Figure 3.1 Recommended System Block Diagram

The basic avionics portion of this design consists of a GPS receiver and a digital VHF transceiver. The GPS receivers are already installed on all IFR and some VFR helicopters in the fleet and the digital VHF transceiver represents a swap out of the existing analog VHF transceivers. Table 3.1 provides information on the availability of these transceivers. Cubic, Park Air and Collins currently have units that meet the need but only the Collins radio is presently FAA certified. Collins is, however, priced for air carrier applications and not for this helicopter application. The avionics package would evolve to include an ADS-B Transponder. This would provide air-to-air CDTI capability as well as the ability to interface with the NAS where surveillance and IFR separation services are provided; and, potentially in the offshore environment should the FAA choose to invest in the required ADS-B infrastructure. This new transponder would replace the existing ATCRBS transponder in the cockpit.

Table 3.1 Digital VHF Radio Information

Mfg.	Model	Cost (K)	A-G	G-A	GPS Interface	Voice & Data	Two Way DL	Remarks
Cubic	ATC-100	\$ 7.5	X	X	X	X	X	RMMS provided, Analog and digital compatibility FAA Certification Pending
Park Air	Series 5000	\$ 5 to \$ 9	X	X	X	X	X	FAA Certification Pending FCC Certified
Collins	VHF series 700&900	\$16 to \$45	X	X	X	X	X	Primarily used on commercial A/C and high-end GA

On the ground, the existing communications infrastructure provides the linkage to an onshore Helicopter Operations Center(s) (HOCs). There could be one HOC serving all users or there could be several company owned HOCs. This is a decision that must be made by the various companies based on economics and the need for maintaining proprietary information. The HOCs will provide automated flight following, two-way data link and voice communications and would also serve as collection and processing center(s) for Gulf weather information and forecasts. Improved weather processing and forecasting as well as access to current weather can also be accomplished via the HOCs using the Internet or some other suitable network for accessing the improved weather products. The HOC will both generate improved weather products and distribute these products and those developed by other sources.

A dedicated landline to Houston ARTCC could also serve as the mechanism for providing direct pilot/controller voice and data communications via the commercial VHF digital

network, as well as a feed of the automated flight following information. Flight following information could also be provided to DEA and NORAD from the HOC(s). An alternative to the dedicated landline is an RCAG relay that would connect the commercial VHF network with the FAA RCAG network. Should FAA decide on a dedicated IFR infrastructure for surveillance and communications, the ADS-B transponder and the digital VHF transceiver would provide the needed helicopter/ATC interface. This approach (i.e., ADS-B and digital VHF communications) is consistent with the FAA NAS Architecture 4.0.

Thus, given the recommended development path, the users will achieve automated flight following, air-to-air CDTI, improved weather information, forecasting and access, and IFR capability with reduced separations. The FAA will have four options or alternatives to select from in order to obtain direct pilot/controller voice and data communications, and surveillance information at appropriate update rates. These options are:

- lease the commercial VHF communications network;
- accept voice and data via an automatic relay connecting the FAA RCAG network with the commercial VHF network;
- accept voice and data via a dedicated land-line from the HOC(s); or,
- establish a FAA infrastructure based on government-owned ADS-B and communications facilities.

3.2 System Description

The following paragraphs address each of the elements of Figure 3.1 and describe these elements in greater detail.

GPS Receiver: GPS receivers allow the helicopter fleet to be compatible with the newly established GPS Grid System, described in the ENA, and with approved GPS approaches. The GPS provides the helicopter position information needed for flight following purposes. GPS equipment as of the summer of 1998 consisted of the following: Trimble 2000/2101 – 197; Garmin 150/150xl – 120; Magellen Skynav 5000 – 30 for a total of 347 units. Presently, it has been reported by HSAC that all IFR helicopters are GPS equipped and that the trend is toward complete equipment by the Gulf helicopter fleet.

Digital VHF Transceiver: This is a new piece of avionics that would replace the VHF analog radios presently in use in the helicopter fleet. It would be required to interface with the GPS receiver in order to provide automatic position reports to the HOCs using the existing commercial VHF communications network. This transceiver should be compatible to the extent possible with FAA's NEXCOM program since this is part of the evolving NAS architecture. Chevron presently accomplishes the flight following function using an analog VHF data link and Gulfnet 6000 interfaced with their FLT TRAK system. Thus, this approach is simply a duplication of this capability using a digital link in order to increase microwave link communications capacity through the reduction in bandwidth afforded by a digital implementation. Note that the digital radio technology is required to be analog compatible so that the transition to digital radios will not preclude analog communications during the transition.

ADS-B Transponder: This is the stepping stone to obtaining CDTI capability and to being compatible with the NAS as it evolves in domestic (onshore) airspace. The ADS-B transponder would broadcast air-to-air surveillance information and would be compatible with the NAS evolution to ADS-B in airspace where radar is not available. Should the FAA decide to implement an IFR surveillance and communications infrastructure in the Gulf, this transponder and the digital VHF radio would be all of the equipment needed to be compatible. In the event that FAA chose not to implement this infrastructure, this transponder would provide air-to-air surveillance and CDTI as well as compatibility with the onshore ATC system.

Commercial VHF Digital Network with Digital A/G Transceivers: There are existing communications networks that provide coverage down to platform level virtually everywhere in the Gulf where oil exploration takes place, however, there are some areas of sparse coverage in the Galveston area. These networks include Shell Gulfnet 6000, Datacom, SOLA Communications and Consortium Partners, and Petrocomm. As an example, Gulfnet 6000 is a digital network that is based on a backbone network consisting of a set of relays established on oil platforms. Presently the VHF transceivers for A/G communications are analog and would have to be replaced with digital transceivers. The link from the platforms to the shore is accomplished using a digital microwave link. This will provide the most cost-effective means for achieving voice and data communications between offshore helicopters and the HOCs subject to the condition that a majority of users adopt this approach and share the costs of the microwave link. This concept includes the ability to communicate helicopter position information as well as a two-way data link for company information such as personnel and cargo manifests. The helicopter pilot using a bar code scanning device can automatically enter manifests. The two-way data link can also provide a positive indication to the pilot that the helicopter is being flight followed.

Onshore Helicopter Operations Center(s): These centers (or center) provide a multifunctional capability. They have the capability of providing an automated flight following service and both voice and data communications between the company and the pilot. They also have the capability of collecting and processing existing Gulf weather information for use by the company as well as by pilots of properly equipped aircraft on request. In addition, they can provide the conduit of surveillance information to Houston Center via a dedicated landline and also act as a relay for direct pilot/controller voice and data communications. These are company communication hubs that connect the offshore pilot with both the company and the ATC system and provide an automated flight following service. An interface can also be established with FAA Flight Service Stations or the ARTCC for improved search and rescue services. It should be noted that these HOCs may be partially or totally integrated depending on user/company preferences. Integration may result in the provision of these services at reduced costs.

Company and Government Weather Systems: The existing weather systems and capabilities relating to the low-altitude Offshore Sector consist of a combination of FAA, NWS, and company owned weather sources including certified weather observers on oil platforms, and automated weather observation systems (e.g., ASOS, NEXWOS). In this

development approach, weather data would be forwarded to the HOCs and would be integrated and processed to provide an improved source of Gulf weather for pilots and companies. These aviation weather products could also be made available to the FAA and NWS. Alternatively, the raw data could be provided to the FAA or to the NWS for integration and processing. The resulting weather products could then be provided to the HOCs for distribution to the user community. A key element in this service is the availability of improved weather products with timely distribution and access.

Houston ARTCC: This FAA facility is responsible for providing IFR services to the offshore helicopter community as well as to all IFR aircraft in its area of responsibility. Presently, non-radar procedures involving voice relay of helicopter position information is used to accomplish IFR separation services. Automated flight following and direct pilot/controller communications would significantly increase the efficiency of these operations. The Houston ARTCC is presently experimenting with the use of flight following information to increase the efficiency of non-radar separation procedures.

Two new automation applications currently under development are Automated Mapping and Flight Progress Reporting. Automated Mapping, a proposed PC-based tool, will automatically display route and protected airspace information directly to the controller position. Currently, a controller has to physically get up from his/her position in order to plot a helicopter's route and protected airspace using a ruler and grease pencil. Another proposed PC-based tool, Flight Progress Reporting (FLIPR), is also being developed and may be integrated into the automated mapping tool. FLIPR will display pilot progress reports via company data-link communications. The intent is for non-verbal position reports to be displayed for continuous updates of where the aircraft has been, allowing more efficient use of non-radar airspace. These tools are not intended to remove restrictions imposed by non-radar separation standards but rather, will allow more efficient use of the airspace.

FAA IFR Infrastructure: Should the FAA choose not to use the available communications infrastructure or an RCAG relay, or the flight following information available from the HOCs, an independent communications and surveillance infrastructure would have to be established to provide improved IFR services with reduced aircraft separation. Based on the NAS Architecture and the ATS CONOPS, this infrastructure would likely consist of an ADS-B capability for surveillance and NEXCOM for communications. The ADS-B transponder and the digital VHF transceiver would be compatible with these FAA infrastructure elements. Thus, the users would have achieved their stated needs and would also be compatible with whatever path the FAA chooses to provide improved IFR services.

The capabilities achieved by the recommended system are summarized in Table 3.2. This recommendation satisfies all identified needs for both the users and the service providers. It also ensures that the service providers will be compatible with whatever approach the FAA selects to provide IFR services in the Gulf Offshore Sector. The approach also provides immediate benefits to the users in a manner that is compatible with the planned NAS evolution and forestalls installation of additional equipment until the FAA makes firm decisions on their course of development and implementation.

Table 3.2 Recommended System Capabilities

Identified Need	Applicable Technologies	Selected Technologies and Systems	Recommended System Capabilities
Automate flight following	Satellite Communications; Air/Ground - Ground/Ground VHF networks; ADS-B; UAT; VDL2,3,4; ACARS	GPS; ground comm. networks; digital VHF voice and data links	Automated position reporting for all Gulf operators
Provide company two-way data link	Satellite Communications; Air/Ground - Ground/Ground VHF networks; UAT; VDL2,3,4; ACARS	Ground communications networks; digital VHF voice and data links	Two-way data link capability
Provide a display of traffic information in the cockpit	ADS-B/CDTI Display; TIS-B	Multipurpose ADS-B/CDTI display with datalink textual and graphical traffic display capabilities	Cockpit display of traffic and data link messages
Improve access to NWS weather information	NAS-WIS; Internet; AFSS/OASIS; FIS; TWIP; DUAT	Internet in the near-term; NAS-WIS in the long term	On demand access to timely weather products
Improve weather sensing, processing, and forecasting	Weather models/ processing; AGFS; NCEP; AWC; EMC; AWOS	Additional weather sensors coupled with the Aviation Gridded Forecast System	Integrated weather data collection, processing and forecasting capability
Implement direct pilot/controller data and voice communications	UAT; VDL 2, 3, 4; ACARS; RCAG; RCO; Radio Relays; Air/Ground - Ground/Ground VHF networks	VHF voice and data links	Direct pilot/controller communications
Implement ATC surveillance, tracking, and display of aircraft	Relay automated flight following data; ADS-B; Aerostat; ODAPS; micro EARTS; PVD; DSR; FLIPR; Automated Mapping	ADS-B for surveillance with ODAPS, micro-EARTS, or the FAA Southwest Region FLIPR system for tracking and display	ADS-B surveillance capability with automatic tracking and electronic display of low altitude offshore aircraft
Develop IFR procedures for reduced separations in the Gulf based on ATC surveillance	ADS-B MASPS; ADS-B Separation Standards	ADS-B Separation standards for pseudo-radar	Reduce existing non-radar separations in the Gulf based on the results of FAA use of ADS-B in domestic non-radar airspace

3.3 System Transition/Implementation Strategy

The recommended transition strategy from the existing capabilities of today's system to the recommended system is depicted in Figure 3.2.

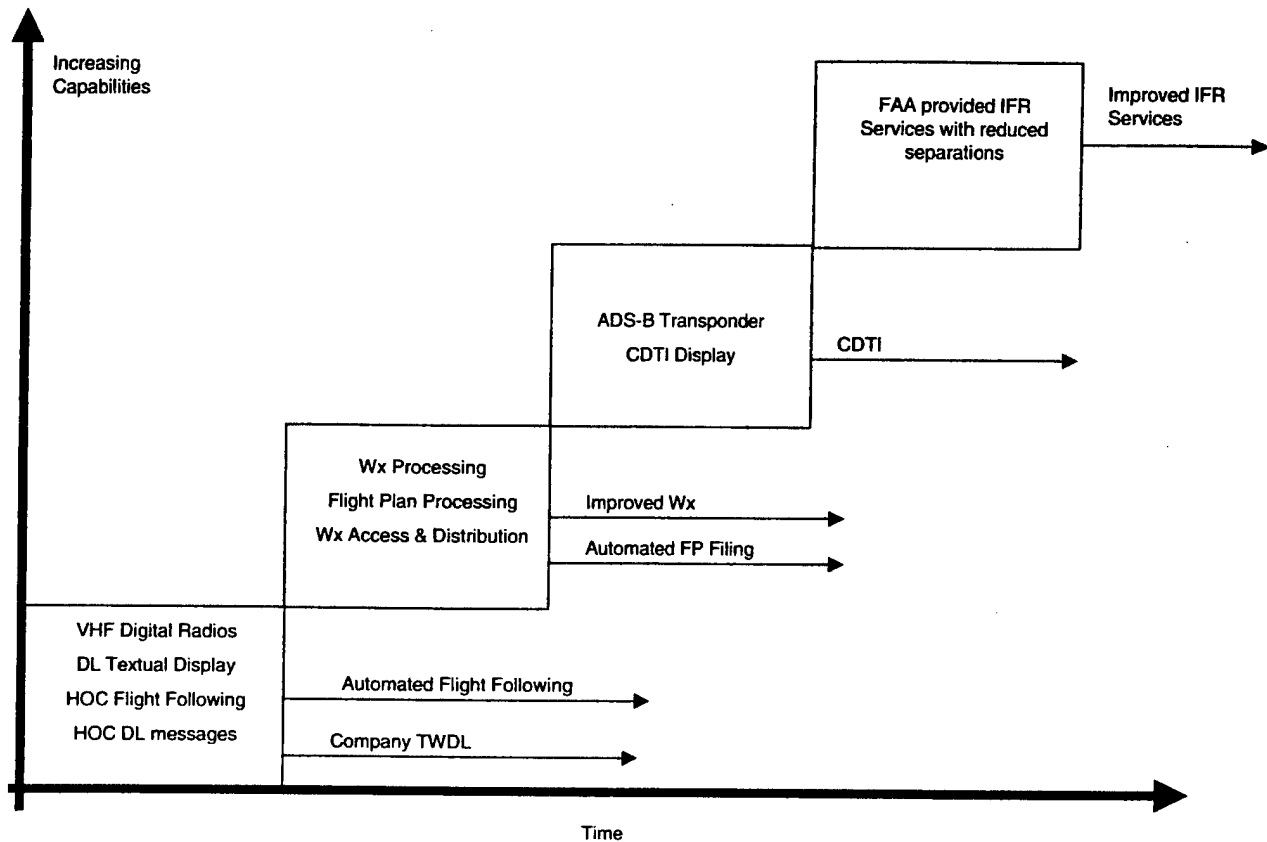

Figure 3.2 Recommended Transition Strategy

The transition steps indicated in Figure 3.2 begin with the implementation of the digital VHF voice and data capability in the cockpit and in the existing ground communications network infrastructure. Transition entails swapping out the analog VHF voice radios for digital VHF voice and data radios and providing a textual data display in the cockpit. This will immediately provide automated flight following capability once the appropriate software is installed in HOCs. The extent of this software development remains to be determined. However, Newcomb and FLT TRAK both have flight following software available. Part of this first step includes the installation of a textual data link display in the cockpit in order that the company two-way data link (TWDL) can become operational. Software and hardware, consisting of a redundant server, for message formatting and message traffic handling must also be implemented at the HOCs. One of the first messages on this link is expected to be a confirmation to the pilot that he is being flight followed. Personnel and cargo manifests and other information can be included as the capability matures. This will likely include some hardware changes or additions to allow for the selection of such an automated entry method. This implementation will provide the

users with automated flight following and company TWDL. These are considered the highest priority needs by the user community in the Gulf. At this point in the transition, the users may offer this automated flight following information to the FAA at Houston ARTCC or at other FAA ATC facilities. It is important to maintain close relations with the appropriate Air Traffic and Flight Standards personnel during this entire transition period in order to facilitate FAA acceptance and implementation.

The second step in the transition strategy consists of providing the weather data collection and processing capabilities, possibly at the HOCs. This capability comes with no additional avionics cost or weather sensor costs but requires central processing of all available weather data. Additional weather sensors would, however, improve these weather products and would reduce the cost of weather observers stationed on the platforms.

The third transition step will provide a cockpit display of traffic information (CDTI). The recommended approach is to swap out the existing ATCRBS transponders for an ADS-B transponder. This provides air-to-air surveillance of near by aircraft and also provides compatibility with the evolution of the NAS to ADS-B. An alternative is to use the FAA's Traffic Information System-Broadcast (TIS-B) which would eliminate the need for the transponder swap out but would not provide compatibility with the evolution to ADS-B should the FAA decide to install an ADS-B infrastructure in the Gulf Offshore Sector. Once this third step is accomplished, the users are compatible with whichever direction the FAA selects to provide IFR services with reduced separation capabilities in the Gulf. This third step completes the transition for the user community. The remaining steps are those of the FAA.

The last transition step is provided by the FAA and will furnish IFR services with reduced aircraft separation. This can be accomplished either with the automated flight following data being provided by the users to the FAA via landline or by the installation of a separate ground infrastructure for ADS-B surveillance and pilot/controller communications. The approach of using a landline to provide flight following information and direct pilot/controller communications has inherent certification problems because of reliability issues. However, the users will be in a position to participate in the IFR system without the need for additional avionics regardless of the approach taken by FAA. In addition, also independent of the approach taken by the FAA, is the need for a display of the surveillance data at the ARTCC. The recommended approach to fill this need is to use either the ODAPS or the Micro-EARTS system, both of which are available and certified. Similarly, surveillance data can be provided at the TRACON using ADS-B when FAA ground stations are available or again using the flight following data which can be supplied via landline. Display of surveillance information at the TRACON is, however, another matter and may require a separate development if ARTS or STARS adaptations cannot be made.

In summary, the avionics required to achieve these capabilities consists of the replacement of the existing analog radios and the ATCRBS transponders with digital radios and an ADS-B transponder coupled with the installation of a textual display in the

cockpit for TWDL. When ADS-B air-to-air surveillance information is available and displayed using a CDTI, it is feasible to use the same display for data link information.

On the ground, including offshore, the replacement of analog air-ground transceivers with digital transceivers, additional weather sensors, and the establishment of independent or integrated HOCs is also required. This approach appears to be the most cost-effective method to satisfy the user and service provider needs although it is recognized that the key ingredients to achieving these capabilities is a unified users approach, collaboration between the users and the service providers, and the effective management and administration of this project. Absolutely critical to the implementation of the development path recommended in this report is the acceptance of the approach by the FAA and their willingness to certify the associated equipment and procedures.

APPENDIX A: Glossary of Acronyms

AATT	Advanced Air Transportation Technologies
ACARS	Aircraft Communications and Reporting System
ACID	Aircraft Identification
ADS-B	Automatic Dependent Surveillance - Broadcast
AFSS	Automated Flight Service Station
A/G	Air to Ground
AGFS	Aviation Gridded Forecast System
ARTCC	Air Route Traffic Control Center
ARTS	Automated Radar Terminal System
ATC	Air Traffic Control
ATCRBS	ATC Radar Beacon System
ATM	Air Traffic Management
ATS	Air Traffic Services
AWC	Aviation Weather Center
AWOS	Automated Weather Observing System
CDTI	Cockpit Display of Traffic Information
CONOPS	Concept of Operations
Comm	Communications
DEA	Drug Enforcement Agency
DL	Data Link
DSR	Display System Replacement
DUAT	Direct User Access Terminal
EARTS	En route Automated Radar Terminal System
EMC	Environmental Modeling Center
ENA	Engineering Needs Assessment
FAA	Federal Aviation Administration
FCC	Federal Communications Commission
FIS	Flight Information System
FLIPR	Flight Progress Reporting
FSS	Flight Service Station
G/A	Ground to Air
G/G	Ground to Ground
GoMex	Gulf of Mexico
GPS	Global Positioning System
HOC	Helicopter Operations Center
HSAC	Helicopter Safety Advisory Conference
IFR	Instrument Flight Rules
MASPS	Minimum Aviation System Performance Standards
MIT/LL	Massachusetts Institute of Technology/ Lincoln Laboratory
MNS	Mission Needs Statement
NAS	National Airspace System
NASA	National Aeronautics and Space Administration
NAS-WIS	National Airspace System –Wide Information System
NCAR	National Center for Atmospheric Research

NCEP	National Center for Environmental Prediction
NEXCOM	Next Generation Air/Ground Communications
NEXWOS	Next Generation Weather Observation System
NORAD	North American Air Defense Command
NWS	National Weather Service
OASIS	Oceanic System Improvement Study
ODAPS	Oceanic Display and Processing System
Ops	Operations
PIREP	Pilot Report
PVD	Plan View Display
RCAG	Remote Communications Air/Ground
RCO	Remote Communications Outlet
RMMS	Remote Maintenance Monitoring System
RTCA	Radio Technical Commission for Aeronautics
SOLA	SOLA Communications and Consortium Partners
STARS	Standard Terminal Automation Replacement System
TIS-B	Terminal Information Service - Broadcast
TRACON	Terminal Radar Control
TWDL	Two-way Data Link
TWIP	Terminal Weather Information for Pilots
UAT	Universal Access Transponder
VDL	Very High Frequency Data Link
VDL n	VHF Data Link Mode n
VFR	Visual Flight Rules
VHF	Very High Frequency
WAN	Wide Area Network
Wx	Weather

APPENDIX B: References

1. *Gulf of Mexico Helicopter Offshore System Technologies Engineering Needs Assessment (ENA)*, NASA document in preparation, May 1999.
2. *National Airspace System Architecture 4.0*; Federal Aviation Administration, January 1999
3. *Joint Government/Industry Roadmap for Free Flight Operational Enhancements*; RTCA Select Committee, August 1998
4. *Minimum Aviation System Performance Standards for Automatic Dependent Surveillance Broadcast (ADS-B)*; RTCA Paper No. 007-98/TMC-308; Prepared by SC-186, January 8, 1998
5. *Air Traffic Services Concept of Operations for the National Airspace System in 2005 Narrative*; Final, September 30, 1997