



**PREDICTABILITY, WORK-FAMILY CONFLICT,
AND INTENT TO STAY:
AN AIR FORCE CASE STUDY
THESIS**

Patrick J. Obruba, Captain, USAF
AFIT/GEE/ENV/01M-13

**DEPARTMENT OF THE AIR FORCE
AIR UNIVERSITY**

AIR FORCE INSTITUTE OF TECHNOLOGY

Wright-Patterson Air Force Base, Ohio

APPROVED FOR PUBLIC RELEASE; DISTRIBUTION UNLIMITED.

20010612 153

The views expressed in this thesis are those of the author and do not reflect the official policy or position of the United States Air force, Department of Defense, or the U. S. Government.

**PREDICTABILITY, WORK-FAMILY CONFLICT,
AND INTENT TO STAY:
AN AIR FORCE CASE STUDY**

THESIS

Presented to the Faculty

Department of Systems and Engineering Management

Graduate School of Engineering and Management

Air Force Institute of Technology

Air University

Air Education and Training Command

In Partial Fulfillment of the Requirements for the
Degree of Master of Science in Engineering and Environmental Management

Patrick J. Obruba, B.S.

Captain, USAF

March 2001

APPROVED FOR PUBLIC RELEASE; DISTRIBUTION UNLIMITED.

**PREDICTABILITY, WORK-FAMILY CONFLICT,
AND INTENT TO STAY:
AN AIR FORCE CASE STUDY**

Patrick J. Obruba, B.S.

Captain, USAF

Approved:



Michael T. Rehg, Major, USAF (Chairman)

01 Nov 01
date

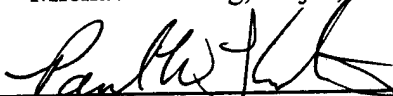

Paul W. Thurston, Major, USAF (Member)

01 Mar 01
date

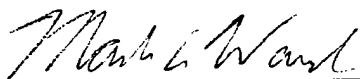

Mark A. Ward, Major, USAF (Member)

01 Mar '01
date

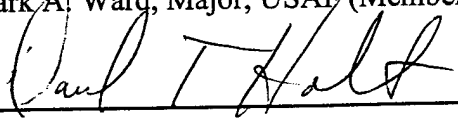

Daniel T. Holt, Captain, USAF (Member)

01 MAR 01
date

Acknowledgments

This thesis is dedicated to the nineteen expeditionary airmen who gave their lives in the service of their country in the terrorist bombing at the Khobar Towers military housing complex, Dhahran, Kingdom of Saudi Arabia, 25 June 1996.

I would like to express my sincere appreciation to my faculty advisor, Major Michael Rehg, for his enthusiasm and guidance throughout the course of this thesis effort. I would like to also acknowledge the efforts of several other faculty members: Major Mark Ward for sharing his expertise in scientific methodology, Major Paul Thurston for lending his knowledge of Structural Equation Modeling, and Captain Danny Holt for offering his wisdom in measurement theory. I also would like to thank Mr. Mark McFadden and Mr. Ed Hess for their outstanding support in creating and maintaining the World Wide Web survey site.

Patrick J. Obruba

Table of Contents

	Page
Acknowledgments	ii
List of Figures	v
List of Tables	vi
Abstract	vii
I. Introduction	1
The Reemergence of an Expeditionary Mindset.....	1
The Expeditionary Air Force Program.....	2
Research Purpose.....	5
II. Literature Review	12
Past Expeditionary Experience: The Background.....	12
Deployment Challenges: The Problem.....	13
EAF: The Solution.....	16
Intent to Stay: The Outcome.....	18
Job Satisfaction and Organizational Commitment: The Antecedents.....	21
Work-Family Conflict: EAF Specific Antecedent.....	22
Predictability: The Theoretical Solution.....	25
Construct Relationships: The Model.....	32
III. Methodology	34
Design.....	34
Population and Sampling Information.....	35
Nature of the Data.....	39
Construct Measures.....	39
Statistics.....	45
IV. Analysis	47

	Page
Factor Analysis.....	47
Descriptive Statistics.....	48
Confirmatory Structural Equation Modeling.....	55
Between-Groups Analysis.....	58
Summary.....	63
V. Discussion.....	65
Research Question.....	65
Implications for the Air Force.....	65
Implications for The Presence of Dependents.....	68
Implications for the EAF.....	68
Generalizability.....	69
Research Impact.....	71
Limitations.....	72
Final Thoughts.....	74
Appendix A: Survey Package.....	75
Appendix B: Descriptive Statistics.....	85
Appendix C: Sample LISREL Program.....	94
Appendix D: Relevant Survey Comments.....	96
Bibliography.....	107
Vita.....	112

List of Figures

	Page
Figure 1. Construct Model: Tett & Meyer (1993).....	7
Figure 2. Construct Model: Tett & Meyer (1993) and Lance (1991) Combined, Initial	9
Figure 3. Construct Model: Tett & Meyer (1993) and Lance (1991) Combined, Final.....	9
Figure 4. Air Force Strength vs. Deployments, 1988-1999	14
Figure 5. AEF Deployment Cycle.....	17
Figure 6. Spector Model of Job Satisfaction/Retention Constructs	19
Figure 7. Model of Construct Relationships	33
Figure 8. Overall Sample Size Calculation	36
Figure 9. Structural Equation Model of Construct Relationships	46
Figure 10. Enlisted Breakdown by Rank Percentage.....	52
Figure 11. Officer Breakdown by Rank Percentage	52
Figure 12. Breakdown by Air Force Specialty Code, AEF Sub-Group.....	53
Figure 13. Breakdown by Air Force Command, AEF Sub-Group.....	54
Figure 14. Path Analysis Model of the Impact of Predictability on Intent to Stay	57
Figure 15. Predictability--WFC Regression Plot, EAF Status	60
Figure 16. Predictability--WFC Regression Plot, Dependent Status	60
Figure 17. Path Analysis Model, Dependent Status Sub-Groups	63

List of Tables

	Page
Table 1. Air Force Officer Career Intentions, 1986-1999	21
Table 2. Air Force Enlisted Career Intentions, 1989-1999	21
Table 3. Sampling Stage Summary	38
Table 4. Response Rate Summary.....	38
Table 5. Stephens & Sommer WFC Confirmatory Factor Loadings	41
Table 6. Factor Analysis Loading	48
Table 7. Descriptive Statistics and Correlation for all Constructs	49
Table 8. Descriptive Statistics by AEF & Dependent Status Categories Across All Measures.....	50
Table 9. Demographic Comparison of Sample to Population.....	51
Table 10. Confirmatory Structural Equation Model Statistic Summary.....	56
Table 11. MANOVA Summary of Between Group Measures	59
Table 12. AEF Status Sub-Group Comparison for the Predictability--WFC Path Constraint	62
Table 13. Dependent Status Sub-Group Comparison for the Predictability--WFC Path Constraint	63

Abstract

A survey was completed by 362 active duty Air Force members in December 2000 regarding their perceptions of schedule predictability, work-family conflict, job satisfaction, organizational commitment, and intent to stay with the Air Force. Theory suggests that a program designed to create schedule predictability, the Expeditionary Aerospace Force (EAF), would moderate the relationship between predictability and intent to stay. Using Structural Equation Modeling (SEM), plausible evidence was found to support the idea that schedule predictability plays a role in intentions to stay via work-family conflict, job satisfaction, and organizational commitment. Additional evidence supported the theory that the path relationships generated via SEM changed in strength for demographic sub-categories based on the presence of dependent family members, but not for sub-categories based on assignment under the EAF.

**PREDICTABILITY, WORK-FAMILY CONFLICT,
AND INTENT TO STAY:
AN AIR FORCE CASE STUDY**

I. Introduction

The Reemergence of an Expeditionary Mindset

The world is changing fast. New threats, new technologies, and new tools are changing the way we prepare for conflict. The 21st century Air Force must be ready for the challenges....The Expeditionary Aerospace Force defines our structure, culture, and operations. We need to be a light, lean, and lethal fighting machine, prepared to make and keep the peace. Built in this concept is a mindset that we are ready to go anywhere, anytime to carry out our mission. (Air Force Manual 10-100, 1999, n. pag.)

Emergent from the chaos and uncertainty in the worldwide arena of Twenty-first Century is a return to traditional airpower deployment. The United States air forces, as a branch of the Army, acted as an expeditionary organization in World War I and in both theaters of World War II. Expeditionary United States airmen defended not their home soil, but that of an ally, yet in each instance, they defended that soil as if it were their own. Borrowing from Air Force Field Manual 10-100, expeditionary means, "...ready to go anywhere, anytime to carry out our mission" (1999, n. pag.). The expeditionary mindset exists at the root of Air Force tradition in the actions of early American airmen such as Mitchell, Arnold, and Kenney (For a more thorough history of the Air Force as an expeditionary force, see Davis, 1998).

But the bipolar world of communism versus democracy that those airmen left us has disappeared. Within the context of this new world, the confluence of an alarmingly ill defined threat with a decreased budget and personnel pool present role-defining challenges for the Air Force. Thus, the United States airmen of the new century are poised at a unique crossroads. At one side of that crossroads, a growing reliance on the Air Force as a political enforcing agent by the US has created an increase in the Operations Tempo (OPSTEMPO), or the frequency and duration of time airmen spend away from their home stations. The OPSTEMPO increase has impacted Air Force readiness, morale, retention, recruiting, and modernization (Expeditionary Aerospace Force, 1999). At the other side of that crossroads is a general decline in strength (or number of airmen), a manifestation of the post Cold War “peace dividend” (Expeditionary Aerospace Force, 1999). For the remainder of this report I will use the term “airmen” to identify active duty enlisted and officer personnel in the United States Air Force.

The Expeditionary Air Force Program

Recent Expeditionary Operations. Examples of the recent employment of airpower include limited regional conflicts such as Operations NORTHERN WATCH and SOUTHERN WATCH in the Middle East and Operation ALLIED FORCE in Kosovo, Yugoslavia. In these operations, the utilization of expeditionary air power was as a primary and unilateral tool of enforcing political will. These missions, along with the humanitarian relief and peacekeeping efforts commonly referred to as Military Operations Other Than War (MOOTW), have spawned a new force deployment mindset

that is not all that different from that of the Air Force's founders, the Expeditionary Aerospace Force (EAF).

A Change in Philosophy. In the Fall of 1999, the United States Air Force initiated a change in deployment philosophy known as the EAF. The program borrows its key term, "expeditionary", from that used to describe US Army Air Force units in World War I. Essentially, the EAF paradigm is designed to provide the air power leader, "...the tools to better manage the force, determine its stresses, and when, where, and how to focus contingency OPSTEMPO relief" (Expeditionary Aerospace Force, 1999, n. pag.). At its most basic level, the EAF organizes the Air Forces of the United States into units designed as they would be needed on a deployment and provides those units with a predictable schedule by which all airman, from the unit commander to the most junior enlisted member, may plan their lives.

Problems Prior to EAF. While aircraft and pilots typically deployed according to their home base assignment, Expeditionary Combat Support (ECS) personnel (including but not limited to, logistics, maintenance, civil engineer, communications, and services) deployed on an individual basis prior to the EAF, under a program known as Palace Tenure. Palace Tenure deployed most support personnel one individual at a time, removing them from their home units and attaching them to provisional organizations overseas. Thus, airmen who often times had never worked together before were forced to adapt to not only a new physical environment, but a new working one as well. With the EAF, these personnel train and deploy along with assigned aircraft units as complete entities during a scheduled window of deployment vulnerability.

A Return to Tradition. While it would be easy for the casual observer of the EAF program implementation to claim a loss of tradition, this argument is based on the Air Force of recent memory: the forward deployed, Cold War, nuclear deterrent force of the 1950s through the late 1980s. The certainty of the Cold War is no more. The EAF reaches deeper into the traditions of United States flying forces, World War I and World War II, to interact with that uncertain future with a mobile and flexible force.

A Necessary Change. According to Jane's International Defense Review, "The EAF plan is not something the USAF wanted to do, but something it had to do...the Air Force sees the EAF as a way to accomplish its missions, while maintaining its long-term investments and arresting a threatened decay in readiness" (Sweetman, 2000). The two main challenges of the EAF program, and key aspects of readiness, are (a) to operationally train and deploy Air Force combat forces in the most appropriate manner and (b) to provide units, airmen, and families the schedule stability and predictability they need to plan for time off, training, and school (Expeditionary Aerospace Force, 1999). For the remainder of this report, the term "predictability" will be used to represent stability and predictability, collectively.

A Link Between the EAF and Retention. A primary issue of concern, not only to the Air Force, but the DoD as a whole is the job satisfaction of airmen and its impact on retention. Bernard D. Rostker, prior to his confirmation as Undersecretary of Defense for Personnel and Readiness, indicated that, "...the key to retaining mid-grade officers and enlisted personnel is 'job satisfaction, which includes the off-duty as well as the duty environment'" (Washington, 2000, p. 6). He suggests that deployment uncertainty, manifested by too many or too few deployments, can lead to decreased job satisfaction

and commitment to the organization. Thus the EAF, in establishing a system to standardize deployment and training schedules, may have a significant impact on retention. His reference to the off-duty environment is an acknowledgment that airmen's families are integral parts of the decision to stay with the Air Force as well. The US General Accounting Office (GAO), in a report to Congress, indicated that among key indicators for the stresses that the current deployment requirement causes on the Air Force are a decline in recruiting and retention along with less predictability of deployments for personnel and their families (GAO, 2000). While acknowledging the potential benefits of the EAF program to compensate for these stresses, the GAO report suggests that:

More quantifiable goals [in addition to current Air Force goals and measures] and a comprehensive analysis of progress toward meeting these goals could provide the Air Force with the management information needed to know whether the Expeditionary Concept is an improvement over past deployment patterns or whether adjustments to the Concept are needed. (p. 26)

Research Purpose

Current Studies. The majority of studies pertaining to the EAF focus on the operational deployment aspects of the new deployment paradigm. This work is not an attempt to question the soundness of the program in terms of military strategy and its effectiveness as a weapon of war, rather, it is an objective look at the impact that such a strategy has upon Air Force members' lives. No previous studies were found which focused on the second major challenge of the EAF, predictability, from a behavioral science approach. Currently, the Air Force measures predictability in terms of the number of days that an individual is notified of a deployment, prior to actually deploying

as well as tracking the number of days spent away from home station. This study should act as a companion to such objective measures and help provide a more comprehensive analysis of the expeditionary concept. To fill the need for a more thorough analysis, this study examines the effect of the EAF program on predictability and other work-related concepts. Specifically, the study explores the program's impact as one of the factors affecting the retention of deployable Air Force members.

Thesis Focus. The study focuses on the effects of the EAF on active duty members as a distinct group, one tied by a common bond of deployment experiences and culture. Reserve forces, while called upon by EAF plans, are not included in this study. Most likely, the reservists' dual roles as citizen-soldiers bring into play different issues than active duty airmen. The balance of active duty Air Force military personnel, such as those involved in materiel acquisition and research or non-deployable functional staffs, are used as a comparison group. The study also seeks to determine if the presence of dependents in an airman's life impacts the manner through which the EAF program impacts retention.

Relevant Theoretical Constructs. This study is an attempt to evaluate, in part, an existing program. The first step in this evaluation is to understand the practical environment in which the program was employed. The Air Force, within the context of its expeditionary background, reacted to the problems of increased OPSTEMPO and decreased personnel strength, in a sense, being asked to deploy more with less personnel, by implementing the EAF program. Providing a meaningful schedule seemed like an appropriate response to a deployment system that lacked order. The anticipated outcome

of such a solution is greater predictability of work schedules, leading to improved retention of trained personnel.

Relating Job Satisfaction, Organizational Commitment, and Intent to Stay. The second step, and a primary goal of this thesis, is to apply the theoretical framework on top of the Air Force's actions through the use of a construct model. Tett and Meyer (1993) offer us a portion of that framework. In a path analysis based on a meta-analytic review of job satisfaction, organizational commitment, intent to quit, and turnover, Tett and Meyer found support for a relationship as indicated in Figure 1. They found that both job satisfaction and organizational commitment contributed independently to intent to quit (with job satisfaction's contribution the more significant of the two), and that intent to quit subsequently predicted actual turnover.

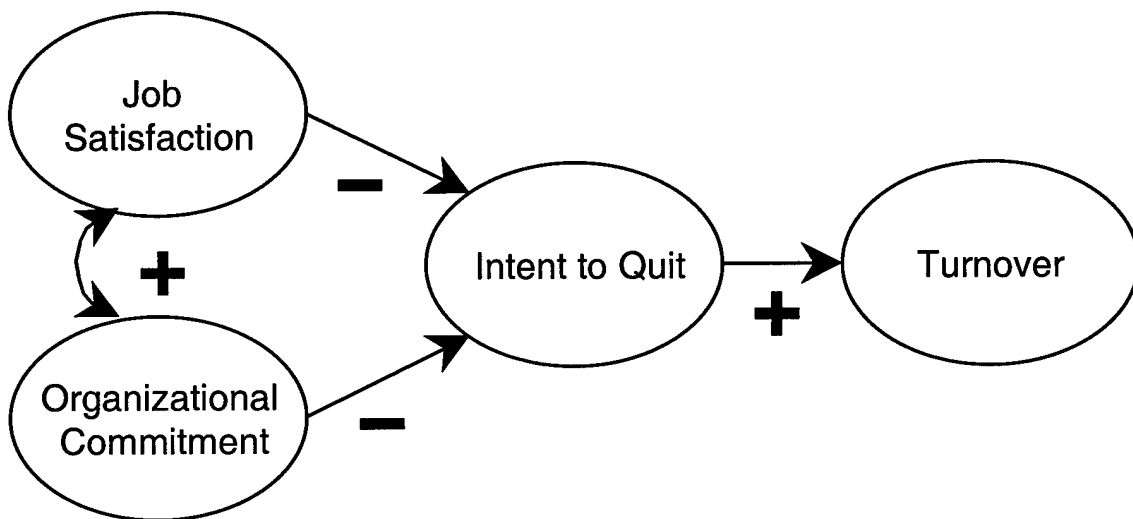

Figure 1. Construct Model: Tett & Meyer (1993)

Intent to Stay as a Substitute for Retention. Due to study limitations, actual turnover cannot be measured, so intent will serve as a substitute. Additionally, the Air

Force tends to refer to the struggle to keep its personnel from leaving the Service in the positive context (retention) rather than the negative context preferred by the literature (turnover). Thus, the term “intent to stay” will be used in place of intent to quit, reversing the polarity of all influencing relationships upon the construct, but better fitting the context of the Air Force. Research conducted by Lance (1991) indicates both job satisfaction and organizational commitment, in the context of their impact on retention, arise from overlapping sets of work environment perceptions.

Relating Work-Family Conflict and Predictability. Lance (1991) goes on to discuss another indicated impact on retention: role stress. This study examines EAF Work-Family Conflict (WFC) as a specific form of Lance’s suggested work environment perception in the form of a role conflict. Many, but not all, deployed airmen fill two roles, one as expeditionary warriors and one as a family member with others who require their support. For the purposes of this research, the study classifies such family members as dependents. Because dependent situations vary, the importance of the relationship between predictability, work-family conflict, and retention should vary as well (the more severe the dependence, the more important the path is as compared to all other paths). Such role stress (created when there are conflicts to simultaneously fill both roles) is often defined as WFC. If one has a friction between what their work and family ask of them (WFC), then most likely their work behavior will be altered to reflect a decrease in job satisfaction and a similar decrease in commitment to the organization. Figure 2 combines the Tett and Meyer (1993) and Lance (1991) models along with the use of the term “intent to stay” in place of “intent to quit.” Figure 3 incorporates predictability into the Tett & Meyer (1993) and Lance (1991) combined model.

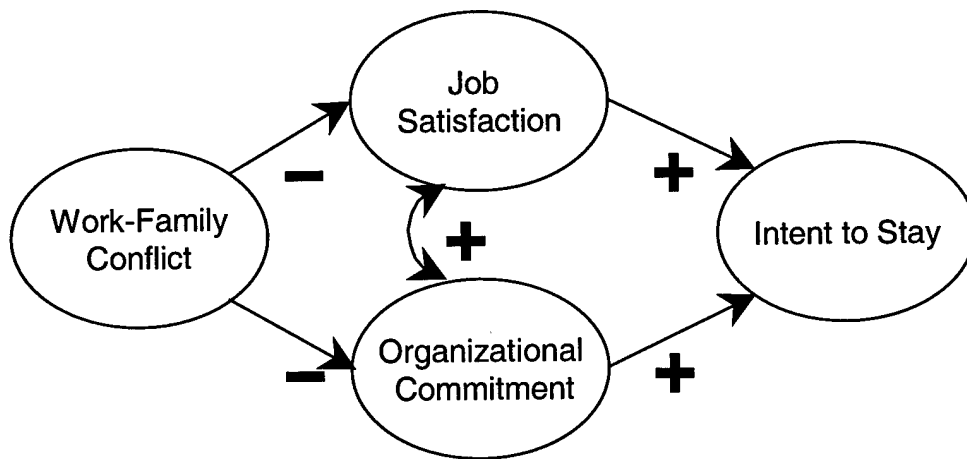

Figure 2. Construct Model: Tett & Meyer (1993) and Lance (1991) Combined, Initial

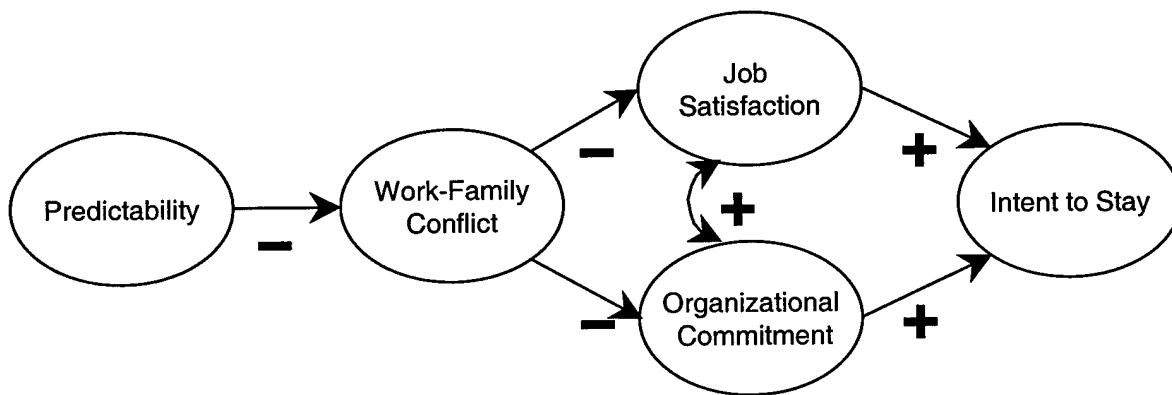

Figure 3. Construct Model: Tett & Meyer (1993) and Lance (1991) Combined, Final

Research Question and Hypotheses. In the thesis, I attempted to answer the following research question by applying the theorized construct model in Figure 3 to a random selection of airmen.

Research Question: *How has predictability influenced the intent to stay of active duty Air Force personnel?*

An initial justification of the model was required to further examine the influences of predictability on intent to stay. To begin to study those influences, the study focused on the first hypothesis:

Hypothesis 1: *Predictability, through a combination of intermediate constructs, has a positive impact on intent to stay.*

After examining the overall model fit, the study attempted to uncover a deeper relationship. If one has dependents, then a construct that deals specifically with a role conflict that requires some level of dependent presence (WFC), it seems intuitive that an attempt to mediate that role stress will cause those constructs to have greater importance for an individual. The study offered the following hypothesis to examine the dependent effects:

Hypothesis 2: *Respondents who are supporting dependents will show a stronger relationship between predictability and work-family conflict than those without dependents.*

After looking at the effect of dependents, the study examined another relationship that divided the sample population: assignment to under the EAF. If one is assigned under a program directed toward reducing WFC, then it also seems intuitive that being a part of that program will increase the importance of such a relationship between the program

(predictability) and WFC, if such a program is effective. The study offered the additional hypothesis to examine this relationship:

Hypothesis 3: *Respondents reporting assignment to an AEF will show a stronger relationship between predictability and work-family conflict than those not reporting AEF assignment.*

Thesis Overview. This thesis attempts to answer the research question with the guide of the four hypotheses. In chapter two, a review of the literature relevant to the hypothesized construct relationships was conducted. In chapter three, the procedure by which data was gathered and analyzed was summarized. In chapter four the data analysis are reported. The fifth and final chapter discussed the implications of the data analysis in answering the research questions.

II. Literature Review

Past Expeditionary Experience: The Background

Undercurrent of Expeditionary Tradition. As mentioned earlier, the Army Signal Corps and Air Corps, predecessors to the present day Air Force, deployed in an expeditionary manner throughout its history. Dowdy (2000) notes:

The Air Force has always been 'expeditionary' in the sense that it has taken the fight to the enemy, whether Pancho Villa in Mexico; the German's in World War I Europe; The Japanese in Burma, the Philippines, and the Pacific; or the Nazis and Italian fascists in North Africa and Europe. (p.1)

At the end of World War II, the rise of bipolar superpowers, coupled with the reliance upon defensive, strategic deterrence, led the Air Force to station its personnel as a permanent presence in fixed, forward locations around the globe. To some extent, the culture of the Air Force changed to meet this static deployment strategy. Airmen and their families adapted and accepted as the norm assignments at forward located bases far from the United States. Essentially, these forward locations were in the back yard of the communist threat that they countered. The mission was essentially brought to them. But the expeditionary mindset, where individuals go anywhere and do anything, was not altogether lost.

Post-World War II Deployment. The Composite Air Strike Force (CASF), formed around the time of the Korean War, exists as one of the few exceptions to the stationary, Cold War mindset of the Post World War II Air Force. Nowak (1999) notes the similarities between the emerging EAF and the CASF. Formed in the years after the Korean War, the CASF, "...emphasized rapid deployment of decisive air power

anywhere in the world in minimal time (p. 16)." However, this Cold War anomaly did not last. Nowak attributes the deactivation of the CASF in 1973 to the burden that the Vietnam War placed upon non-nuclear deterrent personnel and aircraft. Expeditionary deployment concepts would not again emerge in such a public form until the 1990s when opposing trends of increased deployment rates and decreased personnel forced a fresh look at the existing Cold War structure.

Deployment Challenges: The Problem

A superimposed representation best illustrates the bind that decreasing personnel strength and increasing deployment commitments make on the Air Force. As Figure 4 depicts, OPSTEMPO (represented as number of personnel deployed) and number of personnel (represented by active duty strength) are based on units of people. Note the scale difference between personnel deployed (0-35,000) and active duty strength (0-600,000). Generally, the data indicate that the Air Force has been tasked to deploy more people since the late 1980s while simultaneously experiencing a decrease in the number of those eligible to be deployed. In the decade since the Persian Gulf War (shown in the figure as the spike in deployment in 1990), deployment levels have steadily increased (Figure 4). For instance, the Air Force filled less than 5,000 deployment positions in 1988 while that number of positions filled in 1999 reached nearly 20,000, a fourfold increase.

Airmen Deploying More. Due to this increase, and assuming a static pool of eligible airmen, any effects caused by deployments either touched a greater proportion of the active duty strength or more often called upon the same individuals who had already deployed. The reality is, fewer and fewer individuals are on active duty to carry the

expanding deployment burden. Eventually, the burden may become too much for those who are left to handle it, and these airmen will begin to leave the Service, despite an increased reliance on reserve forces. Based on these trends, an effective management program, that clearly defines a deployment schedule, is certainly needed to avoid such dire consequences.

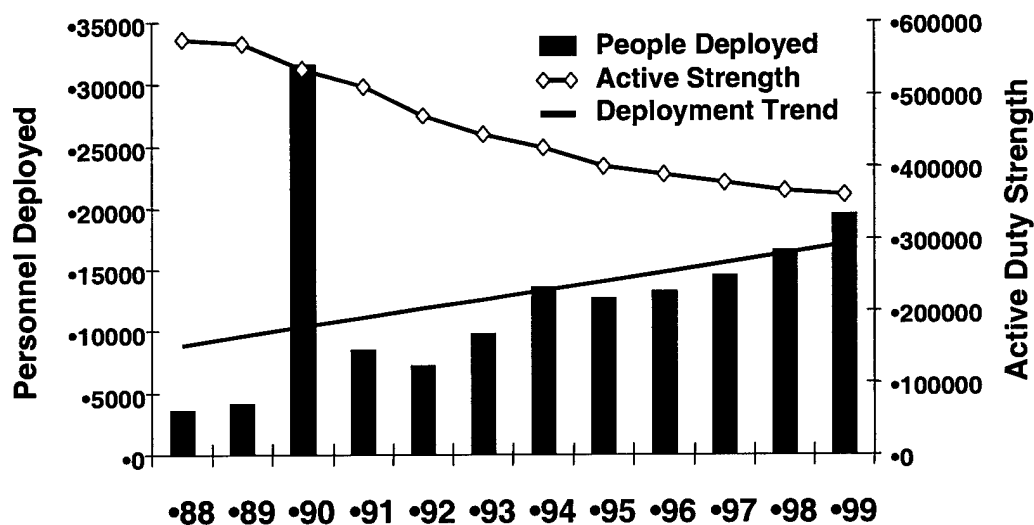

Source: Aerospace Expeditionary Force, 2000

Figure 4. Air Force Strength vs. Deployments, 1988-1999

OPTEMO Increase effects. Before examining the relationship between personnel deployed and active duty strength, a few definitions are required. For the purposes of this study, a deployment is an official duty away from home, where an airman is temporarily assigned to another unit under a new chain-of-command. For the duration of the time deployed, the airman is in effect, a member of that deployed unit. An example of a deployment is a three-month reassignment to a base in a Middle Eastern country

supporting aircraft patrolling one of the no-fly zones over Iraq. In contrast, a Temporary Duty (TDY) is an official duty away from home where there is no change of assignment such as a short school or an industry conference. Although these two duty types are essentially time spent away from airmen's home stations, only deployment time was typically considered a part of OPSTEMPO. Recent efforts in the Air Force have recognized that time spent away from home is difficult whether it is for a TDY or a deployment. In response to this realization, the Service is now tracking the days spent away from home for each individual.

Decreasing Force Strength. The assumption of a static personnel pool is a luxury the Air Force did not enjoy in the post-Persian Gulf War. Exacerbating the increase in deployments was a decrease in active duty strength, effectively reducing the pool from which deployable personnel were drawn. In many cases the same airmen simply deployed more often. Figure 4 illustrates the change of active duty strength relative to deployment rate. Theoretically, these two trends will never meet: the pool of deployment eligible airmen will not exceed the number of deployable positions to be filled. However, any problems resulting from increased strain on an ever-smaller population will most likely amplify as these two trends approach each other. Making this problem even worse, is that not every active duty airmen is eligible to be deployed. Nearly 35 percent of the active duty population hold jobs where they cannot be deployed, such as those involved with acquisition, training, school, or recruiting (Commanders' NOTAM, 2000). These increases in demand for deployable airmen, coupled with a decrease in the number of such individuals, have forced the Air Force into a personnel management bind, one that the EAF will attempt to mitigate.

EAF: The Solution

Defining the Program. An important first step in understanding the EAF concept lies in an understanding of terms. According to the Aerospace Expeditionary Force Center introductory briefing (2000), the EAF concept is defined as, “Our vision for how to organize, train and equip to create a mindset and cultural state that embraces the unique characteristics of aerospace power (n. pag.).” A very similar, but unique term as defined by the briefing is the Aerospace Expeditionary Force (AEF). The briefing characterizes the AEF in the following manner, “An organization of aerospace capabilities that provides tailored forces to meet theater CINC [Commander in Chief] needs (n. pag.).” In much simpler terms, the briefing relates the two concepts with the statement, “EAF is who we are, AEF is what we do (n. pag.).” Thus, EAF is the culture and attitudes of being ready to go anywhere and do anything, while the AEF’s are specifically designated units of individuals and aircraft ready for deployment on a predetermined schedule to fill Air Force requirements.

The EAF Program in Practice. Joint Vision 2020 (2000), the Air Force’s tool to lay the foundation for the service over the two decades following its publication provides an excellent summary of the EAF program:

We have constituted ten deployable Aerospace Expeditionary Forces, or AEFs. Two AEFs, trained to task, are always deployed or on call to meet current national requirements while the remaining force trains, exercises, and prepares for the full spectrum of operations. (n. pag.)

Figure 5 depicts the rotational schedule of the ten AEFs. At any time, each of the AEFs is in one of the stages in the cycle: (a) deployment or on call for deployment (b) recovery from deployment (c) normal training and exercises and (d) preparation for deployment.

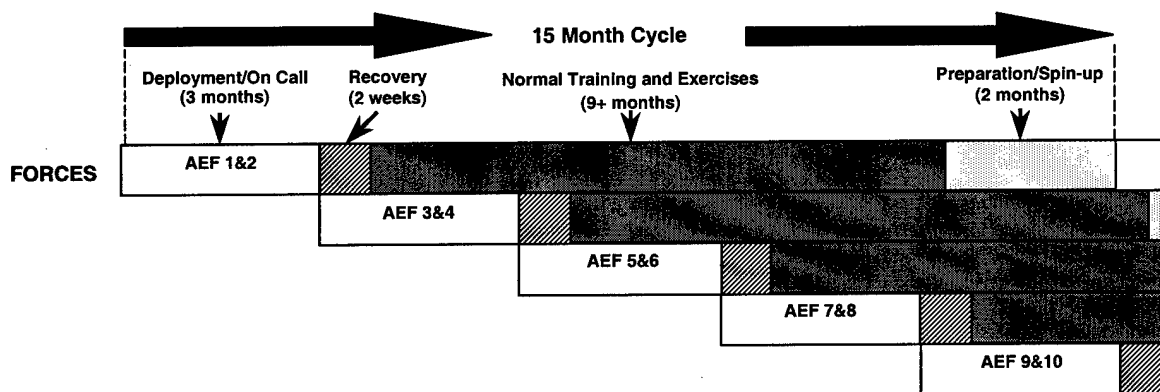

Source: Aerospace Expeditionary Force, 2000

Figure 5. AEF Deployment Cycle

A GAO report, outlines the current use of the AEFs when they are in the “deployment” stage:

Currently, the five contingency operations to be covered by these forces include: (1) Northern Watch in Iraq, (2) Southern Watch in Iraq, (3) Operation Deliberate Force in Bosnia, (4) counter-drug operations in South America and the Caribbean, and (5) North Sea operations in Iceland. Because each pair of forces [the two AEFs in the deployment/on call phase in Figure 2] is greater than these force requirements, not all forces scheduled for deployment will actually deploy. (p. 3)

Thus the time that a unit, and that unit’s personnel spend within the three-month on call phase is typically referred to as a “vulnerability window”, because the personnel may not actually have to deploy. The effect of this program is to place order on a system that prior to it, had little order. Now, all airmen should know exactly where their unit falls in the rotational schedule, and with this information, should know when they will be at home and when they can expect to be away.

Impact on the Individual Airman. What the EAF means for the active duty airmen, is that they should know, with some level of predictability, which three months out of the next fifteen they are vulnerable for deployment. While not necessarily assuring

that individuals will actually deploy, the EAF program provides twelve months of relatively predictable time to organize non-duty related schedules. Airmen may schedule such non-duty events as family gatherings or college courses, avoiding their three-month vulnerability windows.

Intent to Stay: The Outcome

Job Satisfaction and Intent to Stay Theory. Spector (1997) argues that strong evidence exists to suggest that a decrease in job satisfaction leads to a related decrease in retention. The strong correlation between the two constructs is well-founded (Crampton & Wagner 1994; Hulin, Roznowski, & Hachia, 1985). Figure 6 represents a simplified model of the relationship between factors affecting job satisfaction and their relation to retention. Note that Spector (1997) uses the term “intent to quit” while this study views the construct in the positive sense as “intent to stay”. Key to this study, and to the Air Force’s EAF program is the organizational factor of deployment scheduling.

Organizational factors are those outside of the control of the individual. While personal factors, or those that an individual can control, play a role in the job satisfaction/intent to stay relationship, this study focuses on the impact of the organizational factor effects.

Because individual factors are personal, they will tend to be specific to the individual.

The EAF (the framework for this study) is an organizational factor, so discounting personal factors is not a significant problem to examining the effects of the program.

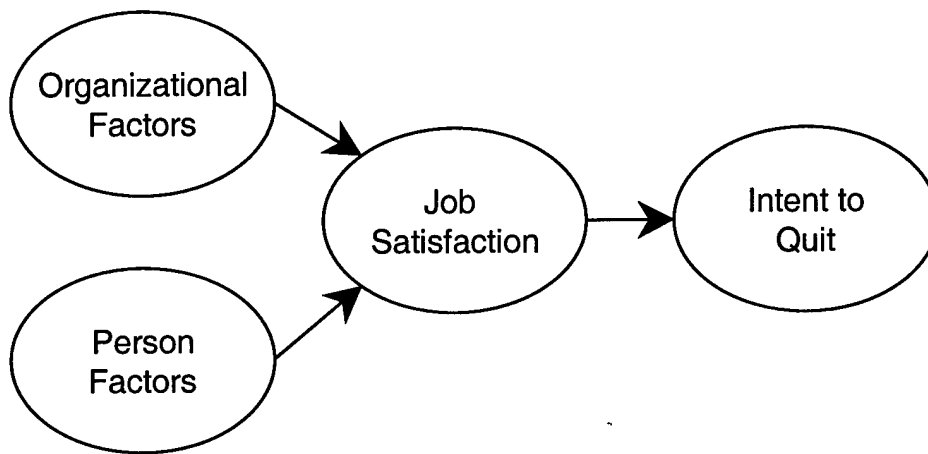

Figure 6. Spector Model of Job Satisfaction/Retention Constructs

Source: adapted from Spector, 1997 p. 64

OPSTEMPO as the Main Retention Factor. Of course, the EAF is only effective if the Air Force manages to retain those individuals that train toward employing under the program so that they can reap the benefits of predictable scheduling. If airmen with expeditionary experience are lost, then the experience that they gain, and in turn, pass along to others is gone forever. Evidence suggests that the deployment schedule is a major determinant for individuals considering whether or not to stay with the Air Force. Sweetman (2000) notes that, “According to surveys and experience, the USAF’s increased operational tempo [OPSTEMPO] and long deployments are major factors in the low retention rates” (n. pag.). While the EAF cannot change national defense policy, it can work to spread the impact of such a policy across a greater number of deployable airmen. The GAO (2000) reports that, “The Expeditionary Concept is likely to achieve its objective of spreading the deployment burden over a large part of the Air Force’s combat forces...” (p. 5). Thus the EAF, as an organizational factor, attempts to control the externally imposed requirement of deployment due to national interest.

Military versus Civilian Retention. Retention is a uniquely poignant problem for the armed services, and the Air Force as well. In the civilian world, a company might fail to retain a junior employee, only to rehire that same employee—years later—with experience gained at a similar company within its industry. Another related possibility outside of the military is the hiring of a mid-level employee with experience gained at another organization. In many cases, when an individual leaves the military, that service-member as well as their experience and training, are lost forever. Service members are, in effect, grown within the system and retained. For the Air Force to effectively manage its personnel, it is important that that Service understands the impact its policies and programs have upon the retention of individual airmen.

Stayers, Separators, and Undecideds. The Air Force has studied retention, loosely defined as the percentage of airmen who would choose to stay with the Service when given the chance to separate, since the mid-1980s (1999 USAF Careers, 1999). The studies typically separated individuals into three groups: stayers, separators, and undecideds based on their intent to remain with the Service. While the stayer category for senior members has shown a moderate decrease since the 1980s, that same category for both junior officers and mid-grade enlisted members has decreased dramatically. Tables 1 and 2, from the Results of the 1999 USAF Careers and New Directions Surveys, indicate these relationships for officer and enlisted categories, respectively. The junior officer and mid-grade enlisted categories are important because it is at this point that career decisions are made. In support of the proposition that these groups are at critical career decision points are the relatively high stayer rates for senior officer and enlisted members. These rates show that those categories of individuals are more than likely to

complete a career to retirement. With retention defined as the key output of this study, the factors that influence intent to stay become important.

Table 1. Air Force Officer Career Intentions, 1986-1999

Rank	Intent (% of total)	1986	1989	1993	1996	1999
O1-O3*	Stay	78	64	72	59	45
	Separate	14	24	14	28	40
	Undecided	8	12	14	13	15
O4-O5**	Stay	97	93	89	89	82
	Separate	1	4	8	9	13
	Undecided	2	3	3	2	5

* - Second Lieutenant through Captain

** - Major through Lieutenant Colonel

Data Source: 1999 USAF Careers and New Directions Surveys, Air Force Personnel Center

Table 2. Air Force Enlisted Career Intentions, 1989-1999

Term of Enlistment	Intent (% of total)	1989	1996	1999
First	Stay	33	29	24
	Separate	51	53	52
	Undecided	16	18	24
Second	Stay	62	50	36
	Separate	36	41	48
	Undecided	8	9	16
Career	Stay	96	89	81
	Separate	3	8	10
	Undecided	1	3	9

Data Source: 1999 USAF Careers and New Directions Surveys, Air Force Personnel Center

Job Satisfaction and Organizational Commitment: The Antecedents

Researchers have identified a concurrent relationship between job satisfaction and organizational commitment on turnover (Lance, 1991; Tett & Meyer, 1993). Turnover in

the prevailing literature is analogous (in an inverse manner) to retention in the military. Job satisfaction has been found to result from individual appraisals of specific job characteristics (Locke, 1976; Smith, Kendall, & Hulin, 1969). Researchers have found an asymmetric relationship: the effect of job satisfaction on turnover intention is greater than the effect of organizational commitment (Lance, 1991; Tett & Meyer, 1993). Furthermore, Lance (1991) suggests that, while affect (a combination of satisfaction and commitment), explains the majority of turnover intent, the constructs of equity and role stress were also determined to, "...play direct roles in determining turnover cognitions" (p. 152). Included in these role stresses: realistic job previews, role overload, role ambiguity, and role conflict—all aspects included in the theoretical model presented in Chapter I. A primary source of such role stress for individual airmen deployed for an extended period is the ambiguity of work versus family demands. Those deployed are asked to fill competing roles as both expeditionary airmen and family members.

Work-Family Conflict: EAF Specific Antecedent

Family as an Explanation. Two critical aspects of an individual's life, nearly mutually exclusive categorizations, are work and family. Frone, Russell, and Cooper (1992-b) argue that each aspect is an important perspective from which a researcher may view an individual. Because this study involves both work and individual factors, both must be included in some manner. Having acknowledged the importance of these factors, I next consider the nature of their relationship to individual behavior.

Role Conflicts. Role conflicts in general exist when the demands of two, mutually-exclusive roles demand limited resources under an individuals control, most likely the resource of time (Kahn, Wolfe, Quinn, Snoek, & Rosenthal, 1964). Role

conflicts are a potential issue for airmen when the interests of an individual as an Air Force member and as a family member come into conflict in their demands for the same segments of time (Frone et al., 1992-b). Conflicts are bi-directional, meaning both the work and the family can suffer negative impacts due to deprived time. Studies have indicated the existence of such a reciprocal relationship (Frone et al., 1992-b). When the negative impact affects the family, the construct is Work-Family Conflict (WFC). When the opposite is true, that the family demands negatively impact the work, the construct is Family-Work Conflict (FWC). In another study, Frone et al. (1992-a) indicate that job stressors and job involvement are positively related to WFC while family stressors and family involvement are positively related to FWC. Because the EAF is a change to the work environment, this study focuses on the first conflict, WFC. Additionally, while work may affect certain family attitudes and behaviors (as with FWC), the outcome variable of the study, retention, necessitates a focus on the relationship in a single direction.

Sociodemographic Effects. The evidence of modifying effects on the impact of WFC is not clear. Frone et al. (1992-b) found no significant differences in WFC outcomes based on sociodemographic categorizations such as marital status and number of dependents. In opposition to these findings, Rothausen (1999) asserts that family is a significant indicator of many work attitudes and behaviors. Thus, the impact that sociodemographic categorizations (marital status and number of dependents in particular) on WFC is not certain. One potential explanation for the inconsistencies in the literature as to the outcome of WFC is the context within which the conflict takes place. For the population of this EAF study, the impact of non-family related sociodemographic factors

should be insignificant as presented by Frone et al (1992-b). However, the impact of family related categorizations (marital status and number of dependents) should modify the effect that the family has on the work behavior of the individual. The reason for this hypothesized relationship is that the separation from family that normally causes stress is typically measured in a population that returns home each evening after work.

Rothausen's (1999) study is a qualitative meta-analysis of thirty-two articles from leading psychology journals and thus, should draw upon a more diverse population of families. Her study should be more inclusive of non-traditional family separation, in particular that experienced by deploying airmen.

Deployment Separations as Absolutes. The separations involved with deployed Air Force personnel are anything but typical when compared to most traditional studies. Rather than being separated by long office hours (the context with which most studies examine WFC), airmen are separated by great distances and must rely on the limited communication tools of the nation where the deployment is taking place. Airmen are afforded limited or costly telephone privileges and must rely on electronic mail (a widely available form of communication while deployed) to maintain communication with family. The reality that deployed airmen are typically located in time zones opposite to those in the US mean that their families are further impaired in dealing with off-duty concerns.

Levels of Dependency as Moderating Factors. Research by Cooke and Rousseau (1984) suggests that the level of family dependency affects the level of physical and psychological strain. The levels of dependency that Cooke and Rousseau (1984) examined included: (1) single, (2) married without children, and (3) married with

children, corresponded to an increase in the appearance of psychological strain, respectively. The psychological strain to which they refer is that of role conflict, otherwise known as WFC. Coupled with the absolute separation discussed above, the potential impact of the presence and number of dependents on the retention of Air Force members is intensified.

The Atypical Family Model. Traditional psychological research in the western world has focused on a definition of a family that is in its essence, ethnocentric. Rothausen (1999) summarizes the manner by which much of the research has defined, and in effect, measured "family". She categorizes the measures into perceptual and quantitative measures. The conventional wisdom defined a typical family as, in the Christian tradition, a married couple with a male as a father figure who works to financially support the family, a female as a mother who stays at home to manage the household, and several children all living under the same roof. The typical definition of family in research is in practice quite atypical. Single parent families, mothers in the workforce, and children who split time between divorced parents are just some of the examples of the move away from the accepted family definition. Rothausen (1999) cites studies indicating that the structure of families, at least in industrialized nations, has significantly changed since the 1940s. The results of her research point to the number or presence of dependents as an acceptable measure of family. In this study, the presence of dependents is used as a family measure.

Predictability: The Theoretical Solution

Trust in the Service. The Air Force provides the training, equipment, and organizational control it deems necessary for airmen to carryout their wartime missions

whether they are to fly an aircraft, to provide battlefield support, or to manage weapons acquisition contracts. For all of these provisions, the organization still relies on the good faith of individuals to carry out their assigned duties when called upon. The Air Force must simply trust that its personnel will act as directed.

Trust in the Commander. Very similar is the reciprocal trust that individuals expect from the organization. Airmen expect that the Air Force has provided them with the appropriate level of training, quality of equipment, and excellence of organizational control required to fight and to win battles. The Air Force recognizes the important role it takes in the relationship. According to a May 2000 message from Headquarters, US Air Force addressed to commanders, "It is the responsibility of unit commanders at all levels to ensure that their people know their AEF deployment window. The predictability and stability offered by the AEF schedule are critical in keeping faith with our people..." (n. pag.). Any breach in either of these two trusts will result in the diminishment and perhaps the termination of the relationship by either party. This mutual trust relationship is commonly referred to as psychological contract theory. Rousseau (1998) defines a psychological contract as, "...the perception of an exchange agreement between oneself and another party (p. 665)." In this case, oneself is the airman and the other party is the Air Force. Rousseau's (1998) assertion that, "Individuals can form psychological contracts that differ in degree from those constructed by the firm's owners and managers...(p. 669)," indicates that the perceptions of individuals as to the terms of the social contract (in this case the airman's interpretation of schedule predictability) are just as important as the firm's (the Air Force's) perception of the contract, and thus warrant study.

Predictability as a Promise. Based on the above mentioned trust relationship, the Air Force has an unwritten deployment contract with its airmen. All eligible members should be able to know, with some level of certainty, when they can expect to be deployed. The EAF program is in part a response to a breach in a feature of this contract (the unpredictable or uncertain nature of the Palace Tenure program) and thus, one of the primary goals of the program is to make airmen's deployment schedules as predictable as possible. Rousseau and Tijoriwala (1998) suggest that such feature-oriented types of psychological contracts are, "...particularly pertinent to our understanding of the process where by means of communicating the psychological contract affect its content and likelihood of fulfillment or violation (p. 690)." One suggested feature is the level of certainty or uncertainty that, in this study, the Air Force will honor the terms of the contract (the deployment schedule) (Rousseau & Tijoriwala, 1998). In its simplest terms, that level of certainty is known as predictability. Webster's Dictionary (1998), in defining the verb "predict", states that, "To predict is usually to foretell with precision or calculation, knowledge, or shrewd influence from facts or experience..." (p. 1523). In the EAF context, I define predictability as an individual, comparative judgment between what the organization tells individuals that their schedule will be, a "promise", and the individuals' feelings toward the organization's actual ability to meet that promise. In a manner of speaking, predictability is a form of trust. In an analogous military situation, Segal, Rohal, Jones, and Manos (1999) discovered similar feelings of a broken promise during interviews of members of an Army PATRIOT missile unit deployed to Korea on short notice. The Chief of Staff of the Army reported that the soldiers assigned to that

unit were promised a stabilized, stateside tour, a promise that the Army broke by deploying them.

Inter-Individual Predictability Interpretation: Fairness. Similar to the Army soldiers in Segal et al.'s study (1999), those airmen who have served under and potentially deployed with an EAF assigned unit will have an experience-based frame of reference with which to interpret the program. Those who have never been subject to the EAF deployment program will make judgments based on several factors: (a) the deployment schedule that they have served under in the past, (b) information about the new system provided by the organization, or (c) the experiences of friends and coworkers. All of these interpretations are experienced-based calculations of fairness as eluded by Webster's definition. Adams (1963), in summarizing equity theory, notes that, "Whenever two individuals exchange anything, there is the possibility that one or both of them will feel that the exchange was inequitable (p. 422)." Thus, individuals compare the fairness of their situation by comparing their own experiences to the experiences of others, shared experience being the good exchanged. Adams (1963) identifies inputs and outputs as key parts of the equity equation. He argues that the inputs to the equity equation should be highly correlated and a similar relationship should exist among the outputs. Inputs, in this case might include the predictability of one's work schedule, or the number of days that an individual spends away from home. Outputs might be perceptions such as WFC, job satisfaction, or organizational commitment. For the Air Force, to identify the predictability feature of the psychological contract, along interpersonal levels, it is important to categorize interpretations of predictability based on both the amount of deployment experience and if that experience is of a personal or second-

hand nature. The effect of EAF altered predictability on groups of individuals based on whether or not they are assigned under the EAF as well as the number and duration of their deployments has the potential to be significantly different. Comparisons of individuals with experiences based on similar, but less extreme separation conditions, namely TDYs, may serve to identify the uniqueness of the effects of predictability on deployment as AEF assigned individuals might compare their deployment experiences with those who are often on TDYs.

Intra-individual Predictability Interpretation: Schedule Conflict. Not only do individuals make comparisons with their peers; they make comparisons within themselves. People manage their lives with some level of planning or scheduling. Many sub-schedules can cause conflict in an individual's overall schedule. The two primary schedules of interest with the EAF goals in mind are work and family schedules. For the most part, these two schedules are mutually exclusive in their demands upon an airman's time. Airmen and their families expect to be separated during normal work hours and to have time together after such hours are over. A deployment makes the latter use of time impossible. The February 2000 issue of *Armed Forces Journal International* quotes Air Force Chief of Staff, General Michael Ryan, with respect to predictability's proposed effect on conflicting schedules:

We put a big emphasis on making sure our people were afforded the opportunity to have some predictability in their lives. It [the EAF program] allows them to know when they'll be away, and when they'll be home, and puts some structure in their lives—not just their professional lives but their private lives, their family lives. (p. 56)

As Ryan suggests, this schedule conflict is akin to role conflict. An individual's role as a family member or home station worker exists in conflict to that individual's role as a

deployable airman. The primary medium in the EAF predictability relationship, the medium through which individuals make comparisons, is the schedule of activities that the individual completes. More precisely, it is a conflict of the deployable schedule with the family schedule. When these two schedules conflict, the individual either retools one of the schedules to avoid the conflict, ignores the stress involved, or allows that stress to manifest itself in any one of numerous outcomes. Because predictability, in the absolute sense of deployment, is similar to role conflict, it should be related to similar constructs. These are typically job satisfaction, organizational commitment, and intent to quit the organization (Lance, 1991; Tett & Meyer, 1993). Thus, these role conflict outcomes should manifest themselves similarly with the schedule conflict of predictability. Furthermore, job satisfaction and organizational commitment, especially within the context of intent to quit, are correlated by an asymmetrical, reciprocal relationship (Lance, 1991). Predictability has the potential to impact another form of role conflict, defined earlier as WFC. By creating an absolute separation between an individual and that individual's family, the separations involved with WFC are carried to an extreme state. Thus, the existence of predictability, or a lack of schedule conflict, should reduce the appearance of WFC.

Evidence of Predictability in the Military Context. Segal et al. (1999) studied the differences in outcomes for two Army PATRIOT units, the 2-7 Air Defense Artillery (ADA), deployed to Korea on short notice for a duration of six months and the 1-43 ADA, deployed as the first unit's replacement. The 2-7 ADA had been promised a two-year, stabilized, stateside tour prior to its short notice deployment. The 1-43 ADA was notified of its schedule at the same time as the 2-7 ADA was, essentially giving them a

six-month advance notice. Interviews and comments of the 2-7 ADA indicate that, "The Army was breaking a promise to stabilize them at Fort Bliss [their stateside post] by asking them to deploy more frequently than other PATRIOT battalions..." (p. 164). These comments reinforce the issue of comparative fairness as a measure of satisfaction with a deployment program. In terms of deployment, schedule predictability is that measure. Segal et al. (1999) further relate the potential broken promises of predictability with retention in stating:

In general, on the basis of our data, it is reasonable to hypothesize that, in contrast to the 1-43 ADA, frequent deployments over a number of years in the 2-7 ADA, and in particular these soldiers' unanticipated deployment to Korea, have contributed to demoralization, to a decrease in career intention, and to demands on families that are likely to increase the negative impact on retention. (p. 166)

Due to the defensive nature of the PATRIOT missiles, those units are often deployed at the same bases as Air Force units in locations such as Korea and the Persian Gulf. Thus, the deployment similarities between Army PATRIOT units and Air Force unit indicate that a similar relationship may exist for those in the air service.

Evidence of Predictability in the EAF. The EAF is the Air Force's attempt to combat a lack of predictability. Qualitative examples of an EAF induced sense of predictability abound. Major General Carrol H. Chandler, Air Staff's EAF Implementation Director, reported positive feedback on the EAF and predictability during the redeployment of the first truly complete Aerospace Expeditionary Forces, those including support as well as operational personnel. Chandler characterized the feedback in the following manner. "Most is positive. There have been entire units reporting back that the predictability of the AEF process is great!" (Schnaible, 2000, n. pag.). The Air Force has also recognized an increase in the quantitative measure of

predictability, prior notification of deployment in number of days, over the EAF's first year of existence by tracking the statistic.

Construct Relationships: The Model

The literature supports the notion that intent to stay, as an outcome, is influenced by both job satisfaction and to a lesser extent, the related construct of organizational commitment. Job satisfaction and organizational commitment are in turn, theoretically influenced by WFC. A predictable schedule should decrease conflict that individuals have between their work and families (WFC). The EAF program has the potential to decrease the importance of the predictability—WFC relationship that airmen experience. A lack of dependents also has the potential to moderate the predictability—WFC relationship. Figure 7 serves as a graphical representation of this theory. If these relationships hold true then the following hypotheses should also hold true, and warrant testing as set forth in Chapter III, Methodology:

Hypothesis 1: *Predictability, through a combination of intermediate constructs, has a positive impact on intent to stay.*

Hypothesis 2: *Respondents who are supporting dependents will show a stronger relationship between predictability and work-family conflict than those without dependents.*

Hypothesis 3: *Respondents reporting assignment to an AEF will show a stronger relationship between predictability and work-family conflict than those not reporting AEF assignment.*

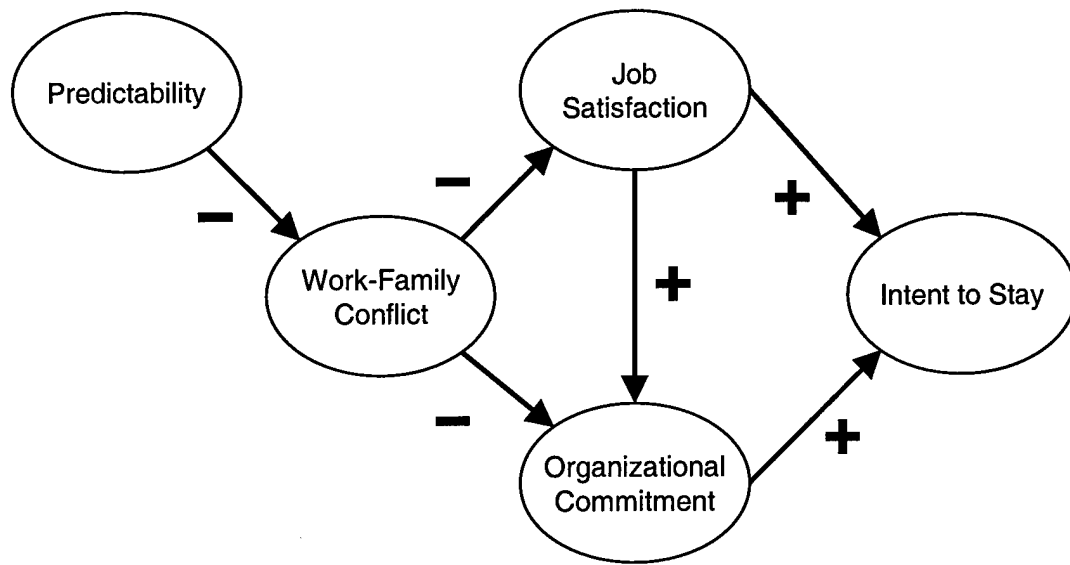

Figure 7. Model of Construct Relationships

III. Methodology

Design

The Research Theory. The study consisted of a cross-sectional survey of personnel in the active duty United States Air Force to determine the construct relationships involved in the research questions. The lack of researcher-initiated intervention classifies this approach as purely observational (Dooley, 1995). The study was based on the hypothesized causal relationships among the constructs indicated by past research. The two requirements for a design to indicate causality are that the dependent and independent variables are associated (or correlated) and that the independent variable happens before the dependent variable (Dooley, 1995). While order is difficult to determine between the study constructs and the EAF program, the second requirement, association, is less difficult. The limitations in terms of causality will inhibit the ability of this study to determine causality, but further research or related studies should eventually fill in this weakness. The study used multiple group Structural Equation Modeling (SEM), detailed later, to examine both correlation and order among constructs.

The Data Collection Tool. The medium for the study data collection was a web-based survey questionnaire. While difficulties related to respondents' interpretation of items within surveys exist, the worldwide dispersion of subjects renders a telephone or face-to-face survey impractical (Dooley, 1995). A web-based technique was chosen over a mailed survey to reduce input error and gather data more efficiently. Senior defense leaders feel that the subjects, military members, hold the constructs of interest in this

study as important (Garamone, 1999). Because of the level of importance individuals placed on the study's relevant issues, a high level of cooperation, and thus a high response rate were expected. In terms of validity, Buchanan and Smith (1999) found in a comparison of two samples, one completing a web-based version of a psychological survey, and another completing a paper and pencil version, that the two had, "...similar psychometric properties...and compared favorably as a measure..." (p. 125). Edwards, Rosenfeld, Booth-Kewley, and Thomas (1996), in a cross-survey analysis undertaken with a contextually similar sample to this study's (US Navy surveys), found that "...computer and paper surveys generally yield equivalent results" (p 309). Perhaps most critical to this study are the covariances amongst constructs due to the heavy reliance upon them by the SEM technique. Stanton (1998) indicates that, in a comparison of two samples, one completing an internet survey and the other a paper and pencil survey, that a, "...covariance analysis simultaneously conducted in both samples indicated similar covariance structures among the tested variables" (p.709). Thus the web-based method is at least as valid as the paper method.

Population and Sampling Information

Sampling Technique. The most effective manner with which to achieve probability sampling is random sampling (Dooley, 1995). The basic units, or elements, for the study were chosen from the population of military personnel in the active duty United States Air Force at the time of the survey. A random sample of the population was generated based on the sampling frame of the Air Force Personnel Center's current staff roster for the entire service. Due to the high level of accession and loss, and the limitations of the Air Force personnel accounting system, an actual enumeration of the

population (a perfectly representative survey method) would prove impractical.

Elements were drawn from the population in three stages using probability sampling in a stratified manner.

Stratified Sampling. Jaccard and Wan (1996) suggest that sample sizes for the statistical path analysis of multiple group SEM are desired at 100 samples per group, but are acceptable at levels of 75 per group. In order to assure adequate sample sizes, a random sampling, based on a desired group size of 100 and demographically comparable stratifications (assignment under EAF program, dependent status), was completed. Due to the level of importance individuals placed on the study's relevant issues, a high level of cooperation was expected thus the expected response rate was set at 50%. The group sample sizes in Figure 8 consider that rate.

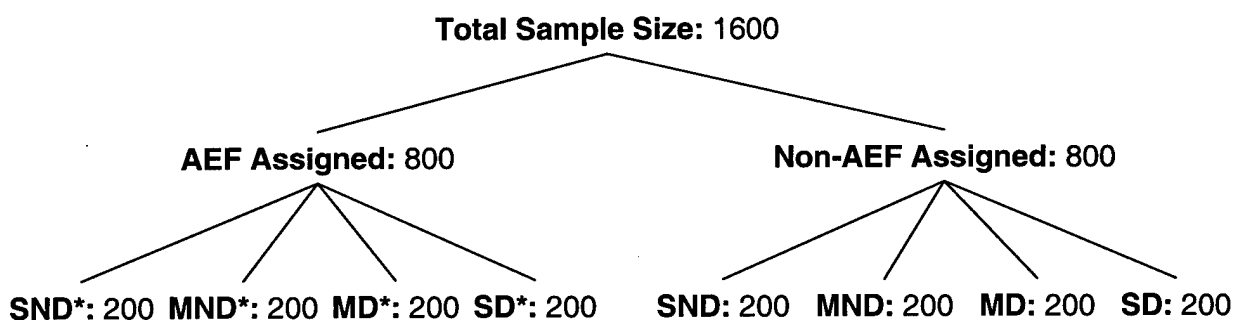

* - note: SND = single, no dependents; MND = married, no other dependents; MD = married & other dependents; Single, dependents; 200 group sample size accounts for expected response rate of 50%

Figure 8. Overall Sample Size Calculation

Sampling Stages. Sampling was completed in three stages summarized in Table 3. The first stage was completed to reduce the population, approximately 300,000 active duty Air Force members, to a manageable sample size. Ideally, the sample would have

been chosen based on the eight stratifications indicated in Figure 8. Two limitations with the Air Force personnel database caused substitutions to be made.

First Database Limitation. First, the Air Force does not currently track whether an individual is assigned to an AEF due to the rotational nature of personnel, rather, it tracks positions and units assigned to an AEF. Personnel typically change unit assignment once every two to three years so the position and unit tracking makes better sense. However, the majority of AEF units fall under the Air Combat Command (ACC) and Air Mobility Command (AMC) (e.g. forty ACC and AMC units out of forty assigned to AEF 1, Cycle 2, with a deployment window of 1 Dec 00 – 28 Feb 01). Additional units are sometimes drawn from United States Air Forces, Europe (USAFE) and Pacific Air Forces (PACAF), but this is less common. Therefore, individual assignment to ACC and AMC was used as a proxy for AEF assignment.

Second Database Limitation. The second limitation with the personnel database is that only one stratification could be used to sample at a time. Therefore, a random sample of Air Force members was used, with the expectation that the natural distribution of marital and dependent status should provide an adequate group sample size. The second stage of sampling was completed to ensure that there would be adequate group sizes based on marital status. The first stage sample was sorted by marital status and four second stage samples were randomly generated between married and single individuals. Widowed and divorced personnel were included in the single samples. At this point, potential respondents were contacted. The final stage was conducted to boost the sample size for single individuals after it was apparent that the single stratifications would not meet the per group minimum of 75 suggested by Jaccard & Wan (1996). Additional

single respondents (from those not already chosen from the stage one sample) were randomly chosen and then contacted.

Table 3. Sampling Stage Summary

Stage		ACC and AMC*		All other Commands	
First	Stratification	800		800	
	Size by Stratification				
Second	Additional Stratification	Single	Married	Single	Married
	Size by Stratification	400	400	400	400
Third	Additional Stratification	Single		Single	
	Size by Stratification	100		100	

* - Air Combat Command (ACC), Air Mobility Command (AMC)

Response Rate. Table 4 summarizes the response rate for the sample accounting for undeliverable messages. The method of contact, an e-mail message directing potential respondents to log into a web-site containing the study survey is located along with the survey at Appendix A. E-mail addresses were generated through a combination of an incomplete Air Force e-mail listing along with a generated approximation for the remainder of addresses based on Air Force standard address format. Respondent-local e-mail server errors and inconsistencies in local address formats were the most likely cause for the undeliverable messages.

Table 4. Response Rate Summary

	Number of Contacts/Responses
Initial Contact Messages	1600
Additional Contact Messages	200
Undeliverable Messages	(436)
Non-Responses	(980)
Unusable Responses	(22)
Effective Sample Size	362

Nature of the Data

Data were collected as indicated in the sample survey at appendix A. Data relating to the theorized constructs was collected in a quantitative manner based on a Likert-style scale with seven response options, including a neutral option to avoid forcing effects. Items for measuring each construct under consideration were chosen by modifying pre-validated measures to the study environment of the Air Force. The inclusion of validated measures aids in the avoidance of random error due to poor item construction (Dooley, 1995). The survey was constructed such that questions appear in a random order where possible to avoid potential order effects (Dooley 1995).

Construct Measures

Each measure's items were framed to match the context within which the survey and the subjects exist. Adjusting measures to meet contextual issues is a common practice. Cammann, Fichman, Jenkins, and Klesh (1983) present a strong case for the validity of applying context to measures, especially when using individual responses to measure constructs pervasive throughout complex organizations e. g., the Air Force and the EAF paradigm (see also Schmit, Ryan, Stierwalt, & Powell, 1995). The authors argue:

This strategy [contextualization] allows us to adapt our questionnaire to the language and circumstances of any particular organization without losing comparability across organizations where the same issues are important. (p. 74)

Specific alterations are explained in the discussion of each measure.

EAF Induced Predictability. Predictability, in this case induced by the EAF, is measured with four items adapted from a model of role ambiguity presented by Rizzo,

House, & Lirtzman (1970) and four newly created items for the study for those respondents assigned to an AEF. For those not assigned to an AEF, two Rizzo et al. (1970) items and three newly created items are used as a measure, respectively. The items for those reporting assignment to an AEF are put in the context of the AEF while those items for non-AEF assigned individuals are specific to the predictability of their lives in the Air Force in general. For the borrowed items, the authors indicate that ambiguity is due to a lack of information concerning the role. This study operationalized the role as that of a deployable Air Force member and the potential lack of information concerning the EAF deployment schedule, and thus, the time spent away from one's family. Despite the ties to role ambiguity, the construct of predictability is still somewhat vague. Due to its appearance in virtually every documented reference to the individual benefits of EAF, and the lack of a clear definition, the term "predictability" may have a slightly different meaning between subjects. To allow for individual subject interpretation, the newly developed items asked in straightforward terms if the subjects feel that the construct is applicable to them. A representative item reads, "Explanation is clear as to my AEF schedule."

Work Family Conflict. A measure of WFC based upon the three-factor model initially presented by Stephens and Sommer (1996) was used for the study. The Stephens/Sommer model consists of fourteen items measuring: time, "...a consequence of competition for an individual's time from multiple role demands" (four items); strain, "...when role stressors in one domain induce physical or psychological strain in the individual..." (four items); and behavior, "...when patterns of behavior appropriate to each domain are incompatible..." (six items). The authors conducted both an exploratory

Table 5. Stephens & Sommer WFC Confirmatory Factor Loadings

Item	Time	Strain	Behavior
1. My work keeps me from my family more than I would like.	.80		
2. My work takes up time that I feel I should spend with my family.	.85		
3. The time I must devote to my job does not keep me from participating equally in household responsibilities and activities.	.58		
4. I generally seem to have enough time to fulfill my potential both in my career and as a spouse and parent.	.54		
5. I often feel the strain of attempting to balance my responsibilities at work and home		.80	
6. Because my work is so demanding, I am often irritable at home.		.71	
7. The demands of my job make it difficult for me to maintain the kind of relationship with my spouse and children that I would like.		.88	
8. The tension of balancing my responsibilities at home and work often causes me to feel emotionally drained.		.73	
9. The problem-solving approaches I use in my job are effective in resolving problems at home.			.46
10. The things I do that make me effective at work also help me to be a better parent and spouse.			.56
11. What works for me at home seems to be effective at work as well, and vice versa.			.79
12. I am not able to act in the same way at home as at work.			.80
13. I act differently in responding to interpersonal problems at work than I do at home.			.60
14. Behavior that is effective and necessary for me at work would be counterproductive at home			.70

Source: adapted from Stephens & Sommer 1996, p. 484

and confirmatory factor analysis to finalize the items. In the confirmatory factor analysis, each item loaded to at least a .46 level with most falling in the range of .70-.85 (see Table 5). Stephens and Sommer found inter-item reliabilities (Cronbach's alpha) of .80 for behavior, .77 for strain, and .74 for time. The items were altered in two ways to improve the applicability of the measure in the minds of the subjects. First, references to the traditional nuclear family were replaced with wording that allowed the subject to determine whom they consider a family member or dependent, and thus a player in the WFC arena. For example, the original Stephens/Sommer item reads, "I generally seem to have enough time to fulfill my potential in both my career and as a spouse or parent." To

avoid errors due to subjects with non-traditional families, the item now reads "I generally seem to have enough time to fulfill my potential in both my career and as a family member." Second, the items were altered to account for the absolute subject/family separation that an EAF deployment necessarily imparts. The original item reads, "Because my work is so demanding, I am often irritable at home." While this was certainly plausible for non-deployment situations, it would be impossible for a subject to be "at home" while deployed. Thus, the item reads, "Because my work is so demanding, I am often irritable with my family" to account for the absolute subject/family separation during a deployment. Because of the unique aspects of military life, the respondents were asked to answer each WFC item from two frames of reference shown on the survey itself as a pair of side-by-side scales. The first frame was designated as "feelings while NOT deployed" and the second as "feelings while deployed." The purpose of this adaptation is twofold. First, the subject is forced to differentiate between WFC experienced as a result of non-deployed life in the Air Force and that as a result of deployments under the EAF paradigm. Second, the data from the non-deployed section may be used as a control to compare the relationships between levels of WFC at home and while deployed.

Job Satisfaction. Job satisfaction was measured using a portion of the Michigan Organizational Assessment Questionnaire (MOAQ). Cammann et al. (1983) constructed the MOAQ on a modular basis, with each model subjected to a split-half, principal-axis factor analysis using a varimax rotation. The chosen measure for this study consists of three items. While not reporting an exact sample size, the authors guarantee that the sample for each module contained at least 400 individuals, drawn from at least three

distinct organizations. The MOAQ researchers revised the items and conducted a second factor analysis. Once complete, the authors performed a reliability analysis, using Cronbach's alpha. For the job satisfaction measure, Cammann et al. (1983) reported an alpha of .77.

One of the three items was altered, again with the purpose of matching context as argued above. The original MOAQ measure, "In general, I like working here" reads in this study's survey, "In general, I like working in the Air Force." This change avoids the ambiguity to which the word "here" begs. Potential subject confusion might follow the lines of, "here at my permanent station?", "here in my unit?", or "here in my deployed location?" The survey now specifies that the satisfaction is related to the Air Force in general. To avoid potential response bias, the items for job satisfaction appear in the survey in a random order with those for the constructs of retention and affective commitment in a section titled "Attitudes About the Organization".

Organizational Commitment. The study measures the affective component of attitudinal commitment to an organization based on a scale first suggested by Allen and Meyer (1990) in a study of 256 subjects in three separate organizations. The items for affective organizational commitment appeared randomly throughout the Allen & Meyer (1990) questionnaire amongst items measuring other dimensions of commitment. A principal axis factoring method using a varimax rotation verified that the affective commitment items loaded against the same, mutually exclusive factor. An inter-item reliability study produced a Cronbach's alpha of .86. As with the previous measures, the words "Air Force" are substituted for the word organization in most of the affective commitment items.

Intent to Stay. A measure of intent to stay was adapted from a study conducted by Wayne, Shore, & Liden (1997) of 1,413 salaried employees with tenure of at least five years in a United States-wide corporation. A second survey of the same measure included 289 managers from the same company. For the five item scale, the authors obtained an inter-item reliability rating (Cronbach's alpha) of .89. As before, several items were tailored to meet the contextual reality of this study's sample by placing the words "Air Force" where prompted by the authors to insert "name of company." A reverse score of the items adjusted the measure to one of intent to stay rather than intent to quit.

Dependent Status. A dual item measure of dependent status was created. The first item measured the marital status of the subject in the following manner: "Are you currently married to a spouse you consider a dependent?" The dependency term allows for situations in which a couple is still legally married, but have been separated for an extended period of time and thus lack a true dependency relationship of the kind included in the WFC construct. Following the logic that defining a dependent relationship was something that subjects must answer for themselves, the second item included open-ended wording to allow for the possibilities of any dependency relationship, inside or outside of the traditional nuclear family. The item asked subjects to list the number and ages of dependents along with their relationship. This wording allowed for the inclusion of a dependency relationship such as a disabled parent living near and depending upon the subject.

AEF Status. As described in the section on sampling, the Air Force does not track which particular individuals are assigned to the AEF. Rather, a unit is tasked for a certain

number of positions based on job specialty. Also mentioned earlier, it is the responsibility of the unit commander to join individuals with those positions. Thus, the most appropriate manner with which to gauge if an individual is assigned to an AEF was to ask, as was the case with this study's survey.

Statistics

Several statistical analyses of the data, based on the theoretical construct model offered in Chapter 2 and the related hypotheses were performed in accordance with the multiple-group SEM techniques outlined by Jaccard and Wan (1997) and the computer software LISREL. SEM is a technique that compares a theoretical association of constructs to that of actual data. The decision rule for acceptance of a model is a goodness of fit indicator, most typically the chi square statistic, based on a comparison of an actual covariance matrix to a theoretically predicted one. In multiple-group SEM, two steps are required. First, the model must prove acceptable for the entire sample of all groups. Assuming an acceptable model across groups from step one, step two requires a group by group comparison in the form of a differential in fit indices. The hypothesis that groups differ in their underlying latent construct models is supported if the differentials prove statistically significant. The measures gathered above will serve as indicators, or observed variables in the model, represented by rectangles in Figure 9. Theoretically assumed latent variables underlying the observed variables are represented by ovals in Figure 9.

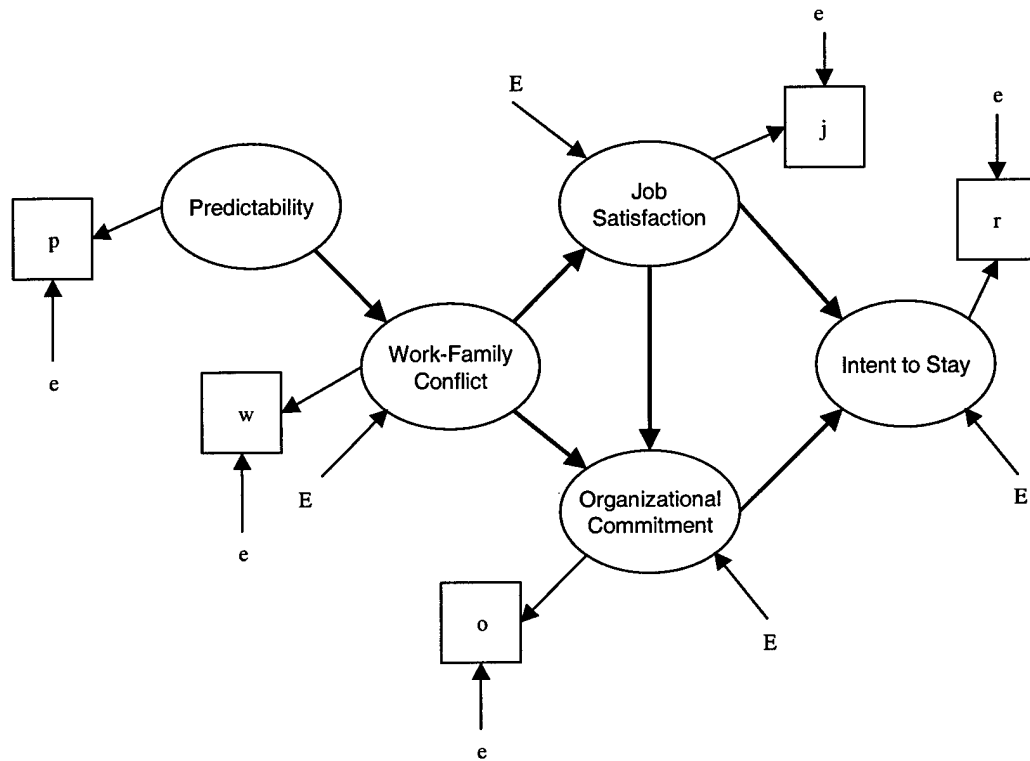

Figure 9. Structural Equation Model of Construct Relationships

IV. Analysis

The following chapter evaluated data collected via the web-based survey. The first level of examination was a general factor analysis. The next level of analysis was focused on descriptive statistics. The next level was a confirmatory structural equation modeling analysis aimed at determining the most likely relationships between the measured variables and their latent constructs. The next step included MANOVA and regression analyses for demographically categorized sub-groups of the entire study sample. The next analysis expanded upon the revised full-sample path model by examining the impact on model fit between the sub-groups where differences are suggested in the MANOVA and regressions. The final examination looks at the impact upon model fit with the addition of objective measures of deployment.

Factor Analysis

To add to the validity of the chosen measures, a general factor analysis of the measure items was conducted. Predictability measures were not included due to the differences in item wording between the AEF defined groups. Retention, the outcome variable, was also not included. A direct oblimin, principal axis factor analysis was conducted. Table 6 illustrates the factor loading of each of the items. In general, the items loaded on factors as expected. Job satisfaction item 3 (JOB_SAT3) primarily loaded against the factor grouping the organizational commitment items, but still exhibited cross-loading onto the job satisfaction factor enough to warrant retaining the item. While WFC loaded against three factors as did the Stephens & Sommer (1996) model referenced in Chapter 3, the items did not break apart in the same manner. Since

the overall measure is reliable, the items were grouped into one measure for the remainder of the analysis. Overall, the factor breakout along with the acceptable reliability statistic values indicate measures that are valid.

Table 6. Factor Analysis Loading

Item/Survey Question Number*	Factor				
	1	2	3	4	5
O/6o	-.826				
O/6l	-.797				.525
O/6f	-.786				
J/6n	-.777				.552
O/6e	-.717				
O/6d	-.713				
O/6c	-.699				
O/6j	-.457				
O/6i	-.406				
W/5d		.847			
W/5a		.824			
W/5h		.803			
W/5b		.799			
W/5k		.667		-.529	
W/5e		.642		-.568	
W/5g		.581			
W/5j		.576			
W/5c			.733		
W/5f			.706		
W/5m			.550		
W/5l				-.767	
W/5i				-.717	
W/5n				-.663	
J/6a					.883
J/6g					.818

*-Questions located in Appendix A: Survey Package;
Direct Oblimin, Principal Axis rotation

Descriptive Statistics

The descriptive statistics and correlation among variables used in the analysis are summarized in Tables 7, Descriptive Statistics and Correlation for All Constructs; Table 8, Descriptive Statistics by Demographic Across All Measures; and Table 9, Demographic Comparison of Sample to Population. Figures 10 and 11 compare the

officer and enlisted rank percentage breakdown of the sample to that of the Air Force. Descriptive statistics for each survey item are included in Appendix B. The correlation relationships shown in Table 7 confirmed that the direction of the relationships amongst measures met the theoretical relationships established in Chapters I and II. For example, the measure for predictability was negatively correlated to that for work and family conflict with a statistic value of $-.441$ ($p < .01$). Similarly, the measure for job satisfaction was correlated to that for intent to stay with a value of $.666$ ($P < .01$). Of interesting note is that all constructs were significantly correlated, indicating that a more sophisticated method of analysis (above that of simple regression, for instance) was necessary to examine relation amongst the constructs. Structural equation modeling proved to be the analytical method most suited for examining the construct relationships.

Table 7. Descriptive Statistics and Correlation for all Constructs

Measure	Descriptives		Pearson Correlation				
	Mean	SD	1	2	3	4	5
1. predictability	4.35	1.47	(.91)**				
2. work-family conflict	4.11	1.08	-.441*	(.89)			
3. job satisfaction	5.22	1.44	.356*	-.452*	(.82)		
4. organizational commitment	4.65	1.11	.280*	-.376*	.659*	(.87)	
5. intent to stay	4.42	1.70	.285*	-.386*	.666*	.625*	(.87)

N = 362, *-- $p < .01$ (two-tailed), **--reliability estimates in parentheses along diagonal = Chronbach's alpha

Table 8. Descriptive Statistics by AEF & Dependent Status Categories Across All Measures

AEF Status	Dependent Status	Statistic	Measure					
			P**	WFC Home	WFC Away	J	O	I
Yes	Yes	n*	104	102	75	104	104	104
		Mean	4.016	4.338	4.515	5.042	4.576	4.085
		Std. Deviation	1.471	1.109	.979	1.435	1.153	1.697
		Skewness	-.151	-.290	-.417	-.660	-.417	.018
		Kurtosis	-.539	.066	1.377	.095	.218	-.769
	No	n*	67	67	48	67	67	67
		Mean	4.043	4.229	4.263	5.060	4.538	4.475
		Std. Deviation	1.371	.910	.914	1.603	1.144	1.805
		Skewness	-.393	-.022	-.326	-.763	-.001	-.405
		Kurtosis	-.139	1.095	1.512	-.177	-.741	-.774
No	Yes	n*	120	119	79	120	120	120
		Mean	4.737	4.018	4.060	5.533	4.850	4.677
		Std. Deviation	1.461	1.109	.969	1.229	1.067	1.612
		Skewness	-.476	.016	-.217	-1.307	-.688	-.404
		Kurtosis	-.446	.036	1.597	2.365	-.029	-.647
	No	n*	71	70	44	69	69	69
		Mean	4.493	3.803	3.851	5.106	4.544	4.446
		Std. Deviation	.71	1.068	.880	1.563	1.075	1.690
		Skewness	-.399	-.047	-.682	-1.209	-.434	-.533
		Kurtosis	-.397	.570	-.017	.704	-.212	-.691

*--Pairwise statistic calculation, **--P=Predictability, WFC=Work-Family Conflict, J=Job Satisfaction, O=Organizational Commitment, I=Intent to Stay

The demographic breakdown depicted in Table 9 shows that, in general, the study sample matched the make-up of the population across the demographics of AEF status, marital status (a substitute for dependent status), and gender. A significant skew towards officers was also noted (81 percent of the sample, 62 percent of the Air Force population).

Table 9. Demographic Comparison of Sample to Population

	Demographic			Total
	AEF	Non-AEF	Unknown	
Number	171	191	0	362
Sample	47.24%	52.76%		
Air Force*	33.33%**	66.66%**		
	Married	Single	Unknown	Total
	Number	267	93	2
Sample	73.76%	25.69%	0.55%	
Air Force*	61.68%	38.32%		
	Officer	Enlisted	Unknown	Total
	Number	128	226	8
Sample	35.36%	62.43%	2.21%	
Air Force*	19.44%	80.56%		
	Male	Female	Unknown	Total
	Number	282	74	6
Sample	77.90%	20.44%	1.66%	
Air Force*	81.08%	18.92%		

*Adapted from Air Force Personnel Center Database as of 31 Dec 00, ** Estimate

Rank Demographics. Figures 10 and 11 examine enlisted and officer sub-groups by rank. All airmen are either an officer or they are enlisted. Figure 10 shows that the distribution of enlisted airmen across rank for the sample is distributed in higher proportion to the more senior ranks than the Air Force population. Figure 11 shows the same analysis for airmen who are officers. In the officer comparison, the sample generally matches the distribution for the Air Force population.

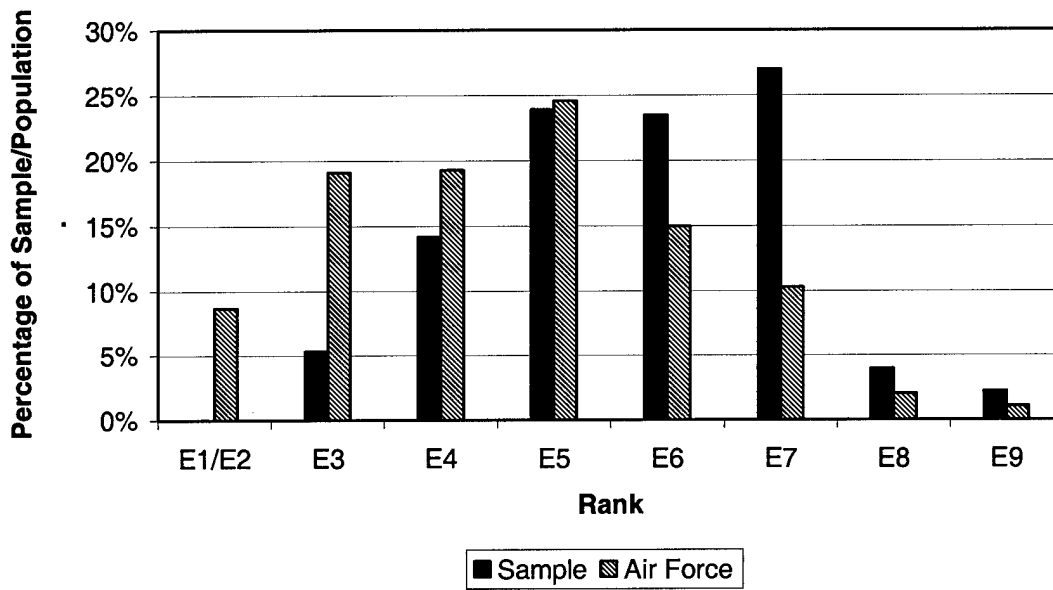

Figure 10. Enlisted Breakdown by Rank Percentage

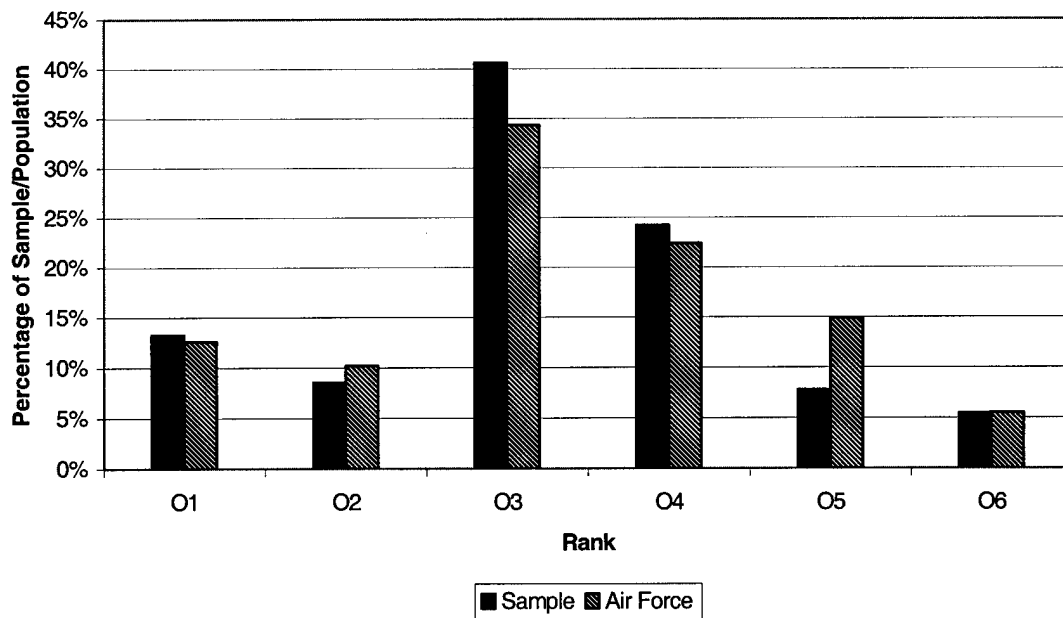
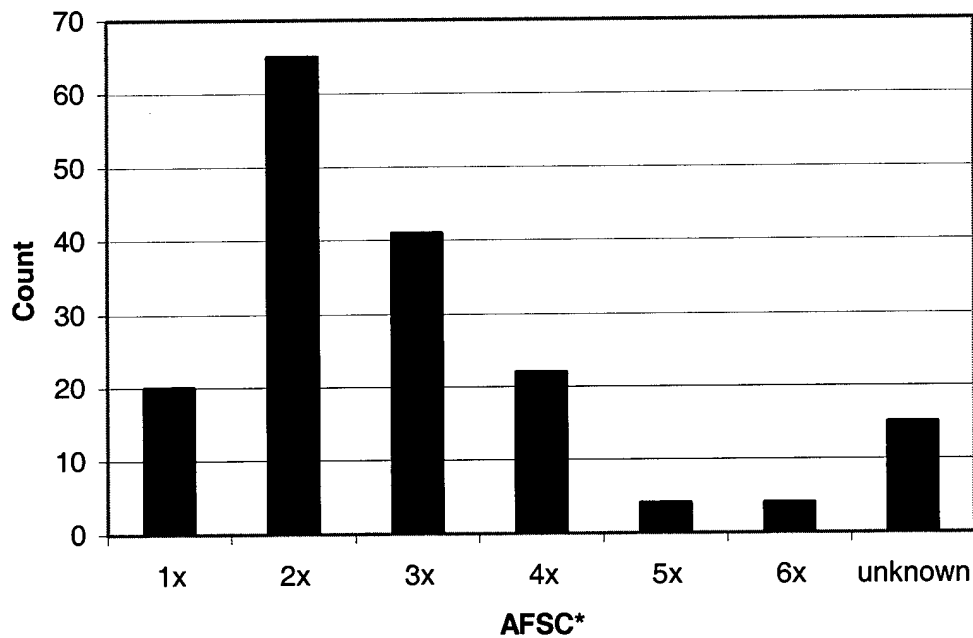

Figure 11. Officer Breakdown by Rank Percentage

AFSC Demographics. Figure 12 illustrates the breakdown by Air Force Specialty Code (AFSC) of the AEF group (n = 171). AFSC's are a categorization of the job type that airmen are assigned to for the length of their careers. The first number serves as the most basic categorization while additional numbers (represented by "x"), further break down each job type. The following is a summary of the major categories: 1x = operations, 3x = support, 4x = support, 5x = support, 6x = acquisition. While the majority of the AEF group fell under the operations category (65), AEF group members reported AFSCs in all major categories (1x = 20, 3x = 41, 4x = 22, 5x = 4, 6x = 4, unknown = 15).



*--AFSC (Air Force Specialty Code), 1x=operations, 2x=support, 3x=support, 4x=support, 5x=support, 6x=acquisition

Figure 12. Breakdown by Air Force Specialty Code, AEF Sub-Group

MAJCOM Demographics. Figure 13 illustrates the breakdown by assignment to Air Force Major Command (MAJCOM) for the AEF group (n = 171). MAJCOMs are the largest categorizations into which the Air Force is organized. Commands included in those reported by the AEF group were: Air Combat Command (ACC), Air Mobility Command (AMC), Air Education and Training Command (AETC), Pacific Air Force Command (PACAF), Air Force Materiel Command (AFMC), and Air Force Space Command (AFSC—note, this is also the acronym for Air Force Specialty Code). The majority of the AEF group reported assignment to ACC (82) and AMC (40) as expected. The other commands were represented as follows: AETC = 17, PACAF = 13, AFMC = 12, AFSC = 1, and unknown = 6.

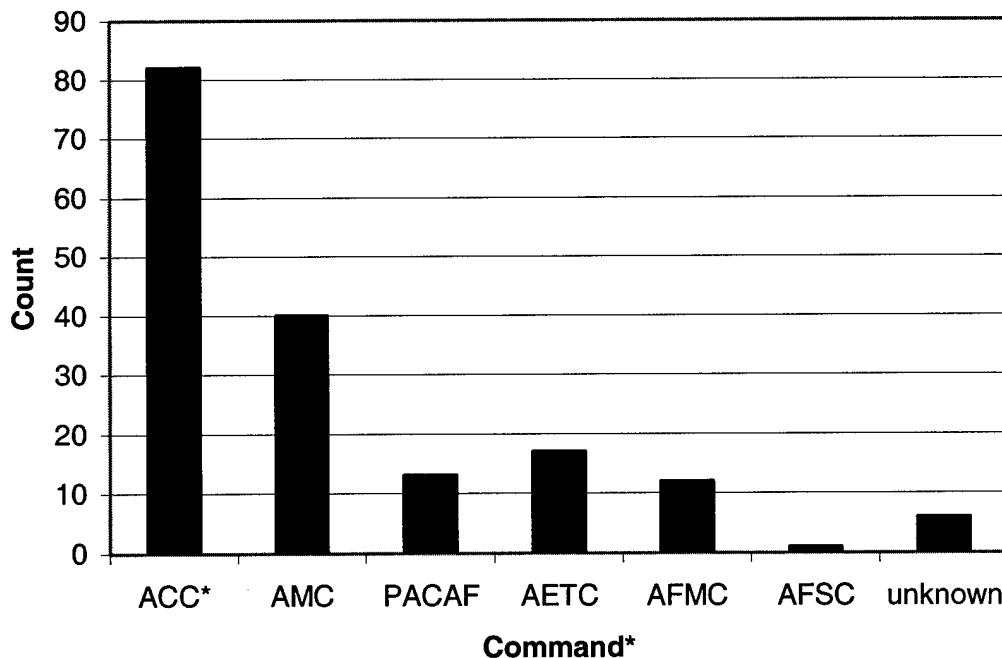

*--Air Force Command: ACC=Air Combat Command, AMC=Air Mobility Command, PACAF=Pacific Air Force Command, AETC=Air Education and Training Command, AFMC=Air Force Materiel Command, AFSC=Air Force Space Command

Figure 13. Breakdown by Air Force Command, AEF Sub-Group

Confirmatory Structural Equation Modeling

The Model. Once the data was deemed acceptable according to the descriptive analysis above, the next portion of the analysis involved comparing the actual measured data with that expected from a theorized model of construct relationships. The appropriate method for such an investigation is a confirmatory structural equation model (SEM) analysis. An important assumption for equation modeling is that all measures behave normally. Tables in Appendix B summarize the skewness and kurtosis statistics for all measures. Each of the measures proves normal along both statistics with values at or below 1. The fundamental input for the equation modeling technique is the covariance matrix. All covariance matrices between measures and across groups are also located in Appendix B, Descriptive statistics. The theorized model built in Chapters I and II, the “hypothesized model” in this analysis is the model with which the sample data was compared against. The hypothesized model consists of five measured variables and five underlying, latent constructs. Of the latent constructs, only predictability is considered exogenous, having no theoretical influence from another latent construct, with the balance of the constructs classified as endogenous, theoretically influenced by other latent constructs.

Goodness of Fit Indices. The evaluation statistics for structural equation modeling are generally referred to as Goodness of Fit Indices (GFIs). GFIs can be categorized under four measure classes: saturation, absolute fit, parsimonious fit, and relative fit. For saturation, this study relied on the statistic of degrees of freedom. For absolute fit the study employed two statistics, Chi Square (χ^2) and Standard Root Mean

Square Residual (Std. RMR). The statistic used for parsimonious fit was the Root Mean Square Error of Approximation (RMSEA). The final measure class, relative fit, was studied with the statistic of the Comparative Fit Indicator (CFI). Table 10. summarizes the models, the values of each statistic for models considered, and the acceptability criteria for each.

Table 10. Confirmatory Structural Equation Model Statistic Summary

Model Diagram	Degrees of Freedom	Chi Square (χ^2) [significance]	Std. RMR	RMSEA	CFI
1. Hypothesized Model *					
	4	10.06 [.039]	.045**	.065**	.99**
2. Revised Model *					
	3	.36 [.95]**	.005**	.000**	1.00**
Criteria for Acceptable Fit	N/A	[x] > .05	< .05	< .08	> .90

*--P = Predictability, W = Work-Family Conflict, J = Job Satisfaction,
 O = Organizational Commitment, R = Intent to Stay
 **--Indicates criteria met

The hypothesized model, while meeting the criteria for nearly all considered GFIs, failed to meet that for the χ^2 statistic ($p = .039$). Modification indices provided by the LISREL program indicated a strong relationship between predictability and job satisfaction. The addition of this path to the hypothesized model constitutes the revised

model. The revised model, in addition to improving the CFI indicator (from null = .99 to alternate = 1.00), improved model fit among all other considered indices. The values for the measures for the revised model included: χ^2 at .36 with a significance of .95 (criteria $p > .05$), Std. RMR at .005 (criteria $< .05$), RMSEA at .000 (criteria $< .08$), CFI at 1.00 (criteria $> .90$).

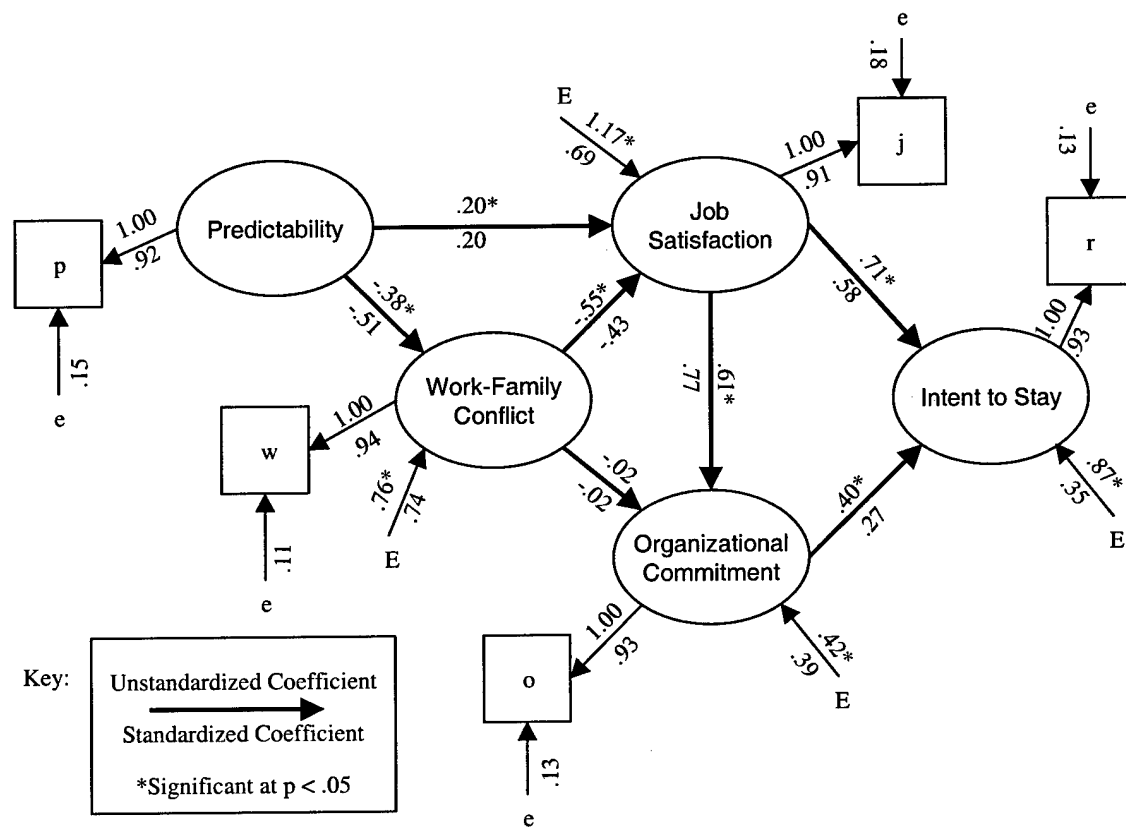

Figure 14. Path Analysis Model of the Impact of Predictability on Intent to Stay

Path Coefficients. LISREL provides estimates for paths between all latent constructs. These path coefficients are useful in comparing the relative influence of one construct on another. The coefficient represents the effect in the target construct's value (on a 1-7 scale) that can be expected by the increasing the influencing construct's value

by one (again, on a 1-7 scale). Influencing constructs are at the tail of the arrows in model diagrams while target constructs are found at the head of arrows. Standardized coefficients are adjusted for differences in scale; unstandardized coefficients are not adjusted for such differences. Additionally, the software provides paths coefficients between the latent constructs and the measured variables. Measurement errors are also estimated for measured variables, graphically represented as “e”s. Measurement errors are calculated by subtracting the Chronbach’s alpha value for each measure from one, and are treated as inputs to the LISREL program. The amount of variance unaccounted for in the latent construct, essentially 1 minus the r^2 value, is represented by an “E”. LISREL estimates the unaccounted variance for each latent construct and presents these values as output. Figure 14. illustrates the path coefficients and error contributions for the revised model.

Between-Groups Analysis

Between Groups MANOVA. Chapters I and II theorize a difference for path relationships between two separate, mutually exclusive sub-group pairs. A MANOVA for each of the study’s measures across the subgroups was warranted to identify any actual differences. The MANOVA subgroups included: (a) those who reported AEF assignment and those who reported no AEF assignment and (b) those who reported having dependents and those who reported not having dependents (including divorcees). Table 11. summarizes the results of the comparisons for both sets of groups. No significant differences were observed for any of the measures across the groups of dependent and no dependent individuals. Significant differences were found when comparing the measures across the sub-groupings of AEF and Non-AEF individuals.

Specifically, The AEF defined sub-groups differed in the measure of predictability ($F = 20.237$, sig. = .000), WFC ($F = 9.429$, sig. = .002), number of times spent away from home (TDYs and deployments combined, $F = 9.414$, sig. = .002). Because the alternate structural equation model partially links the explanation of variance in WFC to predictability, it is important to identify any significant differences between the groups along this path. Since the number of times away differs for the AEF defined groups and it was not considered in this study's model, it should be examined in a future study.

Table 11. MANOVA Summary of Between Group Measures

Independent Variable	Dependent Variable	Degrees Freedom	Mean Square	F	Sig.
AEF Status	P	1	40.745	20.237	.000
	WFC	1	10.592	9.429	.002
	JS	1	6.370	3.098	.079
	OC	1	1.469	1.192	.276
	IS	1	5.560	1.956	.163
	TA	1	183.884	9.414	.002
Dependent Status	P	1	1.121	.556	.456
	WFC	1	1.739	1.548	.214
	JS	1	3.645	1.773	.184
	OC	1	2.421	1.965	.162
	IS	1	.299	.105	.746
	TA	1	8.183	.419	.518

*--P=Predictability, WFC=Work-Family Conflict, JS=Job Satisfaction, OC=Organizational Commitment, IS=Intent to Stay, TA=Times Away

Predictability-WFC Regression Analysis. Because a MANOVA only indicates a significantly different relationship, further study is necessary to determine if a path differential between sub-groups might exist. A graphical representation of the regression of predictability against WFC for both EAF defined sub-groups as well as the dependent defined sub-groups will indicate a potential path difference as a difference in regression

line slopes between groups. Figures 15 and 16 represent the simple regressions for predictability versus WFC, for the EAF and dependent sub-groups, respectively.

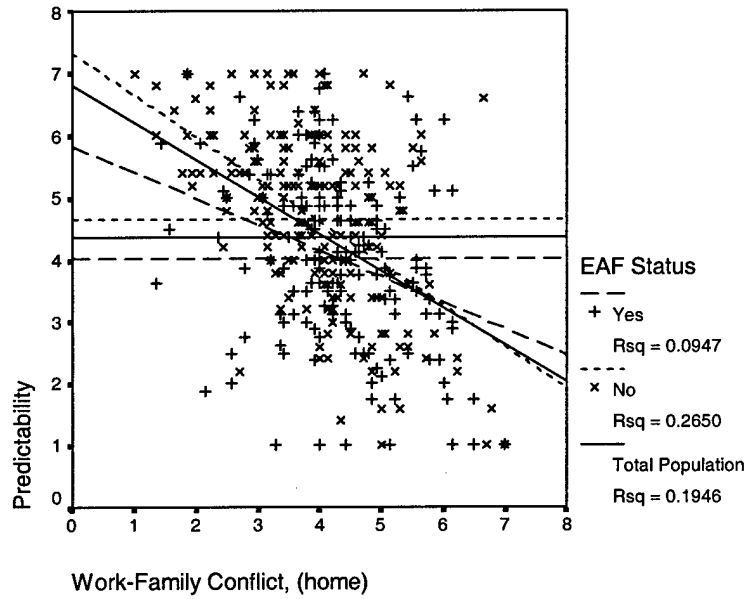

Figure 15. Predictability--WFC Regression Plot, EAF Status

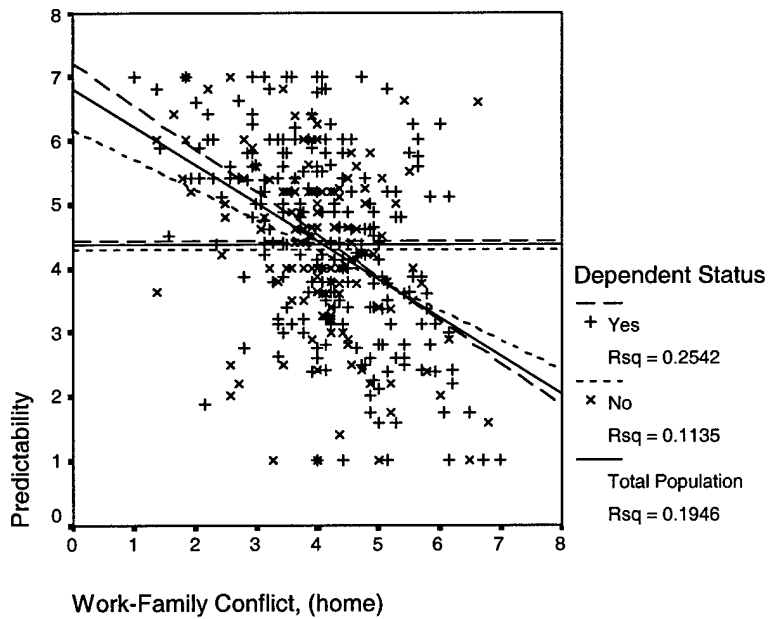

Figure 16. Predictability--WFC Regression Plot, Dependent Status

The decreased slope of Figure 15 for the Predictability--WFC measures of the EAF group indicates a weaker relationship between the constructs when compared to the slope of the Non-EAF group. When observing the same relationships in Figure 16, this time for the Dependent defined groups, the difference in relationship is similar, but smaller potentially indicating an similar difference between groups for the predictability and WFC relationship. The indicated differences in the construct relationships warrant a further testing via a between-groups equation model comparison, to confirm such relationships and to quantify the differences in terms of path coefficients.

Between-Groups Structural Equation Model Comparison. Because the measure of Predictability proved to be statistically different for mutually exclusive subgroups, it is important to examine the impact that such group differences have on the estimated path coefficients of the alternate structural equation model. The technique used to examine the effects of such subgroups involves a two step process. The first step analyzes the fit of the alternate model without alteration using separate covariance matrices for both subgroups. This model is commonly referred to as the unconstrained model. The second step involves fixing the path of interest to be equal between groups followed by another fit analysis using both covariance matrices. This model is commonly referred to as the constrained model. A significant difference in the χ^2 fit indicators between the constrained and unconstrained models indicates a significant difference in the path coefficient relationships. Uniquely, both models' χ^2 measures are assumed to follow a χ^2 distribution.

Predictability-WFC EAF Group Comparison. Table 12 summarizes the comparison of the Chi square statistic for both the constrained and unconstrained models

of the predictability-WFC path based on EAF assignment. The delta Chi square value of 2.73, with a delta degree of freedom of one, failed to display a significant p-value (.098 > .05), therefore, the null hypothesis, that the subgroups' predictability measures explain similar amounts of variance in their WFC measures in similar proportions is not rejected. Because a between groups difference is not accepted, the path coefficients and explained variance from the full model are accepted as valid across EAF assignment.

Table 12. AEF Status Sub-Group Comparison for the Predictability--WFC Path Constraint

	Unconstrained	Constrained	Delta	P-value*
Chi Square	19	21.73	2.73	0.098
Degrees Freedom	6	7	1	

*Significant at P < .05, AEF n=171, Non-AEF n=191

Predictability-WFC Dependent Group Comparison. Table 13. summarizes the comparison of the Chi square statistic for both the constrained and unconstrained models of the predictability-WFC path based on the presence of dependents. The delta Chi square value of 6.4, with a delta degree of freedom of one, displayed a significant p-value (.011 < .05), therefore, the alternate hypothesis, that the subgroups' predictability measures explain dissimilar amounts of variance in their WFC measures is also accepted. Because a between groups difference is accepted, path coefficients must be reexamined. Figure 17. displays the path coefficients for both the dependent and no dependent subgroups, utilizing the measure of WFC while individuals are at home.

Table 13. Dependent Status Sub-Group Comparison for the Predictability--WFC Path Constraint

	Unconstrained	Constrained	Delta	P-value
Chi Square	2.51	8.91	6.4	0.011*
Degrees Freedom	6	7	1	

*Significant at P < .05, Dependents n=224, No-dependents=138

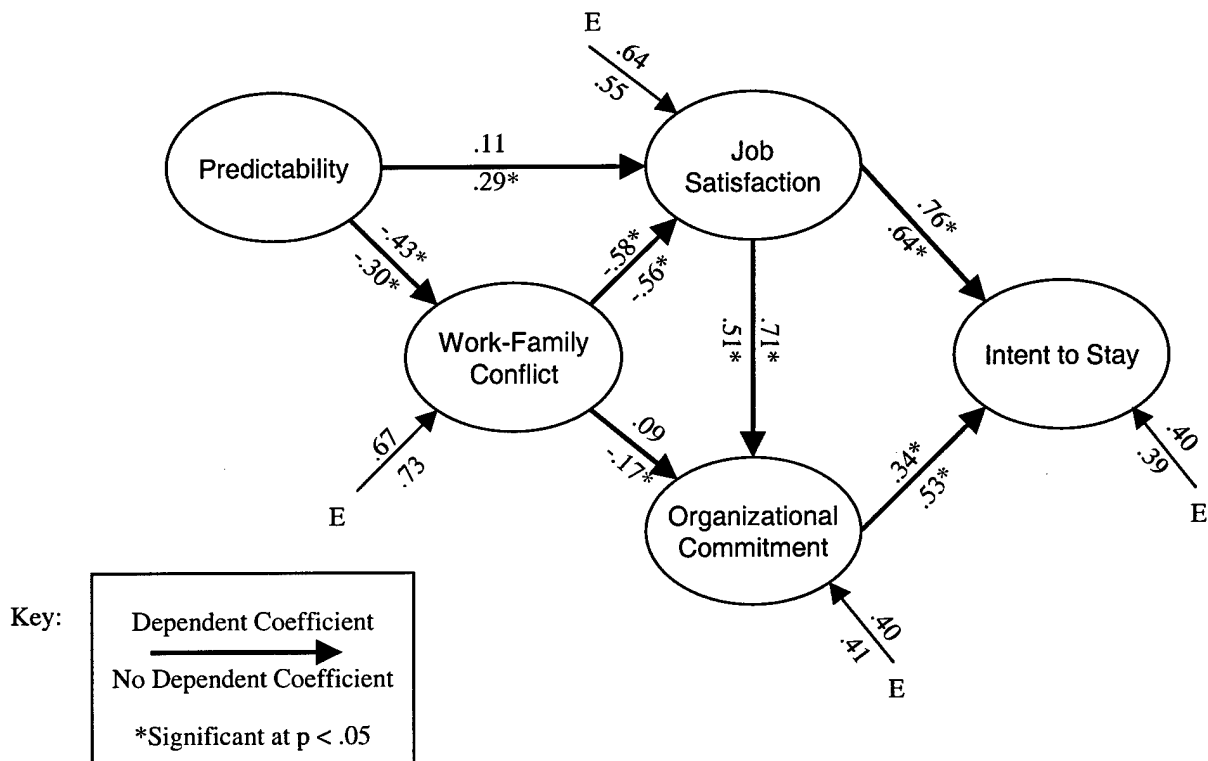

Figure 17. Path Analysis Model, Dependent Status Sub-Groups

Summary

An overall model relating predictability to job satisfaction, WFC, organizational commitment, and intent to stay was developed (Table 10). A factor analysis showing

distinctly loading factors, combined with the acceptable reliability statistics of Chapter III, added to the validity of the study measures. A revised model of the theoretical constructs, as suggested by the LISREL modification indices, added a relationship between predictability and job satisfaction (see also Table 10). The revised model improved model fit across all GFIs over and above that of the hypothesized model by adding a path between predictability and job satisfaction. A MANOVA analysis identified constructs where differences were expected (predictability—WFC) between the demographically exclusive groups based on AEF assignment, but found none for the groups defined by dependent status. Because the revised model links the differing constructs of predictability and WFC, and a regression analysis suggests a different relationship based on AEF assignment and dependent status, a further analysis of the path between the two constructs was warranted across each pair of sub-groups. While the model suggested different path coefficients and explained variances for the dependent sub-groups based on better model fit, no differences were found for the AEF status groups. A qualitative review of these results is included in Chapter 5: Discussion.

V. Discussion

Research Question

The study was fundamentally based on the question of whether or not predictability is an influencing factor on Air Force members' intentions to stay from a psychologically measured frame of reference. The motivation for this question lies in the attempt by the Air Force to increase deployment predictability for its personnel, an area of increasing concern in the late 1990s and early 2000s as Chapters I and II suggest. Ideally, the study's findings could be compared to the objective predictability data that the US Air Force currently collects such as the number of days of notification prior to an actual deployment or days spent away from home-station. In the place of such objective data, the study relies on a survey in which respondents report the number of times they spent away from home, to judge the objective measure influence on the relationships. Additionally, a psychological perspective should add another dimension to the US Air Force's objective look, strengthening any claims made to the population of deployable airmen and to concerned outside organizations as well. Several hypotheses, based on a review of the literature, emerged as important in answering the question: Is predictability an influencing factor on the intent of an individual, active duty airman to stay in the Air Force?

Implications for the Air Force

Differences from the Initial Model. Hypothesis 1 theorized that predictability, through several intermediary constructs, influenced an individual's intent to stay by acting through WFC. While the originally hypothesized model failed to meet the criteria

for a good representation of the constructs, the addition of a direct path between predictability and job satisfaction increased the model fit to an acceptable level. While a direct relationship between predictability and WFC was not initially seen as important, a careful review of the logic justifies such a relationship. Too much predictability in a job might lead to a decrease in job satisfaction. Too little predictability can lead to chaos and confusion. The analogy here is the traveling salesman who has no idea of which territory he will cover next. In between these two extremes would be a somewhat, but not perfectly predictable job. If one assumes normality, this middle ground would be where most jobs would fall. If someone's job becomes more predictable, an argument might be made that the decrease in chaos that results might increase one's satisfaction with their work. Thus, while predictability's impact on job satisfaction is logically warranted, it makes sense that it would be less of an impact than another construct, say WFC unless predictability were at an extreme.

Job Satisfaction, Organizational Commitment, and Intent to Stay. The relationships between job satisfaction, organizational commitment, and intent to stay compared well with those found in the literature. The impact of job satisfaction and organizational commitment on intent to stay compare well to that found by Tett and Meyer's meta-analytic study (1993). The strong path relationship between job satisfaction and organizational commitment completes this tri-construct relationship, and again compares well to Tett and Meyer's study (1993) and also to Rousseau's (1998) notion of correlated outputs from the social contract. This suggests that the primary influences on intent to stay for the general population of Air Force members are similar to those for the population outside the military. Other influences not accounted for by the

model certainly exist. Some of these might include the job market external to the Air Force, the current pay scale and benefit package, or the relative life safety felt by an individual. Each of these may be found as influences outside of the Air Force as well. Thus, conclusions concerning the direct influences on intent to stay for airman might not be much different than those found outside the military. Having noted the parallel intent to stay influences between military and non-military populations, the next logical step is to examine the driving factors behind those influences.

Predictability and Work Family Conflict. In terms of the impact of WFC on organizational commitment, no statistically significant relationship was found in this study. While there certainly are other factors influencing organizational commitment such as the job satisfaction influence noted above, for this study, WFC seems to be a non-factor. This may indicate that individuals within the Air Force recognize feelings of commitment without much regard to the level of WFC. Decreasing WFC will probably not give the Air Force more committed airmen. Looking at job satisfaction, the construct has two theorized influences. Because the alternate model added a path relationship to job satisfaction, both predictability and WFC play a role in explaining the construct's variance. The statistical results indicate that the more important influencing factor on job satisfaction, for the entire sample, is WFC. Thus, making airmen's deployment schedules more predictable will have a smaller effect on their job satisfaction than decreasing WFC, so finding ways to decrease WFC would provide the Air Force with a higher payback. The final relationship, that between predictability and WFC, showed that the former construct explained a significant portion of the variance in the latter. Because a predictable deployment schedule would help individuals decrease the conflict with their

home schedules, it is likely that individuals with dependents will gain more benefit from predictability decreasing WFC, as this study suggests. All things considered, this study provides evidence that predictability is an influencing factor on intent to stay, but that relationship is limited by and influenced through intermediary constructs, some of which this study measured, and others of which can only be theorized.

Implications for The Presence of Dependents

With the logic that WFC requires some form of a family relationship, it makes sense that those with dependents would experience a greater decrease in WFC as schedule predictability increases. Hypothesis 2 theorized that a respondent's report of the presence of dependents would indicate such a difference in the path coefficient between predictability and WFC. A between groups analysis indicated that such differences existed. A closer examination of the two emergent models indicates that the general theoretical relationships, acceptable for the entire sample population, fits better for those with dependents than for those without. Each of the r^2 values (1-"E") for the dependent group's paths were larger than the corresponding statistic for the non-dependent subgroup. While this difference indicates that the path relationships "fit" the dependent group better, enough variance is explained in the non-dependent group to continue to support a good fit, just to a lesser extent than its paired group. The practical significance of this improved fit might indicate that the EAF program, whether planned or unplanned, is more of a family oriented program and has less meaning for single airmen.

Implications for the EAF

If differences were found between the groups with dependents and no dependents, similar differences in the influence of the predictability construct might exist with regard

to assignment to an AEF. Those individuals who do not live under the threat of deployment as part of an AEF might rely less on predictability to reduce WFC than for those where the threat exists, the AEF assigned group. Surprisingly, a similar technique of between groups analysis showed no significant difference between AEF groups. Thus, breaking the group down by AEF assignment does not improve model fit. The full, revised model fits just as well for either group. This indicates that predictability, WFC, job satisfaction, and organizational commitment's impact on intent to stay is similar regardless of AEF status. The implication here is that schedule predictability is important not only to airmen who deploy as part of an AEF, but to those who are away due to TDYs (often shorter in duration than deployments) or those who do not leave their home station at all. Issues that are important for EAF members with regards to these constructs seem to be important for those not assigned under the EAF and vice versa.

Generalizability

Officer versus Enlisted. Any significant difference in the demographic make-up of the sample and the population will decrease the generalizability of the conclusions to the targeted group of the research question. In terms of the demographic of rank, the sample ratio of 2:1 enlisted to officer is higher than the population ratio of 4:1. This indicates an over-sampling of officers, potentially due to a method effect. More officers have regular access to computers on the job, the primary collection media employed in this study. This same logic also offers an explanation of the relatively high proportion of senior enlisted personnel as indicated in Figure 10. The following summarizes two potential impacts of such a demographic skew: (a) attitudes of junior enlisted personnel

are absent from the analysis and that those attitudes may alter the results and (b) that junior enlisted personnel spend more time in basic training and other initial skills development positions and typically do not deploy in the same number as more senior enlisted personnel. While the junior enlisted opinions might prove useful to understanding what individuals think of the EAF program prior to assignment under it, they are less useful in understanding the impact of those currently in an AEF. Thus, the impact of the senior enlisted skew should have minimal impact on the results.

Married versus Single. This section focuses on marital status as a substitute for dependent status as the Air Force data on marriage is more accurate than that for dependents. In terms of marital status, the sample ratio of 3:1 married to single as compared to the general Air Force population ratio of 3:2, indicates an over sampling of married individuals. Potential causes of this over-sampling lie in the aforementioned over-sampling of officers and senior enlisted personnel, who tend to be married in higher proportions than junior enlisted personnel. The study should reduce the potential impact of such a skew as the married and single sub-groupings as a general rule classify the same individuals together that the analyzed, dependent and no dependent sub-groups do.

AEF versus Non-AEF. The final demographic of concern to generalizability is that of AEF status. The ratio of AEF assigned personnel to Non-AEF assigned personnel is approximately 3:2 while the study's sample includes a ratio of approximately 1:1. While this is not a factor in the subgroup comparisons (the sub-groups were defined based on this demographic), the effect on the overall model estimation may have over-sampled non-AEF assigned personnel. This may be an indication for why the theoretical model fit the Non-AEF group better. One potential reason for apparent over-sampling is

that AEF assigned personnel are simply away from home for longer periods of time, and thus have a reduced access to the survey medium, work-email.

Research Impact

Impact for the Unit Commander. Probably the most important section of the thesis is the impact that the research has for the Air Force and the behavioral science community as well. Because the unit commander is ultimately responsible for assigning individuals to the requirements of each AEF, the leader must understand the impact that those assignment decisions have on the airmen. With retention of trained individuals a desired goal, predictability, most likely, is an important factor in the decision to stay with the Air Force. For AEF individuals the primary path of impact is directly through job satisfaction. If AEF airman have predictable lives, they are more likely to have satisfying jobs. While predictability proved to be a major factor in determining WFC for AEF airmen, WFC itself also proved a significant factor in job satisfaction, and thus intent to stay. What this means is that giving predictable schedules to deployable airmen is not enough. The unit commander must recognize and minimize the conflict that a deployable job causes with family lives.

Impact for the Air Force. For the Air Force in general, predictability is most likely an important factor for all airmen, regardless of assignment under the AEF. While the Air Force has focused on increasing the schedule predictability for AEF airmen, the study indicates that significant improvement on retention might be made by increasing the predictability of the non-AEF group's schedules due to the similarities in model fit between the groups.

Impact for the Behavioral Science Community. For the behavioral science community, this study adds a better understanding of the antecedents to the generally accepted job satisfaction/organizational commitment/intent to stay relationship. Schedule predictability and WFC seem to explain important amounts of the variance of job satisfaction.

Limitations

Sampling. Sampling limitations hindered the ability of the study to ensure that all demographics were chosen in adequate numbers. The limitations of the Air Force personnel database restricted the search categories to those that the Air Force tracks well (marital status in place of dependent status). The database also limited the number of search categories used simultaneously, hindering the stratified sampling technique.

Data Collection. While the web survey aided in the accurate retrieval of data, several problems existed. Data could only be collected from individuals who had access to a computer, e-mail, and the world wide web. While this may have been the case for officers and senior enlisted personnel, the lack of access may have explained the under-representation of junior airmen in the sample. Junior airmen are more likely to be doing work that keeps them away from a desk-bound job, work such as maintaining aircraft, installing communication lines, or repairing roads.

Statistical Analysis. The technique used in this study, SEM, while highly sophisticated, still has drawbacks when one attempts to draw conclusions about causality. For instance, did the attitudes that the sample respondents exhibited exist prior to the implementation of the EAF program?

Suggested Areas for Further Research

Longitudinal Data. This study provides a cross-sectional study of the feelings of active duty Air Force personnel in at a certain point in time: the month of December, 2000. In order to examine the impact that the AEF program itself is having on the Predictability to Intent to Stay relationship, a future study should be conducted, using the same or similar measures and techniques. Such a new study could then be compared to this data and analysis. As the AEF program matures, there may be differences in the constructs that will indicate an impact on the individual and his behavior.

Links to Objective Data. This study linked individual self-report measures of times and days spent away from home over a year prior to the administration of the survey. Respondents may have forgotten, estimated, or mistakenly reported such data. A method that clearly links a specific individual with objective deployment data maintained by the Air Force will not only provide a more accurate representation of objective deployment data, but will allow the tracking of actual retention, rather than intent to stay.

Improved Measures. While all measures proved reliable, better adaptations of the borrowed measures would improve the quality of the data. For instance, the item asking if an individual will be with the Air Force in five years failed to account for retirement or other non-voluntary means of leaving the organization. Additionally, the survey utilized the same items to judge WFC both while at home and while away from home. Important time management decisions, such as whether to stay at work late or to return home to spend time with a family, are entirely relevant while an individual is not deployed, but are not factors when an airman is deployed. The time trade-off between work and family is removed from that individual's control.

Final Thoughts

In the end, the study lent some credence to the notion that predictability, via WFC, job satisfaction, and organizational commitment, impacted the intent to stay of the selected case study: Air Force EAF members. While much of the initial goal of explaining the EAF program's role in the relationships cannot be determined without further study, the research is a step forward to understanding a real-world problem via behavioral measures. The hope exists that this research, combined with further studies, will enable the US Air Force to have a more comprehensive understanding of the motivation of its airmen and the impact that its policies have upon them.

Appendix A: Survey Package

**DEPARTMENT OF THE AIR FORCE
AIR UNIVERSITY (AETC)**

**Survey
Page 1**

Expeditionary Air Force Attitude Survey

INSTRUCTIONS

The objective of this survey is to better enable Air Force leaders to understand and improve the quality of life for airmen. Completion of this survey is entirely voluntary.

Please answer all items by filling in the appropriate spaces directly on the survey itself or by writing a response in the space provided. If, for any item, you do not find a response that fits your situation exactly, use the one that is the closest to the way you feel.

Your reply will be treated in strict confidence and will be available only to the researcher and the research advisor. In addition, when the results of this study are published, readers will not be able to identify specific individuals. Results of this survey will be available upon request to the researcher.

Thank you for your cooperation in participating in this study. If you have any questions, please contact the researcher, Captain Patrick J. Obruba at:

Capt Patrick J. Obruba, USAF
AFIT/ENV BLDG 640
2950 P Street
Wright-Patterson AFB OH 45433-7765
Phone: (937) 255-2998
Fax: (937) 656-4699
e-mail: patrick.obruba@afit.af.mil

PART I: DEPLOYMENT/TDY HISTORY

For the purposes of this survey, a DEPLOYMENT is defined as an official duty away from home, where the Airman is temporarily assigned to another unit. A TDY is defined as an official duty away from home where there is no change of assignment.

1. Are you currently assigned to a unit deployable under the Expeditionary Air Force (EAF)?
Yes No

2. Were you deployed for more than 30 consecutive days over the past year?
Yes No
How many total times were you deployed over the last year?
How many total days were you deployed over the last year?

3. Were you on a TDY of any length over the past year? (Not including deployments as defined above)
Yes No
How many total times were you TDY over the last year?
How many total days were you TDY over the last year?

(This page NOT part of survey, for reference only)

EAF Assigned? (Page 1, Question 1)	Predictability Form Version	Deploy > 30 Days? (Page 1, Question 2)	TDY > 30 Days? (Page 1, Question 3)	Work-Family Conflict Form Version
---------------------------------------	-----------------------------	---	--	-----------------------------------

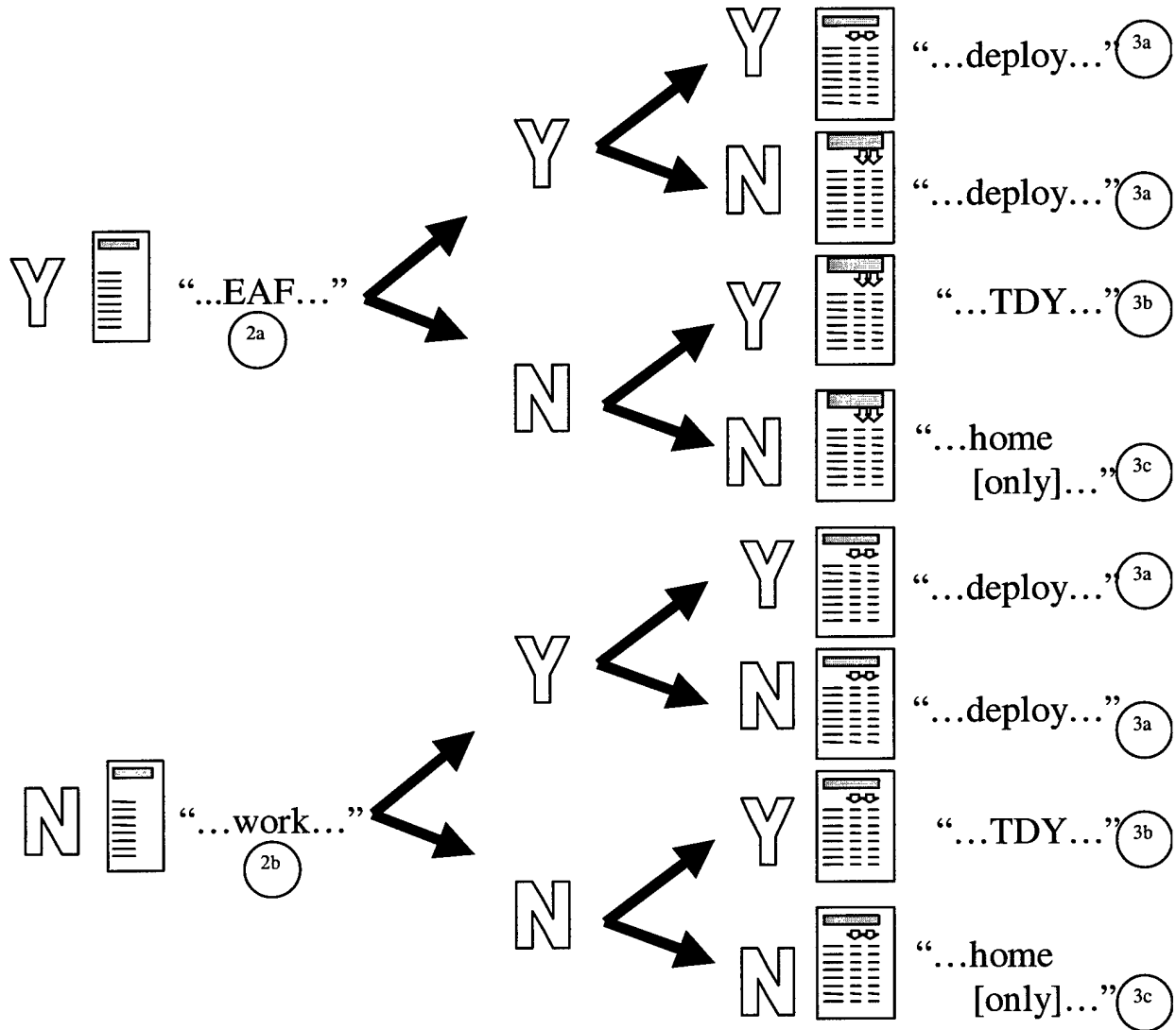

(Xy) = Survey Page, Version

Respondent Survey Page Filter

4. For these statements, please fill in the circle for the number that indicates the extent to which you agree the statement is true. Use the scale below for your responses.

1	2	3	4	5	6	7
Strongly disagree	Moderately disagree	Slightly disagree	Neither disagree nor agree	Slightly agree	Moderately agree	Strongly agree

- a. I feel certain about how my deployment schedule will turn out over the next 15 months.
- b. Being under the AEF schedule has made my life easier.
- c. I know my AEF deployment vulnerability times.
- d. Now that I am assigned to an AEF deployable unit, I can plan my life much better.
- e. Under the AEF program, my life is more predictable.
- f. There is uncertainty in my AEF schedule.
- g. The AEF provides clear, planned goals for my deployment schedule
- h. Explanation is clear as to my AEF schedule.

4. For these statements, please fill in the circle for the number that indicates the extent to which you agree the statement is true. Use the scale below for your responses.

1	2	3	4	5	6	7
Strongly disagree	Moderately disagree	Slightly disagree	Neither disagree nor agree	Slightly agree	Moderately agree	Strongly agree

- a. I feel certain about how my Air Force schedule will turn out over the next 15 months.
- b. My Air Force schedule has made my life easier.
- c. With my Air Force schedule, I can plan my life much better.
- d. There is uncertainty in my Air Force schedule.
- e. Explanation is clear as to my Air Force schedule.

5. For these statements, please fill in the circle for the number that indicates the extent to which you agree the statement is true. Use the scale below for your responses.

1	2	3	4	5	6	7
Strongly disagree	Moderately disagree	Slightly disagree	Neither disagree	Slightly agree	Moderately agree	Strongly agree
			nor agree			

Answers in column 1 reflect feelings while NOT deployed.

Answers in column 2 reflect feelings while deployed.

- a. My work keeps me from my family more than I would like.
- b. I often feel the strain of attempting to balance my responsibilities with work and family.
- c. The things I do that make me effective at work also help me to be a better family member.
- d. My work takes up time that I feel I should spend with my family.
- e. Because my work is so demanding, I am often irritable with my family.
- f. What works well for me with my family seems to be effective at work as well, and vice versa.
- g. The time I must devote to my job does not keep me from participating equally in family responsibilities and activities.
- h. The demands of my job make it difficult for me to maintain the kind of relationship with my family that I would like.
- i. I am not able to act the same way with family as at work.
- j. I generally seem to have enough time to fulfill my potential both in my career and as a family member.
- k. The tension of balancing my responsibilities with my family and work often causes me to feel emotionally drained.
- l. I act differently in responding to interpersonal problems at work than I do with my family.
- m. The problem solving approaches I use in my job are effective in resolving problems with my family.
- n. Behavior that is effective and necessary for me at work would be counterproductive with my family.

5. For these statements, please fill in the circle for the number that indicates the extent to which you agree the statement is true. Use the scale below for your responses.

1	2	3	4	5	6	7
Strongly	Moderately	Slightly	Neither	Slightly	Moderately	Strongly
disagree	disagree	disagree	disagree	agree	agree	agree
			nor agree			

Answers in column 1 reflect feelings while NOT TDY.

Answers in column 2 reflect feelings while TDY.

- a. My work keeps me from my family more than I would like.
- b. I often feel the strain of attempting to balance my responsibilities with work and family.
- c. The things I do that make me effective at work also help me to be a better family member.
- d. My work takes up time that I feel I should spend with my family.
- e. Because my work is so demanding, I am often irritable with my family.
- f. What works well for me with my family seems to be effective at work as well, and vice versa.
- g. The time I must devote to my job does not keep me from participating equally in family responsibilities and activities.
- h. The demands of my job make it difficult for me to maintain the kind of relationship with my family that I would like.
- i. I am not able to act the same way with family as at work.
- j. I generally seem to have enough time to fulfill my potential both in my career and as a family member.
- k. The tension of balancing my responsibilities with my family and work often causes me to feel emotionally drained.
- l. I act differently in responding to interpersonal problems at work than I do with my family.
- m. The problem solving approaches I use in my job are effective in resolving problems with my family.
- n. Behavior that is effective and necessary for me at work would be counterproductive with my family.

5. For these statements, please fill in the circle for the number that indicates the extent to which you agree the statement is true. Use the scale below for your responses.

1	2	3	4	5	6	7
Strongly	Moderately	Slightly	Neither	Slightly	Moderately	Strongly
disagree	disagree	disagree	disagree	agree	agree	agree
			nor agree			

- a. My work keeps me from my family more than I would like.
- b. I often feel the strain of attempting to balance my responsibilities with work and family.
- c. The things I do that make me effective at work also help me to be a better family member.
- d. My work takes up time that I feel I should spend with my family.
- e. Because my work is so demanding, I am often irritable with my family.
- f. What works well for me with my family seems to be effective at work as well, and vice versa.
- g. The time I must devote to my job does not keep me from participating equally in family responsibilities and activities.
- h. The demands of my job make it difficult for me to maintain the kind of relationship with my family that I would like.
- i. I am not able to act the same way with family as at work.
- j. I generally seem to have enough time to fulfill my potential both in my career and as a family member.
- k. The tension of balancing my responsibilities with my family and work often causes me to feel emotionally drained.
- l. I act differently in responding to interpersonal problems at work than I do with my family.
- m. The problem solving approaches I use in my job are effective in resolving problems with my family.
- n. Behavior that is effective and necessary for me at work would be counterproductive with my family.

6. For these statements, please fill in the circle for the number that indicates the extent to which you agree the statement is true. Use the scale below for your responses.

1	2	3	4	5	6	7
Strongly disagree	Moderately disagree	Slightly disagree	Neither disagree nor agree	Slightly agree	Moderately agree	Strongly agree

- a. All in all, I am satisfied with my job.
- b. I am actively looking for a job outside of the Air Force.
- c. I could be very happy to spend the rest of my career with the Air Force.
- d. I enjoy discussing the Air Force with people outside it.
- e. I do not feel like part of the Air Force family.
- f. I do not feel emotionally attached to the Air Force.
- g. In general, I don't like my job.
- h. I am seriously thinking about quitting my job.
- i. I really feel as if the Air Force's problems are my own.
- j. I think that I could become as easily attached to some other organization as I am to the Air Force.
- k. I often think about quitting my job with the Air Force.
- l. I do not feel a strong sense of belonging to the Air Force.
- m. I will be working in the Air Force five years from now.
- n. In general, I like working in the Air Force.
- o. The Air Force has a great deal of personal meaning for me.
- p. As soon as I can find a better job, I'll leave the Air Force.

7. What is your gender?
8. What is your age in years?
9. What is your duty Air Force Specialty Code (AFSC), i.e., the authorized manning position to which you are currently assigned?
10. Indicate your rank:
11. What is the name of the base you are currently stationed at?
12. To what command are you currently assigned?
13. Are you currently married?
14. List the ages of any family members, other than a spouse, whom you would consider dependents:

This completes the survey. Thank you for your participation. If you have any additional comments please type them below.

Appendix B: Descriptive Statistics

Table B-1. Predictability Scale Statistics, Non-EAF Sample

	M**	SD	Sk	Ku	V	α	e
Scale*	4.65	1.45	-.43	-.46	2.09	.84	.33
a. I feel certain about how my Air Force schedule will turn out over the next 15 months.	4.79	2.01	-.64	-.95			
b. My Air Force schedule has made my life easier.	4.57	1.82	-.62	-.80			
c. With my Air Force schedule, I can plan my life much better.	4.79	1.79	.06	-.57			
d. There is uncertainty in my Air Force schedule. (rev)	3.95	1.99	-.95	-1.36			
e. Explanation is clear as to my Air Force schedule	5.13	1.58	-.43	.42			

*N of Cases = 191

**M = mean, SD = standard deviation, Sk = skewness, Ku = kurtosis, V = variance, α = Chronbach's alpha, e = estimated error [(1- α) x V]

Table B-2. Predictability Scale Statistics, EAF Sample

	M**	SD	Sk	Ku	V	α	e
Scale*	4.03	1.43	-.23	-.42	2.04	.91	.18
a. I feel certain about how my deployment schedule will turn out over the next 15 months.	4.23	2.01	-.32	-1.17			
b. Being under the AEF schedule has made my life easier.	3.68	1.69	-.02	-.64			
c. I know my AEF deployment vulnerability times.	4.82	1.94	-.63	-.74			
d. Now that I am assigned to an AEF deployable unit, I can plan my life much better.	3.87	1.78	-.12	-.91			
e. Under the AEF program, my life is more predictable.	3.79	1.81	-.02	-1.04			
f. There is uncertainty in my AEF schedule. (rev)	3.65	1.82	.30	-.87			
g. The AEF provides clear, planned goals for my deployment schedule	4.01	1.69	-.25	-.80			
h. Explanation is clear as to my AEF schedule.	4.16	1.76	-.23	-.84			

*N of Cases = 171

**M = mean, SD = standard deviation, Sk = skewness, Ku = kurtosis, V = variance, α = Chronbach's alpha, e = estimated error [(1- α) x V]

Table B-3. Work-Family Conflict Scale Statistics, At Home Measure

	M**	SD	Sk	Ku	V	α	e
Scale*	4.11	1.08	-.10	.17	1.17	.89	.13
a. My work keeps me from my family more than I would like.	4.16	1.92	-.17	-1.06			
b. I often feel the strain of attempting to balance my responsibilities with work and family.	4.48	1.83	-.37	-.81			
c. The things I do that make me effective at work also help me to be a better family member. (rev)	3.76	1.59	.18	-.39			
d. My work takes up time that I feel I should spend with my family.	4.21	1.74	-.18	-.81			
e. Because my work is so demanding, I am often irritable with my family.	3.67	1.76	.08	-.81			
f. What works well for me with my family seems to be effective at work as well, and vice versa. (rev)	3.87	1.33	.25	.67			
g. The time I must devote to my job does not keep me from participating equally in family responsibilities and activities. (rev)	4.23	1.66	-.11	-.75			
h. The demands of my job make it difficult for me to maintain the kind of relationship with my family that I would like.	4.05	1.77	-.17	-.90			
i. I am not able to act the same way with family as at work.	4.25	1.73	-.23	-.59			
j. I generally seem to have enough time to fulfill my potential both in my career and as a family member. (rev)	3.94	1.66	.07	-.79			
k. The tension of balancing my responsibilities with my family and work often causes me to feel emotionally drained.	4.28	1.76	-.24	-.59			
l. I act differently in responding to interpersonal problems at work than I do with my family.	4.67	1.61	-.34	-.36			
m. The problem solving approaches I use in my job are effective in resolving problems with my family. (rev)	3.96	1.49	.20	-.30			
n. Behavior that is effective and necessary for me at work would be counterproductive with my family.	4.17	1.55	-.11	-.28			

*N of Cases = 358

**M = mean, SD = standard deviation, Sk = skewness, Ku = kurtosis, V = variance, α = Chronbach's alpha, e = estimated error $[(1-\alpha) \times V]$

Table B-4. Job Satisfaction Scale Statistics

	M**	SD	Sk	Ku	V	α	e
Scale*	5.22	1.44	-1.00	.64	2.08	.82	.37
a. All in all, I am satisfied with my job.	4.94	1.78	-.91	-.22			
g. In general, I don't like my job. (rev)	5.30	1.78	-1.07	.22			
n. In general, I like working in the Air Force.	5.42	1.48	-1.00	1.74			

*N of Cases = 360

**M = mean, SD = standard deviation, Sk = skewness, Ku = kurtosis, V = variance, α = Chronbach's alpha, e = estimated error $[(1-\alpha) \times V]$

Table B-5. Organizational Commitment Scale Statistics

	M**	SD	Sk	Ku	V	α	e
Scale*	4.65	1.11	-.42	-.23	1.24	.87	.16
c. I could be very happy to spend the rest of my career with the Air Force.	4.77	1.92	-.65	-.67			
d. I enjoy discussing the Air Force with people outside it.	5.03	1.70	-.76	-.21			
e. I do not feel like part of the Air Force family. (rev)	4.76	1.79	-.32	-.99			
f. I do not feel emotionally attached to the Air Force. (rev)	4.69	1.91	-.43	-.98			
i. I really feel as if the Air Force's problems are my own.	3.93	1.69	-.11	-.82			
j. I think that I could become as easily attached to some other organization as I am to the Air Force.	3.74	1.69	.22	-.73			
l. I do not feel a strong sense of belonging to the Air Force. (rev)	4.75	1.86	-.39	-.98			
o. The Air Force has a great deal of personal meaning for me.	5.08	1.61	-.81	.08			

*N of Cases = 360

**M = mean, SD = standard deviation, Sk = skewness, Ku = kurtosis, V = variance, α = Chronbach's alpha, e = estimated error $[(1-\alpha) \times V]$

Table B-6. Intent to Stay Scale Statistics

	M**	SD	Sk	Ku	V	α	e
Scale*	4.42	1.70	-.31	-.79	2.88	.87	.38
b. I am actively looking for a job outside of the Air Force. (rev)	4.21	2.10	-.12	-1.23			
h. I am seriously thinking about quitting my job. (rev)	5.11	2.01	-.74	-.68			
k. I often think about quitting my job with the Air Force. (rev)	4.41	2.08	-.27	-1.22			
m. I will be working in the Air Force five years from now.	3.84	2.26	.03	-1.46			
p. As soon as I can find a better job, I'll leave the Air Force. (rev)	4.55	2.07	-.38	-1.07			

*N of Cases = 360

**M = mean, SD = standard deviation, Sk = skewness, Ku = kurtosis, V = variance, α = Chronbach's alpha, e = estimated error $[(1-\alpha) \times V]$

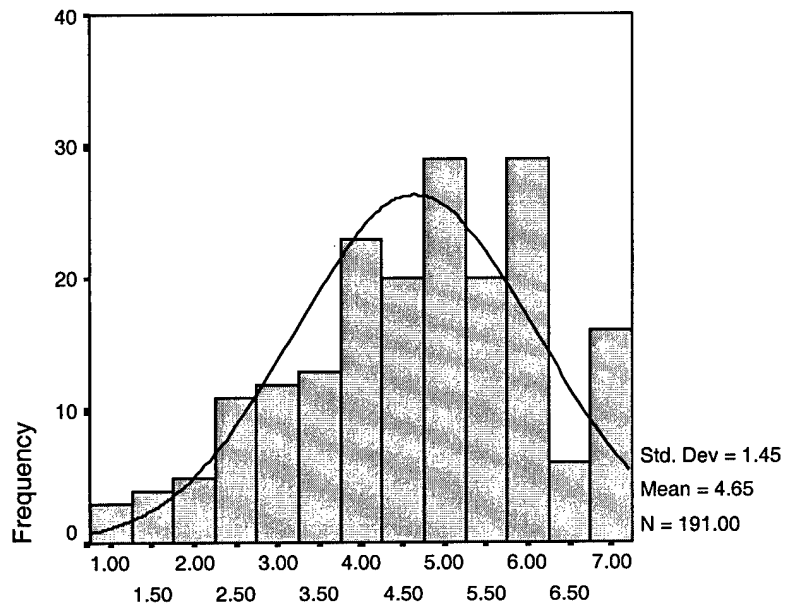

Non-EAF predictability

Figure B-1. Predictability Histogram, Non-EAF Sub-group

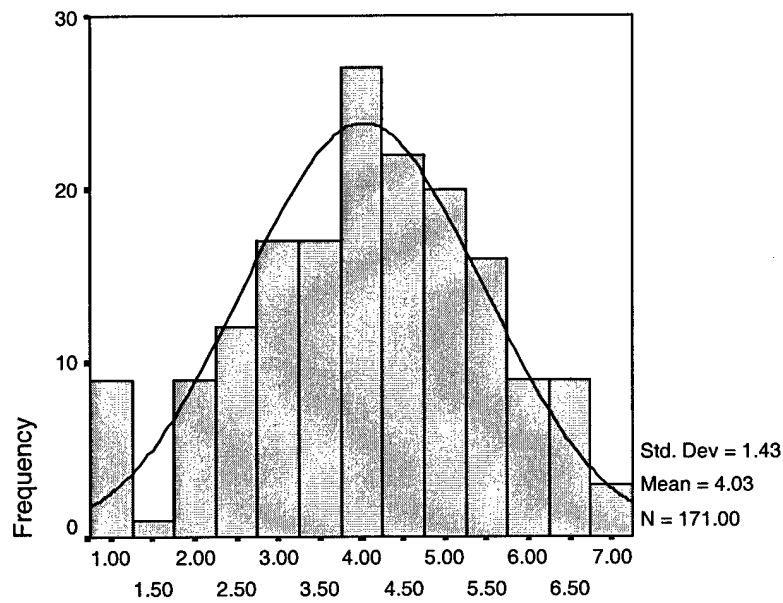

EAF predictability

Figure B-2. Predictability Histogram, EAF Sub-group

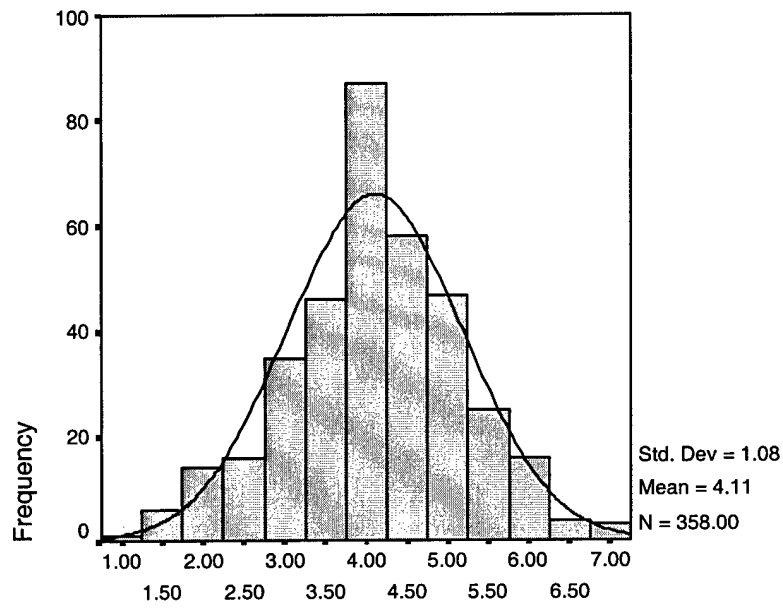

work-family conflict: home

Figure B-3. Work-family Conflict Histogram

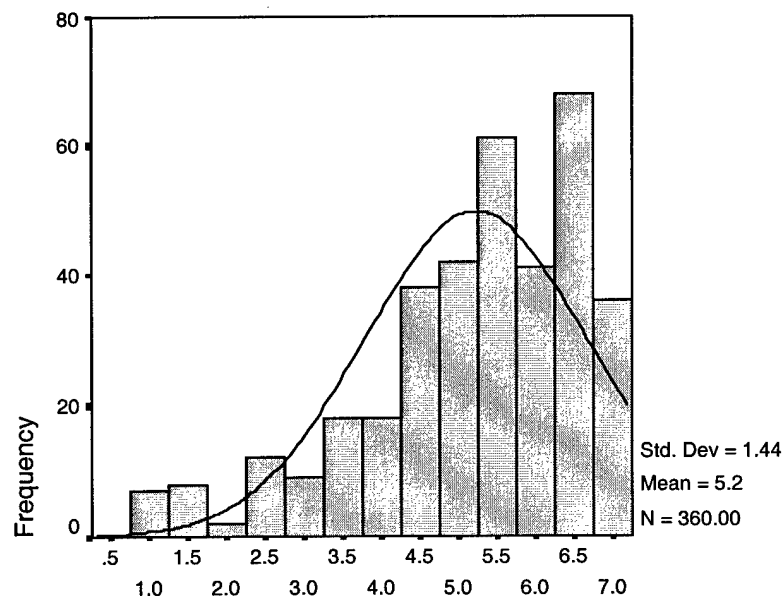

job satisfaction

Figure B-4. Job Satisfaction Histogram

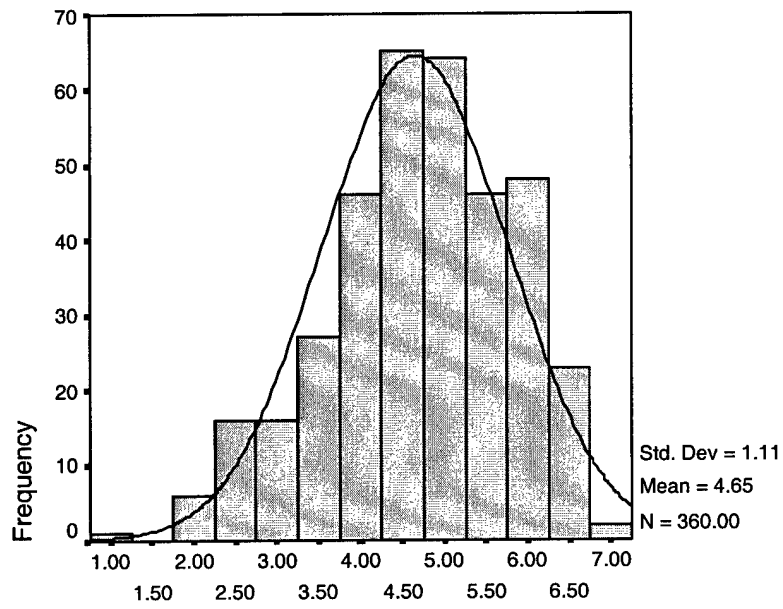

organizational commitment

Figure B-5. Organizational Commitment Histogram

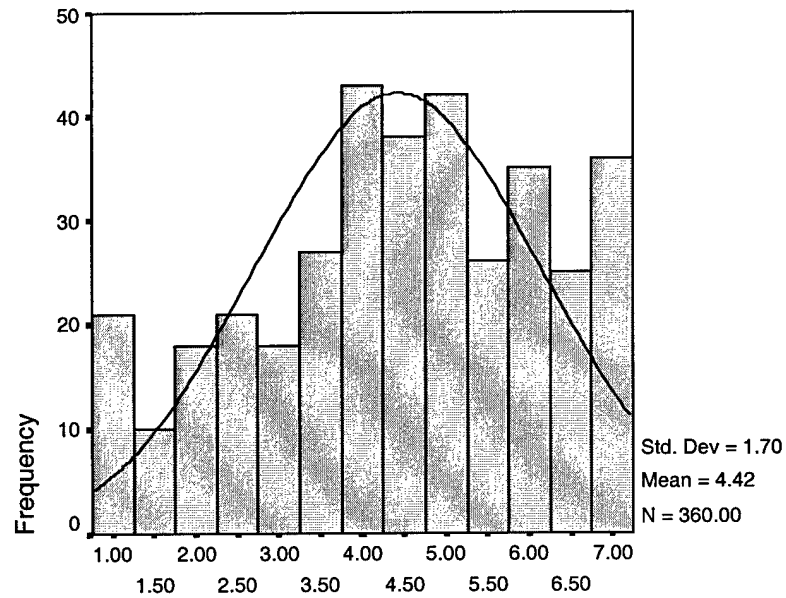

retention

Figure B-2. Retention Histogram

Table B-7. Covariance Matrix, Full Sample

Measure	1	2	3	4	5
1. Predictability	2.178*				
2. Work-Family Conflict	-.708	1.166			
3. Job Satisfaction	.754	-.700	2.076		
4. Organizational Commitment	.451	-.449	1.057	1.237	
5. Retention	.724	-.701	1.628	1.181	2.882

*Variances on diagonal, n = 362

Table B-8. Covariance Matrix, AEF Sub-group

Measure	1	2	3	4	5
1. Predictability	2.007*				
2. Work-Family Conflict	-.456	1.067			
3. Job Satisfaction	.546	-.782	2.245		
4. Organizational Commitment	.403	-.490	1.067	1.313	
5. Retention	.859	-.812	1.625	1.200	3.047

*Variances on diagonal, n = 171

Table B-9. Covariance Matrix, Non-AEF Sub-group

Measure	1	2	3	4	5
1. Predictability	2.091*				
2. Work-Family Conflict	-.810	1.201			
3. Job Satisfaction	.814	-.575	1.882		
4. Organizational Commitment	.436	-.387	1.025	1.160	
5. Retention	.482	-.552	1.584	1.139	2.689

*Variances on diagonal, n = 191

Table B-10. Covariance Matrix, Dependent Sub-group

Measure	1	2	3	4	5
1. Predictability	2.285*				
2. Work-Family Conflict	-.847	1.249			
3. Job Satisfaction	.717	-.741	1.817		
4. Organizational Commitment	.388	-.434	.962	1.240	
5. Retention	.759	-.733	1.416	1.098	2.804

*Variances on diagonal, n = 224

Table B-11. Covariance Matrix, No-Dependent Sub-group

Measure	1	2	3	4	5
1. Predictability	2.011*				
2. Work-Family Conflict	-.501	1.026			
3. Job Satisfaction	.778	-.657	2.487		
4. Organizational Commitment	.545	-.490	1.196	1.222	
5. Retention	.675	-.651	1.998	1.333	3.031

*Variances on diagonal, n = 138

Appendix C: Sample LISREL Program

*--bold line numbers added for clarity; not part of working program

```
001* OVERALL GROUP ANALYSIS, EAF PREDICTABILITY MODEL
002 DA NO=362 NI=5
003 LA
004 p w j o r
005 CM                ! p w j o r
006 2.178             ! p
007 -.708 1.166       ! w
008 .753 -.700 2.076  ! j
009 .451 -.449 1.057 1.237 ! o
010 .724 -.701 1.628 1.181 2.882 ! r
011 SE
012 w j o r p
013 MO NX=1 NY=4 NK=1 NE=4 LX=FU LY=FU TD=SY TE=SY BE=FU GA=FU
    PS=SY PH=SY
014 LK
015 PREDICT
016 LE
017 WFC JOBSAT ORGCOM RETEN
018 PA LX      !PREDICT
019 1          !p
020 PA LY      !WFC JOBSAT ORGCOM RETEN
021 1 0 0 0    !ws
022 0 1 0 0    !j
023 0 0 1 0    !o
024 0 0 0 1    !r
025 PA TD      !p
026 0          !p
027 MA TD      !p
028 .33        !p
028 PA TE      !w j o r
029 0          !w
030 0 0        !j
031 0 0 0      !o
032 0 0 0 0    !r
033 MA TE      !w j o r
034 .13        !w
035 0 .37      !j
036 0 0 .16    !o
037 0 0 0 .38  !r
```

038 PA PH !PREDICT
039 1 !PREDICT
040 PA GA !PREDICT
041 1 !WFC
042 1 !JOBSAT
043 0 !ORGCOM
044 0 !RETEN
045 PA BE !WFC JOBSAT ORGCOM RETEN
046 0 0 0 0 !WFC
047 1 0 0 0 !JOBSAT
048 1 1 0 0 !ORGCOM
049 0 1 1 0 !RETEN
050 PA PS !WFC JOBSAT ORGCOM RETEN
051 1 !WFC
052 0 1 !JOBSAT
053 0 0 1 !ORGCOM
054 0 0 0 1 !RETEN
055 FILX(1,1) LY(1,1) LY(2,2) LY(3,3) LY(4,4)
056 (1,1) LY(1,1) LY(2,2) LY(3,3) LY(4,4)
057 OU SC RS MI

notes:

- a. Lines 006-010 represent the inter-measure covariance matrix for the group under analysis.
- b. See Jaccard & Wan (1999) for a description of the programming techniques.

Appendix D: Relevant Survey Comments

*--indicates a comment that was truncated due to limited database field length

1. The questions regarding quitting your job are not realistic. How can you quit a four year contract? The question should have been: Do you plan to re-enlist?
2. We have too many deployments and not enough people in today's Air Force.
3. AEF's seem to work for the fly community, but for the support community it is not. Case in point, were on the hook for 5 months AEF 2 for a 7 level and a 5 level, the 7 level had a grade requirement for a E-6. 4 weeks before they were to leave someone...*
4. I love my job and would stay in for as long as I can however I will not go a second term simply because of the lack of money and the USAF not allowing my job to be done properly. If the Air Force keeps taking the good mechanics out of a mechanical career...*
5. While the concept of knowing when you are to deploy is good, the reality is that the needs of the Air Force come first. Many times personnel are pulled to deploy in the name of AEF only to really be doing a manning assist.
6. The assignment process is out there, and I have spent all my time on heavies (c-5) and try to stay only to be told there was no jobs, for there to be jobs available two weeks after I received my orders here is a perfect example of the reason good qualified...*
7. I think that all recruiters should have to come and work at least one week with these stupid, slow, lazy people that they are putting in the Air force these days. I've only been in 3 ½ years and the quality of people has drastically changed. My terminal...*
8. My negatives comes from years of short manning and "handle it or be destroyed" attitudes. Commanders and senior leadership seems to have no support for the small support organizations that just don't have the personnel or recourses to meet the requirement...*
9. I want to be deployed. The AEF prevents me from being deployed as much as I would like. I don't like it.
10. I like the AEF program because it is much more predictable and easier to plan for. My job is very tedious and dull at times. IT lacks much interest, and is considered a "bad job" by other units. This base is also hard to get away from, other than normal...*

11. I enjoy my service in the Air Force. Maybe it is because I do not have to go TDY that often. I've always been a Civil Engineer troop. I enjoy PCSing every few years to grow in my career. I plan on staying in the Air Force past the 20 year mark, as SMSgt I...*
12. I am currently not assigned to an AEF. However, my current position has me working in mobility. I understand how the AEF works and why it was implemented. I cannot strongly say that I agree with the program though. It seems that there is still a lot o...*
13. Why do individuals upon returning from SWA get compensatory time off, when individuals returning from a remote assignment do not?
14. I love my job but can no longer keep up the pace of doing more with less. Simply put, I am burned out and tired of doing the jobs of 3 people all the time. Sorry, but a 3.7% pay-raise doesn't make up for what we are being asked to do.
15. I deployed to Skopje, Macedonia in May 00 with one week notice. Fortunately I am not married or have any dependents, it could have been quite a hardship.
16. I don't feel that the EAF has help our Unit since we are 24 authorized personnel under manned. The Command continues to send us taskings but no to fill authorizations so we continue to work numerous hours with no light at the end of the tunnel. It's no...*
17. Although I know when I am slotted for deployment, my MAJCOM can't get it totally together and we continue to send folks out to AEF deployments with very little notice. This cause stress on the deploying member, member's family, the unit and co-workers.
18. The EAF effects me more due to the fact that I am married to an active duty member and he is sent TDY overseas several times a year even though I am not, which is a good thing since we have three boys.
19. An additional question might be how long have I been in the AF, which is just over 1 year. I'm also in a profession that is not typically selected to deploy, as far as I can tell. Examining the results by rank should yield interesting results, but also b...*
20. I've been in the AF for nearly 17 years, and overall I have enjoyed it very much. I've only been here at Nellis for 7 months, and I really don't enjoy my job here. I will probably get out after 20 years, because I'm tried of not having the equipment an...*
21. Although the AEF Rotations are not all inclusive to all types of deployments I may be sent on, they do allow for some degree of predictability. This will be of benefit to me as I can schedule my educational plans accordingly.

22. The reason I answered the way I did on the AEF questions because we have a say AEF time but we are also alternates for other AEF times. I had a 3 day notice deployment in 1999.
23. I love the Air Force, but I think that everyone should PCS or deploy more....esp. the younger troops. I have been at the same base for 4 years and would like to go overseas. I have been deployed one time. I just believe that most folks join to travel an
24. I feel we are underpaid for everything we do. As a Mid-grade NCO I have responsibilities that would mean a quite larger paycheck. The only reason why I haven't gotten out is that I am too close to retirement to give it all up now. I have seen lots of peopl...*
25. AEF needs more coordination, because the bases participating in AEF are short falling slots and then you are looking for people from other participating AEF bases who will shortfall eventually because you took someone that was already scheduled to AEF I...*
26. All in all for the five years I've been in, I've seen little improvement in the AF which is why we are hemorrhaging captains into a strong civilian economy. At the current rate of the Air Force's attempts to catch up the only way this will stop is a turn I...*
27. Overall, I am relatively satisfied with the US Air Force. I hope that it will become better as the years progress. Manning (lack of) is killing us, and today's recruits don't seem to be as "grown up" as those in the past. Letting anybody into the Air Force...*
28. Big problem with the EAF is that support units get more heavily tasked than operational units. Also, some units who could contribute to the overall force are ignored (i.e. tanker bases and training bases don't fully support EAF taskings in aircraft maint...*
29. I am on an enabler, so I answered 'yes' when asked if I'm on a deployable UTC, but many of the rest of the questions then did not seem relevant. I didn't understand many of the questions in section III and IV. I answered 'neither agree nor disagree' to...*
30. I feel that the AEF has been a great implementation into the Air Force. It has helped many families over it's course of time here at F.E. Warren maintain a sense of stability, along with feelings of home basing.
31. Manning at home station does not match the task commitment. AEF should not be manned at 100%. Our capability to rapidly deploy should be utilized more

effectively. Keep the bodies where the work is. The lack of manning on a daily basis is the core to...*

32. The AEF Concept when applied is not a Bad System, however when your assigned to a support AFSC under the AEF concept you'll deploy more often than under the palace tenure system. In a Support AFSC under the AEF concept myself as a UDM can almost guarantee
33. I will take this opportunity to identify, what I feel is a serious problem with morale. Ten years ago an NCO had and was permitted to use the authority granted them by virtue of their rank. Now, I find it more frequent that you cannot accomplish very muc...*
34. I am currently filling in as a Unit Deployment Manager. This is not part of my actual AFSC but I feel this job is more rewarding personally and keeps changing at such a steady pace that I do not have time to get bored. Of all the jobs I have had in my 19...*
35. Some of the questions you ask have an emotional aspect to them that cannot be expressed on a good/bad scale. For instance, some of the questions dealing with finding a job outside the Air Force infer dissatisfaction as the reason for seeking outside empl...*
36. AEF doesn't tell bomber units ANYTHING. We have a window, but no one know if we will deploy or not. Unlike fighter or AMC units, putting bombers on someone's doorstep is a political statement. We have more mobility slots than personnel assigned. The L...*
37. I do not believe that I am a good source of information for this particular survey, as I have only been a member of the Air Force for 4 months, have never been deployed, and am not even qualified yet to be deployed (despite the fact that I fill a UTC slot...*
38. Not allowing swap outs during deployments hurts morale tremendously. The extra cost of swapping out personnel during a 90 day rotation would make the AEF much better, if the squadron can support it.
39. The management of a base and unit makes and brake the moral, mission, and peoples will to give and support overall mission of type USAF. Poor commanders and supervisors are killing careers and as a whole increasing a breed of highly dissatisfied and resent...*
40. Exactly how are my responses, as well as my fellow airmen, going to be utilized to improve the quality of live in the AF? Will we realize the application of the

responses? I would love to know that the time taken to complete this form has not been in va...*

41. The AEF concept has some very beneficial aspects to it, however, there continues to be a flux that makes the realization of the concept problematic. Until someone puts their foot down on the theater requirements this will continue to be a problem. Fo...*
42. Budget cuts have made our job very difficult. We are always expected to do more with less. It is almost to the point of being impossible to get aircraft off the ground. I feel our situation is deteriorating at an exponential rate.
43. I am a member of the 752CSS. We are part of a HDLD Wing. We are not only deployed in support of multiple AEFs, we also continuously deployed in support of OSW, ONW and CDO. Due to us supporting AEFs and all other AWACS deployments the AEF really doesn'...*
44. I am currently medically cross-training from 1C53X1
45. I am due to retire from the Air Force in about 1 1/2 years. Generally speaking, the Air Force has been good to my family and me. I have seen a lot of change for the good, and maybe a little not so good, over the years. I have been through several year...*
46. I think the survey section in which you had to decide what you're feeling about your AF commitments while TDY vs. not being TDY are very confusing. Are you trying to prove that one's feelings toward the military are different when TDY vs. being at home? P...*
47. I'm in an Air Control Squadron and we're not really assigned to a specific AEF. The whole GTACS structure is being redesigned and the chaos associated with it is frustrating. I have no clear guidance on when I'm deploying or what rotational basis I'm on...*
48. Very difficult to answer most questions of this survey. Our wing is not assigned to an numbered AEF...the wing is assigned to an AEW. Having said that, we do have a sizable number of personnel UTCs assigned to support all the AEFs.
49. Officers need to make rank on their own, not by stepping all over NCO's. Close the pay gap between Officers and Enlisted. We do the work.
50. I think the EAF concept is good but I thought it was for a more rapidly deployable Air Force not this 15 month rotation. Yes it makes it easier to plan things but even then the squadron doesn't plan for it. They just tell you about it. I have been on a...*

51. AEF's are a great concept except for the short notice back-fills you have to pull for other bases.
52. Before the AEF, I was not tasked to deploy as a 9-level. Since the AEF I have been tasked from March to June of each of the last 2 years and next year my wife who is also a 9-level in the same career field is tasked for the same time-frame. Knowing when...*
53. Overall, I'm sick and tired of the hypocrisy that I have witnessed over a span of almost 20 years. Amazingly enough I've seen it from year one to now on a continuing basis. Would the same type of problems occur in a different job?? Maybe. But my ending...*
54. I love the USAF and my current job. Even as a new Lt, I've had no problem managing my AF career with life. Despite my hectic office hours and TDY schedule, I am taking classes at night. And since my recent engagement to another AF officer, I've found th...*
55. I enjoy my job in the Air Force, but I feel as if the Air Force does not really care about me. I am here to do what they need and after I am no longer needed, I am no longer wanted.
56. The AF is not a bad place to get your life started. But as a family man with young children, sometimes the money is not there and that's when you start thinking and realizing you could make more money in the civilian world. Even though you might be happy...*
57. I feel as if a majority of the questions were directed towards the civilian side of the AF. If the questions are to get the opinion of military personnel, the questions should be more specific towards military life. The first part of the questionnaire is okay...*
58. The only problem that I see in today's Air Force in my AFSC is limited Base choice, I would love to see the Air Force go to a General AFSC for Fighter Crew Chiefs. It would be better all they way around I think as the F-16 Crew Chiefs would not be so taske...*
59. This survey weights emotional attachment to the USAF too heavily--as if you aren't passionate about the AF, then you can't possible be satisfied with it as part of your life. There is way more gray there than I think you are going to get with this survey.
60. The Air Force was good for me, but this does not apply anymore. Times have change, the economy has change. The benefits that the Air Force has do not compensate for what I will be earning on the outside. I can not continue having a career where earning...*

61. As an instructor at Keesler I must interact differently with Non-Prior service students, compared to how I must act with prior service students while TDY. That is why my answers on some questions are opposite (TDY compared to Non-TDY).
62. I like the Air Force and enjoy serving my country. I would like to stay in, but I am not able to provide a quality lifestyle for my family on enlisted military pay.
63. With the exception of the 1.5 yrs in Grad School, I've spent all my AF time on MAJCOM Staffs as a 61S. While I don't have to deal with deployments, I have not truly experienced the AF. Furthermore, most people do one staff tour --which they typically do...*
64. I'm single, so the family questions don't really apply to me. That's the one thing that keeps me from feeling like I'm "part of the Air Force family." I'm tagged for every survey, and instead of asking the demographics questions up front, and using thos...*
65. As a manager, my job in garrison, in CONUS, drains enough of my soul -- I take seriously the responsibilities of being an officer and of my job, and that inevitably detracts from my ability to emotionally commit as much as I would like to my family. Whe...*
66. I've enjoyed my Air Force career; however, the philosophy of "doing more with less," begins to wear on you after a while. My greatest frustration is not having the time to complete all tasks to the best of my ability. Too much rushing is required to...*
67. Most of the questions were not, in my opinion, adequately answered by the range of selections of simplified choices provided. I am a first term airman who is not happy with his own personal situation in the USAF, though I am not unhappy with the AF as a w...*
68. I feel the Air Force is lost ... and needs to be found again. We have just only recently discovered that we have cut too much, had the wrong priorities, focused on the personal traits that do not mean mission accomplishment.
69. The changes within the AF from '89 to date, have removed the closeness and enjoyment I experienced in my early years. The senior leadership seems more superficial and insincere than before. It has become more self-centered than before. If the AF would be...*
70. I often find myself having a hard time to complete my studies for up-grade training and go to school at the same time (CCAF is mandatory here at the Fire School). Also I must make time to stay fit for the Air Force's new PT program which I think is a grea...*

71. Been in the joint world since '86 - have never deployed anywhere for the USAF. Enjoyed being in and identified strongly with the DoD mission, but am not especially interested in AF OPs, and retirement is a real possibility, whenever the right conditions.
72. Responses were based on tempo in my job at home station. "Family" responses are how I would respond if I had a family ... I don't have one. But, I feel the amount of time I end up putting into the job to accomplish the mission seriously impacts my abili...*
73. Problem: the Air force does not look at the capabilities of an individual or there qualifications. They will move a trained individual into a job they have never done, and move someone else into the job that the individual was spent thousands of dollars...*
74. My uncertainty about the job schedule in the next 15 months is due to my volunteering for a job I don't know if I'll get. The only reason I don't feel completely part of the AF family right now is my assignment to AFRL. There is not the same feeling as...*
75. The AEF has made it easier for units assigned to an AEF, but not for those of us who are not. We continue to get short notice taskings for various operations, giving people less than 30 days notice. It seems that the manpower pool is made up from most i...*
76. The dissatisfaction I indicated in my job is more with my career field as a whole, rather than with my current job. I've looked at retraining opportunities, but with a newborn have decided not to pursue them at this time.
77. I like my job and believe totally in the military I am serving in however, the personnel cuts that have been made by our government have created a lot of stress in my particular AFSC. We do not have enough people to do the job. I have talked to counter...*
78. As a physician, the Air Force, or the military as a whole, does not have a clue how to treat us, or how to use us. There are no surgeons, that are any good, that would imagine continuing a career in the military, where you are constantly hassled, and pr...*
79. I have yet to see the benefit of the AEF concept. While I may not have been physically tasked myself, our unit continually deploys personnel with sporadic breaks in between. We currently have six deployed and we are preparing to deploy an additional six...*
80. Some of the answers given are due to a pending PCS within 4 months. New assignment is to Beale AFB, CA

81. I am currently on a short remote tour. The number of days TDY and deployed for me are NOT indicative of most pilots.
82. My job here in AETC does not include TDYs, so for the section on how I feel while TDY, I can't answer even though I was required to.
83. Perhaps this survey would be better filled out by someone who deploys.
84. The majority of this survey really didn't apply to me because I am in the C-130 Formal Training Unit as an Instructor, so we don't go TDY often and I will retire in approx. 2.5 years.
85. My unit isn't a part of the EAF concept; so it does little to help planning purposes. The majority of my TDY's and Deployments are unscheduled and often no-warning (avg. 3-6 days notice). While we can volunteer to fill AEF billets, some of the billets we...*
86. The AEF/EAF concept is an extraordinary fix to something that is not and has not been broken. When applied to Air units I can see the benefits. During a recent TDY to PSAB I saw the same air crews rotate in and out a few times. For base support personn...*
87. If you want more people to stay in the Air Force, especially in the F-16 career fields, then remote assignments to places like Korea need to go. Deployments to the Middle East are no problem, it's the remotes to Korea that makes a career in the Air Forc...*
88. I had a hard time with the family questions because I have no family to apply them to because even when I am not TDY, I have no family nearby. I'm not sure how well my answers will serve you, because I know the folks in my area with families have a major...*
89. While this survey concentrates on EAF deployments, there is a small but significant portion of the ADAF population that is stationed at a remote location...essentially deployed for 12 months. If you are truly seeking responses from all ADAF members who a...*
90. The question, "Would you leave if you found a better job?", I answered slightly disagree because I am retirement eligible and need to be considering my future options. I don't believe I will be in USAF in 5 years.
91. I am surprised there are no questions about military married to military relationships and how that may effect one's relationship and family life.

92. I answered based mostly off my previous experiences while stationed at Spangdahlem, which needless to say, has a very big TDY/Deployment plate. Being gone on the average of 30 days every couple of months or so caused serious problems in my married life, ...*
93. I would like to be paid \$55,000 a year excluding benefits.
94. This has been the most difficult, unrewarding job I've had since being in the AF. Senior leadership does not care about what's going on with their folks. It seems they only care about themselves and getting promoted. The morale/satisfaction of their subo...*
95. I have really enjoyed my last four years in the Air Force and have learned an incredible amount. I will be getting out of the Air Force for reasons that have nothing to do with the Air Force lifestyle, my job satisfaction, pay, or my family life.
96. I just PCS'd to an Air Logistics Center where we don't deploy very often at all. I cam from a Low-Density/High Demand airframe (U-2) that does not really fall under the EAF concept. U-2s maintain operating locations worldwide 365 days a year. They are...*
97. I was previously assigned to pope AFB and that is where all of my TDY and deployment answers came from. I was TDY for a total of 210 days in a 365 day time period. That is why I PCS'd from there to an AMC base there are less TDY's at this base...*
98. I believe the Air Force has gone from one extreme to another by. Before DESERT SHIELD/STORM the AF conduct little to no readiness exercises and rotations; now it is overbearing. I could understand having readiness exercises every quarter, if we had lost
99. I'm retiring in 7 months and some of my responses will probably skew your results.
100. The problem isn't the EAF concept. I think the concept would be successful if the military had sufficient funds, manpower and equipment. We are not prepared to fight two major conflicts simultaneously - I'm not talking about Desert Storm or a small poli...*
101. I will be married soon. She has two daughters. Cross training is heavy on a lot of the folks' minds here in Transportation.
102. Questions assume the option to stay in and do not allow for members with approved retirement orders.
103. 1st dependent lives with my ex-wife.

104. I don't believe there is the same sense of obligation or commitment in the Air Force that there was, say, 15 years ago when I came in. We were a team then. Now, it seems most people do the bare minimum required to get by. There is no sense of quality o...*
105. The service has changed a lot since I came in. I feel it is better but the kids today need to shut up and do their job instead of whining. We are focusing too much on making things sweet for them because the nature of what we do is to travel and be gone...*
106. Without any further explanation, I think my survey results might skew the results or give an inaccurate picture of my views. First, I am a Squadron Section Commander in a large SF unit. As such, members of my squadron deploy all the time, but I am not p...*
107. Being part of an AEF I think is a good idea for most squadrons. I am part of a rescue unit we do extra rotations at times but I guess it comes with the job. I think the Air Force is doing well trying to schedule when a unit is gone I don't think any oth...*
108. The AEF deployment I was involved in really made me question why I was in the Air Force. I was excited to deploy, but only discovered that the way we operate, the precedents being set, lack of support for the real mission, uncaring attitudes, and the ina...*
109. The AEF has made it easier for units assigned to an AEF, but not for those of us who are not. We continue to get short notice taskings for various operations, giving people less than 30 days notice. It seems that the manpower pool is made up from most i...*
110. The EAF process is not well defined, and there is still too much confusion as to what is going on. Additionally, people are still being double tasked when they return home they don't shortfall the other commitments of additional EAF tasking, they will pul...*
111. I think there is a serious morale problem with the young enlisted crowd. People ask, Why? Well I'll tell you why I feel the way I do. First on the list, I work in an environment with a 50/50 O/E ratio. I feel we're (E1-E4) under rewarded for the jobs we acco...*

Bibliography

- 1999 USAF careers and new directions surveys. (1999). Randolph Air Force Base, TX: Air Force Personnel Center.
- Adams, J. S. (1963). Toward an understanding of inequity. Journal of Abnormal and Social Psychology, 67 (5), 422-436.
- AEF notification. (Official Correspondence) (2000, May). Washington, DC: Headquarters, United States Air Force. Available at:
<https://aefcenter.acc.af.mil/AEFMessages/R111343ZMAY00.htm>
- Aerospace expeditionary force: introductory briefing (Presentation Slides) (2000). Langley Air Force Base, VA: Aerospace Expeditionary Force Center.
- Air Force Manual 10-100. (Field Manual) (1999). Washington, DC: United States Air Force.
- Allen N. J., & Meyer, J. P. (1990). The measurement and antecedents of affective, continuance, and normative commitment to the organization. Journal of Occupational Psychology, 63, 1-18.
- Buchanan, T. & Smith, J. L. (1999). Using the Internet for psychological research: Personality testing on the world wide web. British Journal of Psychology, 90, 125-144.
- Cammann C., Fichman, M., Jenkins G. D. JR., & Klesh, J. R. (1983). Assessing attitudes and perceptions of organizational measures. In Seashore, S.E., Lawler E.E., Mirvis, P. H., Cammann, C. (Ed.) Assessing Organizational Change: A Guide to Methods, Measures, and Practices (pp. 71-138). New York: Wiley.

Commanders' NOTAM 00-1: Expeditionary aerospace force update. (2000).

Washington, DC: United States Air Force.

Cooke R. A., & Rousseau, D. M. (1984). Stress and strain from family roles and work-role expectations. Journal of Applied Psychology, 69, 252-260.

Crampton, S. M., & Wagner, J. A. (1994). Precept-precept inflation in microorganizational research: An investigation of prevalence and effect. Journal of Applied Psychology, 79, 67-76.

Davis, R. G. (1998). Immediate reach, immediate power: the Air Expeditionary Force and American power projection in the post cold war era. Air Force History and Museums Program. Washington DC: United States Air Force.

Dooley, D. (1995). Social Research Methods, (3rd ed.). Upper Saddle River, New Jersey: Prentice Hall.

Dowdy, W. L. (2000). Testing the aerospace expeditionary force concept: An analysis of AEFs i-iv (1995-1997) and the way ahead (Research Paper). Maxwell Air Force Base, AL: Airpower Research Institute; College of Aerospace Doctrine, Research, and Education; Air University.

Edwards, J. E., Rosenfeld, P., Booth-Kewley, S., & Thomas, M. D. (1996). Methodological issues in navy surveys. Military Psychology, 8 (4), 309-324.

Expeditionary aerospace force (Point Paper). (1999). Washington DC: Expeditionary Aerospace Force Implementation Division; Headquarters, United States Air Force.

Frone M. R., Russell M., & Cooper M. L. (1992-a). Antecedents and outcomes of work-family conflict: Testing a model of the work-family interface. Journal of Applied Psychology, *77*, 65-78.

Frone M. R., Russell M., & Cooper M. L. (1992-b). Prevalence of work-family conflict: are work and family boundaries asymmetrically permeable?. Journal of Organizational Behavior, *13*, 723-729.

Garamone, J. (1999). Operations tempo remains retention challenge. Air Force News, n. pag. Available at: http://www.af.mil/news/Aug1999/n19990819_991549.html.

General Accounting Office. (2000). Force structure: Air force expeditionary concept offers benefits but effects should be assessed (Report No. GAO/NSIAD-00-201). Washington DC: United States General Accounting Office.

Hulin, C. L., Roznowski, M., & Hachiya, D. (1985). Alternative opportunities and withdrawal decisions: Empirical and theoretical discrepancies and an integration. Psychological Bulletin, *97*, 251-273.

Jaccard J. & Wan C. K. (1996). Series: Quantitative Applications in the Social Sciences: Lisrel Approaches to Interaction Effects in Multiple Regression. (1996). Thousand Oaks, CA: Sage.

Kahn, R. L., Wolfe, D. M., Quinn, R. P., Snoek, J. D., & Rosenthal, R. A. (1964). Conflict and Role Ambiguity Organizational Stress: Studies in Role. New York: Wiley.

Lance, C. E. (1991). Evaluation of a structural model relating job satisfaction, organizational commitment, and precursors to voluntary turnover. Multivariate Behavioral Research, *26* (1), 137-162.

Locke, E. (1976). The nature of job satisfaction. In M. D. Dunnette (Ed.) Handbook of Industrial and Organizational Psychology. Chicago: Rand McNally.

Nowak, M. J. (1999). The airpower expeditionary force: a strategy for an uncertain future?. Unpublished masters thesis, Air War College, Air University, Maxwell Air Force Base, Al.

Pursuing predictability: USAF's new deployment structure eases its combat units' high OPSTEMPO. (2000, February). Armed Forces Journal International, pp. 52-56.

Rizzo, J. R., House, R. J., & Lirtzman, S. I. (1970). Role conflict and ambiguity in complex organizations. Administrative Science Quarterly, 15, 150-163.

Rothausen, T. J. (1999). 'Family' in organizational research: A review and comparison of definitions and measures. Journal of Organizational Behavior, 20, 817-836.

Rousseau, D. M. (1998). The 'problem' of the psychological contract considered. Journal of Organizational Behavior, 19 (special issue), 665-672.

Rousseau, D. M. & Tijoriwala, S. A. (1998) Assessing psychological contracts: Issues, alternatives, and measures. Journal of Organizational Behavior, 19 (special issue), 679-695.

Schmit, M. J., Ryan, A. M., Stierwalt, S. L. & Powell A. B. (1995). Frame-of-reference effects on personality scale scores and criterion related validity. Journal of American Psychology, 80, 602-620.

Schnaible, E. (2000, June 8). Air Force EAF implementation director provides update. Air Force News, n. pag. Available at:

http://www.af.mil/news/jun2000/n20000608_000870.html

Segal D. R., Rohall, D. E., Jones, J. C., & Manos, A. M. (1999). Meeting the missions of the 1990s with a downsized force: Human resource management lessons from the deployment of patriot missile units to Korea. Military Psychology, 11 (2), 149-167.

Smith, P. C., Kendall, L. M., & Hulin, C. L. (1969). The Measurement of Satisfaction in Work and Retirement. Chicago: Rand McNally.

Spector, P. E. (1997). Job satisfaction: Application, assessment, causes, and consequences. Thousand Oaks, CA: Sage.

Stanton, J. M. (1998). An empirical assessment of data collection using the internet. Personnel Psychology, 51, 709-725.

Stevens, G. K. & Sommer, S. M. (1996). The measurement of work to family conflict. Educational and Psychological Measurement, 56, 475-486.

Sweetman, B. (2000, May). Expeditionary USAF sets course. Jane's International Defense Review. p. 30.

Tett, R. P., & Meyer, J. P. (1993). Job satisfaction, organizational commitment, turnover intention, and turnover: path analyses based on meta-analytic findings. Personnel Psychology, 46, 259-293.

Washington: Improving job satisfaction. (2000, May 22). The Air Force Times, p. 6.

Wayne, S. J., Shore, L. M., & Liden, R. C. (1997). Perceived organizational support and leader-member exchange: A social exchange perspective. Academy of Management Journal, 40, 82-111.

Webster's Dictionary, (2nd Ed.). (1998). New York: Random House.

Vita

Captain Patrick J. Obruba was born on 31 December 1973 in Greensburg, Pennsylvania. He graduated from Hempfield Area High School, also in Greensburg, Pennsylvania, in June 1992. He was appointed to the United States Air Force Academy and completed undergraduate studies at that institution. He graduated from the Academy with a Bachelor of Science degree in Civil Engineering in May 1996. He was subsequently commissioned a regular officer in the United States Air Force.

His first assignment was with the 88th Civil Engineer Group (CEG) at Wright-Patterson Air Force Base, Ohio in August 1996. While with the 88th CEG, he served as a facilities program manager for the Aeronautical Systems Center, Systems Program Offices (SPO) of the C-17, B-1, B-2, F-117, F-22 aircraft as well as the Engineering and Reconnaissance SPOs. During his tenure at Wright-Patterson, he deployed overseas in July 1998 to spend four months in Riyadh, Saudi Arabia where he served as the Engineering Flight Chief for the 4409th Civil Engineer Squadron (Provisional) in support of OPERATION SOUTHERN WATCH. In August of 1999, he entered the Graduate School of Engineering and Management, Air Force Institute of Technology. Upon graduation, he will be assigned to Kunsan Air Force Base, Korea.

REPORT DOCUMENTATION PAGE

Form Approved
OMB No. 074-0188

The public reporting burden for this collection of information is estimated to average 1 hour per response, including the time for reviewing instructions, searching existing data sources, gathering and maintaining the data needed, and completing and reviewing the collection of information. Send comments regarding this burden estimate or any other aspect of the collection of information, including suggestions for reducing this burden to Department of Defense, Washington Headquarters Services, Directorate for Information Operations and Reports (0704-0188), 1215 Jefferson Davis Highway, Suite 1204, Arlington, VA 22202-4302. Respondents should be aware that notwithstanding any other provision of law, no person shall be subject to a penalty for failing to comply with a collection of information if it does not display a currently valid OMB control number.

PLEASE DO NOT RETURN YOUR FORM TO THE ABOVE ADDRESS.

1. REPORT DATE (DD-MM-YYYY) 03-20-2001		2. REPORT TYPE Master's Thesis		3. DATES COVERED (From - To) Aug 1999- Mar 2001	
4. TITLE AND SUBTITLE PREDICTABILITY, WORK-FAMILY CONFLICT, AND INTENT TO STAY: AN AIR FORCE CASE STUDY				5a. CONTRACT NUMBER	
				5b. GRANT NUMBER	
				5c. PROGRAM ELEMENT NUMBER	
6. AUTHOR(S) Obruba, Patrick, J., Captain, USAF				5d. PROJECT NUMBER	
				5e. TASK NUMBER	
				5f. WORK UNIT NUMBER	
7. PERFORMING ORGANIZATION NAMES(S) AND ADDRESS(S) Air Force Institute of Technology Graduate School of Engineering and Management (AFIT/EN) 2950 P Street, Building 640 WPAFB OH 45433-7765				8. PERFORMING ORGANIZATION REPORT NUMBER AFIT/GEE/ENV/01M-13	
9. SPONSORING/MONITORING AGENCY NAME(S) AND ADDRESS(ES)				10. SPONSOR/MONITOR'S ACRONYM(S)	
				11. SPONSOR/MONITOR'S REPORT NUMBER(S)	
12. DISTRIBUTION/AVAILABILITY STATEMENT APPROVED FOR PUBLIC RELEASE; DISTRIBUTION UNLIMITED.					
13. SUPPLEMENTARY NOTES					
14. ABSTRACT A survey was completed by 362 active duty Air Force members in December 2000 regarding their perceptions of schedule predictability, work-family conflict, job satisfaction, organizational commitment, and intent to stay with the Air Force. Theory suggests that a program designed to create schedule predictability, the Expeditionary Aerospace Force (EAF), would moderate the relationship between predictability and intent to stay. Using Structural Equation Modeling (SEM), plausible evidence was found to support the idea that schedule predictability plays a role in intentions to stay via work-family conflict, job satisfaction, and organizational commitment. Additional evidence supported the theory that the path relationships generated via SEM changed in strength for demographic sub-categories based on the presence of dependent family members, but not for sub-categories based on assignment under the EAF.					
15. SUBJECT TERMS Personnel Management, Human Relations, Officer Personnel, Enlisted Personnel, Job Satisfaction, Retention, Air Force					
16. SECURITY CLASSIFICATION OF:		17. LIMITATION OF ABSTRACT UU	18. NUMBER OF PAGES 123	19a. NAME OF RESPONSIBLE PERSON Maj Michael T. Rehg, USAF, Assistant Professor, ENV	
a. REPOR T U	b. ABSTR ACT U			c. THIS PAGE U	19b. TELEPHONE NUMBER (Include area code) (937) 255-3636, ext. 4711

Standard Form 298 (Rev. 8-98)
Prescribed by ANSI Std. Z39-18

Form Approved
OMB No. 074-0188