

**SPEC**inc



stratton park engineering company inc  
cloud physics and instrumentation

**“Characterization of Aerosol Inlets and Ducts”  
Topic No. N01-047  
30 Day Progress Report**

**R. Paul Lawson, Principal Investigator**

**SPEC, Inc.  
3022 Sterling Circle, Suite 200  
Boulder, CO 80301**

**Contract No. N00014-01-M-0122  
(Unclassified)  
Office of Naval Research**

**For the Period 1 May 2001 – 31 May 2001**

**NOTE: Approved for public release; SBIR report, distribution unlimited.**

**20010615 122**

## 1. Description of Progress

As mentioned in the Phase I proposal, the inlet calibration device will utilize two windows inserted into the beam path of the FSSP 100/300. The purpose of these windows is to allow optical access to the particles flowing through the tubing from the aerosol inlet to the instrumentation in the cabin. The effect of the windows on the FSSP measurements needs to be understood to determine if the sizing calibration of the FSSP will be affected.

As a first order approximation, inserting a plane parallel plate after a lens will longitudinally displace the focus of that lens. The longitudinal shift in focus,  $d$ , is given by

$$d = \frac{(N-1)t}{N}$$

where  $N$  is the index of refraction of the window material and  $t$  is the thickness of the window. **Figure 1** shows the displacement of the image resulting from inserting a plane parallel plate after a lens.

The FSSP 100/300 uses a lens with a focal length of 50/ 55 mm to concentrate the laser light scattered by a particle in the sample volume around the dump spot and onto the detectors. Inserting a window into the sample volume will effectively shift the sample volume from the center of the FSSP sample tube toward the laser side of the sample tube. A thinner window will result in a smaller shift in the sample volume. Sapphire windows are a good choice because their high strength allows a relatively thin window to be manufactured. Esco Products, Inc. manufactures Sapphire windows as thin as 0.5 mm with diameters of 6.25 mm and 9.62 mm. For Sapphire,  $N=1.766$  at a wavelength of 633 nm. Using  $t=0.5$  mm and  $N=1.766$  in the above equation, this results in a longitudinal shift in the sample volume of approximately 0.217 mm away from the center of the sample tube.

The dump spot and aperture in the FSSP 300 are sized to collect scattered light between approximately  $4^\circ$  and  $12^\circ$ . The theoretical Mie curve used to determine the particle size is based on integrating the light scattered within these angles as a function of particle size. Based on the first order approximation above, the light rays passing through plane parallel plate will have the same angle before and after hitting the plate. Therefore, the collection optics of the FSSP should still collect light scattered between  $4^\circ$  and  $12^\circ$  from the center of the displaced sample volume. More work needs to go into this area to determine if this first order approximation is valid or if more detailed optical analysis needs to be performed using Zemax™.

The windows used will most likely be anti-reflection (AR) coated to reduce the scattered light from the windows from reaching the detectors. The AR coating will decrease the reflective losses of the laser beam intersecting the four Sapphire/air

interfaces. The transmission of Sapphire at 633 nm is approximately 85%. The intensity of the scattered light signal reaching the detectors will therefore be reduced by the addition of the two windows by  $(0.85)(0.85)=0.722$ . It is yet to be determined if this loss in signal needs to be compensated for. Possible approaches may be to increase the laser power, increase the gain downstream of the detectors, or to apply a scaling factor to the data in post processing.

Preliminary work has begun on the mechanical design of the inlet calibration device. **Figure 2** is a preliminary design of the inlet calibration device from the Phase I proposal. A market search is being conducted to determine if commercially available tubing fittings exist that can be used to couple the inlet calibration device to the conductive silicone tubing. The fittings must have the same inner diameter as the tubing so the flow is not disturbed as it passes through the device. Custom fittings will be designed if commercial fittings cannot be found.

Another aspect of the design being considered is that the inlet calibration device must be oriented so the windows are perpendicular to the laser beam throughout the full range of translation. If the device tilts while at different locations in the sample tube, it will steer the laser beam slightly, as well as the scattered light from particles in the sample volume. This misalignment could result in some signal being present on the detectors in the absence of particles as well as an error in the sizing of particles. The inlet calibration device must be designed so the translator, sampling tube, and FSSP sample tube maintain their orientation to each other at all times. Simply translating the device through its range of motion in the absence of particles and looking at the output of the instrument will verify if the inlet device is creating a false signal because it is misaligned.

## **2. Work to be completed during the next period**

During the next period, more effort will go into determining the effect of the windows on the FSSP measurement. If necessary, detailed ray tracing will be performed to determine the new scattering angles collected. The theoretical Mie curve will be generated for these new angles and compared with the existing curve. This information will assist in interpreting the data from the laboratory tests.

More effort will be spent on completing the mechanical design for the inlet calibration device over the next period. After the design is complete, detailed parts drawings will be generated and any vendor supplied items will be purchased. The SPEC owned FSSP will become available for laboratory testing over the next period. SPEC will also pursue obtaining an FSSP 300 to be used for laboratory testing of the inlet calibration device.

### **3. Total Cumulative Costs as of Report Date**

Cumulative costs expended through May 31, 2001 total \$4,730.11; direct labor of \$2,235.40 and indirect costs of \$2,494.71.

### **4. Estimate of Cost to Complete the Contract**

Physical completion of the contract is estimated for an additional 93% of effort.

Prepared by:

Patrick Zmarzly, Optics/Mechanical Systems Engineer  
Ph: (303) 449-1105 Fax: (303) 449-0132  
pzmarzly@specinc.com

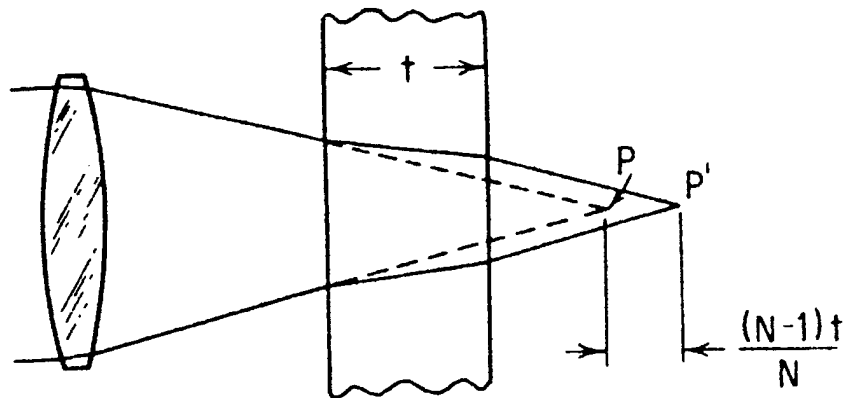

**Figure 1.** Longitudinal displacement of an image by a plane parallel plate.  
 (taken from *Modern Optical Engineering*, 2<sup>nd</sup> edition, Warren J. Smith, 1990.)

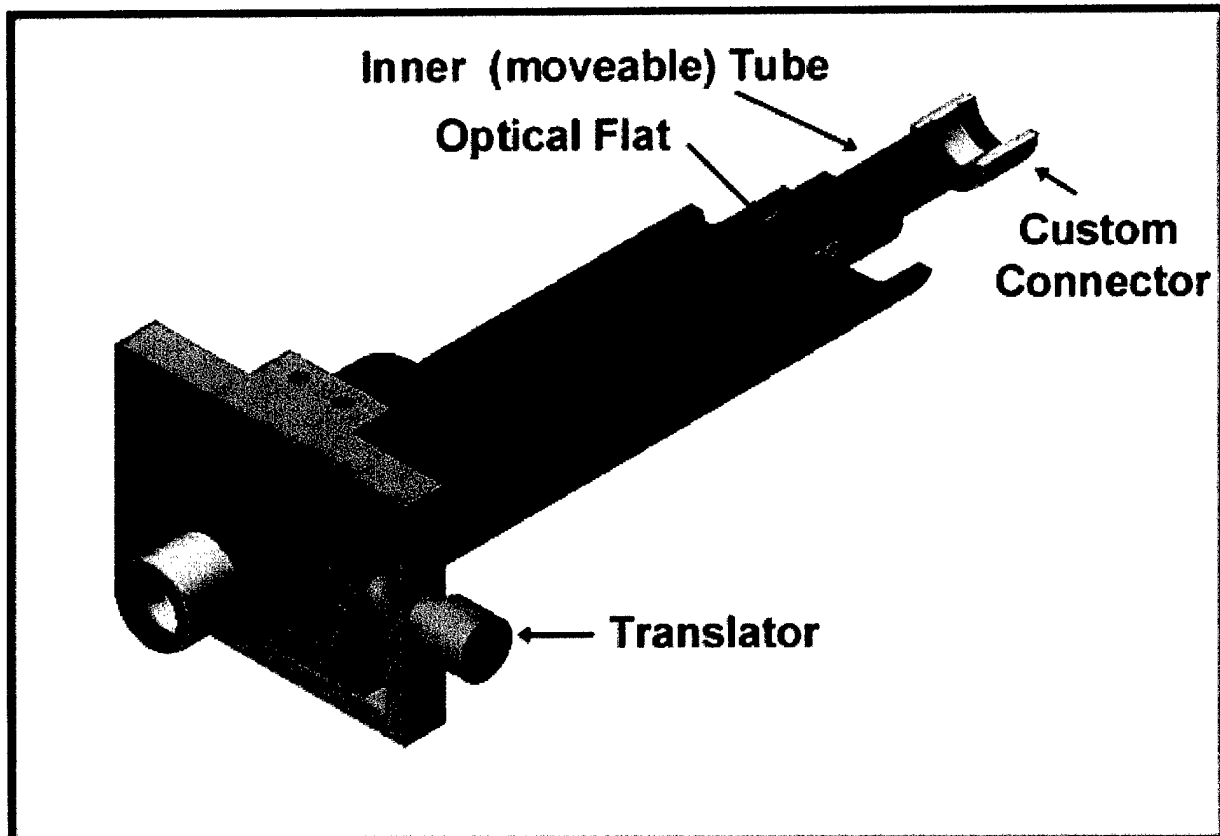

**Figure 2.** Preliminary design of inlet calibration device from Phase I proposal.

# REPORT DOCUMENTATION PAGE

Form Approved  
OMB No. 0704-0188

Public reporting burden for this collection of information is estimated to average 1 hour per response, including the time for reviewing instructions, searching data sources, gathering and maintaining the data needed, and completing and reviewing the collection of information. Send comments regarding this burden estimate or any other aspect of this collection of information, including suggestions for reducing this burden to Washington Headquarters Service, Directorate for Information Operations and Reports, 1215 Jefferson Davis Highway, Suite 1204, Arlington, VA 22202-4302, and to the Office of Management and Budget, Paperwork Reduction Project (0704-0188) Washington, DC 20503.

PLEASE DO NOT RETURN YOUR FORM TO THE ABOVE ADDRESS.

1. REPORT DATE (DD-MM-YYYY) June 14, 2001		2. REPORT DATE TYPE Progress		3. DATES COVERED (From - To) 1 May - 31 May, 2001	
4. TITLE AND SUBTITLE "Characterization of Aerosol Inlets and Ducts"				5a. CONTRACT NUMBER N00014-01-M-0122	
				5b. GRANT NUMBER N/A	
				5c. PROGRAM ELEMENT NUMBER N/A	
6. AUTHOR(S)  Patrick Zmarzly				5d. PROJECT NUMBER N/A	
				5e. TASK NUMBER N/A	
				5f. WORK UNIT NUMBER N/A	
7. PERFORMING ORGANIZATION NAME(S) AND ADDRESS(ES)  SPEC, Inc. 3022 Sterling Circle, Suite 200 Boulder, CO 80301				8. PERFORMING ORGANIZATION REPORT NUMBER  30 Day Progress Report	
9. SPONSORING/MONITORING AGENCY NAME(S) AND ADDRESS(ES)  Office of Naval Research ONR 253 JROFRANO Ballston Tower One 800 North Quincy St., Arlington, VA 22217-5660				10. SPONSOR/MONITOR'S ACRONYM(S)  ONR	
				11. SPONSORING/MONITORING AGENCY REPORT NUMBER  N/A	
12. DISTRIBUTION AVAILABILITY STATEMENT  Approved for Public Release; SBIR Report, Distribution Unlimited.					
13. SUPPLEMENTARY NOTES					
14. ABSTRACT  During the first thirty days of the Phase I project, preliminary calculations were performed to determine the effect of inserting windows into the FSSP sample volume. Based on a first order approximation, the windows will displace the FSSP sample volume away from the collection optics by 0.217 mm. A more detailed analysis will be performed to determine how the scattered light collection angle will be affected by the windows. Altering the collection angle may require generating a different theoretical Mie curve to determine particle size. Work has started on the mechanical design of the inlet calibration device. Candidate sapphire windows have been located and plumbing fittings are being investigated. An appropriate scheme to translate the device is also in progress. The optical work and final mechanical design for the inlet calibration device will continue during the next period.					
15. SUBJECT TERMS					
16. SECURITY CLASSIFICATION OF:			17. LIMITATION OF ABSTRACT	18. NUMBER OF PAGES  6 (incl SF298)	19a. NAME OF RESPONSIBLE PERSON
a. REPORT	b. ABSTRACT	c. THIS PAGE			Paul Lawson, Principal Invest.
					19b. TELEPHONE NUMBER (Include area code) (303) 449-1105