



**AN ANALYSIS OF THE INTERACTION BETWEEN THE
J3 AND J4 WAR PLANNING STAFFS DURING THE
PHASES OF CRISIS ACTION PLANNING**

THESIS

Michael J. Colvard, Captain, USAF

AFIT/GLM/ENS/01M-06

**DEPARTMENT OF THE AIR FORCE
AIR UNIVERSITY**

AIR FORCE INSTITUTE OF TECHNOLOGY

Wright-Patterson Air Force Base, Ohio

APPROVED FOR PUBLIC RELEASE; DISTRIBUTION UNLIMITED.

20010619 016

The views expressed in this thesis are those of the author and do not reflect the official policy or position of the United States Air Force, Department of Defense or the U.S. Government.

AFIT/GLM/ENS/01M-06

AN ANALYSIS OF THE INTERACTION BETWEEN THE J3 AND J4 WAR
PLANNING STAFFS DURING THE PHASES OF CRISIS ACTION PLANNING

THESIS

Presented to the Faculty

Department of Operational Sciences

Graduate School of Engineering and Management

The Air Force Institute of Technology

Air University

Air Education and Training Command

In Partial Fulfillment of the Requirements for the
Degree of Master of Science in Logistics Management

Michael J. Colvard, B.S.

Captain, USAF

March 2001

APPROVED FOR PUBLIC RELEASE; DISTRIBUTION UNLIMITED.

AFIT/GLM/ENS/01M-06

AN ANALYSIS OF THE INTERACTION BETWEEN THE J3 AND J4 WAR
PLANNING STAFFS DURING THE PHASES OF CRISIS ACTION PLANNING

Michael J. Colvard, B.S.

Captain, USAF

March 1, 2001

Approved:

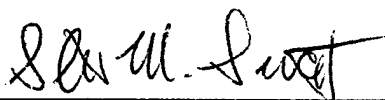

Stephen M. Swartz, (Advisor)

9 Mar 01
Date

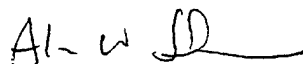

Alan W. Johnson, (Co-advisor)

9 MAR 01
Date

Acknowledgements

First and foremost, I would like to thank God for allowing me to experience this opportunity and for the mercy and strength to endure it. For the LORD giveth wisdom for the righteous: out of his mouth cometh knowledge and understanding (Proverbs 2:6). I also would like to thank God for blessing me with my wife and children. Their support has redefined the word commitment to me personally.

I would like to thank Major Swartz and Lieutenant Colonel Johnson for their support and counsel. There are a handful of students whom I owe extended thanks and appreciation: Paul Filcek whose knowledge and companionship made the knowledge gathering process tolerable; Chris Boone who provided unwavering support and sound advice; Steve Martinez who always kept me centered and focused; and finally Dave Wakefield who hung in there and battled toe to toe with me.

Michael J. Colvard

Table of Contents

	Page
ACKNOWLEDGEMENTS	iv
LIST OF FIGURES	vii
LIST OF TABLES	viii
ABSTRACT	ix
I. INTRODUCTION	1
BACKGROUND.....	1
PROBLEM STATEMENT	2
KNOWLEDGE MANAGEMENT	2
RESEARCH QUESTIONS	3
METHODOLOGY	4
ASSUMPTIONS	4
SCOPE/LIMITATIONS	5
SUMMARY	6
II. LITERATURE REVIEW	7
INTRODUCTION	7
BACKGROUND OF PROBLEM.....	7
CURRENT CRISIS ACTION PLANNING PROCESS AS DEFINED BY DEFENSE POLICY	12
EAF CONCEPT	20
TOOLS USED IN CURRENT PROCESS	21
ALP HISTORY.....	26
KNOWLEDGE MANAGEMENT	28
IDENTIFYING KNOWLEDGE	30
KNOWLEDGE ANALYSIS METHODS.....	32
KNOWLEDGE MAPPING	35
SUMMARY	35
III. METHODOLOGY	37
INTRODUCTION	37
IDENTIFICATION OF KNOWLEDGE CATEGORIES	37
<i>Interview Participants</i>	38
<i>Interview Analysis</i>	39
KNOWLEDGE AUDIT	40
<i>Questionnaire Development</i>	40
<i>Questionnaire Participants</i>	41
<i>Questionnaire Analysis</i>	41
COMPARATIVE ANALYSIS	43
SUMMARY	44

IV. RESULTS	45
INTRODUCTION	45
WHAT IS THE CURRENT CAP PROCESS ACCORDING TO SMES?	45
<i>Phase III, COA Development</i>	47
<i>Phase IV, COA Selection</i>	50
<i>Phase V, Execution Planning</i>	52
OTHER ISSUES FROM SME'S RESPONSES	54
HOW DOES THE CURRENT CAP PROCESS COMPARE TO WHAT ALP CAN DELIVER?	56
FUTURE AIR CAMPAIGN PLANNING	62
SUMMARY	64
V. CONCLUSION	65
INTRODUCTION	65
RESEARCH PHASES	65
CONCLUSIONS	66
LIMITATIONS	70
RECOMMENDATIONS OF FUTURE RESEARCH	71
SUMMARY	71
APPENDIX A: INTERVIEW BULLET BACKGROUND PAPER	73
APPENDIX B: INTERVIEW QUESTIONNAIRE	74
APPENDIX C: CHECKLIST FOR CAP PHASE III	75
APPENDIX D: CHECKLIST FOR CAP PHASE IV	77
APPENDIX E: CHECKLIST FOR CAP PHASE V	78
APPENDIX F: KNOWLEDGE MAP INDEX	80
APPENDIX G: KNOWLEDGE MAPS, CAP PHASES III-V	81
APPENDIX H: KNOWLEDGE MAPS, CAP PHASE III	82
APPENDIX I: KNOWLEDGE MAPS, CAP PHASE IV	91
APPENDIX J: KNOWLEDGE MAPS, CAP PHASE V	90
BIBLIOGRAPHY	99
VITA	104

List of Figures

	Page
FIGURE 1: JOINT PLANNING PROCESS.....	9
FIGURE 2: JOINT PLANNING SUMMARY.....	10
FIGURE 3: CAP PHASES III-V	12
FIGURE 4: THE JOINT PLANNING AND EXECUTION COMMUNITY	13
FIGURE 5: CAP PHASE III COA DEVELOPMENT.....	16
FIGURE 6: CAP PHASE IV COA SELECTION.....	18
FIGURE 7: PHASE V EXECUTION PLANNING.....	19
FIGURE 8: KNOWLEDGE HIERARCHY	29
FIGURE 9: IDEF MODEL	46
FIGURE 10: CURRENT PROCESS FOR PHASE III.....	49
FIGURE 11: CURRENT PROCESS FOR PHASE IV.....	52
FIGURE 12: CURRENT PROCESS FOR PHASE V.....	54
FIGURE 13: PHASE III OVERVIEW	56
FIGURE 14: PHASE III, TPFDD DEVELOPMENT	57
FIGURE 15: PHASE IV, PLANNING ORDER PUBLISHED	59
FIGURE 16: PHASE V OVERVIEW.....	60
FIGURE 17: PHASE V, EXECUTION PLANNING.....	61

List of Tables

	Page
TABLE 1: OVERVIEW OF SELECTED HANDS-ON METHODS	34

Abstract

A principal operational concept of Joint Vision 2020 is that of *Focused Logistics*, which promotes a merger of information and logistics technologies. The Defense Advanced Research Projects Agency's Advanced Logistics Project (ALP) supports this concept of *Focused Logistics* and seeks to leverage information technologies to obtain control over the logistics pipeline.

The current campaign planning process is limited by the information made available to the decision-makers. In order for ALP to assist the decision-maker in selecting a single optimal deployment plan, the founding assumptions of alternatives considered must be valid. Logistical issues are a major constraint in the war planning process. Often, when planners are faced with Crisis Action Planning (CAP) the interaction between the operations planners and the logistics planners is limited due to the time sensitivity of the situation. Because logistics information is a main constraint in the CAP process, operational planners build their plans based on limited logistics information and potentially inappropriate logistic assumptions.

This thesis will explore the contribution that ALP's architecture could bring to the crisis action planning process. The focus of this research is to analyze the interaction between the operational and logistical communities and determine the ideal planning tool that will enhance the communication between the two communities.

AN ANALYSIS OF THE INTERACTION BETWEEN THE J3 AND J4 WAR
PLANNING STAFFS DURING THE PHASES OF CRISIS ACTION PLANNING

I. Introduction

Background

A principal operational concept of Joint Vision 2020 is that of Focused Logistics, which promotes a merger of information and logistics technologies to enable a more mobile, versatile, and easily deployable joint force. The Defense Advanced Research Projects Agency's (DARPA) Advanced Logistics Project (ALP) supports this concept of Focused Logistics and seeks to leverage information technologies to obtain control over the logistics pipeline (Carrico: 1999). DARPA's development of an automated, multi-echelon, real-time cooperative information technology is intended to provide the logisticians and warfighters with an unprecedented capability to plan, execute, monitor, and rapidly rebuild campaign plans, as the campaign proceeds (Carrico: 1999). The Air Force Institute of Technology (AFIT) and the Air Force Research Laboratory (AFRL) are working together to develop a methodology for ALP that measures the relative value of each combat force mix alternative in relation to the logistics tail.

This thesis will identify the potential contribution that the ALP architecture could bring to the crisis action planning process. The aim of this research is to define the ideal

decision support tool for the campaign planner, and determine how ALP could help improve the existing process.

Problem Statement

The current campaign planning process is limited by the information made available to the decision-makers. In order for the Advanced Logistics Project to assist the decision-maker in selecting a single optimal deployment plan, the founding assumptions of alternatives considered must be valid. Logistical issues are a major constraint in the war planning process. Often, when planners are faced with Crisis Action Planning (CAP) the interaction between the operations planners and the logistics planners is limited due to the time sensitivity of the situation. Because logistics information is a main constraint in the CAP process, operational planners build their plans based on limited logistics information and potentially inappropriate logistic assumptions. The focus of this research is to assess the interaction between the operational and logistical communities and determine the value and characteristics of the ideal tool, enhancing the communication between the two communities. First we must describe a key term that will be used throughout this paper.

Knowledge Management

“Knowledge management involves the identification and analysis of available and required knowledge assets and knowledge asset related processes, and the subsequent planning and control of actions to develop both the assets and the processes so as to fulfill organizational objectives” (Macintosh: 1999). One approach to assess the interaction

between the operational and logistical communities is to capture the knowledge that exists in the campaign planning process. Knowledge can be used as a tool to help leverage the capacity that exists in an organization. Knowledge can be regarded as an asset that organizations possess or need to enhance operations. Knowledge management not only manages these assets, but the processes that act upon them. Processes that act upon knowledge assets include: developing knowledge; preserving knowledge; using knowledge; and sharing knowledge (Macintosh: 1999).

The difficulty in knowledge management arises with identifying the knowledge assets of an organization. The initial step in managing the knowledge assets in an organization or process is to first identify and categorize the knowledge. Once the organization's knowledge assets are identified and categorized, then knowledge management can begin. The war planning process involves the synthesis of knowledge from several different functional disciplines. The war planner possesses knowledge from doctrine and training. The war planner also possesses knowledge from past experiences. Functional knowledge from several other disciplines mix into the war planning process. The ALP architecture enables access to these areas of functional knowledge on a real-time basis.

Research Questions

The purpose of this research effort is defined by the overall research question: what knowledge must be shared between the operational planner (J3) and the logistics planner (J4) to optimally execute the crisis action planning process? To successfully complete this research project, the following investigative questions must be answered:

1. What is the process involved with the operational order (OPORD) generation?
2. What deployment planning, campaign planning, and operational order generation tools are used today?
3. What is the available knowledge in the CAP process?
4. What is the required knowledge in the CAP process?
5. To what extent does the value of ALP contribute to the CAP process, and where do the existing tools fall short?

Methodology

The methodology used in this research was conducted in three phases; knowledge identification, knowledge audit, and comparative analysis. The first phase of the research consisted of both archival review and content analysis (literature review), and in-person interviews with subject matter experts (SMEs) on the war planning process. The second phase involved email questionnaires to seek specific knowledge from joint air component planner's perspectives. This phase engaged a knowledge audit to capture the knowledge held by the war planner, the knowledge needed by the war planner, and the knowledge made available by the ALP architecture. The final phase compared the knowledge assets of the current CAP process with the knowledge assets that ALP can provide. This comparison was achieved by a knowledge analysis method called knowledge mapping.

Assumptions

This research is based on current Air Force doctrine and policies. Many of the concepts that ALP is developing are not constrained by the notional war planning ideas currently employed. The SME's validations of the weighted values assigned to aircraft to

mission taskings are based on current strategical and tactical philosophies. The following numbered Air Forces, major commands, and school houses took part in this study: Joint Staff J3, Checkmate Air Force Headquarters, Joint Forces Command (JFCOM), European Command (EUCOM), 12th Air Force Southern Command (SOUTHCOM), 9th Air Force Central Command (CENTCOM), Air Component Command (ACC), Special Operations Command (AFSOC), Air Expeditionary Force Center, Air Warfare Center USAF Weapons School, College of Aerospace Doctrine Research, and Education (CADRE), and the Air Force Command and Control Training and Innovation Group (AFC2TIG).

Scope/Limitations

While this research focused on the USAF perspective of war planning, a multi-national approach to war planning will need to be supported in future combat operations. The United States support of the North American Treaty Organization (NATO) involves USAF war planners coordinating with coalition forces to accomplish global objectives. Besides the interaction between coalition forces and USAF planners, the Air Force must consider the joint role of campaign planning interaction. Campaigns involve alternatives of actions that include any combination of service mixes. Planning in the joint environment is a major issue in cluster-based objective in ALPs architecture (Carrico: 1999). The results of this research can be used by the war planner as a dynamic decision support tool.

Summary

This chapter provided the background of defining, validating, and examining campaign specific decision support tools that assist the war planners in selecting the best mix of combat aircraft to accomplish the desired mission objectives.

Chapter II reviews Air Force doctrine, decision support tools currently employed, and the methodology used to elicit information from the SMEs. Chapter III describes in detail the methodology introduced in Chapter II and is used to accomplish a knowledge audit. Chapter IV displays the results of the knowledge audit and relational analysis. Chapter V provides conclusions and discusses what the ideal tool in the crisis action planning process would be.

II. Literature Review

Introduction

The air campaign planner's main objective is to provide the Commander-in-Chief (CINC) with a satisfactory set of combat aircraft that meet the required mission. ALPs goal is to converge operations and logistics information systems as an operational plan is executed. As Joint Publication 1 states, "logistics sets the campaign's operational limits." Without the proper linkage between the operations (J3) and logistics (J4) planners, the set of combat forces provided to the CINC results in less than optimal solutions. To expand the operational limits of a campaign, a collaborative effort must exist between the operations and logistics planners to ensure that the optimal alternative is provided to the CINC to meet the desired requirements.

Background of Problem

There is apprehension that the US defense planning process has difficulty in translating national-level policy guidance into feasible defense contingency plans, which, if implemented, create winning outcomes. These concerns are addressed in Carlson, Sierra, and King's paper, *Strategy, Policy and Contingency Planning: The US Defense Planning Process* (Carlson, et al: 1984). Some of these concerns center on planning outcomes such as: the aborted mission to rescue the American hostages in Iran; the 1975 Mayaguez rescue operation; the 1970 North Vietnam Sontay prison raid to free US prisoners of war; the Beirut terrorist bombing where 241 servicemen were killed; and even the successful 1983 Grenada invasion (hailed as a success, yet faulted for major

command and intelligence lapses) (Carlson, et al: 1984). Their study analyzed the current defense planning process, its current day viability, and its relationship with National Command Authority guidance. The authors interviewed key planning officials throughout the Departments of Defense and State and the National Security Council. Their study concluded that the US defense planning process is functioning; but not as specifically intended, and is in need of corrective action and direction, especially in the area of crisis contingency planning (Carlson et al: 1984).

The results of their study (in part) led to the Goldwater-Nichols DoD Reorganization Act of 1986. The act sought to improve joint operations and provided complete authority of the CINC over the subordinate forces within his command (Osgood: 1996). The act shifted the lines of authority for military forces within an unified command from the Joint Chiefs of Staff (JCS) to the CINC. Clear lines of authority lead to unification of the war planning effort. Osgood discusses how General Schwarzkopf had real command over his unified command during the war in the gulf for the first time in a major confrontation (Osgood: 1996). Unification in the war planning environment diminishes fragmented, uncoordinated strategy. The Goldwater-Nichols Act legally mandates *jointness* by statute (Osgood: 1996). Osgood emphasizes the need for unified command when he refers to General Eisenhower's slogan, "singly led and prepared to fight as one regardless of service" (Osgood: 1996). Similarly, unification of the crisis action planning process between the J3 and J4 will result in more successful execution. While the Goldwater-Nichols Act addressed joint operations and command and control, problems in the campaign planning process still exist.

The war planning process is categorized in two basic processes under campaign planning: deliberate planning and crisis action planning (Joint Pub: 5-0). Figure 1 shows the interrelated processes.

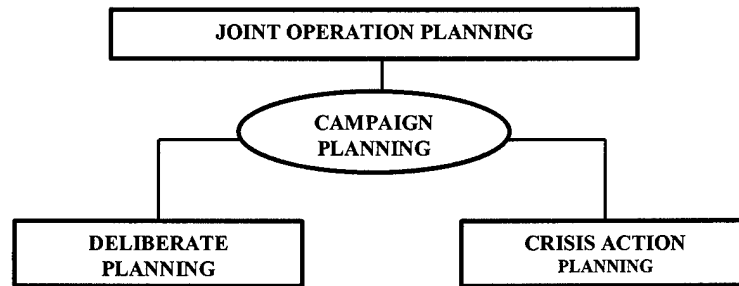

Figure 1: Joint Planning Process

Campaign planning encompasses both the deliberate and crisis action planning processes. Campaign planning begins with deliberate planning under peacetime operations and continues with crisis action planning as required. Deliberate planning involves the development of Operational Plans (OPLANs), usually during peacetime operations. Deliberate plans are accomplished in two-year cycles in accordance with the Joint Strategic Capabilities Plan (JSCP) (Joint Pub 5-03.1: 1995). The parameters of the JSCP process revolve around the annual defense budget and the current threats to national security at the present time. Due to the natural collaborative effort of deliberate planning, this research will focus on the interaction between the J3 and J4 planners during the more time sensitive process of crisis action planning. Crisis Action Planning is a set of procedures that provide guidance and procedures for joint operation planning by military forces during emergency or time sensitive situations (JOPES Vol I).

Defense policy defines the CAP process in Joint Publication 5-00.2. While deliberate planning is accomplished to anticipate future events, CAP was designed to respond to present situations that arise at a moments notice. Occasionally, the situation may be similar to those situations planned for in the deliberate planning process; however, it is not likely that it will be identical. A comparison of the two planning processes can be seen in Figure 2 (Joint Pub 5-00.2: 1999).

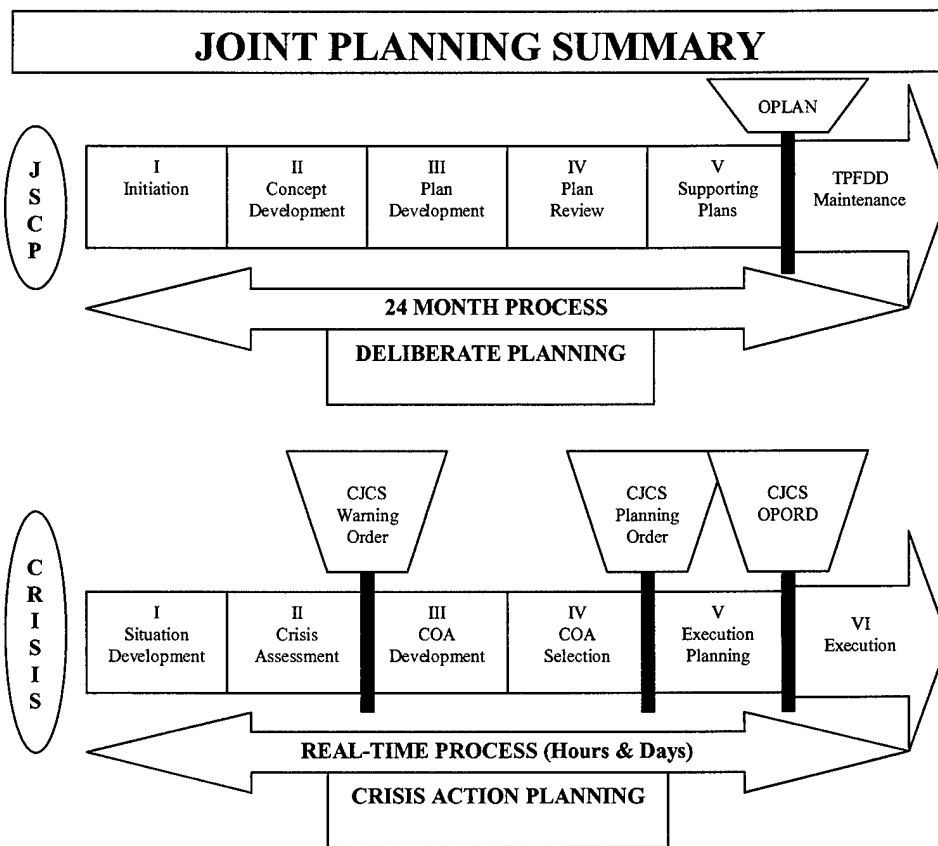

Figure 2: Joint Planning Summary

Deliberate planning begins with the Joint Strategic Capability Plan (JSCP). The JSCP apportions forces and resources based on political and military assumptions that

exist when the plans are implemented. JSCP is the primary vehicle used by the Chairman Joint Chiefs of Staff (CJCS) to exercise his responsibility in providing for joint operational plans (Joint Pub 5-00.2: 1999). This process involves the participation of the entire Joint Planning and Execution Community (JPEC). The deliberate planning process concludes with the development of operational plans.

The CAP process begins when a certain event or incident occurs and ends when the crisis is resolved or forces are withdrawn. The CINC reports the situation as it develops to the National Command Authorities (NCA) and the JCS. Depending on the time sensitivity of the situation, a Course of Action (COA) could be submitted along with the notification. After the event is reported, the NCA and JCS analyze the situation determining if a military option is required. The NCA demonstrates great flexibility in this phase of CAP. It has the options to wait for further information, progress to the next phase, or revert back to the pre-crisis posture (Joint Pub 5-00.2: 1999). If the NCA decides to progress to the next phase of CAP, it provides the strategic guidance for the joint operation planning and possible guidance for the COAs to be developed. It is at this point when a Joint Task Force (JTF) may be established, if one does not already exist (Joint Pub 5-00.2: 1999).

The majority of the planning process for CAP occurs during *COA Development*, *COA Selection*, and *Execution Planning* phases. It is for this reason that the author selected these phases of CAP for this research. An overview of these three phases is depicted in the Figure 3.

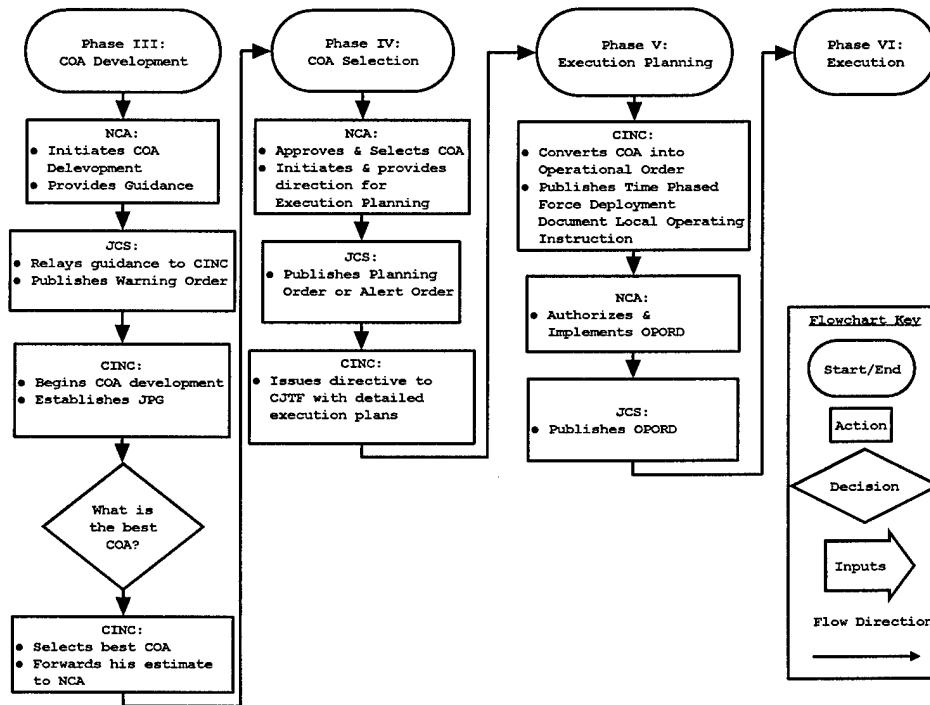

Figure 3: CAP Phases III-V

Current Crisis Action Planning Process as Defined by Defense Policy

Air Force Manual 1-1, Basic Aerospace Doctrine, establishes the framework for understanding how to apply military power. This manual applies equally to active military, reserve components, and civilians. Through the study of war, doctrine is derived (AFM 1-1: 1992). It offers guidance to Air Force leaders to learn from the past, to act in the present, and to influence the future. This doctrine lays the foundation for all Air Force policies that organize, train, equip, and sustain aerospace forces for war (AFM

1-1: 1992). It also describes the nature of combat support and its relationship to aerospace power.

Joint Publication 5-0 goes into further detail concerning the joint war planning environment. The JPEC consists of the CJCS, as well as other members of the JCS, the combatant commands and their command components, subunified commands, joint task forces, and Defense agencies (Joint Pub 5-0: 1995). JPEC's involvement in the planning process includes the mobilization, training, preparation, movement, reception, employment, and support of forces committed to a specific theater of war (Joint Pub 5-0: 1995). Figure 4, taken from Joint Pub 5.0, outlines the JPEC population.

The Joint Planning and Execution Community (JPEC)

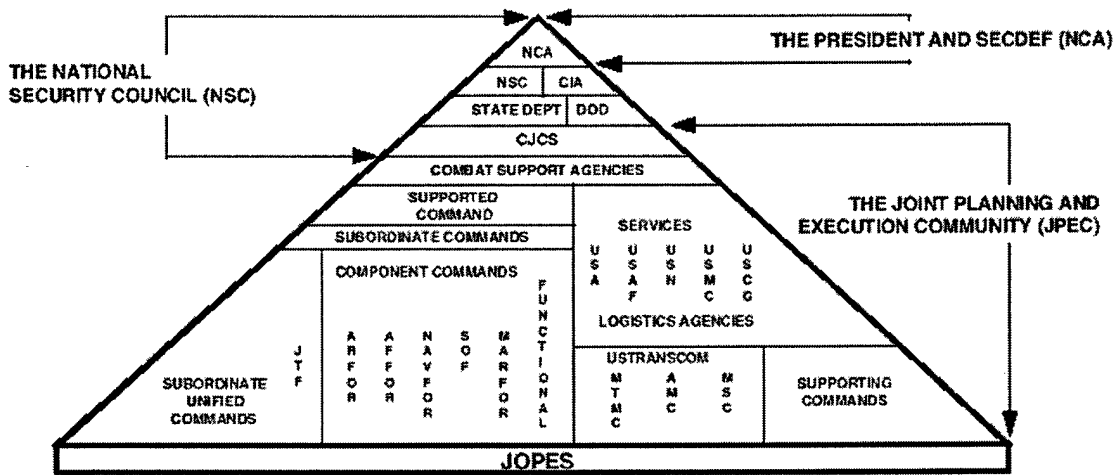

Figure 4: The Joint Planning and Execution Community

Depending on the time sensitivity of the crisis situation, the roles of the JPEC community vary. The CAP process is dynamic, with the body of knowledge evolving from minute to minute. Due to this dynamic process, this research seeks to capture this decision making process under three templates: as it is written, as it is actually

experienced, and how it could be improved with the application of ALP added to the process.

The JPEC uses the Joint Operation Planning and Execution System (JOPES) to conduct joint planning during peacetime and contingencies. The focus of the joint operational planning process is at the combat commanders level using JOPES to coordinate the best method of accomplishing the desired mission. This coordination includes the NCA, Chairman Joint Chiefs of Staff (CJCS), and all other support agencies in the JPEC. During peacetime operations this planning process, called deliberate planning, produces operation plans (OPLANs). In times of crisis, this planning process (CAP) produces operation orders (OPORDs). JOPES is designed to facilitate both the generation of OPLANs in deliberate planning and the rapid development of OPORDs built from existing OPLANs or NO-PLAN scenarios in CAP (Joint Pub: 5-0).

During crisis action planning, information is passed from the JCS to the NCA concerning decisions involving the use of US military forces. JOPES Vol. I defines a crisis as

... an incident or situation involving a threat to the US, its territories, citizens, military forces, and possessions or vital interests that develops rapidly and creates a condition of such diplomatic, economic, political, or military importance to the US government that commitment of US military forces and resources is contemplated to achieve US national objectives (JOPES Vol. I).

CAP consists of the following six phases:

- *situation Development*
- *crisis assessment*
- *course of action Development*

- *course of action selection*
- *Execution Planning*
- *execution*

Phase I of the crisis action planning process, *situation Development*, involves the supported command reporting a significant event to the National Military Command Center (NMCC). This report includes the CINC's assessment of the event, describing the nature of the crisis, forces available, major constraints, actions being taken, and courses of action being considered. This report is channeled through the CJCS, who evaluates the reports and the actions of the CINC, to the NCA.

Phase II involves *crisis assessment*. The NCA decides to develop the military course of action (COA). The CINC continues to report the status of the situation while reviewing existing OPLANs for applicability. The CINC can use an existing OPLAN, use it as a building block, or build a plan from the ground up. The CJCS gives the CINC's assessment to the NCA and continues to monitor and review the CINC's plans and actions.

The Joint Task Force (JTF) should be established prior to Phase III of the CAP process to allow maximum participation in as much of the process as possible. Once the JTF is established, a planning element should be formed to optimize the process. This planning element is commonly referred to as a Joint Planning Group (JPG).

The composition of the JPG varies depending upon the nature of the crisis and which command was involved. Generally, the JPG consists of representatives from the following functions: J1 (personnel), J2 (intelligence), J3 (operations), J4 (logistics), J5 (plans), J6 (communications), medical, staff judge advocate, and public affairs. Joint Pub

5-00.2 states that JPG representation should be long-term assignments to provide continuity and a small group of core planners with the authority to speak on behalf of their sections, components, or organizations (Joint Pub 5-00.2: 1999).

Phase III *course of action Development* begins when the NCA decides that military options are required to resolve the crisis. The directive, handed down by the NCA, establishes command relationships, identifies the mission, and provides any planning constraints (Joint Pub 5-00.2: 1999). Figure 5 displays the relationships between activities.

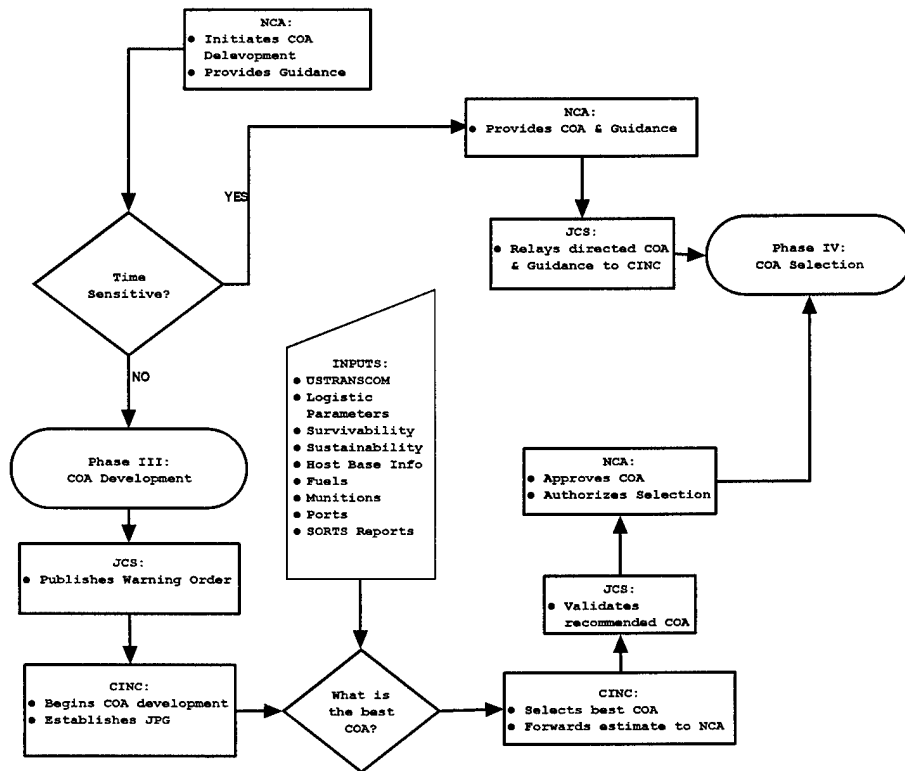

Figure 5: CAP Phase III COA Development

COAs can be developed from existing OPLANs, modified OPLANs, from the ground up, or as directed by the NCA. In the event that the NCA directs the development

of a specific COA, the directive will describe the COA and request the supported commanders assessment (Joint Pub 5-00.2: 1999). During this phase of CAP, the JCS publishes the Warning Order. The Warning Order gives initial guidance to the JPEC and requests that the CINC develops a recommended COA to meet the situation. Based on the CINC's guidance, Time Phased Force Deployment Data (TPFDD) development begins. TPFDDs are developed for each COA, time permitting. Supporting agencies review proposed COAs for feasibility and advance planning possibilities. Phase III ends after the supported CINC commander analyzes and submits the selected COA to the NCA and JCS.

Phase IV, *COA Selection*, begins when the NCA authorizes and selects the COA submitted by the CINC (Joint Pub 5-00.2: 1999). After the NCA decision, the CJCS issues an Alert Order. The Alert Order is approved by the Secretary of Defense and issued to the CINC and the rest of JPEC announcing the selected COA and directing the initiation of *Execution Planning*. The CJCS can issue a Planning Order to initiate *Execution Planning* prior to the selection of a COA by the NCA. Once the NCA selects a COA, the Secretary of Defense must approve the Planning Order. The CINC issues the directive to the Commander of the Joint Task Force (CJTF) to commence detailed *Execution Planning*. As the directives are passed down to the JTF components, they become more specific to each of the appropriate components. Phase IV of the CAP process is displayed in Figure 6.

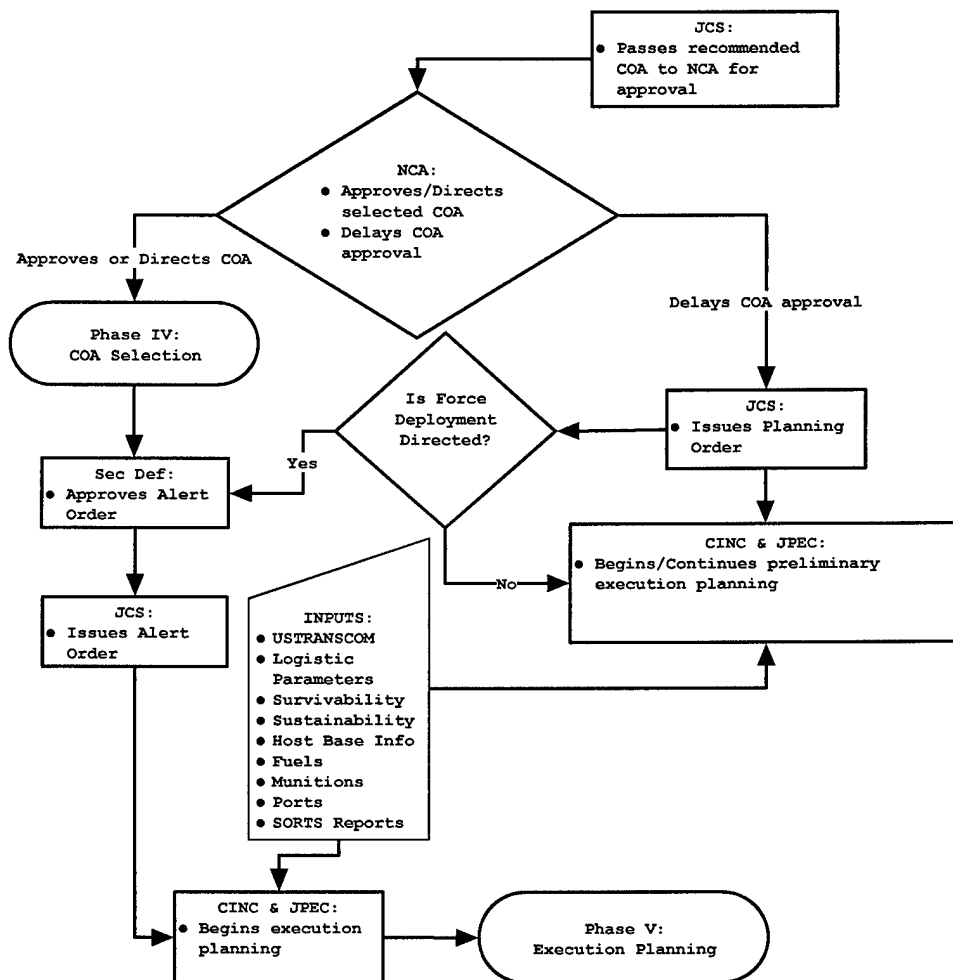

Figure 6: CAP Phase IV COA Selection

Phase V, *Execution Planning*, begins once the Planning or Alert Order is issued. The CINC transforms the approved COA into an Operational Order (OPORD). The CJTF develops an OPORD based on the CINC's OPORD. JOPES procedures are used in the development of the OPORD and the TPFDD (Joint Pub 5-00.2: 1999). The CJTF inputs unsourced force requirements into the appropriate TPFDD and validates the requirements through the supported CINC. JOPES and the other feeder systems that provide the planners with the required information are vital in this phase of planning.

The supported CINC validates the TPFDD to the Commander in Chief, United States Transportation Command (USCINCTRANS) (Joint Pub 5-00.2: 1999). Any changes to the TPFDD must be revalidated through the supported CINC and USCINCTRANS. The *Execution Planning* phase concludes when the NCA implements the OPORD (Joint Pub 5-00.2: 1999). Figure 7 captures the *Execution Planning* phase of CAP.

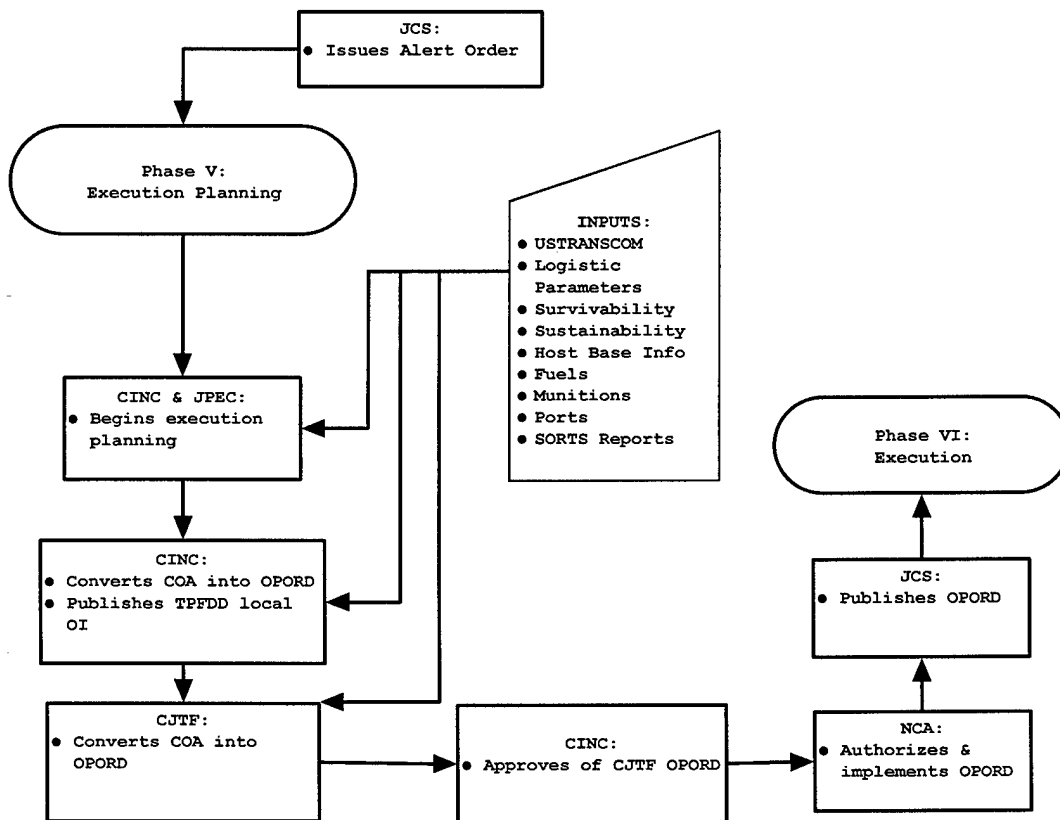

Figure 7: Phase V Execution Planning

A checklist for CAP Phases III-V is provided in Appendix C. The final phase (Phase VI) of the crisis action planning process is *execution*. Once the NCA authorizes the release of the Execute Order, the CJCS publishes the order. The Execute Order

directs deployment and employment of forces. The CINC executes the OPOD, monitors the force deployment, and controls the employment of forces.

The major difference between crisis action planning and deliberate planning is time sensitivity. Deliberate planning is a collaborative process and involves the supported CINC, JCS, supporting commands, and associated defense agencies. Senior officers conduct strategic planning at the JCS and CINC levels, but as the planning rolls down to the supporting commands the ranks and positions of planners vary. Many civilian planners are employed by the military to provide continuity and experience. Several of the civilian planners are prior active duty planners and operators. The role of enlisted planner is usually one that manages and operates the planning databases and systems, such as JOPES.

Due to the very nature of an unexpected crisis, time is of the essence and planning involvement becomes limited. Expedient planning and estimations rely heavily upon communication from the NCA down to the CINC and supporting commands. ALP's goal is to provide for rapidly available information at all levels of the planning process (Carrico: 1999). The EAF concept depends on timely and efficient support.

EAF Concept

The Air Force is divided into ten Air Expeditionary Forces (AEF), each roughly equivalent in capability, among which deployment responsibilities are rotated. Each AEF is required to be able to project highly capable and tailored force packages. Upon short notice, the AEF is tasked to respond anywhere around the world, to a wide range of possible operations, largely from the continental United States (CONUS). This concept

requires the ability to deploy and employ quickly, adapt rapidly to changes in the scenario, and sustain operations indefinitely. To meet the demanding timelines, units must be able to deploy and set up logistics production processes quickly. Deploying units will, therefore, have to minimize deployment support. This, in turn, demands the support system be able to ensure the delivery of sufficient resources when needed to sustain operations (Tripp: 1999). Support systems are plentiful in the joint planning environment. Integration and compatibility are major issues concerning support systems.

Tools Used in Current Process

Webster's defines a tool as "something used in performing an operation or necessary in the practice of a vocation or profession" (Merriam-Webster: 2000). The war planning process involves several different types of tools. These tools range from grease pencils and white boards to the latest in advanced technology. The interview phase of this research (presented later) will discuss the tools that are currently used.

The Joint Operation Planning and Execution System (JOPES) is the principal system used by the Department of Defense (DoD) that translates policy decisions into operational plans supporting national objectives. JOPES is the primary source for deployment/redeployment planning and execution resource information (Joint Pub 5-03.1: 1993). It is a means for the CINC to control the JTF's deployment/redeployment flow. JOPES has the capability to access the Global Command and Control System (GCCS) and reflects near real-time deployment flow information (Joint Pub 5-03.1: 1993). JOPES is the integrated, joint, conventional command and control system used by

the Joint Planning and Execution Community (JPEC) to conduct joint planning, execution, and monitoring activities (Joint Pub 5-03.1: 1993).

JOPES consists of five basic planning functions: threat identification and assessment, strategy determination, course of action development, detailed planning, and implementation (Joint Pub 5-03.1: 1993). Military planners identify the requirements for forces and resources to accomplish the mission and compare them to actual forces and resources available. The JOPES Core database links a number of separate applications to create the JOPES system. The logistics community is involved with the GTN interface. This interface allows for the continued supply of transportation command and control information to the Joint Deployment community by providing an interface to the GCCS Scheduling and Movements (S&M) Core Database on the GCCS platform (Joint Pub 5-03.1: 1993). This interface provides a method of moving data from a non-JOPES system to the JOPES environment.

CINCs, JTF commanders, senior-level decision-makers and their staffs at the National Command Authority level, and the remaining members of JPEC all use and benefit from the JOPES system. During peacetime, JOPES is used to produce OPLANs, contingency plans, and concept summaries involved in the deliberate planning process (Joint Pub 5-03.1: 1993). In crises, JOPES is used for CAP to produce operation orders. During the CAP process combatant commanders use JOPES to determine the best course of action. JOPES has been used for over twenty years to develop the TPFDD and has become an integral part of GCCS (Joint Pub 5-03.1: 1993).

United States Transportation Command (USTRANSCOM) Global Transportation Network (GTN) gives its customers located anywhere in the world a seamless, near-real-

time capability to access and employ transportation and deployment information (Joint Pub 4-01.1: 1996). GTN is an automated command and control information system that supports the family of transportation users and providers, both DoD and commercial, by providing an integrated system of in-transit visibility information and command and control capabilities (Joint Pub 4-01.1: 1996). GTN collects and integrates transportation information from selected transportation systems.

Command centers consisting of planners, operators, and logisticians use GTN in peacetime and wartime operations. Most importantly USTRANSCOM uses GTN as a business operations tool that allows the commander to exercise authority and direction over assigned forces (Joint Pub 4-01.1: 1996). There are several different inputs to the GTN network. They include: GO81/Broker Aircraft Maintenance System, Joint Air Logistics Information System (JALIS), Air Mobility Command Deployment Analysis System (ADANS), Asset Management System (AMS), Groups Operational Passenger (GOPAX) System, Consolidated Aerial Port System II (CAPS-II), Global Air Transportation Execution System (GATES), Worldwide Port System (WPS), Integrated Booking System (IBS), Continental United States Freight Management (CFM), Defense Transportation Tracking System (DTTS), Transportation Coordinator Automated Command and Control Information System (TCACCIS), Cargo Movement Operations System (CMOS), Transportation Coordinator's-Automated Information for Movements System II (TCAIMS II), and Defense Automated Addressing System (DAAS) (Joint Pub 4-01.1: 1996).

The Air Force's Logistics Module (LOGMOD) provides major commands (MAJCOMs), base-level logistics planners, and base-level unit deployment managers

(UDMs) with the capability for mobility, reception planning and execution to support worldwide deployment of forces (AFI 10-403: 1998). It provides a responsive, user-friendly system for mobility planning in an on-line format. LOGMOD is a subsystem of the Contingency Operation/Mobility Planning and Execution System (COMPES) (AFI 10-403: 1998). LOGMOD is crucial for logistics planners and unit deployment managers to plan for worldwide deployment of personnel, supplies, and equipment to meet various exercises, real-world contingencies, and wartime tasking. Its standard input, editing, and storage capabilities produce the materiel lists, packing and load lists, and the manpower interface products for Unit Type Code (UTC) packages formatted for base mobility plans (AFI 10-403: 1998). LOGMOD helps maintain combat units and their materiel support in constant deployment readiness.

LOGMOD is built around four major components: Logistics Force Packaging (LOGFOR), Logistics Planning Module (LOGPLAN), Deployment Schedule of Events (DSOE), and Unit Deployment Management (UDM) (AFI 10-403: 1998). LOGFOR is an unclassified global module that contains information on deployment packages. LOGFOR contains data describing the capability of a particular mobility package (AFI 10-403: 1998). It does not link information about a particular mobility package to a particular unit, nor does it contain any classified planning information contained in the JCS operational plans.

LOGPLAN is an unclassified module that assists with mobility and reception planning (AFI 10-403: 1998). Although the linkage of OPLAN information to a particular unit (such as certain Time Phased Force Deployment Data (TPFDD) is classified, the module is able to remain unclassified by using *pseudo* identifications that

do not reveal classified information (AFI 10-403: 1998). The DSOE module is an unclassified output from LOGPLAN. DSOE provides the wing-level user the capability of scheduling and monitoring deployment actions in support of the planned objective (AFI 10-403: 1998).

The UDM is an unclassified module that assists the Unit Deployment Manager with tracking personnel and equipment deployment information (AFI 10-403: 1998). It provides the Unit Deployment Manager the capability to input, update and process reports on deployment training, shots, line numbers, and all other necessary deployment information.

LOGMOD interfaces with other external systems. Interfaces are accomplished via direct electronic data transfer, diskette, Non-secure Internet Protocol Router Network (NIPRNET), hard copy documentation, and other data transmission means (AFI 10-403: 1998). There are no classified automated data transfers required or permitted in LOGMOD. LOGMOD is an integral part of the GCCS.

The Global Command and Control System (GCCS) is an automated information system designed to support deliberate and crisis planning. GCCS is composed of several mission applications built to a single common operating environment networked to support sharing, displaying, and passing of information and databases (Joint Pub 6-0: 1995). The GCCS infrastructure supports a communications capability providing data transfer facilities among workstations and servers (Joint Pub 6-0: 1995). The Secret Internet Protocol Router Network (SIPRNET) provides connectivity between GCCS sites. The SIPRNET is the secret layer of the Defense Information Systems Network (DISN).

War fighting CINCs use GCCS as a planning system at the joint level to acquire information regarding the status of forces and resources. It also has inputs for intelligence data about enemy forces. CINCs also use GCCS to distribute their guidance and decisions, such as Air Tasking Orders (ATOs) (Joint Pub 6-0: 1995).

Another software tool designed to aid the war planner in the decision making process is the Joint Planning Execution Toolkit (JPET). The Joint Planning Execution Toolkit is a distributed, collaborative planning software application tool that uses the common operating environment of the GCCS (JTO: 1998). One of JPET's decision tools is the Course of Action Selection Tool (COAST). COAST provides the war planner with viable COA alternatives based on available forces and grounded in joint doctrine principles. Not being a Windows based program is one of JPET's main disadvantage. Tools can also be classified as repositories of knowledge that an organization possesses. The concept of the use of knowledge as a tool will be explained in later sections. The architecture that ALP is developing seeks to leverage information tools to supply knowledge to the decision makers.

ALP History

DARPA's objectives for ALP are summed up in four main categories. These objectives are automated logistics plan generation, real-time situation assessment, end-to-end movement control, and rapid supply (Carrico: 1999).

Automated logistics plan generation is the capability to automatically generate logistics plans from notional to refined levels of item description and synchronize

operations and logistics actions (Carrico: 1999). The goal is to tightly link the J3 and J4 planning and execution processes and to produce a “Level-5” TPFDD in one hour.

Real-time situation assessment is the capability for logisticians at all echelons to rapidly assess the logistics situation by converting logistics data into information-rich visualizations to understand the current situation and project future states (Carrico: 1999). The goal of this objective is to identify plan deviations within 15 minutes and update a plan within 10 minutes of the deviation, through the creation and use of plan sentinels.

End-to-end movement control provides the capability to maintain end-to-end control of the transportation/logistics pipeline through the automated development of responsive transportation plans, schedules, and continuous monitoring techniques (Carrico: 1999). Its goal is to realize minimal staging and globally optimize air and sealift resources.

Rapid supply is the capability to maintain interoperable connectivity and access between the DoD and commercial vendors, suppliers, and manufacturers (Carrico: 1999). This objective will increase materiel readiness and decrease cycle times associated with satisfying materiel requirements while reducing DoD inventory and overhead costs. The end result is to provide the capability to accomplish continuous demand assessments and sourcing against DoD and commercial inventories (Carrico: 1999).

ALP is a multi-phase program which will culminate in the demonstration of a complete, end-to-end, factory to foxhole, multi-echelon, prototype system across the functional areas of *course of action Development*, sustainment, transportation, and rapid

supply for continuous planning, execution monitoring and rapid replanning of a major force deployment from the continental United States to in-theater final destination (Carrico: 1999). One way to leverage ALP into the war planning process is by capturing knowledge assets of the current process.

Knowledge Management

To understand knowledge management one must first understand the evolution of knowledge. Data is the foundation of knowledge, however it is meaningless unless it can be interpreted and transformed into information. Once data is transformed into information, then it can be put into use. When information is put into use, it creates a level of knowledge. The following definitions expound upon this progression of knowledge (Cho, Jerrell, Landay: 2000).

Data: a set of discrete, objective facts commonly seen in the structured records of transactions. Data is unorganized but consists of independent numbers, words, sounds, or images that can be easily be structured on machines, Data by itself, provides no judgment or interpretation of events.

Information: when data becomes organized, patterned, grouped, and or categorized; thus increasing depth of meaning to the receiver.

Knowledge: richer and more meaningful information put into productive use, e.g. best practices. Knowledge is derived from information.

Explicit or Implicit knowledge: knowledge that is easily communicated between people in the form of hard data, formulas, and written or universal procedures. Examples would include: books, papers, policy manuals, and lessons learned.

Tacit Knowledge: found in the heads of employees and experiences of customers. Contains insights, intuitions, and hunches. Tacit knowledge is highly personal, hard to formalize, and deeply rooted in a person's actions and experiences as well as their ideals, values and emotions.

Knowledge management takes place once knowledge is put into use. Knowledge put into use produces value and this value can be termed intellectual capital. “Converting that knowledge into something that has value is what we have come to know as intellectual capital” (Lynn: 2000). Figure 8 illustrates this hierarchy of knowledge:

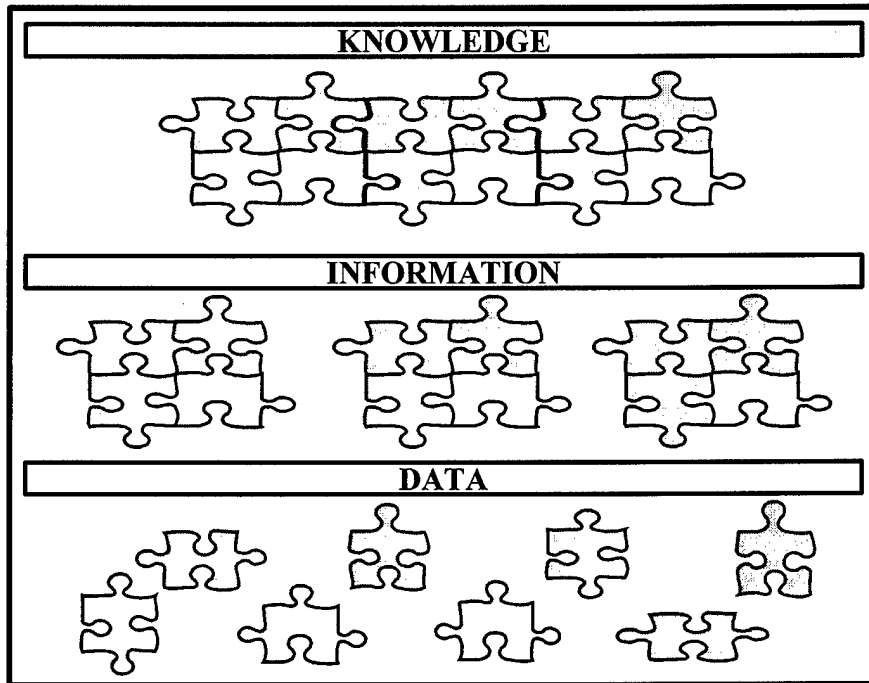

Figure 8: Knowledge Hierarchy

Information technology capitalizes on providing organizations with the information they require to satisfy their needs. While information technology is one way for people to capture information, to gain knowledge they need to attain understanding. Information alone is of little value to a decision maker. Information combined with objective reasoning and judgment gained from experience produces sound decisions. This combination and transformation of information to applied knowledge creates value or intellectual capital (Edvinsson and Malone: 1997). Information remains somewhat

constant, it is the processes used to support information requirements that change rapidly.

Fully understanding information processes is a way to leverage the value of knowledge.

The following story reveals how the Cro-Magnons leveraged the value of knowledge,

(Edvinsson and Malone: 1997):

Intellectual capital, of course, has always been a decisive factor in the rise of civilizations, organizations, and people. For at least 60,000 years our ancestors, the Cro-Magnons, lived side by side with the Neanderthals. Then, about 30,000 years ago, the Neanderthals disappeared.

Why did one species survive and the other parish? Both used tools and language, but the Cro-Magnons had a lunar calendar. Soon they correlated the passing days with the migratory patterns of bison, elk, and red deer. This insight was dutifully recorded on cave-wall paintings and in sets of 28 notches on reindeer antlers.

Hungry for meat, the Cro-Magnon was taught that all he had to do was wait at a river crossing on certain days, spear in hand. In the meantime, the Neanderthals appear to have unwisely scattered their men and their scarce resources poorly. They perished. Intellectual capital made a difference.

This story displays the importance of leveraging knowledge for survival. Just as a commercial organization leverages the value of knowledge to gain a competitive edge over their competitors, the military leverages the value of knowledge to maintain the competitive edge over enemy forces. Profit is the motivation for the commercial organization compared to national security as the motivation for the military.

Identifying Knowledge

The war planning process can be broken down into several areas of knowledge. It is the specific knowledge held by each member of the war planning community that distinguishes them from one another. The application of this knowledge is what creates

value. By identifying the knowledge assets within the war planning process, value can be assigned to the specific components of intellectual capital. To sell the value that ALP can bring to the war planner, the next step must be to identify the knowledge assets within the war planning process. Quinn suggests that professional intellect in an organization operates on four levels (Quinn: 1998):

Cognitive Knowledge (or know-what) is the basic mastery of a discipline that professionals achieve through extensive training and certification. This knowledge is essential, but usually far from sufficient.

Advanced skills (know-how) translate “book learning” into effective execution. The ability to apply rules of a discipline to complex real-world problems is the most widespread value-creating professional skill level

System understanding (know-why) is deep knowledge of the web of cause and effect relationships underlying a discipline. It permits professionals to solve beyond the execution of tasks to solve larger and more complex problems – and to create extraordinary value. Professionals with know-why can anticipate subtle interactions and unintended consequences. The ultimate expression is highly trained intuition – for example, the insight of a seasoned research director who knows instinctively which projects to fund and exactly when to do so.

Self-motivated creativity (care-why) consists of will, motivation, and adaptability for success. Without self-motivated creativity, intellectual leaders can lose their knowledge advantage through complacency.

The first step in managing organizations knowledge is through identification and categorization. Once the organizations knowledge has been identified and categorized, then knowledge management can begin. The war planning process is an iterative process that involves several different people supporting multiple planning horizons. The war planner possesses knowledge from doctrine, formal training, and past experiences. Functional knowledge from several other disciplines mix into the war planning process.

The ALP architecture enables the accesses of these areas of functional knowledge on a real-time basis.

Knowledge Analysis Methods

War planners possess a vast amount of tacit knowledge that is difficult to harness. It is important in the war planning environment to bridge the gap between strategic plans to tactical plans by the transfer of tacit knowledge. The knowledge audit is one method that helps capture tacit knowledge. Liebowitz asserts that the knowledge audit plays a key role in the knowledge management strategy for an organization (Liebowitz: 1999).

One of the critical first steps in the knowledge management area is to conduct a knowledge audit. Some people view the knowledge audit as being the business needs assessment, cultural assessment, and an examination of what knowledge is needed, available, missing, applied, and contained. In the same manner that a manufacturing company will first inventory its intellectual capital assets, an aspiring “knowledge organization” should also inventory its intellectual capital assets.

Organizations can assign internal systems, information systems, networks, and culture as valuable assets that appreciate with time. The challenge is to properly manage this intellectual capital that creates value for the organization. One example of creating value is the transformation of human skill or expertise into structural assets. This transformation is one of the objectives of the ALP architecture. The knowledge audit can serve as this inventory to help identify the knowledge assets of an organization.

Karl Wiig defines a knowledge audit as a survey and characterization of the status of knowledge in an organization (Wiig: 1995). Wiig offers various methods for auditing, surveying, eliciting, and analyzing knowledge in his book, *Knowledge Management*

Methods, Practical Approaches to Managing Knowledge. Table 1 provides characteristics of each method considered for this research. The characteristics included in the table include:

- what the method is used for
- which further work it may support
- what it provides
- what the analysis is based upon
- which other analysis methods it may rely upon
- whether it can be considered a detail or overview method

Table 1: Overview of Selected Hands-On Methods

Knowledge Analysis Methods	Selected Features
Questionnaire-Based Knowledge Surveys	<ul style="list-style-type: none"> •Used to obtain broad overview of an operation’s knowledge status –a “knowledge audit.” •May support further KM work in almost any are •Provides responses from many areas and viewpoints categorized as finely as the initial questionnaire specifies •Analysis is based on completed responses •May also rely upon interviews to determine key areas of interest for questionnaire •Broad overview method
Knowledge Mapping (KMap)	<ul style="list-style-type: none"> •Used to develop concept maps as hierarchies or nets •May support KS&P, BKA, etc. •Provides highly developed procedure to elicit and document concept maps from KWs, particularly experts and masters •Analysis is based on interactive work session/interviews & self-elicitation •Broad knowledge acquisition methodology
Task Environment Analysis (TEA)	<ul style="list-style-type: none"> •Used to understand, often in great detail, which knowledge is present and the role it plays in the TBP. •May support preparing for other knowledge analyses and KBS developments •Explores and describes activities, tasks, artifacts, and culture including multi-dimensional relationships between these within the TBP and adjacent business processes. •Analysis is based upon observation, interviews, simulation •May rely or precede VPA, BKA, KMap, and CFKA. •Knowledge acquisition and overview methodology
KADS-Object Analysis (KOA)	<ul style="list-style-type: none"> •Used to obtain overview of an enterprise’s intelligent decision-making functions & knowledge required •May support gaining understanding of the enterprise’s reliance on knowledge and which knowledge is used for particular business purposes •Characterizes & describes broad decision-making functions of the enterprise with focus on the TBP and its functions as intelligent objects. Also characterizes the knowledge involved in broad terms. •Analysis is based on interviews & interactive work sessions •May rely upon TEA, BKA, and surveys •Knowledge overview and acquisition methodology
Verbal Protocol Analysis (VPA)	<ul style="list-style-type: none"> •Used to identify knowledge elements, fragments, & atoms •May support applications other knowledge analyses or development of KBS •Provides knowledge details such as production rules, concepts, perspectives, analyses, decisions, judgments, and methodologies used to perform K-I tasks. •Analysis is based on verbal protocols produced while workers undertake complex tasks •May rely on TEA •Detailed knowledge acquisition methodology.

Imported abbreviations in this table: TBP -- Target Business Process; KBS -- Knowledge Based System; BPR -- Business Process Redesign; KW -- Knowledge Worker; K-I – Knowledge-Intensive

Table 1 displays only a portion of the methods that Wiig mentions. He also reveals that other methods such as the Delphi technique for surveys can also be used for knowledge analysis. The comparison of the techniques listed above and the others brought up in Wiig’s book provided a basis for selecting the knowledge audit method. The knowledge audit gives a broad overview of the extent, nature and structure of an

organization. The knowledge audit strongly complements the knowledge mapping methodology by identifying relevant knowledge repositories that provide hard data to strategic plans for knowledge processing (Liebowitz: 1999).

Knowledge Mapping

Knowledge mapping is used to help discover the location, ownership, value and use of knowledge assets, to learn the roles and expertise of people, to identify constraints to the flow of knowledge, and to highlight opportunities to leverage existing knowledge (Grey: 1999). The principles of knowledge mapping are to understand that knowledge is transient, to sanction, establish boundaries, recognize and locate all forms of knowledge in processes, relationships, policies, and people.

A knowledge map is a visual aid to help navigate explicit information and tacit knowledge, showing the importance and relationships between knowledge stores and dynamics. The outcome of the knowledge map portrays the sources, flows, constraints and sinks (bottlenecks or losses) of knowledge within an organization. After this map is constructed, it can be used as a tool for extended knowledge management. Management could use this tool to see how it compares and aligns with its strategic goals, core competencies, and process knowledge.

Summary

War planners operate in a dynamic environment with great responsibility on every decision they make. Knowledge management is a methodology that can help enhance the war planning process. In order to take advantage of these knowledge management

methods and tools a foundation must first be built. Capturing the knowledge assets of the campaign planning process will be the foundation for this research. A method of inventorying these assets is required after it is captured. One method for identifying this knowledge is through the use of a knowledge audit. Following the identification and inventory, further analysis can be conducted.

The next step will be to map the inventoried knowledge to form a template to more detailed components. For instance, the construction of ALP as an expert system could protect and make more accessible this identified specific knowledge. Access to ALP, as an expert system, can be from a point and click operation on the map. This knowledge held by the war planner represents knowledge as an asset.

Once the knowledge assets of the war planning process have been mapped, then comparison analyses for knowledge management activities can take place. This knowledge map can be maintained and used as tool to incorporate other detailed knowledge in specific areas. The visibility of knowledge in a manageable arena can become the focus of a growing and more detailed understanding of knowledge in the war planning process. Managing knowledge requires people to be aware of critical processes supporting key functions capable of achieving organizational success. It is the theory of this researcher that the most appropriate method for capturing the knowledge in the war planning process must be one that identifies how the knowledge war planner contributes to the accomplishment of developing an optimal operational plan.

III. Methodology

Introduction

An inductive theory-based research approach was used in this thesis. Inductive research develops general principles or relationships that might explain specific observations, anecdotes, or research results (Dooley: 1995). This approach moves from the particular to the general and concludes with the development of theory.

This chapter describes the methodology used in analyzing the CAP process. In order to identify the unique knowledge assets of the CAP process this research was divided into three phases; identification of knowledge categories, knowledge audit, and comparative analysis. This research methodology was structured to recognize the hidden or intangible information assets in the crisis action planning process. Once these assets are identified, their value can be compared. Each of these phases will now be discussed in greater detail.

Identification of Knowledge Categories

The identification of knowledge categories in the crisis action planning process involved two methods, a literature review and face-to-face interviews. The literature review provided the foundation and principles that guide the war planning process. Specifically, the CAP process was broken down into six phases as discussed in chapter two. Interviews were conducted with SMEs to obtain general process knowledge used to help develop the general interview questionnaire (Liebowitz: 2000). The questionnaire developed for the face-to-face interviews can be found in Appendix B.

The literature review assisted in capturing a foundation of knowledge that most war planners acquire through formal and informal training. Doctrine that embodies the cultural mindset and beliefs of the people in the organization facilitates the communication process of sharing information and knowledge to make decisions that achieve desired results. This fundamental knowledge was used to help structure the initial questions used on the first round of interviews. The goal of the first round interviews was to capture the general development of the war planning process. Several open-ended questions were used to capture as much knowledge as possible.

Interview Participants. Once the literature review was complete, the next step was to identify the participants for face-to-face interviews. The intent of the face-to-face interviews was to identify knowledge categories and to set the framework for the questionnaire to be used in phase two of the research. The philosophy for the face-to-face interviews was to gather as much information as possible with the understanding that specific areas of this research would not be addressed until the second phase questionnaire was administered.

The sample size for the first phase of the research consisted of 25 active duty war planners from 10 different units and commands. This sample was chosen to represent war planners from the Air Force Headquarters (Checkmate, and War Plans and Mobility), Numbered Air Forces (9th AF, 12th AF), Major Commands (ACC, AFSOC), the Air Expeditionary Force Center, Air Warfare Center, Command and Control Test and Innovation Group (C2TIG), and the College of Aerospace Doctrine Research, and Education (CADRE) schoolhouse.

The exact demographics of the SMEs were not as much a concern as the war planning experience level that they maintained. The ranks of the interview participants ranged from colonels to majors and included civilian employees. Since the aim of this research was to capture the operational planner's perspective, a majority of the interview participants had operational experience. However, logisticians were interviewed during this phase to capture both perspectives of the planning process.

Interview Analysis. The open-ended questions used in the interviews and the literature review of the written policies and doctrine served as a foundation for the questionnaire used in the second phase of this research. These questions are listed in Appendix A. Based on the results from the interviews, the author chose to focus on the crisis action planning process at the Unified Command level.

The overwhelming response from the Numbered Air Force and MAJCOM interviews was that by the time an operational order was sent to them most of the operational and logistical plans have already been established. This finding indicated that further operational and logistical planning would not be required, and that the initial assumptions and general strategy were based on the previous plans. To capture the knowledge of the interaction between the operational and logistical planners, the initial planning process of the CAP process was the focus for the knowledge audit in phase two of this research.

Knowledge Audit

The purpose of conducting a knowledge audit is to take an inventory of all the possible knowledge categories in an organization or process. The audit tracks the inputs, outputs, flows, sinks, barriers, and stores (Liebowitz et. al: 2000). Knowledge flow analysis can be used to gain overview of knowledge exchanges, losses, or inputs of the task business processes or the whole enterprise. Once the knowledge audit is conducted, the knowledge mapping process can be used to produce a visual aid for further comparative analysis.

Questionnaire Development. The validation of these knowledge categories was conducted using a knowledge audit questionnaire. As discussed in Chapter 2, the knowledge audit is one of the critical first steps in the knowledge management area and is often viewed as being an examination of what knowledge is possessed, needed, and missing (Liebowitz et. al: 2000). The knowledge audit questionnaire used in this research effort was derived from a knowledge audit described by Liebowitz and others (2000). In this article, the authors describe a knowledge audit questionnaire used in a case study. The questionnaire used in this research had three overarching questions. The first question asked for war planners to list specifically the knowledge they possessed to do their job. The second question asked for war planners to list the missing knowledge they needed to do their job. The final question asked the war planner to list the knowledge they needed to do their job better. A sample of the complete questionnaire used is provided in Appendix B.

Questionnaire Participants. The questionnaire participants were chosen based on the analysis from the first phase face-to-face interviews. Plans from the top-down are made to reflect the objectives and goals of the parent organization. In the case of the military war planning environment, the objectives and goals are directed from the National Command Authorities. The CAP process directly involves the National Command Authorities interaction with the Unified Command planning staffs with the Joint Staff acting as a facilitator. Plans are estimates of what needs to be done and are executed in an environment of uncertainty. Knowledge made available in an accessible and timely manner will assist the planning staffs in producing plans that are more accurate. Risk will always be a factor in the planning process, but the minimization of risk is a priority of all planning processes. The prevention of risks and errors in the planning process can be greatly reduced if addressed early in the planning process. The CAP process was selected for this research with the goals of capturing the war planning process at the earliest stages of the planning process.

The participants in the questionnaire consisted of personnel from the Joint Staff (J3), Air Force Headquarters (Checkmate), Joint Forces Command (JFCOM), Pacific Command (PACOM), and European Command (EUCOM).

Questionnaire Analysis. The method used in this research to analyze the questionnaires was the knowledge audit method. Wiig states that a knowledge audit may identify the following (Wiig: 1993):

- Information glut or lack of information
- Lack of awareness of information elsewhere in the organization
- Inability to keep abreast of relevant information

- Significant “reinventing the wheel”
- Common use of out-of-date information, and
- Not knowing where to go for expertise in a specific area

This research will focus on identifying what knowledge is needed, what knowledge is available and missing, who needs this knowledge, and how this knowledge will be applied. The knowledge audit was conducted in the following steps and adapted from Liebowitz’s et. al. article “*The Knowledge Audit*” (Liebowitz: 2000).

Step one of the audit was to identify what knowledge currently existed in the war planning process of CAP. This was accomplished from phase one of this research to include the literature review and face-to-face interviews. The face-to-face interviews captured both knowledge obtained from the war planner’s experience (tacit knowledge) and formal training (explicit knowledge). The information acquired from this step was used to determine existing and potential sinks, sources, flows, and constraints in the CAP process.

Step two of the audit identified what knowledge was missing in the CAP process. This step of the audit analyzed the information received from the interviews to determine what knowledge the J3 planner needed to exchange with the J4 planner to achieve the desired CAP goals.

The final step of the audit was to categorize the results to provide a foundation for the knowledge maps. These maps identify the taxonomy and knowledge in the CAP process. The knowledge audit strongly complements the knowledge mapping methodology.

Comparative Analysis

Once the results of the knowledge audit were analyzed, a comparative analysis was performed. Knowledge mapping methodology was implemented to provide visual representations of the comparative analysis. A knowledge map can capture and integrate the knowledge collected in a knowledge auditing process. It can also help bridge the gap personal knowledge assets and information technology assets. The comparative analysis used in this research was conducted by the visual representations of knowledge maps.

The knowledge maps display the CAP process as it is written in defense doctrine and perceived by the operational planner (J3). The written guidance, used in this research, can be found in Joint Pub 5-0, 5-00.2, and 5-03.1 and summarized in chapter two. The inputs to this map were supplied from the literature review and the results and analysis of the knowledge audit. This map proves beneficial because it not only tracks the fundamental process flow but also attempts to capture all forms of knowledge possessed, missing, and desired and the relationships and interdependencies between knowledge sources.

The knowledge maps will display the opportunity to leverage the ALP architecture to enhance the CAP process. These maps will be able to display how the gap can be bridged from the current process to “ideal” process. These maps not only hold summary level knowledge and relationships, but also act as a graphical user interface (GUI). The main goal of these maps are to highlight opportunities to leverage existing knowledge through the use of a computing architecture such as ALP.

Summary

Discussion of the methodology provided the reader information on the process used for identifying the knowledge categories that were audited and then compared in this research. The first step of doing a comparative analysis is to clearly define the objects under comparison.

The literature review and initial round of face-to-face interviews accomplished the objective of identifying the knowledge categories to further research. Once these knowledge categories were identified, they were audited or inventoried.

The knowledge audit inventoried each knowledge category and presented a foundation for the comparative analysis. This process plays a key role in the identification of knowledge management strategy within an organization. When the audit identifies both explicit and implicit knowledge of the war planning process, the construction of the knowledge map can be used, as a tool to find the knowledge an organization needs more quickly.

Knowledge mapping, as used in the comparative analysis phase of this research, can serve as a continually evolving process memory, capturing and integrating the key knowledge assets in the war planning process. Just as private industry faces the needs to be more agile, to anticipate threats and opportunities, to react faster, and to be more cost effective, the war planning process faces these hurdles. The main difference is that private industry is motivated financially to gain market advantage and the war planning process is motivated to gain political advantage over the enemy to secure national defense.

IV. Results

Introduction

This section analyzes the results generated from this study. Each part of the CAP process was disaggregated into decision level activities. After these processes were broken down, they were then examined. The current CAP process as described by formal publications was already presented in the literature review. Next, the current CAP process, as defined by SME interviews, was analyzed and will be presented. Current issues that arose during the interview process will be presented and discussed. Finally, the CAP process--with the ALP architecture applied, will be explored. While the body of this chapter will refer only to excerpts from the process maps, a complete listing can be found in Appendices F through I.

What is the Current CAP Process According to SMEs?

The current CAP process was determined by face-to-face interviews and email surveys with subject matter experts (SMEs). The information identified from this process was later inventoried by means of the knowledge audit methodology. After the knowledge audit categorized the different knowledge assets and process knowledge pools, the knowledge mapping foundation was set. The knowledge audit is a static process that captures the thoughts and ideas of the SME at a snapshot in time. Knowledge maps are dynamic in nature and could be applied to a wide variety of scenarios and time spans. The views of each level of the decision making process will be included in each distinct phase of the CAP process.

IDEF Modeling

The Integrated Definition (IDEF) methodology was used to construct the knowledge maps in this research. The IDEF technique was designed to provide a multitude of viewpoints required to describe business processes and software lifecycle processes (Hanrahan: 1995). The Air Force has used the IDEF methodology in several software system development efforts. Figure 9 displays the basic notations and components of the IDEF process.

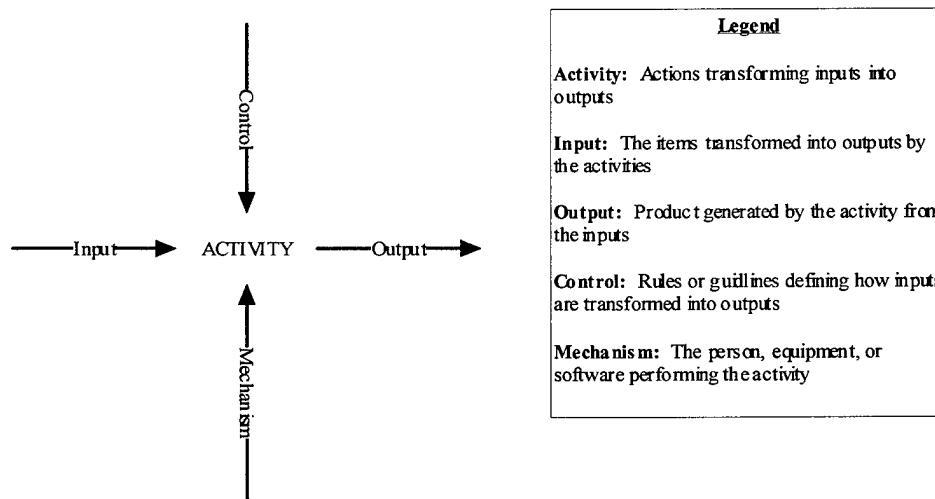

Figure 9: IDEF Model

The basic IDEF model maps activities that transform inputs into outputs while under the influence of controls and mechanisms (Hanrahan: 1995). Controls are standards or policies that guide the process. Mechanisms are the agents (people, tools, or

systems) that carry out the actions of the process. The IDEF technique allows for the decomposition of diagrams from general processes to detailed descriptions of activities. The IDEF process mapping technique will be used for the remainder of this research.

Phase III, COA Development. The initial step of the *COA Development* phase reflects the way it is written in policy. The NCA either decides to take no action, delay decision in light of further information, use non-military action, or progress with the CAP process and utilize military options (Joint Pub 5-00.2: 1999). Two of the five organizations interviewed in this section, Checkmate and JCS, play active roles in communicating with the NCA.

Checkmate is an Air Force organization based in the Pentagon, which operates as a pool of functional war planning experts to assist and advise the JCS on military alternatives. They are not in the formal chain of command nor do they have any authority in the decision making process of CAP. Checkmate plays a significant role in coordinating planning efforts between CINCs and supporting CINCs as required. Depending on the severity of the crisis, Checkmate's role will vary. The more serious the situation, the more involved Checkmate will become in the process as they advise and coordinate with the JCS and the rest of the JPEC.

The JCS's involvement varies upon the scale of the crisis faced by the supported CINC. If the crisis is insignificant, then the involvement in the *COA Development* process could be minimal or even nonexistent. When the JCS is involved with the *COA Development* process, they publish the *warning order* and assist in relaying the guidance from the NCA to the supported CINC (Joint Pub 5-00.2: 1999). The *warning order* tasks

the CINC to prepare the possible COAs and the commander's estimate, which contains the recommended COA. The JCS provides the supported CINC with the service and support they need to achieve their objectives. Their main deliverables are clear objectives, desired effects, exit strategy, and resource availability to the supported CINC. It was noted during the interview process that from time to time civilian leadership dictates national military strategy and creates ambiguous directions and objectives.

When time criticality is the overriding constraint, deviations from the normal process take place. In such a case, the normal *COA Development* cycle is forgone and a specific COA is directed to the CINC from the NCA via the JCS (Joint Pub 5-00.2: 1999). It is interesting to point out that when the NCA directs a specific COA, they must still interact with all of the support agencies and systems that are inputs to the *COA Development* process.

When the *COA Development* is executed at the CINC level, there are normally three or more COAs developed to present to the commander. The goal is to present multiple, feasible COAs that have variety. Variety and feasibility are key factors when considering joint operations consisting of multi-service and multi-nation alternatives. The JPG's deliverable is a commander's estimate that includes the variety of developed COAs along with the recommended COA.

The essential knowledge provided by the J4 to the J3 involves TPFDD feasibility during *COA Development* and analysis. Logistic constraints, such as resource availability, fuel capacities, and munitions availability are other important factors that play a part in the development of a COA. The J4 also acts as a functional liaison with

USTRANSCOM. Figure 10 displays the aggregated SME's perception of the *COA Development* process.

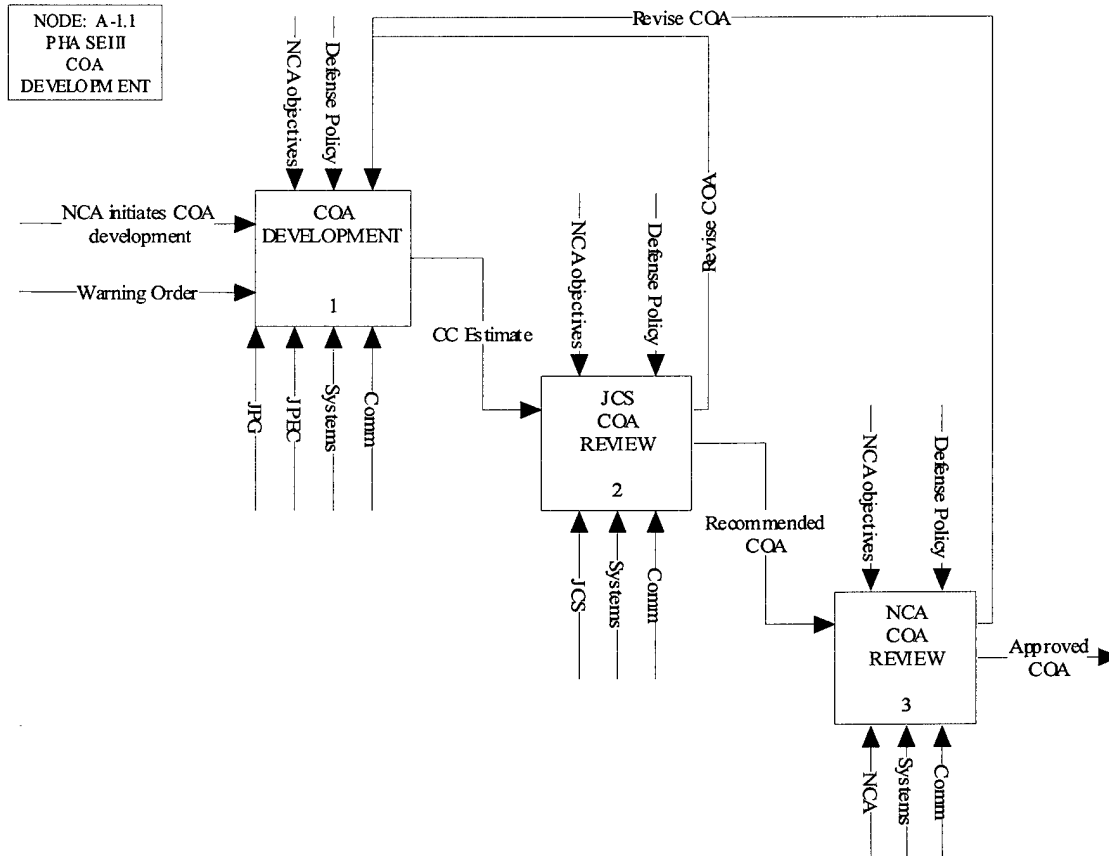

Figure 10: Current Process for Phase III

Responses varied little between interviews concerning the *COA Development* phase of CAP. The five war fighting CINC's each have specific geographical responsibilities that alter their planning processes to accommodate specific needs and objectives for their area of responsibility (AOR). The JCS stated that their underlying factors were time and situation dependency. JCS said they do not normally get involved with providing guidance and assistance to the CINC unless requested. One unique aspect

of the JCS role in the CAP process is their interaction with civilian agencies, especially during humanitarian missions. They supply a link between civilian agencies and the military agencies. Like the JCS, JFCOM's mission encompasses a high percentage of interaction with civilian agencies.

JFCOM's mission has grown in recent years to include domestic crises. When a domestic crisis takes place, JFCOM works hand in hand with non-military crisis action organizations such as Federal Emergency Management Agency (FEMA). Because of their interactions with non-military agencies, a need exists for coordinated communication between the two agencies.

JFCOM also must plan for the lead-time it takes to activate military reserve units that are involved with the course of action under consideration. Another factor that comes into play during the planning process for JFCOM is the activation of the National Guard. If activated, the question remains under whose control they will fall during times of crisis; the states or JFCOM. The *COA Selection* process as described by the SMEs appears to track more closely to the written policy than the *COA Development* process.

Phase IV, COA Selection. After the CINC submits the commander's estimate with the recommended COA, the JCS reviews and evaluates the COA and prepares recommendations for the NCA (Joint Pub 5-00.2: 1999). Once the NCA approves the *COA Selection*, they direct the JCS to issue the alert order. The alert order, approved by the Secretary of Defense and issued to the supported CINC and other members of the JPEC, announces the COA selected and initiates the *Execution Planning* (Joint Pub 5-00.2: 1999).

Time dependency weighs heavily in the *COA Selection* process. The objectives of the COA become more specific if time allows for more coordination between the NCA and the supported CINC. Time and effectiveness are not necessarily directly related. It was noted during the interview at Checkmate that *COA Selection* during the CAP process could be as effective or even more effective than *COA Selection* under the deliberate planning process. Deliberate planning involves modeling, buy-in, and integration within JPEC. This process is aimed to achieve optimal plans but can result in compromise and inefficiencies.

The main consideration in *COA Selection* is how closely does it meet the NCA's objectives and guidance. An analogy was used during the Checkmate interview, comparing the COA process to building a table. Certain tools are required to build a table properly. A carpenter would prepare a toolbox comprised of tools to accomplish the task of building the table. The toolbox would not include unnecessary tools that would have no value in the process. In like manner, the war planner would develop a COA that would match the NCA's objectives and guidance. Likewise, the NCA's selection determination would be based on the same criteria.

The JCS could issue a planning order prior to the NCA selecting a COA. The planning order would have to be approved by the Secretary of Defense once a COA is selected by the NCA. JFCOM proclaimed in their interview that it was very common for the JCS to provide a *heads-up* on pending decisions at the NCA level. Figure 11 shows the collective SME's perception of the *COA Selection* process.

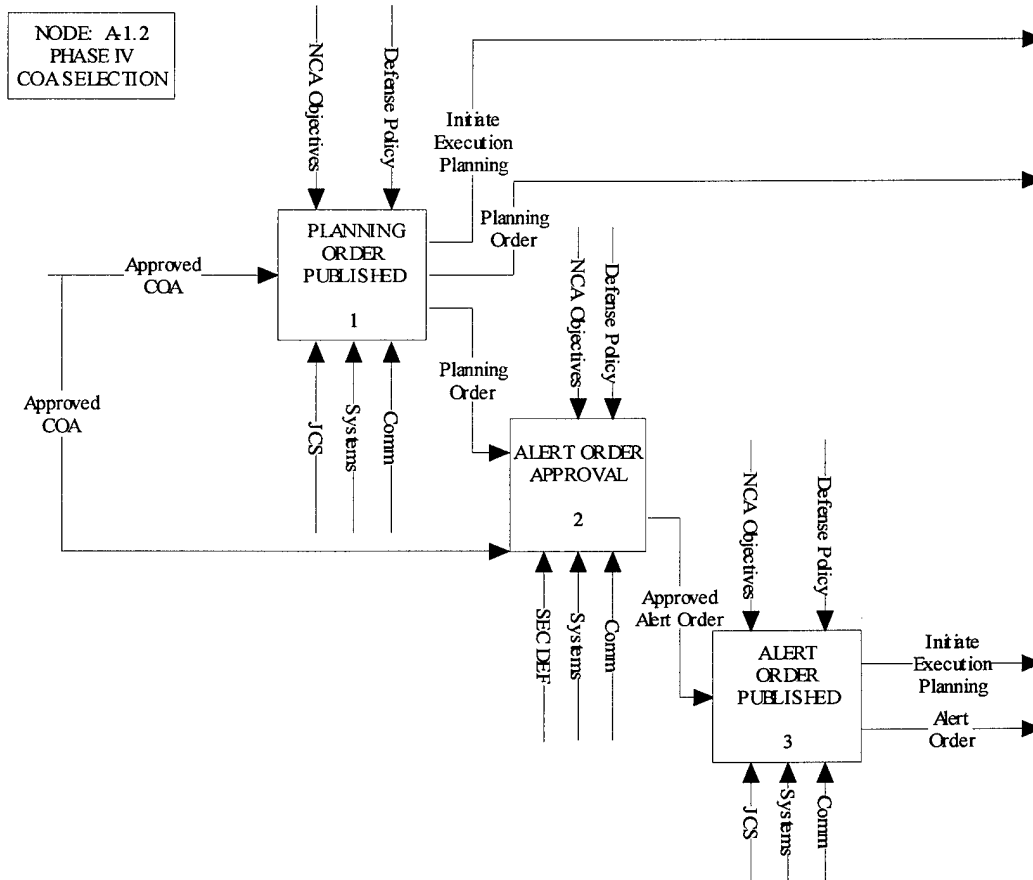

Figure 11: Current Process for Phase IV

Phase V, Execution Planning. The *Execution Planning* phase is initiated when the alert order is issued. The CINC transforms the approved COA into an OPORD. The CINC's OPORD provides further guidance for *Execution Planning*. The CJTF develops an OPORD and TPFDD, using JOPES procedures, based on the supported CINC's OPORD (Joint Pub 5-00.2: 1999). Actual forces, sustainment, and strategic mobility resources are identified and the concept of operations is described in OPORD format (Joint Pub 5-00.2: 1999). The end product of the *Execution Planning* phase is the OPORD.

The J3 and J4 relationship becomes closer as the J4 continually monitors logistics resource availability and location. The identification and availability of aerial ports of debarkation and sea ports of debarkation along with material handling equipment are vital information required for *Execution Planning*. The J4 liaison with USTRANSCOM becomes critical and more detailed at this phase of the planning process.

USTRANSCOM develops transportation schedules. Continuous TPFDD refinement and validation become the primary responsibility of the J4. Any changes to the validated TPFDD must be coordinated through the supported CINC and USCINTRANS. The J3 begins to transition into developing air tasking orders (ATO), matching aircraft to targets, air refueling requirements, and air space control issues. The *Execution Planning* phase ends with the NCA's decision to implement the OPORD. Figure 12 captures the SME's description of the *Execution Planning* process.

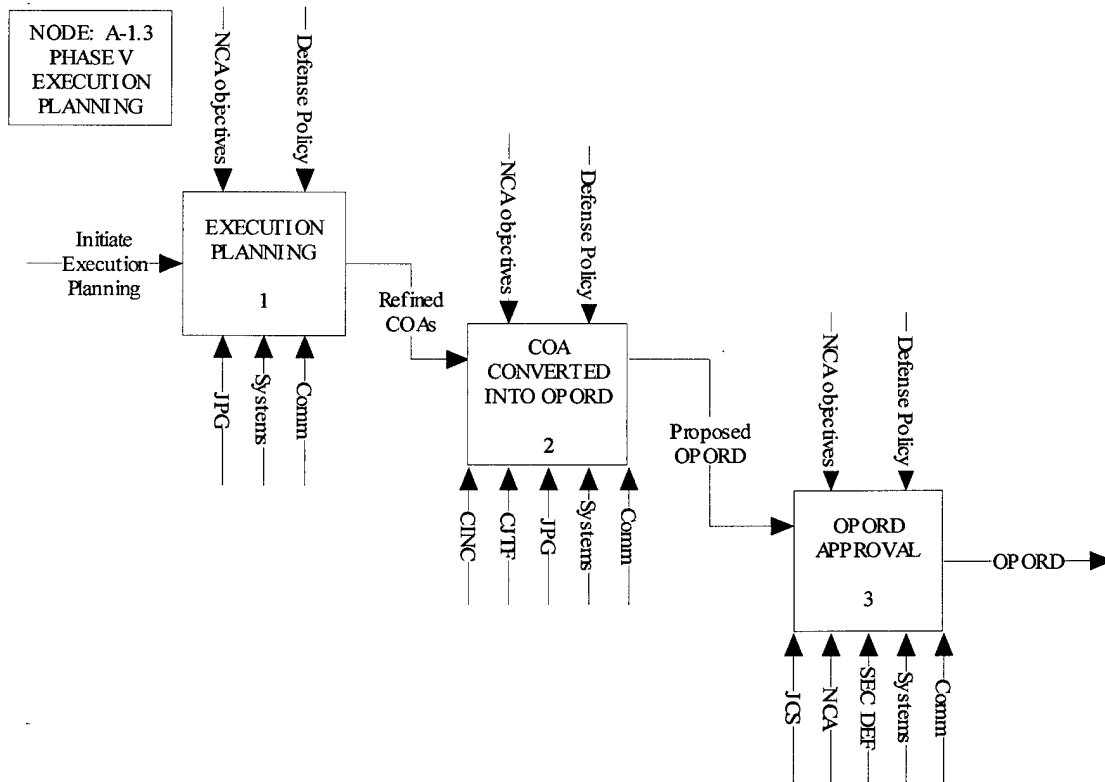

Figure 12: Current Process for Phase V

Other Issues from SME's Responses

The most common response from all of the SMEs concerned the unity of the planning process early in the initial phases of CAP. Not only does a tight, cohesive working relationship need to exist within the JPG but also between the JPG and the rest of JPEC. Of the three phases of CAP researched in this study, *COA Development* was viewed by the SMEs as the most critical time for the J3 and J4 relationship to coexist. It is during this time of *COA Development* the J3 relies on the J4 supplying TPFDD feasibility and airlift information. This was emphasized during one interview when a SME stated that if a vast amount of resources will be required to support a desired COA, most likely airlift would not be sufficient to handle the total capacity of the resources

required. In this case, sea lift must be sought to handle the vast amount of resources. The noted lag time for sea lift was estimated at twenty days from CONUS to an overseas location on average. Thus, the sea lift must be sourced and planned for early in the planning process to ensure the resources will be available when needed to support the CINC's objectives.

The make up of the JPG in the CINC'S in this study varied from one another. JFCOM mentioned that lawyers and medical personnel were especially important parts of the JPG when planning for domestic crisis. PACOM uses a 39 person Deployable Joint Task Force Augmentation Cell (DJTFAC) to help *jump-start* JTFs conducting CAP. DJTFAC members, consisting of O-4's and O-5's from each J code, are specifically trained in CAP and JTF operations. One SME discussed the time spent training their CAP team members. During JTF exercises, the CINC spends one third of their time training members in academic classes and two thirds of their time in CAP (*COA Development*, selection, and war gaming) and OPORD development. Key traits for CAP team members were war planning training, real world experience, and theater knowledge. One SME quoted, "If advanced knowledge of the theater is obtained well in advance, one can research war planning needs within hours."

The SME's noted that many of the tools used in the CAP process were outdated and did not meet their needs. White boards and markers were common links among all of the subjects interviewed. A logistician revealed that during the most critical time of CAP development, TPFDD development, there exists a great need to integrate the GTN and JOPES systems. Most every SME mentioned that the planning cycle must be

reduced to maintain our military superiority and that advanced technology needs to be developed to satisfy this deficiency.

How Does the Current CAP Process Compare to What ALP Can Deliver?

ALP has the capacity to significantly enhance the current CAP process. ALP can deliver a dynamically updated real-time access to information at its source (Carrico: 1999). This access to the CAP process will allow for a distributed collaborative environment enabling rapid decision-making and command and control. This could potentially result in unity of effort, speed of command, and synchronization of forces. The specific areas in which ALP can enhance the current *COA Development* process during TPFDD development can be displayed in Figures 13 and 14.

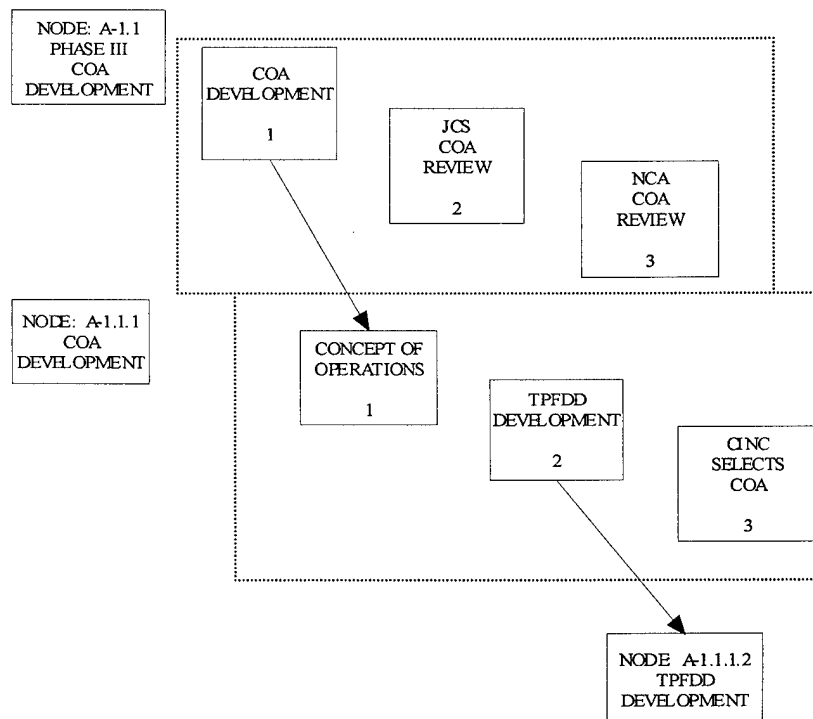

Figure 13: Phase III Overview

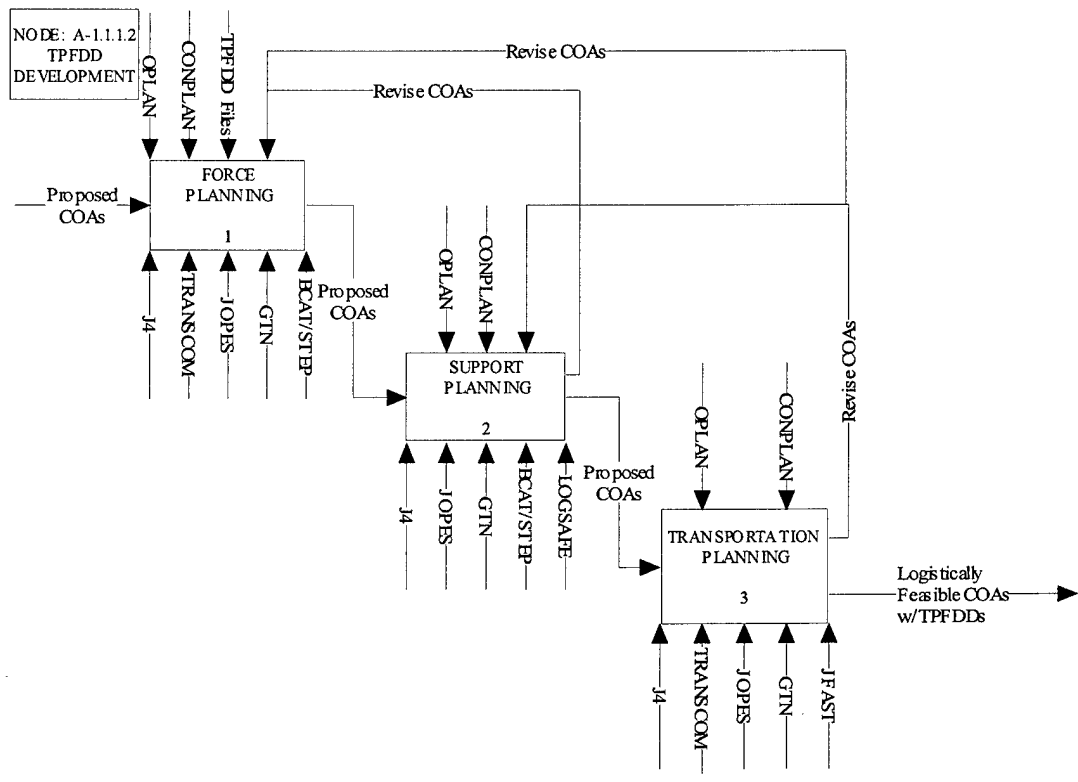

Figure 14: Phase III, TPFDD Development

The three steps involved with TPFDD development (force planning, support planning, and transportation planning as shown in Figure 14) are separate independent processes. Each step must be accomplished prior to the start of the next. During the deliberate planning cycle, this iterative approach is acceptable. However, during the crisis action planning cycle this delays data access and response time. Different information systems are used in each phase of the TPFDD development. The integration of these planning phases is necessary for future war planning efforts. ALP's application as a collaborative planning tool that breaks down operations and logistics missions into identifiable tasks can satisfy this deficiency (Carrico: 1999).

ALP can also profoundly effect the *COA Development* phase through the use of its Mission Resource Value Assessment Tool (M-R VAT). The M-R VAT presents a new way to approach TPFDD development. TPFDD feasibility and validation play a vital role in optimizing the CAP process. TPFDDs are built upon the principle concept of Unit Type Codes (UTCs). UTCs are five-character alphanumeric codes that uniquely identify each type of unit of the Armed Forces (AFI 10-403: 1998). UTCs are the basic building blocks of force deployment packages. Standard UTCs are built for bare base scenarios. Standard UTCs normally undergo a process called *paring and tailoring*.

Paring and tailoring is a process where the UTC is transformed from the standard UTC to a custom UTC that meets the requirements of a deployment. The paring and tailoring process involves time and planning. During the CAP process, time is critical, and TPFDD development must be done expeditiously. ALP's M-R VAT breaks away from this norm and approaches the logistics support capability in an effective and efficient manner. The goal of M-R VAT is to bring what is needed most when it is needed most. The use of ALP's M-R VAT will speed up the TPFDD development and free airlift for other requirements sourced in the *COA Development* phase (Swartz: 1999).

During the *COA Development* phase, ALP will profoundly affect the decision making process at several levels of command and planning horizons. When the crisis first occurs, the NCA and JCS will have access to the appropriate readiness decision support systems to discern the feasibility and availability of resources for particular COAs. This access to such knowledge will allow them to make better and timelier decisions when the time sensitivity of the crisis does not permit the CINC to participate

in the development of the COA. When the CINC is able to develop the COA through the normal process, the speed and continual assessment of the information provided on a real-time basis will allow for more optimal recommendations to the NCA.

ALP's utilities will allow the NCA and JCS to validate the recommended COA, thus decreasing the time it takes to select a COA. Once the COA is selected and the JCS publishes the alert order, ALP will enable a shared access to the vital information held in the alert order for the entire JPEC. Figures 15 displays the planning order publishing process during the *COA Selection* phase.

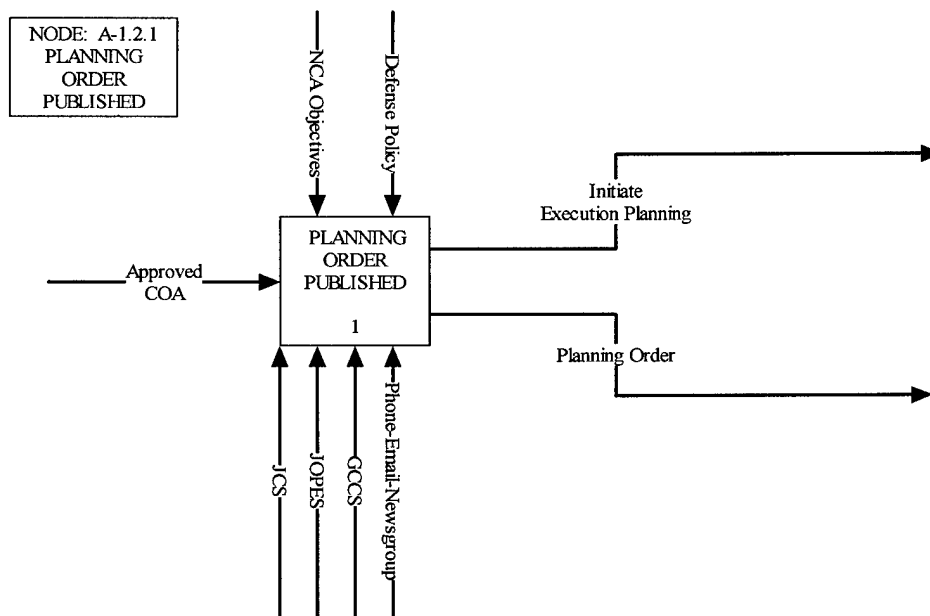

Figure 15: Phase IV, Planning Order Published

Figure 15 applies to all types of orders published during CAP. The JCS currently writes and publishes orders in a matter of hours. However, the process can be delayed if the approving authorities (Secretary of Defense or other delegated civilian politicians) are not available to sign them. The application of ALP as a distributive agent in the order

distribution process could greatly enhance and speed and accuracy of the current process (Carrico: 1999). Widespread distribution of orders would also benefit the planning process, as supporting agencies would also have the information much faster.

During the *Execution Planning* phase, ALP's collaborative nature will allow for optimization of TPFDD and OPOD development at the CJTF level. One of the most significant obstacles in the current CAP process is the dynamics of TPFDD development. The J3 is heavily dependent upon the J4 to constantly stay abreast of TPFDD feasibility and resources. ALP's real-time visibility of resources will allow the JPG to transform the COA into an OPOD in an expedient manner. When the JCS publishes the OPOD once again, the JPEC will instantly have access to the pertinent information. Figures 16 and 17 display a detailed view of the *Execution Planning* phase.

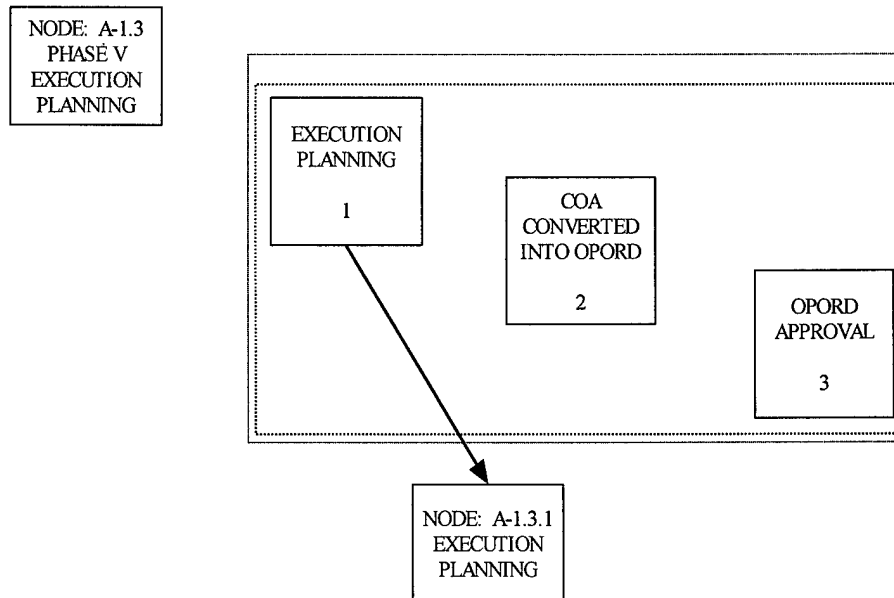

Figure 16: Phase V Overview

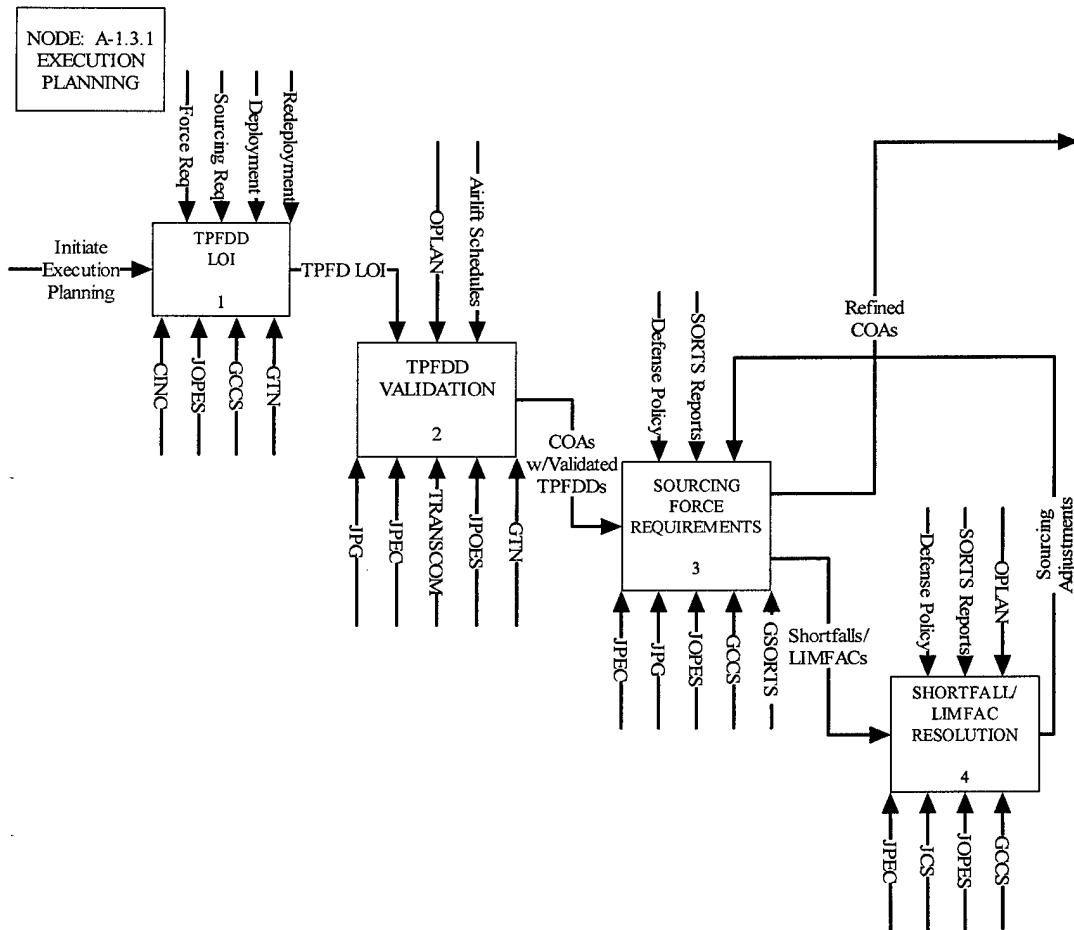

Figure 17: Phase V, Execution Planning

Once again, the application of ALP as a collaborative planning tool could speed up the validation and sourcing phase of *Execution Planning*. This application of ALP serves as a *template* for all other planning support systems. ALP's use as a *template* for planning support systems could not only expedite the current process but may allow for a smooth transition from the planning phases to the execution phase. After the TPFDDs are validated and sourced, shortfalls and limiting factors will instantly be known

throughout the joint operations planning community. This allows for a more optimal solution system wide.

Future Air Campaign Planning

In a paper written by Maris McCrabb, he discussed campaign planning for the future. He emphasized the need for planning and readiness to reduce the uncertainties of war. McCrabb states (McCrabb: 2001):

...these are the capabilities we can exploit over our adversaries, whoever and wherever they maybe. First is our capability to achieve air, sea, and space superiority. Second is our ability to project force anywhere in the world—an ability that Air Force people call “global reach.” Third is our capability to forcibly enter any theater, either through amphibious, airborne, or air assault “global power.” We have this capability because we have technology—particularly stealth and precision—that no one else on earth can match, and we have people with the fortitude to see the task through.

Besides possessing the physical ability to attack our enemies from all levels of strategic, operational, and tactical war, the DoD has the technology to win at *infowar*--information warfare fought in cyberspace. The US military has the advantage to observe better, decide faster, and act quicker than the enemy. This process is also referred to as the OODA (observe, orient, decide, act) loop, coined by John Boyd. Boyd’s assertions stated that one could paralyze an enemy by *operating inside their OODA loop*, meaning that the individual is operating at a faster cycle speed than the enemy (McCrabb: 2001). Time constraints and massive amounts of information slow down and enlarge the OODA loop. This presents a problem during the CAP process. The addition of decision support systems can provide decision makers with loads of information. However, the decision maker does not have the time to decipher that information. Information technology

systems should be built around those processes needs that offer the decision maker the precise information needed to achieve the desired objectives.

ALPs integrative ability to converge several types of decision support systems will enable the decision maker to reduce the OODA loop and attain a distinct advantage over the enemy. ALP will provide the decision maker with the right information at the right time. ALP's M-R VAT is a planning aid that implements quantitative analysis to employ high-speed decision making. ALP not only provides the decision maker with ability to observe and orient at a much faster and effective manner, but through the application and analysis of ALP's M-R VAT the decision maker's decisions and actions can be accomplished more efficiently. The longer the planning cycle or OODA loop takes, the more outdated and unreliable the information becomes. ALP measures to reduce the planning cycle in all four areas of the OODA loop will produce optimal plans.

In an article written by Steve Gordon, a technical director at the Air Force Agency for Modeling and Simulation, he writes about the future of military operations.

Our Armed Forces can no longer prepare for primarily one enemy and a handful of potential conflict scenarios. Numerous data-gathering systems can help our forces maintain information superiority in combat. Yet, there is a downside here too. Information superiority cannot necessarily guarantee knowledge of the right information or assure correct decisions will be made. Information must be sorted, prioritized, analyzed, and presented using improved combat efficiency as the primary focus. Operational commanders need the right decision support tools to help them maintain information dominance, situational awareness, and an accelerated decision cycle (Gordon: 2000).

Gordons description of future military operations can be directly applied to the future of the campaign planning process. Just as his article states, information superiority does not necessarily provide knowledge. The current campaign planning decision support systems

provide an abundance of information; however, this information is not distributed in a collaborative manner to all planning agencies. Multiple steps in the phases of CAP rely on independent decision support systems. Through time and manual effort, this information is turned into knowledge and applied to the decision making process.

It is ALP's goal to leverage this information, and supply knowledge assets to the decision makers at all planning horizons in a real-time setting. "Maintaining an information advantage and building a knowledge advantage over enemy forces will require new automated decision support tools, including some predictive modeling and simulation systems" (Gordon: 2000). As small scale contingencies arise, the need to maintain information superiority over our adversaries becomes more prevalent than ever before. ALP will provide the linkage between the operations and logistics planner during the CAP process to maintain the knowledge advantage over the enemy.

Summary

This chapter first analyzed and displayed the SME responses on their perception of the current CAP process. Differences between policy and the SME's assessments were annotated and expounded upon. ALP was then considered in the current CAP process where it was shown to be able to improve upon the decision making process based on its proposed objectives as stated by literature. Finally, the future of air campaigning was discussed with a focus on what is needed to maintain superiority over the enemy.

V. Conclusion

Introduction

The significance of this research was that it identified the need for improvements to reduce the campaign planning cycle time. The current campaign planning process is limited by the information made available to the decision-makers. Logistical issues are the major constraints in the campaign planning process. The specific focus of this research was aimed at the J3 and J4 relationship during crisis action planning (CAP). This chapter summarizes the conclusions of each phase of the research. The limitations of the methodology used in this research are discussed. Finally, recommendations and future research possibilities are introduced.

Research Phases

The first phase of the research involved a literature review and face-to-face interviews. This phase was used to identify knowledge from written defense policies, and establish a broad overview of the campaign planning process from subject matter experts (SMEs). The literature review outlined the campaign planning process and identified the roles and responsibilities of the members of the planning process. The face-to-face interviews provided a broad overview of the campaign planning process and streamlined the focus of this research. Based on the responses from the open-ended questions asked of the SMEs and ALP's underlying objectives, the focus of this research was directed towards the CAP process. Once the knowledge required for the CAP process was identified, the next phase of the research was conducted.

The second phase of the research sought to inventory the knowledge that exists in the CAP process. This phase was conducted by face-to-face and email interviews with SMEs that were involved with critical planning phases of CAP. These senior level decision-maker experts were selected due to the responses collected in the first phase interviews and literature review. The knowledge audit methodology was used to capture and categorize the knowledge contained and the knowledge needed in the CAP process. The results from this process showed the similarities and contrasts between the CAP process written in policy and the CAP process as experienced and perceived by the SMEs. Once this knowledge was identified, the final phase of this research was conducted.

The final phase of this research compared the written CAP process, the SMEs perception of the CAP process, and the CAP process with the technology of ALP applied. Knowledge mapping was the methodology used to compare the results of Phase II of this research. This methodology displayed visual representations of the activities that exist in the CAP process. Knowledge maps are dynamic tools that capture and integrate the key knowledge assets that continually evolve in processes. The results acquired from this phase of the research addressed the goals of this research.

Conclusions

The primary goal of this research was to analyze the knowledge shared between the operational planner (J3) and logistics planner (J4) that is required to optimally execute the CAP process. The secondary goal was to answer the following research questions:

1. What is the process involved with the operational order (OPORD) generation?
2. What deployment planning, campaign planning, and operational order generation tools are used today?
3. What is the available knowledge in the CAP process?
4. What is the required knowledge in the CAP process?
5. To what extent does the value of ALP contribute to the CAP process, and where do the existing tools fall short?

The results of this research suggest that a tight relationship between the J3 and J4 planners must exist early and remain strong throughout the planning process. The *Course of Action (COA) Development* phase was deemed the most critical phase of CAP for the interaction and collaboration between the J3 and J4. The research demonstrated that there is no single source supporting information system used in the planning process. Due to this fact, much time is spent assessing resource availability and feasibility to support a desired COA. ALP can deliver dynamically updated, real-time access to information at its source in a distributed mode. This type of collaborative access to information during the CAP process allows for unity of effort, speed of command, and synchronization of forces.

The process and tools involved in the OPORD generation were identified in Chapter IV of this research. The process and tools identified in the Phase II interviews with SMEs tracked closely to what was written in policy. Although the process is spelled out quite clearly, the application of the process can become difficult to execute. Communication from several different planning agencies comes into play during the execution of orders and plans. ALP can profoundly affect the dissemination of

information during the generation and execution of OPORDs. This widespread distribution of information will provide timely and accurate transfer of information for decision makers as well as support agencies to act upon. Tools used in the current process are antiquated and do not allow efficient collaboration to exist. The incorporation of ALP's M-R VAT as a decision support tool will significantly speed up the planning process resulting in a greater number of feasible COAs.

The available and required knowledge in the CAP process was determined from the literature review and SME interviews. The results were presented in knowledge maps located in Chapter IV. These knowledge maps provide a dynamic tool that can adapt to process changes over time. The maps help identify the fundamental knowledge flows taking place during each of activity in the process. This tool can help bridge the gap between personal knowledge and information technology assets. The ultimate goal of the maps developed in this study is to highlight opportunities to leverage existing knowledge using ALP's architecture.

The fundamental potential contribution of applying ALP in the campaign planning process is to maintain superiority over enemy forces. ALP's ability to converge several types of decision support systems will expedite the decision making process. Not only will the decision maker have the information quicker, they will have it more efficiently. Providing the decision maker the right information at the right time allows them to decide and act at a faster rate. ALP's architecture should enable a distinct advantage over the enemy's capabilities to plan and execute their operations.

The theory built from this research can be categorized into three distinct areas: systems integration, information distribution, and speed.

I. Systems Integration.

a) Current information systems used in the planning process lack compatibility and integration. Figure 14, in Chapter IV, displayed how the TPFDD development process involves three separate incompatible information systems to assess logistics feasibility of a selected combat force mix selection. This fragmented process delays the response time in the planning process.

b) ALP's collaborative planning tool, OPSLOG, could bridge this existing gap and integrate existing planning information systems into one common operating system.

II. Information Distribution.

a) Information distribution during the CAP process does not meet the needs of the war fighters. Figure 15, in Chapter IV, displayed how orders are published during the CAP. Although there are information systems that distribute information, they are not standardized or user friendly. The subject matter experts interviewed in this research noted that by the time they can access a published order using an information support system, they have already been contacted by phone. A "Windows based" user-friendly information systems is needed to satisfy the war planners needs.

b) ALP's "Windows based" Real Time Information Fusion process could fuse streams of information and distribute that information throughout the war planning environment.

III. Speed.

a) The time sensitivity of crisis action planning demands speed and accuracy. The designed process of deliberate plans to serve as a benchmark for crisis action planning, has failed to meet the unpredictable requirements to resolve modern day crises. The current planning relationship between the J3 and J4 often lacks continuity.

b) ALP's M-R VAT could provide the link between the J3 and J4 planning staffs, which will optimize the crisis action planning process.

Limitations

An inductive approach to research was used in this paper. Inductive research is theory-building research. The purpose of inductive research is to discover the real scope of a problem and determine if future research is required. Inductive research involves both primary research methods (interviews and surveys) and secondary research methods (literature review), both of which were used in this research. The results of inductive research conclude with a theory.

The main limitation to this approach to research remains that the results in themselves are not useful to the researcher. Although this is true, this method of research did provide significant insight into the CAP process. The results also cannot be generalized since they are not representative of the entire population being studied. The tendency of the respondents to answer positively is another possible research limitation.

Recommendations of Future Research

Future research should build on the theory that ALP provides significant contributions to the war planning process. Now that a theory has been built, further research can test the validity of proposed hypotheses. The in-depth process knowledge revealed in the knowledge mapping technique used in this research can provide a tool to test and validate theory. In turn, further testing of theory will offer tangible results to the researcher. The application of current AFIT research to this proposed theory would provide a framework for real world application.

A proposed method to test the theories of this research would be to apply ALP's architecture in a war planning environment during a Joint Expeditionary Force Experiment (or similar wartime simulation exercise) and compare it's functionality to the current systems used in the planning process.

Summary

The result of this research effort created a methodology and theory to be applied and tested by future research efforts. Defense policy and subject expert matter interviews described the generation of the operational order during crisis action planning and the tools used during this process. The knowledge maps constructed in this research identified the available and required knowledge in the crisis action planning process. These knowledge maps can be used as dynamic tools to test theory and adapt to changes in the war planning process over time. Finally, the knowledge maps identified the specific areas where ALP's projected capabilities could satisfy the war planners needs.

Appendix A: Interview Bullet Background Paper

Purpose of this background paper: to provide the respondent with an overview of the topics of discussion to be addressed during the interview.

Purpose of the interview: to obtain knowledge and understanding of the ***process and factors*** considered when selecting certain combat aircraft asset sets for theater deployment.

- USAF now operates under the expeditionary concept
 - Deploy small contingent of aircraft, 36 fighter and 2-6 bomber assets per set
 - May be expected to commence aerospace missions immediately upon arrival
 - Campaign will require several types of aerospace missions, defined in AFM 1-1

- Our purpose is to look ahead *beyond current prepackaged forces*
 - A tailored force for each scenario
 - Bring ***everything*** you need but ***only*** what you need
 - Calculate time-phase requirements; spin up to fight from day zero...no more “closure” of forces

- Please walk through a complete planning process for expeditionary force contingency deployment
 - Realizing there are several layers of planning and decision-making, *your* views at *your* level are of prime importance in this study
 - What is the ***fundamental process*** of selecting aircraft types to support a campaign?
 - In determining the proper aircraft mix to be deployed and in planning for their deployment, what *factors* do *you* look at?

- Focus on identified factors
 - What makes these important?
 - Is there anything that may affect this factor...underlying sub-factors?
 - How do these factors relate to each other and the overall process?

- Conclusion
 - Any other factors that have not been identified that you feel are important, no matter level?
 - Any important topics we did not discuss?
 - Any contacts you know of that I should talk to regarding this research?

- Soon, a second phase of research will begin. Your continued support will be greatly appreciated.
 - The second phase will be quickly-accomplished email questionnaires to identify specific knowledge in the war planning process—your support will be crucial

Appendix B: Interview Questionnaire

Purpose of the interview: to obtain knowledge and understanding of the *process and factors* considered when selecting certain combat aircraft asset sets for theater deployment.

- Given a Crisis Action Planning scenario, the focus of this research will be on Course of Action (COA) Development, *COA Selection*, and *Execution Planning*
- Compare the CAP process to the Deliberate Planning process
- Understanding that COAs can be developed from a Force Module Package, a partial Force Module Package, or from the ground up.
 - This research will look ahead *beyond current prepackaged forces*; a tailored force for each scenario.
 - Bring *everything* you need but *only* what you need.
 - Calculate time-phase requirements; spin up to fight from day zero...no more “closure” of forces.
- Walk through the CAP planning process:
 - What is the Air Campaign Planner’s role in the COA Development?
 - Responsibilities?
 - External Inputs? (How are they used? Who provides them?)
 - Deliverables?
 - Needs/Limitations?
 - J4 Interaction? (What knowledge do you require from the J4?)
 - Assumptions?
 - What is the Air Campaign Planner’s role in the *COA Selection*?
 - Responsibilities?
 - External Inputs? (How are they used? Who provides them?)
 - Deliverables?
 - Needs/Limitations?
 - J4 Interaction? (What knowledge do you require from the J4?)
 - Assumptions?
 - What is the Air Campaign Planner’s role in *Execution Planning*?
 - Responsibilities?
 - External Inputs? (How are they used? Who provides them?)
 - Deliverables?
 - Needs/Limitations?
 - J4 Interaction? (What knowledge do you require from the J4?)
 - Assumptions?

- What is the make-up of the CAP team?
- How does the CAP process compare to the Deliberate Planning process?
- What is the *fundamental process* of selecting aircraft types to support a campaign?
- What “tools” are used in each of these planning phases?
- What are the most frequently asked questions?
- How dependent the CAP team on knowledge and experience?
- What is the percentage of time spent obtaining knowledge for the CAP process?

Appendix C: Checklist for CAP Phase III

Phase III-COA Development

- What precisely must be accomplished in the crisis to strengthen or support the objectives established by the NCA?
- What are the general operations, intelligence, and logistics requirements to support the actions so as to bring about the NCA objectives?
- Do the military objectives identified take into account exploitable enemy vulnerabilities that are critical to the commander, joint task force's (CJTF) responsibilities and intent or are critical to the enemy's intent?
- From the CJTF's perspective, are the military objectives attainable?
- What is the commitment of the adversary to own COA?
- What are the current rules of engagement (ROE) in the area?
- Do they need to be changed because of the current situation?
- Who should recommend changes?
- Is the authorization to use riot control agents required as an alternative to the use of deadly force to save lives?
- Has NCA approval been requested or received?
- Are riot control agents and protective equipment available to friendly forces?
- What forces are readily available and when could they arrive on the scene?
- What reception and operations support facilities are needed and available?
- What types and amounts of logistic support are available from friendly and allied nations?
- Are joint or multinational interoperability considerations involved?
- Is medical support adequate to support planned operations?
- Has direct liaison authorized been established, as applicable, within the operational, intelligence, and logistics nets, with the committed forces, supported and supporting commands (as applicable), and national agencies?
- What medical support is available in the objective area or provided for in the OPLAN or OPORD?
- Are special operations forces (SOF) required (e.g., United States Special Operations Command, theater special operations command, or host nation SOF)?
- What is the unit readiness of the available or allocated forces?
- What are the major constraints before forces can be committed?
- What is the status of geospatial information and services support within the area?
- What are the environmental (meteorological, oceanographic) support capabilities and constraints within the area? Who is coordinating environmental support?
- Will special CJCS-controlled communications assets, such as the joint communications support element, be required?
- Are Army or Air Force PSYOP units, or Navy supporting units, required?
- What is the command relationship of civil affairs (CA) and PSYOP forces?
- Will the use of deception operations enhance mission success for each COA being considered?

- Have subordinate and supporting commands or agencies been tasked to enter JOPES data base requirements for development of deployment estimates by United States Transportation Command (USTRANSCOM)?
- Has Tactical Exploitation of National Capabilities Program support from the supported combatant commander been requested?
- Have plans for the use of space systems (e.g., for reconnaissance, surveillance, warning, navigation, communications, targeting, weather) been integrated into JTF plans?
- What is the status of strategic mobility resources and supporting elements? Are facilities, airports, seaports, and lines of communications capable of supporting the operation?
- What are the logistics factors that affect actions under consideration?
- Is aerial refueling required during deployment and/or employment?
- Will intermediate staging bases be required?
- What is the backup COA?
- What all-source intelligence resources are available? Has the full range of intelligence capabilities been employed to ensure maximum intelligence support to planning efforts by the supported combatant commander? By the NCA? Has CJTF declared emergency reconnaissance and implemented signals intelligence operational tasking authority?
- Has coordination been conducted with United States Space Command (USSPACECOM) to determine whether repositioning or launch of space systems is required for JTF operations?
- Will electronic warfare units, such as radar jammers or communications jammers, be required?
- Which airports and seaports are available to friendly forces?
- Are runway lengths and weight-bearing capacities adequate for the planned forces?
- Are pier capabilities and depth of water sufficient to accommodate sealift?
- Will use agreements need to be coordinated with other nations?
- Have sufficient contracting officers with adequate contracting authority been assigned?
- Has a sufficient amount of local currency been obtained to support the exercise or operation?
- Has local civilian labor support been acquired?
- Have adequate funds been identified to support the COA?
- Have procedures been established to ratify irregular purchases?
- What procedures must be established to protect information exchange between the United States and foreign forces and governments?
- Have standard JTF Special Technical Operations billets been activated and indoctrination conducted on special access programs?

Appendix D: Checklist for CAP Phase IV

Phase IV-COA Selection

- What COA has been selected? Have the pros and cons of each alternative, with regard to enemy options, been fully and objectively assessed (wargamed)?
- What decisions have yet to be made? What changes to ROE are required?

Appendix E: Checklist for CAP Phase V

Phase V-Execution Planning

- Is the mission clear? Is CJTFs intent clear?
- Are the ROE adequate for the JTF mission?
- Will the selected COA accomplish the objectives?
- If it will not, has this been clearly outlined to the supported combatant commander?
- Is the COA consistent with the law of armed conflict?
- Are command relationships clear, unambiguous, and understood by all parties?
- Between supporting and supported commanders?
- For command and control (C2) for SOF?
- For C2 of CA and PSYOP forces?
- Before operations commence, has the theater J-2 established a joint intelligence center (JIC)? Has the JTF J-2 established a joint intelligence support element (JISE)?
- Has a joint search and rescue center been designated or established?
- Has the CJTF elected to designate functional component commanders (e.g., joint force air component commander [JFACC], joint force land component commander, joint force maritime component commander, joint force special operations component commander)?
- Have the authority and responsibilities for functional component commanders been established by CJTF?
- Have the functional component commands' staffs been organized so that component representation reflects the composition of the joint force?
- Are commanders of the other JTF components aware of the functional component commanders' assigned authority and responsibilities?
- Have liaison officers from the other JTF components been assigned to the functional component commanders to facilitate coordinated joint force operations?
- Has an airspace control authority been assigned? (Normally assigned as a JFACC responsibility, if designated.) Is required liaison provided?
- Has an area air defense commander been assigned? (Normally assigned as a JFACC responsibility, if designated.) Is required liaison provided?
- What is the status of communications?
- Have multiple means of communications been provided for?
- Is there frequency deconfliction?
- Are the joint communications-electronics operation instructions adequate?
- Is there a requirement for joint airborne communications assets?
- Have common communications security materials (authenticators, operations codes, and key lists) been identified for all circuits, networks, and users?
- Are there any other special command, control, communications, and computers requirements to include Global Command and Control System capability for JTF components?

- What country clearances are required for overflight, landing, or staging? What are the existing (or needed) agreements for overflight; staging; transit and refueling for combat, cargo, and evacuation aircraft; and basing rights?
- What forces and concept of operations are available if the adversary escalates abruptly?
- Has sufficient coordination with allies been conducted?
- What constraints have been placed on USTRANSCOM's components (e.g., allocation of lift assets)?
- What is the status of space system support coordination?
- If a theater missile threat exists, has a special request for tactical warning support been made to USSPACECOM's J-3 (in accordance with the Joint Service Tactical Exploitation of National Systems Manual)? Additionally, has USSPACECOM been requested to provide support from the Tactical Event Reporting System (TERS), to include equipment required to receive TERS downlink data (e.g., constant source and joint tactical terminal)?
- Has military satellite communications (MILSATCOM) support been coordinated with the Defense Information System Agency MILSATCOM Systems Office?
- Has Defense Satellite Communications System Ground Mobile Facility support been coordinated with the appropriate regional space support center?
- Has USSPACECOM been requested to provide a Joint Space Support Team to support the JTF and to serve as a focal point for the coordination of space systems support?
- Has the enemy situation changed appreciably; if so, what are the effects on the selected COAs?
- Have all necessary actions been taken to provide for self-defense of JTF forces?
- Will the predicted environmental conditions adversely affect the operation? Who will provide environmental updates to decision makers?
- Is logistics and administrative planning adequate?
- Has the OPORD been published?
- Do the component commanders' plans adequately address the coordinated employment, direction, and control of their forces in conformity with the JTF concept of operation?

Appendix F: Knowledge Map Index

A-0: CAP Phases III-V

A-1: Detailed CAP Phases III-V

A-1.1: Phase III COA Development

A-1.1.1: COA Development

A-1.1.1.1: Concept of Operations

A-1.1.1.2: TPFDD Development

A-1.1.2: JCS COA Review

A-1.1.3: NCS COA Review

A-1.2: Phase IV COA Selection

A-1.2.1: Planning Order Published

A-1.2.2: Alert Order Approval

A-1.2.3: Alert Order Published

A-1.3: Phase V Execution Planning

A-1.3.1: Execution Planning

A-1.3.2: COA Converted into OPORD

A-1.3.3: OPORD Approval

Appendix G: Knowledge Maps, CAP Phases III-V

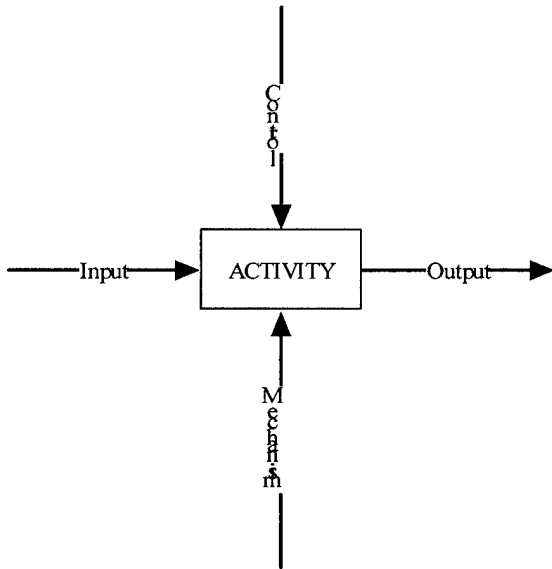

Legend

Activity: Actions transforming inputs into outputs

Input: The items transformed into outputs by the activities

Output: Product generated by the activity from the inputs

Control: Rules or guidelines defining how inputs are transformed into outputs

Mechanism: The person, equipment, or software performing the activity

NODE: A-0
CAP PHASES
III-V

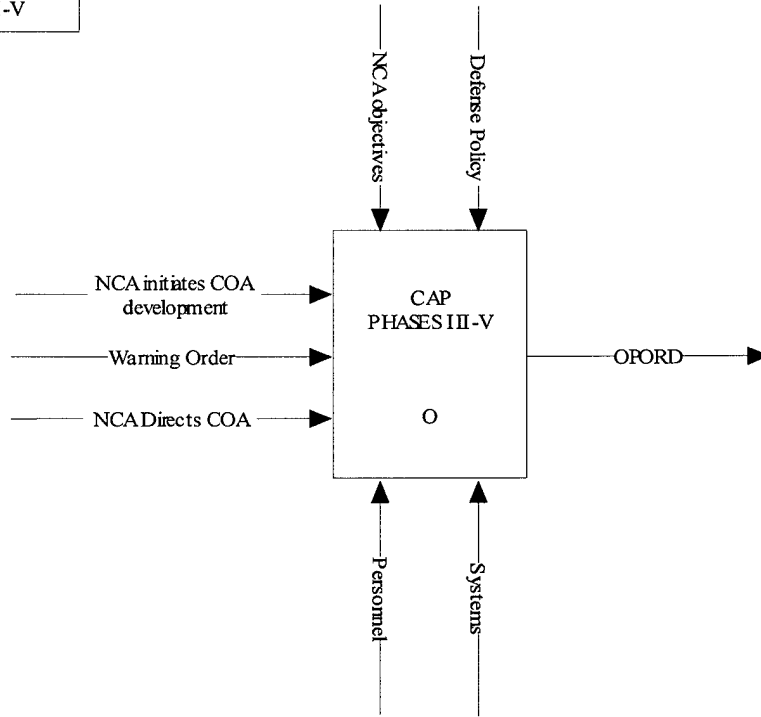

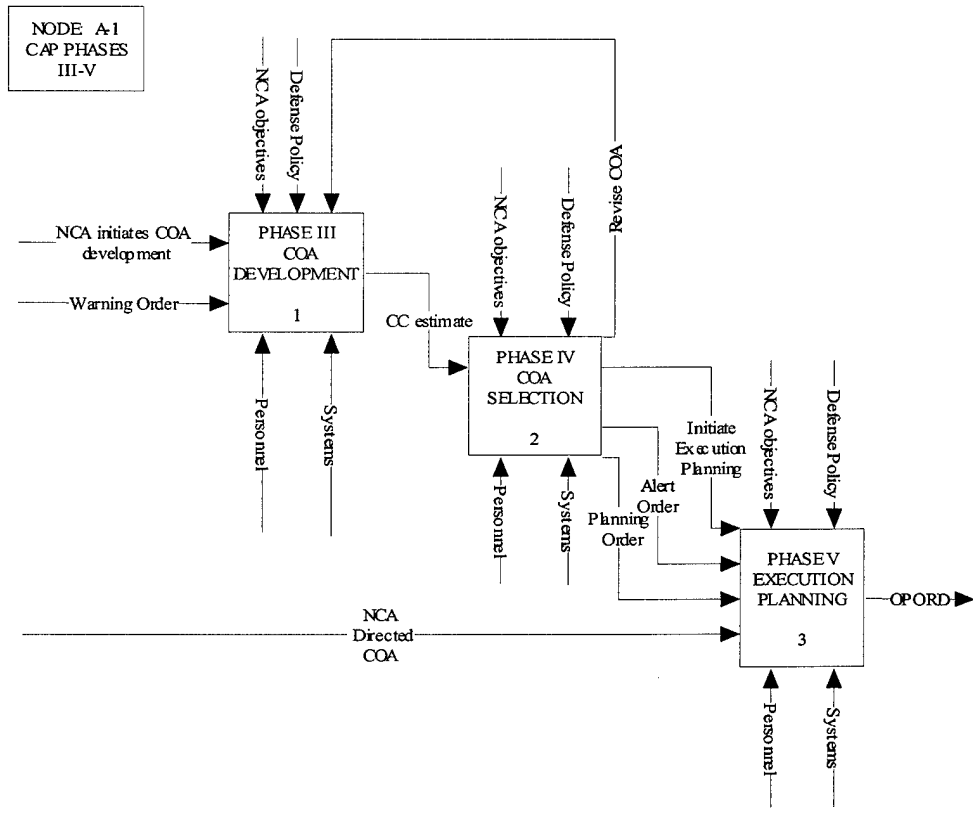

Appendix H: Knowledge Maps, CAP Phase III



NODE: A1.1.1.1
COA
DEVELOPMENT

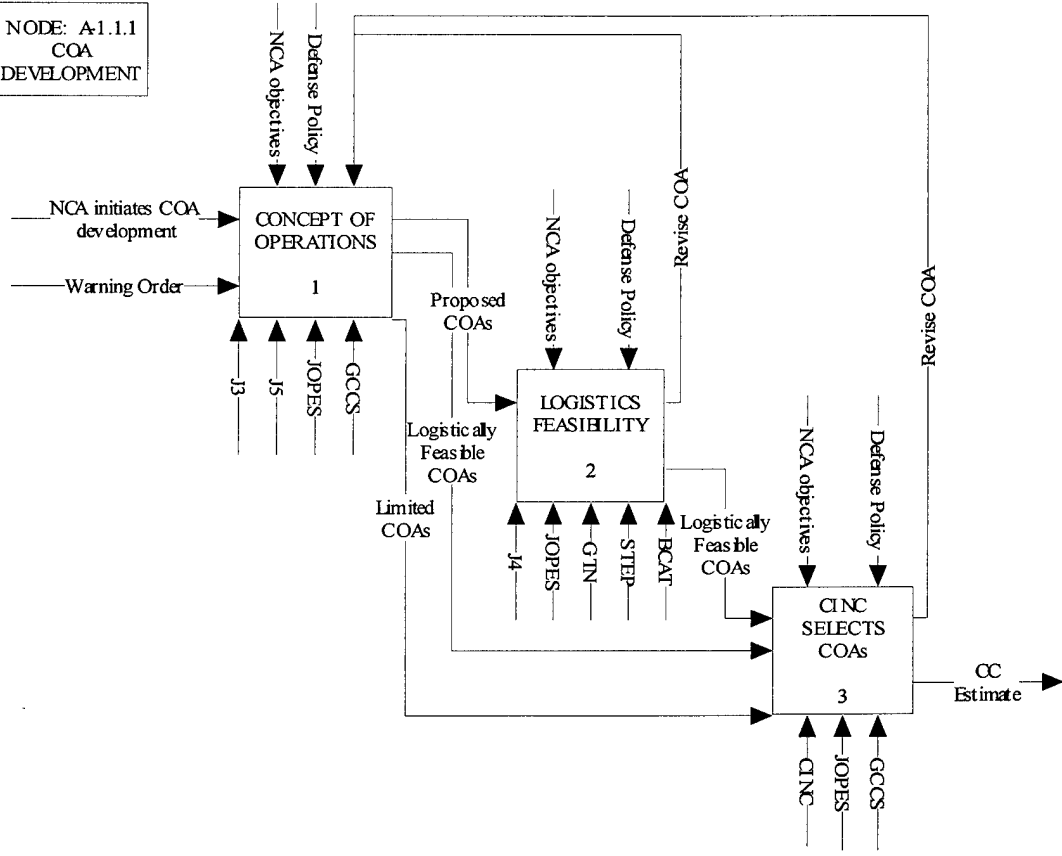

NODE: A-1.1.1.2
LOGISTICS
FEASIBILITY

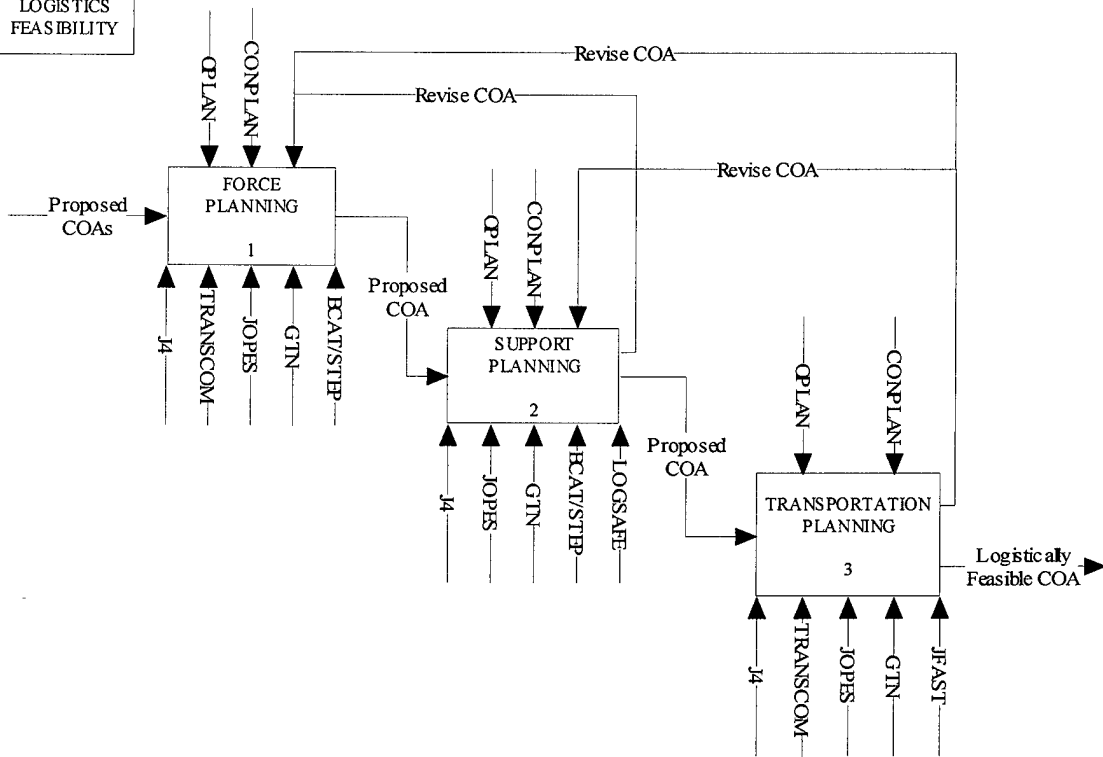

NODE: A-1.1.2
JCS COA
REVIEW

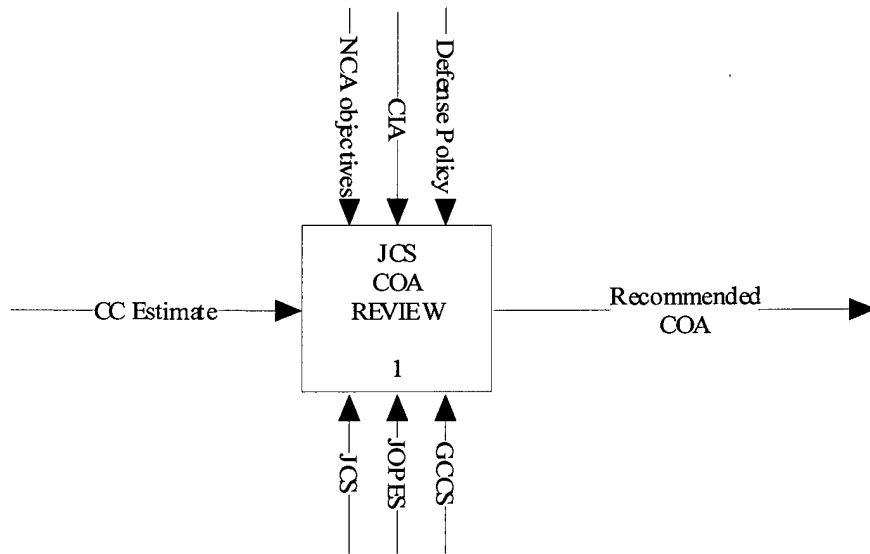

NODE: A-1.1.3
NCA COA
REVIEW

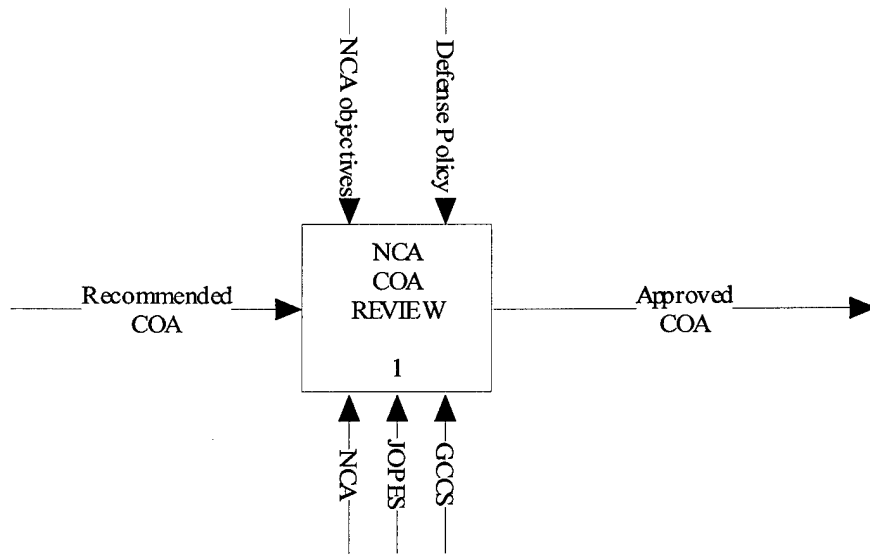

Appendix I: Knowledge Maps, CAP Phase IV

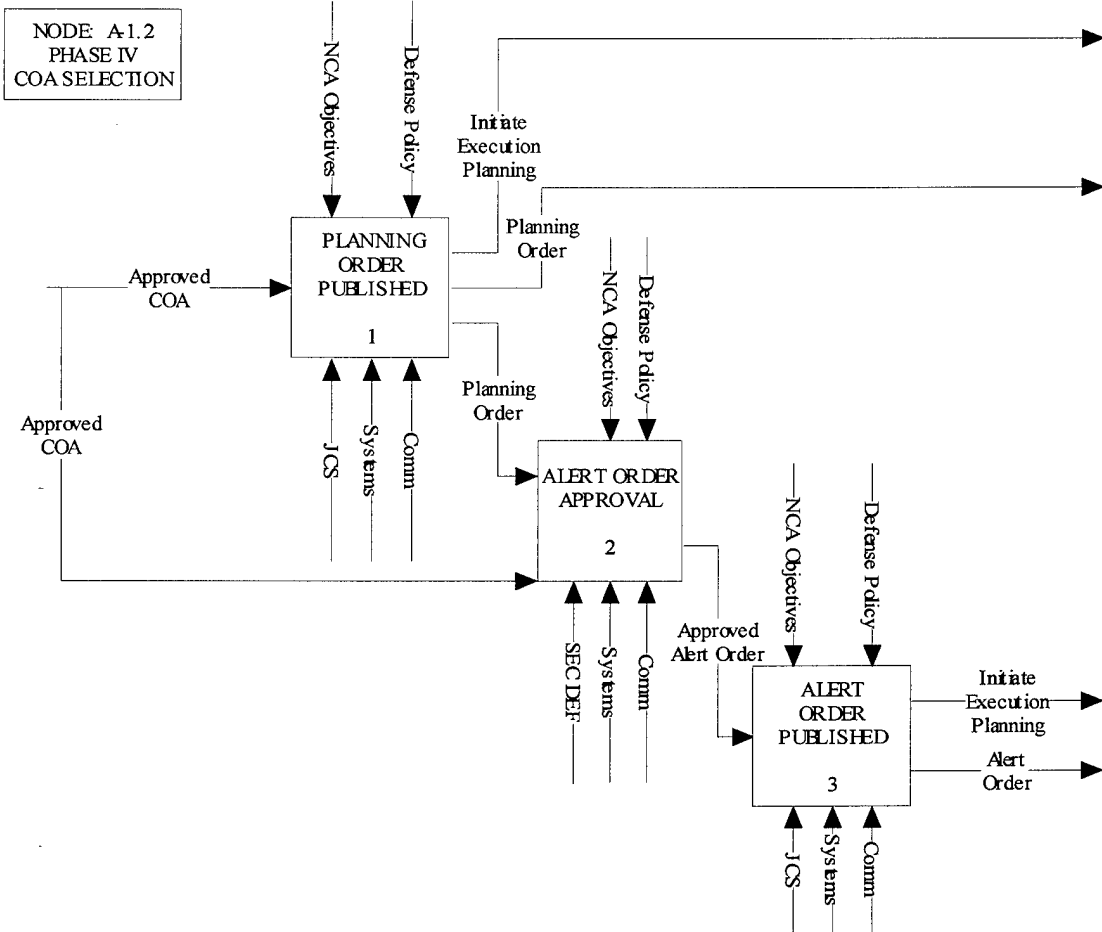

NODE: A-1.21
PLANNING
ORDER
PUBLISHED

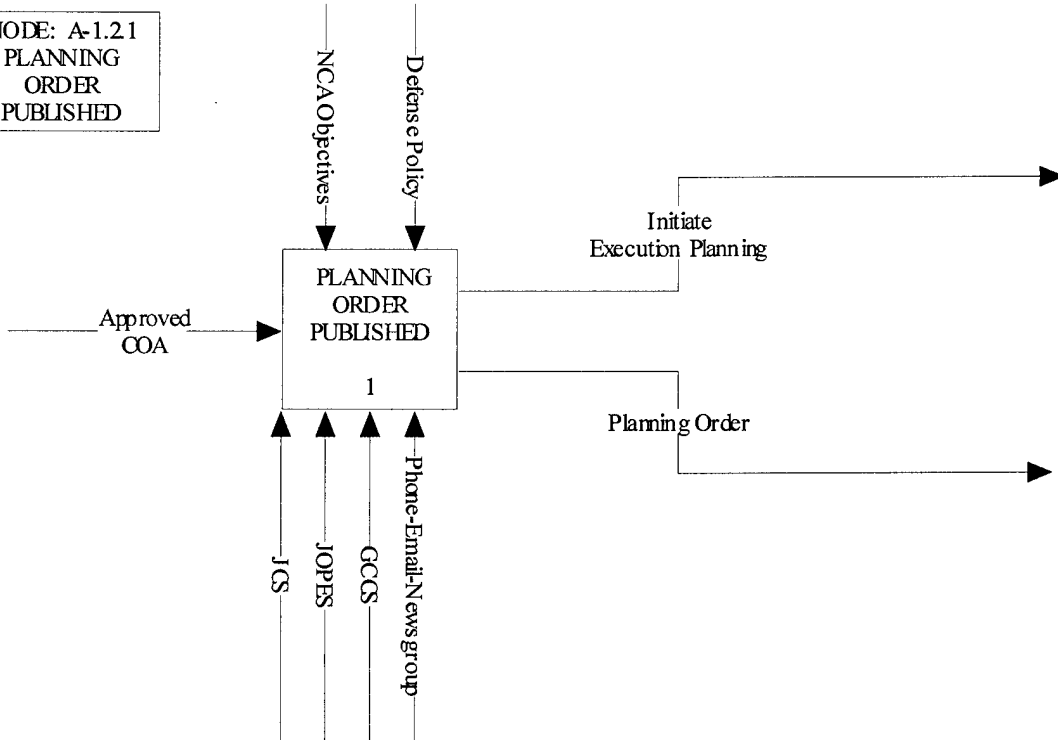

NODE A-1.2.2
ALERT ORDER
APPROVAL

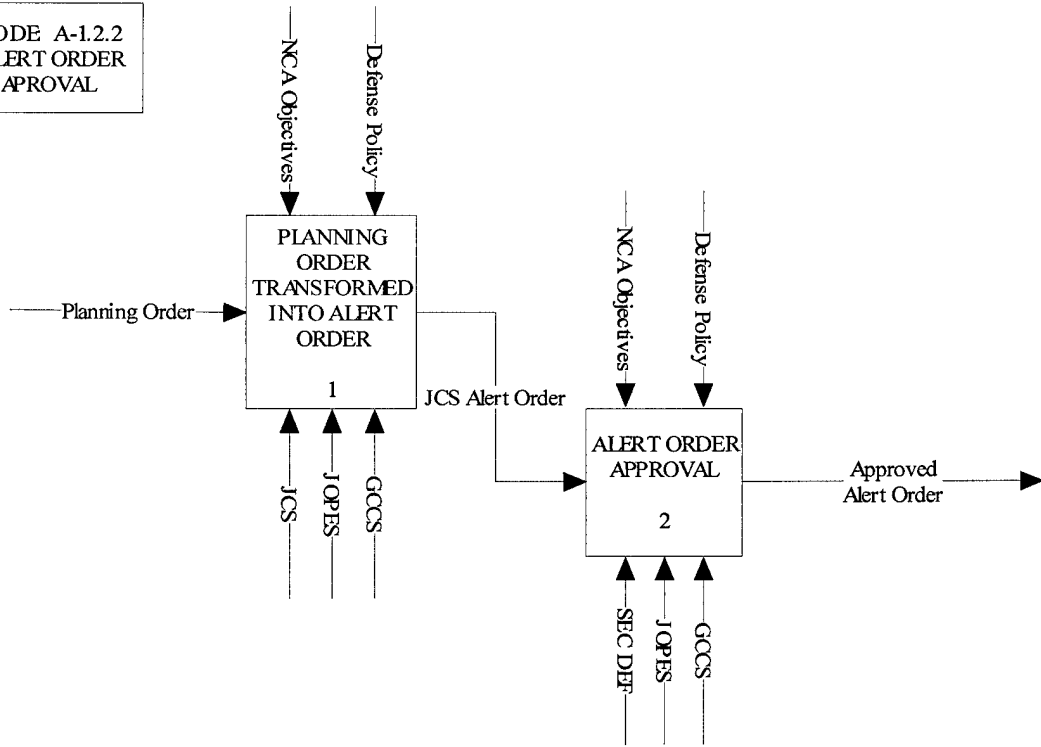

NODE: A-1.2.3
ALERT ORDER
PUBLISHED

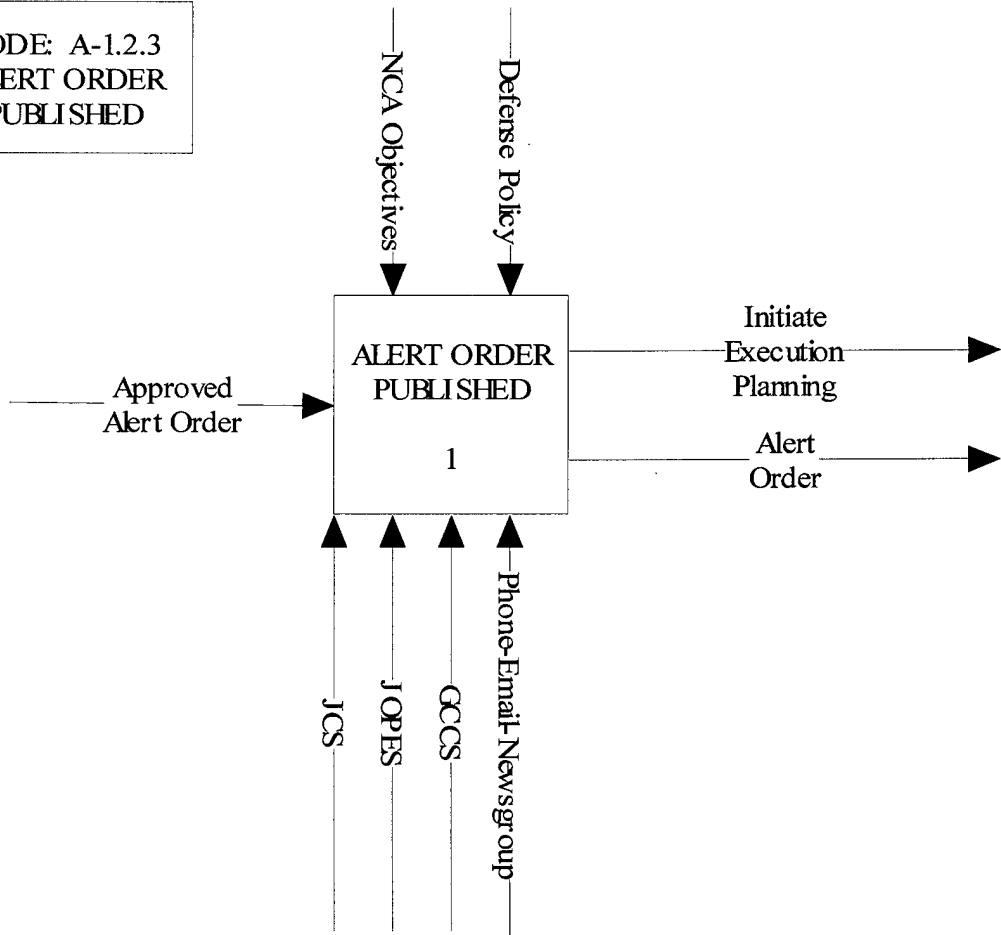

Appendix J: Knowledge Maps, CAP Phase V

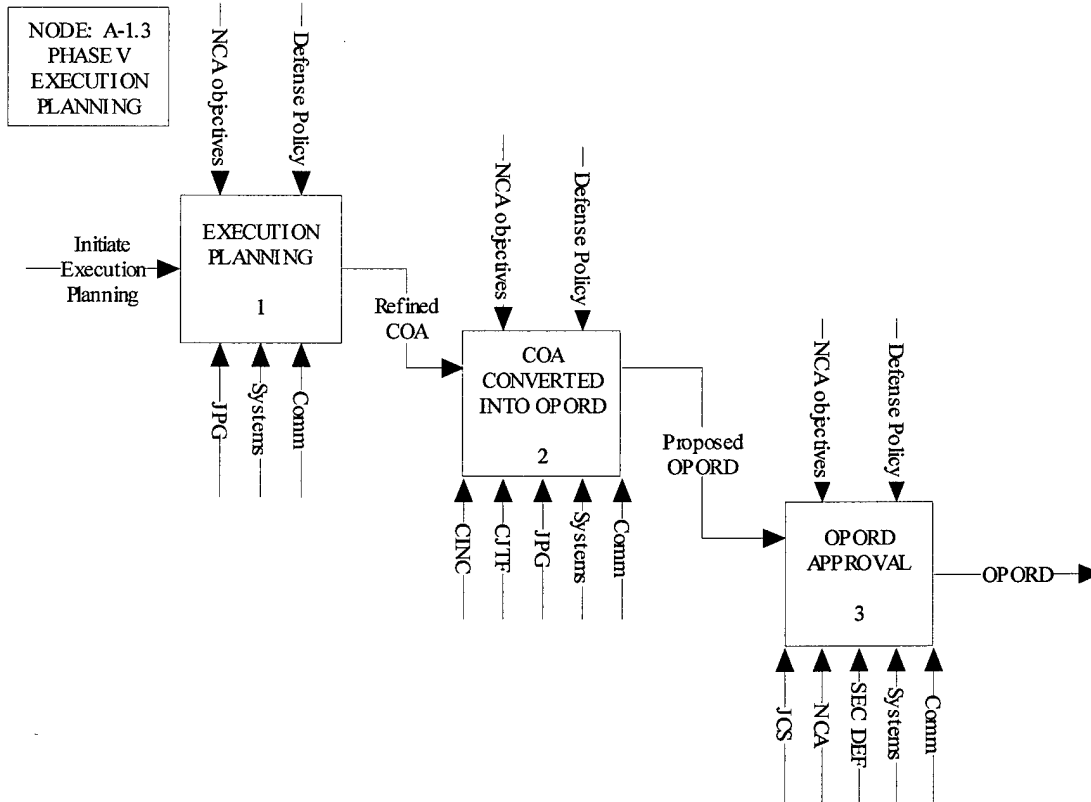

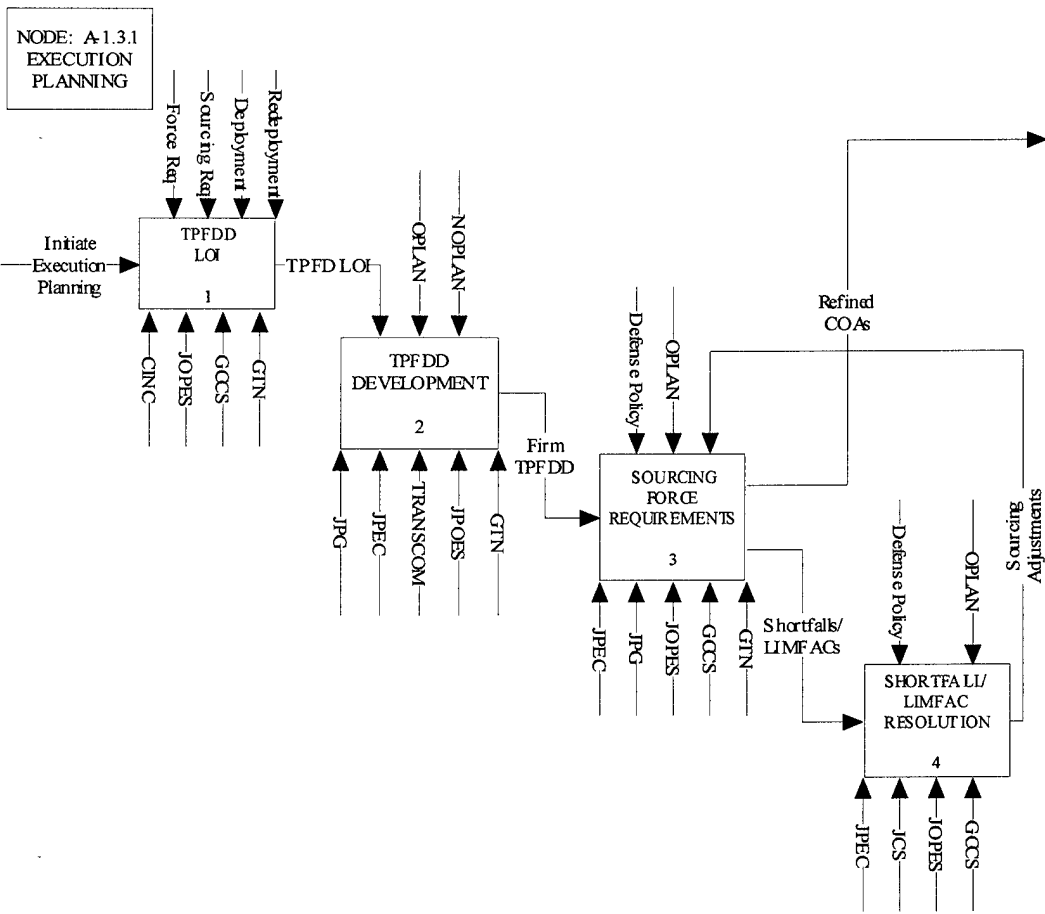

NODE: A-1.3.2
COA
CONVERTED
INTO OPORD

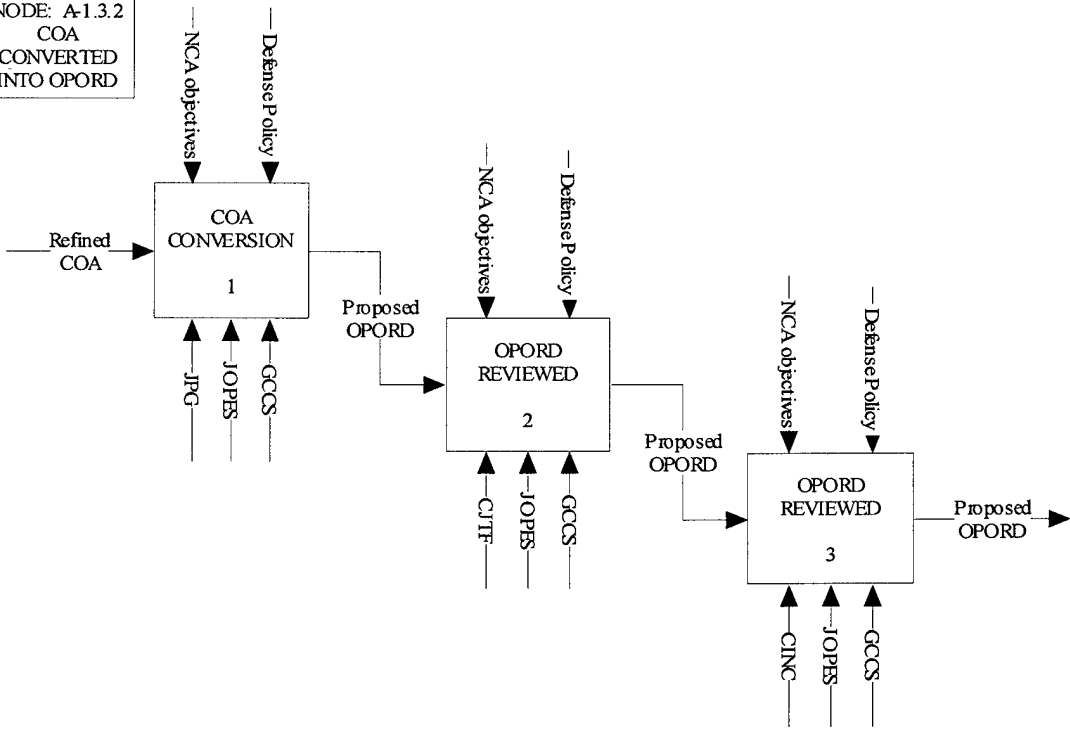

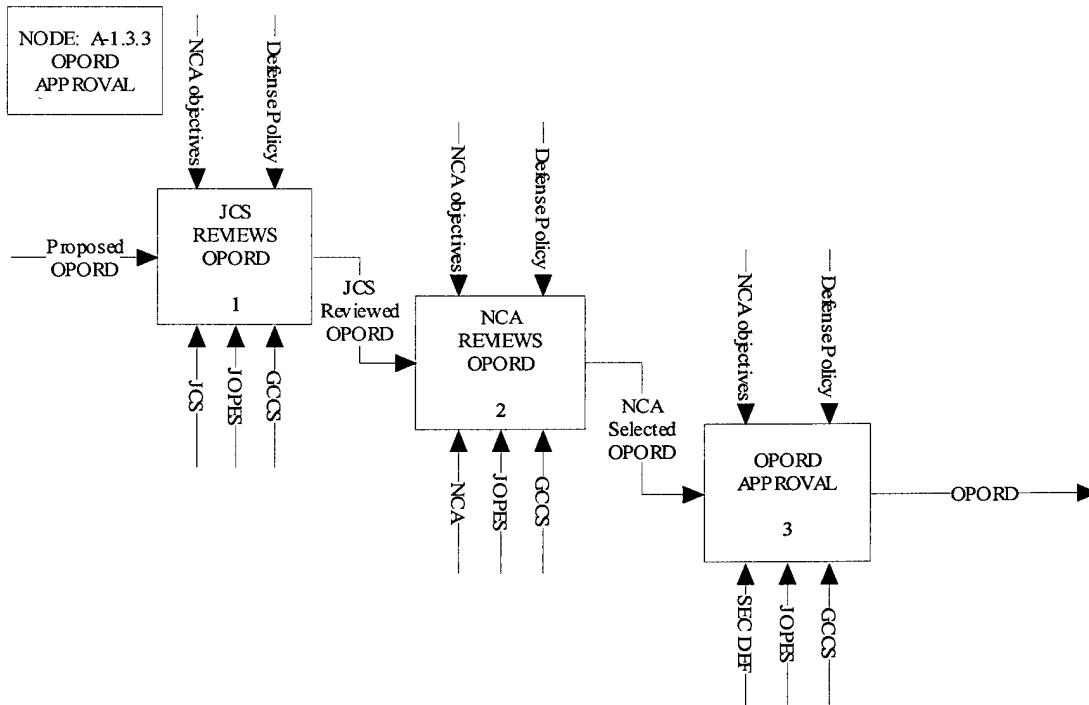

Bibliography

- Alreck, Pamela L. and Robert B. Steele. The Survey Research Handbook. New York: McGraw-Hill 1995.
- Bontis, Nick. Assessing Knowledge Assets: A review of the Models used to measure Intellectual Capital, 23 August 2000. Hamilton, Canada: Michael G. DeGroot School of Business, McMaster University.
- Boone, Christopher. Development of an Instrument to Identify Unique Supply Officer Knowledge. MS thesis, AFIT/GLM/ENS/01M-03. School of Engineering and Management, Air Force Institute of Technology, Wright-Patterson AFB OH, March 2001.
- Brooking, Annie, Peter Board, and Sue Jones. "The Predictive Potential of Intellectual Capital," Presented at the National Business Conference, Hamilton, Ontario, January 22-24, 1997.
- Carrico, Todd M. "Advanced Logistics Project." Excerpt from unpublished article, n. pg. <http://www.darpa.mil/iso/alp>. July 1999.
- Clemen, Robert T. *Making Hard Decisions*. Duxbury Press: Pacific Grove, 1996.
- Cohen, William S. "The Air Force's Air Expeditionary Forces." Excerpt from the 1998 Annual report to the President and Congress, n. pg. <http://www.dtic.mil/execsec/adr98>. 1998.
- Colorado State University. "Content Analysis." Excerpt from Colorado State University Writing Center website. pg. <http://www.colostate.edu/DEPTS/WritingCenter/references/research/content/com3b1.htm>. 26 October 2000.
- Crowe, Mattison. "Intellectual Capital for the Perplexed" Harvard Management Update. Article Reprint No. U9708C
- "Darpa Over the Years." Excerpt from unpublished article, n. pg. <http://www.arpa.mil/years.html>. 2 August 1999.
- Department of the Air Force. *Organization and Employment of Aerospace Power*. AFDD 2. Washington: HQ USAF, 28 Sept 1998.
- Department of the Air Force. *The Tongue and Quill*. AFH 37-137. Washington: HQ USAF, 31 August 1994.

- Department of the Air Force. *Aerospace Expeditionary Force Planning*. AFI 10-400. Washington: HQ USAF, 1 Dec 1999.
- Department of the Air Force. *Deployment Planning*. AFI 10-403. Washington: HQ USAF, 27 May 1998.
- Department of the Air Force. *Basic Aerospace Doctrine of the United States Air Force*. AFM 1-1. Washington: HQ USAF, 1 March 1992.
- Department of the Air Force. *Operation Plan and Concept Plan Development and Implementation*. AFM 10-401 Volume I. Washington: HQ USAF, 1 May 1998.
- Department of the Air Force. *Planning Formats and Guidance*. AFM 10-401 Volume II. Washington: HQ USAF, 1 May 1998.
- Department of Defense. *Joint Staff Officers Guide*. AFSC Pub 1. Washington: GPO, 1997.
- Department of Defense. *Command and Control of Joint Operations*. JPUB 3-56.1. Washington: CJCS, 14 Nov 1994.
- Department of Defense. *Doctrine for Command, Control, Communications, and Computer (C4) Systems Support to Joint Operations*. JPUB 6-0. Washington: CJCS, 30 May 1995.
- Department of Defense. *Doctrine for Planning Joint Operations*. JPUB 5-0. Washington: CJCS, 13 Apr 1995.
- Department of Defense. *Joint Tactics, Techniques and Procedures for Airlift Support to Joint Operations*. JPUB 4-01.1. Washington: CJCS, 20 July 1996.
- Department of Defense. *Joint Task Force Planning Guidance and Procedures*. JPUB 5-00.2. Washington: CJCS, 13 Jan 1999.
- Department of Defense. *Joint Operation Planning and Execution System Volume I (Planning Policies and Procedures)*. CJCSM 3122.01 (also Joint Pub 5-03.1). Washington: CJCS, 4 Aug 1993.
- Department of Defense. *Joint Operation Planning and Execution System Volume II (Planning Formats and Guidance)*. CJCSM 3122.03. Washington: CJCS, 4 Aug 1993.
- Department of Defense. *Joint Operation Planning and Execution System Specialty Course*. JOPES Training Organization (JTO) Training Manual Module 6-JPET. Washington: USTRANSCOM, 29 September 1998.

- Dooley, David. Social Research Methods. Third Edition. Upper Saddle River, New Jersey: Prentice Hall, 1995.
- Drucker, Peter. Knowledge Work: "Knowledge workers and e-commerce are creating new technologies, leading to major new industries," Executive Excellence. Vol. 17 Issue 4. April 2000.
- Edvinsson, Leif and Michael S. Malone. Intellectual Capital, Realizing Your Company's True Value by Finding its Hidden Roots. New York NY: Harper Collins Publishers, 1997.
- Fogelman, Ronald R. "Global Engagement: A Vision for the 21st Century Air Force." Address to the Heritage Foundation, <http://www.af-future.hq.af.mil/21/global.pdf>. 18 April 1997.
- Gordon, Steven C. "Decision Support Tools for Warfighters," Air Force Agency for Modeling and Simulation. Orlando FL: 2000.
- Grey, Denham. "*Knowledge Mapping: A Practical Overview*." Address to the Smith Weaver Smith Inc., <http://www.smithweaversmith.com/knowledge2.htm>. 02 October 1999.
- Hanrahan, Robert P. "*The IDEF Process Modeling Methodology*," <http://www.stsc.hill.af.mil/CrossTalk/1995/jun/IDEF.asp>. June 1995.
- Interviewer's Manual; Revised Edition. Survey Research Center: Institute for Social Research. University of Michigan, Ann Arbor MI. 1976.
- Judge, Paul J. The Potential Influence Of Advanced Logistics On Defense Air Transportation. MS thesis, AFIT/GMO/LAL/98J-10. School of Systems and Logistics, Air Force Institute of Technology (AU), Wright-Patterson AFB OH, June 1998.
- Leftwich, James and Michael Shaw. Final Technical Report/Study Services for Unit Type Code-Development and Tailoring (UTC-DT). Washington DC: Synergy Inc, 1997.
- Liebowitz, Jay, Bonnie Montano-Rubenstein, Doug McCaw, Judah Buchwalter, and Chuck Browning. "The Knowledge Audit," Knowledge and Process Management, Vol. 7 No. 1 (2000).
- Looney, William R. "The Air Expeditionary Force: Taking the Air Force Into the Twenty-first Century." Airpower Journal, 4-9, Winter 1996.

- Lynn, Bernadette E. "Intellectual Capital, Unearthing hidden value by managing intellectual assets." Ivey Business Journal, Vol.64 Issue 3, p48, Jan/Feb 2000.
- Macintosh, Ann. "Knowledge Management." pg. 1-7,
<http://www.aiai.ed.ac.uk/~alm/kamlnks.html>. 12 July 1999.
- McCraib, Maris. "Air Campaign Planning."
<http://www.airpower.maxwell.af.mil/airchronicales/apj/mccraib.html>. February 2001.
- Merriam-Webster's Collegiate Dictionary. <http://www.m-w.com/dictionary.htm>.
 February 2001.
- Osgood, John. "The Goldwater Nichols Act – Managing the Defense Department."
<http://pw1.netcom.com/~jrosgood/w16.htm>. 1996.
- Oxenfeldt, Alfred R. A Basic Approach to Executive Decision Making. New York: AMACOM, 1978.
- Park, Mary W. Info Think, Practical Strategies for Using Information in Business. Lanham, MD, & London: The Scarecrow Press, Inc., 1998.
- Peifer, Kenneth V. An Analysis Of Unclassified Current And Pending Air Force Information Warfare And Information Operations Doctrine And Policy. MS thesis, AFIT/GIR/LAS/97D-10. School of Acquisitions and Logistics, Air Force Institute of Technology (AU), Wright-Patterson AFB OH, December 1997.
- Quinn, Philip Anderson, and Sydney Finkelstein. "Managing Professional Intellect, making the Most of The Best," in Harvard Business Review on Knowledge Management, Boston: Harvard Business School Press, 1998.
- Swartz, Stephen. "ALP Pilot Problem and Derivation of Mathematical Model."
 Unpublished report. Wright-Patterson AFB OH, 1999.
- Vo, Tam T. Exploratory Analysis Of The Deployment Feasibility Of United States Air Force Air Expeditionary Forces. MS thesis, AFIT/GLM/LAL/97S-08. School of Systems and Logistics, Air Force Institute of Technology, Wright-Patterson AFB OH, September 1998.
- Wagner, Thomas J. "The Measurement of Human Intellectual Capital in The United States Air Force." MS thesis, AFIT/GOR/ENS/98M-26. School of Engineering and Management, Air Force Institute of Technology, Wright-Patterson AFB OH, March 1998.

Wiig, Karl M. Knowledge Management Methods, Practical Approaches to Managing Knowledge. Arlington TX: Schema Press, 1995.

Wriston, Walter. The Twilight of Sovereignty. New York: Scribner's 1992.

Vita

Captain Colvard was born in Binghamton, New York. He enlisted in the Air Force in August of 1986. From 1986-1996 he served in the Precision Measurement and Equipment Laboratory career field. He earned a Bachelor of Science in Occupational Education from Wayland Baptist University in 1995.

Upon earning his bachelors degree, Captain Colvard was accepted to attend Officers Training School in 1996. From 1996 – 1999 he served as the 16th Equipment Maintenance Squadron's Maintenance Flight Commander and concluded his tour as the 20th Aircraft Maintenance Unit's Flight Commander.

In Aug 1999, he was accepted into the Master's program at the Air Force Institute of Technology. Upon graduation, he will be assigned to the Air Education and Training Command's Logistics Group at Randolph AFB, TX.

REPORT DOCUMENTATION PAGE				<i>Form Approved</i> <i>OMB No. 074-0188</i>	
<p>The public reporting burden for this collection of information is estimated to average 1 hour per response, including the time for reviewing instructions, searching existing data sources, gathering and maintaining the data needed, and completing and reviewing the collection of information. Send comments regarding this burden estimate or any other aspect of the collection of information, including suggestions for reducing this burden to Department of Defense, Washington Headquarters Services, Directorate for Information Operations and Reports (0704-0188), 1215 Jefferson Davis Highway, Suite 1204, Arlington, VA 22202-4302. Respondents should be aware that notwithstanding any other provision of law, no person shall be subject to a penalty for failing to comply with a collection of information if it does not display a currently valid OMB control number.</p> <p>PLEASE DO NOT RETURN YOUR FORM TO THE ABOVE ADDRESS.</p>					
1. REPORT DATE (DD-MM-YYYY) 20-03-2001		2. REPORT TYPE Master's Thesis		3. DATES COVERED (From - To) May 2000 - March 2001	
4. TITLE AND SUBTITLE AN ANALYSIS OF THE INTERACTION BETWEEN THE J3 AND J4 WAR PLANNING STAFFS DURING THE PHASES OF CRISIS ACTION PLANNING				5a. CONTRACT NUMBER	
				5b. GRANT NUMBER	
				5c. PROGRAM ELEMENT NUMBER	
6. AUTHOR(S) Colvard, Michael J., Captain, USAF				5d. PROJECT NUMBER	
				5e. TASK NUMBER	
				5f. WORK UNIT NUMBER	
7. PERFORMING ORGANIZATION NAMES(S) AND ADDRESS(S) Air Force Institute of Technology Graduate School of Engineering and Management (AFIT/EN) 2950 P Street, Building 640 WPAFB OH 45433-7765				8. PERFORMING ORGANIZATION REPORT NUMBER AFIT/GLM/ENS/01M-06	
9. SPONSORING/MONITORING AGENCY NAME(S) AND ADDRESS(ES) DARPA/ISO (Dr. Todd Carrico) 3701 North Fairfax Drive Arlington VA 22203-1714 phone: (703) 526-6616				10. SPONSOR/MONITOR'S ACRONYM(S)	
				11. SPONSOR/MONITOR'S REPORT NUMBER(S)	
12. DISTRIBUTION/AVAILABILITY STATEMENT APPROVED FOR PUBLIC RELEASE; DISTRIBUTION UNLIMITED.					
13. SUPPLEMENTARY NOTES					
14. ABSTRACT A principal operational concept of Joint Vision 2020 is that of <i>Focused Logistics</i> , which promotes a merger of information and logistics technologies. The Defense Advanced Research Projects Agency's Advanced Logistics Project (ALP) supports this concept of <i>Focused Logistics</i> and seeks to leverage information technologies to obtain control over the logistics pipeline. The current campaign planning process is limited by the information made available to the decision-makers. In order for ALP to assist the decision-maker in selecting a single optimal deployment plan, the founding assumptions of alternatives considered must be valid. Logistical issues are major constraints in the war planning process. Often, when planners are faced with Crisis Action Planning (CAP) the interaction between the operations planners and the logistics planners is limited due to the time sensitivity of the situation. Because logistics information is a main constraint in the CAP process, operational planners build their plans based on inappropriate logistic assumptions. This thesis will explore the contribution that ALP's architecture could bring to the crisis action planning process. The focus of this research is to analyze the interaction between the operational and logistical communities and determine the ideal planning tool that will enhance the communication between the two communities.					
15. SUBJECT TERMS Decision Making, Decision Aids, Decision Support Systems, Crisis Action Planning, Planning, Air Logistics Support, Air Power					
16. SECURITY CLASSIFICATION OF:			17. LIMITATION OF ABSTRACT UU	18. NUMBER OF PAGES 114	19a. NAME OF RESPONSIBLE PERSON Stephen M. Swartz, Maj, USAF
a. REPORT U	b. ABSTRACT U	c. THIS PAGE U			19b. TELEPHONE NUMBER (Include area code) (937) 255-6565 x4285 (e-mail Stephen.Swartz@afit.edu)