

AD \_\_\_\_\_

Award Number: DAMD17-97-1-7150

TITLE: Altering Ets Activity to Reverse Transformation of Breast  
Cancer Cells

PRINCIPAL INVESTIGATOR: Gabriele E. Foos, Ph.D.

CONTRACTING ORGANIZATION: The Burnham Institute  
La Jolla, California 92037

REPORT DATE: January 2001

TYPE OF REPORT: Final

PREPARED FOR: U.S. Army Medical Research and Materiel Command  
Fort Detrick, Maryland 21702-5012

DISTRIBUTION STATEMENT: Approved for public release;  
distribution unlimited

The views, opinions and/or findings contained in this report are those of the author(s) and should not be construed as an official Department of the Army position, policy or decision unless so designated by other documentation.

20010620 126

# REPORT DOCUMENTATION PAGE

Form Approved  
OMB No. 074-0188

Public reporting burden for this collection of information is estimated to average 1 hour per response, including the time for reviewing instructions, searching existing data sources, gathering and maintaining the data needed, and completing and reviewing this collection of information. Send comments regarding this burden estimate or any other aspect of this collection of information, including suggestions for reducing this burden to Washington Headquarters Services, Directorate for Information Operations and Reports, 1215 Jefferson Davis Highway, Suite 1204, Arlington, VA 22202-4302, and to the Office of Management and Budget, Paperwork Reduction Project (0704-0188), Washington, DC 20503

<b>1. AGENCY USE ONLY (Leave blank)</b>		<b>2. REPORT DATE</b> January 2001	<b>3. REPORT TYPE AND DATES COVERED</b> Final (1 Jan 98 - 31 Dec 00)	
<b>4. TITLE AND SUBTITLE</b> Altering Ets Activity to Reverse Transformation of Breast Cancer Cells			<b>5. FUNDING NUMBERS</b> DAMD17-97-1-7150	
<b>6. AUTHOR(S)</b> Gabriele E. Foos, Ph.D.				
<b>7. PERFORMING ORGANIZATION NAME(S) AND ADDRESS(ES)</b> The Burnham Institute La Jolla, California 92037  E-Mail: <a href="mailto:gfoos@LJCRF.edu">gfoos@LJCRF.edu</a>			<b>8. PERFORMING ORGANIZATION REPORT NUMBER</b>	
<b>9. SPONSORING / MONITORING AGENCY NAME(S) AND ADDRESS(ES)</b> U.S. Army Medical Research and Materiel Command Fort Detrick, Maryland 21702-5012			<b>10. SPONSORING / MONITORING AGENCY REPORT NUMBER</b>	
<b>11. SUPPLEMENTARY NOTES</b> This report contains colored photos				
<b>12a. DISTRIBUTION / AVAILABILITY STATEMENT</b> Approved for Public Release; Distribution Unlimited				<b>12b. DISTRIBUTION CODE</b>
<b>13. ABSTRACT (Maximum 200 Words)</b>  The Ets family of transcription factors are downstream targets of several activated signal transduction steps identified in breast tumors. Interfering with Ets-dependent transcription by expression of the Ets2 DNA binding domain (Ets2DBD) reverses Ras-mediated NIH3T3 cell transformation. We hypothesized that altering Ets activity could also effectively reverse the transformed phenotype of breast cancer cells. We analyzed the effects of stably expressing different Ets2 constructs in Ras-transformed NIH3T3 (DT-3T3) cells and in a human breast cancer cell line, MDA-MB-435. Expression of the dominant inhibitory Ets2DBD caused loss of anchorage independent growth in both cell types. Unexpectedly, high expression of the transcriptional activators full-length Ets2 or VP16Ets2, broadly reversed the transformed properties of DT-3T3 cells, including anchorage independent growth, transformed morphology, and tumorigenicity. In MDA-MB-435 cells, overexpression of either Ets2 or Ets2DBD not only lead to anchorage dependence, but also drastically decreased their <i>in vitro</i> invasiveness. Breast tumor cells with altered Ets function exhibited distinct changes in expression of several genes associated with invasiveness, such as the matrix metalloproteinases (MMPs). These results suggest that the balance of Ets factors is important for maintaining multiple aspects of the transformed phenotype of breast tumor cells, and are an appropriate target for intervention.				
<b>14. SUBJECT TERMS</b> Breast Cancer, Ets2 overexpression, dominant negative Ets2, Transformation			<b>15. NUMBER OF PAGES</b> 62	
			<b>16. PRICE CODE</b>	
<b>17. SECURITY CLASSIFICATION OF REPORT</b> Unclassified	<b>18. SECURITY CLASSIFICATION OF THIS PAGE</b> Unclassified	<b>19. SECURITY CLASSIFICATION OF ABSTRACT</b> Unclassified	<b>20. LIMITATION OF ABSTRACT</b> Unlimited	



## **TABLE OF CONTENTS:**

FRONT COVER	p. 1
STANDARD FORM 298	p. 2
FOREWORD	p. 3
TABLE OF CONTENTS	p. 4
INTRODUCTION	p. 5
OBJECTIVE 1	p. 6
OBJECTIVE 2	p. 8
OBJECTIVE 3	p. 9
KEY RESEARCH ACCOMPLISHMENTS	p. 15
REPORTABLE OUTCOMES	p. 15
SUMMARY AND CONCLUSIONS	p. 16
REFERENCES	p. 17
APPENDICES	

## INTRODUCTION AND BACKGROUND

Breast cancer is one of the major causes of death in women. Cancers occur as a result of multiple genetic alterations leading to a tumorigenic phenotype. One frequently found alteration in human tumors is the constitutive activation of the Ras signaling pathway. Constitutive Ras signaling can lead to widespread changes in cellular growth and behavior. While direct mutation of Ras genes is not frequently found in breast cancer, a variety of other defects which lead to constitutive Ras signaling have been found. To date the majority of cellular downstream targets of oncogenic Ras leading to the fully transformed phenotype is still unknown. Some of the most downstream targets that have been characterized are transcription factors, like the members of the Ets family of transcription factors, whose alterations can lead to widespread changes in gene expression. These Ets factors share a conserved DNA binding domain. The transcriptional activity of the Elk family of Ets ternary complex factors are regulated by Neu/Ras/Raf/MEK/MAP kinase pathway (1). We found that Ets1 and Ets2 are transcriptionally activated by Neu/erbB-2 and Ras (2-4). In addition to activating members of the Ets family, there are also negative regulators of transcription like ERF or Net, whose negative regulation can be relieved by stimulation of the Ras signaling pathway (5,6).

**Role of the Ets family in cellular transformation.** In rodent fibroblasts, it has been shown that Ets factors are essential targets in cellular transformation. Most of the dominant negative mutants that block Ras-mediated transformation also block activation of reporter genes that contain Ets and AP-1 sites. Dominant inhibitory mutants of Ets or AP-1 can reverse Ras-or Neu/HER2 mediated cellular transformation in rodent fibroblasts (4,7,8). A dominant inhibitory mutant, consisting of the DNA binding domain alone can act as a broad inhibitor of Ets function, since Ets factors bind to the same consensus sites. These data suggest, that Ets factors are critical for mediating effects of more upstream, non-nuclear oncogenes.

**Dominant inhibitory Ets proteins can reverse the transformed phenotype of tumor cell lines.** A dominant inhibitory mutant for AP-1 can inhibit the transformation of epithelial- and breast cancer cell lines (9). It has been shown that overexpression of Ets1 in the human colon cancer cell line DLD-1 could reverse the transformed phenotype of these cells (10). Another study showed that Ets2 plays a critical role in regulation of anchorage independent growth of BT20 breast cancer cells (11). These findings, that altering Ets function can indeed revert more complex epithelial-derived cancers, encouraged me to investigate whether expression of distinct parts Ets2 can reverse the transformed phenotype of epithelial-derived breast tumor cell lines.

**Ets factors and metastasis.** Several promoters of known metastasis associated genes contain Ets and AP-1 sites (12). The expression of some of these genes, like the metalloproteinases collagenase, stromelysin (13,14), and the urokinase-type plasminogen activator uPA are increased by activated Ras. Our lab showed that the uPA promoter can strongly be activated by Ets and Ras (3). In addition, the enhancer for keratin 18 also contains Ras and Ets responsive elements (15). Keratin 18 is a diagnostic marker for 90% of invasive breast carcinomas. Thus, I have undertaken the characterization of the effects of altered Ets function on the invasiveness of breast cancer cell lines.

### Objectives and Hypothesis

The goal of this proposal is to determine whether altering Ets activity can specifically reverse the transformed phenotype of a model cell line or breast cancer cell lines. This analysis will provide insight as to whether the Ets family of transcription factors are novel downstream targets for potential therapeutic intervention in breast cancer.

The hypotheses are: 1) that Ets factors are downstream targets for signal transduction pathways in breast cancer cells and 2) that interfering with Ets transcription factors, by overexpressing different mutant forms of Ets2, can specifically reverse the transformed phenotype and/or metastatic potential of breast cancer cell lines.

**Progress:** Considerable progress has been made towards all 3 objectives.

**Objective 1: Comparison of the effect of Ets2 mutants in reversing the transformed phenotype of rodent fibroblasts and human epithelial breast cells.**

**Milestone 1: Generation of stable Ets-expressing DT-3T3 cell lines.** To characterize the role of Ets factors in Ras-mediated cellular transformation, several Ets2 mutant constructs were generated, including expression vectors for the Ets2DNA Binding domain (Ets2DBD), the Ets2 transactivation domains (Ets2TAD), or a construct containing the VP16 transactivation domain fused to full-length Ets2 (VP16Ets2). As a model system, I chose the v-Ki-Ras transformed NIH3T3 cell line (DT-3T3) (16). I generated DT-3T3 cell lines, stably overexpressing the different Ets2 mutants. To improve the frequency of G418 resistant clones, I used the pCIN4 vector (17). At least 6 individual clones per construct were randomly picked and expanded to analyze (about 100 clones total). Although this approach was very time consuming, it was useful to identify the Ets2 mutants with the highest reversion potential. This detailed analysis formed the basis for the subsequent objectives below.

**Milestone 2: Determination of the protein levels of Ets2 constructs in the reverted cell lines.** All of the G418 resistant and expanded clones of full-length Ets2, the Ets2DBD, Ets2TAD and VP16 Ets2 expressed amounts of proteins that were detectable by western blot (data not shown). The FLAG tagged proteins were assayed by using the an anti-FLAG antibody. To investigate whether the reversion activity of Ets2 is due to transcriptional activation, I fused the VP16 transactivation domain to full-length Ets2, creating a very powerful transcriptional activator.

**Milestone 3: Expression of different Ets2 constructs leads to loss of anchorage independent growth of DT-3T3 cells.** As one important parameter of cellular transformation, I measured the ability of the stable DT-3T3 cell lines to exhibit anchorage independent growth in soft agar. The number of soft agar colonies formed by the different stable clones were compared to the number of colonies formed by the control cell lines expressing the empty vector pCIN. As expected, the clones expressing the Ets2DBD showed reduced growth in soft agar, but surprisingly, 7 out of 11 cell lines overexpressing the transcriptional activator full-length Ets2, showed a more than 4-fold reduction in soft agar growth (fig. 1A, 1B). Most of the clones expressing the Ets2TAD also showed reduction in soft agar growth. None of the stable cell lines showed any changes in attached cell growth on regular tissue culture dishes. In addition, the growth rate of these cell lines did not show any difference in their exponential growth, but consistent with their reverted phenotype, Ets2 or Ets2DBD cell lines showed lower saturation densities. There was a direct correlation between the amount of colonies growing in soft agar and the expression level of the proteins.

To determine how much Ets2 overexpression is needed to achieve reversion of cellular transformation in these cell lines, I performed RNase protection experiments. For the Ets2 overexpressing lines, a 10-fold overexpression is needed to effectively revert these cells (19). For the VP16Ets2 construct expressing lines, I found that they were expressing 4-fold more protein than the best reverted full-length Ets2 cell line Ets2full#5. Since the VP16Ets2 lines have higher stable protein levels, I cannot exclude that the stronger reversion activity of this construct might simply be due to the more stable VP16Ets2 protein.

**Morphological reversion of DT-3T3 cells by overexpression of full-length Ets2, the Ets2DBD but not Ets2TAD.** Ras transformed DT-3T3 cells do not show the characteristic organization of actin filament structure seen in untransformed NIH3T3 fibroblasts. In order to analyze the actin filament organization in DT-3T3 cells and in the reverted lines, I stained them with rhodamine conjugated phalloidin. The full-length Ets2 overexpressing lines, and the Ets2DBD lines showed nicely reorganized actin filament structures, consistent with their morphological appearance (fig.2). In contrast, the Ets2TAD expressing lines did not show any morphological reversion and no actin filament reorganization, suggesting different targets of these Ets2 constructs.

**The Ets2 (thr72) residue is not required for reversion activity.** We previously showed that phosphorylation of the Ets2 (T72) residue is essential for the large Ras pathway-mediated increase in Ets2 transactivation activity, and that an Ets2(A72) mutant retained basal transcriptional activity, but lost Ras-responsiveness (4,18). To test the connection between Ras signaling to Ets2 and the ability of expressed Ets2 to revert transformation, I determined whether expression of Ets2TAD(A72) or full-length Ets2(A72) could reverse the anchorage-independent growth or transformed morphology of DT-3T3 cells. As described above for the wild-type Ets2 constructs, I generated multiple stable DT-3T3 cell lines that overexpress Ets2(A72) or Ets2TAD(A72). These cells were tested for their ability to grow in soft agar. While introduction of the (A72) mutation caused a modest reduction in apparent reversion activity, both the full-length Ets2(A72) and the Ets2TAD(A72) constructs still clearly caused significant decreases in anchorage-independent growth. The soft agar growth analysis of three cell lines containing either the Ets2TAD(A72) or the Ets2(A72) expression constructs (fig. 1A) revealed an over 4-fold reduction in anchorage-independent growth, indicating that phosphorylation of Ets2 (thr72) was not essential for their reversion activity. Parallel plating experiments on tissue culture dishes and growth rate analysis demonstrated, that the reduced soft agar colony formation in these cell lines was not due to a reduced cell growth rate or altered plating efficiency. Analysis of the effects of full-length Ets2(A72) or the Ets2TAD(A72) on cell morphology and actin stress fibers revealed, that these (A72) constructs had the same effect as their wild-type counterparts: the full-length Ets2(A72) cell lines appeared reverted, and the Ets2TAD(A72) cell lines did not (data not shown).

**Ets2 constructs act downstream of MAP kinase activation.** In order to verify that the overexpression of the different Ets2 constructs do not revert the DT-3T3 cells by simply downregulating Ras expression, I confirmed the Ras expression in western blot analysis using the pan-Ras antibody. All of the tested lines showed the same amount of Ras expression. By using an immune complex assay, I found that there was no significant change in the basal level of ERK activity in the control cell lines and the reverted cell lines, indicating that Ets2 acts downstream of the MAP kinases Erk1 and Erk (19).

**Milestone 4: Effect of the MAPK inhibitor PD098059 on reversing the transformed phenotype of DT-3T3 cells.** As a model for small molecule inhibitors of downstream signaling, I tested the effect of the MEK activation inhibitor PD098059 on the RAS transformed fibroblasts. This compound blocks activation of MEK. I tested the effect of 3 different concentrations (10, 30, and 100 $\mu$ M) on attached growth and soft agar growth. Even at the highest concentration tested, this compound did not have any effect on attached or soft agar growth of these cells (fig. 3).

## **Objective 2: Reversion of the transformed phenotype of breast cancer cell lines.**

### **Milestone 5: Establishing breast cancer cell lines expressing Ets2 mutants.**

The extensive analysis in objective 1 helped me to identify the Ets2 constructs that are potent in reverting the transformed phenotype of DT-3T3 cell. My first attempt to alter Ets function in breast tumor cells was to establish highly invasive MDA-MB-435 cell lines stably overexpressing full-length Ets2, Ets2DBD, VP16Ets2 or the empty vector pCIN by lipofectamine transfection. For full-length Ets2, I obtained only about 10% of G418 resistant colonies, relative to the transfection with Ets2DBD. I could not establish any VP16Ets2 expressing MDA-MB-435 lines. Most of the G418 resistant colonies for full-length Ets2 could not be expanded, as the clones rounded up and eventually died. After testing various cultivation conditions, I found that MDA-MB-435 conditioned media helped the G418 resistant full-length clones and I was able to obtain a number of Ets2 overexpressing MDA-MB-435 lines. Western blot analysis of 7 Ets2DBD lines showed a wide range of EtsDBD expression (fig 4). The protein expression of all 7 tested full-length Ets2 lines was comparably low. Taking these problems into account, I hypothesized that high expression of the full-length Ets2 and particularly VP16 Ets2 was toxic to MDA-MB-435 cells. Therefore it is difficult to find an amount of protein that does not kill these cells, but that is high enough to show biological effects. Similar problems were seen in a collaborative effort where my Ets2 constructs were introduced into a prostate tumor cell line, and these Ets2 constructs inhibited growth and induced apoptosis (21)

Such technical difficulties caused me to scale back the number of different stable mammary tumor cell lines to be analyzed, and to focus on characterizing the MDA-MB-435 lines. While focusing on the hormone-independent MDA-MB-435 tumor cell line has the limitation that one can not study hormone-dependent processes, it has the advantage that unlike MCF-7, this tumor cell line is highly invasive. I felt that the analysis of invasive behavior was particularly important, both because of its extreme clinical relevance, and because many genes associated with invasiveness are thought to be regulated by Ets transcription factors.

As another approach to overcome the problem of Ets-construct toxicity in MDA-MB-435 cells, I generated inducible cell lines for full-length Ets2 and Ets2DBD by using Clontech's Tet-On gene expression system. This system permits gene expression to be tightly regulated in response to varying concentrations of doxycycline. The first component of the Tet-System is the regulatory protein, based on TetR. The initial step was to generate stable Tet-On carrying MDA-MB-435 cell lines. To screen these stable cell lines I performed transient transfection assays with pTRE2-Luc to identify G418-resistant clones that meet the criteria for good Tet-On cell lines. I analyzed 9 different lines for good inducibility. In a second transfection, the second critical component, the response plasmid (pTRE2), which expresses Ets2, VP16Ets2, or Ets2DBD under control of the tetracycline-response element got stably introduced into the MDA-MB-431 Tet-On cell line. G418 and hygromycin resistant clones were expanded and tested for protein inducibility by western blot. I established inducible lines for all the three constructs: full-length Ets2, Ets2DBD and VP16 Ets2.

### **Milestone 6: Expression of full-length Ets2 or the Ets2DBD in MDA-MB-435 cells inhibits anchorage-independent growth in soft agar.**

I tested the stable MDA-MB-435 cell lines for their ability to grow in soft agar. In order to exclude clonal variations, I tested 4 control lines, containing only the empty vector, 8 clones expressing the dominant inhibitor Ets2DBD and 10 full-length Ets2 expressing clones. Two full-length Ets2 clones showed a more than 50% reduction of soft agar growth, and four of the clones showed complete inhibition in soft agar growth. For the

Ets2DBD clones, 50% of the clones showed a more than 70% reduction in soft agar colony formation. None of the tested control lines showed a significant reduction in soft agar growth (fig. 6).

I also performed soft agar assays for MDA-MB-435 cell lines containing the inducible constructs for Ets2, VP16 Ets2 and Ets2DBD. Prior to the experiment, the cells were grown in the absence of doxycycline (Dox). At the time of plating, the cells were trypsinized, counted and split on dishes with or without 2 ng/ml of Dox. Figure 5 shows that induction of each of these Ets2 proteins led to drastic reduction in soft agar growth. These inducible cell lines form an excellent system for future studies of the mechanisms and targets involved in the reversal of the transformed phenotype of MDA-MB-435 cells following perturbation of Ets transcription factor function.

**Milestone 7: Effect of PD098059 on reversing the transformed phenotype of MDA-MB-435 cells.**

I tested the effect of MEK inhibitor PD098059 on attached and soft agar growth of the MDA-MB-435 cells. In contrast to the results for the DT-3T3 cells, where PD098059 had no measurable effect on soft agar growth even at the highest concentration tested, even the lowest concentration of PD098059 (10 $\mu$ M) tested strongly inhibited both, soft agar and attached cell growth (fig. 7). Thus, the growth of this mammary tumor cell line is strongly influenced by general MAP kinase signaling, as well as more specific inhibition of one of the targets of the MAPK pathway, Ets transcription factors.

**Decreased motility in cell lines expressing Ets2 constructs.** I examined the motility of the MDA-MB-435-derived cell lines through an 8 $\mu$ m pore uncoated filter in response to a serum gradient. As shown in figure 8A, MDA-MB-435 cells expressing either full-length Ets2 or Ets2DBD showed an increase in motility compared to the parental cell line MDA-MB-435. As shown in fig 8A, an average of 350 MDA-MB-435 cells per counted field migrated through the membrane in 24 hours, using DMEM media containing 10% FBS as chemoattractant. In contrast, the average amount of full-length Ets2 or Ets2DBD cells per field migrating through the membrane was 550.

**Overexpression of Ets2DBD or full-length Ets2 in MDA-MB-435 cells blocks *in vitro* invasion.** The ability to invade through basement membranes is an important step in the metastatic process. I assayed the *in vitro* invasion potential of MDA-MB-435 cells expressing full-length Ets2 or Ets2DBD, by measuring their ability to traverse through filters coated with reconstituted basement membrane (Matrigel). DMEM media containing 10% FBS was used as a chemoattractant. Figure 8B shows that the cell lines expressing full-length Ets2 or the Ets2DBD exhibited significantly reduced invasiveness in these assays, compared to the parental cell line. This loss of invasiveness is particularly striking, because, as described above, these cell lines actually exhibited increased motility.

**Objective 3: *In vivo* analysis of the reversion of tumorigenicity and metastasis induced by Ets2 mutants.**

**Milestone 8: Ets2 expression reduces tumorigenicity of DT-3T3 cells in nude mice.** To determine whether the Ets2-mediated morphological reversion or increased anchorage-dependence of the Ets-mutants overexpressing DT-3T3 cells seen *in vitro* reflects a reduced ability to form tumors, I performed tumorigenicity assays in nude mice. I injected the parental DT-3T3 cells, clones that are expressing full-length Ets2, the EtsDBD, VP16Ets2, Ets2TAD or lines that carry the empty expression vector into the left and right dorsal flank of 4 weeks old nude mice. Tumor growth was measured externally by caliper and the average tumor volume in mm<sup>3</sup> was determined. The numbers in Table

1 represent the average of 6-8 tumors derived from each cell line. There was no significant difference in tumor growth for both of the pCIN lines that I tested. However, the tumor volumes were significantly smaller than pCIN#5 for both full-length Ets2 cell lines and both VP16-Ets2 cell lines on days 6, 8, and 10. Reductions in tumor growth were also seen in the Ets2TAD#53 and Ets2DBD#10 cell lines, but the smaller tumor volumes were statistically significant only on days 6 and 8 for the Ets2TAD line and only on day 8 for the Ets2DBD line. Due to the very high initial growth rate of the control cell lines, by day 10, the tumors from pCIN or parental DT cells were quite large, and started to exhibit reduced growth rates. This allowed the delayed tumors derived from the Ets2 construct-containing cell lines to catch up, and by days 12 and 14, none of the tumor volumes were significantly different from those of the pCIN#5 line (data not shown). It is likely that the delayed tumor growth of the Ets mutant-expressing lines represent the *in vivo* effect of these Ets proteins, and that the absence of G418 selection in the *in vivo* experiment lead to subsequent selection of cells in which expression from the pCIN vector is reduced. Indeed, our analysis of gene expression in the delayed tumors that arose confirmed, that expression of the Ets constructs was almost completely lost in these tumor cells (19). Taken together, the ability of the activating constructs Ets2 or VP16Ets2 to cause substantial delay in tumor formation, and the Ets2DBD to cause a delay in tumorigenicity correlates with their ability to revert the transformed phenotype in *in vitro* experiments. However, because of the dramatic *in vivo* instability of Ets construct expression in our model cell system, as well as similar results by others examining the effects of growth-inhibitory genes, we concluded that *in vivo* tumorigenicity analysis in MDA-MB-435 cells would likely not be fruitful. Thus, we instead focused our efforts on the *in vitro* analysis of the Ets construct-mediated reversal of MDA-MB-435 cell transformation, and to extend our analysis to characterizing possible downstream targets involved in this process.

**Possible mechanism of phenotypic reversion of MDA-MB-435 cells by expressing distinct Ets2 mutants.** As a first attempt to gain some insight into the mechanism of how the different Ets2 constructs might lead to loss of anchorage independent growth, I performed transient transfection experiments of full-length Ets2, Ets2DBD or the empty pCIN vector with several Ets-dependent reporter genes in parental MDA-MB-435 cells. Figure 9 clearly shows that Ets2 can activate E.18, an Ets-dependent reporter gene that contains two Ets binding sites, up to 17.5 fold. The dominant inhibitor of Ets-dependent transcription, Ets2DBD, is able to inhibit the expression of this Ets-responsive reporter gene. Overall, we found the transcriptional behavior of the Ets2 constructs in the MDA-MB-435 cells quite similar to that in NIH3T3 cells (21).

As a broader approach of trying to identify potential targets that are involved in Ets2 construct-mediated reversion of MDA-MB-435 cells to more normal growth and dramatically reduced invasiveness, I initiated cDNA microarray analysis. Fig 10 shows the image of a hybridization comparing the expression pattern of the parental MDA-MB-435 cell line to the cell line Ets2DBD/A. Several interesting genes implicated in changes in migration or invasion that were differentially expressed in the Ets2DBD expressing line were identified, and several of these have been followed up with further analysis.

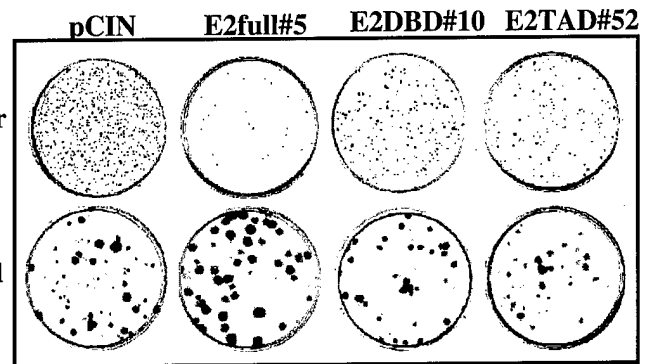
A key group of gene products involved in invasiveness are the matrix metalloproteinases (MMPs), and their regulators, the tissue inhibitors of metalloproteinases (TIMPs). Following up cDNA microarray results, real-time PCR analysis was performed using a LightCycler instrument to quantitate observed changes in MMP and TIMP expression. Consistent with the model we postulated (19), distinct changes in gene expression were observed in the MDA-MB-435 breast tumor cells whose invasiveness was reduced by expression of either the Ets2DBD or by full-length Ets2. In the Ets2DBD-expressing cell lines, significantly reduced expression (over 3-fold) was seen for both MMP1 and

MMP3, while elevated expression of TIMP2 was seen. Both MMP1 and MMP3 have Ets factor binding sites in their promoters, suggesting that these changes may reveal a direct role for altered Ets function in reducing MDA-MB-435 cell invasiveness. In the full-length Ets2 expressing MDA-MB-435 breast tumor cells, the expression of both MMP1 and 3 were elevated 2-fold in the full-length Ets2 overexpressing line. However, in addition, the expression of TIMP1, a negative regulator of MMP activity was significantly elevated, as was the cell cycle kinase inhibitor p21<sup>waf/cip</sup>. In Ras-transformed fibroblasts, elevated p21<sup>waf/cip</sup> expression has previously been shown to block anchorage-independence, and high-level p21<sup>waf/cip</sup> expression causes growth arrest. Thus, the altered behavior in Ets2 overexpressing cells may be due to additional changes in gene expression which could override increased MMP function (e.g. TIMP1) or increased growth signaling (e.g. p21<sup>waf/cip</sup>).

DT cells transfected with:	Number of stable lines with indicated soft agar colony formation (relative to DT)			
	>50%	25-50%	10-25%	<10%
pCIN	5	0	0	0
Ets2full	2	1	4	4
Ets2DBD	6	1	5	3
EtsTAD	1	0	4	2
E2TADA72	1	2	2	1
E2FullA72	0	2	2	1
VP16-E2full	0	0	0	10
VP16 only	6	1	0	2

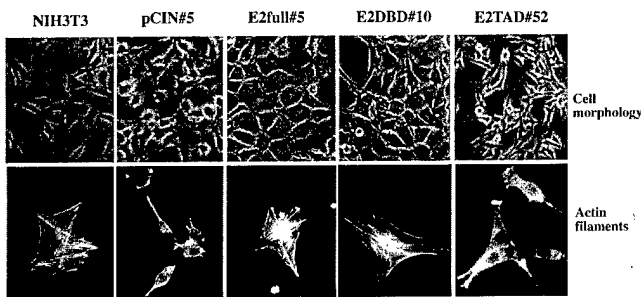
Soft Agar Colonies

Attached Colonies

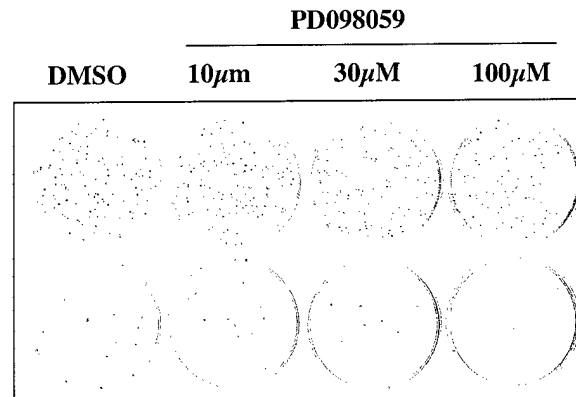


**Figure 1A:**  
Soft agar and attached growth of individual stable DT-3T3 clones

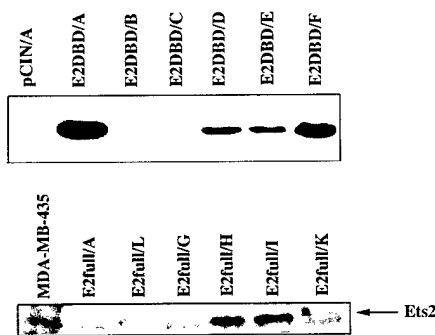
**Figure 1B:** Percent soft agar colony formation relative to DT-3T3 cells



**Figure 2.** Expression of Ets2, but not the Ets2TAD reverts morphological transformation. Cell morphology was visualized by phase-contrast microscopy. Actin filaments were visualized by immunofluorescence using rhodamine-conjugated phalloidin.



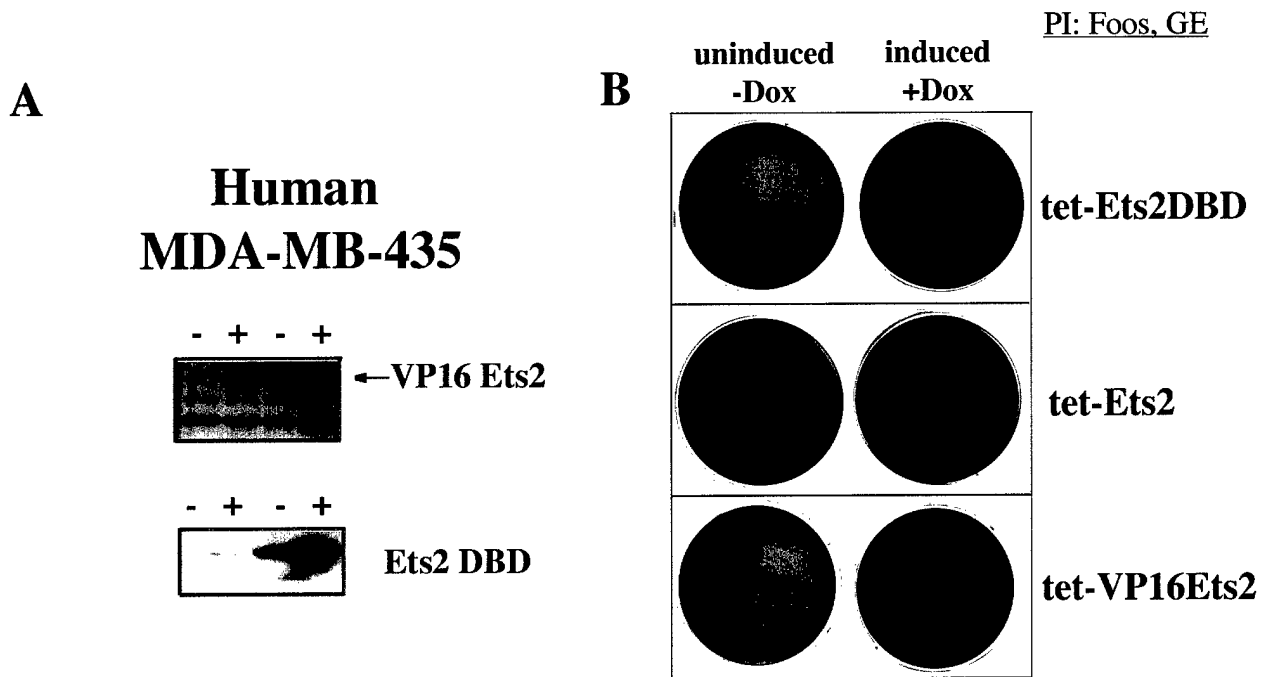
**Figure 3:** Soft agar and attached colony formation of DT-3T3 cells incubated with the MEK activation inhibitor PD098059



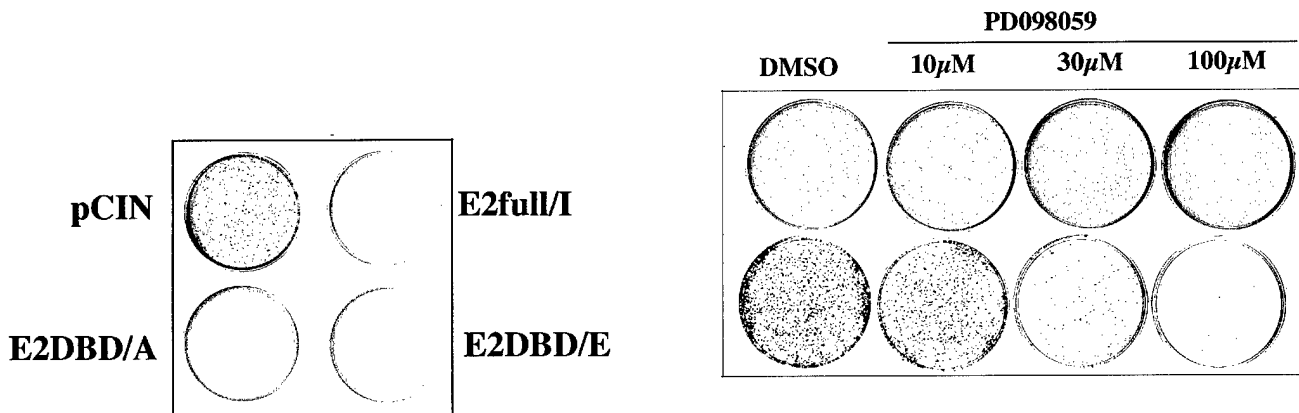
**Figure 4:**  
Expression levels of Ets2 constructs in stable MDA-MB-435 breast cancer lines

**Table 1: Tumor formation in nude mice**

Cell Line	Tumor Volume (mm <sup>3</sup> )			
	day 4	day 6	day 8	day 10
pCIN5	19±17	263±159	1,331±649	2,816 ±1,272
full#5	4±7	51±39	390±246	1,223 ±661
full#6	8±16	103±62	599±379	1,467 ±949
DBD#10	16±11	147±98	479±228	1,736 ±1,138
TAD#53	8±16	49±51	357±277	1,618 ±1,004
VP16full#1	22±13	76±62	630±516	1,553 ±973
VP16full#7	7±8	93±87	255±245	1,197 ±1,056

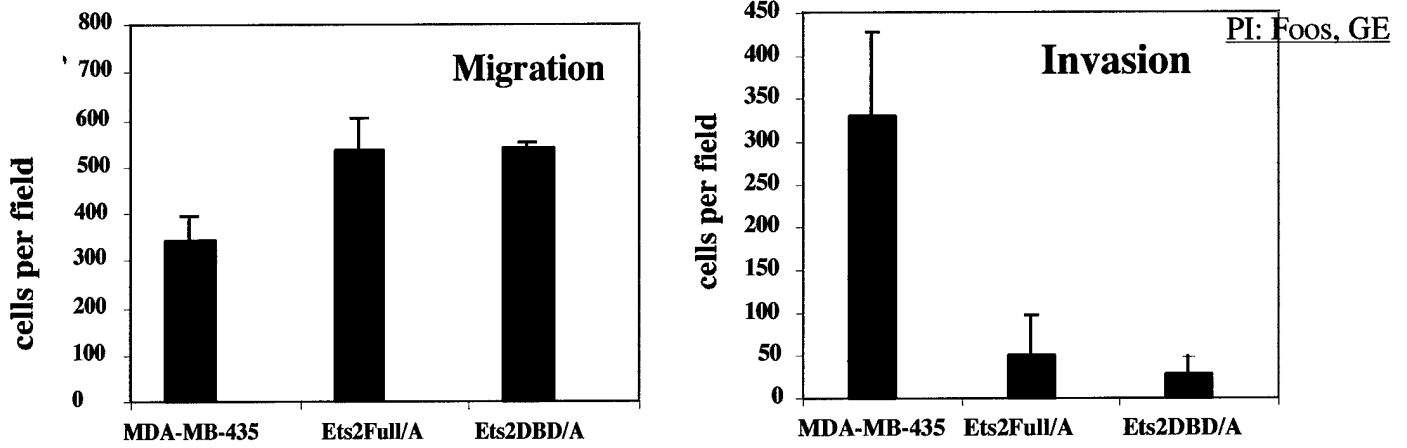


**Figure 5: Induction of the dominant inhibitory Ets2 construct or the activating constructs Ets2 or VP16Ets2 clearly leads to loss of anchorage-independent growth in soft agar. A) Western blot of inducible NIH 3T3 cells or MDA-MB-435 cells that were generated using the Clontech tet-on system. Cells were stimulated with Doxycycline overnight. B) Soft agar assays of MDA-MB-435 cells containing inducible Ets2 proteins.**

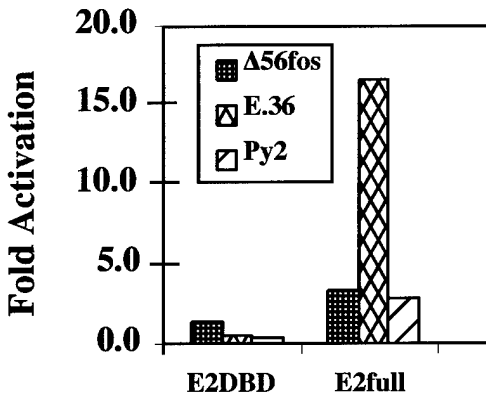


**Figure 6: Soft agar colony formation of individual stable MDA-MB-435 clones**

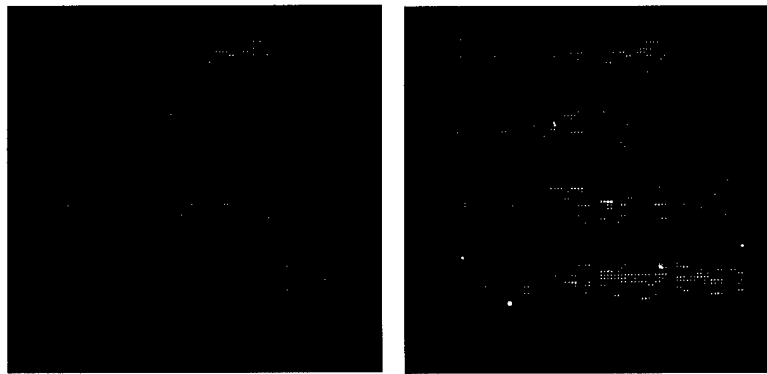
**Figure 7: Soft agar and attached growth of MDA-MB-435 cells incubated with PD098059**



**Figure 8. Effects of Ets2 or Ets2DBD on motility and invasion of MDA-MB-435 cells**  
 (A) Motility assay of the indicated stable clones, measuring the ability of cells to traverse uncoated filter inserts in 24 hours. The migration rate of the MDA-MB-435 control cell line and the indicated stable cell lines are shown. Values shown are the mean of triplicates. (b) *In vitro* invasion assays of the indicated stable MDA-MB-435 clones were performed using invasion chambers coated with Matrigel. The invasion rate of represents the average of triplicates .



**Figure 9: Ets-dependent transcription in MDA-MB-435 cells.** MDA-MB-435 mammary tumor cell lines were transfected with either a minimal promoter-containing  $\Delta 56$ Fos-Luc reporter, or this reporter with multiple Ets2 binding sites (E.36) or multiple Ets-AP-1 elements (Py2). Also included was either pCIN4 expression vector, or this vector expressing Ets2DBD or full-length Ets2. Fold activation is the activation of the reporter gene by Ets2 or Ets2DBD compared to pCIN.



**Figure 10: cDNA array to compare the cDNA expression pattern of parental MDA-MB-435 cells (left) to MDA-MB-435 cells overexpressing Ets2DBD (right)**

## **KEY RESEARCH ACCOMPLISHMENTS**

- (A) Stable expression of different activating or dominant inhibitory Ets2 constructs leads to loss of anchorage independent growth of Ras-transformed NIH 3T3 (DT-3T3) cells and of a human breast cancer cell line MDA-MB-435.
- (B) The reversion activity of the introduced Ets2 constructs correlate with their expression level in the individual stable clones in both of the cell types.
- (C) Overexpression of full-length Ets2, the Ets2DBD but not Ets2TAD leads to morphological reversion of DT-3T3 cells and stress fiber reorganization.
- (D) The Ets2 (thr72) residue is not required for the reversion activity in DT-3T3 cells.
- (E) Ets2 constructs act downstream of MAP kinase activation.
- (F) PD098059, a MAPK inhibitor has no effect on the reversion of the transformed phenotype of DT-3T3 cell. In contrast, even very low amounts of this inhibitor abolishes soft agar and attached growth of MDA-MB-435 cells.
- (G) Overexpression of Ets2, VP16Ets2 or Ets2DBD leads to a substantial delay in tumor formation *in vivo*.
- (H) The *in vitro* invasiveness of MDA-MB-435 mammary tumor cells, but not their motility, is strongly reduced by expression of either Ets2 or just the Ets2DBD.
- (I) Analysis of changes in gene expression in MDA-MB-435 cells which lost their anchorage-independence and *in vitro* invasiveness upon expression of Ets2 constructs has identified changes of potential biological significance, including altered expression of matrix metalloproteinase components and of a cell cycle inhibitory protein.

## **REPORTABLE OUTCOMES**

### **Publications**

Foos, G., Galang, C.K., Zheng, C.-F., and Hauser, C.A. (2001) Ras signaling to transcription activation: analysis with GAL4 fusion proteins. *Methods Enzymol.* 333 (in press, for Mar. 2001).

Foos, G., and Hauser, C.A. (2000) Altered Ets transcription factor activity in prostate tumor cells inhibits anchorage-independent growth, survival, and invasiveness. *Oncogene* 19 (48):5507-5516

Foos, G., Garcia-Ramirez JJ., Galang CK., and Hauser CA. (1998) Elevated expression of Ets2 or distinct portions of Ets2 can reverse Ras-mediated cellular transformation. *Journal of Biological Chemistry.* 273(30):18871-80

### **Meetings**

ALTERED ETS TRANSCRIPTION FACTOR ACTIVITY IN PROSTATE AND BREAST TUMOR CELL LINES CAN BLOCK ANCHORAGE -INDEPENDENT GROWTH. Gabriele Foos, Christina K. Galang, and Craig A. Hauser. *Oncogenes and Growth Control*, The Salk Institute, La Jolla, California, August 18-22, 1999

**ALTERED ETS ACTIVITY IN PROSTATE OR BREAST TUMOR CELL LINES CAN BLOCK ANCHORAGE-INDEPENDENT GROWTH AND INVASIVENESS.**

Foos, G., Galang, C.K., and Hauser, C.A.

Sixteenth Annual Meeting On Oncogenes, The Salk Institute, La Jolla, (2000)

**ROLE OF ETS2 IN CELULAR TRANSFORMATION IN A MODEL CELL LINE AND HUMAN BREAST CANCER CELL LINE**

Gabriele E. Foos and Craig A. Hauser

Era Of Hope Meeting, Atlanta, Georgia, June 8-12, 2000

**ALTERED ETS ACTIVITY IN PROSTATE AND BREAST TUMOR CELL LINES CAN BLOCK ANCHORAGE -INDEPENDENT GROWTH.**

Gabriele Foos, Christina K. Galang, and Craig A. Hauser.

Keystone Symposia "Advances in Human Breast and Prostate Cancer (E1)", Lake Tahoe, Incline Village, Nevada, March 19 - March 24, 2000

**SUMMARY AND CONCLUSIONS**

During the funding period I achieved considerable progress in all three objectives. My initial analysis of analyzing the effect of overexpressing dominant inhibitory or activating Ets2 constructs in Ras-transformed NIH-3T3 model cells turned out to be much more time consuming than initially anticipated. However, many of the findings in this model system subsequently were found to also apply to breast tumor cell lines. I found that overexpression of either activating or dominant inhibitory mutants of Ets2 are both able to reverse the transformed phenotype of the Ras-transformed murine cell lines. The parameters tested included anchorage-independent growth in soft agar, reorganization of stress fibers, reduced saturation densities, and delayed tumor formation in nude mice. In addition, I tested the effect of overexpressing a more specific inhibitor, the Ets2TAD, that does not bind DNA. This inhibitor had more distinct effects on the transformed phenotype of the DT-3T3 cells. Overexpression lead to loss of anchorage independent growth in soft agar, but in contrast to full-length Ets2 or Ets2DBD, did not influence morphology and stress fiber formation. These data suggest, that the function of Ets2 on anchorage independent growth and cell morphology are separable. The phosphorylation site thr72, which we found is essential for Ras-mediated increase in Ets2 transactivation activity (4,18,22) was not essential for the reversion activity of Ets2 in the assays performed. Overall, the results of my published studies with the Ras transformed murine cells (19) yielded several new insights into the role of Ets transcription factors in cellular transformation.

To test the effect of the dominant inhibitory or activating Ets2 constructs on human breast tumor cell lines, I established MDA-MB-435 cell lines overexpressing Ets2 or Ets2DBD. In these breast tumor cell lines, moderate overexpression of Ets2 led to reversion, but high level Ets2 expression appeared to block cell growth or survival. In earlier studies it had been hypothesized that the downregulation of Ets dependent transcription by overexpressing dominant inhibitory mutants of Ets block transcription of these genes that are responsible for the transformation status of these cells (20). It is therefore somewhat unexpected that an activating construct like full-length Ets2 or VP16 Ets2 showed strong reversion activity. In DT-3T3 cells, the VP16Ets2 construct showed the strongest reversion potential *in vitro* and *in vivo*. Because I was not able to establish MDA-MB-435 cells stably overexpressing VP16Ets2, I generated a MDA-MB-435 cell line that carried an inducible VP16Ets2 protein. I tested this line, together with MDA-MB-435 carrying inducible full-length Ets2 or Ets2DBD in soft agar assays. All the cell lines tested, lost their ability to grow in soft agar upon induction of the various Ets2

constructs, indicating that either activation or inhibition of Ets-dependent gene expression could inhibit anchorage-independent growth.

Overexpression of either full-length Ets2 or Ets2DBD in MDA-MB-435 cells also had profound effects on their migration and invasion behavior. Expression of either full-length Ets2 or Ets2DBD lead to an increase of motility of the MDA-MB-435 cells. In contrast, overexpression of either protein lead to a drastic decrease of invasion. These quite dramatic data of altered growth regulation and invasiveness led me to focus on the cellular targets of altered Ets function. Changes in potential direct target genes consistent with altered growth (e.g. p21<sup>waf/cip</sup>) and invasiveness (e.g. MMP3, TIMP1) were identified, and will form the basis for future mechanistic analysis of Ets target genes in these processes.

Overall, I have used the Ets2 constructs as a tool to analyze and characterize the role of Ets proteins in cellular transformation. These studies show, that altering Ets activity by inhibiting or activating Ets-dependent transcription can reverse Ras-mediated cellular transformation in fibroblasts. In addition, I found that the transformed behavior of the human breast cancer cell line MDA-MB-435 is similarly dependent on the balance of Ets factors in these cells. Finally, this analysis has lead to the identification of some potential important downstream targets of Ets signaling in breast cancer, which may contribute to finding more specific therapeutic approaches in treating breast cancers.

## REFERENCES

1. M. A. Price, A. E. Rogers, R. Treisman, *EMBO J.* **14**, 2589 (1995).
2. C. K. Galang, C. J. Der, C. A. Hauser, *Oncogene* **9**, 2913 (1994).
3. B. -S. Yang, C. A. Hauser, G. Henkel, M. S. Colman, C. Van Beveren, et al, *Molec. Cell. Biol.* **16**, 538 (1996).
4. C. K. Galang, J. J. García-Ramírez, P. A. Solski, J. K. Westwick, C. J. Der, et al, *J. Biol. Chem.* **271**, 7992 (1996).
5. A. Giovane, A. Pintzas, S. M. Maira, P. Sobieszczuk, B. Wasylyk, *Genes. Dev.* **8**, 1502 (1994).
6. D. N. Sgouras, M. A. Athanasiou, G. J. Beal, Jr., R. J. Fisher, D. G. Blair, et al, *EMBO J.* **14**, 4781 (1995).
7. J. M. Bradburay, H. Sykes, P. A. W. Edwards, *Int. J. Cancer* **48**, 908 (1991).
8. C. Wasylyk, S. M. Maira, P. Sobieszczuk, B. Wasylyk, *Oncogene.* **9**, 3665 (1994).
9. T. K. Chen, L. M. Smith, D. K. Gebhardt, M. J. Birrer, P. H. Brown, *Mol. Carcinog.* **15**, 215 (1996).
10. H. Suzuki, V. Romano-Spica, T. S. Papas, N. K. Bhat, *Proc. Natl. Acad. Sci. U. S. A.* **92**, 4442 (1995).
11. E. Sapi, M. B. Flick, S. Rodov, B. M. Kacinski, *Cancer Research* **58**, 1027 (1998).
12. A. F. Chambers, A. B. Tuck, *Critic. Rev. Oncogen.* **4**, 95 (1993).
13. E. C. Kohn, L. A. Liotta, *Cancer Res.* **55**, 1856 (1995).

14. B. W. Ennis, L. M. Matrisian, *J. Neurooncol.* **18**, 105 (1993).
15. R. Pankov, A. Umezawa, R. Maki, C. J. Der, C. A. Hauser, et al, *Proc. Natl. Acad. Sci. U. S. A.* **91**, 873 (1994).
16. M. Noda, Z. Selinger, E. M. Scolnick, R. H. Bassin, *Proc. Natl. Acad. Sci. U. S. A.* **80**, 5602 (1983).
17. S. Rees, J. Coote, J. Stables, S. Goodson, S. Harris, et al, *Biotechniques.* **20**, 102 (1996).
18. B. S. Yang, C. A. Hauser, G. Henkel, M. S. Colman, C. Van Beveren, et al, *Mol. Cell Biol.* **16**, 538 (1996).
19. Foos, G., Garcia-Ramirez JJ., Galang CK., and Hauser CA., *J. Biol Chem.* **273**, 18871 (1998).
20. S. J. Langer, D. M. Bortner, M. F. Roussel, C. J. Sherr, M. C. Ostrowski, *Molec. Cell Biol.* **12**, 5355 (1992).
21. Foos, G., and Hauser, C.A. *Oncogene* **19**, 5507 (2000)
22. Foos, G., Galang, C.K., Zheng, C.-F., and Hauser, C.A. *Methods Enzymol.* **333** (in press, for Mar. 2001).

*In memory of my mother, who died of breast cancer October 3rd, 2000.*

## Elevated Expression of Ets2 or Distinct Portions of Ets2 Can Reverse Ras-mediated Cellular Transformation\*

(Received for publication, January 26, 1998, and in revised form, May 12, 1998)

Gabriele Foos, José Javier García-Ramírez, Christina K. Galang, and Craig A. Hauser‡

From the La Jolla Cancer Research Center, The Burnham Institute, La Jolla, California 92037

Ets transcription factors are important downstream targets of oncogenic Ras. The transcriptional activity of several Ets family members is regulated by Ras, and interfering with Ets-dependent transcription by expression of just the Ets2 DNA binding domain can inhibit or reverse Ras-mediated cellular transformation. To better understand the role of Ets proteins in Ras transformation, we have now analyzed the effects of stably expressing a variety of Ets2 constructs in Ras-transformed NIH3T3 (DT) cells. Expression of only the Ets2 transactivation domains, which also inhibits Ras or Neu/ErbB-2-mediated activation of Ets-dependent transcription, strongly inhibited anchorage-independent growth, but did not revert the transformed DT cell morphology. Unexpectedly, high expression of full-length Ets2, a transcriptional activator, broadly reversed the transformed properties of DT cells, including anchorage-independent growth, transformed morphology, and tumorigenicity, but did not impair attached cell growth. Increasing full-length Ets2 transcriptional activity by fusing it to the VP16 transactivation domain enhanced its ability to reverse DT cell transformation. Mutational analysis revealed that the mitogen-activated protein kinase phosphorylation site required for Ras-mediated activation, Ets2(T72), was not essential for Ets2 reversion activity. The distinct reversion activities of the highly expressed Ets2 transactivation domains or full-length Ets2, along with the specific reversion activity by Ets2 constructs that either inhibit or activate Ets-dependent transcription, suggests multiple roles for Ets factors in cellular transformation. These results indicate that several distinct approaches for modulating Ets activity may be useful for intervention in human cancers.

Ets2 is one of the founding members of the Ets transcription factor family, which are characterized by a conserved DNA binding motif called the ETS domain (1). There are now over 30 known members of the Ets family, found in species ranging from humans to *Caenorhabditis elegans* (2). The mouse and human Ets2 genes were initially identified through extended similarity to chicken *v-ets* (3, 4). *c-ets2* gene is ubiquitously expressed in mouse embryonic and adult tissues (5). One evolutionarily conserved role of many Ets proteins is their function as downstream mediators of the Ras signal transduction path-

way. The *Drosophila* Ets proteins Pointed P2, a transcriptional activator, and Yan, a transcriptional repressor, are targets of Ras signaling (6-8). Ets2 and several other mammalian Ets proteins contain a region of homology with *Drosophila* Pointed P2 distinct from the Ets domain, called the Pointed domain (9). Ras-mediated signaling through Pointed P2 requires a threonine residue within a MAP<sup>1</sup> kinase recognition site in the Pointed domain (6, 7). A corresponding MAP kinase recognition sequence is also found in the Ets2 pointed domain. We previously showed that phosphorylation of this corresponding Ets2 (T72) residue is essential for Ras- or Neu/ErbB-2-mediated activation of Ets2 transactivation activity (10, 11), and that Ras signaling to Ets2 takes place through the Ras/Raf/MEK/MAPK pathway (12).

Several lines of evidence suggest that not only are Ets proteins targets of Ras signaling, but that Ets factors play an important role in mediating cellular transformation. Initial characterization of several oncogene-responsive promoter elements revealed that adjacent Ets and AP-1 binding sites mediate their oncogene responsiveness, and that both the Ets and AP-1 binding sites are essential for induction by the activated non-nuclear oncogenes (13, 14). Similar elements have since been found in the promoters of many genes, and where it has been tested, Ets2 can cooperate with AP-1 family members and Ras to activate their transcription. The products of these Ras-induced genes have a wide spectrum of functions, including roles in cellular metabolism, growth control, and metastasis (15-17). There is a good correlation between the ability of various non-nuclear oncogenes to activate the transcription of reporter genes containing adjacent Ets and AP-1 binding sites, and their ability to transform rodent fibroblasts (2, 14, 15, 18). Although Ets binding sites in oncogene-responsive promoter elements are often found adjacent to binding sites for the Ras activated AP-1 family of transcription factors, Ets2 is a distinct target of Ras signaling. We previously showed that two adjacent Ets2 consensus binding sites, similar to those found in the stromelysin promoter (13), are sufficient to confer both Ets2 and Ras responsiveness to a minimal promoter (10, 19). Despite initial reports indicating that high level expression of Ets1 or Ets2 in NIH3T3 cells could give rise to infrequent transformed colonies (20, 21), there has been little subsequent evidence to suggest that simply increasing the amount of Ets1 or Ets2 proteins is sufficient for cellular transformation. However, the necessary role of Ets proteins in fibroblast transformation has been revealed by inhibition experiments, where expression of the Ets2 DNA binding domain alone was found to inhibit oncogenic Ras- or Neu-mediated cellular transformation (11, 22). In addition, expression of the Ets1, Ets2, or PU.1 DNA binding

\* This work was supported by National Institutes of Health Grant CA63130 (to C. A. H.) and postdoctoral fellowships (to G. F. and J. G.-R.) from the Deutsche Forschungsgemeinschaft and the Spanish Ministry of Education, respectively. The costs of publication of this article were defrayed in part by the payment of page charges. This article must therefore be hereby marked "advertisement" in accordance with 18 U.S.C. Section 1734 solely to indicate this fact.

‡ To whom correspondence should be addressed: La Jolla Cancer Research Center, The Burnham Institute, 10901 N. Torrey Pines Rd., La Jolla, CA 92037. Tel.: 619-646-3119; Fax: 619-646-3192; E-mail: chauser@jcrf.edu.

<sup>1</sup> The abbreviations used are: MAP, mitogen-activated protein; MAPK, mitogen-activated protein kinase; MEK, MAPK kinase; TAD, transactivation domains; DBD, DNA binding domain; ERK, extracellular signal-regulated kinase; PBS, phosphate-buffered saline; IRES, internal ribosome entry site.

domains was shown to reverse the transformed phenotype of stably Ras-transformed fibroblasts (23). Importantly, the expression of these presumptive dominant inhibitory Ets mutants did not impair normal cell growth in these studies, suggesting that altering Ets activity may be an approach to specifically reverse the transformed phenotype.

Because Ets family proteins bind to similar DNA sequences centered about a conserved GGAA/T core (2), it is likely that high level expression of the ETS domain from Ets2 inhibits the binding and function of many members of the Ets family. This idea was supported by the finding that expression of the ETS domain of either of two of the most divergent Ets family members, Ets1 or PU.1, could reverse Ras transformation (23). Thus, studies utilizing high expression of ETS domains do not identify which individual Ets family members are actually important in cellular transformation. In addition, although most Ets factors are associated with transcriptional activation (2), several widely expressed Ets proteins including ERF, SAP2/NET, and TEL have been reported to be negative regulators of transcription (24–26). Thus, it is possible that the dominant inhibitory mutants do not inhibit transformation by blocking Ets-dependent transcriptional activation, but instead may be overcoming transcription inhibition by Ets family repressors.

To further analyze the role of Ets proteins in cellular transformation, we have generated a number of Ets2 expression constructs, which can inhibit or activate Ets-dependent transcription, and tested their ability to reverse several criteria of the transformed phenotype when stably expressed in Ras-transformed mouse fibroblasts. To more specifically target Ets2, which is expressed in the Ras-transformed DT cells used in this analysis (27), we have used an expression construct for the Ets2 transactivation domains without the ETS domain. We previously showed that expression of the Ets2 transactivation domains inhibits activation of Ets-dependent transcription by either oncogenic Ras or Neu/ErbB-2 (11). This Ets2 construct contains extensive homology only with Ets1, as well as more limited homology with other members of the Pointed domain subfamily of Ets proteins. We show here that expression of either the Ets2 DNA binding domain or the Ets2 transactivation domains can inhibit Ras-mediated anchorage-independent growth, but these two constructs do not behave identically in reversing other features of the transformed phenotype. Somewhat unexpectedly, we also found that elevated expression of full-length Ets2 phenotypically reverts DT cell transformation, and that expression of a construct that artificially increases the transactivation activity of full-length Ets2 is even more efficient in reversing the Ras-transformed phenotype.

#### MATERIALS AND METHODS

**Cell Growth and Selection**—The DT cell line is a Ras-transformed NIH 3T3 cell line originally transformed by integration of two separate copies of the Kirsten murine sarcoma virus carrying the v-Ki-Ras gene (28). The DT cells were kindly provided by Dr. Y. S. Cho-Chung (National Cancer Institute, National Institutes of Health). DT cells were grown in DMEM supplemented with 10% fetal calf serum, and NIH 3T3 cells were grown in DMEM supplemented with 10% calf serum. Stable DT cell lines were generated by transfection using the calcium phosphate precipitation method we previously described (56), except that, for a 60-mm dish, 3  $\mu$ g of pCIN-derived expression plasmid DNA and 12  $\mu$ g of high molecular weight herring sperm DNA were used. Stable colonies were selected 3 days after transfection using medium containing 400  $\mu$ g/ml active G418 (Calbiochem). Multiple isolated DT cell clones derived from each expression plasmid were randomly picked, then expanded and passaged in the presence of 400  $\mu$ g/ml G418 for subsequent analysis.

**Plasmids**—The pCIN4 mammalian expression vector used for all of the constructs is a derivative of the pCIN plasmid (30), and was kindly provided by Steve Rees (Glaxo Wellcome). This vector is based on pCDNA3 (Invitrogen) and utilizes the CMV enhancer/promoter to ex-

press an inserted coding sequence, which is linked by a viral internal ribosome entry site (IRES) to the neomycin phosphotransferase gene. We have previously described the construction of pCDNA3-based mouse Ets2 expression constructs (FN-Ets2) for full-length wild type Ets2(T72), Ets2(A72), Ets2TAD, Ets2DBD, and the empty FNpCDNA3 (11). These constructs all include the FN sequence, a 20-residue N-terminal sequence containing the FLAG epitope tag followed by an SV40 nuclear localization signal. The FN sequence was found not to alter the activity of full-length Ets2 (11). To generate the pCIN-Ets2 expression constructs, we exchanged the CMV enhancer/promoter and FN-Ets2 coding sequences contained in an *NruI-NotI* fragment of the FN Ets2 constructs, with the *NruI-NotI* fragment containing the pCIN4 CMV enhancer/promoter up to the *NotI* site in the pCIN4 polylinker. The resulting pCIN-Ets2 constructs (from 5' to 3') contained a consensus translational start, the FLAG and SV40 NLS sequences fused to the Ets2 coding sequences, a splice site, an IRES, the neomycin phosphotransferase gene, and a poly(A) signal. The VP-16-containing constructs were generated using standard polymerase chain reaction methods to insert VP16 residues 410–479 in-frame as a *BamHI-BglII* fragment into the *BamHI* site at the junction of the FLAG/NLS and the Ets2 coding sequences in FN-Ets2, or into the *BamHI* site of empty FNpCDNA3 vector. These sequences were then transferred to pCIN4 as described above.

The reporter plasmid  $\Delta$ 56FosDE-luc is the same as the modified minimal *fos* promoter-containing  $\Delta$ 56FosDE-CAT reporter we previously described (19), except that the coding sequence of CAT was replaced by that of luciferase. The CAT coding sequence of  $\Delta$ 56 FosDE-CAT was removed by digestion with *NaeI+EcoRI* and replaced with a *HindIII-SmaI* fragment containing the luciferase coding sequence from LA5'pJD204 (57). Both the vector (*EcoRI*) and insert (*HindIII*) sites were blunted prior to ligation. Similarly, the E.18-luc and Py<sub>2</sub>-luc reporters were constructed as described previously (10), except that the E.18pal oligonucleotide (two adjacent Ets2 binding sites in inverted orientation) or two copies of the Py oligonucleotide (the adjacent Ets and AP-1 binding sites from the polyoma enhancer) were inserted into  $\Delta$ 56FosDE-luc instead of  $\Delta$ 56FosDE-CAT.

**Soft Agar/Attached Growth Assay**—Soft agar assays were essentially performed as described previously (31). Either 500 or 1000 cells were plated in 60-mm dishes in 1.5 ml of medium containing 0.33% agar, which was overlaid onto 7 ml of solidified medium containing 0.5% agar. The medium used for soft agar assays was DMEM + 10% fetal calf serum, and did not contain G418. The soft agar plates were fed with 0.5 ml of medium every 5–7 days, and after 14 days, the cells were stained overnight (at 37° and 5% CO<sub>2</sub>) with the vital dye *p*-iodonitroretazolium violet, and then counted. The *p*-iodonitroretazolium violet (Sigma) was prepared as a 10 mg/ml stock solution in ethanol, then diluted with PBS to 1 mg/ml, and 0.5 ml of this diluted solution was added to each dish. In parallel to each soft agar assay, an attached growth assay was performed, where 100 cells from the same cell dilutions were plated on standard tissue culture dishes and grown for 7 days. The resulting attached colonies were stained with crystal violet and counted. The number of soft agar colonies for each cell line was then normalized by multiplying by the ratio (attached colonies from DT cells)/(attached colonies from the cell line) in the same experiment.

**Actin Staining and Immunoblots**—Actin filaments were visualized by growing the cells on glass coverslips and staining the cells with rhodamine-conjugated phalloidin (Molecular Probes, Inc.) as recommended by the manufacturer. The FLAG epitope-tagged Ets2 proteins and the Ras proteins were detected in immunoblots using the anti-FLAG M5 monoclonal antibody (Eastman Kodak Co.), and the pan-Ras AB-4 (Calbiochem), respectively. Primary antibody binding was visualized using the Phototope-HRP Western blot detection kit (New England BioLabs) and BioMax film (Eastman Kodak Co.).

**Reporter Gene Assays**—Transfection and reporter gene assays were performed as we described previously (58). In brief, 12-well dishes of 50% confluent DT cells were transfected by the calcium phosphate method, using 0.5  $\mu$ g of reporter plasmid, 0.25  $\mu$ g of pCIN4-derived Ets2 expression constructs, and 5  $\mu$ g of sheared herring testis carrier DNA for each well. Sixteen hours following transfection, the growth medium was replaced with medium containing 0.5% calf serum, and the cells were incubated for an additional 28 h before harvest. Luciferase activity was quantitated using a Berthold Microlumet LB 96P luminometer. Transfection efficiency and nonspecific effects were controlled as we described (58), by analyzing multiple replicates (standard deviations are shown), and by demonstrating lack of effect in parallel on  $\Delta$ 56FosDE-luc, a non-Ets-dependent reporter.

**MAPK and RNase Protection Assays**—The immune complex MAP kinase assays were performed essentially as described (59), using 50  $\mu$ g

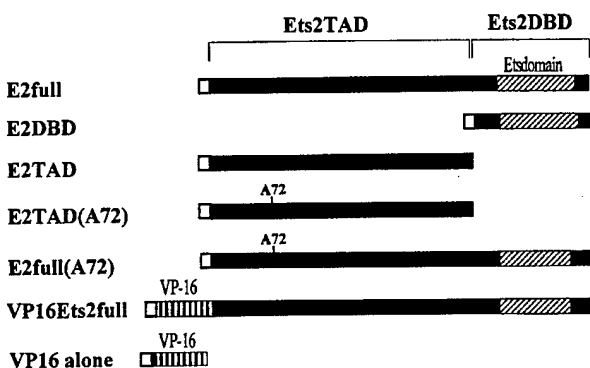


FIG. 1. Schematic diagram of Ets2 coding sequences in the expression constructs used to generate stable DT cell lines. The ETS domain is indicated by cross-hatches, and the remaining Ets2 coding sequences by black bar. The N-terminal FLAG epitope tag and SV40 nuclear localization signal are shown by the white box. Brackets denote the Ets2 transactivation domains (Ets2TAD) and DNA binding domain (Ets2DBD). Where present, the Ets2(T72A) mutation is indicated, and the added VP16 transactivation domain is indicated by vertical stripes.

of total cell extract protein and the ERK1 C-16-G antibody (Santa Cruz Biotechnology). The precipitated MAPK bound to this antibody and protein G-Sepharose (Amersham Pharmacia Biotech) was incubated with buffer containing [ $\gamma$ - $^{32}$ P]ATP and 10  $\mu$ g of myelin basic protein (Sigma). The entire reaction mix was then subjected to SDS-polyacrylamide gel electrophoresis, and radiolabeled myelin basic protein was detected by autoradiography and quantitated using a phosphorimager (Bio-Rad). RNase protection assays were performed as described (60) and a probe for the L32 ribosomal protein L32 mRNA was included as an internal standard as described (61). The Ets2 RNase protection probe was generated by SP6 RNA polymerase transcription of the *Nde*I-cut FN-Ets2(1-100) construct, which contains the FLAG/NLS coding sequences fused to the Ets2 coding sequence from amino acids 1-100. This 800-base probe protects 300 bases of the endogenous Ets2 message and 416 bases of the introduced FN-Ets2 message.

**Tumorigenicity Assay**—Stable cell lines grown under G418 selection were trypsinized, washed with PBS, and counted using a hemocytometer. Then,  $5 \times 10^5$  cells in 0.1 ml of PBS were subcutaneously injected into both the right and left dorsal flanks of 4-week-old nude mice. At 2-day intervals, the tumors were measured externally by caliper, and the average of the tumor length and width was estimated to be the tumor diameter,  $d$ . No tumors were detected on day 2. The approximate tumor volume was calculated using the formula  $V = (\pi/6)(d)^3$ . For each cell line, 6-8 tumors were generated (in both flanks of 3-4 mice) and measured over the indicated time. The average tumor volume (in  $\text{mm}^3$ ) was then calculated. The statistical analysis of tumor growth was performed by comparing the individual volumes of the 6-8 tumors derived from each cell line relative to that of tumors from DT cells containing the empty expression vector pCIN#5, using a two-tailed, unpaired  $t$  test.

## RESULTS

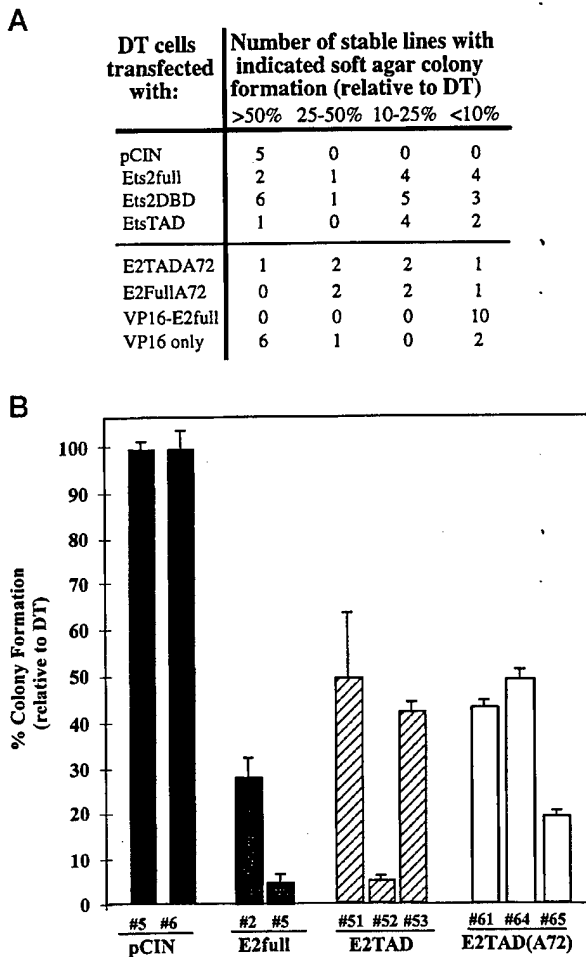
**Generation of Stable Ets2-expressing DT Cell Lines**—The findings that high expression of the Ets2 DNA binding domain can block oncogene-mediated cellular transformation (11, 22) and can also reverse the transformed phenotype of Ras-transformed fibroblasts (23) indicate that Ets protein function is important in cellular transformation. To better characterize the role of Ets proteins in Ras-mediated cellular transformation, a variety of Ets2 expression constructs were generated, including expression constructs for full-length Ets2, the Ets2 transactivation domains (Ets2TAD), and the Ets2 DNA binding domain (Ets2DBD). A schematic diagram of these constructs is shown in Fig. 1. The ability of these Ets2 expression constructs to reverse Ras-mediated transformation was analyzed in stable clones generated in the DT cell line, a v-Ki-Ras-transformed derivative of mouse NIH3T3 fibroblasts (28). This doubly transformed (DT) cell line is well suited for reversion

analysis due to its low rate of spontaneous reversion (29). To improve the frequency of individual stable drug-resistant colonies expressing high levels of the Ets2 constructs, we used the pCIN4 vector (30). This plasmid contains an IRES and generates a bicistronic message with the inserted upstream (Ets2) coding sequences at the 5' side of the mRNA linked by the IRES to the 3' neomycin phosphotransferase gene. Because both genes are present on a single mRNA, any G418-resistant colonies derived with this vector should express moderate to high levels of the upstream Ets2 coding sequences. Indeed, as was reported for the serotonin receptor (30), we found a dramatic increase in the number of pCIN-derived stable colonies detectably expressing Ets2 constructs, relative to that seen using the parental pcDNA3 vector (data not shown), and nearly all of the cell lines had clearly visible expression of the introduced gene products (see below). This high frequency of cell lines expressing the introduced Ets2 constructs allowed us to directly analyze the phenotype of stable clones, without preselecting for adherent revertants as was described previously for the Ets2 DNA binding domain (23). For the analysis described below, multiple individual stable DT cell clones generated with each Ets2 expression construct or control plasmid were randomly picked, expanded, and assayed for alterations in the transformed phenotype and for expression of the introduced gene product.

**Expression of Full-length Ets2, Ets2TAD, or Ets2DBD Inhibits Anchorage-independent Growth of DT Cells**—The ability of fibroblasts to grow in an anchorage-independent manner is a hallmark of cellular transformation, and is the best *in vitro* assay for predicting malignant tumorigenicity *in vivo* (31). NIH3T3 cells are unable to grow in soft agar, whereas the Ras-transformed DT-3T3 cells plate quite efficiently in soft agar. This assay was used to analyze the capacity for anchorage-independent growth of individual DT cell clones transfected with either empty pCIN vector or the pCIN-Ets2 expression constructs schematically shown in Fig. 1. The results of this analysis are shown in Fig. 2A. None of the five independent cell lines derived with the empty pCIN expression vector displayed significantly reduced growth in soft agar relative to the parental DT cells, but surprisingly, 7/11 of the cell lines derived with full-length Ets2 showed a greater than a 4-fold reduction in soft agar growth. This high frequency of reversion seen in randomly picked Ets2-expressing cell lines virtually excludes the possibility that a secondary mutation is required for reversion. The majority of clones derived with the Ets2TAD, which lacks the Ets2 DNA binding domain, also showed significantly reduced anchorage-independent growth. Finally, similar to a previous report (23), several Ets2DBD cell lines also showed significant reductions in anchorage-independent growth (Fig. 2A).

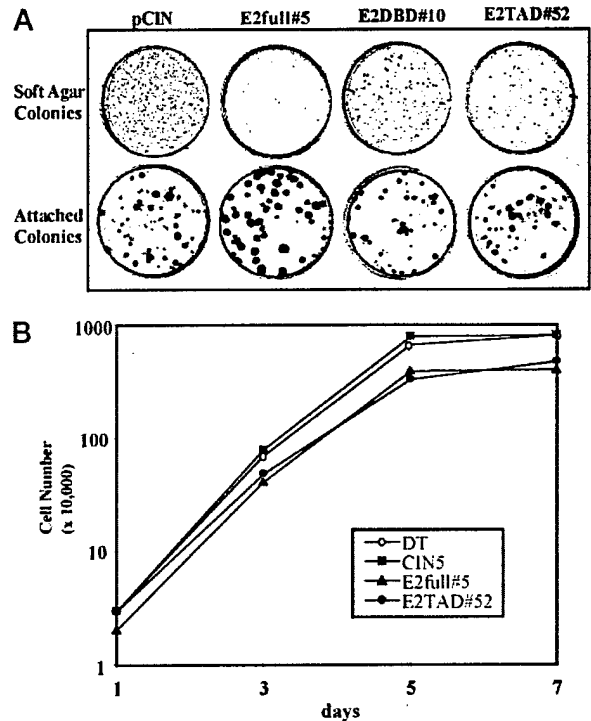
To examine the anchorage-independent growth of several individual clones in more detail, and to establish the reproducibility of the soft agar assay, several frozen cell lines were reestablished and reassayed for growth in soft agar. The small standard deviations of duplicate samples between at least two different plating experiments (Fig. 2B) shows that the soft agar plating assay was highly reproducible. In addition, these data show that anchorage-independent growth in some cell lines, such as Ets2full#2 or Ets2TAD#52, is reduced more than 10-fold.

**Ets2 Expression Constructs Do Not Inhibit Attached Cell Growth**—To determine that reduced soft agar growth reflected a specific loss of anchorage-independent growth and not impaired attached cell growth or errors in cell counting, cells from the same dilution used for the soft agar assay were plated in parallel onto normal tissue culture dishes. The results of a



**FIG. 2. Effects of Ets2 expression constructs on anchorage-independent growth.** Panel A, individual stable DT cell clones derived from transfection with the indicated expression constructs, were assayed for their ability to grow in soft agar. Growth in soft agar was expressed as percent of colony formation relative to the parental DT cell line, for which approximately 60% of the plated cells formed colonies. The distribution of individual clones that displayed the indicated ranges of relative growth in soft agar is shown. Soft agar assays were performed in triplicate, and parallel attached growth analysis showed reduced soft agar growth was not due to altered attached cell growth rates (see text). Panel B, analysis of individual stable clones. Percent of soft agar colony formation relative to DT cells was calculated by comparison to the growth of the DT cells in the same plating experiment. Data are averages of duplicate samples from at least two independent assays.

typical parallel soft agar and attached growth assay are shown in Fig. 3A, where the Ets2-expressing lines show a clear reduction in soft agar growth but not in attached growth. The number of attached colonies obtained in each assay was used to normalize the number of soft agar colonies (see "Materials and Methods"), but this normalization caused only minor changes in the results. Although no clear differences were seen in cell growth rate during expansion or attached colony growth of the various cell lines, the attached growth rates of representative cell lines were examined in more detail. We found that the growth rates of cell lines expressing full-length Ets2 or the Ets2 TAD were similar to that of pCIN only lines or the parental DT cells during exponential growth, but consistent with a more reverted phenotype, the cell lines generated with Ets2 expression constructs exhibited a reduced saturation density (Fig.



**FIG. 3. Anchorage-dependent growth is not inhibited by Ets2 constructs.** Panel A, parallel analysis of anchorage-dependent and -independent growth. The indicated cell lines were plated in soft agar (500 cells) or on normal tissue culture dishes (100 cells), and were incubated and stained as described under "Materials and Methods." Panel B, Ets2 expression reduces saturation density, but not cell growth rate. Cells were seeded on 60-mm dishes, and the average number of cells on duplicate plates was determined after the indicated number of days.

3B). Overall, analysis of attached colony growth and cell growth rates (Fig. 3, A and B, and data not shown) revealed that the cell lines expressing the Ets2 constructs were not impaired in attached cell growth. Together, the data in Figs. 2 and 3 show that expression of either full-length Ets2 or the Ets2 transactivation domains can strongly and specifically inhibit anchorage-independent growth of DT cells.

**Morphological Reversion of DT Cells by Expression of Full-length Ets2 or Ets2DBD, but Not Ets2TAD**—The cell morphology of stable cell lines found to exhibit significantly reduced anchorage-independent growth was examined using phase-contrast microscopy of live cells. Normal NIH3T3 cells exhibit a flat, non-refractile morphology, whereas the Ras-transformed DT cells containing empty pCIN expression vector are spindly and refractile (Fig. 4), as are the parental DT cells (data not shown). However, we found that all of the full-length Ets2 or the Ets2DBD DT cell lines which exhibited significantly reduced soft agar growth were flat and non-refractile. Interestingly, this apparent morphological reversion was not observed in any of the cell lines expressing the Ets2TAD, despite the fact that they showed reduced growth in soft agar. The morphology of representative cell lines is shown in Fig. 4. In addition, we analyzed the cytoskeletal organization of the various cell lines after staining with rhodamine-conjugated phalloidin. As previously observed, NIH3T3 cells contained well organized actin stress fibers, which are not present in Ras-transformed DT cells (Fig. 4). Similar to the changes in overall cell morphology, the actin stress fibers reappeared in DT cell lines expressing full-length Ets2 or the Ets2DBD, but not in cells expressing the Ets2TAD (Fig. 4). Thus, unlike expression of full-length Ets2 or

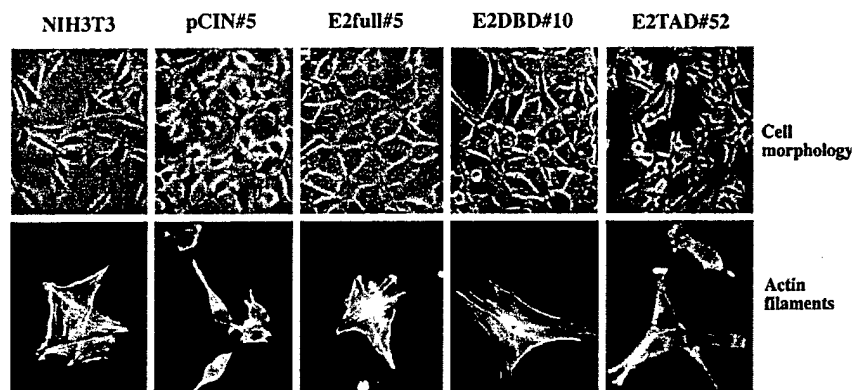


FIG. 4. Expression of Ets2, but not the Ets2TAD reverts morphological transformation. Cell morphology of NIH3T3 or representative stable DT cell lines expressing the indicated Ets2 constructs (or the empty vector pCIN) was visualized by phase-contrast microscopy. Actin filaments were visualized by immunofluorescence using rhodamine-conjugated phalloidin.

the Ets2DBD, expression of the Ets2 TAD is unable to cause reversion of cell morphology or actin filament reorganization in DT cells, indicating that there are differences in the targets of these Ets2 constructs.

**The Ets2 Thr-72 Residue Is Not Required for Reversion Activity**—We previously showed that phosphorylation of the Ets2(T72) residue is essential for the large Ras pathway-mediated increase in Ets2 transactivation activity, and that an Ets2(A72) mutant retained basal transcriptional activity, but lost Ras responsiveness (10, 11). To test the connection between Ras signaling to Ets2 and the ability of expressed Ets2 to revert transformation, we determined whether expression of Ets2TAD(A72) or full-length Ets2(A72) could reverse the anchorage-independent growth or transformed morphology of DT cells. Schematic diagrams of the pCIN expression constructs used for this analysis are shown in Fig. 1. As described above for the wild type Ets2 constructs, multiple independent cell lines were derived after transfecting these expression constructs into DT cells. The ability of individual stable cell lines to grow in soft agar is shown in Fig. 2A. Although introduction of the (A72) mutation caused a modest reduction in apparent reversion activity, both the full-length Ets2(A72) and the Ets2TAD(A72) constructs still clearly caused significant decreases in anchorage-independent growth. The soft agar growth analysis of three cell lines containing either the Ets2TAD(A72) (Fig. 2B) or the Ets2(A72) expression constructs (Fig. 5B) revealed an over 4-fold reduction in anchorage-independent growth, indicating that phosphorylation of Ets2(T72) was not essential for their reversion activity. As described above, parallel plating experiments on tissue culture dishes and growth rate analysis demonstrated that the reduced soft agar colony formation in these cell lines was not due to a reduced cell growth rate or altered plating efficiency (data not shown). Analysis of the effects of full-length Ets2(A72) or the Ets2TAD(A72) on cell morphology and actin stress fibers revealed that these Ala-72 constructs had the same effect as their wild type counterparts: the full-length Ets2(A72) cell lines appeared reverted, and the Ets2TAD(A72) cell lines did not (data not shown).

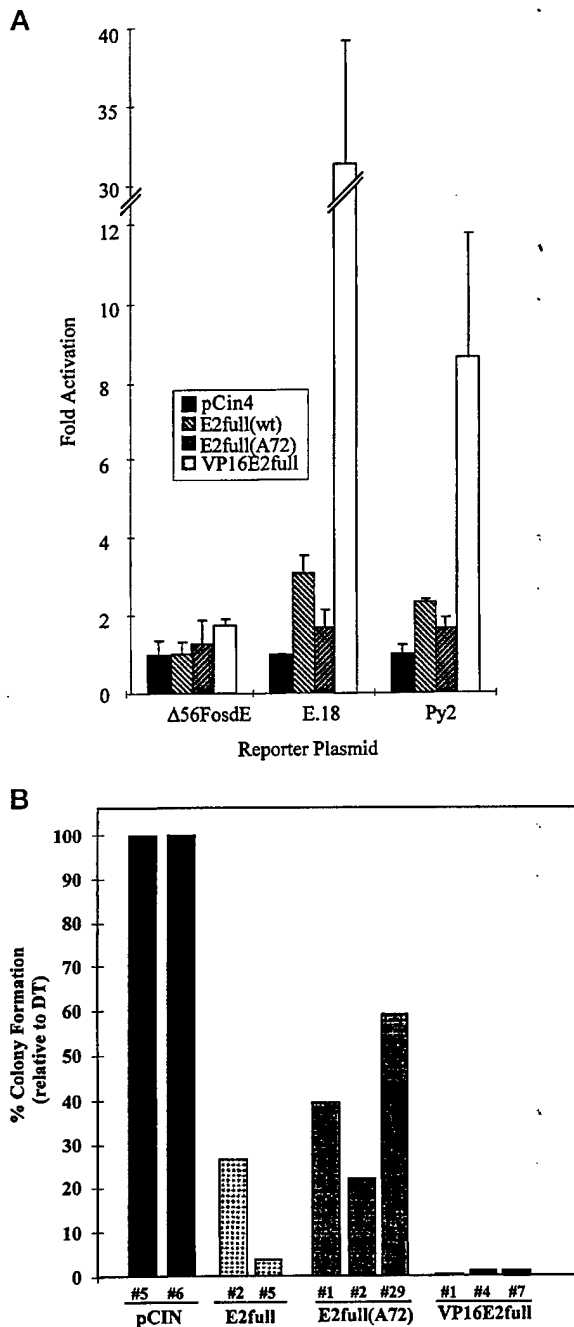
**Reversion Activity of Full-length Ets2 Constructs Correlates with their Transactivation Activity**—The surprising result that expression of full-length Ets2 could inhibit DT cell anchorage-independent growth and reverse-transformed cell morphology, and that the less transcriptionally active Ets2(A72) mutant was less efficient at reversion (Fig. 2A), suggested that the observed reversion was not simply due to inhibition of Ets-dependent transcription. To analyze the role of Ets2-mediated transcription activation in reversion activity, we generated a full-length Ets2 construct with increased transactivation activity. The powerful viral transcription activation domain from VP16 was fused to the N terminus of full-length Ets2. Cotrans-

fection of the resulting pCIN-VP16-Ets2 expression construct was found to transactivate the expression of the Ets-dependent reporter gene E.18pal by over 100-fold in NIH3T3 cells (data not shown), a substantial increase over the maximal 10-fold activation we observed with normal full-length Ets2 (10, 19). To confirm that full-length Ets2 and VP16Ets2 also activate Ets-dependent transcription in the context of the Ras-transformed DT cells, we assayed the effects of transiently cotransfecting the various Ets2 expression constructs with several reporter genes in DT cells. As previously reported (23), expression of the Ets2DBD inhibited Ets-dependent transcription (data not shown). In DT cells, the Ets2 expression constructs did not significantly alter expression of the minimal promoter-containing reporter  $\Delta$ 56FosdE (Fig. 5A). Although only a small amount of Ets-dependent reporter gene activation was seen with Ets2(A72), wild type Ets2 expression activated the expression of the E.18 reporter, which contains two Ets binding sites, by 3.1-fold ( $\pm 0.5$ ) and Py<sub>2</sub> reporter, which contains two copies of adjacent Ets and AP-1 binding sites, by 2.3-fold ( $\pm 0.1$ ). Expression of VP16Ets2 activated E.18 and Py<sub>2</sub> transcription by 31.5-fold ( $\pm 7.3$ ) and 8.6-fold ( $\pm 3.1$ ), respectively (Fig. 5A). Preliminary analysis of the stable clones has shown the same pattern of E.18 reporter gene transactivation.<sup>2</sup> Thus, as assayed by these reporter genes in DT cells, expression of full-length Ets2 does indeed activate Ets-dependent transcription, and VP16-Ets2 is a significantly stronger transcriptional activator.

Stable DT cell lines were derived both with the VP16-Ets2 construct, and a VP16-only construct as a control. Soft agar growth of all 10 of the individual VP16-Ets2 clones examined was inhibited more than 4-fold (Fig. 2A). Several of these clones almost completely lost their ability to grow in soft agar (Fig. 5B). Morphological analysis revealed that, like full-length Ets2-expressing cell lines, the VP16-Ets2 lines had reverted to a flat morphology with clearly visible actin stress fibers (data not shown). The expression of VP16 alone did not cause impaired growth in soft agar for most of the stable clones (Fig. 2A). However, two of nine clones showed significant inhibition of soft agar growth, consistent with a previously reported observation that very high levels of VP16 expression inhibits Ras transformation (32). As described for the other Ets2 constructs above, parallel plating experiments and growth curve analysis showed that the almost complete loss of anchorage-independent growth of the VP16-Ets2 cell lines was not due to reduction of attached growth rate (data not shown).

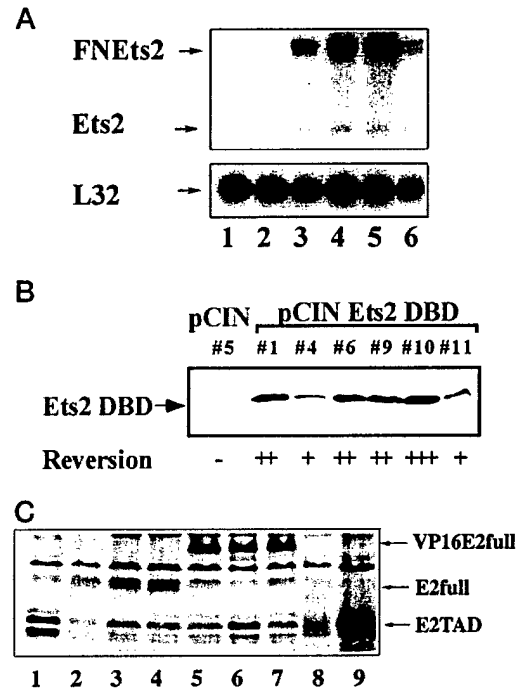
**Expression Levels of Ets2 Constructs in Reverted Cell Lines**—Because DT cells already express full-length Ets2, reversion of the transformed phenotype by the introduced full-length Ets2

<sup>2</sup> G. Foos and C. A. Hauser, unpublished data.



**FIG. 5. Reversion activity of full-length Ets2 constructs correlates with their transactivation activity.** *Panel A*, activation of Ets-dependent reporters in DT cells. Cotransfection assays in DT cells were performed using a minimal reporter gene ( $\Delta 56$ FosdE) or two different Ets-dependent reporters (E.18 or Py2) and the indicated Ets2 expression constructs. The -fold activation by the Ets2 constructs is the ratio of luciferase activity from each reporter gene relative to the same reporter gene with empty pCIN expression vector. *Panel B*, soft agar growth relative to the parental DT cells, of individual cell lines expressing various Ets2 constructs. The data are the average of duplicate samples.

expression construct is likely due to the elevated levels of Ets2 present in the reverted cell lines. To measure the amount of introduced full-length Ets2 mRNA relative to the endogenous Ets2 levels, RNase protection assays were performed with a



**FIG. 6. Expression levels of Ets2 constructs in the stable cell lines.** *Panel A*, RNase protection assay to compare endogenous and introduced Ets2 mRNA levels in the stable cell lines. The 400-base protected fragment from the introduced FNEts2 and the 300-base pair protected fragment from the endogenous Ets2 are indicated. Shown beneath is the control signal from the L32 ribosomal protein message from each RNA sample. The RNAs were from NIH3T3 cells (lane 1), or the DT-derived cell lines pCIN#5 (lane 2), or Ets2full#2, Ets2full#5, or Ets2full#6 (lanes 3–5). Lane 6 was RNA from a delayed onset tumor 14 days following injection of the Ets2#6 line into a nude mouse (see text). *Panel B*, reversion correlates to expression of E2DBD protein. Immunoblot analysis of equal amounts of whole cell extract from DT cell lines expressing the Ets2DBD or containing the empty pCIN expression vector, probed with an antibody against the FLAG epitope tag. The degree of reversion of the cell lines, as measured by loss of ability to grow in soft agar, is indicated by pluses. *Panel C*, immunoblot analysis of Ets2 construct protein levels, using anti-FLAG antibody and whole cell extracts from stable cell lines expressing the Ets2 constructs. pCIN#5 (lane 1), Ets2full#2, Ets2full#5, and Ets2full#6 (lanes 2–4), VP16Ets2full#1, VP16Ets2full#4, and VP16Ets2full#7 (lanes 5–7), and Ets2TAD#53 and Ets2TAD#52 (lanes 8 and 9). The sizes of the expressed Ets2TAD, Ets2full, and VP16Ets2full are indicated.

probe that could distinguish between the endogenous Ets2 and the FN-tagged introduced Ets2 (Fig. 6A). To determine how much overexpression was required for reversion, we tested a full-length Ets2 cell line that was only moderately reverted (Ets2full#2), and two others that showed strongly reduced growth in soft agar (Ets2full#5 and Ets2full#6, see Fig. 2B). Quantitative analysis of the data shown in Fig. 6A (see "Materials and Methods") revealed that the introduced Ets2 mRNA was expressed at an 8-, 12-, and 17-fold higher level than the endogenous Ets2 mRNA in Ets2full#2, Ets2full#5, and Ets2full#6, respectively. The introduced Ets2 did not appear to influence endogenous Ets2 expression, as normalization of the introduced Ets2 to L32 message (Fig. 6A) gave the same ratios of relative expression. Thus, we estimate that approximately 10-fold overexpression of Ets2 is required for strong reversion activity in DT cells. Consistent with this idea, the last lane in Fig. 6A shows that in a tumor that arose after a significant delay following injection of the Ets2#6 line into a nude mouse, (see below) introduced Ets2 mRNA had dropped from 17- to only 5-fold greater levels than endogenous Ets2.

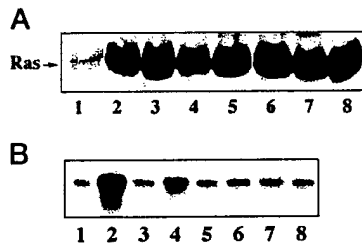


FIG. 7. Ras expression or ERK activity is not altered in reverted cell lines. Panel A, immunoblot of whole cell extracts using a pan-Ras antibody. Extracts were from NIH3T3 cells (lane 1) or the DT-derived cell lines pCIN#5 (lane 2), Ets2full#2, Ets2full#5, or pooled Ets2full clones (lanes 3–5), or E2TAD#51, E2TAD#52, or E2TAD#53 (lanes 6–8). Panel B, the endogenous MAPK activity in the stable cell lines was assayed by immune complex assay using an antibody which recognizes ERK1 and ERK2, and the radiolabeled signal from the myelin basic protein substrate is shown. The cells were either starved 18 h and then immediately harvested (lanes 1, 3, 5–8) or serum-stimulated for 5 min prior to harvest (lanes 2 and 4). The cell extracts analyzed were NIH3T3 (lanes 1 and 2), DT (lanes 3 and 4), or extracts from the reverted cells lines Ets2full#5, Ets2DBD#10, Ets2TAD#51, and VP16Ets2full#7 (lanes 5–8, respectively).

An assumption in the above assays comparing the apparent reversion strength of individual cell lines is that the various pCIN-Ets2 expression constructs are expressed over similar ranges, and that for each construct, the apparent reversion correlates to the expression level of the introduced protein. Six randomly selected Ets2DBD cell lines were assayed both for reduced growth in soft agar (reversion) and for Ets2DBD protein expression (Fig. 6B). These results show that, as postulated from the bicistronic message encoding Ets2DBD and G418 resistance, all of these G418-resistant cell lines express levels of the Ets2DBD protein detectable by Western blotting. The blotted Ets2DBD protein was detected using the anti-FLAG antibody directed against the N-terminal FLAG epitope tag of Ets2DBD. Comparison of the Ets2DBD expression levels and the reduction of soft agar growth in these cell lines (Fig. 6B) shows that there is indeed a correlation between Ets2DBD expression and apparent reversion in these cell lines.

The steady state protein levels of other Ets2 constructs in individual cell lines were similarly analyzed by Western blot. The relative differences in introduced full-length Ets2 mRNA levels (Fig. 6A) were reflected in the steady-state Ets2full protein levels (Fig. 6C). VP16Ets2full protein levels were also analyzed in several clones, and there was about 4-fold more VP16Ets2full#7 than Ets2full#5. Because the reverted VP16-Ets2full clones all had higher stable levels of protein expression than the Ets2full clones, we cannot exclude the possibility that the enhanced apparent reversion activity of the strongly transactivating VP16Ets2 constructs was due to dosage effects. The very high level of expression of E2TAD seen in the reverted E2TAD#52 line (Fig. 6C) was also seen in several other reverted E2TAD lines, and RNase protection analysis revealed that the Ets2TAD mRNA was approximately 100-fold more abundant than the endogenous Ets2 mRNA (data not shown).

**Ets2 Constructs Act Downstream of Ras Expression or MAP Kinase Activation.**—To determine that the Ets2 constructs were not reverting the transformed phenotype of DT cells by simply extinguishing the expression of oncogenic Ras, we confirmed that the high level of Ras normally seen in DT cells was still present in the reverted clones, as had been previously shown for EtsDBD constructs (23). Western blot analysis using pan-Ras antibody (Fig. 7A) shows that indeed, a DT line containing empty pCIN vector expressed much higher levels of Ras than NIH 3T3 cells, and (even on a shorter exposure) that reverted cell lines expressing either full-length Ets2 or the Ets2TAD

TABLE I  
Tumor formation in nude mice

$5 \times 10^5$  cells were subcutaneously injected into each dorsal flank of nude mice, and the tumors were measured by caliper on the indicated days. Tumor volumes were estimated as described under "Materials and Methods," and the average volume for 6–8 separate tumors derived from each cell line is shown. Statistically significant ( $p < 0.05$ ) reductions in tumor growth, relative to tumors from DT cells containing empty vector (pCIN#5), were determined using Student's *t*-test, and significantly reduced tumor volumes are indicated in bold text.

Cell line	Tumor volume (mm <sup>3</sup> )			
	Day 4	Day 6	Day 8	Day 10
pCIN5	19 ± 17	263 ± 159	1,331 ± 649	2,816 ± 1,272
full#5	4 ± 7	51 ± 39	<b>390 ± 246</b>	<b>1,223 ± 661</b>
full#6	8 ± 16	103 ± 62	<b>599 ± 379</b>	<b>1,467 ± 949</b>
DBD#10	16 ± 11	147 ± 98	<b>479 ± 228</b>	<b>1,736 ± 1,138</b>
TAD#53	8 ± 16	49 ± 51	<b>357 ± 277</b>	<b>1,618 ± 1,004</b>
VP16full#1	22 ± 13	76 ± 62	<b>630 ± 516</b>	<b>1,553 ± 973</b>
VP16full#7	7 ± 8	93 ± 87	<b>255 ± 245</b>	<b>1,197 ± 1,056</b>

still expressed high levels of Ras similar to that of DT cells. Therefore, the effects on the transformed phenotype by the Ets2 constructs were not due to reduced Ras expression.

The expressed Ets2 proteins are likely to act well downstream of Ras, and we postulated that they would also act downstream of the MAP kinases ERK1 and ERK2. These ERKs are targets of Ras/Raf/MEK signaling, but are still upstream regulators of Ets2 transcriptional activity (12). We therefore analyzed MAP kinase activity in several cell lines, using an immune complex assay. For this assay, the ERK1 and ERK2 were immune precipitated from whole cell extracts, and their activity was assayed using myelin basic protein as a substrate. Quantitation of the signals shown in Fig. 7B by phosphorimager analysis revealed that ERK activity was induced 10-fold by serum in NIH3T3 cells and 4-fold in DT cells. As has been previously observed (33), the basal ERK activity in the stably Ras-transformed cells was only modestly higher than in non-transformed cells. Fig. 7B shows there was not a significant difference between the basal levels of ERK activity found in the parental DT cells and in representative Ets2 construct-reverted cell lines, indicating that the Ets2 constructs were not altering ERK activity in the reverted cell lines.

**Ets2 Expression Reduces Tumorigenicity of DT Cells in Nude Mice.**—To determine whether the Ets2-mediated morphological reversion or increased anchorage-dependence seen *in vitro* reflects a reduced ability to form tumors, we performed tumorigenicity assays in nude mice. The growth of 6–8 tumors for each cell line in nude mice was followed by external measurement every 2 days, as described in Methods. The volume of tumors derived from the DT cell lines expressing various Ets2 constructs (cell lines shown above to exhibit reversion *in vitro*) were compared with that of a DT cell line containing an empty pCIN expression vector (Table I). The rapid tumor growth of the pCIN#5 cell line was not significantly different than another empty vector DT cell line pCIN#6 ( $n = 8$ ), or to the parental DT line ( $n = 4$ ), (data not shown). However, the tumor volumes were significantly smaller than pCIN#5 for both full-length Ets2 cell lines and both VP16-Ets2 cell lines on days 6, 8, and 10 (Table I). As described above (Fig. 3B and data not shown), these cell lines have the same attached growth rate as the pCIN#5 line in culture, which suggests that the expressed Ets2 specifically inhibited tumorigenicity. Reductions in tumor growth were also seen in the Ets2TAD#53 and Ets2DBD#10 cell lines, but the smaller tumor volumes were statistically significant only on days 6 and 8 for the Ets2TAD line and only on day 8 for the Ets2DBD line. Due to the very high initial growth rate of the control cell lines, by day 10 the tumors from pCIN or parental DT cells were quite large, and started to

exhibit reduced growth rates. This allowed the delayed tumors derived from the Ets2 construct-containing cell lines to catch up, and by days 12 and 14, none of the tumor volumes were significantly different from those of the pCIN#5 line (data not shown). It is likely that the significant delay of tumor growth represents the effects of the expressed Ets2 constructs, but in the absence of G418 selection, the subsequent *in vivo* selection of cells in which expression from the pCIN vector is reduced (see Fig. 6A and "Discussion"). Overall, the ability of full-length Ets2 or VP16-Ets2 expression to cause a substantial delay in tumorigenicity, and the ability of the Ets2TAD to cause a shorter delay in tumorigenicity correlates with their relative ability to cause reversal of the transformed phenotype in cell culture experiments.

#### DISCUSSION

It has been previously observed that stable expression of just the DNA binding domain (DBD) of the Ets factors Ets1, Ets2, or PU.1 reverses multiple features of the transformed phenotype in Ras-transformed NIH3T3 cells (23). In transient assays, these Ets DBD constructs exhibit a dominant inhibitory effect on Ets-dependent transcription, and on Neu/ErbB-2- and Ras-mediated activation of Ets-dependent gene expression (11, 22, 23). We show here that elevated expression of full-length Ets2, an activator of Ets-dependent transcription, can also specifically reverse the transformed phenotype of Ras-transformed NIH3T3 cells. The reverted phenotype in multiple stable Ets2-expressing cell lines included a reduction in anchorage-dependent growth, tumorigenicity, and saturation density. In addition, these Ets2 reverted cell lines exhibited more normal cell morphology, and reappearance of actin stress fibers which are lost in transformed fibroblasts. The inhibition of anchorage-independent growth by highly expressed Ets2 was specific, as anchorage-dependent growth was not inhibited in these cell lines. Reversion of the DT-derived Ets2-expressing cell lines was likely a direct consequence of Ets2 expression and not from selection of a secondary mutation, as 7/11 randomly picked stable DT cell lines generated with the Ets2 expression plasmid exhibited a strong ( $\geq 75\%$ ) reduction in anchorage-independent growth.

To test a potentially more specific inhibitory construct for Ets-dependent transcription, we also assayed the reversion activity of expressing the portion of Ets2 that does not bind DNA, the Ets2TAD. We previously found that high expression of this Ets2TAD, which presumably interacts with some limiting protein, could block Ras or Neu-mediated activation of an Ets-dependent reporter gene (11). In contrast to the ability of the Ets2DBD or full-length Ets2 to more completely reverse transformation, we show here that expression of Ets2TAD partially reversed the transformed phenotype of DT cells. Ets2TAD expression strongly inhibited anchorage-independent cell growth, but did not reverse transformed cell morphology. These findings suggest that the functions of Ets proteins in anchorage-independence and transformed morphology are separable, and that Ets factors impact on multiple pathways required in cellular transformation. In light of the differences in morphological reversion activity of Ets2 and the Ets2TAD, potential targets in reversion for Ets2 may include Rho family members or integrin-linked kinases.

Because phosphorylation of the Thr-72 residue of Ets2 has been found to be essential for the Ras-mediated increase in Ets2 transactivation activity (10, 11), we tested whether a Thr to Ala mutation would disrupt the reversion activity of highly expressed Ets2, both in the context of the Ets2 TAD, and in full-length Ets2. Although the Ets2(A72) mutation may have slightly reduced Ets2 reversion activity, the data showed that the Thr-72 residue was not essential for reversion activity in

either construct. Although Thr-72 phosphorylation is not essential for reversion activity, we can not exclude that these Ala-72 constructs could still act by competing for a kinase, as the kinase recognition sequence may be distinct from the phosphorylation site.

Inhibition of Ras transformation in fibroblasts has previously been observed only with Ets constructs that inhibit expression of Ets-dependent transcription, and thus it was somewhat unexpected that expression of full-length Ets2 had strong and broad reversion activity. It was previously hypothesized that the Ets DBD acts as a dominant negative Ets protein which blocks the activation of genes whose persistent activation by Ras signaling is required for maintaining the transformed phenotype (34). To assess whether the transactivation activity of the overexpressed Ets2 contributes to its reversion activity, we synthetically increased Ets2 transactivation activity by N-terminal addition of the VP16 transactivation domain. This VP16-Ets2 construct showed strongly enhanced transactivation activity, and had the strongest apparent reversion activity of any of the Ets2 constructs we tested, both in the *in vitro* assays and the tumorigenicity assays. These results further indicated that activation of Ets-dependent transcription can also lead to reversion. A related finding was recently reported in the colon cancer cell line DLD-1, where ectopic expression of full-length Ets1 caused a partial reversion of the transformed phenotype of these cells, and an Ets1 mutant that had lost its transactivation activity also lost its reversion activity (35). These findings with DLD-1 cells, in which activated K-Ras has been shown to play a key role in their transformation (36), are consistent with our present data indicating that increasing Ets-dependent transcription can reverse Ras-mediated cellular transformation. This ability of highly expressed Ets1 and Ets2 to reverse cellular transformation is in contrast to the initial characterization of Ets1 and Ets2 as proto-oncogenes, whose overexpression could transform NIH3T3 cells (20, 21). However, the rare appearance of transformed cells in these experiments suggested that selection for a secondary event was required for transformation (20, 21). In several experiments, we have failed to observe direct transforming activity of highly expressed Ets2 in NIH3T3 cells.<sup>3</sup>

Although it is difficult to compare the reversion strength of different expression constructs in stable cell lines, in our parallel analysis of the reversion activity of full-length Ets2 and the Ets2DBD, it appeared as though the full-length Ets2-expressing cell lines tested were more reverted than the Ets2DBD lines in all of the transformation assays. The fact that the Ets2DBD-expressing lines were less well reverted than similar previously described lines (23) is likely due to the fact that in the previous study, strong selection for morphological reversion (flat, highly adherent cells) was applied prior to scoring or assaying the reverted phenotype. Given the dose response for reversion seen with the randomly picked Ets2DBD (Fig. 6B), it is likely one could find more reverted Ets2DBD cell lines. We postulate that lack of sufficient Ets2 construct expression was also responsible for the eventual tumor growth in the tumorigenicity assay (Table I). It has been reported that, in the absence of selection, the neomycin resistance gene can silence a nearby CMV promoter (37). When we assayed the level of introduced full-length Ets2 mRNA in a tumor that had grown up after significant delay, we found that the overall Ets2 expression level had dropped to below what was required to observe reversion *in vitro* (Fig. 6A). Thus, although this study showed a clear *in vivo* effect of full-length Ets2 expression inhibiting tumor growth, a more stable expression system will

<sup>3</sup> C. K. Galang and C. A. Hauser, unpublished data.

be required to assay the long term efficacy of reversing tumorigenicity by altering Ets-dependent transcription.

There are several distinct mechanisms that could explain how Ets2 constructs with seemingly opposite activities (inhibition or activation of Ets-dependent transcription) could revert Ras-mediated transformation. If these Ets2 constructs act on common targets, it is possible they do so by displacing an Ets family negative regulator which becomes more active in Ras-transformed cells. In such a model, the activity of an Ets-family repressor would be required to maintain the transformed state. The inhibitory Ets2 constructs would displace this repressor, and the activating constructs would displace it and additionally activate expression of the genes whose expression causes reversion. Such a repressor must act in a promoter context distinct from E.18 or Py<sub>2</sub>, as we have found that Ets2DBD expression inhibits the transcription of these reporter genes in both NIH3T3 and DT cells (Ref. 11 and data not shown). Another possible common mechanism of reversion involves interaction of the Ets constructs with AP-1 family proteins, as both the Ets domain and the Ets2 TAD have been reported to physically interact with AP-1 family members involved in cellular transformation (38–40). However, we found that expression of the Ets2 TAD or DBD does not influence Ras or Her2/Neu activation of an AP-1-dependent reporter gene (11). Alternatively, the inhibitory and activating Ets2 constructs may have distinct targets. One possible target for reversion by activating Ets2 constructs is p21<sup>Cip1/Waf1</sup>, as high level stimulation of Raf, an upstream activator of Ets activity, activates p21<sup>Cip1</sup> expression (41–43). Expression of p21<sup>Cip1</sup> is also induced by an Ets transcription factor (44), and overexpression of p21<sup>Cip1</sup> can reverse anchorage-independent growth of transformed cells without interfering with their attached growth (45). Other possible targets for reversion through activation of Ets-dependent transcription include the tumor suppressors p53 and Rb. The p53 promoter has tandem Ets sites arrayed very similarly to the E.18 reporter gene (used in Fig. 5A), and p53 expression is increased upon Ets2 overexpression (46). There are also functional Ets binding sites in the Rb promoter (47), and elevated expression of either p53 or RB can reverse transformation (48, 49). Possible targets for inhibitory Ets2 constructs include the Ets2-regulated autocrine growth factor HB-EGF (41) and cyclin D1 (50), whose promoters have functional Ets binding sites. However, inhibition of targets such as cyclin D1 would not be expected to specifically block only anchorage-independent growth.

Overall, our studies show that altering Ets transcription factor activity by either inhibiting or activating Ets-dependent transcription can reverse Ras-mediated cellular transformation. In addition, the ability of a potentially more specific Ets-inhibitory construct (Ets2TAD) to partially reverse transformation suggests that Ets factors are involved in multiple pathways in Ras transformation. The dominant inhibitory and activating constructs we have used in this study likely act broadly on targets of the large family of Ets transcription factors, given the similarity of Ets factor DNA binding sequences. Ets factors whose activities are reported to be regulated by Ras signaling include Ets1, Ets2, PEA3, ERM, ER81, GABP $\alpha$ , and ERF (10, 24, 51–53), as well as the ternary complex Ets factors Elk, SAP-1, and SAP-2/NET (27, 54, 55). Therefore, our results with high level expression of Ets2 constructs should not be interpreted to mean that Ets2 is the critical Ets protein in cellular transformation, or that Ets2 is a bona fide tumor suppressor gene. Instead, we have used the Ets2 constructs as tools to explore the potential functions of Ets proteins in Ras transformation, and have found that Ets

proteins appear to have a central and complex role in regulating transformation. It is now of great interest to determine the mechanism and targets of Ets construct-mediated reversion, and to determine which kinds of Ets signaling are important in the transformed behavior of human epithelial-derived tumor cells.

## REFERENCES

1. Karim, F. D., Urness, L. D., Thummel, C. S., Klemsz, M. J., McKecher, S. R., Celada, A., Van Beveren, C., Maki, R. A., Gunther, C. V., Nye, J. A., and Graves, B. J. (1990) *Genes Dev.* 4, 1451–1453
2. Ghysdael, J., and Boureux, A. (1997) in *Oncogenes as Transcriptional Regulators, Vol. 1: Retroviral Oncogenes* (Yaniv, M., and Ghysdael, J., eds) pp. 29–88, Birkhäuser Verlag, Basel, Switzerland
3. Watson, D. K., McWilliams, M. J., Lapis, P., Lautenberger, J. A., Schweinfest, C. W., and Papas, T. S. (1988) *Proc. Natl. Acad. Sci. U. S. A.* 85, 7862–7866
4. Boulukos, K. E., Pognonec, P., Begue, A., Galibert, F., Gesquiere, J. C., Stehelin, D., and Ghysdael, J. (1988) *EMBO J.* 7, 697–705
5. Kola, I., Brookes, S., Green, A. R., Garber, R., Tyms, M., Papas, T. S., and Seth, A. (1993) *Proc. Natl. Acad. Sci. U. S. A.* 90, 7588–7592
6. O'Neill, E. M., Rebay, I., Tjian, R., and Rubin, G. M. (1994) *Cell* 78, 137–147
7. Brunner, D., Ducker, K., Oellers, N., Hafen, E., Scholz, H., and Klambt, C. (1994) *Nature* 370, 386–389
8. Rebay, I., and Rubin, G. M. (1995) *Cell* 81, 857–866
9. Klambt, C. (1993) *Development* 117, 163–176
10. Yang, B. S., Hauser, C. A., Henkel, G., Colman, M. S., Van Beveren, C., Stacey, K. J., Hume, D. A., Maki, R. A., and Ostrowski, M. C. (1996) *Mol. Cell. Biol.* 16, 538–547
11. Galang, C. K., Garcia-Ramirez, J., Solski, P. A., Westwick, J. K., Der, C. J., Neznanov, N. N., Oshima, R. G., and Hauser, C. A. (1996) *J. Biol. Chem.* 271, 7992–7998
12. McCarthy, S. A., Chen, D., Yang, B. S., Garcia-Ramirez, J. J., Cherwinski, H., Chen, X.-R., Klagsbrun, M. L., Hauser, C. A., Ostrowski, M. C., and McMahon, M. (1997) *Mol. Cell. Biol.* 17, 2401–2412
13. Wasylyk, C., Gutman, A., Nicholson, R., and Wasylyk, B. (1991) *EMBO J.* 10, 1127–1134
14. Wasylyk, C., Flores, P., Gutman, A., and Wasylyk, B. (1989) *EMBO J.* 8, 3371–3378
15. Bortner, D. M., Langer, S. J., and Ostrowski, M. C. (1993) *Crit. Rev. Oncogen.* 4, 137–160
16. Aoyama, A., and Klemenz, R. (1993) *Crit. Rev. Oncogen.* 4, 53–94
17. Chambers, A. F., and Tuck, A. B. (1993) *Crit. Rev. Oncogen.* 4, 95–114
18. Westwick, J. K., Cox, A. D., Der, C. J., Cobb, M. H., Hibi, M., Karin, M., and Brenner, D. A. (1994) *Proc. Natl. Acad. Sci. U. S. A.* 91, 6030–6034
19. Galang, C. K., Der, C. J., and Hauser, C. A. (1994) *Oncogene* 9, 2913–2921
20. Seth, A., and Papas, T. S. (1990) *Oncogene* 5, 1761–1767
21. Seth, A., Watson, D. K., Blair, D. G., and Papas, T. S. (1989) *Proc. Natl. Acad. Sci. U. S. A.* 86, 7833–7837
22. Langer, S. J., Bortner, D. M., Roussel, M. F., Sherr, C. J., and Ostrowski, M. C. (1992) *Mol. Cell. Biol.* 12, 5355–5362
23. Wasylyk, C., Maira, S. M., Sobieszczuk, P., and Wasylyk, B. (1994) *Oncogene* 9, 3665–3673
24. Sgouras, D. N., Athanasiou, M. A., Beal, G. J., Jr., Fisher, R. J., Blair, D. G., and Mavrothalassitis, G. J. (1995) *EMBO J.* 14, 4781–4793
25. Giovane, A., Sobieszczuk, P., Ayadi, A., Maira, S. M., and Wasylyk, B. (1997) *Mol. Cell. Biol.* 17, 5667–5678
26. Wang, L. C., Kuo, F., Fujiwara, Y., Gilliland, D. G., Golub, T. R., and Orkin, S. H. (1997) *EMBO J.* 16, 4374–4383
27. Giovane, A., Pintzas, A., Maira, S. M., Sobieszczuk, P., and Wasylyk, B. (1994) *Genes Dev.* 8, 1502–1513
28. Noda, M., Selinger, Z., Scolnick, E. M., and Bassin, R. H. (1983) *Proc. Natl. Acad. Sci. U. S. A.* 80, 5602–5606
29. Kitayama, H., Sugimoto, Y., Matsuzaki, T., Ikawa, Y., and Noda, M. (1989) *Cell* 56, 77–84
30. Rees, S., Coote, J., Stables, J., Goodson, S., Harris, S., and Lee, M. G. (1996) *BioTechniques* 20, 102–110
31. Clark, G. J., Cox, A. D., Graham, S. M., and Der, C. J. (1995) *Methods Enzymol.* 255, 395–412
32. Min, S., Crider-Miller, S. J., and Taparowsky, E. J. (1994) *Cell Growth Diff.* 5, 563–573
33. Ljungdahl, S., Linder, S., Sollerbrant, K., Svensson, C., and Shoshan, M. C. (1997) *FEBS Lett.* 249, 648–656
34. Langer, S. J., Bortner, D. M., Roussel, M. F., Sherr, C. J., and Ostrowski, M. C. (1992) *Mol. Cell. Biol.* 12, 5355–5362
35. Suzuki, H., Romano-Spica, V., Papas, T. S., and Bhat, N. K. (1995) *Proc. Natl. Acad. Sci. U. S. A.* 92, 4442–4446
36. Shirasawa, S., Furuse, M., Yokoyama, N., and Sasazuki, T. (1993) *Science* 260, 85–88
37. Artelt, P., Grannemann, R., Stocking, C., Friel, J., and Bartsch, J. (1991) *Gene (Amst.)* 99, 249–254
38. Bassuk, A. G., and Leiden, J. M. (1995) *Immunity* 3, 223–237
39. Sieweke, M. H., Tekotte, H., Frampton, J., and Graf, T. (1996) *Cell* 85, 49–60
40. Basuyaux, J. P., Ferreira, E., Stehelin, D., and Buttice, G. (1997) *J. Biol. Chem.* 272, 26188–26195
41. McCarthy, S. A., Samuels, M. L., Pritchard, C. A., Abraham, J. A., and McMahon, M. (1995) *Genes Dev.* 9, 1953–1964
42. Liu, A. Y., Corey, E., Vessella, R. L., Lange, P. H., True, L. D., Huang, G. M., and Nelson, P. S. (1997) *Prostate* 30, 145–153
43. Sewing, A., Wiseman, B., Lloyd, A. C., and Land, H. (1997) *Mol. Cell. Biol.* 17, 5588–5597
44. Michieli, P., Li, W., Lorenzi, M. V., Miki, T., Zakut, R., Givol, D., and Pierce,

- J. H. (1996) *Oncogene* **12**, 775-784
45. Funaoka, K., Shindoh, M., Yoshida, K., Hanzawa, M., Hida, K., Nishikata, S., and Fujinaga, K. (1997) *Biochem. Biophys. Res. Commun.* **236**, 79-82
46. Venanzoni, M. C., Robinson, L. R., Hodge, D. R., Kola, I., and Seth, A. (1996) *Oncogene* **12**, 1199-1204
47. Savoytsky, E., Mizuno, T., Sowa, Y., Watanabe, H., Sawada, J., Nomura, H., Ohsugi, Y., Handa, H., and Sakai, T. (1994) *Oncogene* **9**, 1839-1846
48. Eliyahu, D., Michalovitz, D., Eliyahu, S., Pinhasi-Kimhi, O., and Oren, M. (1989) *Proc. Natl. Acad. Sci. U. S. A.* **86**, 8763-8767
49. Kivinen, L., Pitkanen, K., and Laiho, M. (1993) *Oncogene* **8**, 2703-2711
50. Albanese, C., Johnson, J., Watanabe, G., Eklund, N., Vu, D., Arnold, A., and Pestell, R. G. (1995) *J. Biol. Chem.* **270**, 23589-23597
51. O'Hagan, R. C., Tozer, R. G., Symons, M., McCormick, F., and Hassell, J. A. (1996) *Oncogene* **13**, 1323-1333
52. Janknecht, R., Monte, D., Baert, J. L., and de Launoit, Y. (1996) *Oncogene* **13**, 1745-1754
53. Janknecht, R. (1996) *Mol. Cell. Biol.* **16**, 1550-1556
54. Gille, H., Sharrocks, A. D., and Shaw, P. E. (1992) *Nature* **358**, 414-417
55. Li, C., Lusic, A. J., Sparkes, R., Tran, S. M., and Gaynor, R. (1992) *Genomics* **13**, 658-664
56. Hauser, C. A., Der, C. J., and Cox, A. D. (1994) *Methods Enzymol.* **238**, 271-276
57. de Wet, J. R., Wood, K. V., DeLuca, M., Helinski, D. R., and Subramani, S. (1987) *Mol. Cell. Biol.* **7**, 725-737
58. Hauser, C. A., Westwick, J. K., and Quilliam, L. A. (1995) *Methods Enzymol.* **255**, 412-426
59. Reuter, C. W., Catling, A. D., and Weber, M. J. (1995) *Methods Enzymol.* **255**, 245-256
60. Neznanov, N. S., and Oshima, R. G. (1993) *Mol. Cell. Biol.* **13**, 1815-1823
61. Neznanov, N. S., Umezawa, A., and Oshima, R. G. (1997) *J. Biol. Chem.* **272**, 27549-27557



## Altered Ets transcription factor activity in prostate tumor cells inhibits anchorage-independent growth, survival, and invasiveness

Gabriele Foos<sup>1</sup> and Craig A Hauser<sup>\*1</sup>

<sup>1</sup>La Jolla Cancer Research Center, The Burnham Institute, La Jolla, California, CA 92037, USA

The Ets family of transcription factors are important downstream targets in cellular transformation, as altering Ets activity has been found to reverse the transformed phenotype of Ras transformed mouse fibroblasts and of several human tumor cell lines. To determine whether Ets factors are important targets in the largely uncharacterized aberrant signaling in prostate cancer, we have altered Ets activity in the prostate tumor cell line PPC-1, by stable expression of either full-length Ets2, or a dominant inhibitor of Ets activity, the Ets2 DNA binding domain (Ets2DBD). Analysis of multiple independent clonal cell lines revealed that expression of either Ets2 or the Ets2DBD inhibited the anchorage-independent growth of PPC-1 cells up to 20-fold. In contrast to our previous findings with Ras-transformed NIH3T3 cells, PPC-1 cell lines expressing either Ets2 or the Ets2DBD exhibited slower attached cell growth, increased Ets-dependent gene expression, and up to a 10-fold increase in apoptotic cell death. The p21<sup>cip1</sup> gene was identified as a potential target of altered Ets signaling. Interestingly, the two distinct Ets2 constructs had strikingly different effects on *in vitro* invasiveness. Expression of the Ets2DBD almost completely blocked PPC-1 cell invasion through Matrigel, whereas overexpression of full-length Ets2 did not inhibit invasion. Overall, these results demonstrate that the balance of Ets factor activity can regulate multiple aspects of the transformed phenotype of PPC-1 prostate tumor cells, including anchorage-independent growth, survival, and invasiveness. *Oncogene* (2000) 19, 5507–5516.

**Keywords:** prostate cancer; Ets2 overexpression; dominant negative Ets2; transformation

### Introduction

Despite the prevalence of prostate cancer, the molecular understanding of this disease is still quite limited. In the hope of identifying new therapeutic targets, much effort is being made to characterize the genetic and molecular alterations in the upstream signaling components which may cause aberrant prostate cell growth and metastases (Huncharek and Muscat, 1995; Shi *et al.*, 1996). We have taken a complementary approach, of starting to define, the function of more downstream signaling components,

the Ets transcription factors, by determining whether altering their function can specifically reverse features of the transformed phenotype of prostate tumor cells.

Several families of transcription factors link signal transduction pathways to gene expression. The Ets family of transcription factors act as mediators of normal and oncogenic signaling in a variety of cellular contexts (Ghysdael and Boureux, 1997; Dittmer and Nordheim, 1998). There are over 20 unique Ets family members characterized in humans, related by their conserved DNA binding (ETS) domain (Ghysdael and Boureux, 1997). The DNA binding specificities of these Ets family members are quite similar, and their functional specificity may largely depend on their pattern of expression; interactions with partner proteins, and signal transduction pathways (Graves and Petersen, 1998). A large variety of transformation-associated genes contain adjacent binding sites for both Ets and AP-1 family transcription factors, and such elements mediate transcriptional activation from a wide range of activated oncogenes (Wasylyk *et al.*, 1989). We showed that Ets binding sites alone were also sufficient to confer strong Ras-responsiveness to a minimal promoter-containing reporter gene (Galang *et al.*, 1994), and that Ras signaling through ERK1/2 mediates specific phosphorylation and increased trans-activation activity of Ets2 on such a reporter (Yang *et al.*, 1996; McCarthy *et al.*, 1997). Many other Ets transcription factors have also been found to be targets of Ras pathway signaling (reviewed in Ghysdael and Boureux, 1997; Wasylyk *et al.*, 1998).

Ets factors are not only downstream targets of oncogene signaling, but they also play an important role in mediating the transformed phenotype. Analysis with dominant inhibitory Ets2 constructs indicates that Ets factors are required for the initiation of murine fibroblast transformation by oncogenic Ras or Neu (Langer *et al.*, 1992; Galang *et al.*, 1996). In addition, stable expression of the DNA binding domain (the ETS domain) from several divergent Ets family members was found to reverse the transformed phenotype of stably Ras-transformed NIH3T3 cells, but not to inhibit attached cell growth (Wasylyk *et al.*, 1994). Surprisingly, expression of full-length Ets2 (an activator of Ets-dependent transcription), or an even more powerful activator (VP16-Ets2) in Ras transformed NIH3T3 cells reversed their transformed phenotype more efficiently than expression of just the Ets2 DNA binding domain (Foos *et al.*, 1998). While these approaches using dominant acting Ets constructs do not reveal which particular Ets factors may be involved in transformation, they are of value in establishing the importance of this large family of transcription factors in this process.

\*Correspondence: CA Hauser, La Jolla Cancer Research Center, The Burnham Institute, 10901 North Torrey Pines Road, La Jolla, CA 92037, USA  
Received 19 April 2000; revised 18 September 2000; accepted 22 September 2000

Ets factors also play a role in the transformed phenotype of spontaneously arising human tumor cells. Expression of the Ets2 DNA binding domain (Ets2DBD) inhibited anchorage-independent growth and invasiveness of the BT-20 breast tumor cell line (Sapi *et al.*, 1998). Expression of full-length Ets1 was also found to reverse the transformed phenotype of the human DLD-1 colon tumor cell line, and this reversion activity was lost in an Ets1 point mutant that had lost transactivation activity (Suzuki *et al.*, 1995). Altered Ets activity has been reported to sensitize tumor cells to apoptotic death. Expression of an Ets1 splice variant induced apoptosis in serum starved DLD-1 colon tumor cells (Huang *et al.*, 1997), PU.1 expression sensitized erythroleukemia (MEL) cells to DMSO-induced apoptosis (Yamada *et al.*, 1997), and expression of Elk1 sensitized MCF-7 breast tumor cells to apoptosis upon calcium ionophore treatment (Shao *et al.*, 1998).

The direct mutational activation of Ras in prostate tumors appears to be quite infrequent (Konishi *et al.*, 1997), and activating *ras* mutations are not present in the commonly used prostate tumor cell lines such as PC-3, DU145, or LNCaP (Gumerlock *et al.*, 1991). However, a variety of other upstream signaling components converge on Ets factors. Ets2 expression is elevated in several prostate tumor specimens (Liu *et al.*, 1997), and Ets factors activate the expression of the maspin tumor suppressor in normal prostate epithelial cells (Zhang *et al.*, 1997). Androgen receptor interaction with Ets proteins is reported to downregulate expression of matrix metalloproteinases in prostate tumor cells (Schneikert *et al.*, 1996). In a preliminary analysis of the role of Ets factors in prostate tumor cell lines, expression of either an Ets2 antisense construct or the Ets2 DBD reduced the size of soft agar colonies formed by PC3 or DU145 cells (Sementchenko *et al.*, 1998). Much of what has thus far been learned about the molecular biology of prostate cancer has come from the analysis of established prostate tumor cell lines (Royai *et al.*, 1996; Webber *et al.*, 1997). We have utilized the hormone-independent metastatic human prostate tumor cell line PPC-1, stably expressing two distinct dominant acting Ets2 constructs, as an initial model system to broadly assess the function of Ets factors in multiple criteria of transformation. We demonstrate here, that in addition to the previously reported effects on colony size (Sementchenko *et al.*, 1998), that Ets-dependent gene expression affects many of the transformed features of this prostate tumor cell line, including anchorage-independence, apoptosis, motility, and invasiveness.

## Results

### *Generation of PPC-1 prostate tumor cell lines stably expressing Ets2 constructs*

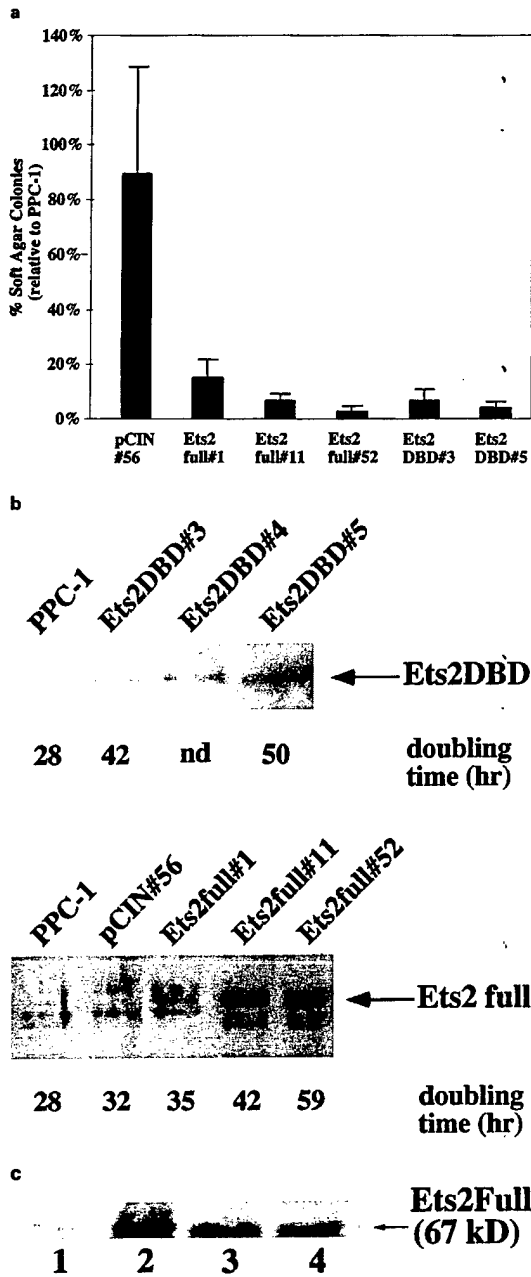
To test whether Ets factor activity is important for the transformed phenotype of a human prostate tumor cell line, we generated PPC-1 cell lines expressing Ets2 constructs designed to either inhibit or activate Ets-dependent transcription. The PPC-1 cell line was originally described as derived from a primary prostatic carcinoma (Brothman *et al.*, 1989).

However, subsequent karyotypic analysis (Chen, 1993) has led to the conclusion that PPC-1 cells are actually a diverged clonal variant of the prostate tumor metastasis-derived PC-3 cell line (www.ATCC.org), and their similar phenotypes support this idea. PPC-1 cells exhibit a highly transformed phenotype, including androgen independent and anchorage-independent growth. PPC-1 cells are invasive in *in vitro* assays (Wasilenko *et al.*, 1996), and are both tumorigenic and metastatic in nude mice (Brothman *et al.*, 1989, 1991). PPC-1 cells were transfected with expression constructs for either the Ets2 DNA binding domain, for full-length Ets2, or the empty expression vector, pCIN4. Multiple independent stable clones were generated with each construct. In the pCIN4 vector, G418 resistance is conferred by the 3' gene in a bicistronic message. Therefore, the G418-resistant clones that were selected should all express the 5' Ets2 construct. There were approximately 10-fold fewer stable colonies generated with the full-length Ets2 expression construct relative to the other two plasmids, indicating possible toxicity of Ets2 overexpression in PPC-1 cells (see below). Initial analysis revealed that six of eight randomly selected clones generated with the Ets2DBD and seven of 12 generated with full-length Ets2 expressed easily detectable amounts of these constructs.

### *Expression of either full-length Ets2 or the Ets2DBD alone specifically inhibits anchorage-independent PPC-1 cell growth*

To determine whether expression of full-length Ets2 or the Ets2 DNA binding domain alone could specifically inhibit the ability of PPC-1 cells to grow in an anchorage-independent manner, we compared the ability of the various cell lines to grow in soft agar relative to their ability to grow attached in normal tissue culture dishes. Preliminary analysis revealed that virtually all of the Ets2DBD or full-length Ets2-expressing clones exhibited significantly impaired growth in soft agar, whereas none of six pCIN4 vector only-containing clones assayed showed this reduction in anchorage-independent growth. Subsequently, two pCIN4 clones, two Ets2DBD expressing clones, and three full-length Ets2-expressing clones were then chosen as representative cell lines for the detailed analysis described below. Figure 1a shows that PPC-1 cell clones expressing either the Ets2DBD or full-length Ets2 showed a strong inhibition of soft agar growth relative to the parental PPC-1 cells or lines containing empty pCIN4 expression vector, with some Ets2full and Ets2DBD expressing clones exhibiting more than a 10-fold reduction in soft agar colony formation. Parallel plating experiments on tissue culture dishes, using the same dilution of cells used in the soft agar assay, showed that the Ets2 construct-expressing clones could form the same number of colonies as control cell lines (data not shown).

Expression of the introduced Ets2 constructs in the PPC-1 cell lines was measured by immunoblotting of whole cell extract with an antibody directed against the FLAG epitope tag on the Ets2 and Ets2DBD constructs. A range of full-length Ets2 expression was seen in the different clones derived with the Ets2full expression construct (Figure 1b), with E2full#11 and



**Figure 1** Expression of Ets2 constructs strongly inhibits anchorage-independent growth of PPC-1 cells, and reduces their attached growth rate. (a) Individual stable PPC-1 cell clones expressing the Ets2DBD, full-length Ets2, or the empty vector pCIN were assayed for their ability to grow in soft agar. Soft agar growth is expressed as per cent colony formation relative to the PPC-1 parental cell line in each experiment. The indicated averages and standard deviation were from duplicates of at least two independent experiments. (b) Immunoblot analysis of Ets2 protein levels, using anti-Flag M5 antibody and whole cell extracts from stable cell lines expressing full-length Ets2 or the Ets2DBD. The specific signals from Ets2 (67 kDa) and Ets2DBD (22 kDa) are indicated with an arrow. The doubling time of each cell line attached to tissue culture dishes is indicated beneath the corresponding lane. (c) Immunoblot analysis of introduced and endogenous Ets2 in PPC-1 whole cell extract, using Ets2(C-20) antibody. Lane 1, PPC-1 cells; lane 2, cells transiently transfected with the Ets2 expression construct; lanes 3 and 4, clones Ets2full#11 and Ets2full#1, which stably overexpress Ets2

E2full#52 showing high Ets2 expression, and E2full#1 expressing moderate amounts of Ets2. The amount of Ets2 expression in these lines (Figure 1b) corresponded to the degree of soft agar growth inhibition, as shown in Figure 1a. Similarly, a range of Ets2DBD expression was seen in the individual stable PPC-1 cell lines derived with Ets2DBD expression construct, and a clone expressing a high amount of Ets2DBD (Ets2DBD#5) showed the greatest inhibition of soft agar growth (Figure 1a and data not shown). Because of the selective pressure against high Ets2 construct expression (see below), there was some variation over time in the absolute amount of Ets2 construct expressed in the stable cell lines. However, the generally high or low Ets2 construct expression was stably maintained in these PPC-1 cell clones throughout passaging required to complete the various biological assays (data not shown).

The amount of introduced full-length Ets2 relative to the endogenous Ets2 in PPC-1 cells was estimated by immunoblotting using an Ets2-specific antibody. Quantitative analysis of the signals shown in Figure 1c revealed that the Ets2full#11 and Ets2full#1 clones were expressing about eight- and fivefold more Ets2 than the parental cells, respectively. Thus, these stable PPC-1 cell clones are significantly overexpressing Ets2, and the eightfold overexpressing Ets2full#11 line exhibits strong inhibition of both attached and soft agar cell growth. Extract from PPC-1 cells transiently transfected with the Ets2 expression construct (Figure 1c, lane 2) was used to confirm the identity of the Ets2 band, and use of a distinct Ets2-specific antibody that we generated (McCarthy *et al.*, 1997) gave similar quantitative results (data not shown). Overall, expression of either full-length Ets2 or just the DNA binding domain of Ets2 specifically inhibited the anchorage-independent growth of PPC-1 cells.

*Expression of Ets2 or the Ets2DBD increases the attached cell doubling time*

We previously found that expression of full-length Ets2 or the Ets2DBD strongly inhibited the anchorage-independent growth of a Ras-transformed NIH3T3 cell line, but did not inhibit its attached cell growth (Foos *et al.*, 1998). In contrast, we observed that the Ets2 construct-expressing PPC-1 clones formed smaller attached cell colonies and grew more slowly than the PPC-1 cell lines containing the empty pCIN4 expression vector. Analysis of the attached cell growth rate of the PPC-1 clones (Figure 1b) revealed that the clones expressing high levels of either Ets2 or the Ets2DBD showed a large increase in doubling time. While the parental PPC-1 cells had a doubling time of 28 h, the lines expressing high levels of full-length Ets2 (#11 and #52) had doubling times of 42 and 59 h respectively. Similarly, the line expressing the most Ets2DBD (#5) had a 50 h doubling time. The slower growth rate of Ets2 or Ets2DBD-expressing cells raised the question whether the failure to form visible soft agar colonies by these clones was simply due to these cells taking longer to form colonies. Examination of soft agar colonies stained with the vital dye INT showed that after 3 weeks of growth, PPC-1 colonies consisted of hundreds of metabolically active cells, whereas the colonies from the Ets2-expressing PPC-1 cell lines consisted of only a

few metabolically inactive cells (data not shown). Clearly this difference in the soft agar growth was not simply due to a twofold reduction in the attached cell growth rate.

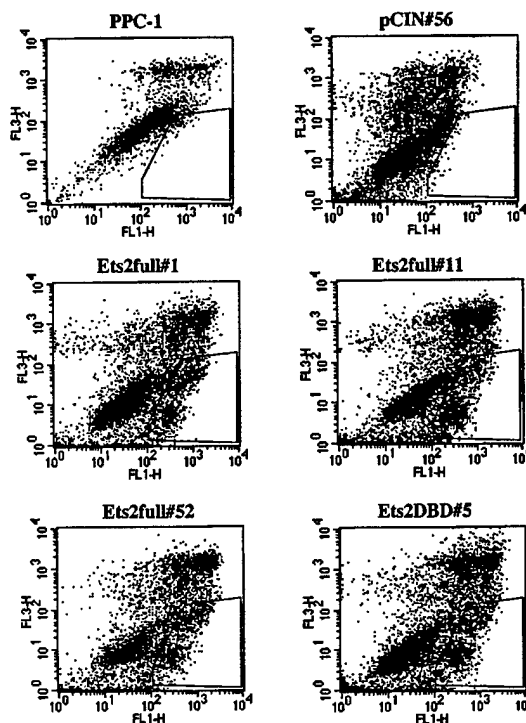
*Increased apoptotic cell death in PPC-1 cells expressing Ets2 constructs*

We observed in the routine culturing of stable PPC-1 clones expressing either the Ets2DBD or full-length Ets2, that in addition to a slower apparent growth rate (Figure 1b), there was a significantly larger number of dead and dying cells present. This cell death was not observed in cultures of the parental PPC-1 cells or in clones generated with the empty pCIN4 vector. Morphological examination of cells stained with acridine orange and ethidium bromide revealed that multiple clones expressing either the Ets2DBD or full-length Ets2 showed up to a ninefold increase in the number of cells exhibiting membrane blebbing or nuclear condensation, relative to the parental cell line PPC-1 or pCIN empty vector clones (data not shown). Such morphological changes suggested a significant portion of the Ets2 construct-expressing cells were apoptotic.

As an independent assay for apoptotic death, we analysed whether these cells exhibited membrane inversion, an early event in apoptosis. The cells were stained with fluorescein-conjugated annexin-V and propidium iodide, and then analysed by FACS. The results of a representative experiment are shown in Figure 2. In both the parental cell line PPC-1 and the empty vector control line pCIN#56, very low levels of Annexin-V positive and propidium iodide negative (apoptotic) cells were present (1.9 and 0.9% respectively). However, in PPC-1 cells expressing a high amount of Ets2, Ets2full#52, 16.5% of the cells were scored as apoptotic. Similarly, Ets2DBD expressing cell lines also exhibited increased apoptosis, with 11.5% of the cells scored as apoptotic in Ets2DBD#5, the high Ets2DBD expressing line. The level of apoptosis in these asynchronously dying cells was likely even higher than was scored in Figure 2, as to exclude possibly necrotic cells, the Annexin V positive cells that were also propidium iodide stained were not counted. Multiple independent experiments yielded similar results, with an increase in apoptotic cells for the Ets2 full lines and the Ets2DBD lines with high levels of Ets2 construct expression. Thus, stable overexpression of either the Ets2DBD or full-length Ets2 leads to a dramatic increase in apoptosis in PPC-1 cells.

*Expression of the Ets2DBD has opposite effects on Ets-dependent reporter genes in PPC-1 cells and MDA-MB-435 cells*

To determine whether Ets2DBD also acts as a dominant inhibitor of Ets dependent transcription in PPC-1 cells, we compared the effects of this construct on Ets dependent reporter constructs in PPC-1 cells and the MDA-MB-435 breast tumor cell line (Figure 3a). Empty expression vector, or an expression construct for full-length Ets2 (pCINE2full), or for the Ets2DBD (pCINEts2DBD) was cotransfected with either the minimal promoter-containing Δ56-Fos-Luc reporter, this reporter with multiple palindromic Ets2



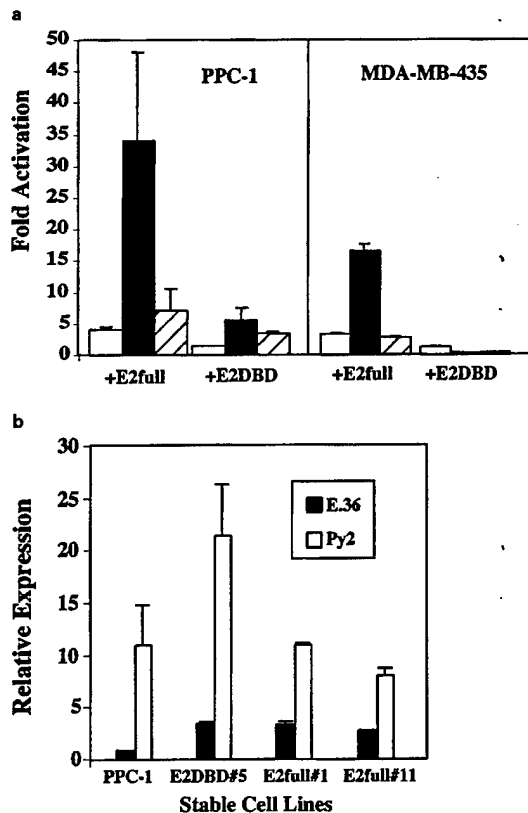
Cell line	% Annexin-V positive/ Propidium iodide negative
PPC-1	1.9
pCIN#56	0.9
Ets2full#1	12.1
Ets2full#11	13.8
Ets2full#52	16.5
Ets2DBD#5	11.5

Figure 2 Expression of Ets2 or Ets2DBD leads to increase of apoptosis in PPC-1 cells. Representative FACS analysis of PPC-1 cells or clones expressing full-length Ets2 or Ets2DBD, stained with fluorescein-conjugated Annexin-V and propidium iodide. The cells scored positive for Annexin-V and negative for propidium iodide (apoptotic) are indicated by the box. The percentage of apoptotic cells present in the culture, relative to the total number of cells for each line, is summarized at the bottom

binding sites (E.36) which is preferentially activated by Ets2, or with multiple Ets-AP-1 elements (Py2), which is activated by several Ets factors including Ets2. As expected, increased expression of full-length Ets2 activated the expression of the Ets-dependent E.36-luc reporter gene in both cell lines (Figure 3a). Unexpectedly, expression of the Ets2DBD in PPC-1 cells activated E.36-luc reporter gene expression eightfold and Py2-luc fourfold. In contrast, and similar to our previous observations in NIH3T3 cells (Galang *et al.*, 1996), the Ets2DBD inhibited expression of the E.36-luc and Py2-luc reporters in MDA-MB-435 cells (Figure 3a).

*Ets-dependent gene expression is elevated in PPC-1 cells stably expressing Ets2 or Ets2DBD*

To determine whether similar alterations in Ets-dependent gene expression occur in the PPC-1 clones



**Figure 3** Activation of Ets-dependent reporter genes in PPC-1 lines by both full-length Ets2 and the Ets2DBD. (a) Results of transient cotransfection assays in the indicated cell lines. The cells were cotransfected with the  $\Delta 56$ fos (white bars), E.36 (black bars) or Py2 (striped bars) reporters, and with either empty pCIN4 expression vector or expression constructs for Ets2DBD or full-length Ets2 (E2full). The fold activation is the luciferase activity of each reporter cotransfected with E2DBD or E2full, relative to luciferase activity from that reporter in the same cell line cotransfected with pCIN4. (b) Relative expression of reporter genes transfected into PPC-1 cell lines stably expressing Ets2 constructs. The expression of the E.36 or Py2 reporters relative to the expression of  $\Delta 56$ fos in each indicated cell line is shown. Assays were done in parallel experiments, and the average and standard error of the assays is shown

stably expressing the various Ets2 constructs, we used these stable cell lines for additional reporter gene analysis. Each stable clone was transfected with the  $\Delta 56$ Fos reporter, or the Ets-dependent reporter genes E.36 or Py2. Figure 3b shows the expression of E.36 or Py2 relative to the expression of  $\Delta 56$ Fos in the same line. Similar to the unexpected results obtained in the transient cotransfection studies above, there was increased expression of the E.36 and Py2 reporter genes in the Ets2DBD overexpressing PPC-1 line. The expression of Py2 relative to  $\Delta 56$ Fos (22-fold) in this line was higher than the control cell line (12-fold) or for the full-length Ets2 expressing lines tested (8- and 11-fold).

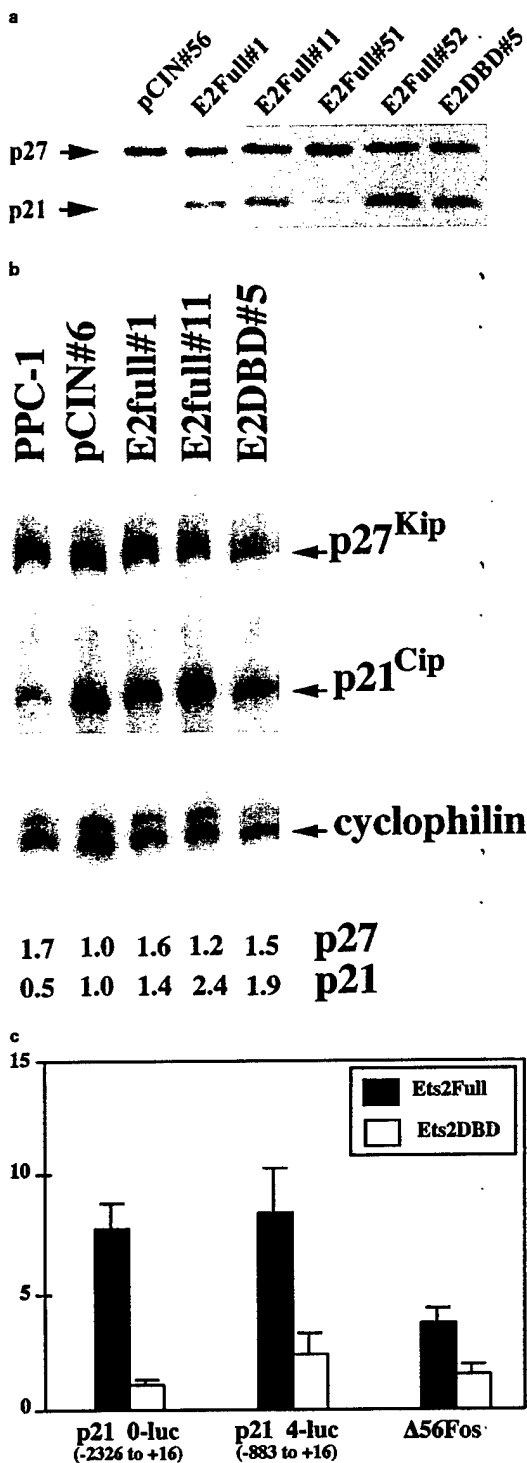
*PPC-1 cells expressing Ets2 or Ets2DBD have increased levels of p21<sup>Cip</sup>*

The altered growth properties and increased apoptosis observed in Ets2 construct-expressing PPC-1 cells

suggests that the cyclin-dependent kinase inhibitors could be a potential downstream target. Expression of p21<sup>Cip</sup> is activated by hyperstimulation of the Ras/Raf signaling pathway (Woods *et al.*, 1997), and p21<sup>Cip</sup> has been reported to be a direct transcriptional target of overexpressed Ets factor E1AF (Funaoka *et al.*, 1997). We measured the steady-state levels of p21<sup>Cip</sup> and the related p27<sup>Kip1</sup> protein in the stable cell lines using immunoblot analysis (Figure 4). Relative to the low levels of p21<sup>Cip</sup> protein in the parental PPC-1 cell line or the pCIN empty vector lines, p21<sup>Cip</sup> protein expression was significantly elevated in multiple PPC-1 cell lines that express either full-length Ets2 or Ets2DBD (Figure 4a). The highest amount of p21 protein in the Ets2full lines was observed in Ets2full#52, a high expresser of Ets2, whereas the lowest p21 induction was in Ets2full#51 (Figure 4a), a clone with little Ets2 expression (data not shown). Interestingly, elevated p21<sup>Cip</sup> levels were also observed in PPC-1 lines reverted by expression of the dominant inhibitory Ets2DBD construct (Figure 4a and data not shown). The elevation of p21<sup>Cip</sup> levels by expression of either full-length Ets2 or Ets2DBD may be a result of direct transcriptional regulation of p21<sup>Cip</sup> by Ets factors, as in PPC-1 cells, both of these Ets2 constructs can cause activation of Ets-dependent transcription.

To measure the amount of p21<sup>Cip</sup> and p27<sup>Kip1</sup> mRNA in the reverted cells, we performed RNase protection experiments (Figure 4b). The levels of p21 and p27 expression were normalized to the expression of the internal cyclophilin control for each sample. Nearly identical results were obtained normalizing to a GAPDH internal control (data not shown). Quantitative analysis revealed that p27<sup>Kip1</sup> mRNA levels were not significantly altered compared to both negative control lines, but p21<sup>Cip</sup> expression was elevated in the lines expressing the most full-length Ets2 or Ets2DBD, with the maximum observed stimulation of 2.4-fold in the Ets2full#11 line (see Figure 4b). To determine whether the elevated p21 expression could be a transcriptional consequence of altered Ets activity in PPC-1 cells, we tested the ability of reporter genes containing portions of the p21<sup>Cip</sup> promoter to be transactivated by cotransfection of Ets2 or the Ets2DBD in these cells (Figure 4c). The p21<sup>Cip</sup> reporter 0-luc was maximally activated 7.6-fold by full-length Ets2, similar to the 8.4-fold Ets2 activation of the truncated 4-luc p21 reporter. Dose-response analysis indicated that this amount of Ets2 expression construct also gave maximal expression of the synthetic Ets2-responsive reporter E.36-luc (data not shown). While expression of the Ets2 DBD did not exhibit significant effects with this reporter, the stimulation of p21<sup>Cip</sup> expression by full-length Ets2 in this cotransfection assay was significantly larger than that seen with the  $\Delta 56$ fos-luc control reporter (Figure 4c). Overall, the effects of Ets2 on both the endogenous p21 and the p21 reporter genes suggests that p21 may be a direct target of Ets signaling in the reverted PPC-1 cells.

*Decreased motility in cell lines expressing Ets2 constructs* We examined motility of the PPC-1-derived cell lines through an 8  $\mu$ m pore uncoated filter in response to a serum gradient. As shown in Figure 5a,



**Figure 4** PPC-1 cells expressing Ets2 or Ets2DBD express increased levels of p21<sup>CIP/WAF</sup> and p27<sup>KIP1</sup> protein levels. (a) Immunoblot assay of p21<sup>CIP/WAF</sup> and p27<sup>KIP1</sup> protein levels. Equal amounts of protein from whole cell extracts were immunoblotted and probed with a combination of antibodies against p21<sup>CIP/WAF</sup> and p27<sup>KIP1</sup>. The specific signals for p21 and p27 are indicated. (b) Multiplex RNase protection assay where RNA samples from each indicated cell line were simultaneously analysed with probes from p27, p21, and cyclophilin. The indicated bands were quantitated and normalized

PPC-1 cells expressing either Ets2full or Ets2DBD showed significantly reduced motility in this assay, exhibiting 17 to 37% of the motility of the parental cell line PPC-1. A control cell line, pCIN#56, which contains only the empty expression vector, did not show significantly altered motility. An average of 600 PPC-1 cells migrated through the membrane in 16 h, using the conditions described in Materials and methods. The reduction in motility was proportional to the level of the expression of either of the different Ets2 constructs (see Figure 1b). The strong reduction in apparent motility was not simply a consequence of reduced cell division, because the measurements took place over less than one doubling time. Overall, stable expression of either full-length Ets2 or the Ets2DBD inhibited PPC-1 cell motility.

**Overexpression of Ets2DBD but not full-length Ets2 in PPC-1 cells blocks in vitro invasion** Invasion through basement membranes is an important step in the metastatic process. We have assayed the *in vitro* invasion potential of PPC-1 cells expressing full-length Ets2 or Ets2DBD, by measuring their ability to traverse through filters coated with reconstituted basement membrane (Matrigel). NIH3T3 cell conditioned RPMI media was used as a chemoattractant. Figure 5b shows that the cell lines expressing the Ets2DBD exhibited significantly reduced invasiveness in these assays. For the Ets2DBD#5 line, the percentage of invading cells was comparable to that of the normal NIH3T3 cells (Figure 5b). Interestingly, despite the parallel changes in phenotype of full-length Ets2 expressing PPC-1 cells with the Ets2DBD lines in the other assays described above, the cell lines expressing full-length Ets2 showed no reduction in their invasion activity. If anything, PPC-1 cells expressing full-length Ets2 were slightly more invasive than the parental PPC-1 cells (Figure 5b). These results suggest that full-length Ets2 and the Ets2DBD, have some distinct targets in PPC-1 tumor cells.

**Discussion**

In this study, we have utilized prostate tumor cell line clones stably expressing dominant acting Ets2 constructs to demonstrate that Ets factors can mediate diverse aspects of the transformed phenotype. Altering Ets-dependent gene expression in two distinct ways, by either stably expressing an activator (full-length Ets2) or a dominant inhibitor (the Ets2DBD) greatly inhibited anchorage-independent PPC-1 cell growth. These results were similar to what we previously observed with Ras transformed murine fibroblasts

to the cyclophilin internal control. The relative expression shown below the lanes are the ratio of the normalized signal to the corresponding signal from the empty vector-containing pCIN#6 cell line. (c) Transient cotransfection assay of a p21 reporter gene with Ets2 constructs in PPC-1 cells. The cells were cotransfected with the p21 reporters 0-luc or 4-luc, or the Δ56fos-luc reporter, and either empty expression vector (pCIN4), or Ets2full or Ets2DBD expression constructs. The fold activation is the ratio of luciferase activity of the reporter when cotransfected with Ets2full (white bars) or Ets2DBD (black bars) relative to the same reporter cotransfected with pCIN4

(Foos *et al.*, 1998), and we have also observed that the Ets2DBD DNA binding activity is required for reversion activity (C Galang and CA Hauser, unpublished observations). However, in contrast to reverted NIH3T3 cells, high expression of either full-length Ets2 or the Ets2DBD in PPC-1 cells caused an apparent reduction in the attached cell growth rate. This was due, at least in part, to the fairly dramatic induction of apoptosis. While expression of the Ets2DBD or full-length Ets2 had several common effects on PPC-1 cells, a striking difference was observed in the invasive behavior of the cell lines expressing these distinct Ets2 constructs. PPC-1 cells expressing the Ets2DBD almost completely lost their *in vitro* invasion activity, whereas cell lines expressing full-length Ets2 were fully invasive. Thus, these two types of Ets2 constructs are not acting through identical mechanisms. The observed effects of altered Ets activity on tumor cell growth, survival, and invasiveness, were verified in multiple independent clonal cell lines for each construct, and the effects correlate with the levels of Ets2 construct expression.

Altering the balance of Ets-dependent gene expression had a strong effect on PPC-1 cell survival, as there was up to a 10-fold increase in the number of apoptotic cells observed in Ets2 construct-expressing PPC-1 clones (Figure 2). This somewhat unusual steady-state apoptosis is likely the consequence of selecting for stable PPC-1 clones expressing enough of the Ets2/NPT bicistronic message to confer G418 resistance, but not so much Ets2 as to cause an amount of cell death which overrides the cell growth. Because G418 does not induce apoptotic death (Chen *et al.*, 1995), the observed apoptosis is not simply from insufficient G418 resistance. The mechanism by which apoptotic pathways are regulated by Ets factors are not clear. In the case of the p42 Ets1 splice variant, expression of this truncated protein, but not full-length Ets1, sensitized DLD-1 colon tumor cells to Fas-mediated apoptosis, and this cell death required caspase-1 activation (Li *et al.*, 1999). In contrast, expression of full-length Ets2 was reported to inhibit apoptosis in macrophages upon growth factor withdrawal, and was postulated to act through transcriptional induction of bcl-x(L) (Sevilla *et al.*, 1999). In *Drosophila*, a genetic study found that loss-of-function allele of the pointed P2 Ets factor sensitized eye cells to apoptosis upon *hid* overexpression (Kurada and White, 1998). Unlike these previous reports, where altered Ets factor activity sensitized cells to apoptosis-inducing agents, apoptosis occurred spontaneously in the Ets2 construct-expressing PPC-1 cells described here. Thus, Ets signaling can have a strong direct effect on the survival of this prostate tumor cell line.

We initially postulated that full-length Ets2 acts as an activator of Ets-dependent transcription, and the Ets2DBD would bind non-productively to Ets binding sites to broadly inhibit Ets-dependent gene expression in PPC-1 cells. This was the result we observed in NIH3T3 cells (Galang *et al.*, 1996; Foos *et al.*, 1998). However, with the exception of invasiveness, there was extensive similarity in the altered phenotype of PPC-1 clones expressing either the presumptive activator or inhibitor of Ets-dependent transcription. When we directly tested the transcriptional effects of full-length Ets2 and the Ets2DBD in PPC-1 cells using transient

cotransfection assays, we found that while full-length Ets2 does indeed activate expression of the Ets-dependent reporters, the Ets2DBD also unexpectedly activated reporter gene expression (Figure 3a). This transactivation by the Ets2DBD was not only in contrast to the results in NIH3T3 cells, but also the opposite result of that seen in the MDA-MB-435 breast tumor cells analysed in parallel with the PPC-1 cells (Figure 3a). Analysis of PPC-1 clones stably expressing either Ets2 or the Ets2DBD also showed that expression of the Ets2DBD increased the expression of Ets-dependent reporters (Figure 3b). Finally, a similar activation by the Ets2DBD was seen in the analysis of a potential Ets target gene p21<sup>cip</sup>, both in analysis of the endogenous p21<sup>cip</sup> gene, and in cotransfection experiments with a p21<sup>cip</sup> reporter

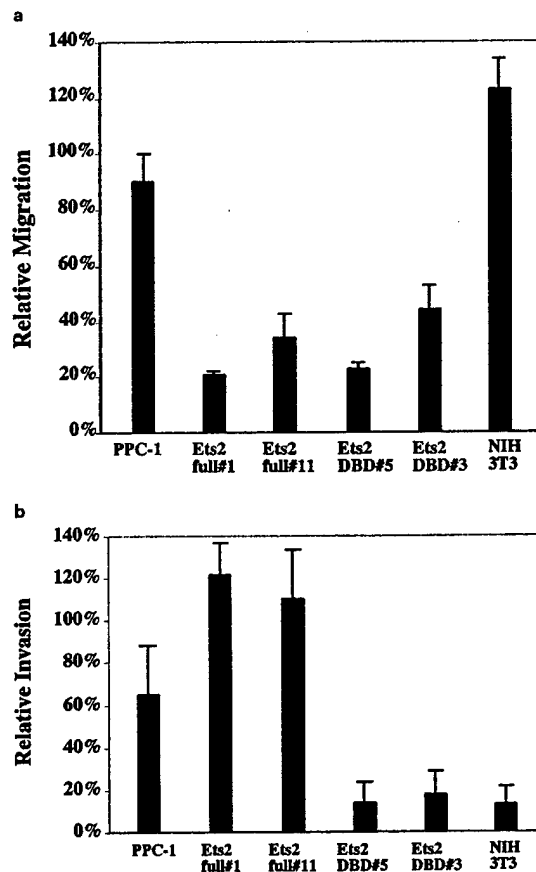


Figure 5 Effects of Ets2 or Ets2DBD on motility and invasion of PPC-1 cells. (a) Motility assay of the indicated stable PPC-1 clones, measuring the ability of cells to traverse uncoated filter inserts in 16 h. The migration rate of the pCIN#56 control cell line (which averaged 2000 cells/field) was defined as 100%, and the average relative migration rates of the indicated stable cell lines are shown. Values shown are the mean of triplicates from three different experiments. (b) *In vitro* invasion assays of the indicated stable PPC-1 clones were performed using invasion chambers coated with Matrigel, as described in Materials and methods. The invasion rate of pCIN#56 (which averaged 355 cells/field) was defined as 100%. The relative invasion rate of each indicated clone is shown, and represents the average of triplicates from three different experiments

(Figure 4b,c). This induction of p21<sup>cip</sup> expression by either Ets2 construct may be partially responsible for the reduced growth rate of PPC-1 cells expressing these constructs (Figure 1b). We have not yet identified essential Ets binding sites in the p21 promoter, but neither of the two previously characterized upstream overlapping Ets/p53 binding sites at approximately -2.2 kb and -1.3 k (Funaoka *et al.*, 1997; Beier *et al.*, 1999) are present in the 4-Luc reporter. In addition, PPC-1 cells are reported to contain only mutant p53 (Borner *et al.*, 1995), so interaction with p53 is an unlikely mechanism for the Ets2 constructs in regulating p21 expression in these cells. Possible mechanisms for transactivation by the Ets2 DNA binding domain alone, more pronounced in the synthetic E.36 and Py2 reporters, is that it acts by displacing Ets family transcriptional repressors (e.g. ERF, TEL, or NET), or that it binds DNA and recruits other activator proteins through protein-protein interactions. We are now investigating whether, unlike other cell types, PPC-1 cells or other prostate tumor cell lines have a functional predominance of Ets family repressor proteins.

The ability of prostate tumor cells to invade through basement membrane is a key component of their metastatic behavior. It is likely that Ets factors influence the expression of many metalloproteinases (MMPs) associated with invasiveness, as Ets binding sites are regulatory elements in the promoters of many of these MMP genes (reviewed in Crawford and Matrisian, 1996; Borden and Heller, 1997). Altered Ets activity has been reported to impair the motility or invasiveness of other cell types. Ets1 antisense oligonucleotides inhibited the motility and invasiveness of endothelial cells (Chen *et al.*, 1997), and expression of the Ets1DBD or Ets2DBD inhibited the migration and invasiveness of breast tumor cell lines (Sapi *et al.*, 1998; Delannoy-Courdent *et al.*, 1998). We show here that stable expression of the Ets2DBD resulted in a complete inhibition of the *in vitro* invasiveness of PPC-1 cells. This result was in sharp contrast to expression of full-length Ets2 in PPC-1 cells, which exhibited no inhibition of *in vitro* invasiveness (Figure 5). These results indicate that full-length Ets2 and the Ets2DBD do have some distinct biologically important targets in PPC-1 cells. We do not yet know the mechanism by which Ets2 or the Ets2DBD are differentially regulating target gene expression, but it may depend on promoter context. We are now undertaking several approaches to determine which of the many genes associated with invasiveness (e.g. MMPs, TIMPs, and integrins) exhibit altered expression in the various PPC-1 cell clones.

In summary, we have found that Ets factor activity can strongly influence the transformed and invasive phenotype of a human prostate tumor cell line. This novel linkage of Ets signaling to features such as the survival and invasiveness of a prostate tumor cell line, suggests that Ets proteins and the signaling pathways that control their activity may represent potentially useful targets for the treatment of prostate cancer. It will be of great interest to characterize the Ets target genes and the mechanisms by which they regulate the transformed phenotype of PPC-1 cells, and to determine the generality of these pathways in other prostate tumor cells.

## Materials and methods

### Cell growth and selection

The PPC-1 human prostatic carcinoma cell line was originally obtained from ATCC, and was cultured in RPMI 1640 media supplemented with 10% fetal calf serum (Gemini). The PPC-1 cells were transfected by the calcium phosphate method we previously described (Foos *et al.*, 1998), except that for a 10 cm dish, 10  $\mu$ g of pCIN-derived expression plasmid DNA and 10  $\mu$ g of high molecular weight herring testes carrier DNA were used. Stable colonies were selected 3 days after transfection using media containing 400  $\mu$ g/ml of active G418 (Calbiochem). Multiple isolated PPC-1 cell clones derived from each expression plasmid were randomly picked, expanded and passaged in the presence of 400  $\mu$ g/ml G418 for subsequent analysis.

### Ets2 expression plasmids

We have previously described the expression constructs for the FLAG epitope tagged Ets2 DNA binding domain (Ets2DBD) and the full-length Ets2 (Ets2full) in the pCIN4 vector (Foos *et al.*, 1998). The CMV-driven pCIN4 expression vector is a derivative of the pCIN plasmid (Rees *et al.*, 1996), and the Ets2 expression constructs in this vector express a bicistronic message encoding the inserted Ets2 coding sequences at the 5' end, an IRES, and then the NPT gene encoding G418 resistance.

### Attached colony and soft agar growth assays

Soft agar assays were essentially performed as previously described (Clark *et al.*, 1995) with 1000 cells plated in soft agar without G418. The soft agar plates were fed with 0.5 ml growth media every 3 days, and after 14 days, the cells were stained 14 h with the vital dye p-Iodonitroretrozolium violet (INT). Soft agar colonies visible without magnification were counted manually. In parallel to each soft agar assay, an attached growth assay was performed, where 400 cells from the same cell dilutions were plated in 50% standard growth media and 50% conditioned growth media on standard tissue culture dishes and grown for 7 days. Conditioned media was standard growth media in which ~30% confluent attached PPC-1 cells were grown for 24 h, which was then collected and sterile filtered. Attached colonies were stained with crystal violet and counted. The number of soft agar colonies for each cell line was then normalized by multiplying by the ratio (attached colonies from PPC-1 cells)/(attached colonies from the cell line) in the same experiment. The doubling times for the cell lines were determined by plating 2000 cells in quadruplicate plates, and then harvesting dishes after 24, 48, 72, or 96 h and counting the cells in a hemocytometer.

### Immunoblotting

Immunoblots were performed using whole cell extracts containing equal amounts of total protein. The FLAG epitope tagged Ets2 proteins were detected in immunoblots using the anti-FLAG M5 monoclonal antibody (Kodak). Analysis of the ratio of endogenous Ets2 to introduced Ets2 was performed by immunoblotting with the Ets2(C-20) antibody (Santa Cruz Biotechnology). Immunoblot signals were quantitated by imaging luminescence with Pierce Supersignal substrate, using a ChemImager (Alpha Innotech). The p21/p27 proteins were detected using anti-CIP/WAF and anti-Kip1/p27 (Transduction Laboratory) after immunoblotting extracts made from subconfluent cells. Both the anti-p21 and p27 antibodies gave the expected specific signals when used alone.

#### Apoptosis assays

For analysis of nuclear and cytoplasmic morphology, attached cells were washed with PBS, then stained with 4 µg/ml each of acridine orange and Ethidium Bromide in PBS. For the analysis of membrane inversion, the ANNEXIN-V-FLOUS kit (Boehringer-Mannheim) was used as recommended by the manufacturer. In brief, cells floating in the media and those removed from the dish with trypsin/EDTA were collected by centrifugation. The cells were resuspended in PBS, and then stained with propidium iodide and fluorescein conjugated Annexin V, and analysed by FACS (Becton Dickinson).

#### Reporter gene and RNase protection assays

We have previously described the minimal promoter-containing reporter plasmid Δ56fos-luc, and its Ets-responsive derivatives, E.36-luc and Py2-luc (Foos *et al.*, 1998). The p21<sup>EP</sup> reporters 0-luc and 4-luc contain the p21<sup>EP</sup> promoter sequences from -2326 to +16 or -883 to +16 respectively, fused to the luciferase coding sequence (Zeng *et al.*, 1997), and were generously provided by Dr WS El-Diery. Transfections for reporter gene assays were performed using Lipofectamine Plus (Gibco BRL) as recommended. In brief, 12-well dishes of 50% confluent cells were transfected using 0.03 µg of reporter plasmid and 0.45 µg of pCIN4-derived Ets2 expression constructs or the empty pCIN4 vector for each well. For each transfection, 5 µl PLUS reagent and 2.5 µl Lipofectamine were used. Sixteen hours following transfection, the growth media was replaced with media containing 0.5% calf serum, and the cells were incubated for an additional 6 h before harvest. Luciferase activity was quantitated using the Promega Luciferase Assay System and a Berthold Microlumet LB 96P luminometer. Transfection efficiency and non-specific effects were controlled as we previously described (Hauser *et al.*, 1995), by analysing multiple replicates, and the standard deviations are shown.

RNase protection assays were performed using the RPA II kit from Ambion as recommended by the manufacturer, and the results quantitated by phosphorimager. Templates to

generate control probes for human cyclophilin and GAPDH were also obtained from Ambion. Templates for human p21 and p27 RNase protection probes were generated by RT-PCR amplification of bases 150-345 and 34-269 of the p21 and p27 coding sequences respectively, which were then cloned into the pcDNA3 vector.

#### Invasion and motility assay

Biocoat Matrigel invasion chambers (Becton Dickinson Labware) were used to assess the invasiveness of the stable PPC-1 clones. Matrigel inserts (24-well format) were placed in wells containing 0.375 ml of standard growth media (RPMI+10% FCS) and 0.375 ml of the same media conditioned by NIH3T3 cells. Then 4 × 10<sup>4</sup> cells in 0.5 ml serum free RPMI media were added to the chambers and the plates were incubated for 24-36 h at 37°C, 5% CO<sub>2</sub>. Cells remaining on the upper filter surface were removed by scrubbing with cotton tipped swabs. The filter inserts were stained with crystal violet and all of the cells on the bottom of the filter were counted under 100× magnification. The relative invasion was calculated relative to the average invasion of the control pCIN#56 cells in the same triplicate experiment. The standard deviation was the variation of the relative means between three separate experiments. Motility assays were performed using Biocoat Control inserts, which contain uncoated eight micron pore filters. Motility assays were performed, quantitated, and analysed similar to the invasion assays, except that RPMI containing 10% fetal calf serum was used as the chemoattractant, and the cells stained after 16 h.

#### Acknowledgments

This work was supported by National Institutes of Health Grants CA63130 and CA74547, and a postdoctoral fellowship to G Foos from the US Army Medical Research and Material Command. We thank RG Oshima for helpful discussions, and C Galang for excellent technical assistance.

#### References

- Beier F, Taylor AC and LuValle P. (1999). *J. Biol. Chem.*, **274**, 30273-30279.
- Borden P and Heller RA. (1997). *Crit. Rev. Eukaryotic Gene Expression*, **7**, 159-178.
- Borner MM, Myers CE, Sartor O, Sei Y, Toko T, Trepel JB and Schneider E. (1995). *Cancer Res.*, **55**, 2122-2128.
- Brothman AR, Lesho LJ, Somers KD, Wright Jr GL and Merchant DJ. (1989). *Int. J. Cancer*, **44**, 898-903.
- Brothman AR, Wilkins PC, Sales EW and Somers KD. (1991). *J. Urol.*, **145**, 1088-1091.
- Chen TR. (1993). *Cytogen. Cell Gen.*, **62**, 183-184.
- Chen G, Branton PE and Shore GC. (1995). *Exper. Cell Res.*, **221**, 55-59.
- Chen Z, Fisher RJ, Riggs CW, Rhim JS and Lautenberger JA. (1997). *Cancer Res.*, **57**, 2013-2019.
- Clark GJ, Cox AD, Graham SM and Der CJ. (1995). *Methods Enzymol.*, **255**, 395-412.
- Crawford HC and Matrisian LM. (1996). *Enzyme. Protein*, **49**, 20-37.
- Delannoy-Courdent A, Mattot V, Fafeur V, Fauquetté W, Pellet I, Calmels T, Vercaemer C, Boilly B, Vandenbunder B and Desbiens X. (1998). *J. Cell Sci.*, **111**, 1521-1534.
- Dittmer J and Nordheim A. (1998). *Biochim. Biophys. Acta*, **1377**, F1-F11.
- Foos G, García-Ramírez JJ, Galang CK and Hauser CA. (1998). *J. Biol. Chem.*, **273**, 18871-18880.
- Funaoka K, Shindoh M, Yoshida K, Hanzawa M, Hida K, Nishikata S and Fujinaga K. (1997). *Biochem. Biophys. Res. Commun.*, **236**, 79-82.
- Galang CK, Der CJ and Hauser CA. (1994). *Oncogene*, **9**, 2913-2921.
- Galang CK, Garcia-Ramirez J, Solski PA, Westwick JK, Der CJ, Neznanov NN, Oshima RG and Hauser CA. (1996). *J. Biol. Chem.*, **271**, 7992-7998.
- Ghysdael J and Boureux A. (1997). The Ets family of transcriptional regulators. *Oncogenes as Transcriptional Regulators, Vol. 1: Retroviral Oncogenes*. Yaniv M and Ghysdael J (eds). Birkhäuser Verlag: Basel, pp. 29-88.
- Graves BJ and Petersen JM. (1998). *Advances in Cancer Research*, **75**, 1-55.
- Gumerlock PH, Poonamallee UR, Meyers FJ and de Vere White RW. (1991). *Cancer Res.*, **51**, 1632-1637.
- Hauser CA, Westwick JK and Quilliam LA. (1995). *Meth. Enzymol.*, **255**, 412-426.
- Huang CC, Papas TS and Bhat NK. (1997). *Oncogene*, **15**, 851-856.
- Huncharek M and Muscat J. (1995). *Cancer Epidemiol., Biomarkers Prev.*, **4**, 681-687.
- Konishi N, Hiasa Y, Tsuzuki T, Tao M, Enomoto T and Miller GJ. (1997). *Prostate*, **30**, 53-57.
- Kurada P and White K. (1998). *Cell*, **95**, 319-329.

- Langer SJ, Bortner DM, Roussel MF, Sherr CJ and Ostrowski MC. (1992). *Mol. Cell. Biol.*, **12**, 5355-5362.
- Li RH, Pei HP and Papas T. (1999). *Proc. Natl. Acad. Sci. USA*, **96**, 3876-3881.
- Liu AY, Corey E, Vessella RL, Lange PH, True LD, Huang GM, Nelson PS and Hood L. (1997). *Prostate*, **30**, 145-153.
- McCarthy SA, Chen D, Yang B-S, Garcia-Ramirez JJ, Cherwinski H, Chen X-R, Klagsbrun ML, Hauser CA, Ostrowski MC and McMahon M. (1997). *Mol. Cell. Biol.*, **17**, 2401-2412.
- Rees S, Coote J, Stables J, Goodson S, Harris S and Lee MG. (1996). *Biotechniques*, **20**, 102-110.
- Royai R, Lange PH and Vessella R. (1996). *Semin. Oncol.*, **23**, 35-40.
- Sapi E, Flick MB, Rodov S and Kacinski BM. (1998). *Cancer Res.*, **58**, 1027-1033.
- Schneikert J, Peterziel H, Defossez PA, Klocker H, Launoit Y and Cato AC. (1996). *J. Biol. Chem.*, **271**, 23907-23913.
- Sementchenko VI, Schweinfest CW, Papas TS and Watson DK. (1998). *Oncogene*, **17**, 2883-2888.
- Sevilla L, Aperlo C, Dulic V, Chambard JC, Boutonnet C, Pasquier O and Boulukos KE. (1999). *Mol. Cell. Biol.*, **19**, 2624-2634.
- Shao NS, Chai YL, Cui JQ, Wang N, Aysola K, Reddy ESP and Rao VN. (1998). *Oncogene*, **17**, 527-532.
- Shi XB, Gumerlock PH and de Vere White RW. (1996). *World J. Urol.*, **14**, 318-328.
- Suzuki H, Romano-Spica V, Papas TS and Bhat NK. (1995). *Proc. Natl. Acad. Sci. USA*, **92**, 4442-4446.
- Wasilenko WJ, Palad AJ, Somers KD, Blackmore PF, Kohn EC, Rhim Jr. JS and Schellhammer PF. (1996). *Int. J. Cancer*, **68**, 259-264.
- Wasylyk B, Hagman J and Gutierrezhartmann A. (1998). *Trends Biochem. Sci.*, **23**, 213-216.
- Wasylyk C, Flores P, Gutman A and Wasylyk B. (1989). *EMBO J.*, **8**, 3371-3378.
- Wasylyk C, Maira SM, Sobieszczuk P and Wasylyk B. (1994). *Oncogene*, **9**, 3665-3673.
- Webber MM, Bello D and Quader S. (1997). *Prostate*, **30**, 58-64.
- Woods D, Parry D, Cherwinski H, Bosch E, Lees E and McMahon M. (1997). *Mol. Cell. Biol.*, **17**, 5598-5611.
- Yamada T, Kondoh N, Matsumoto M, Yoshida M, Maekawa A and Oikawa T. (1997). *Blood*, **89**, 1383-1393.
- Yang B-S, Hauser CA, Henkel G, Colman MS, Van Beveren C, Stacey KJ, Hume DA, Maki RA and Ostrowski MC. (1996). *Mol. Cell. Biol.*, **16**, 538-547.
- Zeng YX, Somasundaram K and Eldeiry WS. (1997). *Nature Genet.*, **15**, 78-82.
- Zhang M, Magit D and Sager R. (1997). *Proc. Natl. Acad. Sci. USA*, **94**, 5673-5678.

# **Ras Signaling to Transcription Activation: Analysis With GAL4 Fusion Proteins**

Gabriele Foos<sup>1</sup>, Christina K. Galang<sup>1</sup>, Chao-Feng Zheng<sup>2</sup>, and Craig A. Hauser<sup>1</sup>

1. La Jolla Cancer Research Center, The Burnham Institute, 10901 North Torrey Pines Rd., La Jolla, CA 92037, USA
2. Stratagene Cloning Systems, 11011 North Torrey Pines Road, La Jolla, CA 92037, USA.

Running title: Transcription activation assays with GAL4 fusions.

Correspondence to:

Craig A. Hauser  
La Jolla Cancer Research Center  
The Burnham Institute  
10901 North Torrey Pines Rd.  
La Jolla, CA 92037  
Tel: (619) 646-3119;  
Fax: (619) 646-3192  
E-mail: CHauser@LJCRF.edu

**Introduction.** Activation of Ras signaling stimulates multiple downstream signaling cascades, many of which ultimately converge on the nucleus and broadly alter cellular gene expression. These widespread changes in gene expression are important for regulating normal growth, and when aberrantly regulated, for mediating oncogenesis. Many of the changes in gene expression mediated by Ras are the result of signaling through multiple parallel pathways resulting in activation of MAP kinase family members<sup>1,2</sup>. These activated MAP kinases then translocate to the nucleus and phosphorylate transcription factors, which can greatly increase their transactivation activity<sup>3</sup>. Reporter genes have been of great use in understanding both Ras signal transduction and its targets. There are several different methods utilizing reporter genes to analyze Ras signaling, and these approaches address distinct questions. One approach is to transiently cotransfect oncogenic Ras and a reporter construct consisting of the promoter region of the gene fused to an easily assayed reporter coding sequence (e.g. luciferase). This approach is useful for monitoring how the complex promoter elements of a particular gene together respond to Ras to regulate its transcription. Another reporter gene approach for analyzing how Ras alters the activity of a particular type of transcription factor, is transient cotransfections of Ras with a reporter construct consisting of synthetic binding sites for the transcription factor inserted into a minimal promoter-reporter. We have previously described the methods of this approach in detail<sup>4</sup>, and have used it to show that Ets transcription factors are targets of Ras signaling<sup>5</sup>. It is important to note that most transcription factors are part of large families that bind similar promoter sequences. Thus, unless one can observe "superactivation" by cotransfection of Ras and an expression construct for the specific transcription factor<sup>6</sup>, such reporters with synthetic binding sites may actually measure overall changes in the activity of the transcription factor family.

The type of reporter gene analysis described in this chapter, utilizes fusion proteins between a heterologous DNA binding domain from yeast GAL4, and the transactivation domain of a specific transcription factor. The transcriptional activity of the hybrid transcriptional activator is monitored by cotransfection with a reporter gene containing multiple GAL4 DNA binding sites in front of a

minimal promoter and luciferase coding sequence. This approach allows one to analyze Ras-induced changes in the transactivation activity of a specific transcription factor, independent of its normal DNA binding activity or the level of the endogenous factor expression. Mutational analysis of the transactivation domain present in the fusion protein can be further used to define the residues involved in mediating Ras-responsiveness. In addition, this type of reporter gene system is extremely useful as a downstream readout to study how different proteins or pharmacological agents alter specific Ras signal transduction pathways. For example, stimulation of the ERK, JNK, or p38 MAPK pathways have been monitored using GAL4-Elk, GAL4-Jun, or GAL4-CHOP reporters, respectively <sup>7-9</sup>.

**General Considerations.** Overall, this type of reporter gene analysis involves transient cotransfection of two or three different plasmids into an appropriate cell line. These plasmids are the expression construct for the GAL4 DNA binding domain fused to a transactivation domain (e.g. GAL4-Elk), a reporter gene with multiple GAL4 DNA binding sites preceding a minimal promoter fused to the luciferase coding sequence (e.g. pFR-Luc), and if desired, an expression construct for an activated signaling molecule (e.g. pZIPrasH(61L) which expresses oncogenic Ras). If the altered signaling ultimately stimulates phosphorylation of the transactivation domain in the hybrid transcription factor, then transcription of the luciferase reporter gene is activated. This approach is schematically shown in Fig. 1. Two days after transfection, the cells are harvested and the luciferase activity then quantitated. While such assays are quite simple and rapid to perform, care must be taken in including appropriate controls. Thus, below we describe the methods for inexpensive, high throughput analysis of transcriptional signaling using GAL4 fusion proteins, and discuss the considerations for setting up and interpreting these assays.

### ***Cell Type and Growth Conditions***

The selection of a cell line to use depends on the specific regulation being analyzed. Different cell lines can have quite different signaling components, which can greatly affect the outcome of the

GAL4 fusion activator assay. Because we have been studying the role of transcriptional signaling in cellular transformation using an NIH3T3 cell model, we have utilized these cells for a number of studies. While the transfection efficiency of different cell lines can vary a great deal, nearly 100% of the cells that are transiently transfected get all of the plasmids in the transfection mix. Thus, even in poorly transfecting cell lines, it is reasonable to assume that every cell that expresses the luciferase reporter also is expressing the GAL4 fusion protein and the activated signaling protein. Cell lines that are difficult to transfect may require lipid-mediated transfection or electroporation. However, for NIH3T3 cells, a substantial signal is obtained using the simple calcium phosphate method described below on cells plated in 12-well dishes. To avoid obscuring potential regulatory mechanisms by constantly stimulating the cells with serum growth factors, after the transfection, it is often useful to starve the cells for the final 24 hours of the assay. The composition and preparation of media and buffers used were previously described in detail <sup>4</sup>, but the procedure below has been modified for 12 well dishes, with NIH3T3 cells.

NIH3T3 cells are grown at 37° in a humidified 5% CO<sub>2</sub> incubator, in DMEM containing 10% calf serum, 2 mM glutamine, and 100 units/ml of streptomycin and penicillin. The day before transfection, split the cells to approximately 30% confluent, which is  $1 \times 10^5$  cells/4 cm<sup>2</sup> well of a 12-well dish. For this split, cells from 10 cm stock dishes are removed with trypsin, resuspended by pipetting up and down several times with an equal volume of growth media, then suspended in growth media at  $1 \times 10^5$  cells / ml in 50 ml sterile tubes (A fairly dense 10 cm stock plate will yield about 70 wells). After thoroughly mixing the cell suspension by inverting, transfer 1 ml of cell suspension to each well of a 12 well plate. This large volume pooling of the cells prior to plating helps insure a constant number of cells in each well. To get even attachment of the cells, rock and swirl the plates well before placing them on a level incubator shelf. We have found that there is usually sufficient luciferase signal to transfect and assay even smaller wells (e.g. 24 well plates), but these have increased "edge effects" causing uneven cell plating and less reproducible transfections. On the other hand, it should be noted that for the standard assay, transfecting larger

plates or dishes will not increase the luciferase signal, as a proportionally larger amount of cell lysis buffer will be needed to make cell extract.

## Plasmids

Since the original observation that the DNA binding and transactivation activities of transcription factors can be found in separable structural domains was made with yeast GAL4<sup>10</sup>, the GAL4 DNA binding domain/nuclear localization signal (residues 1-147) has been used to generate numerous chimeric transcription factors<sup>11</sup>. Reporter genes containing 5 GAL4 binding sites, the E1b minimal promoter<sup>7</sup>, and the luciferase coding sequence, have also been widely used. The oncogenic Ras expression construct used in our experiments was pZIPrasH(61L)<sup>12</sup>. One can obtain specific GAL4 fusion transcription factors and the reporter gene from the many investigators who have reported their use, or purchase an assortment of them from Stratagene. Stratagene sells the "PathDetect Trans-Reporting Systems", including mammalian expression constructs for GAL4 fusions with Elk1, Jun, CHOP, CREB, ATF2, and Fos. In addition, they also can provide the GAL4 binding site-containing luciferase reporter gene (pFR-Luc) and several different expression constructs for activated components of the Ras signaling pathway, including the ones used in this work, the CMV-driven pFC-MEKK (MEKK residues 380-672), pFC-MEK1\* (MEK1 S218/222E, Δ32-51), and pFC-PKA (the PKA catalytic subunit).

### *Transient Transfection of NIH3T3 Cells Grown in 12 Well Plates.*

#### *Stock Solutions for Transfection*

2x HBS: 1.64% NaCl (w/v), 1.19% HEPES (w/v), 0.06% Na<sub>2</sub>HPO<sub>4</sub> (w/v). Adjust to pH 7.12 with 1 N NaOH, filter sterilize and store at 4°.

2.5 M CaCl<sub>2</sub>: (A 10x stock) Dissolve tissue culture grade CaCl<sub>2</sub> in distilled H<sub>2</sub>O, filter sterilize, and store at -20°C.

Calf Thymus Carrier DNA Dried "highly polymerized" calf thymus DNA (Cat. No. D 1501, Sigma, St. Louis, MO) is suspended in TE (10 mM Tris pH 7.8, 0.1 mM EDTA) at 5 mg/ml and

then incubated overnight at 60° to aid in resuspension. The DNA is then ethanol precipitated and resuspended as above in sterile TE at about 4 mg/ml. The actual concentration of the slightly viscous carrier DNA is measured with a spectrophotometer, and aliquots are stored at 4°. We formerly used herring testis DNA (Sigma Cat No. 6898), but several recent batches of this product appear to be lower molecular weight DNA, and are 10-fold less efficient in potentiating transient transfection than the previous batches or the current calf thymus DNA.

Plasmid DNAs were prepared by Qiagen columns (Qiagen Inc., Chatsworth, CA) as recommended by the manufacturer.

Three hours prior to transfection, draw off the media and feed the cells with 1 ml warm media containing 10% calf serum. For a typical transfection, add to a sterile microfuge tube: 62.5 µl of 0.25 M CaCl<sub>2</sub> containing 0.5 µg reporter construct (e.g. pFR-luc), 10-50 ng of GAL4 fusion construct (e.g. GAL4-Elk), 0.5 µg of oncogenic Ras expression construct [e.g. pZIPrasH(61L)], and calf thymus carrier DNA to a total of 5 µg DNA. We do not typically make adjustments in the amount of calf thymus DNA for small differences in the amount of plasmid DNA, so a starting cocktail of 0.25 M CaCl<sub>2</sub> with 4.0 µg carrier DNA and 0.5 µg pFR-luc/62.5 µl is used. To another set of microfuge tubes, add 62.5 µl 2X HBS. Then, while vortexing the open microfuge tube with the 2x HBS, add the contents of the DNA-containing tube dropwise to this tube over the course of about 10 sec. The dropwise addition is somewhat laborious, but makes transfection more reproducible. Enhanced reproducibility is particularly important for analysis with GAL4 fusion activators, with which we see substantially more assay variability than with standard reporter genes. This is the case even when the GAL4 fusion constructs have been properly diluted to assure accurate addition of the nanogram amounts of DNA used for transfection.

Let the precipitate stand for about 20 min. It should look cloudy and may be somewhat granular. Vortex each tube again prior to pipetting the precipitate onto the cells and then swirl the media on

the plate. For optimal precipitate formation, the components should be at room temperature. Mixing of the DNAs, precipitation, and addition of precipitate to the cells is routinely performed on the lab bench, without subsequent problems with contamination. Approximately 16 hours after transfection, the media is drawn off, the cells are washed once with 1 ml warm PBS containing 0.2 mM EGTA. The inclusion of EGTA in the wash is not essential with NIH3T3 cells, but it can raise the transfection efficiency by reducing the calcium precipitate toxicity seen in more sensitive cell lines. After the wash, 1 ml of growth media containing only 0.5% calf serum is added to each well, and the cells are incubated for an additional 24 hr prior to harvest for the luciferase assay. This serum starvation is not always essential, but it can greatly reduce basal level signals in serum-sensitive pathways.

### *Luciferase assay*

#### *Stock Solutions for Luciferase assay*

Cell Lysis Solution 20 mM Tris pH 7.8, 0.2% Triton X-100, 1 mM DTT. In our hands, Tris works better than potassium-containing buffers in the lysis and assay buffers.

250 mM ATP Solution: Dissolve ATP (Pharmacia Cat. No. 27-1006-03) in H<sub>2</sub>O. Adjust pH to 7.0 with concentrated NH<sub>4</sub>OH. Store at -20°.

10 mM Luciferin Solution: D-Luciferin-potassium salt (Cat. No. 1600, Analytical Luminescence Laboratory). Store at -20°C protected from light.

Luciferase Assay Mix 20 mM Tris pH 7.8, 9.3 mM ATP, 14.2 mM MgSO<sub>4</sub>, 66 nM luciferin

The following procedure was developed for use with a microplate luminometer equipped with a 100µl injector. We use a Berthold EG&G LB 96 P luminometer linked to a Macintosh computer. While one can use a single-tube luminometer, and they may be more sensitive to weak signals, there is a tremendous gain in throughput and a savings in labor and reagent costs using a microplate luminometer. A microplate luminometer can read 96 assays unattended in about 30 min, and can provide the results as a Microsoft Excel file. Regarding assay cost, commercial

luciferase assay kits such as that from Promega (Madison, WI) are excellent when very high sensitivity and extended glow are needed. However, the assay described below works well very with easily transfected cells, and at a cost of ~4¢/ well, is about 10-fold less expensive than using commercial kits.

Wash cells twice with PBS. Thoroughly remove the PBS from the last wash by aspiration, and after keeping the 12 well dish tilted for a few seconds, aspirating each well again. Add 150 µl Cell Lysis Solution to each well. The cells will often detach and lyse by themselves, or after a sharp hit of the lysis buffer-containing plate. If not, remove by scraping, and transfer the liquid to a microfuge tube. Spin for 2 minutes at RT to pellet any debris. Transfer supernatant to a new tube. These cell extracts may be assayed immediately or frozen at -70°C for future assay. Transfer 100 µl of extract to a white microtiter plate (e.g. Corning Costar #3912). One should include several wells of just cell lysis buffer for background determination. Prepare Luciferase Assay Mix (100 µl per assay plus a sufficient quantity to prime the injector and for blank wells) in foil-wrapped tube. Wash and prime the luminometer injector as recommended by the manufacturer - we wash with 60 injections of H<sub>2</sub>O followed by priming with 12 injections of luciferase assay mix. Failure to prime the injector with luciferase assay buffer will cause a loss of signal in the first several assay wells. The assay is carried out using a 100 µl injection of luciferase assay buffer, followed by a 10 sec integration with no delay. With our instrument, the background is about 120 RLU, and the signal is linear to over 5 million RLU.

*Use of GAL4 constructs to analyze Ras activation of a transcription factor.*

We previously found that phosphorylation of Ets2 T72 is necessary for the large increase in Ets2 activity mediated by oncogenic Ras or Neu<sup>6,13</sup>. An example of using GAL4 constructs to analyze the effect of Ras on Ets2 transactivation activity is shown in Figure 2A. GAL4-Ets2 fusion constructs were made using an HA-epitope tagged derivative of the Stratagene pFC-dbd vector (see below). We found that GAL4-Ets2(1-172) was strongly activated by oncogenic Ras in the reporter

gene assay system. The Ets2 T72A mutation in this context caused a modest reduction of the basal transactivation activity, but Ras-mediated activation was reduced to background levels seen with the empty GAL4 vector. Triple glycine substitution at the indicated residues of GAL4-Ets2(1-172) disrupted both the apparent basal transactivation activity and Ras activation (Figure 2A).

Titration experiments with GAL4-Ets2(1-172) plasmid, as well as with all the other GAL4 fusion activators that we have tested, consistently show that transfecting very small amounts of the expression construct for the GAL4 hybrid transcription factor gives the best results for activation by Ras and other signaling molecules. In this example, only 20 ng of the GAL4-Ets2(1-172) was cotransfected to obtain maximal activation with the pFR-luc reporter gene and the oncogenic Ras expression construct pZIPrasH(61L). If substantially more GAL4 construct is used (e.g. 100 ng), the basal level of expression of the pFR-luc reporter (that seen when cotransfected with the empty pZIP expression plasmid) is quite high, and coexpression of oncogenic Ras has little additional effect (data not shown). This is not a consequence of exceeding the linear range of the luciferase assay, but instead seems to involve titration of limiting cellular factors required for activation. While the amount of GAL4 construct used must be determined empirically, a general guide is to use between 5-100 ng and to use the least amount possible that gives a reliable basal signal.

#### *Controls for the transactivation assays*

We have not observed significant transcriptional activity of the GAL4 dbd parental vector (e.g. pFC-dbd), but this is necessary to confirm in each cell line tested. An internal control plasmid is not included in our cotransfection assays, but instead we rely on parallel control experiments and sufficient repetition in separate experiments to normalize for changes caused by experimental variation. Internal control plasmids can introduce new problems, as addition of a fourth cotransfected plasmid (e.g. CMV- $\beta$ -gal) can act as a transcriptional competitor, and can itself also be Ras-responsive. If an internal control plasmid is desired, a non-Ras-responsive control reporter

expressing Renilla luciferase (which can be separately be assayed from firefly luciferase) has been described<sup>14</sup>.

Typically, to generate solid data, experiments are repeated three different times in duplicate. The duplicates should be separately precipitated and transfected DNAs, as this is the major source of variation within each experiment. There can be significant variation in the absolute value of luciferase signals obtained on different days, and thus the data from different experiments are often best combined when expressed as "fold activation" within each experiment by Ras or other signaling components being tested. This approach leads to good reproducibility. Other approaches to normalize experiments such as expressing the data as RLU/mg protein are also used, but the majority of the variation seems to arise from different levels of transfection efficiency between experiments. We have not found it of value to normalize the luciferase data to the amount of protein in each extract, as using the pooled plating, transfection and direct lysis procedure described here, there is rarely significant variation in extract protein content.

One important control for the experiment shown in Figure 2A is to confirm that the abundance of the GAL4-Ets2 construct is not substantially altered either by expression of oncogenic Ras or by changes in protein stability from mutations in the Ets2 portion. As mentioned above, increasing the amount of GAL4 fusion activator can strongly increase reporter gene expression, and such a change could be misinterpreted as a Ras-mediated increase in transactivation activity. One source of problems can be the use of a GAL4 fusion construct expression vector that contains a Ras-responsive promoter. Our experience is that SV40-driven GAL4 construct vectors such as the original pFC-dbd (Stratagene) are not Ras-responsive, whereas the CMV-driven pFC2-dbd (Stratagene), like other CMV driven constructs, is quite Ras-responsive (CKG and CAH unpublished data). To compare both the basal and Ras-induced transactivation activity of various GAL4-Ets2 constructs, it is important to determine that truncations and mutations in Ets2 are not altering the hybrid protein stability. This presents a difficult technical problem, as the 20 ng of

CaPO<sub>4</sub> transfected GAL4-Ets2 plasmid DNA transfected cells is expressed at levels well below the threshold of detection by immunoblotting. However, an estimate can be made of the relative protein expression and stability, using a parallel experiment of lipid-mediated transfection with substantially more plasmid DNA (e.g. 0.5 µg) under otherwise analogous conditions. This control is not ideal, but it allows one to determine whether there are large changes in the steady-state levels of GAL4 fusion protein under related conditions.

Even after scaling up transfections, it can be difficult to obtain an immunoblot signal for the GAL4 fusion proteins. Two different commercial antibodies against the GAL4 DBD gave us weak signals with the GAL4-Ets2 as well as other GAL4 fusions. Thus, we generated an HA epitope-tagged GAL4-dbd expression construct from pFC-dbd, with 4 HA tags at its N-terminus. This SV40-driven construct, p4HACH, has the same cloning sites as pFC2-dbd, allowing a rapid transfer of Ets2 sequences to this context. Transactivation studies showed that the p4HACH-Ets2 constructs behaved the same as the previously tested pFC-dbd-Ets2 constructs (GF and CAH, unpublished data). Immunoblot analysis of GAL4 construct expression using an anti-HA monoclonal antibody, revealed that Ras was not inducing GAL4-Ets2(1-172) expression (Figure 2B, lanes 6 and 7). In addition, this analysis showed that similar amounts of each GAL4-Ets2(1-172) protein were present in uninduced conditions, with the exception of the G(122-124) mutant (Fig. 2B, lane 4). The instability of this mutant protein, also observed in several other experiments, means that one can not conclude that the loss of basal and Ras-induced activity of the G(122-124) construct (Fig. 2A) was due to altered transactivation activity. This example of an unstable fusion protein highlights the fact that without adequate controls, one can not assume that the GAL4 fusion activator system provides a direct readout of transactivation activity.

#### *Use of GAL4 constructs to monitor Ras signal transduction*

An example of an initial experiment to examine signaling pathway activation using a variety of GAL4 fusion activators in NIH3T3 cells is shown in Table I. Some of these results are as

expected, such as Ras and MEK activation of GAL4-Elk, and modest PKA activation of GAL4-CREB. It is informative to note the difference in the results obtained with the two similar GAL4-Elk constructs, as the only difference between them is that one is expressed using the SV40 promoter, and the other (denoted in Table I by "pFC2") from the CMV promoter. We have found that the huge increase of pFC2GAL4-Elk activity by Ras, MEKK, or MEK, is due to the combination of a substantial increase in the expression of the GAL4-ELK protein, as well as increases in its transcriptional activation. We have further observed that MEKK even activates expression from the SV40 promoter, causing false readouts of increased transactivation. This altered GAL4 fusion construct expression complicates the analysis, and also highlights the need to measure protein levels. When working with activators such as Ras that can act across several signaling pathways, it is useful to find control GAL4 fusion activators that have significant basal transactivation activity, but whose transactivation activity is not affected by Ras signaling. This provides a valuable parallel negative control for Ras-mediated activation. The GAL4-VP-16 fusion is the best such control that we have found, as its strong basal signal with the pFR-Luc reporter is not altered by coexpression of oncogenic Ras (Table I and data not shown). The finding that MEK1 expression can activate GAL4-Jun (Table I), likely reflects an autocrine loop similar to that reported with Raf activation of JNK <sup>15</sup>.

Both the specificity and magnitude of reporter gene response can be affected by the choice of the cell line assayed. These same plasmid constructs in HeLa cells showed more specificity when tested with the same activated MEKK, MEK1, and PKA constructs. In the HeLa cells, GAL4-Jun was activated by MEKK but not MEK, GAL4-Elk activated by MEKK and MEK1, and GAL4-CREB activated only by PKA <sup>16</sup>. It is interesting to note that while GAL4-cJUN was not strongly activated by MEKK in NIH3T3 cells, it was strongly activated in several other cell lines including HeLa, 293, and CHO cells (CFZ, unpublished data). Overall, GAL4 fusion reporter gene systems are a powerful way to analyze signaling, but because of the complexity and cross-talk involved in Ras signaling <sup>17</sup>, one must not rely solely on this approach. Complementary approaches for

monitoring downstream signaling, such as MAP kinase assays, are described elsewhere in this volume.

**Acknowledgements** This work was supported by NIH grants CA63130 and CA74547 to CAH. GF is supported by a postdoctoral grant from the USAMRMC.

## References

1. M.H. Cobb, *Progress in Biophysics & Molecular Biology* **71**, 479 (1999).
2. T.S. Lewis, P.S. Shapiro and N.G. Ahn, *Advances in Cancer Research* **74**, 49 (1998).
3. R. Treisman, *Current Opinion in Cell Biology* **8**, 205 (1996).
4. C.A. Hauser, J.K. Westwick and L.A. Quilliam, *Methods Enzymol.* **255**, 412 (1995).
5. C.K. Galang, C.J. Der and C.A. Hauser, *Oncogene* **9**, 2913 (1994).
6. B.-S. Yang, C.A. Hauser, G. Henkel, M.S. Colman, C. Van Beveren, K.J. Stacey, D.A. Hume, R.A. Maki and M.C. Ostrowski, *Mol. Cell Biol.* **16**, 538 (1996).
7. R. Marais, J. Wynne and R. Treisman, *Cell* **73**, 381 (1993).
8. T. Smeal, M. Hibi and M. Karin, *EMBO Journal* **13**, 6006 (1994).
9. X.Z. Wang and D. Ron, *Science* **272**, 1347 (1996).
10. J. Ma and M. Ptashne, *Cell* **48**, 847 (1987).
11. I. Sadowski and M. Ptashne, *Nucleic Acids Research* **17**, 7539 (1989).
12. C.J. Der, B. Weissman and M.J. MacDonald, *Oncogene* **3**, 105 (1988).

13. C.K. Galang, J. Garcia-Ramirez, P.A. Solski, J.K. Westwick, C.J. Der, N.N. Neznanov, R.G. Oshima and C.A. Hauser, *J.Biol.Chem.* **271**, 7992 (1996).
14. G. Behre, L.T. Smith and D.G. Tenen, *Biotechniques* **26**, 24 (1999).
15. S.A. McCarthy, M.L. Samuels, C.A. Pritchard, J.A. Abraham and M. McMahon, *Genes Dev.* **9**, 1953 (1995).
16. L. Xu, T. Sanchez and C.-F. Zheng, *Stratagies* **10**, 1 (1997).
17. S.L. Campbell, R. Khosravi-Far, K.L. Rossman, G.J. Clark and C.J. Der, *Oncogene* **17**, 1395 (1998).

## Figure and table legends.

**Figure 1. Analysis of Ras activation of Elk-1 with GAL4-ELK1 fusion and luciferase reporter construct.** Shown on the top of the figure are schematic representations of the plasmids used. pFA-Elk1 expresses a fusion protein of GAL4 DNA binding domain activation domain of the ternary factor Elk1. The plasmid pFC-Ras is an expression vector for oncogenic human Ha-Ras (61L). The pFR-Luc reporter plasmid expresses luciferase when GAL4-Elk1 fusion factor is activated in mammalian cells. 1) Cotransfection of the reporter plasmid (pFR-Luc), fusion transactivator plasmid (pFA-Elk1) and the expression vector for the gene of interest (pFC-Ras) into mammalian cells such as NIH3T3 or HeLa cells with calcium phosphate or lipid-mediated methods. 2) In the transfected cells, pFC-Ras expresses activated Ras protein which causes the sequential activation of protein kinases Raf, MEK, and then the MAP kinases ERK1/2 in the cytoplasm. 3) Activated MAP kinase translocates into the nucleus and phosphorylates GAL4-Elk1, which is being constitutively expressed in the nucleus from pFA-Elk1. Phosphorylated GAL4-Elk1 then becomes transcriptionally active, stimulating the transcription of the luciferase gene on the pFR-Luc plasmid. Therefore, luciferase activity in transfected cells reflects the activation status of MAP kinases and the upstream components of the Ras pathway.

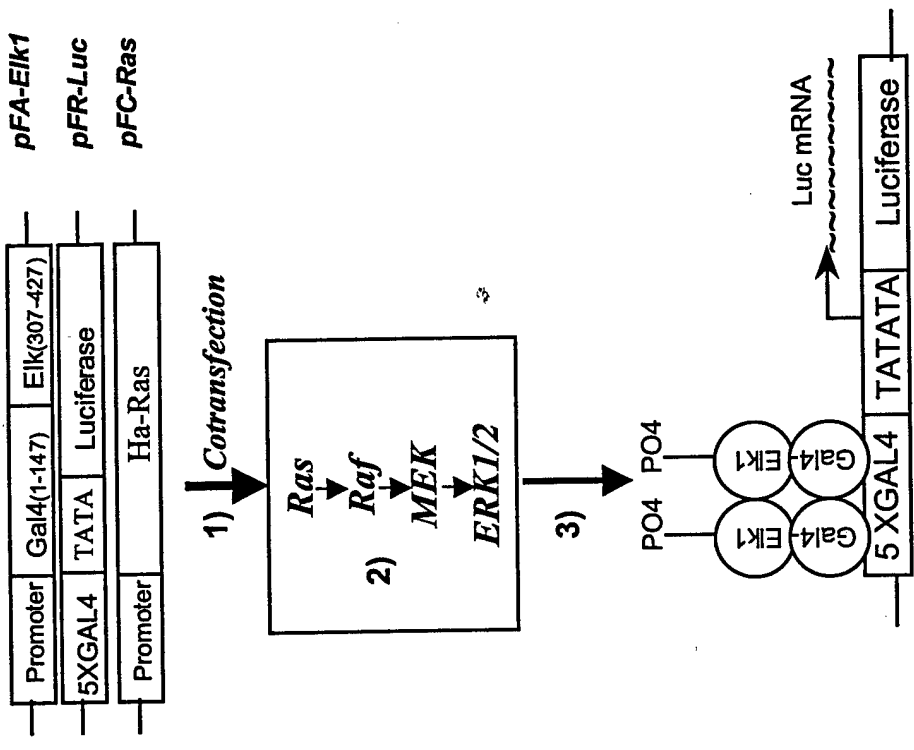
## Figure 2. Analysis of Ras-mediated transactivation using GAL4-Ets2 constructs.

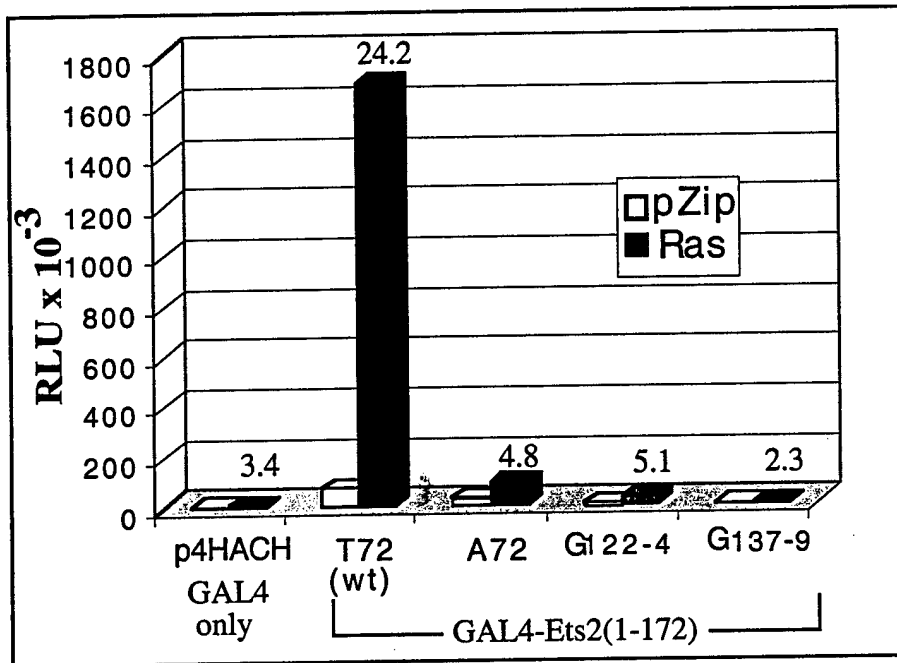
**A.** Results of a representative transactivation assay. NIH3T3 cells were transfected in 12 well dishes using the calcium phosphate method. Each well received 0.5  $\mu$ g of pFR-Luc reporter, 0.5  $\mu$ g of either pZIPrasH(61L) (black bars) or the empty pZIP expression vector (white bars), 20 ng of the indicated GAL4-Ets2 construct, and 4  $\mu$ g of calf thymus DNA. The cells were starved for 24 hr prior to harvest and assayed as described in the text. The fold increase in luciferase activity mediated by Ras for each construct is shown above the black bars. **B.** Immunoblot of GAL4-Ets2 fusion proteins with an antibody directed against the HA epitope tag. Each well on a 12 well dish of NIH3T3 cells was cotransfected with 0.5  $\mu$ g of the indicated GAL4-Ets2(1-172) expression construct (except lane 1), and 0.5  $\mu$ g of pZIP (lanes 1-6) or 0.5  $\mu$ g of pZIPrasH(61L) (lane 7),

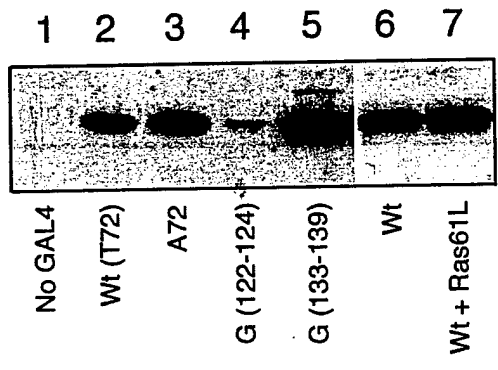
using lipofectamine (Gibe/BRL). The cells were then grown as in the reporter gene assay, harvested by scraping, washed, and resuspended in 20  $\mu$ l loading buffer. Then 10  $\mu$ l of each extract subjected to SDS PAGE, transferred to nitrocellulose, probed with a monoclonal antibody against the HA epitope, and antibody binding visualized using the Pierce Supersignal reagents.

**Table I. Effects of coexpressing activated Ras pathway components with GAL4 fusion transactivators and a GAL4-dependent reporter gene.**

- a. The amount of expression plasmid transfected into the NIH3T3 cells and the residues of the transactivation domain of each transcription factor included in the GAL4 fusion protein is indicated. The GAL4 expression constructs all use the SV40 promoter, except for Elk pFC2, which uses the CMV promoter.
- b. Basal RLU is the average number of RLUs (an arbitrary light unit) measured from NIH3T3 cells transfected with the indicated fusion activator, pFR-luc reporter, and the empty expression construct pZIP.
- c. Fold activation is the average fold increase in reporter gene expression seen for each type of fusion activator, comparing luciferase levels seen upon expression of the activated signaling component to that seen with empty expression vector pZIP. The amounts of expression plasmid used were 0.5  $\mu$ g of pZIP or pZIPrasH(61L), 0.1  $\mu$ g of pFC-MEKK, pFC-MEK1\*, or pFC-PKA. ND indicates not done.







**Altered Ets Activity In Prostate And Breast Tumor Cell Lines Can Block Anchorage -Independent Growth.**

Gabriele Foos, Christina K. Galang, and Craig A. Hauser. The Burnham Institute, 10901 N. Torrey Pines Rd., La Jolla, CA 92037, gfoos@ljcrf.edu

The Ets family of transcription factors are important downstream targets for cellular transformation. Alteration of Ets-dependent gene expression has been found to reverse the transformed phenotype of Ras transformed mouse fibroblasts and of several human tumor cell lines. We have now undertaken several approaches to better understand the role of Ets factors in mediating transformation of murine fibroblasts and in human tumor cell lines. In addition to acting as a DNA binding domain, the Ets domain has also been reported to mediate DNA-independent protein-protein interactions with a variety of other protein families, including AP-1 and NF- $\kappa$ B. To determine whether the Ets2DBD acts by binding DNA or by titrating out other factors, we have analyzed the phenotype of Ras transformed NIH3T3 cells stably expressing the Ets2DBD with various DNA binding mutants. In addition we tested the effect on Ets2DBD reversion activity of fusing it to a heterologous activation or repression domain. Only fusion to the Engrailed repressor domain increased the apparent reversion activity. Together, these results indicate that the Ets2DBD is binding to DNA and acting to inhibit the Ets-dependent expression of target genes required to maintain cellular transformation.

To study Ets signaling in human tumor cells, we have established and analyzed clones from prostate (PPC-1) and breast (MDA-MB-435) tumor cell lines stably expressing either the Ets2DBD or full-length Ets2. Analysis of multiple independent clones from either type of tumor line revealed that expression of the Ets2DBD or full-length Ets2 altered cell morphology and inhibited anchorage-independent growth. Expression of the Ets2 constructs had distinct effects on Ets-dependent gene expression in the prostate and breast cancer cell lines. The Ets2 and Ets2DBD expressing PPC-1 cell lines exhibited slower attached growth, a dramatic 8-fold increase in apoptotic cell death and increased p21<sup>Cip</sup> expression. Expression of the Ets2DBD caused a 5-fold inhibition of PPC-1 cell migration and a complete inhibition of *in vitro* invasiveness. Interestingly, PPC-1 clones expressing full-length Ets2 did not show decreased invasiveness. This difference suggested that they have some distinct target. Ets target genes that might be involved in the transformed phenotype will be presented. Overall, these results indicate that the balance of Ets factor activity is important for maintaining multiple aspects of the transformed phenotype of human tumor cells, and that modulation of Ets activity represents a potential therapeutic target.

**Altered Ets Activity In Prostate And Breast Tumor Cell Lines Can Block Anchorage -Independent Growth.**

Gabriele Foos, Christina K. Galang, and Craig A. Hauser. The Burnham Institute, 10901 N. Torrey Pines Rd., La Jolla, CA 92037, gfoos@ljcrf.edu

The Ets family of transcription factors are important downstream targets for cellular transformation in several experimental systems. We have now established clones from prostate (PPC-1) and breast (MDA-MB-435) tumor cell lines which stably express either the Ets2 DNA binding domain (Ets2DBD) or full-length Ets2. Analysis of multiple independent clones from either type of tumor revealed that expression of the dominant negative Ets2DBD altered cell morphology and inhibited anchorage-independent growth. Expression of the activating construct Ets2 has distinct effects on transcription and transformation in the prostate and the breast cancer cell lines.

The Ets2 and Ets2DBD expressing PPC-1 cell lines showed slower growth and a dramatic increase in apoptotic cell death (8-fold). Expression of the Ets2DBD caused a 5-fold inhibition of PPC-1 cell migration and a complete inhibition of *in vitro* invasiveness. Interestingly, expression of full-length Ets2 did not inhibit invasiveness through Matrigel. The difference in invasion activity of the inhibitory or activating Ets constructs suggest that they have some distinct targets. Overall, these results indicate that the balance of Ets factor activity is important for maintaining multiple aspects of the transformed phenotype of PPC-1 prostate tumor cells and MDA-MB-435 breast cancer cell lines.

**ROLE OF ETS2 IN CELLULAR TRANSFORMATION IN A MODEL CELL LINE  
AND HUMAN BREAST CANCER CELL LINE**

Gabriele E. Foos and Craig A. Hauser

The Burnham Institute, 10901 N. Torrey Pines Road, La Jolla, CA 92037

E-mail: gfoos@ljcrf.edu

Members of the Ets transcription factor family are downstream targets of the Ras signal transduction pathway and mediate changes in gene expression associated with many oncogenes. There is accumulating evidence that Ras signaling through Ets proteins is important for cellular transformation. We and others have found that stable expression of a dominant inhibitory Ets2 mutant, the Ets2 DNA binding domain (Ets2DBD) can reverse the transformed phenotype of Ras transformed NIH3T3 cells (DT-3T3). Surprisingly we found that stable overexpression of the transcriptional activator full-length Ets2 can also reverse the transformed properties of these cells, including anchorage independent growth in soft agar, cell morphology, reorganization of actin stress fibers and tumorigenicity in nude mice. The reversion activity of full-length Ets2 correlates with its activation activity in these cells. The DT cell lines reverted by the Ets2 constructs did not show reduced attached cell growth or changes in Ras expression or MAP kinase activity. To determine whether inhibition or activation of Ets-dependent transcription can have similar effects on human breast tumor cell lines we have now established clones from breast tumor cell line (MDA-MB-435) which stably express either the Ets2 DNA binding domain (Ets2DBD) or full-length Ets2. Analysis of multiple independent clones revealed that expression of either the dominant negative Ets2DBD or the activator full-length Ets2 altered cell morphology and strongly inhibited anchorage-independent growth. In contrast to the DT-3T3 cells, the breast cell lines expressing Ets2 constructs showed reduced attached cell growth relative to the parental line. To avoid problems with toxicity and to study the direct gene targets of Ets2, stable breast cell lines with inducible Ets2 constructs are now being generated and analyzed. Overall we have found that activation of Ets-dependent transcription can reverse the transformed phenotype of rodent fibroblasts or human breast cancer cell lines. These results suggest that the balance of Ets factor activity is important for maintaining multiple aspects of the transformed phenotype of breast tumor cells, and are an appropriate target for intervention.

The U.S. Army Medical Research and Material Command under DAMD17-97-1-7150 supported this work.

**Altered Ets Activity In Prostate Or Breast Tumor Cell Lines Can Block Anchorage-Independent Growth And Invasiveness.**

Gabriele Foos, Christina K. Galang, and Craig A. Hauser. The Burnham Institute, 10901 N. Torrey Pines Rd., La Jolla, CA 92037, gfoos@ljcrf.edu

The Ets family of transcription factors are important downstream targets for cellular transformation. Altering Ets-dependent gene expression can reverse the transformed phenotype of several cell lines. We have utilized dominant inhibitory or activating Ets2 constructs to characterize the role and targets of Ets factors in mediating transformation of murine fibroblasts and in human tumor cell lines. To distinguish whether expression of the Ets2 DNA binding domain (Ets2DBD) reverts Ras-transformed NIH3T3 cells by binding DNA, or through reported protein-protein interactions with AP-1 and NF- $\kappa$ B family members, we have analyzed the reversion activity of stably expressed Ets2DBD point mutants which have lost DNA binding activity. All of these Ets2DBD mutants lost their ability to reverse transformation. In addition, fusing the Ets2DBD to a heterologous transcription activation or repression domain demonstrated that active repression by the dominant inhibitory Ets2DBD construct increased its apparent reversion activity. Together, these results indicate that the Ets2DBD is binding to DNA and acting to inhibit the Ets-dependent expression of target genes required to maintain Ras transformation.

To study Ets signaling in human tumor cells, we have established and analyzed clones from prostate (PPC-1) and breast (MDA-MB-435) tumor cell lines stably expressing either the Ets2DBD or full-length Ets2. Analysis of multiple independent clones from either type of tumor line revealed that expression of the Ets2DBD or full-length Ets2 altered cell morphology and inhibited anchorage-independent growth. Expression of the Ets2 constructs had distinct effects on Ets-dependent gene expression in the prostate and breast cancer cell lines. PPC-1 cell lines expressing Ets2 or the Ets2DBD exhibited slower attached growth, increased p21<sup>Cip</sup> expression, and a dramatic 8-fold increase in apoptotic cell death. Expression of the Ets2DBD inhibited PPC-1 cell migration and completely blocked *in vitro* invasiveness. Interestingly, PPC-1 clones expressing full-length Ets2 did not show decreased invasiveness, revealing that the different Ets2 constructs have some distinct targets. Analysis of altered Ets target gene expression in the various reverted tumor cell lines will be presented. Overall, these results indicate that the balance of Ets factor activity is important for maintaining multiple aspects of the transformed phenotype of human tumor cells, and that modulation of Ets activity represents a potential therapeutic target.