

AFRL-PR-WP-TR-2001-2010

**HIGH CYCLE FATIGUE (HCF) SCIENCE AND
TECHNOLOGY PROGRAM
2000 ANNUAL REPORT**



Brian Garrison, et al.

Prepared by:

**Universal Technology Corporation
1270 North Fairfield Road
Dayton OH 45432-2600**

JANUARY 2000

FINAL REPORT FOR 01 JANUARY 2000 –31 DECEMBER 2000

APPROVED FOR PUBLIC RELEASE; DISTRIBUTION UNLIMITED

**PROPULSION DIRECTORATE
AIR FORCE RESEARCH LABORATORY
AIR FORCE MATERIEL COMMAND
WRIGHT-PATTERSON AIR FORCE BASE OH 45433-7251**

Form SF298 Citation Data

Report Date <i>("DD MON YYYY")</i> 01012001	Report Type Final	Dates Covered (from... to) <i>("DD MON YYYY")</i> 01012000 31122000
Title and Subtitle High Cycle Fatigue (HCF) Science and Technology Program 1998 Annual Report		Contract or Grant Number
Authors Garrison, Brian		Program Element Number
		Project Number
		Task Number
		Work Unit Number
Performing Organization Name(s) and Address(es) Propulsion Directorate Air Force Research Laboratory Air Force Materiel Command Wright-Patterson Air Force Base, OH 45433-7251		Performing Organization Number(s)
Sponsoring/Monitoring Agency Name(s) and Address(es) Propulsion Directorate Air Force Research Laboratory Air Force Materiel Command Wright-Patterson Air Force Base, OH 45433-7251		Monitoring Agency Acronym
		Monitoring Agency Report Number(s)
Distribution/Availability Statement Approved for public release, distribution unlimited		
Supplementary Notes		
Abstract This fourth annual report of the National Turbine Engine High Cycle Fatigue (HCF) Program is a brief review of work completed, work in progress, and technical accomplishments. This program is a coordinated effort with participation by the Air Force, the Navy, and NASA. The technical efforts are organized under eight Action Teams: Materials Damage Tolerance Research, Forced Response Prediction, Component Analysis, Instrumentation, Passive Damping Technology, Component Surface Treatments, Aeromechanical Characterization, and Engine Demonstration. Daniel E. Thomson, AFRL/PRTC, Wright-Patterson AFB, is the Program Manager.		
Subject Terms High Cycle Fatigue; Turbine Engines, Instrumentation; Damping; Forced Response; Aeromechanical Characterization; Materials; Surface Treatments; Laser Shock Peening; Component Analysis; Damage Tolerance		
Document Classification unclassified		Classification of SF298 unclassified

Classification of Abstract unclassified	Limitation of Abstract unlimited
Number of Pages 219	

NOTICE

USING GOVERNMENT DRAWINGS, SPECIFICATIONS, OR OTHER DATA INCLUDED IN THIS DOCUMENT FOR ANY PURPOSE OTHER THAN GOVERNMENT PROCUREMENT DOES NOT IN ANY WAY OBLIGATE THE US GOVERNMENT. THE FACT THAT THE GOVERNMENT FORMULATED OR SUPPLIED THE DRAWINGS, SPECIFICATIONS, OR OTHER DATA DOES NOT LICENSE THE HOLDER OR ANY OTHER PERSON OR CORPORATION; OR CONVEY ANY RIGHTS OR PERMISSION TO MANUFACTURE, USE, OR SELL ANY PATENTED INVENTION THAT MAY RELATE TO THEM.

THIS REPORT IS RELEASABLE TO THE NATIONAL TECHNICAL INFORMATION SERVICE (NTIS). AT NTIS, IT WILL BE AVAILABLE TO THE GENERAL PUBLIC, INCLUDING FOREIGN NATIONS.

THIS TECHNICAL REPORT HAS BEEN REVIEWED AND IS APPROVED FOR PUBLICATION.



Daniel E. Thomson, AFRL/PRTC



Theodore G. Fecke, AFRL/PRTC



Richard J. Hill, AFRL/PRT

IF YOUR ADDRESS HAS CHANGED, IF YOU WISH TO BE REMOVED FROM OUR MAILING LIST, OR IF THE ADDRESSEE IS NO LONGER EMPLOYED BY YOUR ORGANIZATION PLEASE NOTIFY AFRL/PRT, WRIGHT-PATTERSON AFB OH 45433-7251 TO HELP MAINTAIN A CURRENT MAILING LIST.

Do not return copies of this report unless contractual obligations or notice on a specific document requires its return.

REPORT DOCUMENTATION PAGEForm Approved
OMB No. 074-0188

Public reporting burden for this collection of information is estimated to average 1 hour per response, including the time for reviewing instructions, searching existing data sources, gathering and maintaining the data needed, and completing and reviewing this collection of information. Send comments regarding this burden estimate or any other aspect of this collection of information, including suggestions for reducing this burden to Washington Headquarters Services, Directorate for Information Operations and Reports, 1215 Jefferson Davis Highway, Suite 1204, Arlington, VA 22202-4302, and to the Office of Management and Budget, Paperwork Reduction Project (0704-0188), Washington, DC 20503

1. AGENCY USE ONLY (Leave blank)		2. REPORT DATE January 2001	3. REPORT TYPE AND DATES COVERED Final 01/01/2000– 12/31/2000	
4. TITLE AND SUBTITLE High Cycle Fatigue (HCF) Science and Technology Program 1998 Annual Report			5. FUNDING NUMBERS C – F33615-98-C-2807 PE – 62203F PR – APPL	
6. AUTHOR(S) Brian Garrison, et al.			TA – TO WU - 04	
7. PERFORMING ORGANIZATION NAME(S) AND ADDRESS(ES) Propulsion Directorate Air Force Research Laboratory Air Force Materiel Command Wright-Patterson Air Force Base, OH 45433-7251			Universal Technology Corporation 1270 N. Fairfield Rd. Dayton, OH 45432-2600	
9. SPONSORING / MONITORING AGENCY NAME(S) AND ADDRESS(ES) Propulsion Directorate Air Force Research Laboratory Air Force Materiel Command Wright-Patterson Air Force Base, OH 45433-7251 POC: Daniel E. Thomson, AFRL/PRTC, (937) 255-2081			8. PERFORMING ORGANIZATION REPORT NUMBER 10. SPONSORING / MONITORING AGENCY REPORT NUMBER AFRL-PR-WP-TR-2001-2010	
11. SUPPLEMENTARY NOTES				
12a. DISTRIBUTION / AVAILABILITY STATEMENT Approved for Public Release; Distribution Unlimited				12b. DISTRIBUTION CODE
13. ABSTRACT (Maximum 200 Words) This fourth annual report of the National Turbine Engine High Cycle Fatigue (HCF) Program is a brief review of work completed, work in progress, and technical accomplishments. This program is a coordinated effort with participation by the Air Force, the Navy, and NASA. The technical efforts are organized under eight Action Teams: Materials Damage Tolerance Research, Forced Response Prediction, Component Analysis, Instrumentation, Passive Damping Technology, Component Surface Treatments, Aeromechanical Characterization, and Engine Demonstration. Daniel E. Thomson, AFRL/PRTC, Wright-Patterson AFB, is the Program Manager.				
14. SUBJECT TERMS High Cycle Fatigue, Turbine Engines, Instrumentation, Damping, Forced Response, Aeromechanical Characterization, Materials, Surface Treatments, Laser Shock Peening, Component Analysis, Damage Tolerance				15. NUMBER OF PAGES 219
				16. PRICE CODE
17. SECURITY CLASSIFICATION OF REPORT Unclassified	18. SECURITY CLASSIFICATION OF THIS PAGE Unclassified	19. SECURITY CLASSIFICATION OF ABSTRACT Unclassified	20. LIMITATION OF ABSTRACT SAR	

NSN 7540-01-280-5500

Standard Form 298 (Rev. 2-89)
Prescribed by ANSI Std. Z39-18
298-102

TABLE OF CONTENTS

Page

FOREWORD	xiv
1.0 COMPONENT SURFACE TREATMENTS	1
1.1 <i>Laser Shock Peening (LSP) vs. Shot Peening Competition</i>	3
1.2 <i>Laser Optimization Development</i>	5
1.3 <i>Production LSP Facility Development</i>	6
1.4 <i>LSP Process Modeling</i>	7
1.5 <i>RapidCoater[®] for LSP</i>	9
1.5.1 <i>Rapid Overlay Concept Development</i>	10
1.5.2 <i>Development of a RapidCoater[®] Manufacturing System</i>	10
1.6 <i>Manufacturing Technology for Affordable LSP</i>	12
1.7 <i>Laser Peening of F119 Fourth-Stage Integrally Bladed Rotors</i>	15
1.8 <i>Small Engine LSP</i>	17
1.9 <i>Conclusion</i>	17
2.0 MATERIALS DAMAGE TOLERANCE	19
2.1 <i>Microstructure Effects of Titanium HCF (Fan)</i>	21
2.2 <i>Air Force In-House Research (Fan & Turbine)</i>	23
2.3 <i>HCF and Time-Dependent Failure in Metallic Alloys for Propulsion Systems (Fan & Turbine)</i>	32
2.4 <i>Improved HCF Life Prediction (Fan)</i>	42
2.5 <i>Advanced HCF Life Assurance Methodologies (Fan & Turbine)</i>	48
2.6 <i>Future Efforts</i>	54
2.7 <i>Conclusion</i>	55
3.0 INSTRUMENTATION	56
3.1 <i>Improved Non-Contact Stress Measurement System (NSMS)</i>	58
3.1.1 <i>Improved NSMS Hardware (Generation 4)</i>	58
3.1.2 <i>Alternate Tip Sensors</i>	60
3.1.3 <i>Enhanced Data Processing Capability for Generation 4 & 5 NSMS Development</i>	62
3.1.4 <i>Spin Pit Validation of NSMS</i>	65
3.1.5 <i>High-Temperature NSMS Sensor Development</i>	69

TABLE OF CONTENTS (Cont'd)

	<u>Page</u>
3.1.6	<i>Dual Use Science and Technology (DUST)</i> 69
3.2	<i>Environmental Mapping System</i> 70
3.2.1	<i>Pressure/Temperature Sensitive Paint (PSP/TSP)</i> 70
3.2.1.1	<i>PSP: Improved Dynamic Response</i> 71
3.2.1.2	<i>PSP: Light Emitting Diodes (PSP-LEDs)</i> 75
3.2.2	<i>Comparison Testing / Air Etalons</i> 76
3.2.3	<i>Validation of Paint / Optical Pressure Mapping</i> 78
3.2.4	<i>Wireless Telemetry</i> 78
3.2.5	<i>MEMS Pressure Sensor</i> 79
3.2.6	<i>AlN Sensors</i> 80
3.3	<i>Improved Conventional Sensors</i> 82
3.3.1	<i>Non-Optical NSMS Sensor Development (Eddy Current)</i> 82
3.4	<i>Development of Long-Life, Less Intrusive Gages</i> 85
3.4.1	<i>Advanced Thin-Film Dynamic Gages</i> 85
3.4.2	<i>Advanced High-Temperature Thin-Film Dynamic Gages</i> 86
3.5	<i>Conclusion</i> 87
4.0	COMPONENT ANALYSIS 88
4.1	<i>Assessment of Turbine Engine Components</i> 90
4.2	<i>Probabilistic Design of Turbine Engine Airfoils, Phase I</i> 92
4.3	<i>Probabilistic Design of Turbine Engine Airfoils, Phase II</i> 94
4.4	<i>Probabilistic Blade Design System</i> 95
4.5	<i>Efficient Probabilistic Analysis Methods for Turbine Engine Components</i> 96
4.6	<i>PREDICT</i> 98
4.7	<i>Conclusion</i> 98
5.0	FORCED RESPONSE PREDICTION 99
5.1	<i>Development of Physical Understanding and Models</i> 103
5.1.1	<i>Development of TURBO-AE</i> 103
5.1.2	<i>Nonlinear Modeling of Stall/Flutter</i> 104

5.1.3	<i>Forced Response: Mistuned Bladed Disks (REDUCE Code)</i>	105
-------	---	-----

TABLE OF CONTENTS (Cont'd)

		<u>Page</u>
5.1.4	<i>Design Guidelines for Mistuned Bladed Disks (REDUCE Code)</i>	106
5.1.5	<i>Tip Modes in Low-Aspect-Ratio Blading</i>	107
5.1.6	<i>Development of Aeroelastic Capability for the TURBO Code</i>	108
5.1.7	<i>Dynamic Analysis & Design of Shroud Contact</i>	109
5.1.8	<i>Friction Damping in Bladed Disks</i>	110
5.2	<i>Acquisition of Experimental Data</i>	111
5.2.1	<i>High Mach Forcing Functions</i>	111
5.2.2	<i>Forward-Swept Blade Aeromechanics</i>	112
5.2.3	<i>Oscillating Cascade Rig</i>	113
5.2.4	<i>F109 Unsteady Stator Loading</i>	115
5.2.5	<i>Fluid-Structure Interaction (Fans)</i>	117
5.2.6	<i>Experimental Study of Forced Response in Turbine</i>	119
5.3	<i>Validation of Analytical Models</i>	121
5.3.1	<i>Evaluation of Current State-of-the-Art Unsteady Aerodynamic Models for the Prediction of Flutter & Forced Vibration Response</i>	121
5.3.2	<i>Evaluation of State-of-the-Art Unsteady Aerodynamic Models</i>	122
5.3.3	<i>Forced Response Prediction System (Fans)</i>	123
5.3.4	<i>Aeromechanical Design System Validation</i>	124
5.4	<i>New Efforts</i>	125
5.5	<i>Conclusion</i>	125
6.0	<i>PASSIVE DAMPING TECHNOLOGY</i>	126
6.1	<i>Identification & Characterization of Damping Techniques</i>	128
6.1.1	<i>Mechanical Damping Concepts</i>	128
6.1.2	<i>Air Force In-House Damping Investigations</i>	130
6.1.3	<i>Centrifugally Loaded Viscoelastic Material Characterization Testing</i>	135
6.1.4	<i>Damping for Extreme Environments</i>	138
6.1.5	<i>Centrifugally Loaded Particle Damping</i>	141

6.1.6	<i>Coatings for Damping Turbine Engine Components</i>	143
6.1.7	<i>Development of Air Film Damping for Turbine Engine Applications</i>	145

TABLE OF CONTENTS (Cont'd)

	<u>Page</u>
6.2	<i>Modeling and Incorporation of Damping in Components</i> 151
6.2.1	<i>Advanced Damping Concepts for Reduced HCF</i> 151
6.2.2	<i>Evaluation of Reinforced Swept Airfoils / Internal Dampers</i> 153
6.2.3	<i>Damping Systems for the Integrated High Performance Turbine Engine Technology (IHPTET) Program</i> 154
6.2.4	<i>Damping for Turbines</i> 161
6.2.5	<i>Dual Use Program</i> 162
6.2.6	<i>Transition of Damping Technology to counterrotating Low Pressure Turbine Blades</i> 163
6.3	<i>Affordable Damped Components</i> 164
6.4	<i>Conclusion</i> 165
7.0	<i>ENGINE DEMONSTRATION</i> 166
7.1	<i>General Electric / Allison Advanced Development Company</i> 169
7.1.1	<i>XTC76/2</i> 169
7.1.2	<i>XTC76/3</i> 170
7.1.3	<i>XTE77/SE</i> 171
7.1.4	<i>XTE76/1</i> 172
7.1.5	<i>XTC77</i> 173
7.2	<i>Pratt & Whitney</i> 175
7.2.1	<i>XTE66/A1</i> 175
7.2.2	<i>XTC66/SC</i> 176
7.2.3	<i>XTC66/1B</i> 177
7.2.4	<i>XTE66/1</i> 178
7.2.5	<i>XTC67/1</i> 179
7.2.6	<i>XTE66/SE</i> 180
7.2.7	<i>XTE67/1</i> 181

7.2.8	<i>XTE65/3</i>	182
7.2.9	<i>XTE67/SE1</i>	183
7.2.10	<i>XTE67/SE2</i>	184

TABLE OF CONTENTS (Cont'd)

	<u>Page</u>
7.3	<i>Conclusion</i> 184
8.0	<i>AEROMECHANICAL CHARACTERIZATION</i> 185
8.1	<i>Compressor Mistuning Characterization</i> 187
8.2	<i>Fretting Characterization</i> 188
8.3	<i>Spin-Pit Excitation Methods</i> 189
8.4	<i>Compressor Blade Fracture & Fatigue Evaluation</i> 190
8.5	<i>Rotational Validation of Mistuning Model</i> 191
8.6	<i>Development of Multi-Axial Fatigue Testing Capability</i> 192
8.7	<i>Inlet Distortion Characterization</i> 194
8.8	<i>Engine Structural Integrity Program (ENSIP) / Joint Service Specification Guide (JSSG)</i> 196
8.9	<i>Conclusion</i> 197
	<i>List of Acronyms</i> 198

LIST OF FIGURES

		<u>Page</u>
FIGURE 1	<i>HCF Team Organizational Structure</i>	xv
FIGURE 2	<i>Damage Tolerance Data for LSP'd Blades.....</i>	3
FIGURE 3	<i>What Is Laser Shock Peening?</i>	4
FIGURE 4	<i>Peak Rise Time Before & After Laser System Modifications.....</i>	5
FIGURE 5	<i>Schematic of Laser System Operations.....</i>	6
FIGURE 6	<i>Comparison of Modeled and Experimental Residual Stresses for Estimated Similar Pressure Conditions</i>	8
FIGURE 7	<i>A Single RapidCoater[™] Head (a) for Single-Sided Processing and a Dual RapidCoater[™] Head, and (b) for Processing a Thin Section, Such as Compressor Blade.....</i>	11
FIGURE 8	<i>Spatial Profiles of the Laser Beam Showing the Transformation from a Round Spot (a) to a Square Spot (b) with the Use of Optics (c).....</i>	11
FIGURE 9	<i>One of 48 PFNs That Are Being Integrated into the Laser System</i>	13
FIGURE 10	<i>The PFN bays are located under the optical table. Electrical wiring to power the PFNs is in progress (a) and the drawers to support them have been constructed (b).....</i>	14
FIGURE 11	<i>Two LSP'd IBRs: (a) A Fourth-Stage Compressor IBR and (b) a First-Stage Fan IBR for the F119 Engine.....</i>	16
FIGURE 12	<i>Interrelationship between LSP Programs.....</i>	18
FIGURE 13	<i>S-N Input Data and Fatigue Strength Model Results for Bimodal Fine Uni-Rolled, Bimodal Forged, and Equiaxed Forged Microstructures (Top to Bottom) at R=0.1</i>	22
FIGURE 14	<i>Pre-Crack and Step-Test Loading Technique Used to Determine LCF/HCF Thresholds.....</i>	24
FIGURE 15	<i>Model Correlation for Ti-6Al-4V and Ti-17 for Different Values of Stress Ratio, R.....</i>	24
FIGURE 16	<i>Stress-relieved Threshold Crack Growth Values for Ti-6Al-4V and Ti-17 Fatigued at R=0.1.....</i>	25
FIGURE 17	<i>Fretting Pad (Top) and Non-Traditional “Golden Arch” Specimens (Bottom).....</i>	27
FIGURE 18	<i>Fatigue Crack Threshold Values for Pads Exposed to Different Fretting Fatigue Conditions</i>	27
FIGURE 19	<i>Cyclic Evolution of Friction Force for Copper-Based Coating System</i>	28

LIST OF FIGURES (Cont'd)

		<u>Page</u>
FIGURE 20	<i>The Effect of Notch Depth Ratio on Normalized Fatigue Limit Stress</i>	29
FIGURE 21	<i>The Effect of Irregular (Chipped) Notches on Fatigue Limit Stress</i>	30
FIGURE 22	<i>Different Levels of Damage In Dovetail Fatigue Specimens</i>	31
FIGURE 23	<i>Effect of Frequency on Fatigue Crack Growth for Bimodal Ti-6Al-4V in Room Air</i>	33
FIGURE 24	<i>Constant-K_{max} Fatigue Crack Propagation Behavior at K_{max} Values of 26.5, 36.5, 46.5, and 56.5 MPa\sqrt{m}</i>	34
FIGURE 25	<i>Combinations of (a) K_{max}-R, (b) DK-R, and (c) DK-K_{max} Required for “Threshold” Growth at 10^{-10} m/cycle</i>	34
FIGURE 26	<i>Comparison of Worst-Case Large-Crack Propagation Data to Fatigue Growth from Naturally-Initiated Small Cracks and Small Cracks Originating from FOD Sites</i>	35
FIGURE 27	<i>Mixed-Mode Fatigue-Crack Growth Thresholds in Bimodal Ti-6Al-4V Plotted in Terms of (a) Strain Energy Release Rate, DG_{th}, and (b) Mode I Stress Intensity Range at Threshold, $DK_{i,th}$</i>	35
FIGURE 28	<i>Fatigue-Crack Propagation Curves for Fine-Grained KM4 at 25°, 550° and 650°C</i>	36
FIGURE 29	<i>Crack-Growth Rates as a Function of Applied Stress-Intensity Range of FOD- and Naturally-Initiated Small Cracks and Through-Thickness Large Cracks</i>	37
FIGURE 30	<i>Modified Kitigawa-Takahashi Diagram Representing the Threshold Crack-Growth Conditions for FOD-Induced Small Cracks in Ti-6Al-4V</i>	37
FIGURE 31	<i>Survey of Residual Strain Gradient Emanating Away from the Crater Rim at the Surface of the Specimen</i>	38
FIGURE 32	<i>Results from a 2-Dimensional Strain Survey Around a 200 m/s Impact Site Isostrain Contour Values on Right in Units of $\mu\epsilon$</i>	39
FIGURE 33	<i>Fretting Fatigue Results from Experiments on Mill Annealed Ti-6Al-4V Illustrating Variation of Total Life with Changes in the Bulk Stress Applied to the Specimen</i>	40
FIGURE 34	<i>Fretting Fatigue Results from Experiments on Mill Annealed and STOA Ti-6Al-4V Illustrating Variation of Total Life with Changes in the Tangential Loads Applied to Fretting Contact. ($S_b = 300$ MPa, $m = 0.95$)</i>	40
FIGURE 35	<i>Fretting Fatigue Results from Experiments on Mill Annealed and STOA Ti-6Al-4V Illustrating Variation of Total Life with Changes in the Normal Loads Applied to Fretting Contact ($S_b = 300$ MPa, $m = 0.95$)</i>	41

FIGURE 36 *Fatigue Crack Propagation Rate of Naturally-Initiated “Small” Cracks
as a Function of: (a) Crack Size and (b) Stress Intensity Factor Range43*

LIST OF FIGURES (Cont'd)

	<u>Page</u>
FIGURE 37	<i>Representative FOD from Ballistic and Solenoid Gun Impacts (Sharp Leading Edge Specimens, 30° Impacts, High Damage Levels).....</i> 44
FIGURE 38	<i>Normalized Fatigue Endurance Strength as a Function of FOD Depth.....</i> 45
FIGURE 39	<i>Evolution of Coefficient of Friction</i> 46
FIGURE 40	<i>Comparison of Surface Normal Traction Obtained from Integral Equation and FEM Methods.....</i> 46
FIGURE 41	<i>Influence of 1.4% LCF Damage on HCF Properties of Ti-6Al-4V</i> 49
FIGURE 42	<i>Half-Life Properties of Ti-17b.....</i> 49
FIGURE 43	<i>Correlation of Fretting G Parameter to Uniaxial Fatigue Curve.....</i> 51
FIGURE 44	<i>High-Temperature Fretting Fatigue Rig.....</i> 51
FIGURE 45	<i>Improvement of Equivalent Flaw Size Parameter over Current Design Procedures</i> 52
FIGURE 46	<i>Comparison of Fracture Mechanics Based Threshold Stress and Life Predictions from Existing Design Methods</i> 53
FIGURE 47	<i>Next-Generation NSMS Overview.....</i> 58
FIGURE 48	<i>Data Processing for Generation 4 & 5 NSMS Development.....</i> 62
FIGURE 49	<i>NSMS Development Schedule.....</i> 64
FIGURE 50	<i>Light-Probe NSMS Validation Measurements on a 36-Inch Diameter Two-Stage Compressor.....</i> 66
FIGURE 51	<i>Light Probe System and Signal-PC Interface Board</i> 67
FIGURE 52	<i>Heath's Method Applied to Determine Blade Resonance: NSMS Probe Data Through Resonance.....</i> 67
FIGURE 53	<i>Heath's Method Applied to Determine Blade Resonance: Least Squares Fit to an Ellipse.....</i> 68
FIGURE 54	<i>Experimental Setup for PSP Response to a Shock</i> 71
FIGURE 55	<i>Response of Sol-Gel on DuPont to the Initial Shock Wave in the Shock Tube.....</i> 72
FIGURE 56	<i>PSP Response to a 0.2-psi Pressure Modulation at 5.7 kHz.....</i> 73
FIGURE 57	<i>PSP Signal from the Wake Generator at 13,000 RPM and 11,050 RPM, and the Amplitude Response of the PSP as a Function of Frequency.....</i> 74
FIGURE 58	<i>Power Spectra of the PSP at 13,000 RPM Minus the Power Spectra of the PSP at 11,050 RPM from 5,000 to 8,000 Hz.....</i> 74
FIGURE 59	<i>Four Capacitive Sensors Monitor Blade Vibration on a 12" Rotor at the Naval Post-Graduate School Spin Pit Facility in Monterey, California</i> 83

LIST OF FIGURES (Cont'd)

	<u>Page</u>
FIGURE 60	<i>Hardware & Software to Monitor Rotor and Blade Dynamics Using Blade Time-of-Arrival and Tip Clearance</i> 84
FIGURE 61	<i>Analytical Prediction of Residual Stresses from LSP</i> 91
FIGURE 62	<i>Compressor Blade FOD Simulation</i> 91
FIGURE 63	<i>Probabilistic HCF Prediction Flowchart</i> 93
FIGURE 64	<i>Airfoil Stochastic Analysis</i> 97
FIGURE 65	<i>Purdue High-Speed Compressor Configuration</i> 111
FIGURE 66	<i>Surface Flow Patterns on the Airfoil Suction Side for High and Low Solidity Cascades and a Single Airfoil at Subsonic Inlet Flow Conditions</i> 114
FIGURE 67	<i>Schematic of F109 Engine Showing Location of Pressure-Instrumented Stators</i> 116
FIGURE 68	<i>Dynamic Spin Facility, NASA Glenn Research Center</i> 129
FIGURE 69	<i>Model Fan Test Article</i> 130
FIGURE 70	<i>The Electrical Connections between Piezoelectric Actuators</i> 131
FIGURE 71	<i>Extended Mode Shapes for Eight Blades</i> 132
FIGURE 72	<i>Mode Shapes for the Mistuned, Uncoupled Case</i> 133
FIGURE 73	<i>Mode Shapes for the Mistuned, Coupled Case</i> 133
FIGURE 74	<i>Mode Shapes for the Tuned, Uncoupled Case</i> 133
FIGURE 75	<i>Mode Shapes for the Tuned, Coupled Case</i> 134
FIGURE 76	<i>Viscoelastic Tub Blade Hardware</i> 135
FIGURE 77	<i>Damping Study Blade</i> 135
FIGURE 78	<i>Comparison of Measured and Predicted Static Strain</i> 136
FIGURE 79	<i>Comparison of Undamped and Damped Blade Response (One Pocket) to PZT Excitation in the Laboratory</i> 137
FIGURE 80	<i>Comparison of Experimental and Analytical Results</i> 138
FIGURE 81	<i>Hilbert Transform for Beam with Zero Particles</i> 139
FIGURE 82	<i>Eighty Particles</i> 139
FIGURE 83	<i>Subelement Strain Gage Locations on a Test Specimen</i> 140
FIGURE 84	<i>Subelement Mounted in Test Fixture</i> 140
FIGURE 85	<i>Test Blade and Hub by Itself and Installed in Centrifuge</i> 142
FIGURE 86	<i>Damping Test Specimen</i> 144

FIGURE 87 *Conceptual Drawing of an Air Film Damping System (AFDS) Applied to a Cantilever Beam*147

LIST OF FIGURES (Cont'd)

	<u>Page</u>
FIGURE 88 <i>External Air Film Damping System Applied to the GMA3007 Type III Fan Blade</i>	148
FIGURE 89 <i>Predicted Response (via Finite Element Analysis) of the GMA3007 Type III Fan Blade with the External Titanium Air Film Damping System.....</i>	149
FIGURE 90 <i>External Titanium Air Film Damping System Applied to the GMA3007 Type III fan Blade</i>	150
FIGURE 91 <i>Shear Modulus</i>	155
FIGURE 92 <i>Shear Stress.....</i>	155
FIGURE 93 <i>Shear Strain</i>	155
FIGURE 94 <i>Creep Test Results.....</i>	156
FIGURE 95 <i>Flat Plate Spin-Test Assembly</i>	156
FIGURE 96 <i>Simulated Constraining Layer</i>	157
FIGURE 97 <i>AE3007 Blade After Pocket EDM</i>	157
FIGURE 98 <i>Blade 1 with Damping System Installed.....</i>	158
FIGURE 99 <i>Blade 5 with Damping System Installed.....</i>	158
FIGURE 100 <i>Blade 5 Damping System</i>	159
FIGURE 101 <i>Blade 5 Zoomed View of Inner Region.....</i>	159
FIGURE 102 <i>The 5 KHz 1-2s Mode of a Simple Cantilevered Plate</i>	163
FIGURE 103 <i>2B/1T Mode Interaction</i>	187
FIGURE 104 <i>Mistuning Validation Simulated Bladed Disk</i>	191
FIGURE 105 <i>Proof of Concept Biaxial Fatigue Fixture.....</i>	192
FIGURE 106 <i>Multi-Axial Fatigue Model.....</i>	193
FIGURE 107 <i>Initial Correlation between Vibratory Stresses and Model Excitation Index</i>	194
FIGURE 108 <i>CFD Prediction and Measurements of 3/rev of Supersonic, Decel</i>	195
FIGURE 109 <i>Modified Correlation between Vibratory Stresses and MEI.....</i>	195

LIST OF TABLES

	<u>Page</u>
TABLE 1 <i>Kth Values Under the Selected Experimental Conditions. All Values in MPa\sqrt{m}.</i>	36
TABLE 2 <i>Materials Damage Tolerance Damage State Exit Criteria</i>	47
TABLE 3 <i>Hood Technologies Blade Tip Sensing System Applications</i>	83
TABLE 4 <i>Delphi Analysis of Damping Concepts</i>	152

FOREWORD

This document, the fourth annual report of the National Turbine Engine High Cycle Fatigue (HCF) Science and Technology (S&T) Program, is a summary of the objectives, approaches, and technical progress of ongoing and planned future efforts.

High cycle fatigue (HCF) results from vibratory stress cycles induced from various aeromechanical sources. The frequencies can be thousands of cycles per second. HCF is a widespread phenomenon in aircraft gas turbine engines that historically has led to the premature failure of major engine components (fans, compressors, turbines) and in some instances has resulted in loss of the total engine and aircraft.

Between 1982 and 1996, high cycle fatigue accounted for 56% of Class A engine-related failures. HCF is a major factor negatively impacting safety, operability, and readiness, while at the same time increasing maintenance costs. In fiscal year 1994, HCF required an expenditure of 850,000 maintenance man-hours for risk management inspections. Estimates put the cost of high cycle fatigue at over \$400 million per year.

The National HCF S&T Program officially began in December 1994. The purpose of this national effort is to help eliminate HCF as a major cause of engine failures. The Program is directed by an Air Force led steering committee consisting of representatives from the Air Force, the Navy, and NASA, along with an adjunct industry advisory panel. The Organizational Structure of the HCF Team is shown in Figure 1.

The HCF S&T Program is specifically directed at supporting the Integrated High Performance Turbine Engine Technology (IHPTET) Program, and one of its goals: to reduce engine maintenance costs. This program will try to achieve that goal through technical action team efforts targeted at a 50% reduction of HCF-related maintenance costs. In addition, the program could contribute to a reduction in HCF-related “real” development costs of over 50%. When combined with the Test and Evaluation (T&E) program, and future health monitoring approaches, the HCF S&T program should ensure the production of much more damage-tolerant high-performance engines.

The specific component objectives of the HCF S&T program are listed below:

	<u>Fans</u>	<u>Compressors</u>	<u>Turbines</u>
Determine Alternating Stress Within...	20%	25%	25%
Damp Resonant Stress By...	60%	20%	25%
Reduce Uncertainty in Capability of Damaged Components by...	50%	50%	50%
Increase Leading Edge Defect Tolerance...	15x (5-75 mils)	n/a	n/a

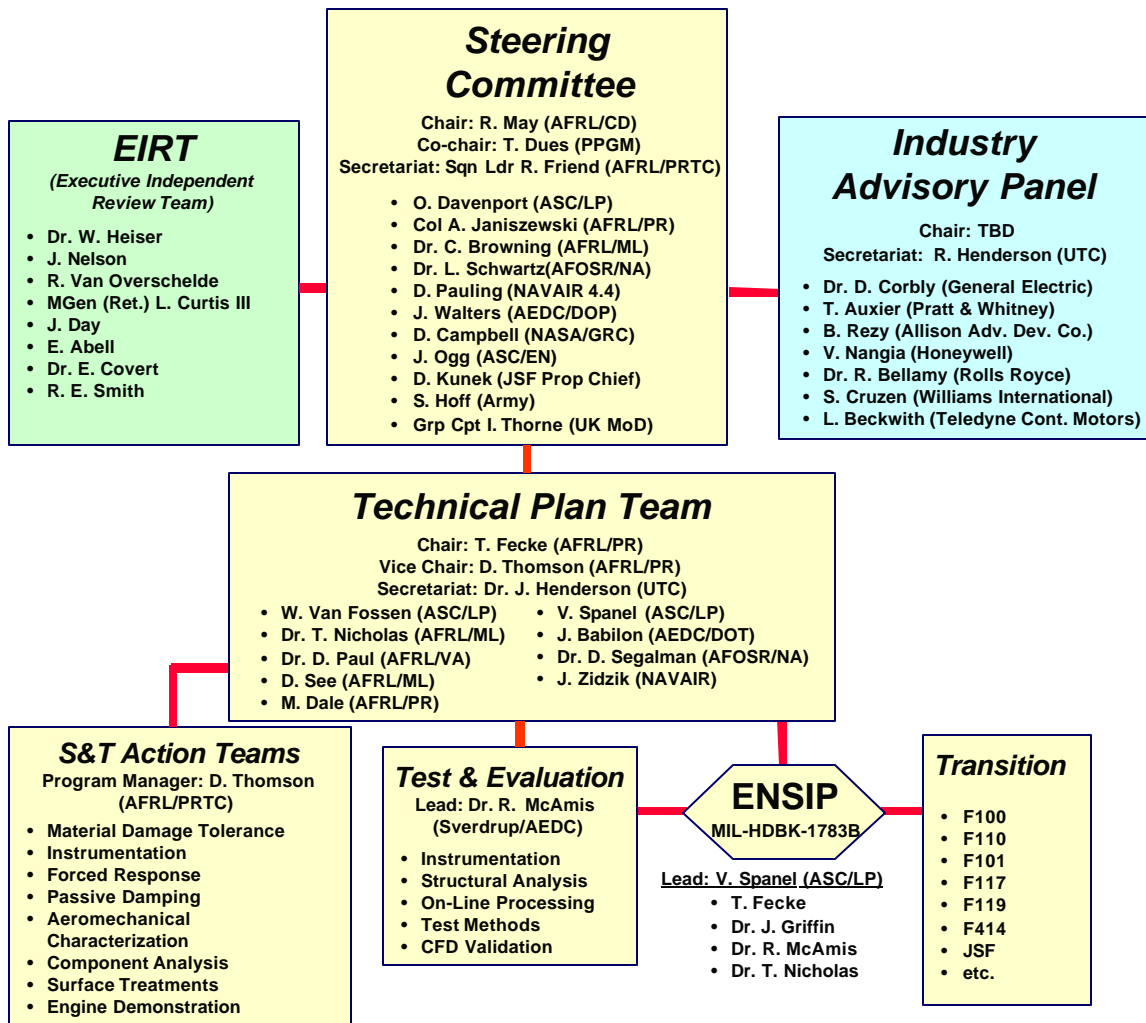

FIGURE 1. HCF Team Organizational Structure

The technical efforts are organized under eight action teams:

- Component Surface Treatments
- Materials Damage Tolerance Research
- Instrumentation
- Component Analysis
- Forced Response Prediction
- Passive Damping
- Aeromechanical Characterization
- Engine Demonstration (added in 1999)

Over the last several years, the technologies developed under the High Cycle Fatigue (HCF) Science and Technology (S&T) Program have helped solve several difficult field engine programs. As a result, we are now seeing considerably fewer major HCF events. Excellent progress has been made in the HCF program. For the first time, it appears that this once-arcanic topic is being understood and managed to a point where significant cost reductions are being realized, positively impacting the

operations, maintenance, and readiness of our combat forces. However, HCF is a very difficult technology challenge that has continued to evolve multiple technology development and transition risks. During the fall of 1999, the HCF National Action Team completed a Project “Relook” study defining the efforts necessary to mitigate these critical risk issues—both current program “shortfalls” and “new requirements.” Reprogramming plans were extensively reviewed and approved by both the HCF Industry Advisory Panel and a special committee. Implementation of these efforts is currently well underway. This reprogramming action extended the HCF program through 2006, with increased focus on Joint Strike Fighter (JSF) technology transition and greater attention to UAV/small engine issues.

Over the last year, major emphasis has also been placed on using the technology advancements developed in the HCF Technology Program to update the HCF-related portions of the Materials, Test, and Analysis sections of the Engine Structural Integrity Program (ENSIP) documentation.

During its fall 2000 meeting, the HCF Steering Committee expanded its membership to include a representative from the United Kingdom (UK). This action was taken after an extensive joint Government review of both the US and the UK HCF programs and an assessment of areas of potential technical collaboration and critical JSF technology transition issues.

In the future, the HCF S&T Program will continue as a very-high-priority national effort. Meeting the total technology challenge could essentially eliminate engine HCF-related aircraft mishaps and greatly enhance overall aircraft system readiness.

Your comments regarding the work reported in this document are welcome, and may be directed to Mr. Daniel Thomson, the HCF Program Manager, of the Air Force Research Laboratory Propulsion Directorate (AFRL/PRTC, Daniel.Thomson@wpafb.af.mil, 937-255-2081).

1.0 COMPONENT SURFACE TREATMENTS



BACKGROUND

The Component Surface Treatments Action Team (Surface Treatments AT) has the responsibility of fostering collaboration between individual HCF surface treatment efforts with the goal of increasing leading edge defect tolerance by 15x (5 mils to 75 mils). The Surface Treatments AT provides technical coordination and communication between active participants involved in Laser Shock Peening (LSP) and related technologies. Annual technical workshops have been organized and summaries of these workshops are disseminated to appropriate individuals and organizations. The Chair, Co-Chair, and selected Surface Treatments AT members meet as required (estimated quarterly) to review technical activities, develop specific goals for LSP programs, and coordinate with the Technical Plan Team (TPT) and Industry Advisory Panel (IAP). The Chairman (or Co-Chair) of the Surface Treatments AT keeps the TPT Secretary informed of AT activities on a frequent (at least monthly) basis. This AT includes members from government agencies, industry, and universities who are actively involved in surface treatment technologies applicable to engine HCF. The team is to be multidisciplinary with representatives from multiple organizations representing several component technologies as appropriate. The actual membership of the AT may change in time as individuals assume different roles in related projects.

ACTION TEAM CHAIRS



Chair

Mr. David W. See
U.S. Air Force
AFRL/MLMP, Bldg. 653
2977 P Street, Suite 6
Wright-Patterson AFB, OH 45433-7739
Phone: (937) 904-4387
Fax: (937) 656-4420
Email: david.see@afri.af.mil



Co-Chair

Mr. Rollie Dutton
U.S. Air Force
AFRL/MLLM, Bldg. 655
2230 Tenth St., Suite 1
Wright-Patterson AFB, OH 45433
Phone: (937) 255-9834
Fax: (937) 255-3007
Email: Rollie.Dutton@afri.af.mil

INTRODUCTION

The following pages summarize the schedules, backgrounds, and recent progress of the current and planned projects managed by this action team.

Component Surface Treatment Research Schedule

Product	FY95	FY96	FY97	FY98	FY99	FY00	FY01	FY02	FY03	FY04	FY05	FY06
1.1 LSP vs. Shot Peening Competition	█											
1.2 Laser Optimization Development	█											
1.3 Production LSP Facility Development		█	█	█								
1.4 LSP Process Modeling		█	█	█	█							
1.5 RapidCoater (TM) for LSP			█	█	█	█	█					
1.6 Manufacturing Technology for Affordable LSP				█	█	█	█	█				
1.7 Laser Peening of F119 Fourth-Stage Integrally Bladed Rotors						█	█					
1.8 Small Engine LSP									█	█		

1.1 Laser Shock Peening (LSP) vs. Shot Peening Competition

FY 95

Background and Final Results

In September 1995, a comparative study between a new surface treatment technology called “Laser Shock Peening” (LSP), and an established surface treatment technology called “shot peening,” was conducted. This study evaluated the damage tolerance improvements produced by these processes, specifically rating their influence for enhancing the fatigue life of turbine engine fan blades damaged by foreign objects (FOD). Critical blade characteristics, such as surface finish, change in aerodynamic profile, and manufacturability, were factored into the evaluation. The test matrix was configured to make the assessment as realistic and objective as possible. The resulting data showed that *damaged* Laser Shock Peened F101 fan blades with a 250-mil notch actually demonstrated *greater* fatigue strength than the baseline *undamaged untreated* fan blades (Fig. 2). Figure 3 describes the Laser Shock Peening process in more detail.

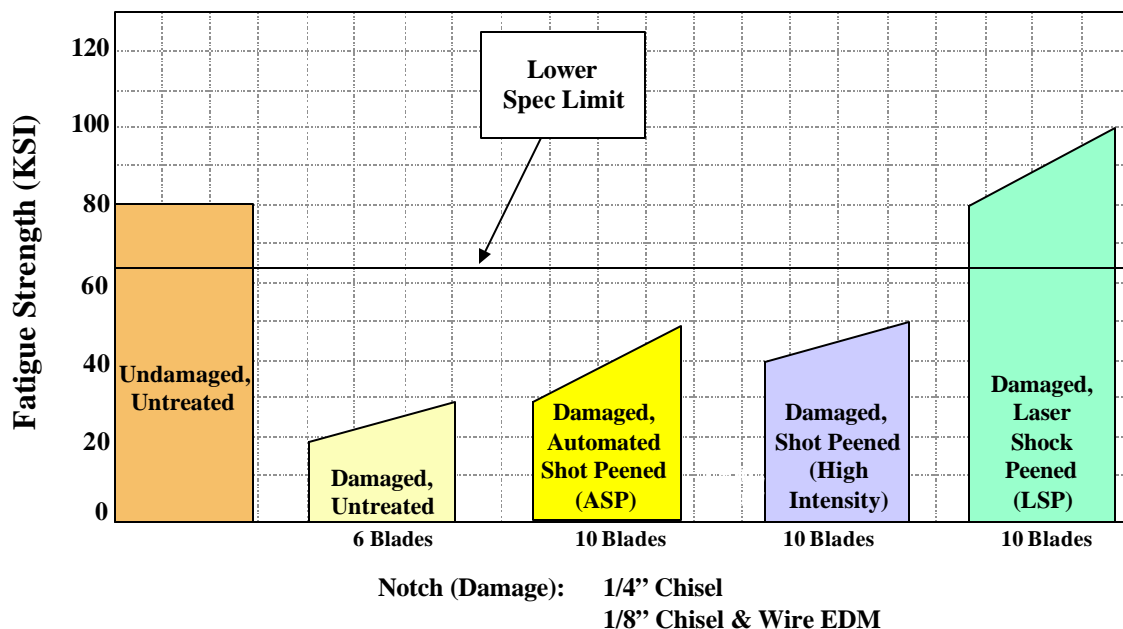

FIGURE 2. Damage Tolerance Data Indicating That Fatigue Strength of LSP'd Blades Is Equal to or Better Than That of Undamaged, Untreated Blades

Participating Organizations: GRC International, Inc.

Points of Contact:

Government

Mr. David W. See
 U.S. Air Force
 AFRL/MLMP, Bldg. 653
 2977 P Street, Suite 6
 Wright-Patterson AFB, OH 45433-7739
 Phone: (937) 255-3612
 Fax: (937) 656-4420
 Email: david.see@afri.af.mil

Contractor

Mr. Paul Sampson
 GRC International, Inc.
 2940 Presidential Dr., Suite 390
 Fairborn, OH 45424-6223
 Phone: (937) 429-7773
 Fax: (937) 429-7769
 Email: psampson@grci.com

What Is Laser Shock Peening?

- A high energy laser pulse strikes a coated surface covered by a layer of water, causing a localized high pressure energy wave.

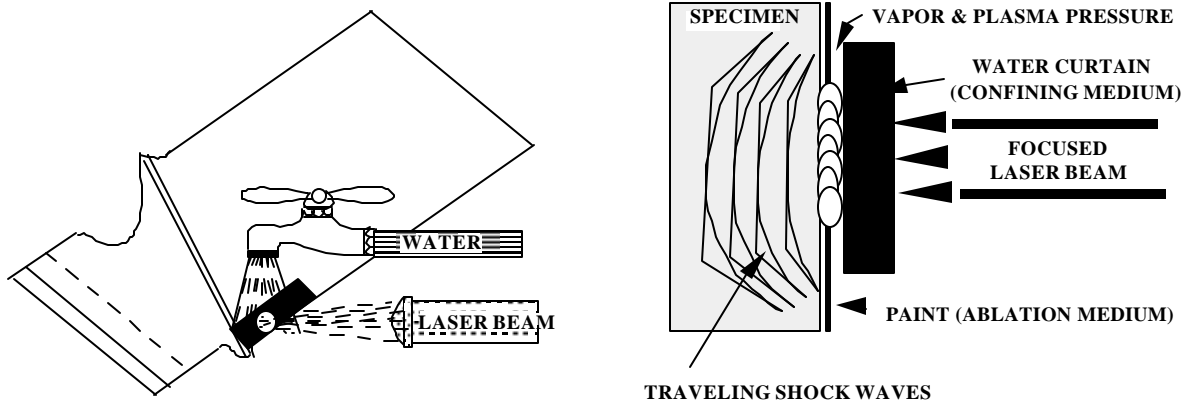

- A repetitive pattern of laser pulses results in an area of deep compressive stress.
- Results of industry and government testing have indicated the ability to stop crack initiation and propagation.

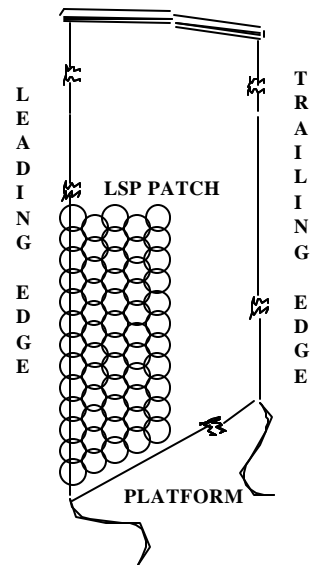

FIGURE 3. What Is Laser Shock Peening?

1.2 Laser Optimization Development FY 95

Background

The primary objective of this program was to demonstrate the effectiveness of laser peening with elliptical and circular spots in terms of its ability to increase the fatigue life of an airfoil. A secondary objective was to demonstrate the ability to sharpen the rise time of the laser pulse using an optical switch, rather than using the traditional aluminum blow-off foil.

Final Results

Airfoil-shaped test specimens were laser peened using elliptical spots and circular spots and fatigue tested by the Air Force. A study of the rise time of the temporal laser pulse was conducted to confirm that an optical switch could modify the rise time of the laser pulse as effectively as an aluminum blow-off foil. An aluminum blow-off foil has traditionally been used to sharpen the leading edge of the laser pulse. A sharp rise time is important for many LSP conditions because it increases the peak pressure of the shock wave. Both elliptical and circular spots showed significant increases in fatigue life. A rise time comparable to the rise time generated with an aluminum blow-off foil was demonstrated (Fig. 4). Using the optical switch would eliminate concerns over the presence of aluminum vapor produced by the aluminum blow-off foil and the associated risks involving the health of personal and optical-component damage. It also increases the repeatability of the process.

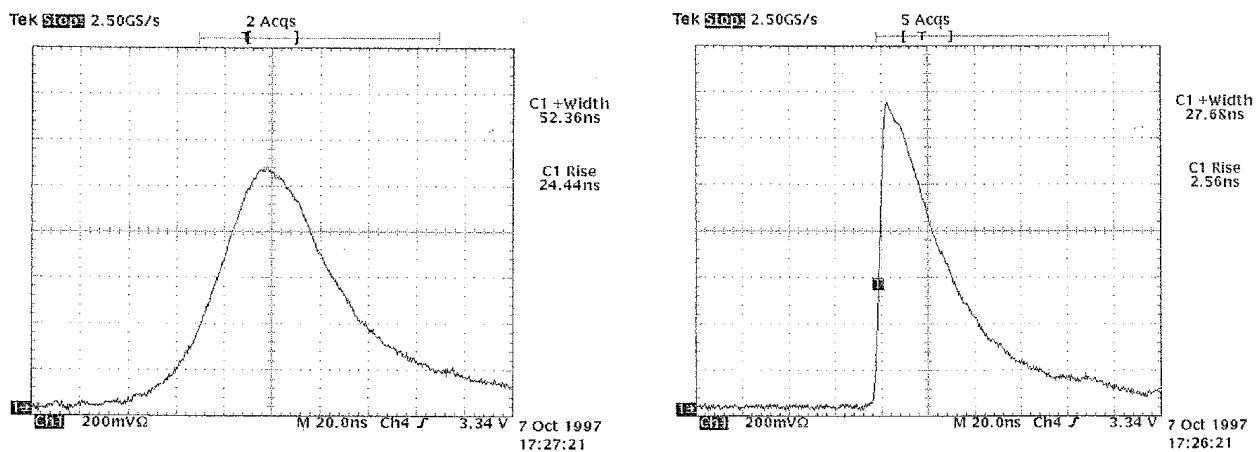

FIGURE 4. Peak Rise Time Before & After Laser System Modifications

Participating Organizations: LSP Technologies, Inc.

Points of Contact:

Government

Mr. David W. See
U.S. Air Force
AFRL/MLMP, Bldg. 653
2977 P Street, Suite 6
Wright-Patterson AFB, OH 45433-7739
Phone: (937) 255-3612
Fax: (937) 656-4420
Email: david.see@afrl.af.mil

Contractor

Dr. Jeff L. Dulaney
LSP Technologies, Inc.
6145 Scherers Place
Dublin, OH 43016-1272
Phone: (614) 718-3000 x11
Fax: (614) 718-3007
Email: jdulaney@lspt.com

1.3 Production LSP Facility Development

FY 96-98

Background

The primary objective of this program was to design and develop a Prototype Production Laser (PPL) capable of low levels of production. There were no commercially available lasers capable of meeting the requirements of the laser peening process. The program had three phases:

Phase I: Using working laboratory prototype lasers for the baseline design, the design was reviewed, outstanding technical issues related to the design were resolved, and the laser design was finalized. Specific technical issues to be resolved included:

1. The optical layout of the laser.
2. What system diagnostics would be used.
3. The mechanical design for the laser enclosure and electrical cabinets.

Phase II: Component acquisition, assembly, and subsystem checkout were accomplished during Phase II.

Phase III: Final laser system checkout and demonstration were accomplished in Phase III.

Final Results

The system, consisting of the laser, the facility, and the process (Fig. 5) was successfully demonstrated in January 1998, and the laser is now available for use by the Air Force and industry.

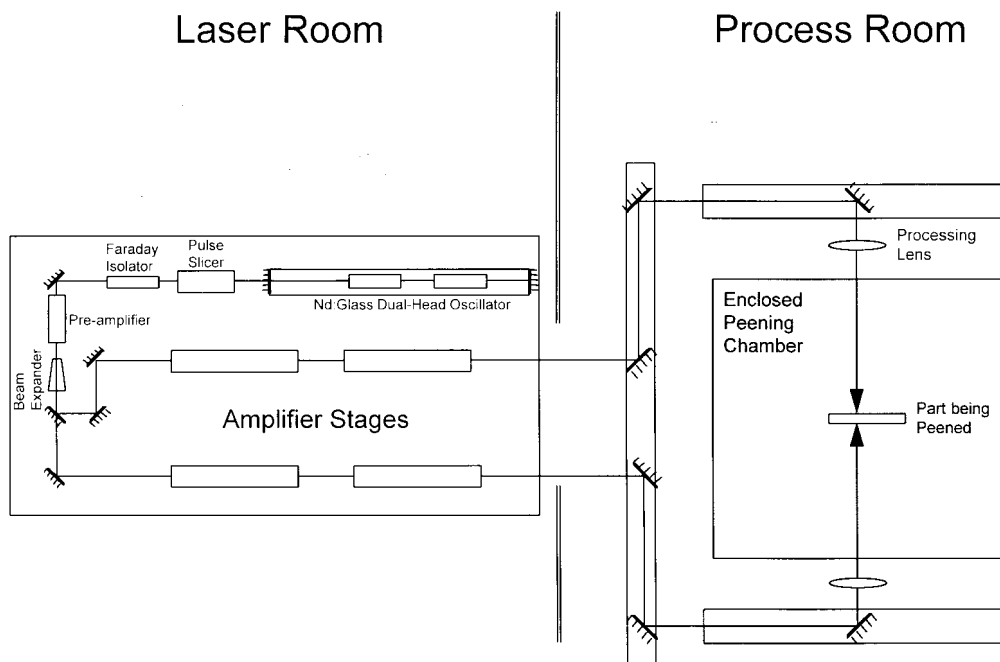

FIGURE 5. Schematic of Laser System Operations

Participating Organizations: LSP Technologies, Inc.

Points of Contact:

Government

Mr. David W. See
U.S. Air Force
AFRL/MLMP, Bldg. 653
2977 P Street, Suite 6
Wright-Patterson AFB, OH 45433-7739
Phone: (937) 255-3612
Fax: (937) 656-4420
Email: david.see@afrl.af.mil

Contractor

Dr. Jeff L. Dulaney
LSP Technologies, Inc.
6145 Scherers Place
Dublin, OH 43016-1272
Phone: (614) 718-3000 x11
Fax: (614) 718-3007
Email: jdulaney@lspt.com

1.4 LSP Process Modeling

FY 96-99

Background

In Phase I (FY 96-97) of this two-phase program, it was demonstrated that a residual stress profile could be modeled for a single laser spot. The objectives of Phase II (FY 98-99) are (1) to develop models for predicting the in-material residual stress profiles produced by multiple-spot Laser Shock Peening, (2) to verify and validate the residual stress profiles by comparison to experimental measurements, and (3) to gather appropriate data for input to the models.

A model for large-section thicknesses laser shock peened from one side has been developed and shows good correlation with experimental residual stress profiles. The correlation between the modeled and measured residual stress profiles for two different laser peening intensities (peak pressures on the metal surface) is shown in Figure 6. The thin and intermediate section thicknesses are being modeled with two-sided laser peening. This is a much more difficult problem, and several constitutive equations for the material of interest are being explored and tested with the models.

Recent Progress

Modeling of thick sections laser peened from one side was successful. Figure 6 shows the residual stress profiles compared to experimental profiles at two different laser peening intensities. Model verification was based on the comparison of residual stress measurements performed on LSP'd coupons with those predicted by the model. The residual stress profiles developed in a part depend not only on the laser peening intensity, but also on the material and part geometry.

In addition, significant progress was made in defining the issues involved with modeling of residual stresses in thin sections, and determination of appropriate approaches to address these issues. Modeling of laser peening residual stresses in thin sections will not be possible until these issues are resolved.

Based on the modeling results, a follow-up task is needed to develop process optimization schemes to decrease the time and cost for process optimization. Funding sources are being sought for the follow-up effort.

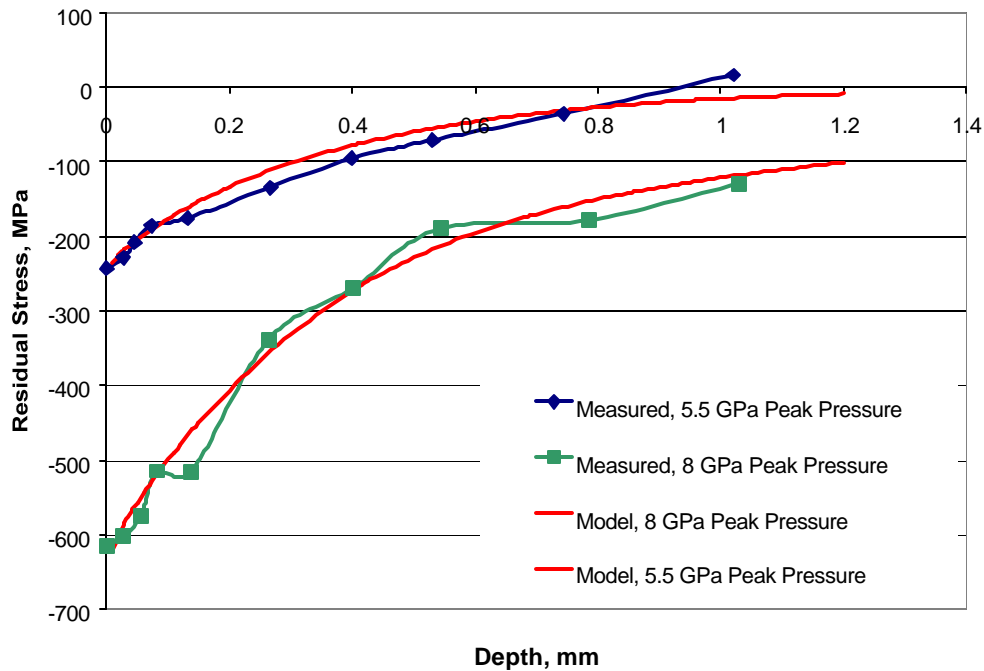

FIGURE 6. Comparison of Modeled and Experimental Residual Stresses for Similar Pressure Conditions

Participating Organizations: LSP Technologies, Inc., Ohio State University, University of Dayton Research Institute

Points of Contact:

Government

Mr. Joseph G. Burns
 U.S. Air Force
 AFRL/MLLN, Bldg. 655
 2230 Tenth St., Suite 1
 Wright-Patterson AFB, OH 45433-7817
 Phone: (937) 255-1360
 Fax: (937) 255-4840
 Email: Joseph.Burns@afrl.af.mil

Contractor

Dr. Allan H. Clauer
 LSP Technologies, Inc.
 6145 Scherers Place
 Dublin, OH 43016-1272
 Phone: (614) 718-3000 x12
 Fax: (614) 718-3007
 Email: aclauer@lspt.com

1.5 RapidCoater[®] for LSP FY 97-01

Introduction

One of the significant shortcomings of the current Laser Shock Peening process is slow processing, which is primarily due to the inability to apply and remove the opaque overlay (paint) rapidly. An opaque overlay is applied the surface of a part for two reasons, to protect the surface of the part from the intense heat of the plasma and to provide a consistent processing medium for the laser beam. The application of these overlays is a time-consuming, labor-intensive process. Current practice requires the application and removal of the paint outside of the laser workstation. Under current practice, a part that requires multiple shots must be transported back and forth several times, from the laser workstation where it is peened, to a separate area where the overlay is removed and reapplied, then back to the laser workstation, and so on. Sections 1.5.1 and 1.5.2 below explain what is being done to solve this problem. Section 1.5.1 describes the development, selection, and demonstration of a prototype system to rapidly apply and remove the overlay System. Section 1.5.2 describes the development of a production system.

Another source of slow processing is due to the shape of the laser beam spot on the surface to be processed. The current laser beam shape is round and as a result overlapping of the laser beam spots, up to 30 percent, is required to provide 100 percent laser shock peen coverage. Decreasing the overlap will increase the processing rates. Section 1.5.2 describes the development of laser beam optics to shape the round laser beam into a square laser beam.

The objective of this program is to develop and implement technologies that increase the rate of laser shock peening. The Points of Contact: and Participating Organizations listed below apply to both of these efforts.

Participating Organizations: LSP Technologies, Inc.

Points of Contact:

Government

Mr. David W. See
U.S. Air Force
AFRL/MLMP, Bldg. 653
2977 P Street, Suite 6
Wright-Patterson AFB, OH 45433-7739
Phone: (937) 255-3612
Fax: (937) 656-4420
Email: david.see@afrl.af.mil

Contractor

Dr. Allan H. Clauer
LSP Technologies, Inc.
6145 Scherers Place
Dublin, OH 43016-1284
Phone: (614) 718-3000 x12
Fax: (614) 718-3007
Email: aclauer@lspt.com

1.5.1 Rapid Overlay Concept Development

FY 97

Background and Final Results

The objective of this SBIR Phase I program was to identify and evaluate promising methods for applying and removing the opaque overlay rapidly during laser peening. Two coating application methods were investigated: (1) water-soluble paint applied with a spray gun, and (2) paint or ink application with an ink jet. The water-soluble paint/spray gun application method was selected as the most promising approach. The rapid overlay system concept was developed around this method. The rapid overlay demonstration test unit was assembled and tested to provide a working demonstration of the concept. The demonstration, which consisted of sequential application of the paint overlay, application of the overlay water film, firing the laser, and removal of the paint overlay in continuous, repetitive cycles, was successful. The successful demonstration system has been designated the RapidCoater™ System.

1.5.2 Development of a RapidCoaterä Manufacturing System

FY 98-01

Background

In Phase I of this program, it was demonstrated that it is possible to automate the application of the overlay while processing. The objectives of this Phase II program are to develop a rapid-overlay-application and removal system that will be integrated into a production laser peening system, develop a control system that will synchronize the coating process and interface it with the laser control system, and identify beam shaping optics to produce square laser beam spots. The production RapidCoater™ system should accommodate a range of parts and operate reliably at the laser repetition frequency. This will allow the RapidCoater™ system to be integrated into the production laser peening system.

An extension to this program was awarded that adds two additional objectives. One of these objectives is to develop controls and monitors that will monitor the quality of the overlays being applied by the RapidCoater™ system to the surface of the part being processed. The other objective is to develop techniques to rapidly set-up and calibrate the laser beam monitors and position of the laser beam on the part.

Recent Progress

In August 2000, the RapidCoater™ system was successfully demonstrated while processing a 1.5 inch by 0.75 inch patch on an F110 fan blade. A RapidCoater™ system with a dual-headed applicator applied paint to both sides of the fan blade is shown in Figure 7, allowing both sides of the fan blade to be processed at the same time. The application of the opaque and transparent overlays, paint and water, respectively, was synchronized with the laser. The paint was applied first followed by the overlay water and sufficient time was allowed for the overlay water to establish a uniform thickness and pattern over the applied paint. After the laser pulse was delivered and the shock wave propagated through the material, the wash water on the RapidCoater™ system was activated to remove the paint and prepare the surface for the next laser pulse application. This demonstration was conducted with the F110 fan blade at processing rate of 0.25 Hz, because the Manufacturing Cell 2 laser system is currently capable of delivering one laser pulse every 4 seconds. However, without the Manufacturing

Cell 2 laser, the RapidCoater™ system was demonstrated at a rate of 2 Hz while processing the same area on the F110 fan blade.

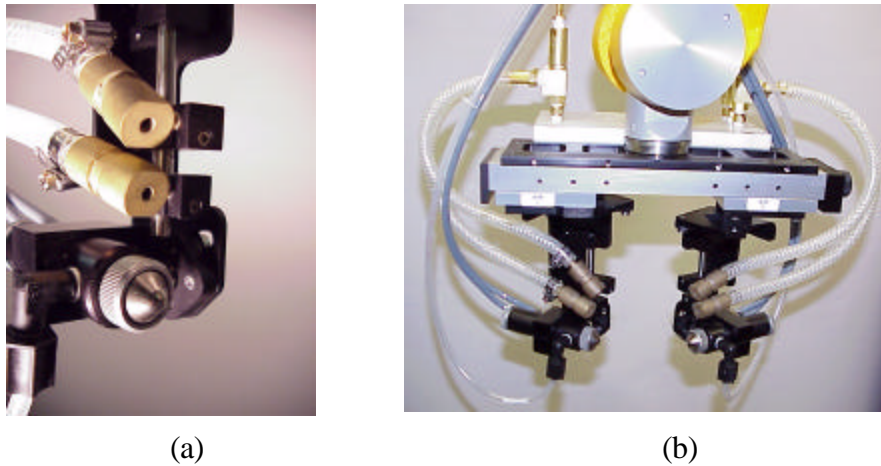

FIGURE 7. A Single RapidCoater™ Head (a) for Single-Sided Processing and a Dual RapidCoater™ Head, and (b) for Processing a Thin Section, Such as Compressor Blades

Laser peening rates are also a function of the laser beam spot shape. The current laser beam shape is round and as a result overlapping of the laser beam spots is required to provide 100 percent laser-shock-peen coverage. This overlap of the spots increases the processing time; however, if the spot shape is square, the processing rates can be significantly increased. Special optics has been evaluated to produce square spots. A square beam has been produced from a round beam as shown in Figure 9.

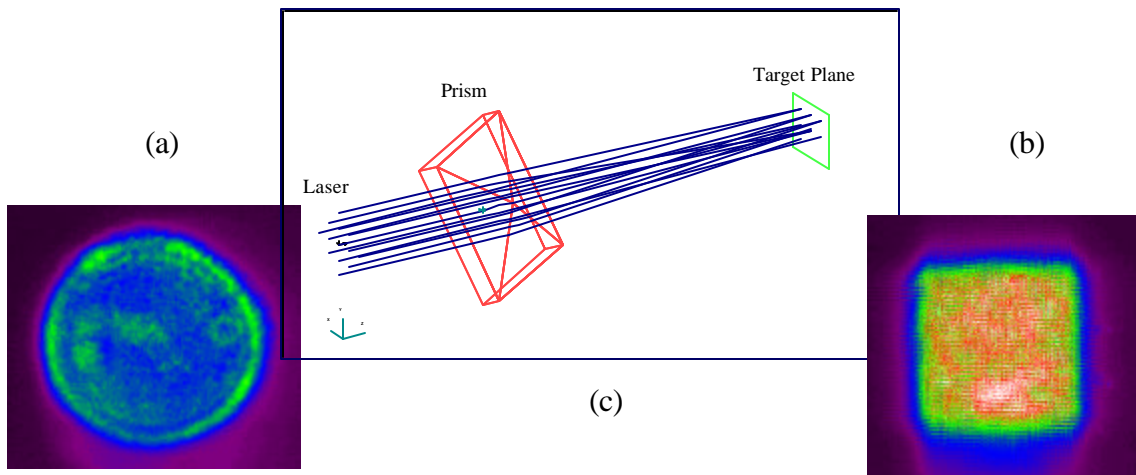

FIGURE 8. Spatial Profiles of the Laser Beam Showing the Transformation from a Round Spot (a) to a Square Spot (b) with the Use of Optics (c)

1.6 Manufacturing Technology for Affordable LSP

FY 98-02

Background

The technical challenges associated with this program are all related to scaling the technology of the prototype production facility into a full manufacturing facility. The program is focused on the development and implementation of new (or improved) controls and monitors into the manufacturing facility and is divided into three phases.

Phase I: The purpose of Phase I was to mitigate the risks associated with the transition to manufacturing. This phase is divided into three areas:

1. Development and testing of new (or improved) controls and monitors, which will be used to increase the process reliability and reduce processing costs. The primary monitors (energy, temporal profile, and spatial profile) typically used for laser peening have been enhanced. “Secondary” laser monitors, process monitors, and quality control monitors have been demonstrated and will be down-selected for implementation into the new manufacturing cell.
2. Development of prototype small-parts and large-parts peening cells. This effort began in the final quarter of calendar year 1998 and was successfully completed in early 2000.
3. Initial commercialization planning and new application development.

This phase is complete.

Phase II: Phase II is the final design and build phase for the laser and a small-parts peening cell. This phase is divided into two areas:

1. Design, fabrication, and integration of a manufacturing cell consisting of the laser system and a small-parts peening cell. This includes the down-selection and integration of the controls and monitors developed in Phase I.
2. Demonstration of the LSP manufacturing cell. The demonstration is currently scheduled for October 2001.

Phase III: Phase III is the commercial development phase. The objective is to develop the new applications identified in Phase I and demonstrate laser shock peening to the appropriate market sectors that include the aerospace, medical, and automotive sectors. This phase began in January 2000.

Recent Progress

Phase I. Great progress has been made in completing this phase. The primary laser controls, which consist of the laser beam energy, temporal profile, and spatial profile, have been redesigned to be more robust. Additionally, new laser monitors have been developed to monitor the “health” of the laser. These new monitors include: monitoring the flashlamps to ensure that they are operating properly, monitoring energy reflected back from the part being processed (target backscatter), and monitoring critical optical components to ensure that they are not degrading.

A robust off-the-shelf distributed control network has been identified and successfully tested. This distributed control network has been incorporated into the design for the new laser system.

Two prototype peening-cells, a small-parts cell and a large-parts cell, were completed and evaluated by the program team in April 2000. The small-parts peening cell, which was based upon the original peening cell already in place at LSPT, includes an improved beam delivery system, a more robust beam monitoring configuration, and a more robust processing chamber. The large-parts cell will be used for production laser peening of F119 integrally bladed rotors (IBRs) in early 2001.

Market surveys have been completed and a commercialization plan has been developed based upon these data. This commercialization plan was delivered to the Air Force in June 2000 and is currently being implemented.

Phase II. The work in this phase is on schedule and the status is as follows:

- The laser design is complete.
- Fabrication of the laser is underway.
- Non-Destructive Evaluation (NDE) effort is underway.
- Evaluation of new controls and monitors continues.

Assembly of the pulse-forming networks (PFNs), as shown in Figure 9, is complete and the assembly of the laser is underway as shown in Figure 10. The bulk of the remaining work is related to the assembly and fabrication of the laser and the associated peening cells. Mechanical and electric assembly will be completed in the second quarter of 2001. The system will be operational in the fourth quarter of 2001.

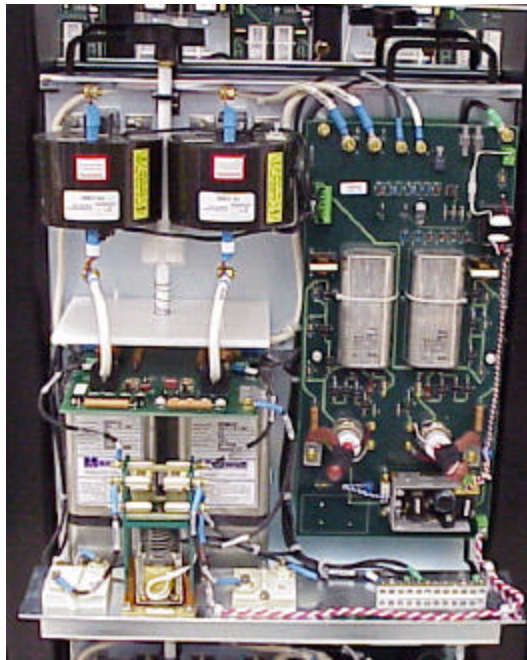
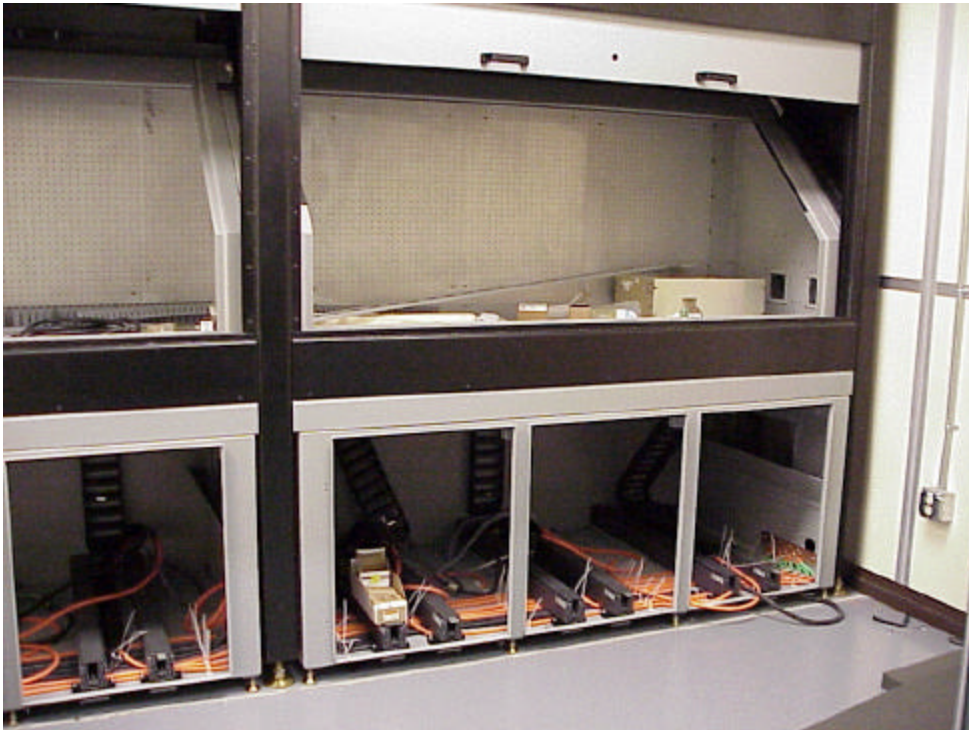

FIGURE 9. One of 48 PFNs That Are Being Integrated into the Laser System



(a)



(b)

FIGURE 10. The PFN bays are located under the optical table. Electrical wiring to power the PFNs is in progress (a) and the drawers to support them have been constructed (b).

Participating Organizations: LSP Technologies, Inc.

Points of Contact:

Government

Mr. David W. See
U.S. Air Force
AFRL/MLMP, Bldg. 653
2977 P Street, Suite 6
Wright-Patterson AFB, OH 45433-7739
Phone: (937) 255-3612
Fax: (937) 656-4420
Email: david.see@afri.af.mil

Contractor

Dr. Jeff L. Dulaney
LSP Technologies, Inc.
6145 Scherers Place
Dublin, OH 43016-1284
Phone: (614) 718-3000 x11
Fax: (614) 718-3007
Email: jdulaney@lspt.com

1.7 Laser Peening of F119 Fourth-Stage Integrally Bladed Rotors *FY 00-01*

Background

This program is in support of the F-22 System Program Office, which has an immediate need to solve laser shock peening production difficulties with the fourth-stage integrally bladed rotors (IBRs) on the F119 engine. There is a need to apply laser shock peening to the trailing edge of the airfoils to meet the fatigue strength requirements of the airfoils. Laser shock peening is a repeatable manufacturing process that has wide application to many different types of gas turbine engine parts, but is currently being used in production only on individual blades.

Air Force Manufacturing Technology Directorate is providing specific technology for insertion into the production manufacturing process for the fourth-stage F119 IBR, which includes an automated overlay applicator, controls and monitors for ensuring that the process remains within operating parameters, and image processing methods to ensure proper positioning of the laser beam on the airfoil.

There are two primary program goals:

1. To get the time to LaserPeen™ process a fourth-stage F119 IBR to less than eight hours. It is currently estimated to take more than 40 hours of processing time to laser shock peen all of the airfoils on a fourth-stage F119 IBR.
2. To reduce the laser shock peening costs by at least a factor of four.

The program is divided into five tasks:

Task 1: RapidCoater™ Overlay Applicator Design and Implementation.

The current RapidCoater™ design will be modified to accommodate the specific geometry of the F119 fourth-stage IBR. The modified design shall be fabricated, tested, and optimized for the F119 fourth-stage IBR.

Task 2: Production Hardening the IBR Cell.

The existing prototype large-parts peening cell will be modified to meet Pratt & Whitney's production requirements for the F119 fourth-stage IBR.

Task 3: Quality Control (QC) and Quality Assurance (QA) Controls & Monitors.

QC and QA controls & monitors currently available in the small-parts peening cell will be integrated and adapted into the IBR cell. Additionally, an automated laser-beam-energy calibration system shall be implemented into the IBR cell.

Task 4: Fully Integrate the IBR Cell into the Manufacturing Cell.

All aspects of integrating the IBR cell into the new manufacturing cell will be addressed in this task, including mechanical, electrical, computer, and optical interfaces.

Task 5: Implement an Airfoil-Edge Tracking System.

The purpose of this task is to implement a system that will ensure that the laser beams are properly aligned onto the airfoils for laser peening.

Recent Progress

Several IBRs have been laser peened in the IBR cell for evaluation and testing purposes (Fig. 11). Production laser peening of IBRs will begin in early 2001.

Significant progress has been made in completing each of the planned tasks. A prototype RapidCoater™ unit for IBRs has been designed, fabricated, and is being tested. The robot to manipulate the RapidCoater™ head has been delivered and tested. The IBR cell has been modified to improve robot-positioning capability. Additional cell improvements, QA & QC monitors, and the airfoil edge-tracking system are under design. The program is on schedule for an October 2001 completion.

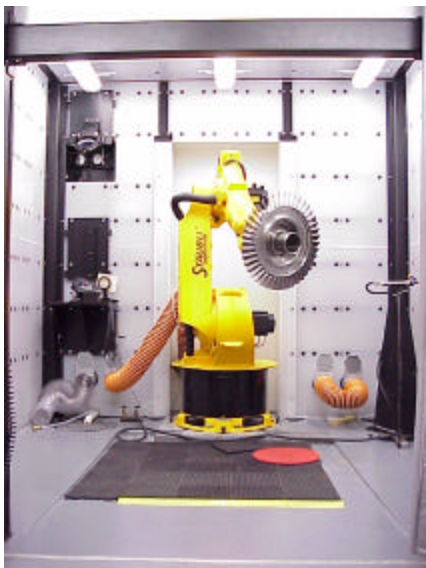

(a)



(b)

FIGURE 11. Two LSP'd IBRs: (a) A Fourth-Stage Compressor IBR and (b) a First-Stage Fan IBR for the F119 Engine

Participating Organizations: LSP Technologies, Inc.

Points of Contact:

Government

Mr. David W. See
U.S. Air Force
AFRL/MLMP, Bldg. 653
2977 P Street, Suite 6
Wright-Patterson AFB, OH 45433-7739
Phone: (937) 255-3612
Fax: (937) 656-4420
Email: david.see@afrl.af.mil

Contractor

Dr. Jeff L. Dulaney
LSP Technologies, Inc.
6145 Scherers Place
Dublin, OH 43016-1284
Phone: (614) 718-3000 x11
Fax: (614) 718-3007
Email: jdulaney@lspt.com

1.8 Small Engine LSP

FY 03-04

This proposed future effort is in the early planning stage.

1.9 Conclusion

The Component Surface Treatment Action Team demonstrated Laser Shock Peened (LSP'd) damaged turbine engine fan blades that had equal or better high cycle fatigue strength than undamaged unpeened blades; completed testing that showed the ability of the LSP process to stop both HCF crack initiation and propagation in these fan blades; demonstrated the complete LSP system (laser, facility, and more affordable process) with the prototype now available for government and industry use; and successfully transitioned the LSP technique to F101 and F110 engines. This has resulted in 15x increase in FOD tolerance for these engines, and major reduction in inspection man-hour costs, with increased flight safety. Due to the excellent progress to-date, all engine contractors are now pursuing LSP approaches. Further cost reduction of the manufacturing facilities and processes for the LSP technique is now the major focus of this team. Engine manufacturers are currently pursuing LSP on fan and compressor integrally bladed rotors (IBRs) and blisks.

The ultimate objective of the Component Surface Treatment Action Team and of all the efforts described in this section is to develop an affordable Laser Shock Peening system. The relationship of all these efforts is shown below in Figure 12.

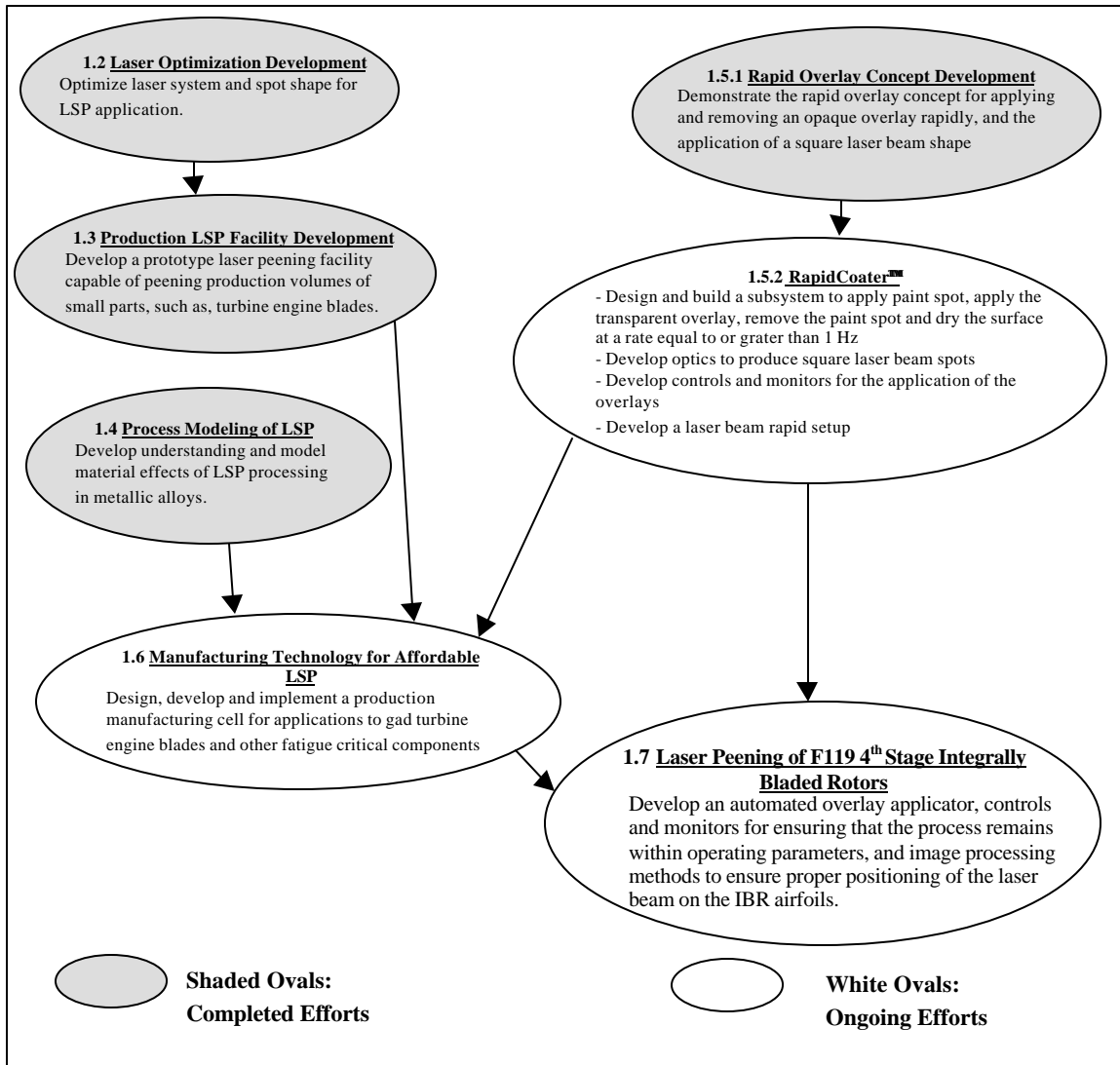

FIGURE 12. Interrelationship between LSP Programs

2.0 MATERIALS DAMAGE TOLERANCE



BACKGROUND

The Materials Damage Tolerance Research Action Team (Materials AT) is responsible for fostering collaboration between individual HCF materials damage tolerance research efforts, with the goal of reducing the uncertainty in the capability of damaged components by 50%. The Materials AT will provide technical coordination and communication between active participants involved in HCF life prediction, damage nucleation and propagation modeling, fracture mechanics methodology development, residual fatigue capability modeling, and the evaluation of surface treatment technologies. Annual technical workshops will be organized and summaries of these workshops will be disseminated to appropriate individuals and organizations. The Chair, Co-Chair, and selected Materials AT members will meet as required (estimated quarterly) to review technical activities, develop specific goals for materials damage tolerance research projects, and coordinate with the Technical Planning Team (TPT) and the Industry Advisory Panel (IAP). The Chairman (or Co-Chair) of the Materials AT will keep the TPT Secretary informed of AT activities on a frequent (at least monthly) basis. This AT will include members from government agencies, industry, and universities who are actively involved in materials damage tolerance technologies applicable to turbine engine HCF. The team is intended to be multidisciplinary with representatives from multiple organizations representing several component technologies as appropriate. The actual membership of the AT will change as individuals assume different roles in related programs.

ACTION TEAM CHAIRS



Chair

Dr. Jeffrey R. Calcaterra
U.S. Air Force
AFRL/MLLMN, Bldg. 655
2230 Tenth St., Suite 1
Wright-Patterson AFB, OH 45433-7817
Phone: (937) 255-1360
Fax: (937) 656-4840
Email: jeffrey.calcaterra@afrl.af.mil



Co-Chair

Lt Brett Conner
U.S. Air Force
AFRL/MLLMN
2230 Tenth St., Suite 1
Wright-Patterson AFB, OH 45433-7817
Phone: (937) 255-1348
Fax: (937) 656-4840
Email: brett.conner@afrl.af.mil

INTRODUCTION

Prior to this research program, no accurate techniques were available to determine the capability of materials subjected to variations in manufacturing, component handling, and usage. Such techniques are needed for accurate life prediction and optimized design to assure damage tolerance. The following pages summarize the schedules, backgrounds, and recent progress of the current and planned projects managed by this action team.

Materials Damage Tolerance Research Schedule

Product	FY96	FY97	FY98	FY99	FY00	FY01	FY02	FY03	FY04	FY05	FY06
2.1 Microstructure Effects of Titanium HCF (Fan)	█										
2.2 Air Force In-House Research (Fan & Turbine)	█										
2.3 HCF & Time-Dependent Failure in Metallic Alloys for Propulsion Systems (Fan & Turbine)	█										
2.4 Improved HCF Life Prediction (Fan)	█										
2.5 Advanced HCF Life Assurance Methodologies				█							
2.6 Future Efforts											
2.6.1 Probabilistic HCF Life Prediction						█					
2.6.2 Advanced High Cycle Fatigue Mechanics							█				
2.6.3 HCF Properties of Welds on Nickel-Based Alloys							█				

2.1 Microstructure Effects of Titanium HCF (Fan)

FY 96-98

Background

The objective of this project was to determine the relationship between mean stresses and high cycle fatigue strength for Ti-6Al-4V by correlating the fatigue crack nucleation process with the cyclic deformation behavior of the alloy for different microstructures and crystallographic texture characteristics. A workable hypothesis that was investigated was that high mean stress fatigue life sensitivity is associated with cyclic softening of Ti-6Al-4V, which in turn results in the absence of an endurance limit. In addition to establishing such a correlation, the second purpose of the investigation was to study the crystal orientation dependence on, and the microstructural features that affect, the cyclic deformation behavior. The specific factors that control crack nucleation are also being studied. The focus is on the formation of dislocation substructure and the statistical nature of crack formation. Analytical procedures emphasize the use of quantitative physical models that can be used to predict the mean stress sensitivity in this class of titanium alloys. The results should also be useful in the search for the best alloy/process for maximizing fatigue resistance in engineering structures.

Final Results

The findings of the two aspects of the physical behavior of Ti-6Al-4V that were investigated are described below. These findings contributed to the development of a model to predict the mean stress sensitivity of Ti-6Al-4V, which is also described below.

Correlation of Cyclic Softening and the Absence of an Endurance Limit. Cyclic strain tests in strain control mode did not reveal significant differences in cyclic deformation behavior between the investigated microstructures (lamellar cross-rolled, bimodal fine uni-rolled, bimodal coarse cross-rolled, bimodal coarse forged, equiaxed coarse cross-rolled, and equiaxed coarse forged). All six microstructures underwent cyclic softening, and the saturation stresses at all strain levels (and hence, cyclic stress-strain curves) were almost identical for all of these microstructures. However, in the initial condition (monotonic stress-strain curve), the differences in saturation stresses were much greater. Unlike S-N (stress-life) curves, little difference was observed between the ϵ -N (strain-life) curves generated for each of the investigated microstructures, especially at low strains. Also, relatively little scatter was observed for each curve.

Effect of Crystal Orientation and Microstructural Features on Fatigue Behavior. Of the six microstructure/texture combinations investigated, bimodal fine uni-rolled and lamellar cross-rolled displayed superior fatigue properties to the remaining four microstructures (bimodal coarse cross-rolled, bimodal coarse forged, equiaxed coarse cross-rolled, and equiaxed coarse forged). Bimodal fine uni-rolled and lamellar cross-rolled microstructures exhibited Goodman dependence of fatigue strength, while the other four microstructures had anomalous mean stress dependence, with fatigue strength values at intermediate mean stresses being considerably lower than predicted by the Goodman relation.

Analytical Procedures (Models) to Predict Mean Stress Sensitivity. The fatigue data collected in this project have been statistically analyzed to develop a model to predict the effects of microstructure and texture on the fatigue strength of α/β titanium alloys. This effort resulted in a model that allows the accurate prediction of fatigue curves for titanium alloys from microstructure and texture characteristics at different R ratios ($\sigma_{\min}/\sigma_{\max}$). Separate models have been developed for low cycle and high cycle

fatigue regimes, and for three ranges of R: $R < 0$ (tensile-compressive loading), $0 \leq R \leq 0.5$ (tensile-tensile loading) and $0.5 < R \leq 0.7$ (creep-fatigue interaction). For each of these regimes, fatigue strength is calculated as a function of alpha grain size d_α , transformed beta volume fraction v_β , texture orientation parallel to test direction X_α , ultimate tensile strength U, and ductility (reduction of area) e_f . Figure 13 demonstrates how the model (presented with solid curves) fits actual data points for three different microstructures at $R=0.1$. The following equations were used to construct these curves:

1. Low Cycle Fatigue (LCF) regime, $0 \leq R \leq 0.5$

$$\sigma_L = 101.457 + 5.565 v_\beta + 21.562 \sqrt{d_\alpha} - 44.629 e_f - 1.077 X_\alpha - 6.227 \sqrt{d_\alpha} \log N - 0.21 U R$$

2. HCF regime, $0 \leq R \leq 0.5$

$$\sigma_H = 91.859 + 10.427 v_\beta - 8.529 \sqrt{d_\alpha} - 5.208 \log N - (10.684/\sqrt{d_\alpha} + 0.164 U) R$$

where: d_α = alpha grain size, μm
 v_β = transformed beta volume fraction
 X_α = texture orientation parallel to test direction (x random)
U = ultimate tensile strength (Ksi)
 e_f = ductility (reduction of area)
N = number of cycles
R = stress ratio ($\sigma_{\min}/\sigma_{\max}$)

The model was tested on the investigated microstructures, and accurately predicted the fatigue strength of α/β titanium alloys for the following range of parameters:

$d_\alpha = 3\text{-}16 \mu\text{m}$
 $v_\beta = 0.15\text{-}0.80$
 $X_\alpha = 4\text{-}13$
U = 138-173 Ksi
 $e_f = 0.30\text{-}0.55$

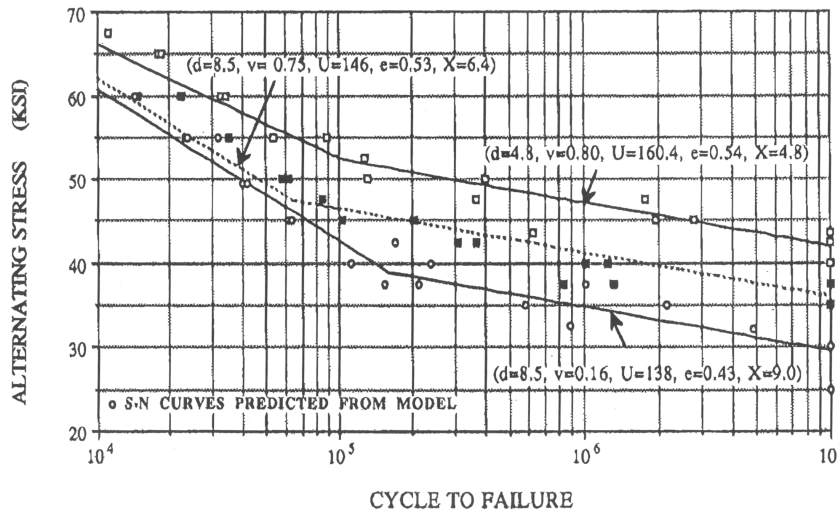

FIGURE 13. S-N Input Data and Fatigue Strength Model Results for Bimodal Fine Uni-Rolled, Bimodal Forged, and Equiaxed Forged Microstructures (Top to Bottom) at $R=0.1$

Participating Organizations: Air Force Office of Scientific Research (AFOSR), Worcester Polytechnic Institute, Pratt & Whitney

Points of Contact:

Government

Dr. Spencer Wu
U.S. Air Force, AFOSR/NA
110 Duncan Ave., Suite B115
Bolling AFB, DC 20332-8080
Phone: (202) 767-4989
Fax: (202) 767-4988
Email: spencer.wu@afosr.af.mil

Contractor

Prof. Richard D. Sisson, Jr.
Worcester Polytechnic Institute
Mechanical Engineering Department
100 Institute Road
Worcester, MA 01609
Phone: (508) 831-5335
Fax: (508) 831-5178
Email: sisson@wpi.edu

2.2 Air Force In-House Research (Fan & Turbine) *FY 96-03*

Background

The objectives of this program are as follows:

- (1) Conduct breakout research on titanium and nickel-base superalloys.
- (2) Explore high cycle fatigue related damage mechanisms, including the determination of the relative significance of specific damage mechanisms and the identification of specific areas requiring a concentrated research and development effort for incorporation into the HCF design system.
- (3) Develop innovative test techniques and modeling concepts to guide the industry research program.
- (4) Conduct research and evaluation to demonstrate and validate damage tolerance design methodologies for HCF.

Recent Progress

During the past year, progress has been made in all areas. The following paragraphs highlight specific accomplishments with regard to the approaches being taken in this task.

- ❖ ***Material Behavior for Modeling.*** Testing has been accomplished to generate valid data for modeling the damage mechanisms associated with high cycle fatigue interaction with low cycle fatigue, fretting fatigue, and foreign object damage (FOD).
 - ***High Cycle Fatigue / Low Cycle Fatigue Interaction.*** Load history effects on fatigue crack thresholds were evaluated using both load shed and step testing. The difference between the two techniques is that load shedding reduces the effect of load history while step testing does not. Prior load history effects were investigated by measuring threshold values where overload LCF precracking is used prior to step testing (Fig. 14).

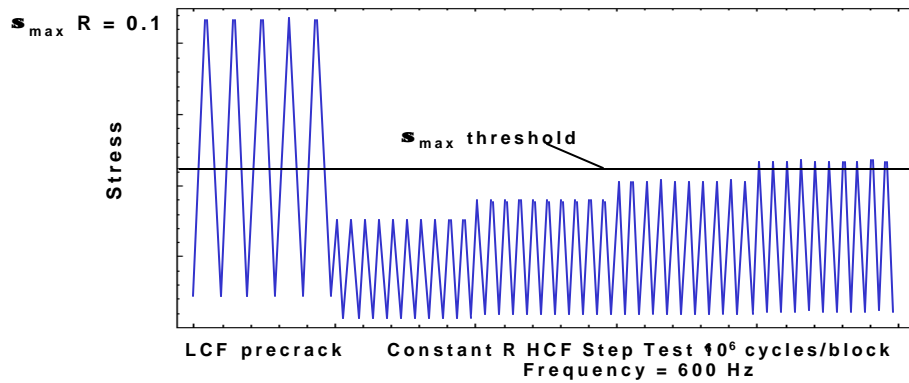

FIGURE 14. Pre-Crack and Step-Test Loading Technique Used to Determine LCF/HCF Thresholds

The threshold ΔK (ΔK_{th}) data from the step tests follow a linear trend with precracking ΔK (ΔK_{pc}). A simple overload model, shown below, was developed to formulate a relationship between ΔK_{th} and ΔK_{pc} :

$$\Delta K_{th} = \frac{(1 - R_{th})\Delta K_{eff}^{th}}{(1 - \hat{a}R_{th})} + \frac{(1 - R_{th})\hat{a}}{(1 - \hat{a}R_{th})(1 - R_{pc})} \Delta K_{pc},$$

where $\Delta K_{eff}^{th} = K_{max}^{th} - K_r$, and $K_r = \hat{a}(K_{max}^{pc} + K_{min}^{th})$, and the threshold data at $R=0.1$ are used to determine the model constant, β . Given the model constant, the model predicts the threshold data at $R=0.3$, $R=0.5$, and $R=0.7$ in Ti-6-4 and $R=0.5$ and $R=0.7$ in Ti-17 quite well (Fig. 15).

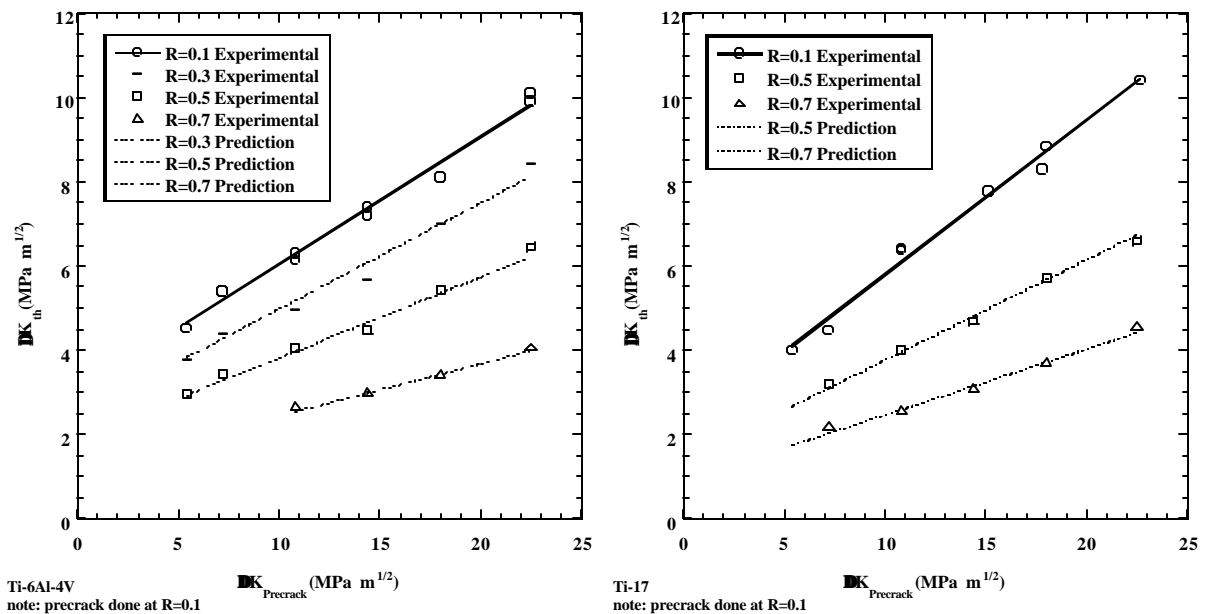

FIGURE 15. Model Correlation for Ti-6Al-4V and Ti-17 for Different Values of Stress Ratio, R

- In addition to load history effects, a true material threshold was determined both in Ti-6-4 and Ti-17 using stress relief annealing and step testing. Test data show that these threshold values are slightly lower than threshold values that have been measured using the load shedding process, which may not remove all history effects. Regardless of the loading history, the stress relief annealed step test produces consistent load-history-free ΔK_{th} data (Fig. 16). A simplification of the model can be used to determine the true material threshold without stress relief annealing. The true material threshold is then a baseline threshold, which can be used to determine threshold values depending on the load history. The extension of these concepts to a broader range of LCF precrack histories is yet to be established.

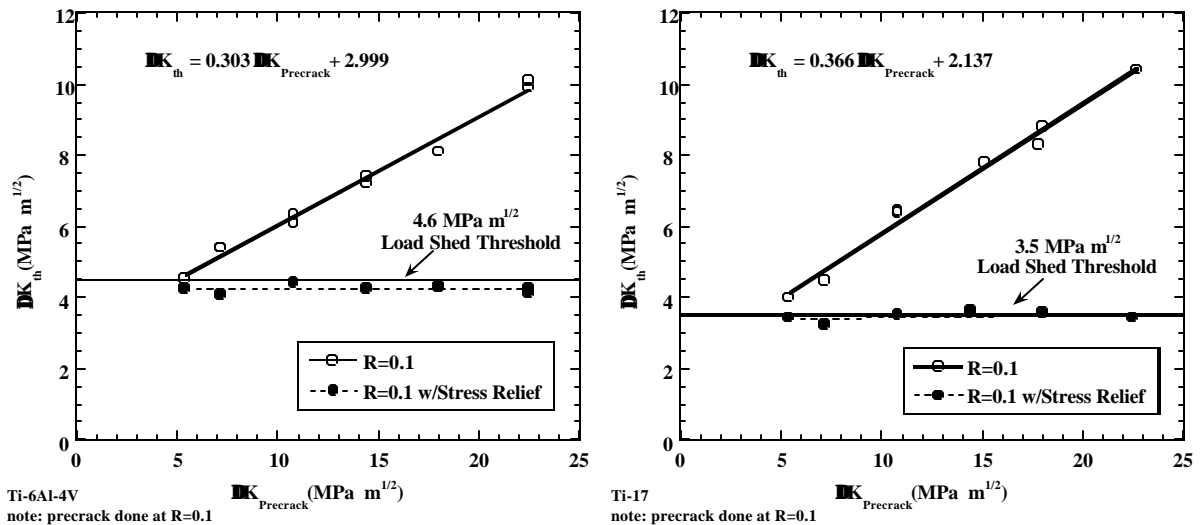

FIGURE 16. Stress-relieved Threshold Crack Growth Values for Ti-6Al-4V and Ti-17 Fatigued at R=0.1

- *HCF Fretting Fatigue.* Four studies and a modeling effort on fretting fatigue are being accomplished in this program:
 - Thin plate samples of Ti-6Al-4V gripped on both sides with pads of the same material were used to simulate contact conditions in structures subjected to fretting fatigue. Laboratory tests on specimens of varying thicknesses were used to determine the stresses that correspond to a fatigue life of 10^7 cycles using a step-loading procedure. For the specific apparatus used in this study, changes in thickness produced changes in the ratio of shear load to clamping load for a specific fretting pad geometry. Specimen thicknesses of 1 mm, 2 mm, and 4 mm, and stress ratios of $R = 0.1$ and $R = 0.5$ were investigated for two different contact pad lengths. Fatigue limit stresses in the specimen were found to be relatively insensitive to the average clamping or shear stress. Finite element analyses of the test geometry were used to provide details of the stress distribution in the contact region for the flat-on-flat geometry with blending radius. Results show that stress and displacement fields for a variety of test conditions corresponding to a fatigue life of 10^7 cycles vary widely and do not provide any clear indication of the existence of a simple parameter equivalent to a uniaxial fatigue limit stress. The stress and displacement fields are also shown to be very sensitive to the coefficient of friction used in the analysis.

Within the constraints of the geometry and test configuration and loading conditions examined in this investigation, and under the assumptions made in the analyses, particularly that of the coefficient of friction being 0.3, the following conclusions can be drawn:

1. The fatigue limit stress corresponding to 10^7 cycles, under fretting fatigue, is only 20 to 40 percent of that of a smooth bar. Thus, fretting fatigue is highly detrimental to the fatigue properties of Ti-6Al-4V.
 2. The debit in fatigue limit stress is relatively insensitive to the average shear stress or average clamping stress.
 3. Stress and relative displacement (slip) fields are very sensitive to the value of the coefficient of friction chosen for analysis.
 4. Stress and slip fields, determined under a range of conditions which each correspond to a fretting fatigue life of 10^7 cycles, show no obvious pattern from which a fatigue limit criterion can be deduced.
- Elastic-plastic finite element analyses (FEA) have progressed from cylinder-on-flat simulations to two-dimensional models of experimental hardware. FEA models consisted of flat pads with rounded edges contacting flat plates. The length of the flat pad section was either 19.05 mm or 6.35 mm, depending on the experimental setup. Flat plate thickness was varied between 1 and 4 mm, and values of normal load and axial fatigue force were matched with experimental conditions. The coefficient of friction was 0.3 for all simulations. Cyclic, interfacial stresses and slips were analyzed in detail. The amplification of the remotely applied cyclic stress in the contact region was shown to provide a rationale for the effect of contact pressure and stress amplitude on life. However, no single stress-based or displacement-based parameter was found to be useful for predicting fretting fatigue lives. Studies investigating the development of a useful fretting fatigue parameter are ongoing.
 - A novel procedure has been developed to characterize the threshold behavior of fretting fatigue cracks. The procedure involves machining fretting pads from fretting fatigue experiments into non-standard crack growth specimens, (Fig. 17). The specimens are then fatigued using step load techniques to determine the failure threshold. Results from these experiments are shown in Figure 18.

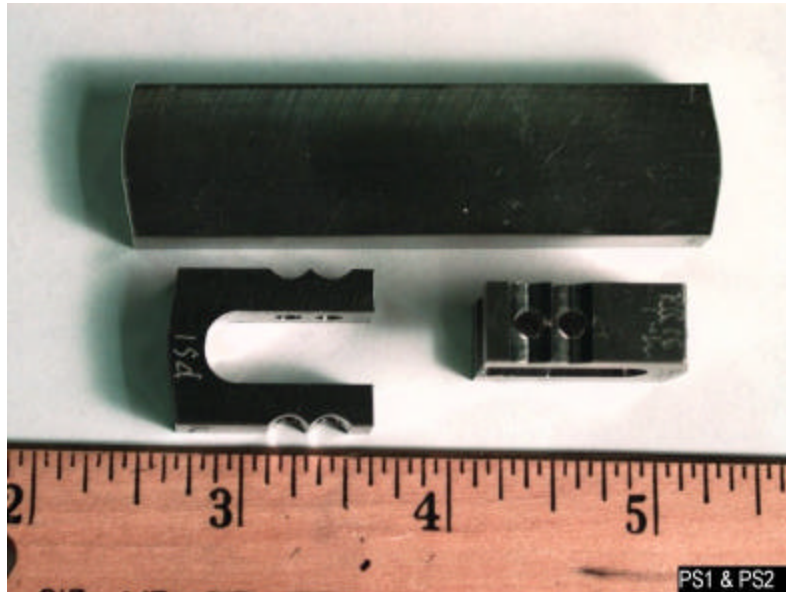

FIGURE 17. Fretting Pad (top) and Non-Traditional “Golden Arch” Specimens (bottom)

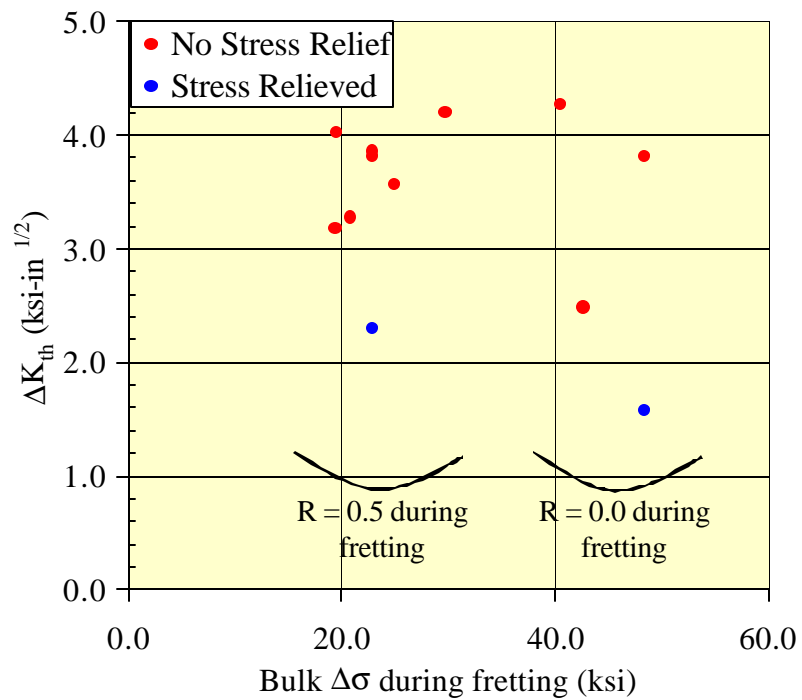

FIGURE 18. Fatigue Crack Threshold Values for Pads Exposed to Different Fretting Fatigue Conditions

As can be seen in the above figure, the complex load history experienced by these specimens has a beneficial effect on crack growth. Without stress relief annealing, ΔK_{th} has values between 2.8 and 4.6 $\text{MPa}\sqrt{\text{m}}$. This is very consistent with fatigue crack threshold values for naturally-initiated small cracks (detailed later in this report). However, when the specimens are stress relief annealed, the beneficial load history is removed and ΔK_{th} drops to between 1.8 and 2.5 $\text{MPa}\sqrt{\text{m}}$. This is much lower than previously reported small crack threshold values. The reason for this discrepancy is currently under investigation.

- The effect of TiCN, CrN + MoS₂ and copper-based palliative coatings on fretting fatigue behavior of Ti-6Al-4V has been evaluated. Evaluations were based on the ability of the coating to reduce the coefficient of friction (μ) and the coating durability. TiCN was found to have little effect on μ and very poor durability. CrN + MoS₂ reduced the uncoated coefficient of friction by one order of magnitude. However, this coating demonstrated poor durability and was completely removed after 2% of cyclic life. The copper-based coating only reduced μ 4x-5x, but demonstrated good durability. Additionally, the copper-based coating seems to have a significant self-lubricating, showing no significant degradation in effectiveness over 12,000 cycles (Fig. 19). Studies are ongoing to extend the evaluation to other coating systems and longer cyclic lives.

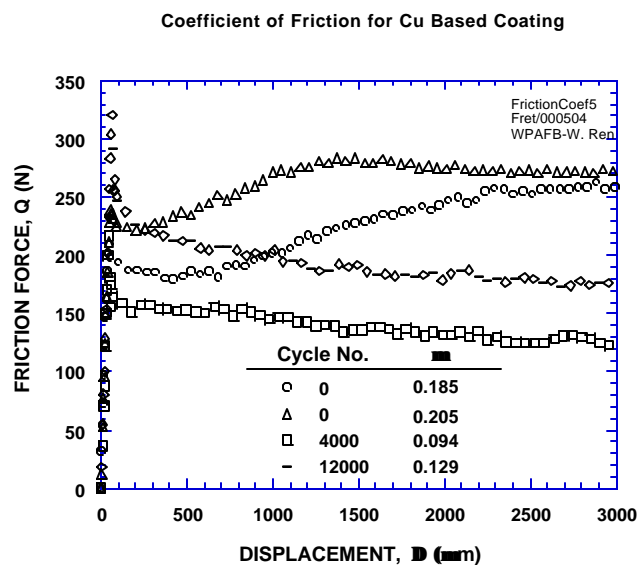

FIGURE 19. Cyclic Evolution of Friction Force for Copper-Based Coating System

- *HCF and Foreign Object Damage.* Previous work dealing with the effect of FOD on HCF properties has focused on the effect tensile residual stresses on fatigue life. This work was continued with increased emphasis on notch and specimen geometry.

Both real and simulated impacts were conducted using spherical projectiles launched at 300 m/s and quasi-static chisel indentation, respectively. The spheres used were 1-mm diameter glass beads, while the quasi-static indenter had a radius of 1 mm. The airfoil specimens had leading edge radii of either 0.13 or 0.38 mm and were indented at 30° to the airfoil leading edge. The rectangular plates were 1.25 mm thick and were indented quasi-statically at 0°. All

specimens subjected to FOD were subsequently tested in uniaxial HCF at a frequency of 350 Hz, using a step loading procedure to determine the fatigue limit corresponding to 10^7 cycles. Before the HCF testing, half of the specimens were stress relief annealed to remove residual stresses. The effect of the FOD-induced notches on the fatigue limit stress can be seen in Figure 20.

Figure 20 includes all data from the simulated airfoil specimens. It is evident from this figure that relieving residual stresses increases the overall fatigue lives. This indicates that the tensile residual stresses in the region deformed by impact are detrimental to fatigue lives. In fact, only as-received specimens failed below the limits established by standard notch analysis.

Notch geometry was studied using the flat bar specimens. In this case, notches were created using a static indenter. Most of the resulting damage had smooth notch roots. However, there were some cases where the notch lost material as a result of chipping. This resulted in an irregular notch geometry. The chipped notches had a much greater impact on fatigue life than smooth ones, as shown in Figure 21.

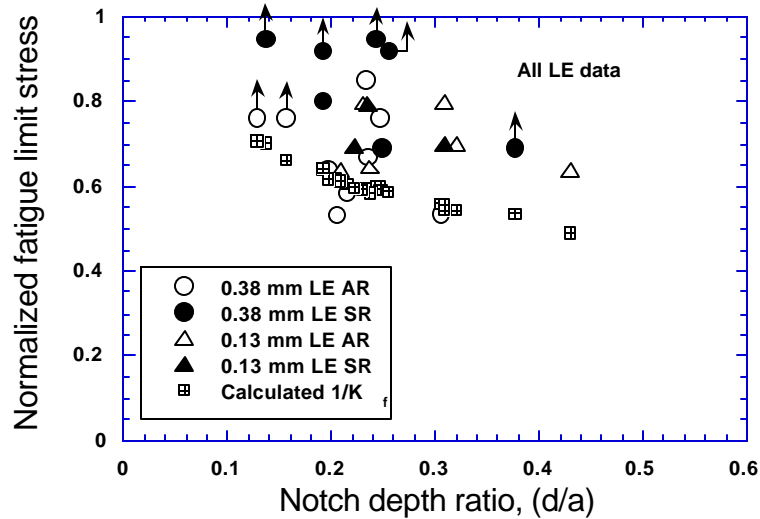

FIGURE 20. The Effect of Notch Depth Ratio on Normalized Fatigue Limit Stress. AR Denotes As Received and SR Denotes Stress Relieved. Arrows Indicate Failure Away from Notch.

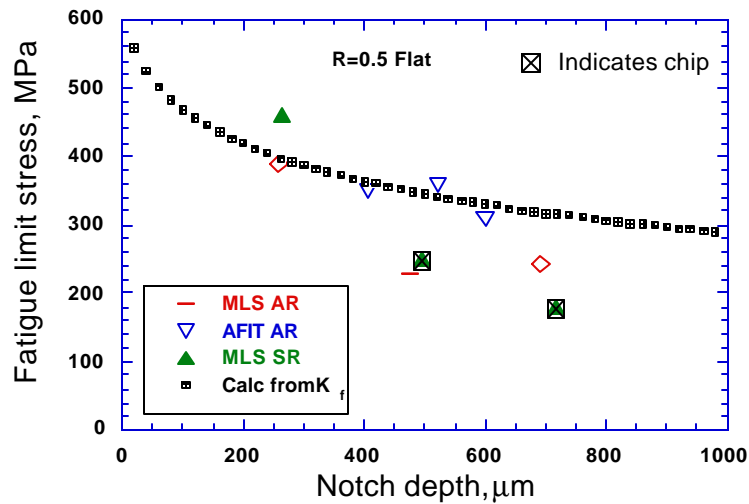

FIGURE 21. The Effect of Irregular (Chipped) Notches on Fatigue Limit Stress

In all flat bar cases involving smooth notch roots, stress relieved specimens had a much higher fatigue limit stress for similar notch roots. This suggests the debit caused by specimen chipping is a result of the geometry of the chip. These results may be useful for increasing engine FOD repair limits, particularly if the FOD damage site can be blended away.

- ❖ ***Innovative Test Technique Development.*** Experiments are being conducted to validate a dovetail geometry fretting fatigue fixture. The purpose of the study is to examine realistic fretting fatigue at or near the engineering endurance limit defined by 10^7 cycles. The fretting fatigue fixture permits contact between a dovetail type specimen and interchangeable pads of several different geometries. The ability to interchange pad geometry allows examination of several different complex contact stress conditions to occur. The dovetail geometry results in cyclical normal and shear loads, unlike conventional fretting fatigue fixtures, where normal load is kept constant. The complex loading will help determine if contact fatigue crack initiation and life prediction models are robust. Currently, tests are being conducted at a load ratio of 0.1 and a frequency of 30 Hz on specimens and pads made of solution-treated and overaged Ti-6Al-4V. The fixture is designed to be compatible with HCF shaker load frames, and future tests will be conducted at 300 Hz. Recent test results have demonstrated that cracks can initiate in the specimen and propagate to failure (Fig 22). Further tests are being conducted to ensure that contact dimensions match analytical predictions, and that the contact conditions are repeatable



FIGURE 22. Different Levels of Damage In Dovetail Fatigue Specimens

Participating Organizations: Air Force Research Laboratory (AFRL); University of Dayton Research Institute; Systran Corporation; Southern Ohio Council on Higher Education; University of Portsmouth, United Kingdom; Air Force Institute of Technology

Points of Contact:

Government

Dr. Theodore Nicholas
U.S. Air Force
AFRL/MLLMN, Bldg. 655
2230 Tenth St., Suite 1
Wright-Patterson AFB, OH 45433-7817
Phone: (937) 255-1347
Fax: (937) 656-4840
Email: theodore.nicholas@afrl.af.mil

Government

Dr. Jeffrey R. Calcaterra
U.S. Air Force
AFRL/MLLMN, Bldg. 655
2230 Tenth St., Suite 1
Wright-Patterson AFB, OH 45433-7817
Phone: (937) 255-1360
Fax: (937) 656-4840
Email: jeffrey.calcaterra@afrl.af.mil

2.3 HCF & Time-Dependent Failure in Metallic Alloys for Propulsion Systems (Fan & Turbine)

FY 96-01

Background

This program is focused on the definition, microstructural characterization, and mechanism-based modeling of the limiting states of damage associated with the onset of high cycle fatigue failure in titanium and nickel-base alloys for propulsion systems. Experimental and theoretical studies are aimed at three principal areas: high cycle/low cycle fatigue interaction, foreign object damage, and fretting. The goal of this program is to provide quantitative physical/mechanism-based criteria for the evolution of critical states of HCF damage, enabling life prediction schemes to be formulated for fatigue-critical components of the turbine engine. The specific objectives are as follows:

- (1) Perform systematic experimental studies to define crack formation and lower-bound fatigue thresholds for the growth of “small” and “large” cracks at high load ratios and high frequencies, in the presence of primary tensile and mixed-mode loading
- (2) Define lower-bound fatigue thresholds for crack formation in the presence of notches, fretting, or projectile damage, on surfaces with and without surface treatment (e.g., shot or laser shock peened).
- (3) Develop an understanding of the nature of projectile (foreign object) damage and its mechanistic and mechanical effect on initiating fatigue crack growth under high cycle fatigue conditions.
- (4) Develop new three-dimensional computational and analytical modeling tools and detailed parametric analyses to identify the key variables responsible for fretting fatigue damage and failure in engine components, including the identification and optimization of microstructural parameters, geometrical factors and surface modification conditions to promote enhanced resistance to fretting fatigue.
- (5) Develop mechanistic models of the initiation and early growth of small cracks to characterize their role in HCF failure, with specific emphasis on initiation at microstructural damage sites and on subsequent interaction of the crack with characteristic microstructural barriers; and correlate such models to experimental measurement.

Recent Progress

Considerable progress has been made during the fourth year of this research program. Specific accomplishments are outlined below:

❖ *HCF/LCF Interactions.*

The majority of work in this section has been accomplished on Ti-6Al-4V. Unless otherwise noted, the material used was a 6.30Al, 4.17V, 0.19Fe, 0.19O, 0.13N bal. Ti (wt%) alloy supplied as 20-mm thick forged plates after solution treating for 1 hour at 925°C and vacuum annealing for 2 hours at 700°C. This type of material is referred to as Solution Treated Over-Aged (STOA).

- **Effect of frequency:** A comparison of fatigue-crack growth behavior between 50 Hz and 20,000 Hz in ambient air (Fig. 23) indicates no effect of frequency at near-threshold levels. Such frequency-independent growth rates in Ti alloys have also been reported for 0.1–50 Hz. This result is particularly interesting in light of the significant accelerating effect of ambient air on fatigue crack growth when compared to behavior in vacuum. Davidson *et al.* have shown that growth rates *in vacuo* (10^{-6} torr) are ~ 2 orders of magnitude slower than in air at an equivalent ΔK , although the non-propagation threshold remains roughly the same. This apparent discrepancy is most likely an indication that the rate-limiting step of the environmental (air) effect goes to completion in <1 ms.
- **Effect of load ratio:** Constant- R fatigue crack propagation at four load ratios (50 Hz) are compared to constant- K_{\max} data at four K_{\max} values: $K_{\max} = 26.5, 36.5, 46.5,$ and $56.5 \text{ MPa}\sqrt{\text{m}}$ (1000 Hz) in Figure 24. As expected, higher load ratios induce lower ΔK_{th} thresholds and faster growth rates at a given applied ΔK . Based on compliance measurements, no closure was detected above $R = 0.5$; however, at $R = 0.1-0.3$, K_{cl} values were roughly constant at $\sim 2.0 \text{ MPa}\sqrt{\text{m}}$. The measured variation of ΔK_{th} and $K_{\max, \text{th}}$ values versus R are compared in Figures 25a-b, and the variation of ΔK_{th} versus $K_{\max, \text{th}}$ is shown in Figure 25c. The transition apparent in Figures 25a-c is consistent with the observed closure level of $\sim 2 \text{ MPa}\sqrt{\text{m}}$.
- **Worst-case threshold concept:** Fatigue behavior from naturally-initiated small cracks ($\sim 45-1000 \mu\text{m}$) and small cracks ($<500 \mu\text{m}$) emanating from sites of foreign object damage were analyzed. In both cases, crack growth is not observed below $\Delta K \sim 2.9 \text{ MPa}\sqrt{\text{m}}$. The present results show that with constant- K_{\max} cycling at 1 kHz, a “worst-case” threshold can be defined in Ti-6Al-4V by the high R-ratio, long crack threshold of $\Delta K_{\text{TH}} = 1.9 \text{ MPa}\sqrt{\text{m}}$ ($R \sim 0.95$). Consequently, it is believed that the “worst-case” threshold concept can be used as a *practical* lower bound for the stress intensity required for the onset of small-crack growth under HCF conditions, provided crack sizes exceed microstructural dimensions.

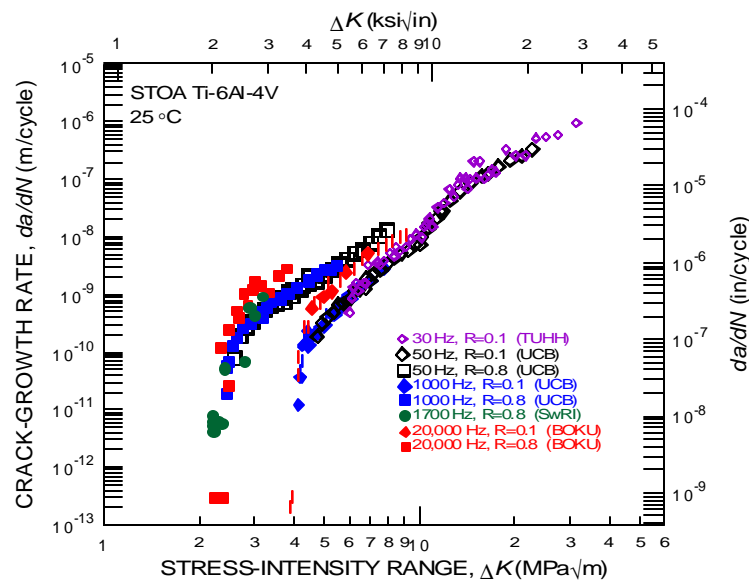

FIGURE 23. Effect of Frequency on Fatigue Crack Growth for Bimodal Ti-6AL-4V in Room Air

- **Effect of mixed-mode loading:** Fatigue-crack growth thresholds for mode-mixity $\Delta K_{\text{II}}/\Delta K_{\text{I}}$ values from 0 (pure mode I) to 7.1 have been measured in the bimodal Ti-6Al-4V blade alloy microstructure at 1000 Hz, and are shown in Figure 27. The measured values of ΔK_{I} and ΔK_{II}

at threshold have been used to construct mixed-mode threshold envelopes for load ratios ranging from $R = 0.1$ to 0.8 . While the mode I threshold, $\Delta K_{I,TH}$, can be reduced with increasing applied phase angle $\beta = \tan^{-1}(\Delta K_{II}/\Delta K_I)$, characterization of the mixed-mode threshold behavior in terms of the limiting strain-energy release rate range, ΔG_{TH} , indicates that the threshold increases monotonically with β , such that the threshold measured in pure mode I represents the worst-case condition. Consequently, for this alloy, the existence of mixed-mode loading should not preclude the use of a threshold-based fatigue-crack growth design methodology. In fact, this strongly suggests that, for continuum-sized cracks, pure mode I thresholds (defined in terms of ΔG) may be used as a conservative estimate of the mixed-mode threshold.

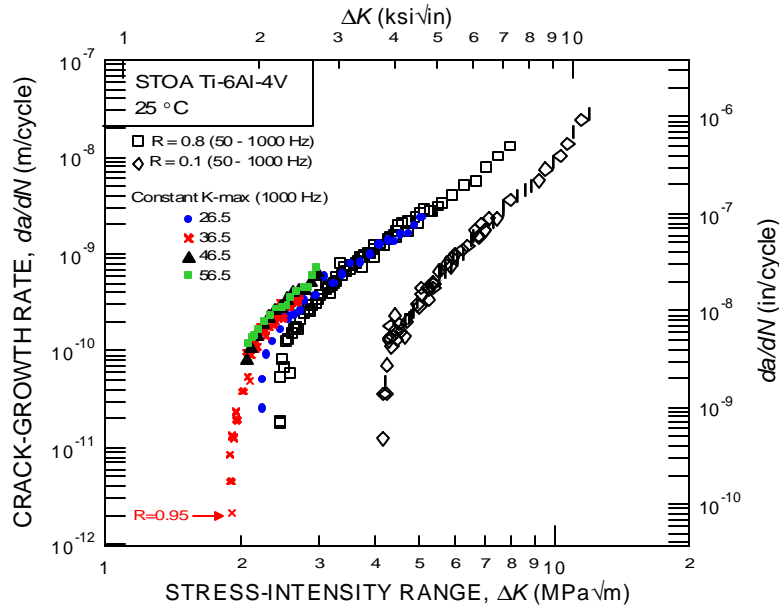

FIGURE 24. Constant- K_{max} Fatigue Crack Propagation Behavior at K_{max} Values of 26.5, 36.5, 46.5, and 56.5 $\text{MPa}\sqrt{\text{m}}$

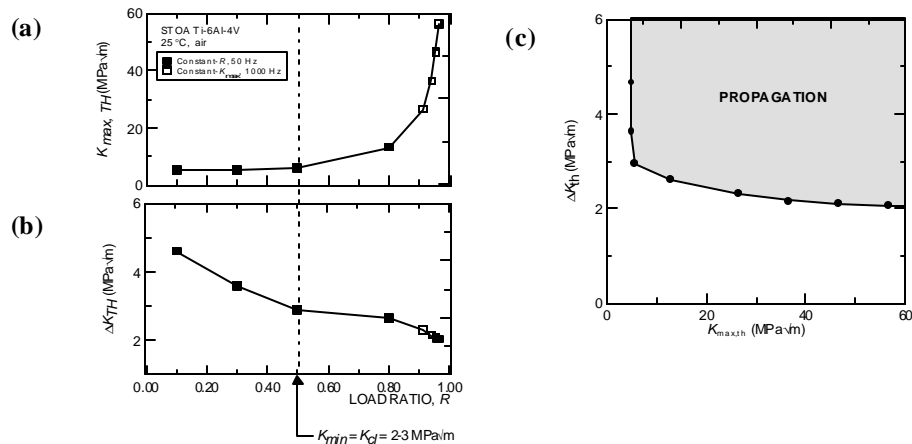

FIGURE 25. Combinations of (a) K_{max} - R , (b) ΔK - R , and (c) ΔK - K_{max} Required for “Threshold” Growth at 10^{-10} m/cycle

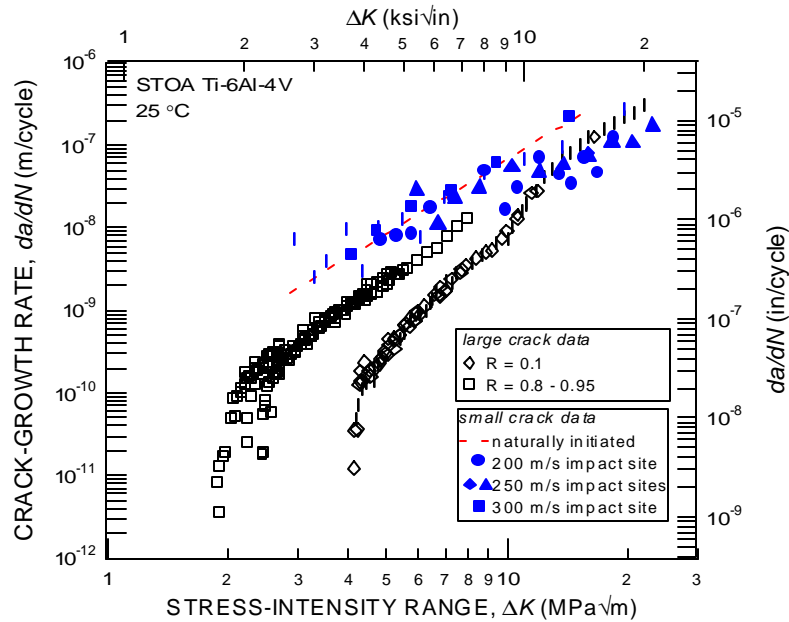

FIGURE 26. Comparison of Worst-Case Large-Crack Propagation Data to Fatigue Growth from Naturally-Initiated Small Cracks and Small Cracks Originating from FOD Sites

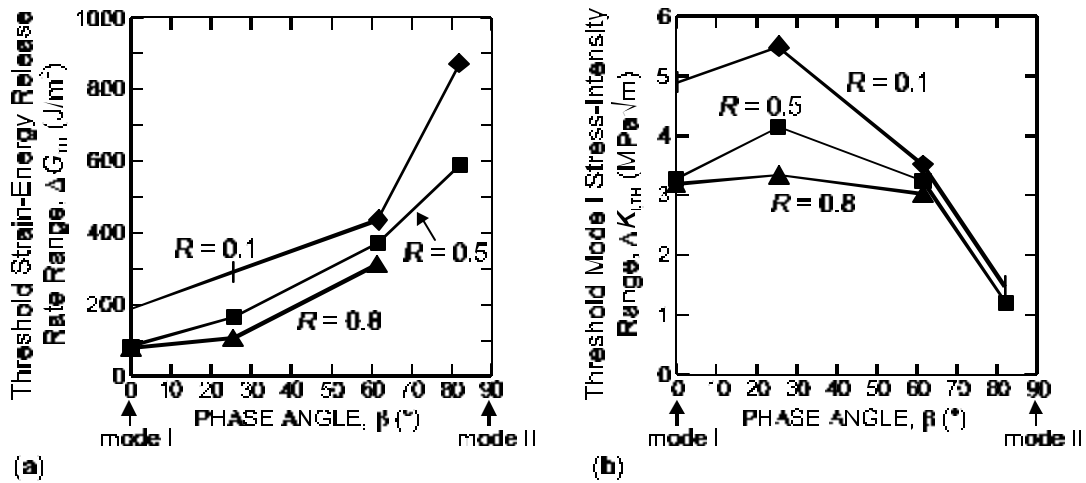

FIGURE 27. Mixed-Mode Fatigue-Crack Growth Thresholds in Bimodal Ti-6Al-4V Plotted in Terms of (a) Strain Energy Release Rate, ΔG_{th} , and (b) Mode I Stress Intensity Range at Threshold, $\Delta K_{i,TH}$

- Large-crack threshold behavior in a polycrystalline nickel-base disk alloy has been characterized at 1,000 Hz at 22° and 550-900°C, with respect to the role of microstructure, frequency, and load ratio. Two different microstructures of KM4 are being studied. By varying the heat treatment, the grain size is varied from around 6 microns (sub-solvus heat treatment) to 60 microns (super-solvus heat treatment). Crack growth rates increased significantly and thresholds decreased as temperature is increased (Fig. 28). An exception to this trend was seen

at 100 Hz, between 550° and 650°C, for the fine-grained material. In this range, the threshold increased by less than 10%. In general, the coarse-grained material had better fatigue crack propagation resistance and higher thresholds than fine-grained material. Crack growth rates increased with load ratio and appeared to be insensitive to frequencies between 50 and 1,000 Hz. However, initial results indicate that crack threshold values are a complex function of microstructure and test frequency, as shown in Table 1.

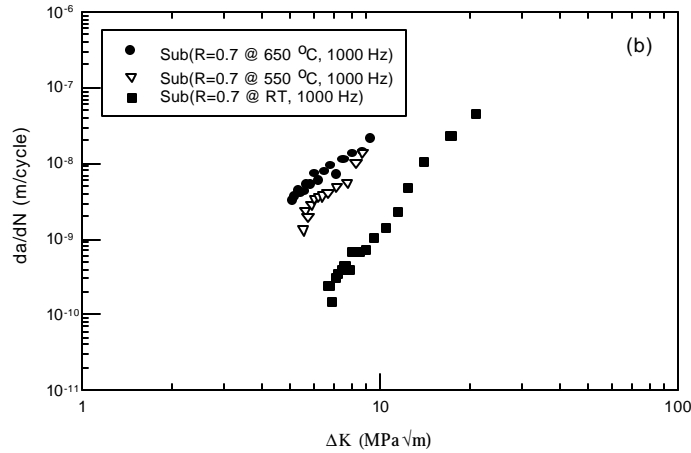

FIGURE 28. Fatigue-Crack Propagation Curves for Fine-Grained KM4 at 25°, 550° and 650°C

Temperature	Fine grain material				Coarse grain material			
	100 Hz		1000 Hz		100 Hz		1000 Hz	
	R=0.4	R=0.7	R=0.4	R=0.7	R=0.4	R=0.7	R=0.4	R=0.7
25°C	-	-	8.4	6.8	-	-	10.3	9.9
550°C	5.1	4.4	5.9	5.0	6.15	5.6	6.15	5.35
650°C	5.2	4.65	4.25	3.9	4.55	4.0	5.6	4.6

TABLE 1. ΔK_{th} Values Under the Selected Experimental Conditions. All Values in $MPa\sqrt{m}$.

❖ *Notches and Foreign Object Damage.*

➤ Using high-velocity (200-300 m/s) impact of 3.2 mm steel spheres on the flat surface of fatigue test specimens to simulate FOD, it was found that the resistance to HCF is markedly reduced due to accelerated crack initiation. Premature crack initiation and subsequent near-threshold crack growth were primarily affected by the stress concentration associated with the

FOD indentation and by the presence of small microcracks in the damaged zone (seen only at the higher impact velocities). It is shown in Figure 29 that FOD-initiated cracks that are of a size comparable with microstructural dimensions can propagate at applied stress-intensity ranges on the order of $\Delta K \sim 1 \text{ MPa}\sqrt{\text{m}}$, approximately half of the “worst-case” threshold stress-intensity range in Ti-6Al-4V for a microstructurally large crack. The threshold against crack growth from FOD-induced microstructurally-small cracks can be defined, in terms of *stress concentration corrected* stress ranges, from the “El Haddad” line in the Kitagawa-Takahashi diagram (Fig. 30). The limiting conditions are described in terms of the 10^7 -cycle (smooth-bar) fatigue limit (at microstructurally-small crack sizes) and the worst-case large-crack fatigue threshold (at larger, “continuum-sized” crack sizes).

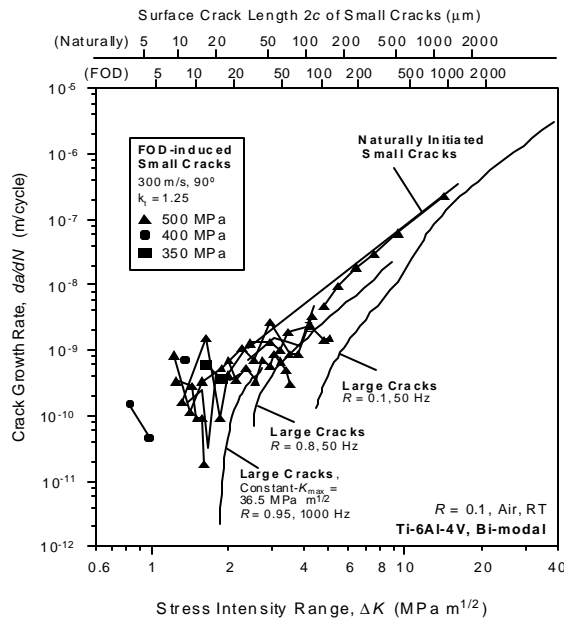

FIGURE 29. Crack-Growth Rates as a Function of Applied Stress-Intensity Range of FOD- and Naturally-Initiated Small Cracks and Through-Thickness Large Cracks

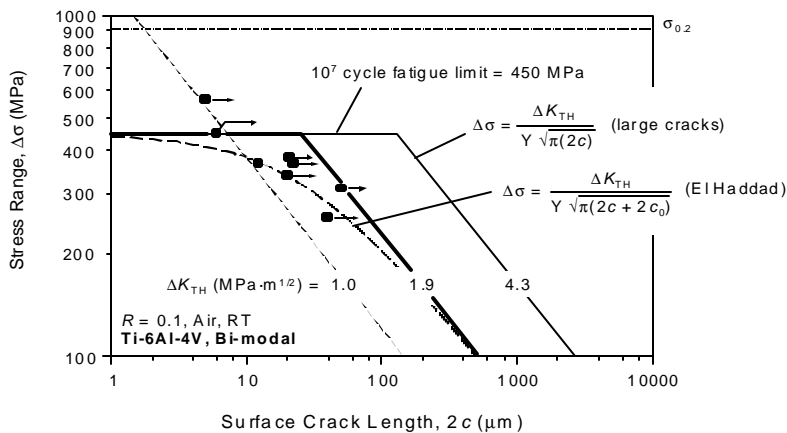

FIGURE 30. Modified Kitigawa-Takahashi Diagram Representing the Threshold Crack-Growth Conditions for FOD-Induced Small Cracks in Ti-6Al-4V

- Efforts to measure the residual strain field around FOD damage sites have continued. Surface-normal residual strain fields have been determined experimentally by symmetric powder diffraction and numerically by the finite element method (FEM). There is good agreement between these two results for moderate-velocity (200 m/s) impacts. However, there is a notable discrepancy between the FEM results and x-ray measurements for high-velocity (300 m/s) impacts. In the high-velocity case, FEM results predict a more intense residual strain field (Fig. 31). A portion of the discrepancy is attributed to the quasi-static nature of the FEM analysis.

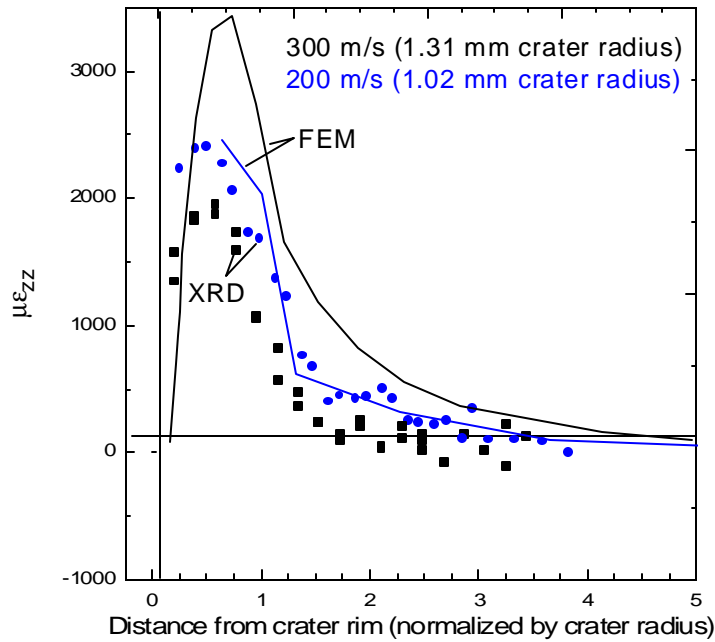

FIGURE 31. Survey of Residual Strain Gradient Emanating Away from the Crater Rim at the Surface of the Specimen

- Experimental measurements have highlighted the high degree of point-to-point variability in the residual strain field. A fully annealed sample with no macroscopic residual stresses can exhibit $\sim 500 \mu\epsilon$ (~ 50 MPa equivalent uniaxial stress) of variability depending on the location of the spot (based on an interrogated spot size of $500 \mu\text{m} \times 500 \mu\text{m}$). The most likely source of this variability is associated with the local residual stresses locked in during the formation and cool-down of the anisotropic microstructure. An example of a crater survey (Fig. 32) shows the high degree of variability, causing local “hot spots” of strain (red peaks).

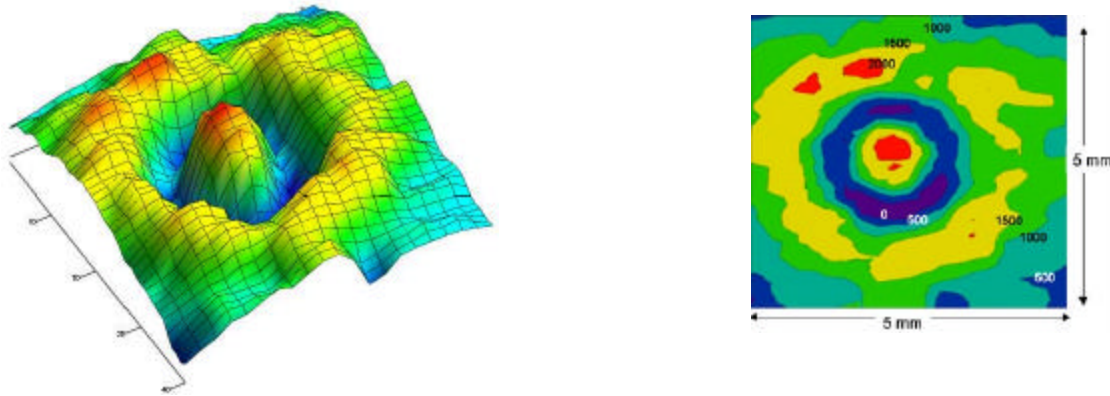

FIGURE 32. Results from a 2-Dimensional Strain Survey Around a 200 m/s Impact Site. Isostrain Contour Values on Right in Units of $\mu\epsilon$

❖ **Fretting Fatigue:**

- *“Notch Analogue” model for fretting fatigue:* The effect of roundness of a nominally sharp contact geometry on fretting fatigue crack initiation has been investigated. Using analytical and numerical finite element methods, the asymptotic forms for the stress fields in the vicinity of a rounded punch-on-flat substrate were derived for both normal and tangential contact loading conditions. By examining the similarities between the asymptotic stress fields for the sharply-rounded flat punch contact and those around the tip of a blunt crack, a “notch analogue” model for fretting fatigue crack initiation was developed. The analysis showed that the maximum tensile stress that occurs at the edge of the contact is proportional to the mode II stress intensity factor of a sharp punch weighted by a geometric factor related to the roundness of the punch. Conditions for crack initiation were then derived through a comparison of the maximum tensile stress at the edge of the fretting contact and the plain fatigue endurance limit of the material.
- *Fretting fatigue experiments:* A systematic investigation of the fretting fatigue behavior of the Ti-6Al-4V alloy in both the mill annealed and bimodal microstructure was carried out using a sphere-on-flat fretting fatigue device. This device facilitated real-time control and monitoring of all the relevant parameters such as the contact geometry, contact (normal and tangential) loads, and the bulk alternating stress. While three sets of experiments were conducted to examine the influence of the bulk stress, the tangential load, and the normal load, respectively, on fretting fatigue response, the effect of microstructure on fretting fatigue was explored briefly with experiments on the acicular, Widmanstätten, and martensitic Ti-6Al-4V as well. Important results from this study were:
 - (a) In the experiments where the contact loads were maintained constant while the bulk stress was varied, fretting reduced the fatigue strength of Ti-6Al-4V, with the strength reduction factor being higher for those experiments with a constant but higher tangential load compared to those with a constant but lower tangential load (Fig. 33);
 - (b) For cases where the bulk stress and the normal loads were maintained constant, the total life to failure of the fretted materials was reduced as the tangential load increased, the reduction in life being larger for the experiments with the lower fretting pad radius (Fig. 34);

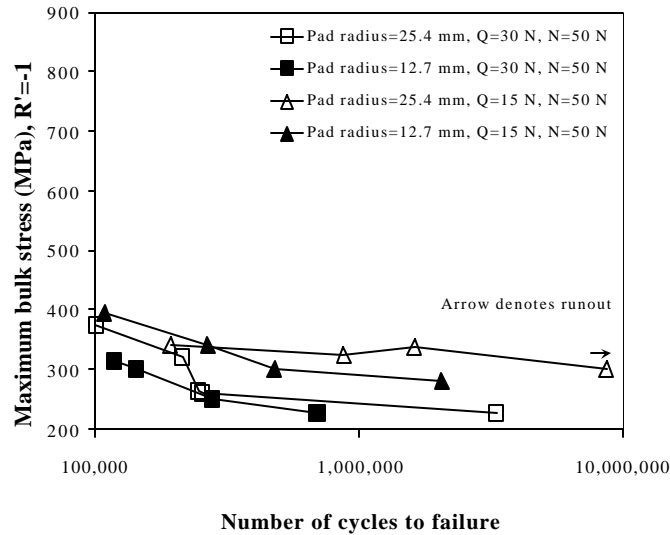

FIGURE 33. Fretting Fatigue Results from Experiments on Mill Annealed Ti-6Al-4V Illustrating Variation of Total Life with Changes in the Bulk Stress Applied to the Specimen

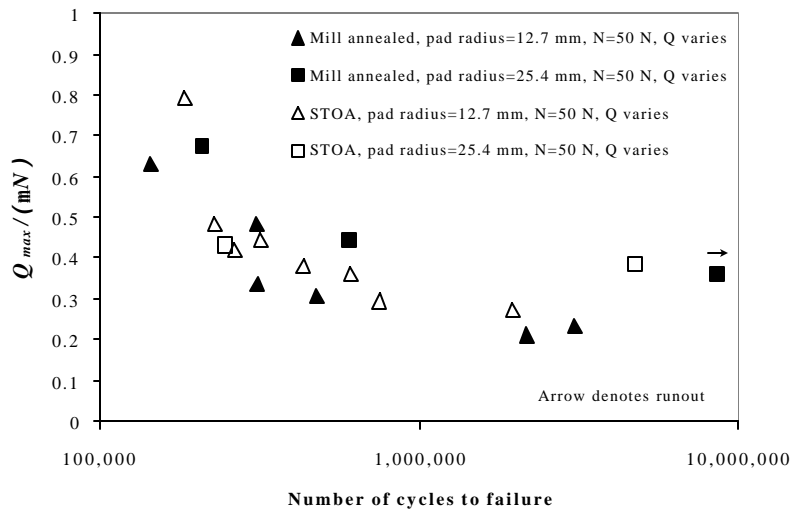

FIGURE 34. Fretting Fatigue Results from Experiments on Mill Annealed and STOA Ti-6Al-4V Illustrating Variation of Total Life with Changes in the Tangential Loads Applied to Fretting Contact. ($\sigma_b = 300$ MPa, $\mu = 0.95$)

- (c) In the experiments where the bulk stress and the tangential loads were maintained constant, the total life to failure of the fretted materials increased as the normal load increased, the increase in life being larger for the experiments with the larger fretting pad radius (Fig. 35);
- (d) With the exception of the martensitic structure, which displayed enhanced fretting fatigue resistance, the other microstructures did not exhibit a significant improvement in fretting fatigue resistance compared to the basic STOA or the mill annealed microstructure;

- (e) Using the measured maximum static friction coefficient of 0.95 for Ti-6Al-4V, the experimentally observed contact and stick-zone radii exhibited good agreement with analytical predictions;
- (f) The adhesion model predictions concerning strength of adhesion (weak) and crack initiation were validated with experimental observations of stick-slip behavior and fretting fatigue failures, respectively.

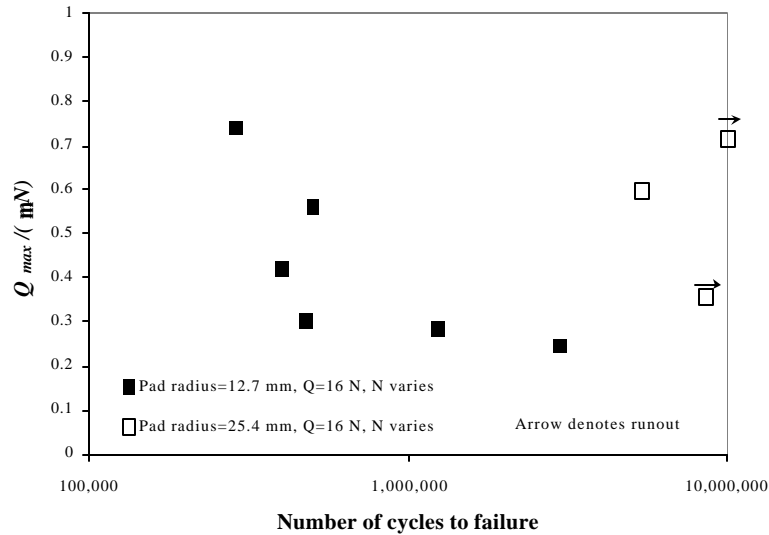

FIGURE 35. Fretting Fatigue Results from Experiments on Mill Annealed and STOA Ti-6Al-4V Illustrating Variation of Total Life with Changes in the Normal Loads Applied to Fretting Contact ($\sigma_b = 300$ MPa, $\mu = 0.95$)

Participating Organizations: Air Force Office of Scientific Research (AFOSR), University of California at Berkeley, Massachusetts Institute of Technology, Michigan Technological University, Harvard University, Southwest Research Institute, Imperial College, London University, Technische Universität Hamburg-Harburg, Universität für Bodenkultur (BOKU)

Points of Contact:

Government

Dr. Craig Hartley
 U.S. Air Force, AFOSR/NA
 801 North Randolph Street, Mail Room 732
 Arlington VA, 22203-1977
 Phone: (202) 767-8523
 Fax: (202) 767-8451
 Email: craig.hartley@afosr.af.mil

Contractor

Prof. Robert O. Ritchie, Ph.D., Sc.D.
 University of California at Berkeley
 Dept. of Materials Science and Mineral Engineering
 Berkeley, CA 94720-1760
 Phone: (510) 486-5798
 Fax: (510) 486-4995
 Email: roritche@lbl.gov

2.4 Improved HCF Life Prediction (Fan)

FY 96-00

Background

The focus of this program was the development of damage-tolerant design processes for gas turbine engines that substantially reduce the potential occurrence of high cycle fatigue failures in titanium (fan) structures. Specific objectives for this program were: (1) characterization of in-service damage associated with high-cycle fatigue loading of titanium fan blades; (2) development of techniques to generate damage states in the laboratory that are representative of in-service damage; (3) modeling of the nucleation and progression of damage in titanium fan blades; and (4) development of an improved damage-tolerant life prediction and design methodology for turbine engine rotating structures subjected to HCF and combined HCF/LCF loadings.

This program was accomplished through the development of a better understanding of the three primary damage mechanisms experienced in the fan section, and through the transitioning of that understanding into the development of improved damage tolerance life prediction methodologies. All experimental studies were performed on an $\alpha+\beta$ processed Ti-6Al-4V forged plate, specifically produced to provide a representative titanium alloy with consistent properties.

Final Results

Specifically, this program was performed through the accomplishment of research in the following areas:

- ❖ *HCF/LCF Interactions* research was aimed at developing a better understanding of the fatigue and crack growth damage accumulation processes due to the load interactions generated in HCF/LCF loading. This included the study of fatigue crack threshold behavior for both pristine and LCF-damaged material (with various surface treatments), as well as the development of baseline material data for comparison with other damage modes. Specific accomplishments in this area include:
 - High-resolution studies of HCF/LCF crack growth with the SwRI DISMAP system found no significant, systematic effect of periodic LCF unloads on near-threshold fatigue crack growth rates under high-R HCF cycling. This result is consistent with detailed crack-tip micromechanics analyses conducted under another program, which found no significant changes in crack-tip strains or crack closure with the periodic LCF unloads.
 - The fatigue crack growth behavior of microstructurally short cracks, which have been known to propagate below conventional long-crack ΔK_{th} values, was evaluated. Naturally-initiated fatigue cracks in smooth specimens (tested at $\Delta\sigma = 80$ ksi, $R = 0.1$, and frequency 60 Hz) were documented via surface replication performed at uniform intervals of 15,000 cycles.

According to the general trend observed in Figure 36, an initially high crack propagation rate abruptly decreases, reaches certain minimum value, and then gradually increases. This is accompanied by substantial reduction in experimentally observed scatter in crack propagation rate as the crack grows. In Figure 36a, crack size corresponding to the minimum crack propagation rate is also compared to the average primary-alpha grain size. The major trend in crack propagation behavior changes from deceleration to acceleration after the crack tip passes through the first or second primary-alpha grain boundary. At the same time, in one case (specimen 2) an additional crack growth retardation event occurred when the crack size (depth

or surface half-length) was five times larger than the average primary-alpha grain. Based on the data presented in Figure 36a, fatigue crack propagation behavior in the present material was divided into two separate regimes with respect to microstructural sensitivity.

Similar trends in fatigue crack propagation behavior can be seen in Figure 36b. In this graph, the results obtained are plotted as a function of stress intensity factor range, ΔK , and compared to the crack propagation behavior of “long” cracks in both compact tension and surface flow type specimens. It can be seen that naturally-initiated “small” cracks propagate well below the “long” crack threshold, and that naturally-initiated “small” cracks propagate much faster than “long” cracks for stress intensity range values slightly greater than the “long” crack threshold. The tendency for faster propagation persists up to $\Delta K \sim 10$, at which point both sets of data merge together.

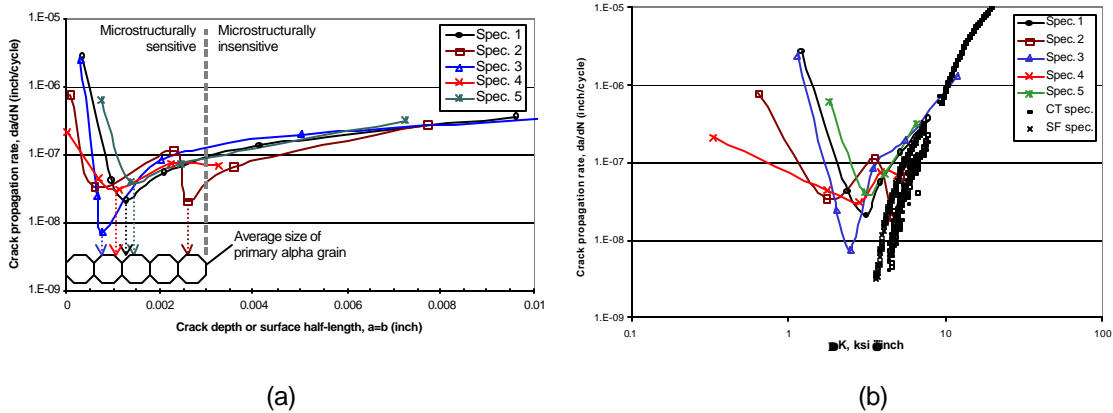

FIGURE 36. Fatigue Crack Propagation Rate of Naturally-Initiated “Small” Cracks as a Function of: (a) Crack Size and (b) Stress Intensity Factor Range

❖ *Foreign Object Damage* research was aimed at developing a better understanding of the occurrence and levels of FOD in different sections of turbine engines and characterizing the relevant parameters for modeling FOD damage progression. Techniques for reproducing damage representative of in-service FOD were investigated, and specimens containing laboratory-induced FOD were tested to characterize the effects of FOD. Specific accomplishments in this area include:

- Test results indicate that the presence of a large stressed area (unnotched FOD specimen) results in a predicted life similar to those of smooth specimens with a similarly highly stressed area. Yet, a relatively small notch (notched FOD specimens) can apparently result in increased capability prior to failure if the small area of highly stressed material is not accounted for in the analysis. The Socie stress model seems to correlate the notched data quite well, suggesting that the shear cracking mode might be dominant in the notched specimens. However, use of the Socie stress parameter along with the notch stress state (after accounting for notch-cyclic plasticity) does not adequately correlate with the smooth-data curve-fit. Correlation of smooth and notched data will continue under effort 2.5.
- FOD testing was performed on airfoil-shaped tension specimens and winged specimens. Three methods were used to simulate FOD in the winged specimens: machined notches with a 0.021-inch radius, ballistic ball impacts with 0.020 and 0.039-inch radius glass beads, and solenoid gun impacts with a chisel-point indenter (0.005 and 0.025-inch radii tips). Specimens were machined or impacted to simulate FOD nicks at 0° and 30° relative to the centerline of the

leading edge region on the specimen. Low damage and high damage target levels were set at depths of 0.005 and 0.020-inch. Figure 37 compares 30° notches in sharp-leading-edge specimens with ballistic and solenoid gun impacts. Actual notch depths ranged from 0.003 to 0.009 inches and from 0.015 to 0.026 inches.

Ballistic Impact with
0.020 Inch Radius Ball

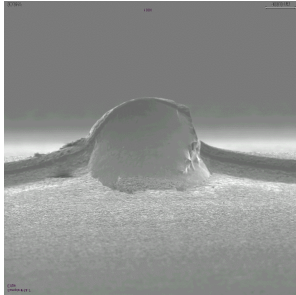

Solenoid Gun with 0.025
Inch Radius Indentor

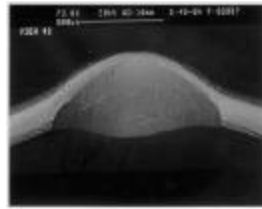

Solenoid Gun with 0.005
Inch Radius Indentor

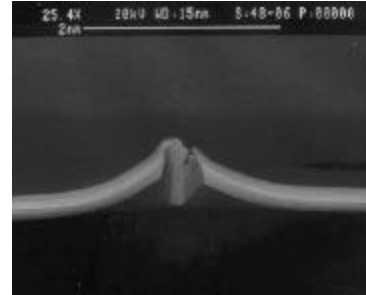

FIGURE 37. Representative FOD from Ballistic and Solenoid Gun Impacts (Sharp Leading Edge Specimens, 30° Impacts, High Damage Levels)

Results from endurance limit testing (10^6 cycles) indicate that the ballistic impact results are not significantly different from the solenoid gun results at equivalent damage depths and impactor radii. The solenoid gun has since been adopted as the simulated FOD impactor of choice for its repeatability.

Several un-impacted and impacted specimens were tested under axial-load-control HCF conditions for comparison to baseline smooth bar fatigue data. The data clearly indicate good agreement with the smooth-bar baseline for non-impacted tests, and the negative effect that FOD has on HCF life, as shown in Figure 38. The non-recoverable energy showed poor correlation between the energy recorded and the subsequent HCF life of impacted specimens. Fractography showed that some of the initiation sites were significantly (e.g., 0.004 inches) below the surface of the FOD impact. From the microstructural deformation observed below the FOD impact, it appears that significant cold work stresses should exist. However, these residual stresses were not measured.

- ❖ *Fretting Fatigue* research was aimed at developing a better understanding of the occurrence and levels of fretting fatigue damage at the fan blade root / disk hub interface. Techniques for reproducing damage representative of in-service fretting fatigue were investigated, and specimens containing laboratory-induced fretting and fretting fatigue damage were tested to characterize the effects of fretting fatigue on the HCF behavior.

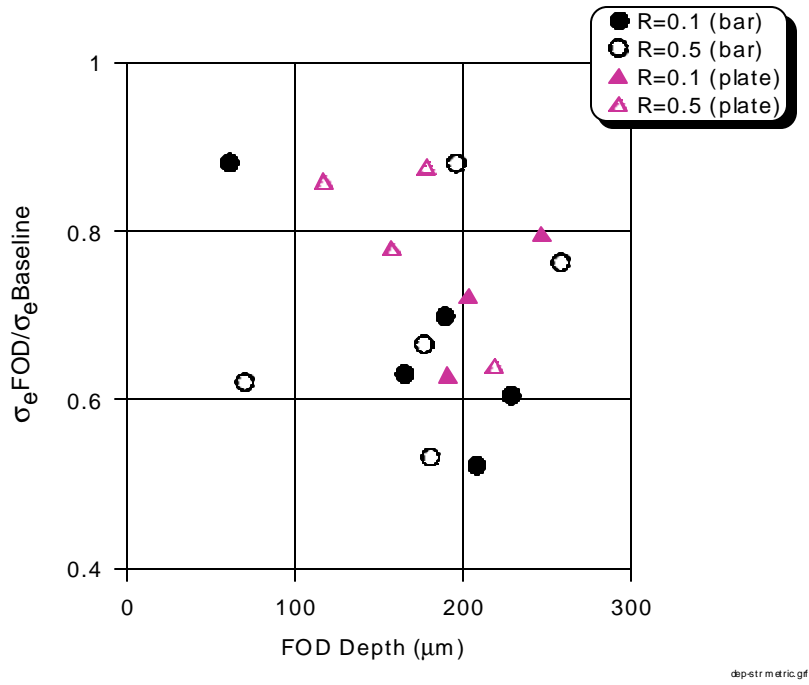

FIGURE 38. Normalized Fatigue Endurance Strength as a Function of FOD Depth

- Multiaxial fatigue tests were performed on solid-round specimens for Ti-6Al-4V for the purpose of evaluating several different total life methodologies. The stress invariant model that best predicted the experimental results is based on the effective stress range and a modified Manson-McKnight mean stress. Three different critical plane models, the Smith-Watson-Topper (SWT), the Fatemi and Socie (FS), and the Socie models were also evaluated. The SWT model was found to correlate the data with various stress-ratios quite well. The Socie effective stress parameter was able to collapse all of the data for the different R-conditions reasonably well in both the LCF and HCF regimes. The good correlation of the HCF data using the Socie model also suggests that a shear-cracking mode might be dominant in the HCF regime in general. The FS strain did not correlate the data as well as the Socie stress parameter.
- Friction experiments were conducted by Purdue University to study the evolution of the coefficient of friction, μ , with the number of cycles in partial slip experiments in bare Ti-6-4 on Ti-6-4. The pads used were cylindrical, resulting in Hertzian distribution in the contact zone. Loading was stopped after running for a specified number of cycles. Then, without disturbing the pad/specimen contact, a waveform of increasing amplitude was applied to the specimen. The experiment was then stopped when the pad just started sliding (about 50 cycles). The average coefficient of friction was then calculated using the maximum value of the tangential force before the pad started sliding. The friction experiments were conducted with two different sets of pads of radii 5 inches and 7 inches. The maximum bulk stress applied during the experiments was 42 ksi. Figure 39 shows the results of the friction experiments. These results are similar to the results of fretting tests with flat pads performed at General Electric Aircraft Engines (GEAE).

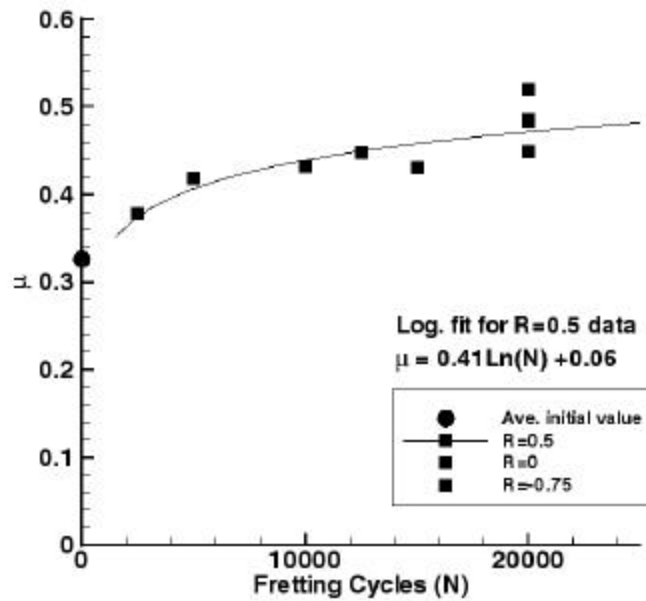

FIGURE 39. Evolution of Coefficient of Friction

An investigation utilizing both integral equation and finite element methods was performed to determine edge-of-contact stresses. Stress analyses were performed for a relatively simple two-dimensional problem. A finite element mesh size of 0.0625 mil was required to obtain a fully converged solution. The integral equation method did not require a mesh and resulted in significantly shorter time-to-solution. For the two-dimensional experiments in the current program, the singular integral equations give a solution that matches very well with the solution obtained from the finite element analysis as shown in Figure 40.

Pressure and Shear under a Mindlin Loading Scheme

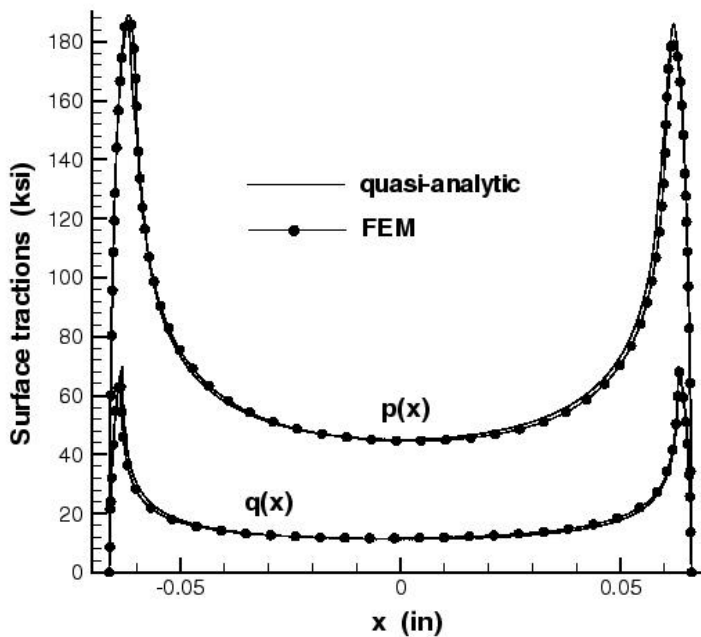

FIGURE 40. Comparison of Surface Normal Tractions Obtained from Integral Equation and FEM Methods

❖ *Damage-tolerant Life Prediction Methodologies:* Damage-tolerant life prediction methodologies have been developed or utilized as mentioned in the three damage state areas above. In each of the three areas, exit criteria have been developed to ascertain the level of accuracy of the techniques for determining the HCF alternating load capability of damaged materials. The metric for assessing the predictive accuracy is based on the ratio of “actual to predicted” capability where actual capability is determined in bench testing. For the different damage states, exit criteria are based on different limits put on the mean and coefficient of variation (COV) of the “actual-to-predicted” capability, as compared to that for baseline smooth axial fatigue specimens. The exit criteria are listed in Table 2. Validation and continued development of damage-tolerant life prediction methodologies will take place in the effort described in section 2.5, “Advanced HCF Life Assurance Methodologies.”

<u>Damage State</u>	<u>Mean Ratio*</u>	<u>COV*</u>
LCF/HCF Interaction	0.95 – 1.05	1.25 X
Foreign Object Damage	0.85 – 1.15	2.50 X
Fretting Fatigue	0.85 – 1.15	2.50 X

** as compared to baseline smooth axial fatigue specimens*

TABLE 2. Materials Damage Tolerance Damage State Exit Criteria

Participating Organizations: University of Dayton Research Institute, General Electric Aircraft Engines, Pratt & Whitney, Rolls Royce Allison, Honeywell Engines and Systems, Southwest Research Institute, Purdue University, North Dakota State University, University of Illinois

Points of Contact:

Government

Dr. Theodore Nicholas
 U.S. Air Force
 AFRL/MLLMN, Bldg. 655
 2230 Tenth St., Suite 1
 WPAFB, OH 45433-7817
 Phone: (937) 255-1347
 Fax: (937) 656-4840
 Email: theodore.nicholas@afri.af.mil

Government

Dr. Jeffrey Calcaterra
 U.S. Air Force
 AFRL/MLLMN, Bldg. 655
 2230 Tenth St., Suite 1
 WPAFB, OH 45433-7817
 Phone: (937) 255-1360
 Fax: (937) 656-4840
 Email: jeffrey.calcaterra@afri.af.mil

Contractor

Dr. Joseph P. Gallagher
 Univ. of Dayton Research Institute
 300 College Park
 Dayton, OH 45469
 Phone: (937) 229-2349
 Fax: (937) 229-3712
 Email: gallagher@udri.udayton.edu

2.5 Advanced HCF Life Assurance Methodologies (Fan & Turbine)

FY 99-02

Background

This program is a follow-on to Effort 2.4, “Improved HCF Life Prediction,” and is focused on the extension and validation of the technologies developed in the earlier effort to other titanium alloys for use in the fan section, as well as to single crystal nickel-base superalloys for use in the turbine section. The objectives of this program are: (1) to extend the understanding of damage mechanisms in $\alpha+\beta$ processed Ti-6Al-4V blades and disks to other titanium alloys with varying microstructures, (2) to develop a better understanding of the underlying damage mechanisms to which single crystal nickel-base superalloy blades and disks are subjected, and (3) to extend and validate the damage-tolerant life prediction and design methodologies developed for $\alpha+\beta$ processed Ti-6Al-4V to other titanium alloys and to single crystal nickel-base superalloys.

Recent Progress

Similar to “Improved HCF Life Prediction,” this program is being accomplished through the development of a better understanding of fretting, FOD and HCF/LCF interaction. This includes damage mechanisms of importance to the turbine as well as the fan. All experimental studies to date have been performed on the same $\alpha+\beta$ processed Ti-6Al-4V forged plate as discussed previously in this report.

❖ *HCF/LCF Interactions:*

- A program has recently been initiated to characterize the HCF/LCF behavior of Ti-6Al-4V under typical engine conditions. Mission profiles are being used to determine the accurate stress state in the laboratory specimens. Initial results show negligible influence of small amounts of LCF on material HCF properties (Fig. 41). Several critical-plane and stress-invariant life prediction parameters will be assessed for their ability to accurately predict material life.

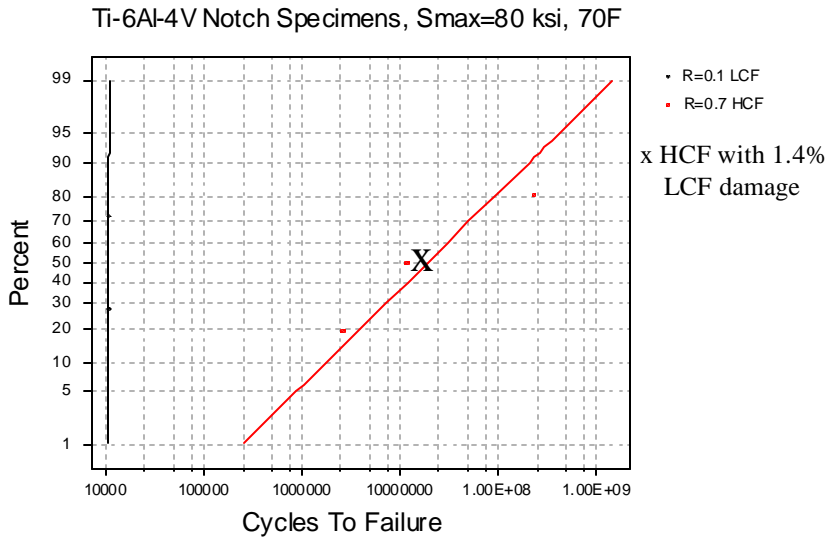

FIGURE 41. Influence of 1.4% LCF Damage on HCF Properties of Ti-6Al-4V

- The HCF/LCF characteristics of Ti-6Al-4V are being compared to a beta processed titanium, Ti-17 β , and a single crystal nickel alloy, PWA 1484. For both materials, most specimens have been machined and test matrices have been defined. The LCF properties of Ti-17b have also been established. The half-life properties of Ti-17b are shown in Figure 42.

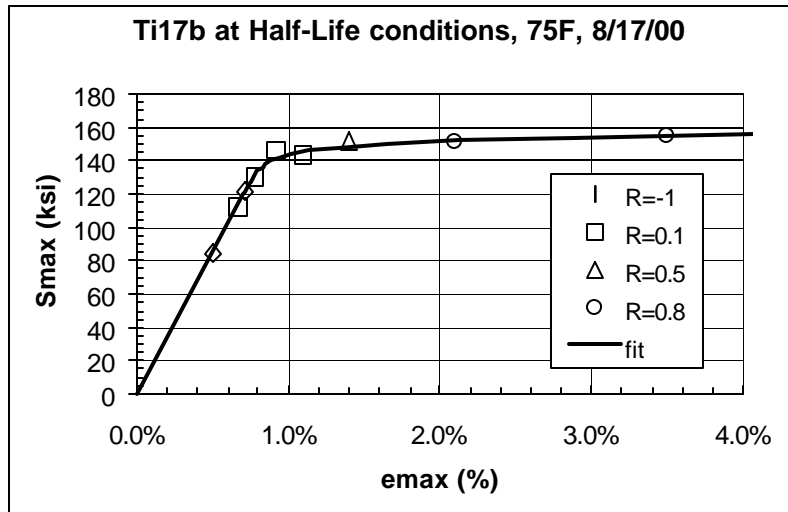

FIGURE 42. Half-Life properties of Ti-17 β

Baseline ΔK_{th} testing is currently being performed on Ti-17 β . Once these tests are completed, mission analysis of Ti-17 β will begin.

- Work on PWA 1484 has been initiated. All testing done on this material will be conducted at 1100° or 1900°F. To date, testing has focused on determining frequency effects, constitutive properties, and applicable shed rates for crack growth testing. Frequency studies have been conducted at 200 and 900 Hz. PWA 1484 shows significant time dependence at these frequencies, even at R = -1. Stouffer and Walker constitutive models are being developed to

capture the high temperature, rate, and orientation dependencies present in this material. A complex strain test profile has been developed to capture history effects, and while the bulk of the work in constitutive model development has gone to identifying shortcomings of current methods, several tests have been completed. Both constitutive models are necessary to identify the usefulness of critical plane life prediction approaches. Finally, shed rates as high as 20 in^{-1} have been demonstrated in this material without affecting threshold values. A shed rate this high will allow for relatively short test times when determining threshold crack growth values.

❖ *Fretting Fatigue:*

- The primary emphasis in fretting fatigue is on the implementation of successes achieved under the programs listed above and the extension of the work to PWA 1484. Industry is currently incorporating the integral equation method described in the previous section into their design processes. Currently, a hybrid FEM/integral equation method is being developed to account for three-dimensional structures. The current approach calls for an initial, coarse finite element analysis, which allows for the determination of average stresses throughout the contact region. This eliminates the need for refined meshes that are computationally intensive. The average stresses are then used by the integral equation method to determine their distribution across several two-dimensional “slices” of the structure. The hybrid method has already been applied to seven different engine lines and has significantly reduced time-to-solution. One example of the timesaving afforded by this method is a sensitivity study that was recently completed. Using conventional finite element methods, this study was estimated to take several months. However, the hybrid method completed the study in one day.
- Previous methods for stress analysis in engine attachment regions provided designers contact stresses of limited fidelity. Since the errors caused by limited fidelity stresses could greatly affect the output of any lifing methodology, highly accurate life prediction methods have not been developed for contact fatigue. Due to the implementation of the integral equation method, designers now have much more accurate stress data for engine attachment regions. Because of this, the program is now focusing on the development of life prediction methods for contact regions. An approach has been used that correlates the stress and strain response ($\Gamma = \sigma_{\max} \Delta \epsilon / 2$), averaged to an experimentally determined depth below the contact region, to smooth bar fatigue life. This approach provides conservative results (Fig. 43), in the limited results analyzed to date.
- In addition to the Γ parameter, several other life prediction methodologies are being evaluated. These include the critical plan and stress invariant approaches discussed in the previous section, as well as an elastic-plastic shakedown model being developed specifically for this program. The shakedown model accounts for the redistribution of stresses due to plastic deformation and has been shown to reduce overconservatism in design. The shakedown model is being developed for both isotropic and anisotropic alloys.
- Fretting in single crystal alloys is a difficult problem because of the extremely high temperatures involved in material testing. Currently, a high-temperature fretting rig (Fig. 44) is being accredited for these materials. This rig has been tested to a temperature of $1,110^{\circ}\text{F}$ and has been shown to be stable within $\pm 7^{\circ}\text{F}$. Once the rig is accredited, testing on single crystal alloys will commence.

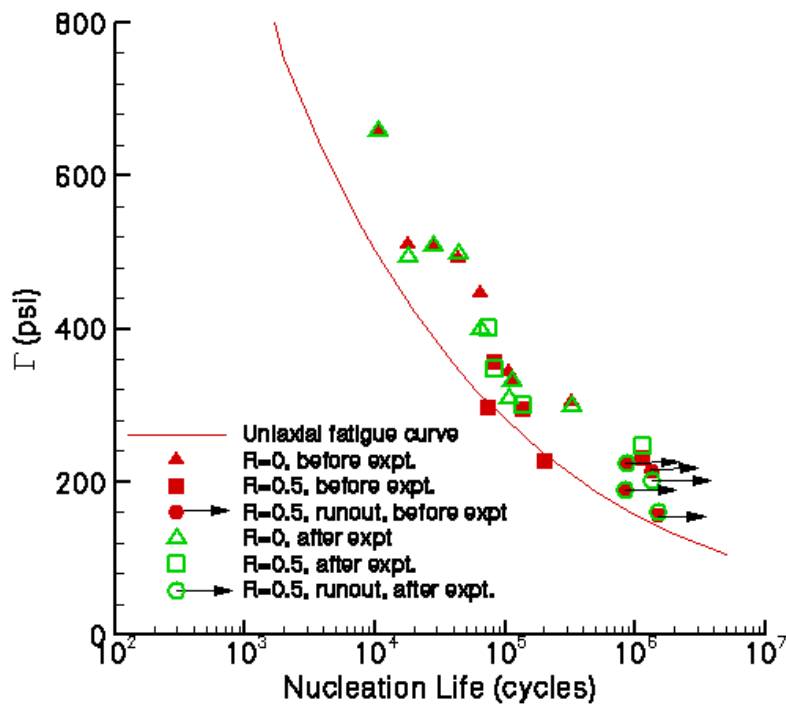

FIGURE 43. Correlation of Fretting Γ Parameter to Uniaxial Fatigue Curve

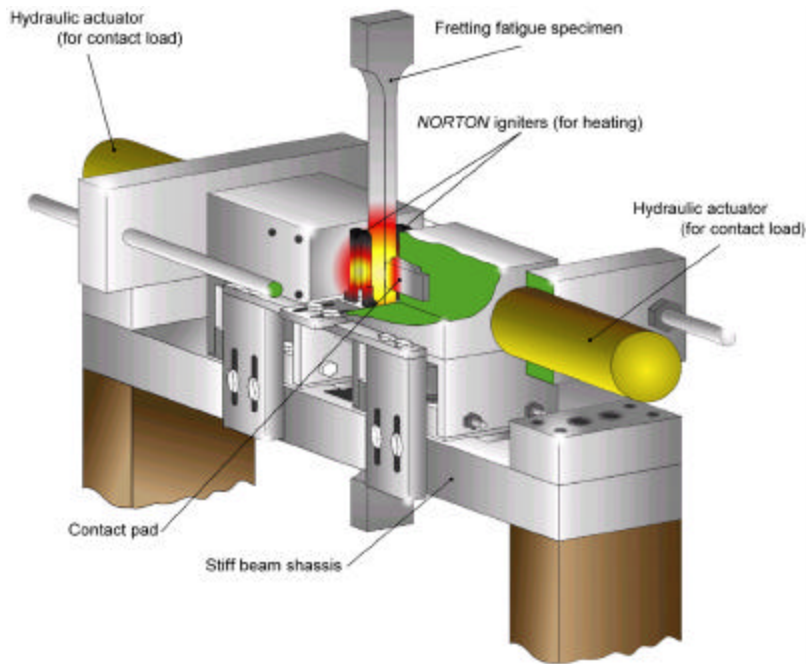

FIGURE 44. High-Temperature Fretting Fatigue Rig

❖ *Foreign Object Damage:*

- Like fretting, the current FOD research program is focused on the implementation and validation of previously developed life prediction methodologies. A stressed area approach,

similar to the Γ parameter described in the previous section, has been implemented by industry. This approach differs slightly in that it does not take the stress state at a given depth. Instead, an equivalent flaw size is used to determine the depth of the stress state. This approach shows significant life prediction improvement over the current design criteria of using a 3 mil depth (Fig. 45).

- A fracture-mechanics-based life prediction methodology for FOD damage on engine airfoils is currently being implemented in engine design. The method uses stress data from analytical blade studies performed and validated under the current program. The highly accurate prediction of blade stresses, in conjunction with the improved life prediction methodology, has resulted in an accurate estimation of HCF endurance stresses for a wide range of notch depths (Fig. 46). This process reduces the uncertainty in the design process and has the potential to increase nick and blend limits in both existing and future engine airfoils, thereby reducing the number of scrapped parts. The process is currently waiting spin pit or compressor rig validation before it is formally included into industry design procedures.

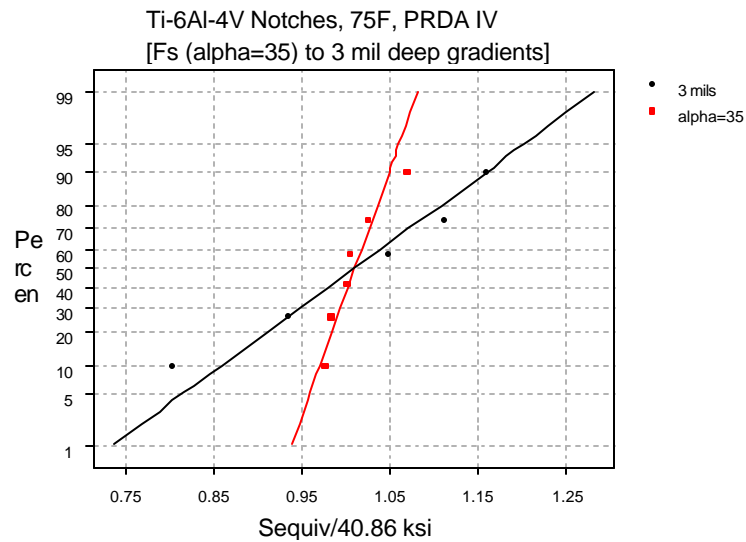

FIGURE 45. Improvement of Equivalent Flaw Size Parameter over Current Design Procedures

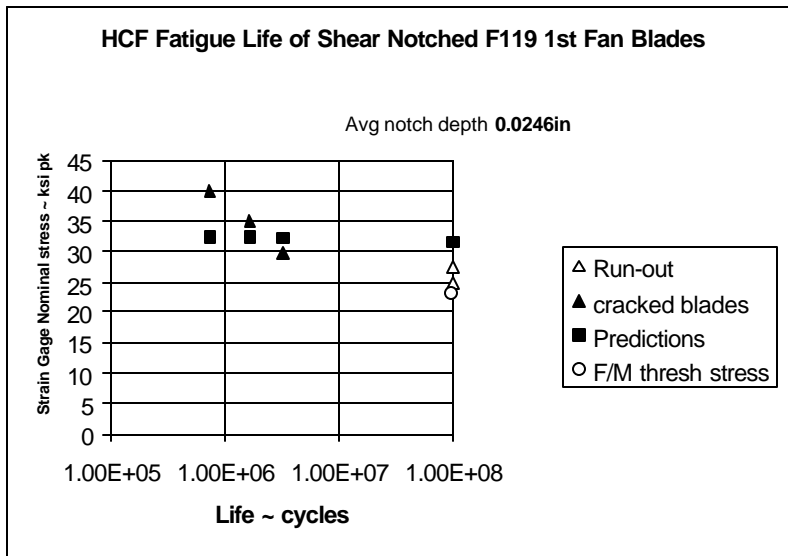

FIGURE 46. Comparison of Fracture Mechanics Based Threshold Stress and Life Predictions from Existing Design Methods

Participating Organizations: Air Force Research Laboratory (AFRL), Air Force Office of Scientific Research (AFOSR), University of Dayton Research Institute, General Electric Aircraft Engines, Pratt & Whitney, Rolls Royce Allison, Honeywell Engines and Systems, Southwest Research Institute, Purdue University, University of Illinois, North Dakota State University, Rensselaer Polytechnic Institute

Points of Contact:

Government

Dr. Craig Hartley
 U.S. Air Force, AFOSR/NA
 801 North Randolph Street
 Mail Room 732
 Arlington VA, 22203-1977
 Phone: (703) 696-8523
 Fax: (703) 696-8451
 Email: craig.hartley@afosr.af.mil

Government

Dr. Jeffrey R. Calcaterra
 U.S. Air Force
 AFRL/MLLMN, Bldg. 655
 2230 Tenth St., Suite 1
 WPAFB, OH 45433-7817
 Phone: (937) 255-1360
 Fax: (937) 656-4840
 Email: jeffrey.calcaterra@afri.af.mil

Contractor

Dr. Joseph P. Gallagher
 Univ. of Dayton Research Institute
 300 College Park
 Dayton, OH 45469
 Phone: (937) 229-2349
 Fax: (937) 229-3712
 Email: gallagher@udri.udayton.edu

2.6 Future Efforts

FY 01-06

Background

As a result of previously described research, considerable insight has been gained in the area of thresholds for crack initiation and crack propagation under high cycle fatigue. Specifically, research on crack initiation under various mean loads and biaxial stress states and crack growth threshold investigations with different load histories has pointed the way to development of engineering solutions to relevant HCF design problems. This insight, on the other hand, has raised some fundamental questions about fatigue thresholds in general which, if answered, would enable the development of a more robust damage tolerant design system for HCF. Additionally, future turbine engines will have significant differences from those currently flying today. These engines will have components that must be fully characterized with respect to HCF. Some of the critical issues require continued basic research and are addressed below.

Planned Work

- ❖ ***Probabilistic HCF Life Prediction.*** FY 01-02.* This program will be dedicated to determining the effect of microstructural variations on the HCF properties of Ti-6V-4Al. Probabilistic variations of the material microstructure will be analyzed to provide distributions of material strength and endurance limit.
- ❖ ***Advanced High Cycle Fatigue Mechanics.*** FY 02-04.* This program will analyze the following areas of basic research:
 - Load history and spectrum loading effects
 - Multiaxial fatigue
 - Notch fatigue/stress gradients
 - Residual stress effects
 - Frequency and time-dependent effects

All of these issues have to be addressed adequately in order to be able to establish fatigue thresholds for HCF. Most have been addressed partially or empirically under the present HCF program. The intent of this research is to establish methodologies that predict HCF behavior on a more fundamental basis. This will enable a more reliable basis for extrapolating behavior beyond the conditions under which a database is obtained and allows scale-up from laboratory specimens to components.

- ❖ ***HCF Properties of Welds on Nickel-Based Alloys.*** FY 02-06.* Future turbine engines will rely heavily on Integrally Bladed Rotors (IBRs). These have several structural advantages over traditional bladed disks including lower weight and better resistance to resonant stresses. However, a suitable maintenance procedure for IBRs must be developed in order to ensure that whole assemblies are not discarded due to damage on one blade. One candidate for blade repair is welding a patch over the damaged region or welding on an entirely new airfoil. Both of these

procedures are problematic because current welding methods do not reproduce the parent material microstructure. The proposed program will evaluate industry methods for weld repair, characterize the HCF life debit and suggest improvements to material microstructure and repair procedure. In addition, the program will evaluate other modern welding techniques in order to determine which repair maximizes HCF tolerance

(*) Dates are subject to change.

Points of Contact:

Government

Dr. Theodore Nicholas
U.S. Air Force
AFRL/MLLMN, Bldg. 655
2230 Tenth St., Suite 1
Wright-Patterson AFB, OH 45433-7817
Phone: (937) 255-1347
Fax: (937) 656-4840
Email: theodore.nicholas@afrl.af.mil

Government

Dr. Jeffrey R. Calcaterra
U.S. Air Force
AFRL/MLLMN, Bldg. 655
2230 Tenth St., Suite 1
Wright-Patterson AFB, OH 45433-7817
Phone: (937) 255-1360
Fax: (937) 656-4840
Email: jeffrey.calcaterra@afrl.af.mil

2.7 Conclusion

The Materials Damage Tolerance Action Team dramatically increased the propulsion community’s understanding of turbine engine high cycle fatigue. Specifically, this Team is helping to implement and validate a foreign object damage life model and a fretting hybrid modeling approach. The Materials Team also developed several unique HCF capabilities, including a realistic fretting bench test, a high-temperature fretting fatigue rig, and new models for life prediction in the presence of high stress gradients. Progress made on the STOA Ti-6Al-4V alloy will be extended to both Ti-17 β and PWA 1484 over the course of the upcoming year.

3.0 INSTRUMENTATION



BACKGROUND

The Instrumentation Action Team (Instrumentation AT) has the responsibility of fostering collaboration between individual HCF instrumentation efforts with the overall goal of combining with the Forced Response and Component Analysis ATs to better determine alternating stresses to within 20%. The Instrumentation AT provides technical coordination and communication between active participants involved in HCF measurement, sensor, data processing, and engine health monitoring technologies. Technical workshops have been organized on at least an annual basis and summaries of these workshops are disseminated to appropriate individuals and organizations. The Chair, Co-Chair, and selected Instrumentation AT members meet as required (estimated quarterly) to review technical activities, develop specific goals for instrumentation and engine health monitoring programs, and coordinate with the TPT and IAP. The Chairman (or Co-Chair) of the Instrumentation AT keeps the TPT Secretary informed of AT activities on a frequent (at least monthly) basis. This AT includes members from Government agencies, industry, and universities who are actively involved in instrumentation technologies applicable to engine HCF. The team is to be multidisciplinary with representatives from multiple organizations representing several component technologies as appropriate. The actual membership of the AT may change in time as individuals assume different roles in related projects.

ACTION TEAM CHAIRS



Chair
Ms. Kelly Navarra
U.S. Air Force, AFRL/PRTF
1950 Fifth Street, Bldg. 18D
Wright-Patterson AFB, OH 45433-7251
Phone: (937) 255-2734
Fax: (937) 255-2660
Email: kelly.navarra@wpafb.af.mil



Co-Chair
1Lt Brian Beachkofski
U.S. Air Force, AFRL/PRTC
1950 Fifth Street, Bldg. 18D
Wright-Patterson AFB, OH 45433-7251
Phone: (937) 255-2326
Fax: (937) 255-2660
Email: brian.beachkofski @wpafb.af.mil

INTRODUCTION

The following pages summarize the schedules, backgrounds, and recent progress of the current and planned projects managed by this action team.

Instrumentation Research Schedule

Product	FY95	FY96	FY97	FY98	FY99	FY00	FY01	FY02	FY03	FY04	FY05	FY06
3.1 Improved Non-Contacting Stress Measurement System (NSMS)												
3.1.1 Improved NSMS Hardware		████████████████████										
3.1.2 Alternate Tip Sensors			████████████████████									
3.1.3 Enhanced NSMS Data Processing Capability					████████████████████							
3.1.4 Spin-pit Validation of NSMS					████████████████████							
3.1.5 High-Temperature NSMS Sensor Development								████████████████████				
3.1.6 Dual Use Science and Technology (DUST) Program								████████████████████				
3.2 Environmental Mapping System												
3.2.1 Pressure/Temperature Sensitive Paint (PSP/TSP)	████████████████████	████████████████████	████████████████████	████████████████████	████████████████████	████████████████████	████████████████████	████████████████████				
3.2.1.1 PSP: Improved Dynamic Response			████████████████████									
3.2.1.2 PSP: Light Emitting Diodes					████████████████████							
3.2.2 Comparison Testing / Air Etalons		████████████████████	████████████████████	████████████████████	████████████████████							
3.2.3 Validation of Paint/Optical Pressure Mapping											████████████████████	
3.2.4 Wireless Telemetry						████████████████████	████████████████████					
3.2.5 MEMS Pressure Sensor												
3.2.6 Aluminum Nitride (AlN) Sensors						████████████████████	████████████████████					
3.3 Improved Conventional Sensors												
3.3.1 Non-Optical NSMS Sensor Development (Eddy Current)					████████████████████	████████████████████	████████████████████					
3.4 Development of Long-Life, Less Intrusive Devices												
3.4.1 Advanced Thin-Film Dynamic Gages	████████████████████	████████████████████	████████████████████	████████████████████	████████████████████	████████████████████	████████████████████					
3.4.2 Advanced High-Temperature Thin-Film Dynamic Gages		████████████████████	████████████████████	████████████████████	████████████████████	████████████████████	████████████████████					

3.1 Improved Non-Contact Stress Measurement System (NSMS)

To date, prediction of aerodynamic forcing functions has been difficult or impossible due to lack of Computational Fluid Dynamics (CFD) fidelity, structural modeling accuracy, instrumentation effects, and insufficient characterization of instrumentation installation effects. The purpose of the projects described below is to develop an advanced generation NSMS (Fig. 47) capable of detecting simultaneous integral-order modes with a 5X improvement in accuracy, and to provide the ability to accurately convert the measured tip deflection to a dynamic stress map.

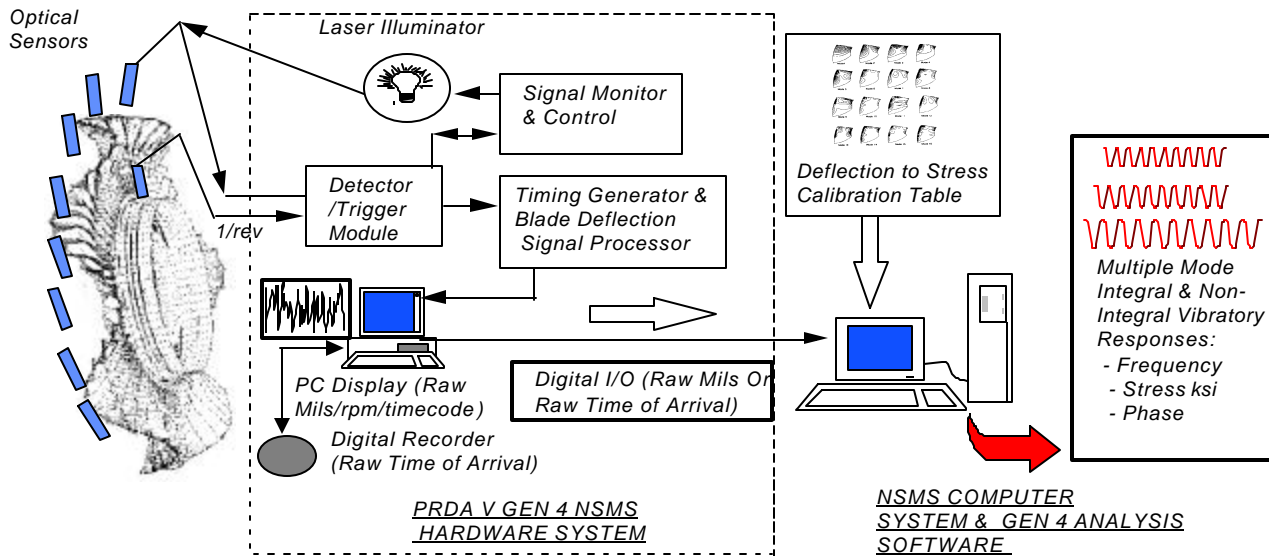

FIGURE 47. Next-Generation NSMS Overview

3.1.1 Improved Non-Contact Stress Measurement System (NSMS) Hardware (Generation 4) FY 96-01

Recent Progress

Work is nearing completion on all four major subsystems of the NSMS Hardware: Electro-Optics, Blade-Deflection Signal Processor (BDSP), Blade Timing Generator (BTG), and the Optical Line probe. The first end-to-end hardware checkout of the subsystems was successfully conducted in an electronics laboratory at Arnold Air Development Center (AEDC) in September 2000. Additionally, data files were successfully transferred from the BDSP to the Gen 4 Software System under development by AEDC. Twelve channels of hardware should be available to meet the scheduled validation test planned for Advanced Turbine Engine Gas Generator (ATEGG) XTC67/1. Generation 4 optical probes being procured under the ATEGG contract are in final assembly and will be available for installation into XTC67/1 for validation testing.

Electro-Optic Development:

Due to spool up time and funding issues associated with re-subcontracting this task to Arnold Engineering Development Center (AEDC), this task is not fully completed. However, major progress has been made and critical functionality was successfully demonstrated during the end-to-end system checkout conducted at AEDC. It is anticipated that the system will be capable of meeting the system specifications and that a minimum of 12 channels will be operational to meet the scheduled validation testing planned for ATEGG XTC67/1. Major components for the full 24 channels of hardware have been received. However, some, but not all, have been fully assembled and checked out. Subassembly checkouts uncovered the need for hardware redesign/replacement in two primary areas: (1) coupling of the single mode laser beam to the optical fiber and (2) unacceptable noise traced to the power supplies for biasing the avalanche photo-detectors. Funding has not yet been resolved to correct and procure replacement hardware for the full complement of 24 channels.

Blade Deflection Signal Processing (BDSP) Development:

Procurement of the full 24 channels of hardware is complete. System software configurations for eight-, 16-, and 24- channel configurations are operational. System documentation has been delivered and the system is ready for validation testing on ATEGG XTC67/1. A member of the Pratt & Whitney (P&W) NSMS engineering group has received initial training in the setup and operation of the BDSP & BTG systems.

Blade Timing Generator Development:

The full 24 channels of hardware is completed and checked out. System documentation has been delivered and the system is ready for validation testing on XTC67/1.

Optical Line Probe Development:

Design, documentation, and laboratory evaluations have been completed. One probe (for laboratory use only) has been delivered to AEDC for use in laboratory evaluations of the Electro Optics subsystem. The design has been adapted for use on the validation testing of the Gen 4 hardware on ATEGG XTC67/1. Twelve probes being fabricated under the ATEGG contract are in final assembly. A commercial vendor is providing the high-temperature five-lens optical subassembly used in these probes.

Gen 4 Hardware Interface to Gen 4 Data Processing Systems:

During the end to end checkout of the Gen 4 Hardware conducted at AEDC, data files were successfully read from the BDSP reflective memory into the Gen 4 Data Processing System being developed by AEDC. Additionally, software routines to interface the Gen 4 Hardware to P&W's on-stand NSMS Data Acquisition system are nearing completion. P&W's NSMS Data Acquisition system will be utilized for the validation testing to be conducted in the near term on ATEGG XTC67/1.

Participating Organizations: Pratt & Whitney, Honeywell Engines and Systems, Arnold Air Development Center (AEDC)

Points of Contact:

Government

Ms. Kelly Navarra
U.S. Air Force, AFRL/PRTF
1950 Fifth Street, Bldg. 18D
Wright-Patterson AFB, OH 45433-7251
Phone: (937) 255-2734
Fax: (937) 255-2660
Email: kelly.navarra@wpafb.af.mil

Contractor

Mr. Woodrow Robinson
Pratt & Whitney
M/S 723-10, P.O. Box 109600
West Palm Beach, FL 33410-9600
Phone: (561) 796-4809
Fax: (561) 796-1442
Email: robinsw@pwfl.com

3.1.2 Alternate Tip Sensors *FY 97-01*

Recent Progress

As part of the Fourth Generation NSMS development effort, a study of alternate (i.e., non-optical) NSMS sensors has been initiated. The motivation for this study arises principally from problems associated with applying optical sensors, namely installation complexity and susceptibility, to optical contamination. These problems are of paramount importance in flight test and engine health monitoring applications (but are of less concern in ground-based engine testing). A sensor capability specification was prepared with input from the members of the Fourth Generation NSMS design team. This sensor specification defines the requisite characteristics of sensors to be used for engine health monitoring and Third and Fourth Generation NSMS applications. This sensor specification was used as a basis for evaluating the suitability of alternative sensor technologies for Fourth Generation NSMS applications.

The alternate sensor feasibility study is a subtask of the PRDA-5-funded Fourth Generation NSMS development program. This subtask was accomplished by Rolls-Royce Corporation (Allison Advanced Development Company). The objective of the subtask was to define the necessary and desirable characteristics—such as spatial resolution, depth of field, sensitivity, temperature range, and bandwidth—that an NSMS blade passage sensor would need to possess in order to implement each of the four generations of NSMS systems, where the NSMS generations are defined by functional capability as follows:

- Generation 1. Flutter Monitor - Deflection Only
Analog Signal, Single Probe,
No Algorithms for Stress
- Generation 2. Multi-Probe Capability, Frequency And
Amplitude Of Non-Integral Order Modes,
1st Computer Based NSMS, Algorithms For
Frequency and Modes.
- Generation 3. Frequency and Amplitude of Single Mode
Integral Order Blade Vibrations, Limited
Algorithms for Stress.

Generation 4. Frequency and Amplitude of Multi-Mode Integral Order Blade Vibrations, Algorithms for Stress.

Recent Progress

The NSMS sensor capability specification integrated the input from all the participating organizations of the Propulsion Instrumentation Working Group (PIWG) NSMS team, drawing on the team's extensive NSMS experience. The key NSMS sensor capabilities are listed below. Noteworthy are the stringent bandwidth and spatial resolution specifications for Generation 4 HCF applications.

NSMS Generation	Bandwidth (Rise Time)	Effective Spatial Resolution
Basic LPC/Fan Health	88 kHz (4 microseconds)	5 mils (S) 10 mils (L) *
Gen 3	350 kHz (1 microseconds)	2 mils
Gen 4	12 MHz (30 nanoseconds)	0.1 mil

(*) "S" denotes "small engine." "L" denotes "large engine."

A review of the state of the art of sensor technology and a survey of commercially available sensors was undertaken to identify alternate candidate alternate sensors (e.g. eddy current sensors, capacitive sensors, etc.) that are potentially suitable for implementing each of the four generations of NSMS systems. The program scope has been limited to reviewing the literature and contacting sensor vendors and developers. No actual sensor testing has been undertaken as part of this subtask. The results to date are that no non-optical NSMS sensor is demonstrably capable of achieving the requisite spatial resolution and bandwidth required for Generation 4 HCF applications.

Participating Organizations: Rolls-Royce

Points of Contact:

Government

Ms. Kelly Navarra
 U.S. Air Force, AFRL/PRTF
 1950 Fifth Street, Bldg. 18D
 Wright-Patterson AFB, OH 45433-7251
 Phone: (937) 255-2734
 Fax: (937) 255-2660
 Email: kelly.navarra@wpafb.af.mil

Contractor

Mr. Thomas Bonsett
 Rolls-Royce
 Speed Code W03A, P.O. Box 420
 Indianapolis, IN 46206-0420
 Phone: (317) 230-3448
 Fax: (317) 230-4246
 Email: tbonsett@iquest.net

3.1.3 Enhanced Data Processing Capability for Generation 4 & 5 NSMS Development

FY 99-01

Background

Improved NSMS processing and analysis capabilities will provide the Government with test-ready analysis tools to support High Cycle Fatigue evaluations for improving life prediction of advanced turbine engine components by enabling an on-line capability to measure rotor blade vibratory deflection and convert to stress for all blades of instrumented rotors (Fig. 48). This effort will provide rapid analyses to support on-line test direction, next-test planning, and early identification of structural-fatigue problems before engines are put into production.

Major products to be delivered are:

- Gen 4 - Advanced Non-Contact Stress Measurement System (NSMS) software, hardware, and interfacing software to use the Gen 4 NSMS Front-End measurement system in an integrated turbine engine blade stress evaluation architecture
- Gen 5 - Adaptive finite model supplements to use Gen 4 NSMS modal identification algorithms to produce full blade, stress/strain contours
- A fully integrated NSMS, including the Gen 4 Front-End (G4F), Gen 4 Processor (G4P), and the Gen 5 Structural Dynamic Response Analysis Code (SDRAC)

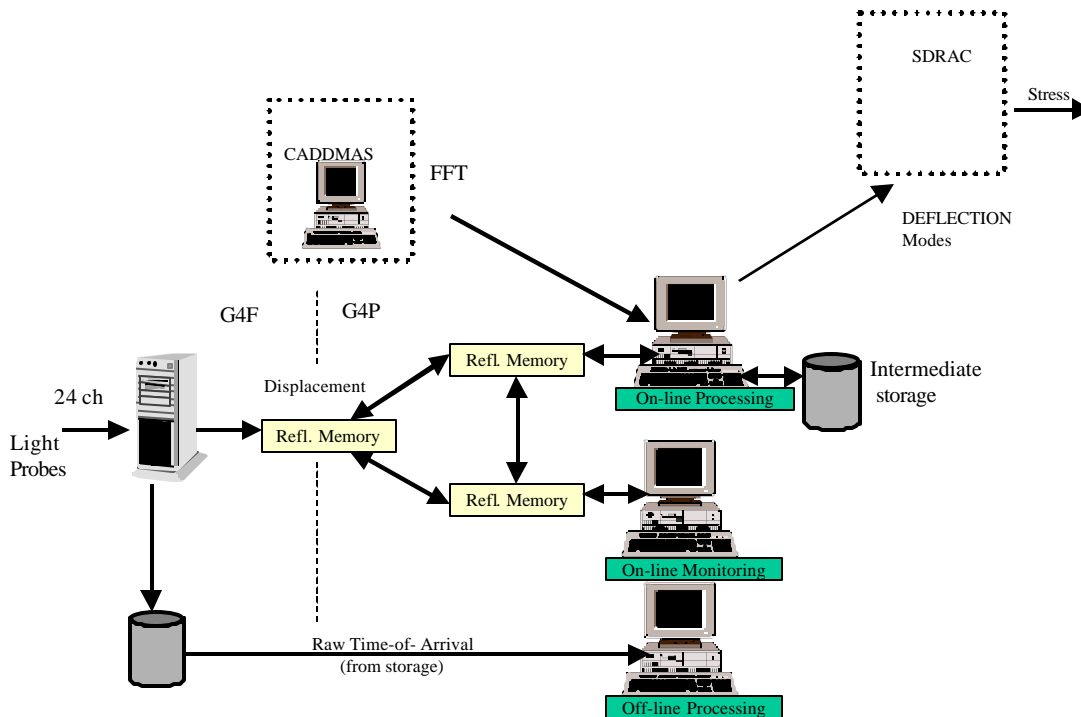

FIGURE 48. Data Processing for Generation 4 & 5 NSMS Development

Recent Progress

Work efforts in 2000 were focused on coordination with developers of Generation 4 Front-End in defining the G4F-to-G4P interface requirements, and development of G4P algorithms/software. The Gen 5 effort, to convert deflection to stress, will use the SDRAC, which is being developed at AEDC. The G4P-to-SDRAC interface implementation is planned for fiscal year 2002. The BDSF processing hardware for future buildup of the AEDC G4F was procured. The Preliminary Design Review (PDR) was completed. Software development is being documented under Government guidelines.

Coordination with G4F development

Close coordination with the developers the G4F was necessary to ensure compatibility with the (1) time-of-arrival to deflection conversion algorithms, (2) data structures organization and content, (3) time-of-arrival data storage, and (4) time tagging of data. A blade-windowing algorithm was provided to the G4F developers for producing a final G4F blade windowing algorithm. Data structure formats, test configuration details, blade arrival timing, and time tagging issues were cooperatively reviewed for definition and resolution. Planning for the upcoming ATEGG test was initiated.

G4P algorithms and software development

Algorithm and software development for the G4P continued with development and prototyping of the Sine Wave Analysis Technique (SWAT), Single Blade Analysis (SBA) processing, real-time monitoring capability (G4M), the NSMS data simulator, and the test description header editor. SWAT will resolve blade vibration modes within one revolution for both integral and non-integral vibrations. Single Blade Analysis, based on FFT processing, provides an alternative method for defining non-integral vibrations for individual blades. Real-time monitoring is being developed to provide real-time critical engine health monitoring information. The NSMS simulator, residing in the G4F, sends simulated vibratory deflection data (raw time-of-arrival data option) across the reflective memory to check the G4P/G4M performance during development and prior to application testing. The *test description header editor* will allow editing of the test description header located in reflective memory or in recorded data.

Verification and validation plans

The NSMS Simulator will be used to exercise the G4P/G4M during development. NSMS data recorded from engine tests (e.g., ATEGG) will be processed on the G4P and SDRAC for comparison with strain gage and other NSMS system results. Verification tests will continue throughout the developmental stages. The completed, fully integrated system will be validated using simulated and test data.

Future Plans and Schedule

System development and integration will continue into fiscal 2001-02 (Fig.49). The four basic algorithms (SWAT, SBA, Traveling wave Analysis, Single Degree of Freedom) are planned to be in place in fiscal year 2001, with completion in fiscal year 2002. Procurement of two 24-channel NSMS systems is underway with fabrication and checkout to be completed in fiscal 2002. Completion of the NSMS developmental effort in fiscal 2002 depends on the readiness of the G4F design for reproduction. The status of the G4F will be determined after the final acceptance test results are completed and an evaluation of required improvements are assessed.

Schedule

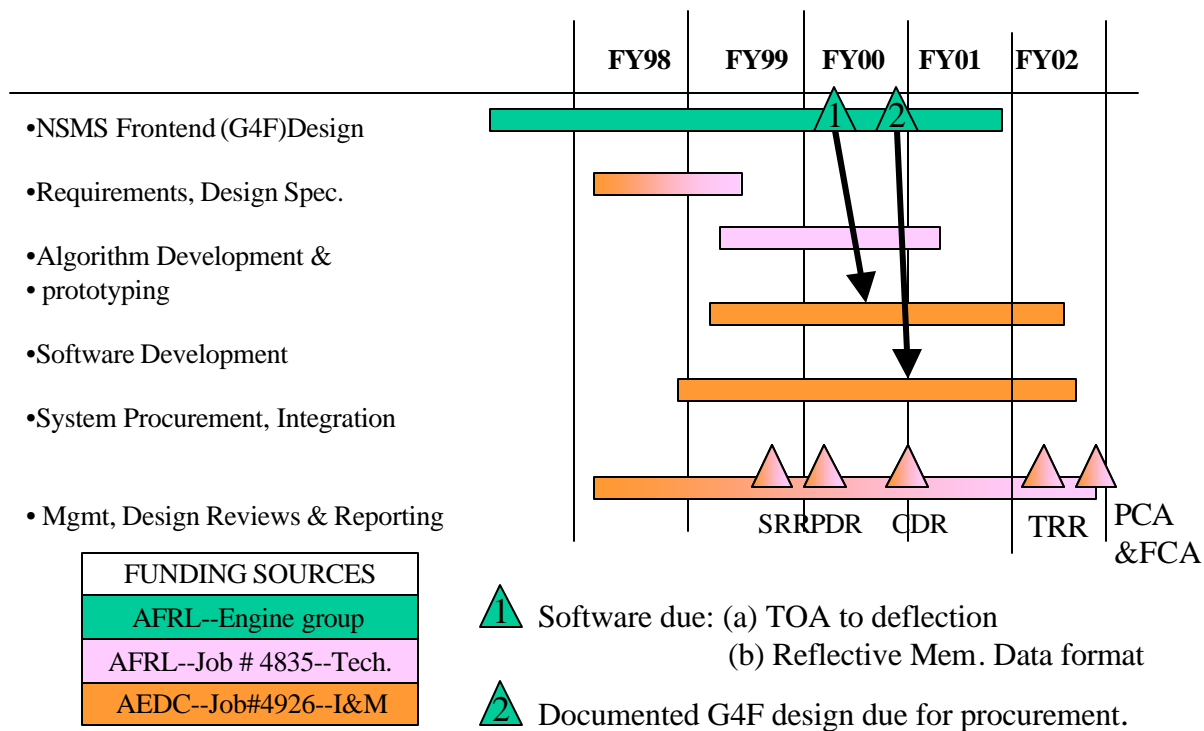

FIGURE 49. NSMS Development Schedule

Participating Organizations: Arnold Air Development Center (AEDC)/Sverdrup, Honeywell Engines and Systems, Rolls-Royce

Points of Contact:

Government

Ms. Kelly Navarra
 U.S. Air Force, AFRL/PRTF
 1950 Fifth Street, Bldg. 18D
 Wright-Patterson AFB, OH 45433-7251
 Phone: (937) 255-2734
 Fax: (937) 255-2660
 Email: kelly.navarra@wpafb.af.mil

Contractor

Mr. Henry Jones
 Arnold Air Development Center/Sverdrup
 1103 Avenue C, M/S 1400
 Arnold AFB, TN 37389-1400
 Phone: (931) 454-7750
 Fax: (931) 454-6187

3.1.4 Spin-Pit Validation of NSMS

FY 99-01

Recent Progress

The development of blade excitation techniques to be used in vacuum spin pits is accompanied by the requirement to measure the amplitude and frequency of the excited blade resonant vibrations. If the standard spin-test procedure is used, one of suspending the rotor on the end of a flexible spindle, with the drive turbine outside the vacuum chamber, the application of NSMS techniques is somewhat different than in a component or engine test. In the spin pit, rotor excursions of .010-.100 inches can be experienced during start-up, lubricating oil contamination patterns are not easily controlled, and some blade excitation techniques (such as vacuum-oil jets) prohibit the use of laser light probes. However, in a spin test, there is greater access around the blades to position sensors.

In fiscal year 2002, air-jet and eddy-current blade excitation techniques were used for the first time (and oil-jets were installed) in the engine-scale Navy Rotor Spin Research Facility at the Naval Postgraduate School. Blade response was recorded using strain gage and (NSMS) capacitance probes. Also, a Front-End NSMS two-channel (extendable to four) laser light probe system was set up and proven on a large-scale research axial compressor, in which the blade tip motion could be recorded using strobe-photography. A schematic of the system is shown in Figure 50, and a photograph of the fiber optic components and the Hood Technology signal-to-PC interface board that were used is shown in Figure 51. Heath's method to determine resonance was programmed and applied to compressor data taken by Hood Technologies at AFRL/WPAFB (Figs. 52 & 53).

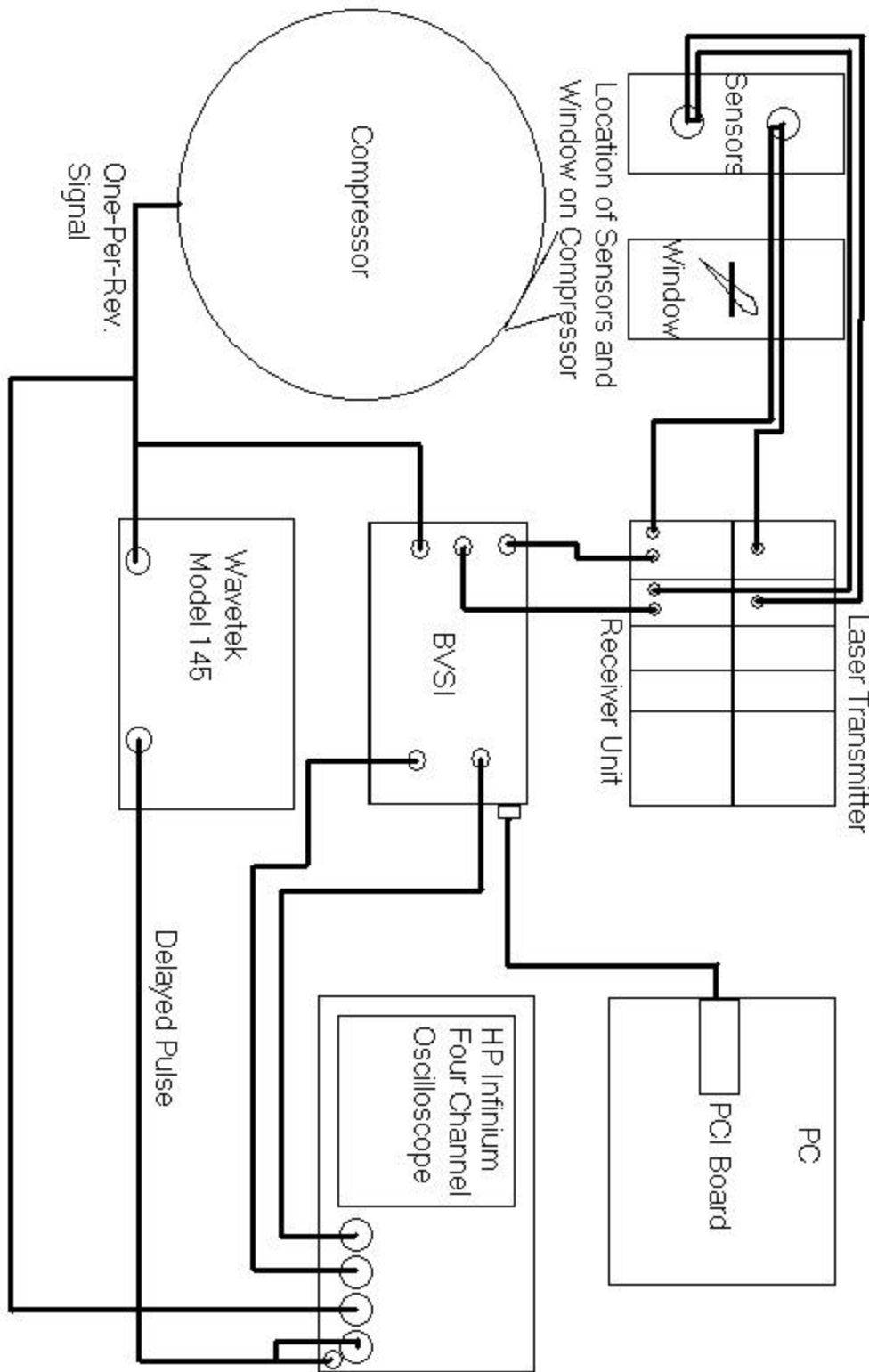

FIGURE 50. Light-Probe NSMS Validation Measurements on a 36-inch Diameter Two-Stage Compressor. Plans are to apply both laser-light and two types of capacitance probes in blade-excitation spin tests in FY 01.

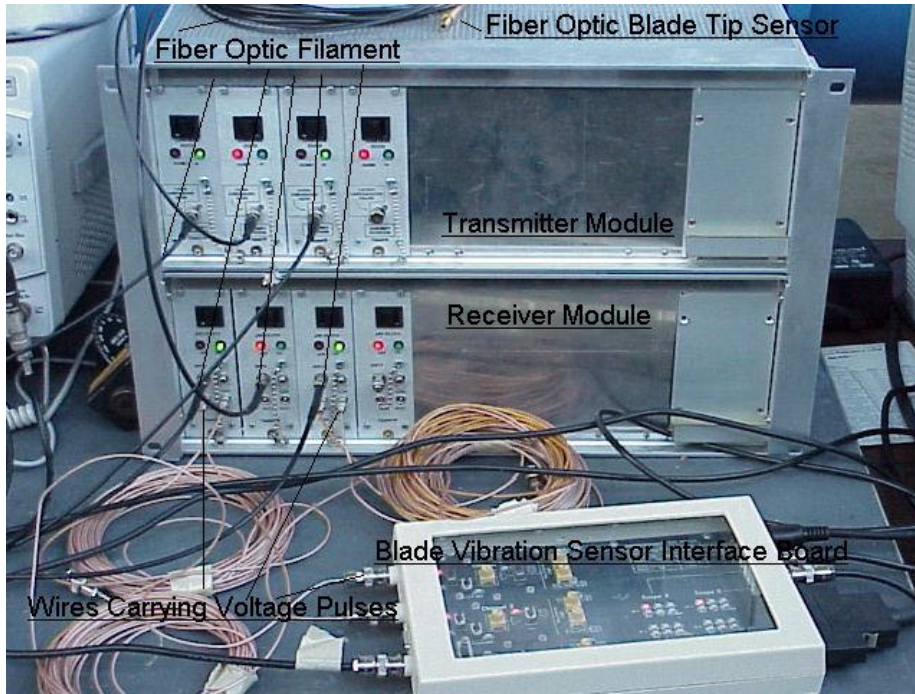

FIGURE 51. Light Probe System and Signal-PC Interface Board

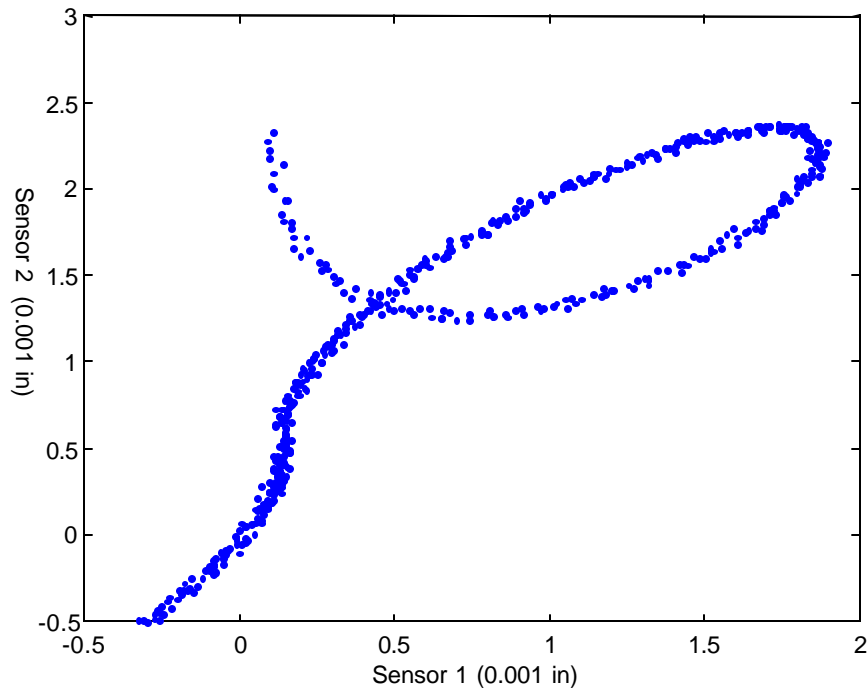

FIGURE 52. Heath's Method Applied to Determine Blade Resonance: NSMS Probe Data through Resonance

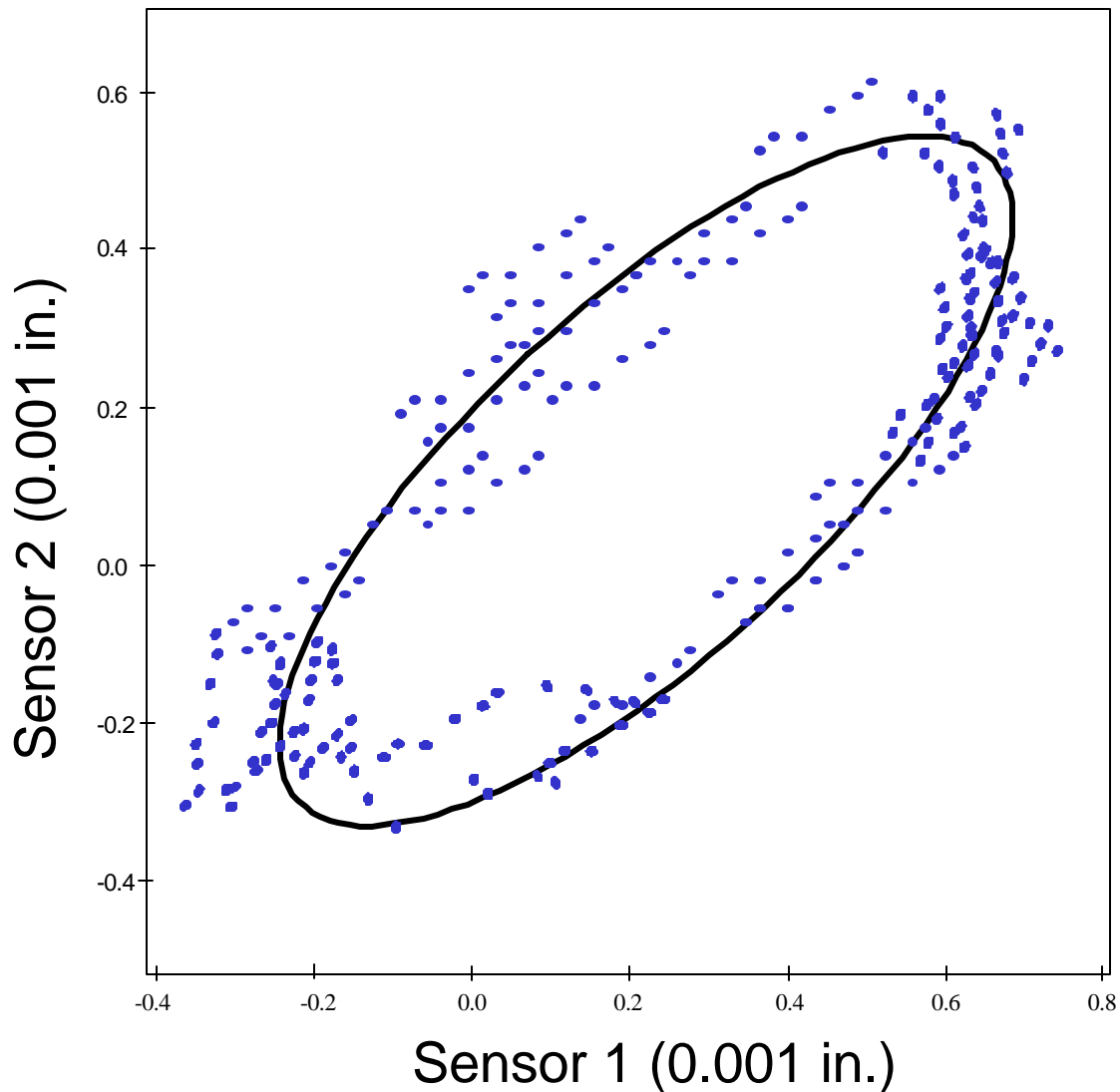

FIGURE 53. Heath's Method Applied to Determine Blade Resonance: Least Squares Fit to an Ellipse

Participating Organizations: U.S. Navy, Hood Technology Corp., Exsell

Points of Contact:

Government

Dr. Raymond Shreeve
 U.S. Navy
 Turbopropulsion Laboratory
 Naval Postgraduate School
 699 Dyer Road, Room 137
 Monterey, CA 93943-5106
 Phone: 831-656-2593
 Fax: 831-656-2864
 Email: shreeve@nps.navy.mil

Contractor

Dr. Andy vonFlotow
 Hood Technology Corporation
 1750 Country Club rd.
 Hood River, OR 97031
 Phone: 541-387-2288
 Fax: 541-387-2266
 Email: AvonFlotow@cs.com

3.1.5 High-Temperature NSMS Sensor Development

FY 01-04

Planned Work

NSMS sensors do not currently have the high-temperature capability necessary to adequately monitor blade stress in small engines. The purpose of the project is to develop high-temperature probes to interface with the existing Generation 4 NSMS signal processing hardware. Light probes for ground test applications and Eddy Current/Capacitance probes for Engine Health Monitoring will be investigated. A major emphasis of this project will be balancing the increased temperature capability with sensor life and accuracy.

Participating Organizations: Air Force Research Laboratory (AFRL)

Point of Contact:

Government

Ms. Kelly Navarra
U.S. Air Force, AFRL/PRTF
1950 Fifth Street, Bldg. 18D
Wright-Patterson AFB, OH 45433-7251
Phone: (937) 255-2734
Fax: (937) 255-2660
Email: kelly.navarra@wpafb.af.mil

3.1.6 Dual Use Science and Technology (DUST)

FY 01-04

Planned Work

Two Dual Use Science and Technology (DUST) Programs have been awarded supporting this effort. The first DUST is with Honeywell/Excell, Inc. and the second effort is with Williams International/Hood Technologies, Inc. Efforts to bring these two programs on contract are underway.

Participating Organizations: Air Force Research Laboratory (AFRL)

Point of Contact:

Government

Ms. Kelly Navarra
U.S. Air Force, AFRL/PRTF
1950 Fifth Street, Bldg. 18D
Wright-Patterson AFB, OH 45433-7251
Phone: (937) 255-2734
Fax: (937) 255-2660
Email: kelly.navarra@wpafb.af.mil

3.2 Environmental Mapping System

To date, prediction of aerodynamic forcing functions has been difficult or impossible due to lack of Computational Fluid Dynamics (CFD) fidelity, lack of structural modeling accuracy, instrumentation effects, and insufficient characterization of instrumentation installation effects. The purpose of the tasks described below is to develop an optical pressure and temperature measurement system to non-intrusively measure the dynamic pressure and temperature distribution over the surface of the blade.

3.2.1 Pressure/Temperature Sensitive Paint (PSP/TSP)

FY 95-02

Recent Progress

Over the past year, extensive work has been done to process the data obtained from last year's Compressor Research Facility (CRF) test. Many issues involving post-processing software have been resolved. NASA has participated in the PSP data evaluation and comparison to CFD. An ASME journal paper on the effort is now in the final editing stages.

Participating Organizations: ISSI, NASA GRC

Points of Contact:

Government

Ms. Kelly Navarra
U.S. Air Force, AFRL/PRTF
1950 Fifth Street, Bldg. 18D
Wright-Patterson AFB, OH 45433-7251
Phone: (937) 255-2734
Fax: (937) 255-2660
Email: kelly.navarra@wpafb.af.mil

Contractor

Dr. Larry Goss
ISSI
2786 Indian Ripple Rd.
Dayton, OH 45440-3638
Phone: (937) 252-2706
Fax: (937) 656-4652
Email:
crafton@ward.appl.wpafb.af.mil

3.2.1.1 Pressure Sensitive Paint (PSP): Improved Dynamic Response *FY 97-98*

Background

Characterizing the transient response of PSPs to unsteady pressure flows is a critical aspect in understanding HCF events. A group led by B. Carroll previously developed an apparatus capable of delivering a step change in pressure, and reported response times for proprietary PSP formulations tested on the order of one second. In previous work from our group, a pressure-jump apparatus was constructed and used to measure PSP response times on the order of one millisecond.

Recent Progress

During the previous months, efforts have been focused on the temporal response characteristics of Pressure Sensitive Paint (PSP). Pressure Sensitive Paint was applied to a stator blade (wake generator) in the Compressor Aerodynamics Research Laboratory (CARL) at Wright Patterson Air Force Base in an effort to determine the temporal pressure measurement characteristics of current PSP formulations. The goal was to make time-resolved pressure measurements at a single point on the wake generator. The results of this test indicate that the large-amplitude pressure disturbance (shock) generated by the passing of the rotor blade can be detected with current PSP technology. However quantitative pressure measurement will require that the temporal response of the PSP be improved by about two orders of magnitude. Subsequent efforts have been focused on improving these temporal response characteristics of the current PSP formulations while maintaining the necessary mechanical stability of the paint. Several current PSPs were modified in an effort to enhance the porosity of the paint layer. While the results of the modified formulations indicate a significant improvement in the temporal response of the PSP, the resulting paints lacked the mechanical stability required for this application. To determine the response of the new Sol Gel-based PSP samples to pressure, they were tested in the shock tube shown in Figure 54. The response of these samples to the initial shock wave is shown in Figure 55. This new Sol Gel-based PSP formulation shows response times of better than 1 kHz and maintains excellent mechanical properties.

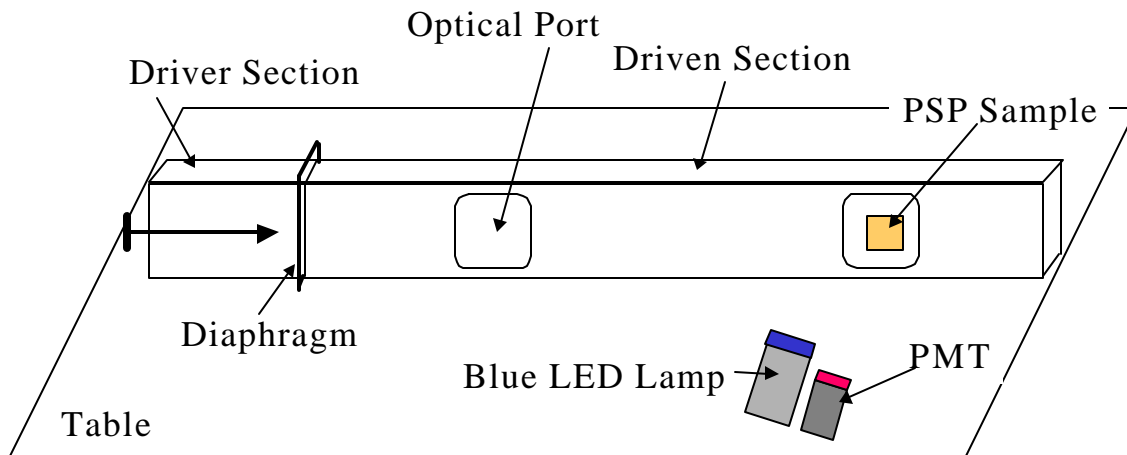

FIGURE 54. Experimental Setup for PSP Response to a Shock

Sol Gel on Dupont

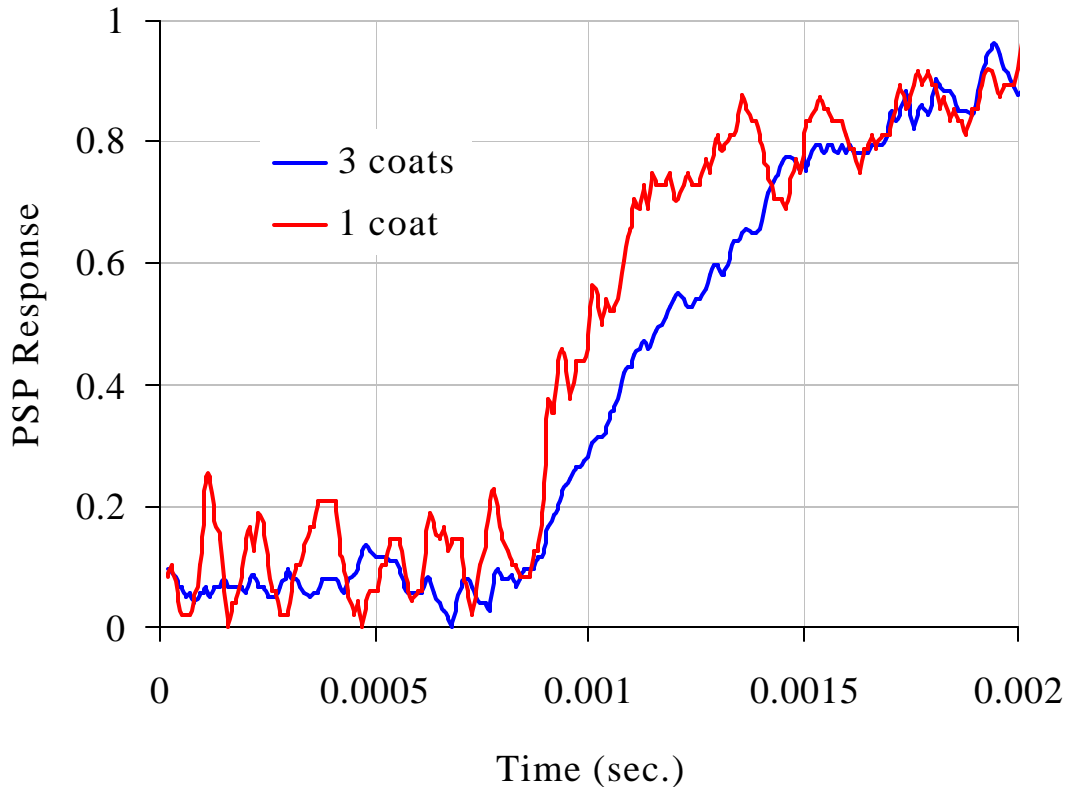

FIGURE 55. Response of Sol-Gel on DuPont to the Initial Shock Wave in the Shock Tube

Time-Resolved Pressure Measurements on a Wake Blade in the CARL

There is significant interest in PSP from the compressor research community for the non-intrusive measurements of both mean and time-resolved pressures on compressor rotor and stator blades. To date, several measurements of mean pressure on rotor blades have been made, but no unsteady measurements have been reported in a compressor. The stator blade on a compressor offers a unique environment for testing the unsteady pressure measurement capabilities of PSP. The stator blade is subjected to large-amplitude, temporally-varying pressure disturbance as the shock from the rotor blade sweeps across the stator surface. The CARL provides the necessary optical access to the first-stage stator blade (or wake generator) to perform optical diagnostics. An experiment with the goal of making time-resolved pressure measurements on a stator blade in the CARL was conducted.

A single-point time-resolved PSP data acquisition system was constructed using a continuous wave (CW) laser, a photo-multiplier tube (PMT), and the optics and filters shown in Figure 56. The stator blade was painted with ruthenium bathophenanthroline chloride in a Sol Gel binder. This PSP has previously been shown to respond to pressure disturbances at up to 5.7 kHz, but the PSP response was attenuated by over 40 dB at this frequency. The PSP was excited using 532-nm radiation from a Spectra-Physics Millennia laser, and the luminescence from the PSP was collected and passed through

a 610-nm long pass filter onto a photo-multiplier tube. The signal from the PMT was digitized using a LeCroy 9314 Oscilloscope.

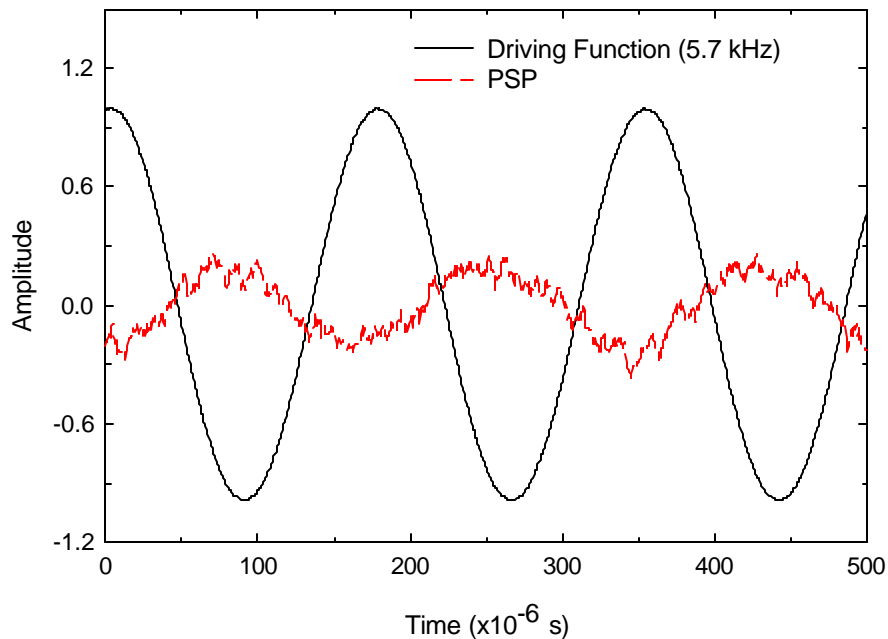

FIGURE 56. PSP Response to a 0.2-psi Pressure Modulation at 5.7 kHz

PSP data was taken at two conditions, 100% and 85% operating speed, corresponding to 13,000 and 11,050 RPM of the rotor. It is worth noting that at 13,000 RPM, the rotor blades are transonic ($M \approx 1.2$), while at 11,050 RPM the rotor blades are subsonic, thus no shock will be generated. The rotor houses 33 blades. With this information, the blade passage frequency can be calculated as 7,150 Hz and 6,077 Hz at 13,000 RPM and 11,050 RPM respectively. Clearly, these frequencies exceed the highest frequency at which PSP data has been observed using the given PSP formulation. However, the amplitude of the pressure disturbance at 13,000 RPM is expected to be about 4 psi due to the presence of the shock. This large pressure disturbance should generate a measurable signal.

During the test, it was observed that real-time conversion of the digitized signal to pressure was not possible due to the low signal-to-noise ratio encountered in the test. Noise sources included low-frequency vibration of the test rig as well as higher-frequency noise in the laser power. While the noise prevented direct conversion of the PSP signal to meaningful pressure data, some insight was gained by analyzing the frequency spectrum of the data. The digitized signal from the PSP at the two test conditions was converted to power spectra using the LeCroy 9314 as a spectrum analyzer. The resulting power spectra are shown in Figure 57 along with the amplitude response of the PSP as a function of frequency. Inspecting the data in Figure 57 reveals peaks at several frequencies at each test condition. Significant spectral content is evident at low frequencies; this is believed to be caused by vibration of the test rig. Peaks at harmonics of 60 Hz are also evident in the data. At the 13,000-RPM test condition a small peak is evident at 7,150 Hz, the previously calculated blade passage frequency, but no peak is evident in the 11,050-RPM power spectra at 6077 Hz. This absence of signal content at the blade passage frequency for the 11,050-RPM data is probably due to the small amplitude of the pressure disturbance at this test condition. Assuming that the system is not responding to pressure at

the 11,050-RPM operating condition allows this data to be viewed as a noise filter. Common electronic and vibrational noise sources can be filtered out of the 13,000-RPM data by subtracting the 11,050-RPM power spectra data from the 13,000-RPM power spectra. This result is shown in Figure 58.

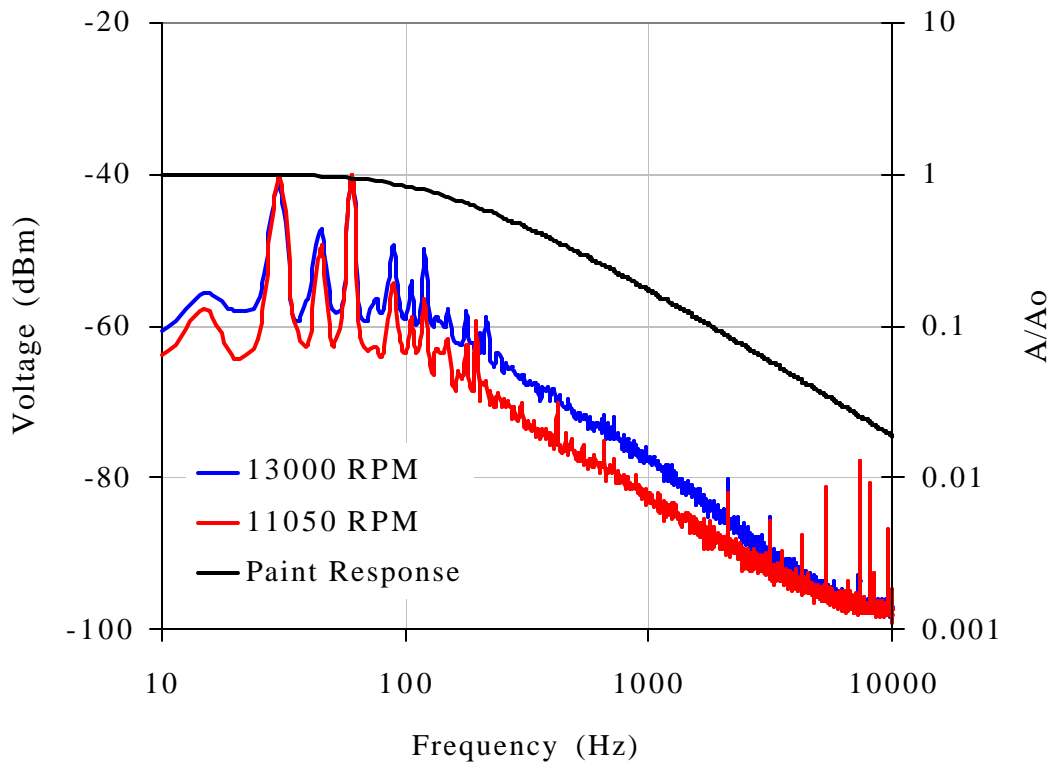

FIGURE 57. PSP Signal from the Wake Generator at 13,000 RPM and 11,050 RPM, and the Amplitude Response of the PSP as a Function of Frequency

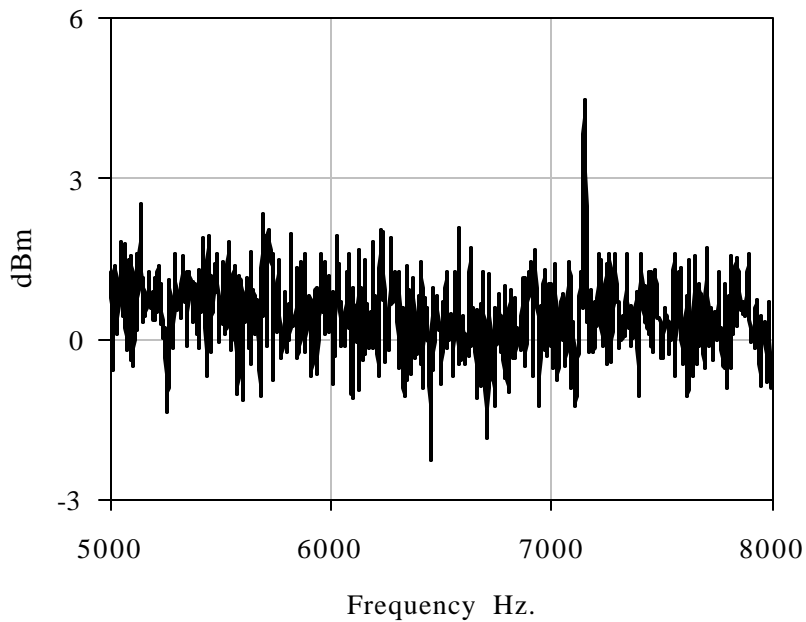

FIGURE 58. Power Spectra of the PSP at 13,000 RPM Minus the Power Spectra of the PSP at 11,050 RPM from 5,000 to 8,000 Hz

While several peaks in the spectra are removed, the peak at the blade passage frequency, 7150 Hz, remains 4 dB above the noise floor. This indicates that the PSP system is responding to the pressure disturbance associated with the passage of the rotor blade.

Participating Organizations: ISSI

Points of Contact:

Government

Ms. Kelly Navarra
U.S. Air Force, AFRL/PRTF
1950 Fifth Street, Bldg. 18D
Wright-Patterson AFB, OH 45433-7251
Phone: (937) 255-2734
Fax: (937) 255-2660
Email: kelly.navarra@wpafb.af.mil

Contractor

Dr. Larry Goss
ISSI
2786 Indian Ripple Rd.
Dayton, OH 45440-3638
Phone: (937) 252-2706
Fax: (937) 656-4652
Email: jordan@ward.appl.wpafb.af.mil

3.2.1.2 Pressure Sensitive Paint: Light Emitting Diodes (PSP-LEDs) *FY 99-00*

Background

The objective of this task is to shed light on critical issues required to ensure that Pressure Sensitive paints (PSPs) and thermographic phosphors (TPs) can be used in high cycle fatigue studies of turbomachinery. The critical issues to be addressed include probe miniaturization and paint/phosphor improvements.

Probe miniaturization requires the development of compact excitation and detection systems. Current excitation sources are heavier, bulkier, more labor-intensive, and costlier than those desired for certain Advanced Turbine Engine Gas Generator (ATEGG) and Joint Turbine Demonstrator Engine (JTDE) demonstrations. In this project, the use of high-power blue LEDs that hold promise for significant improvements in current methods of excitation for both PSPs and TPs will be investigated.

Pressure sensitive paint improvements in time response, survivability, and sensitivity at higher pressures and temperatures, and the use of thermographic phosphors as a means of temperature correction for the PSPs, are also being investigated.

Under this effort, a prototype LED illumination system was developed and demonstrated in an engine test. This test was conducted with Pratt & Whitney through a Cooperative Research & Development Agreement. The deployment of PSP measurements in an engine test cell required two phases of setup: (1) model preparation and painting and (2) instrumentation installation and alignment.

The internal diameter of the bell mouth tested was approximately 75 inches (1.8 m). The circular structure located upstream of the engine inlet (wagon wheel) was used to mount thermocouples. For this test, two symmetrical regions of the upper surface of the bell mouth were painted with a low-speed sol-gel-based PSP. A large quantity of data was acquired from this test, which was considered to be a success. As of the end of 1999, Pratt & Whitney was processing the data and writing a final report, and the effort was scheduled to finish in the summer of 2000.

Recent Progress

No progress has been reported since the 1999 HCF Annual Report was published. The status of the final report is unknown.

Participating Organizations: ISSI

Points of Contact:

Government

Ms. Kelly Navarra
U.S. Air Force, AFRL/PRTF
1950 Fifth Street, Bldg. 18D
Wright-Patterson AFB, OH 45433-7251
Phone: (937) 255-2734
Fax: (937) 255-2660
Email: kelly.navarra@wpafb.af.mil

Contractor

Dr. Larry Goss
ISSI
2786 Indian Ripple Rd.
Dayton, OH 45440-3638
Phone: (937) 252-2706
Fax: (937) 656-4652
Email: jordan@ward.appl.wpafb.af.mil

3.2.2 Comparison Testing/Air Etalons

FY 96-99

Background

The Air Etalon is a sensing concept based on Fabry-Perot interferometry. In its simplest form, a Fabry-Perot etalon consists of two mirrors separated by a certain distance, or gap. When light is incident upon an etalon, optical interference occurs; at certain optical resonance frequencies, virtually all of the incident light is transmitted through the etalon, while at other frequencies most of the light is reflected. The optical resonance frequency depends on the optical path length between the two mirrors—which of course is dependent upon the index of refraction of the material used in the gap between the two mirrors. This fact can thus be utilized to design a pressure sensor based on a Fabry-Perot etalon where the change in optical resonance is monitored as the optical path length changes as a result of changes in pressure. In this effort, both solid and air-gap etalons have been investigated as pressure sensors.

Final Results

The objective of the PRDA 5 funded "Optical Airfoil Pressure Mapping" program was to perform a comparative test of pressure sensitive paints (PSP) and interferometric measurements by means of thin-film Fabry-Perot etalons, two technologies thought to be capable of providing real-time two-dimensional mapping of pressure distributions across fan and compressor airfoil surfaces. By visualizing the forcing functions (i.e., by visualizing the pressure fluctuations across an airfoil surface that induce the vibration modes that result in HCF), optical airfoil pressure mapping was to provide data complementary to that obtained from Non-Contact Stress Measurement Systems (NSMS), which measure the blade stresses that result from these vibration modes.

The intent was to execute a down-selection between these two technologies (PSP and etalons), selecting the more promising technology for further development, with the ultimate goal of demonstrating surface pressure mapping in an actual turbine compressor and fan environment. The pressure sensitive paints tested under this program were supplied by Innovative Scientific Solution (ISSI), the etalon development work was carried out by General Electric Corporate Research and

Development (GE/CRD), and the comparative testing was carried out by Rolls-Royce Corporation (Allison Advanced Development Company).

The thin-film etalon approach to surface pressure mapping investigated under this effort proved to be non-viable due to problems in achieving sufficient mechanical strength for the cap material(s) to achieve large overhang ratios, and due to problems in achieving a high signal-to-noise ratio (as a result of low cap reflectivity, high substrate reflectivity, and light scattering). None of these problems was successfully overcome during the course of this program. However, a "macro-etalon" was successfully demonstrated as a proof of concept of etalons as a pressure measurement technology. At the conclusion of this program, the only optical airfoil pressure mapping technology demonstrably capable of application in a turbine engine compressor and fan environment was pressure sensitive paint.

Two pressure sensitive paint formulations with a high amount of TiO₂, namely ruthenium bathophenanthroline complex ((Ru-Ph₂phen)₃²⁺) and (TfPP) FIB, were tested under this program. Both paint formulations displayed a stable, reproducible pressure-dependent luminance. The dynamic pressure response of the (TfPP) FIB formula with a high amount of TiO₂ displayed a 3-dB bandwidth of approximately 700 Hz. The bandwidth was taken to be the 3-dB bandwidth associated with a single-order system having a rise time defined by the 10%-to-90% rise time displayed by the paint under a positive going step pressure change. This 3-dB bandwidth is still approximately an order of magnitude less than the 6-kHz bandwidth goal set forth in the Propulsion Instrumentation Working Group (PIWG) surface pressure technology goals as a 2001 HCF exit criterion. The highest temperature to which the FIB paint was subjected was 99°C (210°F). At that temperature, the paint was still functioning. Although the upper temperature limit of this paint was not determined, it is assumed that it is below the upper temperature limit of 450°F specified in the 2001 HCF exit criteria, but that it is near the minimum useful goals specification of 300°F.

Participating Organizations: Rolls-Royce, General Electric Corporate Research & Development

Points of Contact:

Government

Ms. Kelly Navarra
U.S. Air Force, AFRL/PRTF
1950 Fifth Street, Bldg. 18D
Wright-Patterson AFB, OH 45433-7251
Phone: (937) 255-2734
Fax: (937) 255-2660
Email: kelly.navarra@wpafb.af.mil

Contractor

Mr. Thomas Bonsett
Rolls-Royce
Speed Code W03A, P.O. Box 420
Indianapolis, IN 46206-0420
Phone: (317) 230-3448
Fax: (317) 230-4246
Email: tbonsett@iquest.net

3.2.3 Validation of Paint/Optical Pressure Mapping *FY05*

An Advanced Turbine Engine Gas Generator (ATEGG) test will be conducted in fiscal year 2005. A change to the General Electric / Allison Advanced Development Company contract is currently being developed to accommodate this task.

Participating Organizations: Rolls-Royce, ISSI

Points of Contact:

Government

Ms. Kelly Navarra
U.S. Air Force, AFRL/PRTF
1950 Fifth Street, Bldg. 18D
Wright-Patterson AFB, OH 45433-7251
Phone: (937) 255-2734
Fax: (937) 255-2660
Email: kelly.navarra@wpafb.af.mil

Contractor

Mr. Thomas Bonsett
Rolls-Royce
Speed Code W03A, P.O. Box 420
Indianapolis, IN 46206-0420
Phone: (317) 230-3448
Fax: (317) 230-4246
Email: tbonsett@iquest.net

3.2.4 Wireless Telemetry *FY 00-02*

Recent Progress

An ultrasonic telemetry system is being developed by NASA Glenn Research Center, Army Research Laboratory, and Case Western Reserve University, for communication from an enclosed thick metal environment, such as a turbine engine, to an outside control room. Piezoelectric transducers are to be used to transmit and receive ultrasonic signals carrying data from sensors in environments that preclude conventional radio frequency (RF) and optical telemetry. A laboratory system has been designed, constructed, and evaluated at high frequency (100 kHz to 5 MHz), and a feasibility demonstration unit has been built and evaluated with single-cycle carrier pulse transmission.

Participating Organizations: NASA Glenn Research Center

Point of Contact:

Government

Dr. Jih-Fen Lei
NASA Glenn
Cleveland, OH
Phone: 216-433-3922
Fax: 216-433-8643
Email: jih-fen.lei@grc.nasa.gov

3.2.5 MEMS Pressure Sensor

FY 00-02

Recent Progress

A Silicon Carbide (SiC) based MEMS pressure sensor developed by NASA Glenn Research Center and Kulite Semiconductor Products was successfully tested on a gas turbine engine at Honeywell. The SiC pressure sensor was flush-mounted in the compressor discharge region of a Honeywell AS907 core engine. The sensor performed properly during an hour-long test, during which the sensor was subjected to temperatures as high as 520 °C.

The SiC pressure sensor was designed to specifications provided by the Propulsion Instrumentation Working Group (PIWG), the consortium of aircraft engine manufacturers and Government laboratories that arranged the engine test. This sensor fills a long-standing need of the aircraft engine companies for a high-temperature pressure sensor suitable for applications such as compressor surge mapping. Two technologies developed at NASA Glenn, a deep reactive ion etching (RIE) process for SiC, and a metallization system for high-temperature ohmic contacts to SiC, played critical roles in enabling the development of the sensor.

Participating Organizations: NASA Glenn Research Center

Point of Contact:

Government

Dr. Jih-Fen Lei

NASA Glenn

Cleveland, OH

Phone: 216-433-3922

Fax: 216-433-8643

Email: jih-fen.lei@grc.nasa.gov

3.2.6 AIN Sensors

FY 00-06

Background

The University of Dayton Research Institute performed a preliminary investigation of the use of piezoelectric aluminum nitride (AlN) sensors in environments and applications likely to be encountered in operating gas turbine engines. Research was concentrated in three areas: pressure sensing, strain measurement, and ultrasonic defect detection. Advances in the technology were made in each area.

Recent Progress

Pressure Sensing

In prior research, UDRI successfully used a piezoelectric AlN film to sense dynamic forces, using a charge amplifier for signal conditioning. Sensors based upon this principle are commonly used to sense force, acceleration, and pressure. The goal of this task was to demonstrate the use of the AlN as a dynamic pressure sensor. A first attempt using the application of hydrostatic air pressure was unsuccessful due to a lack of robustness in the experimental apparatus.

To provide an improved experiment, a pressure test stand was constructed. It consisted of a pressure chamber, a furnace, and a nitrogen gas pressure supply. Manually-operated valves applied or released pressure to the sensor in the heated pressure chamber. This arrangement allowed the application of pressure pulses to the sensor at various temperatures and pressures. Chamber oscillations occurred upon pressurization of the chamber, so only the pulses generated by releasing the pressure were used for testing.

A pressure sensor was designed that would work in both the pressure chamber and in a Kulite sensor port. Ceramic insulation and metal sealing surfaces were used throughout the sensor to allow elevated temperature operation. An AlN film on a tungsten carbide substrate was fixed in the sensor such that the sensor body formed the ground electrode and an insulated wire formed the positive electrode. An Endevco model #2735 charge amplifier converted electrical charges from the sensor into a voltage signal that could be recorded or viewed on an oscilloscope.

The prototype sensors showed sensitivity comparable to commercially available quartz-based piezoelectric pressure sensors at room temperature. The sensitivity decreased with temperature, and the signal became too small to be useful at approximately 400°C. This decrease in sensitivity is probably due to increased charge leakage around the edge of the AlN film. Improved performance and higher-temperature operation will be possible if this leakage can be reduced. One improvement will be to isolate the sensing element of the transducer from the fluid whose pressure is being measured. Increasing the gap between electrodes in the transducer will also help. Finally, evacuating the transducer or refilling it with a dielectric gas might be used to suppress charge leakage.

Two of the prototype sensors have been delivered to Honeywell Engines in Phoenix for testing in an actual engine. Dynamic pressures will be measured after the compressor but before the combustor in the engine. Data from this testing will be included in the final report for this project. Because the sensitivity of the sensor is not dependent on AlN film thickness or area, miniaturization of this sensor below its current size should be achievable for future work.

Strain Measurement

Surface acoustic waves (SAW) provide a sensitive means of monitoring surface strain in a component. UDRI has proposed depositing interdigital AlN transducers directly on components for the generation and reception of such waves. In this task, several attempts were made to deposit AlN films and machine them into interdigital transducers. Thin lines of the AlN had poor adhesion to the substrate, and the addition of a metal electrode on the film affected the laser machining process substantially. As a result, no working transducers were produced. However, the lessons learned will allow further progress, possibly by changing the machining process. In related work (not a part of this contract), an AlN film was successfully deposited on titanium metal, further indicating that SAW strain sensors may be possible on operational components.

Ultrasonic Defect Detection

Ultrasonic waves have historically been used for thickness measurement and defect detection. On-line engine health monitoring philosophies will require sensors that can survive and operate in high-temperature, harsh environments. AlN is a candidate for such sensors, but further research is required. This research was continued as a part of this project.

AlN films have a rough surface when produced. Polishing improves the strength of the ultrasonic signal from the film by providing uniform excitation and increasing the coherence of the generated pulse. According to theory, a surface roughness of ~1% of the wavelength of the ultrasonic energy will allow maximum energy transfer from a film. Experiments showed this to be the case, with dramatic increases initially and only slight gains at roughnesses below 1%. Substantial additional gains were realized from further polishing because it resulted in more uniform excitation. For some applications, polishing beyond 1% may not be necessary, but in others it will be required.

A second issue for AlN ultrasonic sensors is environmental protection. Research showed that protection from oxidation will probably be needed for operation above 700°C. The use of an inert metal as an outer electrode will probably provide this protection. The substrate material will also require protection in some cases. A ceramic coating was identified that will protect the tungsten carbide substrate from oxidation up to 900°C. For a permanently installed sensor, such a coating can also be used to protect the AlN film.

Finally, the coupling of ultrasonic energy at elevated temperatures is difficult. The use of a metal foil that softens at the temperature of interest is one solution to this problem. Another possible solution is to use a ceramic bond layer that would transmit the energy. The coating noted above was found to transmit ultrasonic energy, but poorly.

One target application for the ultrasonic sensor is to monitor the integrity of an environmental barrier coating on the inner surface of a SiC/SiC composite combustor with a sensor mounted on the outer surface. This material was found to have acceptable ultrasonic properties at room temperature. Surface finish of the part was also found to be an issue, as a polished surface is desired for maximum energy transfer. Experiments to evaluate the ultrasonic properties of the material at elevated temperatures were unsuccessful because efficient coupling was not achieved. However, further experimentation with metal film coupling will probably produce definitive results.

Conclusions

This project advanced AlN film technology toward use in the turbine engine environment. For pressure measurement, first-generation prototypes were constructed and successfully tested. One of

these prototypes will soon be tested in an operating engine. Some progress was made toward determining the parameters of devices necessary for strain measurement at elevated temperature. Parameters necessary for using the films as ultrasonic transducers were determined, including oxidation limits, protection methods, and required surface finish. SiC/SiC composite was found to be acceptable for the propagation of ultrasonic energy.

Participating Organizations: Air Force Research Laboratory, University of Dayton Research Institute

Points of Contact:

Government

Ms. Kelly Navarra
U.S. Air Force, AFRL/PRTF
1950 Fifth Street, Bldg. 18D
Wright-Patterson AFB, OH 45433-7251
Phone: (937) 255-2734
Fax: (937) 255-2660
Email: kelly.navarra@wpafb.af.mil

Contractor

Mr. James Sebastian
University of Dayton Research Institute
Dayton, OH
Email: sebastian@udri.udayton.edu

3.3 Improved Conventional Sensors

To date, prediction of aerodynamic forcing functions has been difficult or impossible due to lack of Computational Fluid Dynamics (CFD) fidelity, structural modeling accuracy, instrumentation effects, and insufficient characterization of instrumentation installation effects. The purpose of the projects described below is to improve the lifetime and performance of conventional sensors (eddy current/strain gages) for transition into engine health monitoring applications.

3.3.1 Non-Optical NSMS Sensor Development (Eddy Current) *FY 99-01*

Background

Incipient failure of rotor blades and disks can sometimes be anticipated by detecting a damage signature early. Hood Technology is exploring the possibility of reliably obtaining such signatures with a blade tip sensing system (Figs. 59 & 60). The system uses a few non-contacting blade detectors per rotor disk. Each detector generates an impulse at blade passage. Two pieces of information are then sent to a processing unit: (1) time of arrival and (2) blade tip clearance. Analysis of these signals allows detection of FOD, of blade resonances, and of rotor anomalies. Both types of information are indicative of incipient failure. Because the system utilizes a very limited suite of sensors and gathers information in a very efficient way, it has strong potential to evolve from a laboratory system to an on-board engine diagnostics unit.

Recent Progress

Hood Tech staff have used this technique during two Pratt & Whitney engine tests and in numerous lab tests, and have developed autonomous software to allow operation without human supervision. The system has been sold to two customers for laboratory use.

	<i>Long Range Goals</i>	<i>Current</i>
Foreign Object Damage (FOD)	Count and classify FOD events for each blade.	<u>Can be done:</u> All FOD events can be detected by impact transients of each blade. FOD classification is more difficult.
High Cycle Fatigue (HCF)	Monitor HCF damage accumulation.	<u>Can be done.</u> HCF damage accumulation can be estimated by monitoring FOD events and by counting vibratory stress cycles.
	Anticipate HCF failure.	<u>Maybe.</u> Shifts in resonance, amplitude, mode shape and damping are under investigation as reliable failure precursors.
Turbine Blade Creep	Monitor creep through long-term trend of turbine blade length.	<u>Can be done.</u> Long-term trend in tip clearance can be measured.
Bent blades	Detect bent blades.	<u>Can be done.</u> Bent blades are easy to detect, from time of arrival.
Rotor Burst	Anticipate rotor burst.	<u>Maybe.</u> Ideas for this exist. Feasibility not demonstrated.
Fully Autonomous	A fully autonomous system.	<u>Development required.</u> All current laboratory systems require much human intervention for data interpretation.

TABLE 3. Hood Technologies Blade Tip Sensing System Applications

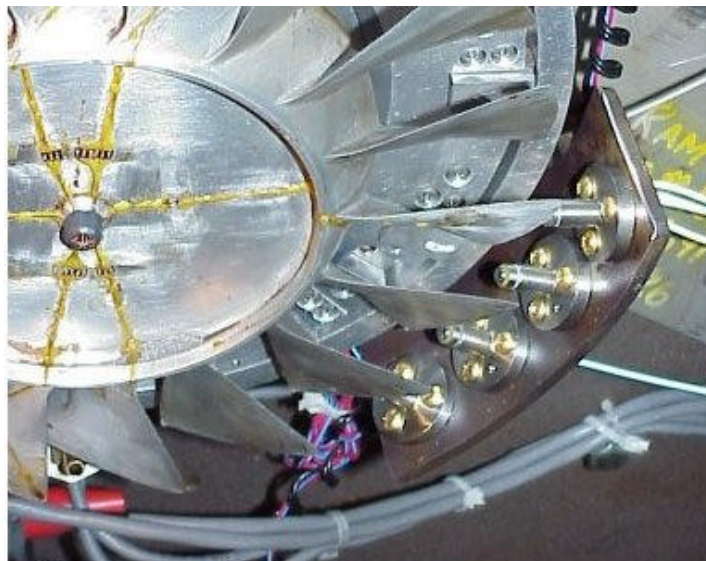

FIGURE 59. Four Capacitive Sensors Monitor Blade Vibration on a 12" Rotor at the Naval Post-Graduate School Spin Pit Facility in Monterey, California

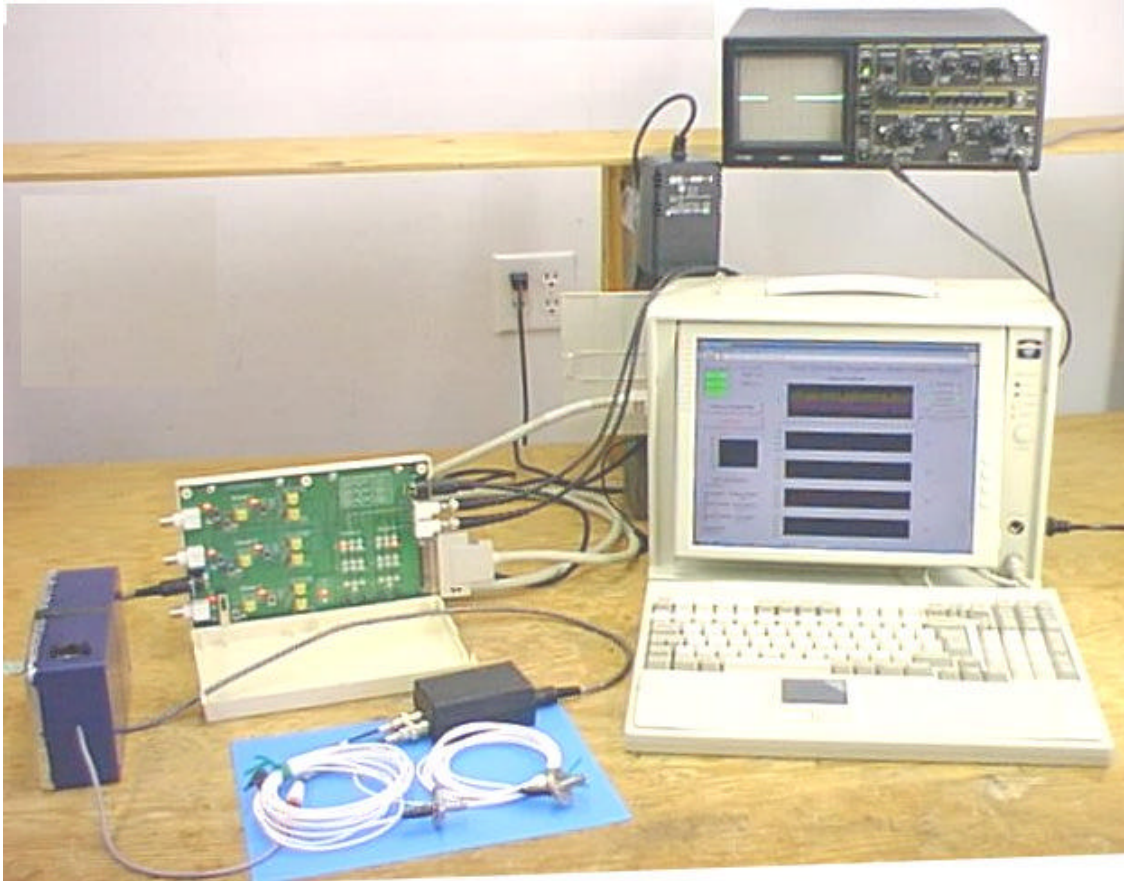

FIGURE 60. Hardware & Software to Monitor Rotor and Blade Dynamics Using Blade Time-of-Arrival and Tip Clearance

Participating Organizations: Pratt & Whitney

Points of Contact:

Government

Ms. Kelly Navarra
U.S. Air Force, AFRL/PRTF
1950 Fifth Street, Bldg. 18D
Wright-Patterson AFB, OH 45433-7251
Phone: (937) 255-2734
Fax: (937) 255-2660
Email: kelly.navarra@wpafb.af.mil

Contractor

Mr. Robert Morris
Pratt & Whitney
M/S 707-22, P.O. Box 109600
West Palm Beach, FL 33410
Phone: (561) 796-5981
Fax: (561) 796-7454
Email: morrisrj@pwfl.com

3.4 Development of Long-Life, Less-Intrusive Strain Gages

The following sections describe NASA's efforts to develop long-life, less-intrusive strain gages.

3.4.1 Advanced Thin-Film Dynamic Gages *FY 95-01*

Background

The objective of this program is to develop and utilize the already successful NASA PdCr static strain gages in a thin-film form for dynamic strain measurement. Thin-film sensors are fabricated directly onto the test surface using vapor deposition and lithography techniques. They do not require additional bonding agents such as adhesive or cements, and are in direct contact with the test surface. Thin-film sensors in general have a thickness on the order of a few micrometers (μm) and are much thinner than the commonly used sensor wires. They have fast response times (in milliseconds), add negligible mass to the test surface, and create minimal disturbance of the gas flow over the surface. Consequently, thin-film sensors have minimal impact on the thermal, strain, and vibration patterns that exist in the operating environment, and provide a minimally intrusive means of accurate measurement of surface parameters.

Recent Progress

During the past year, the PdCr thin-film strain gages were fabricated and dynamically evaluated on a nickel-base superalloy at NASA Glenn. The dynamic response of these gages was characterized in a newly-set-up shaker facility under ± 2000 microstrain, 1,100 Hz to 700C. The lifetime of this PdCr based thin-film gage was compared to the conventional foil strain gages at room temperature. Only two of the six commercial foil gages (33%) survived after only 3.5 minutes dwell at 1,100 Hz, while all four PdCr gages remained functional after a 50 minutes dwell exposure. The test at high temperature was postponed because the test bar cracked and broke; no gage delamination was observed. Meanwhile, NASA Glenn provided funding to Honeywell (AlliedSignal Engine) to apply nine thin-film strain gages, three per stage, on the stages 2, 3 and 4 gamma blades of a Pratt & Whitney engine XTC76/1 compressor. However, due to the surface imperfection of the compressor blades, which required additional time to redo the thin-film gages, Pratt & Whitney decided not to apply thin-film sensor technologies for validation. Honeywell is now seeking another gaging demonstration opportunity.

Participating Organizations: NASA Glenn Research Center, Honeywell Engines and Systems

Points of Contact:

Government

Dr. Jih-Fen Lei
NASA Glenn
Cleveland, OH
Phone: 216-433-3922
Fax: 216-433-8643
Email: jih-fen.lei@grc.nasa.gov

Contractor

Harvey Niska
Honeywell Engines and Systems
Phoenix, AZ
Phone: 602-231-7584
Fax: 602-231-2018
Email: h.niska@alliedsignal.com

3.4.2 Advanced High-Temperature Thin-Film Dynamic Gages *FY 96-01*

Background

The objective of this program is to develop advanced thin-film strain gages with increased temperature capability. This work is proceeding under a grant from the University of Rhode Island (URI), and is utilizing a ceramic sensing material, Indium Tin Oxide (ITO).

Recent Progress

During the past year, the characteristics of a high-temperature thin-film strain gage utilizing Indium Tin Oxide (ITO) continued. A reproducible piezoresistive response was measured with a drift rate as low as 0.0018%/hr at 1,450°C. The gage factor remained relatively constant from room temperature to 1,100°C, with a maximum gage factor of 21.8 at 1,190°C (2,170°F). The dynamic response and lifetimes of the gages were characterized in a shaker facility under ± 300 microstrain, 2,100 Hz, to $T=700^\circ\text{C}$. This ITO-based strain sensor failed after an 18-million-cycle test at room temperature, five thermal cycles to 1,100°C, and then 11 million cycles at 700°C. The failure mechanism was due to the detachment of lead wires from the thin-film sensor. The improvement of lead wire attachment techniques is being addressed.

Participating Organizations: NASA Glenn Research Center, University of Rhode Island

Points of Contact:

Government

Dr. Jih-Fen Lei
NASA Glenn
Cleveland, OH
Phone: 216-433-3922
Fax: 216-433-8643
Email: jih-fen.lei@grc.nasa.gov

Contractor

Prof. Otto Gregory
University of Rhode Island
Kingston, RI
Phone Number: 401-874-2085
Fax Number: 401-874-1180
Email: gregory@egr.uri.edu

3.5 Conclusion

The first end-to-end hardware checkout of the Generation 4 subsystems was successfully conducted in an electronics laboratory at Arnold Air Development Center (AEDC) in September 2000. Additionally, data files were successfully transferred from the BDSF to the Gen 4 Software System under development by AEDC. Generation 4 optical probes being procured under the ATEGG contract are in final assembly and will be available for installation into XTC67/1 for validation testing. Software efforts in 2000 were focused on coordination with developers of Generation 4 Front-End in defining the G4F-to-G4P interface requirements, and development of G4P algorithms/software. The Gen 5 effort, to convert deflection to stress, will use the SDRAC, which is being developed at AEDC. The G4P-to-SDRAC interface implementation is planned for fiscal year 2002. The BDSF processing hardware for future buildup of the AEDC G4F was procured. The Preliminary Design Review (PDR) was completed and software development is being documented under Government guidelines.

System development and integration will continue into fiscal 2001-02. The four basic algorithms (SWAT, SBA, Traveling Wave Analysis, and Single Degree of Freedom) are planned to be in place in fiscal year 2001, with completion in fiscal year 2002. Procurement of two 24-channel NSMS systems is underway, with fabrication and checkout to be completed in fiscal year 2002. Completion of the NSMS developmental effort in fiscal year 2002 depends on the readiness of the G4F design for reproduction. The status of the G4F will be determined after the final acceptance test results are completed and an evaluation of required improvements is assessed.

Over the past year, extensive work has been done to process the Pressure-Sensitive Paint (PSP) data obtained from last year's Compressor Research Facility (CRF) test. Many issues involving post-processing software have been resolved. NASA has participated in the PSP data evaluation and comparison to CFD. An ASME journal paper on the effort is now in the final editing stages.

A shock tube was used to measure the response time of the paints. The new Sol Gel-based PSP formulation shows response times of better than 1 kHz while maintaining excellent mechanical properties. The fast Pressure Sensitive Paint was then applied to a stator blade (wake generator) in the Compressor Aerodynamics Research Laboratory (CARL) at Wright Patterson Air Force Base. Data indicates that the PSP system respond to the pressure disturbance associated with the passage of the rotor blade (7150 Hz). An Advanced Turbine Engine Gas Generator (ATEGG) test is anticipated in fiscal year 2005.

4.0 COMPONENT ANALYSIS



BACKGROUND

The Component Analysis Action Team (Component Analysis AT) is responsible for fostering collaboration between individual HCF component analysis efforts, with the overall goal of combining with the Instrumentation and Forced Response ATs to better determine alternating stresses to within 20%. The Component Analysis AT provides technical coordination and communication between active participants involved in HCF component analysis technologies. Annual technical workshops have been organized and summaries of these workshops are disseminated to appropriate individuals and organizations. The Chair, Co-Chair, and selected Component Analysis AT members meet as required (estimated quarterly) to review technical activities, develop specific goals for component analysis projects, and coordinate with the TPT and IAP. The Chairman (or Co-Chair) of the Component Analysis AT keeps the TPT Secretary informed of AT activities on a frequent (at least monthly) basis. This AT includes members from government agencies, industry, and universities who are actively involved in component analysis technologies applicable to engine HCF. The team is to be multidisciplinary with representatives from multiple organizations representing several component technologies as appropriate. The actual membership of the AT may change in time as individuals assume different roles in related projects.

ACTION TEAM CHAIRS



Chair
Mr. Paul J. Zimmerman
Naval Air Systems Command
AIR 4.4.7.2 Bldg. 106
22195 Elmer Road, Unit #4
Patuxent River, MD 20670-1534
Phone: (301) 757-0500
Fax: (301) 757-0562
Email: ZimmermanPJ@navair.navy.mil



Co-Chair
Mr. Jeffrey M. Brown
U.S. Air Force, AFRL/PRTC
1950 Fifth Street, Bldg. 18D
Wright Patterson AFB, OH 45433-7251
Phone: (937) 255-2734
Fax: (937) 255-2660
Email: Jeffrey.Brown@wpafb.af.mil

INTRODUCTION

The following pages summarize the schedules, backgrounds, and recent progress of the current and planned projects managed by this action team.

Component Analysis Research Schedule

Product	FY95	FY96	FY97	FY98	FY99	FY00	FY01	FY02	FY03	FY04	FY05	FY06
4.1 Assessment of Turbine Engine Components				████████████████████								
4.2 Probabilistic Design for Turbine Engine Airfoils, Phase I					████████████████████							
4.3 Probabilistic Design of Turbine Engine Airfoils, Phase II								████████████████████				
4.4 Probabilistic Blade Design System				████████████████████								
4.5 Efficient Probabilistic Analysis Methods for Turbine Engine Components					████████████████████							
4.6 PREDICT								████████████████████				

4.1 Assessment of Turbine Engine Components

FY 98-01

Background

Activities on this program are focused on analytical models of the complex behavior encountered in turbine engine design, including improvements in both model physics and computational efficiency. For example, a task completed last year culminated in the development of techniques for detailed modeling of bolted connections based on the determination of effective joint properties using a detailed local analysis, which may be linear or nonlinear. An ongoing effort is aimed at providing tools for estimating errors in finite element natural frequency predictions.

Several analytical tasks are currently in progress on this program. Finite element and semi-analytical methods have been developed for the prediction of residual stresses induced by laser shock peening (LSP) under a variety of conditions; predictions of residual stresses in relatively thick sections show excellent agreement with residual stresses measured by x-ray diffraction. A related effort is in progress to explore the residual stress patterns induced by foreign object damage (FOD) on blade edges, and their effect on fatigue life. FOD damage also has been investigated in connection with the XTE-66/SE CAESAR engine; as part of this investigation, we have analyzed numerous FOD scenarios, developed an improved analytical/material model for evaluating FOD damage and potential failure, and performed impact experiments to prepare damaged nickel and titanium aluminide blade specimens for high cycle fatigue testing. An analytical investigation is also in progress to develop more efficient procedures for three-dimensional contact analysis of fretting and similar problems, based on substructuring techniques. Recently, UDRI began an effort to determine if Selective Laser Sintering (SLS) could be utilized as a cost-effective means to generate hardware for limited performance testing. If successful, SLS would allow more experimental validation earlier in the design cycle, which should result in performance improvements, reduced programmatic risks, and ultimately, improved design codes, because of the more abundant experimental data.

Recent Progress

The task dealing with LSP analysis has been completed, and a final report is in preparation. Figure 61 shows a comparison of residual stresses predicted using two methods developed on this program versus measured (x-ray diffraction) data. The agreement is quite good. These methods can be used in the design of more effective LSP processes, and for incorporating residual stress effects in part life estimates.

Simulations of the XTE-66/SE TiAl compressor blade performed as part of this program (Fig. 62) have clarified the role of foreign object damage in design using more brittle high-temperature materials, and have identified the need for improved models of nonlinear material response and failure. A preliminary version of such a model has been developed and is being tested currently. To investigate the influence of typical FOD events on high cycle fatigue of advanced materials, impact damage was inflicted on several TiAl and nickel compressor blades, which next will be tested under HCF loading conditions.

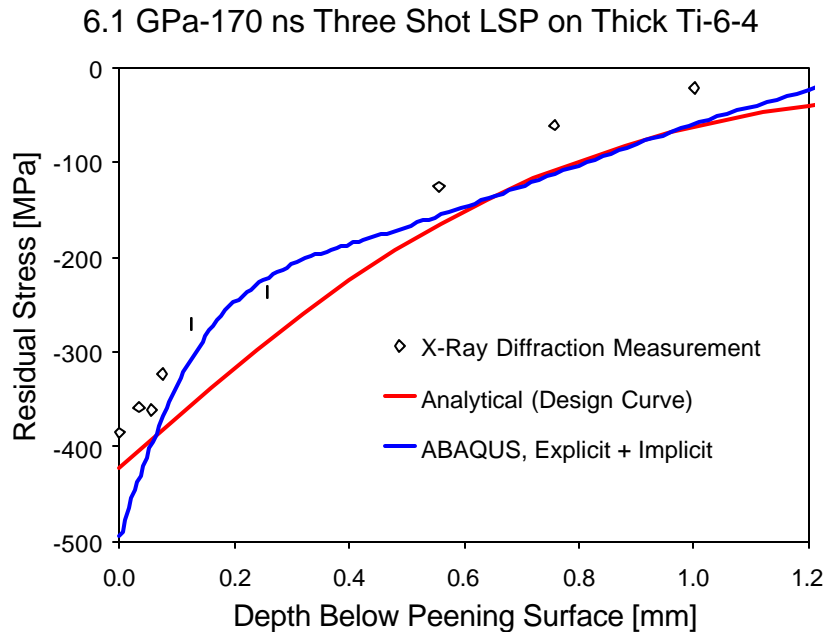

FIGURE 61. Analytical Prediction of Residual Stresses from LSP



FIGURE 62. Compressor Blade FOD Simulation

A relatively recent task on this program deals with improving the efficiency of three-dimensional contact analysis, as required in fretting fatigue and friction damping investigations, using substructured finite element models. The technique reduces the nonlinear problem to a relatively small system which can be solved many times faster than the complete model, but without omitting important details. Computational times observed with this method are very encouraging. Currently, an evaluation of the technique is in progress using a blade dovetail fretting problem as a model system.

Participating Organizations: University of Dayton Research Institute

Points of Contact:

Government

Mr. Jeffrey M. Brown
 U.S. Air Force, AFRL/PRTC
 1950 Fifth Street, Bldg. 18D
 Wright Patterson AFB, OH 45433-7251
 Phone: (937) 255-2734
 Fax: (937) 255-2660
 Email: Jeffrey.Brown@wpafb.af.mil

Contractor

Dr. Robert A. Brockman
 University of Dayton Research Institute
 300 College Park
 Dayton, OH 45469-0110
 Phone: (937) 229-3484
 Fax: (937) 229-4251
 Email: brockman@udri.udayton.edu

4.2 Probabilistic Design of Turbine Engine Airfoils, Phase I

FY 99-03

Background

The objective of this effort is to establish the best practices for HCF probabilistic risk assessment, life prediction, and design procedures. STI Technologies, Inc. is the prime contractor, but all major engine companies (P&W, GEAE, Allison, and Honeywell) are actively participating in the contract.

The proposed probabilistic methods and approaches are intended to improve the overall engine design system. Probabilistic design methods will assist the turbine engine industry and responsible government agencies by reducing HCF-related costs and by improving safety by: (1) providing a better engine design “out of box,” (2) providing a methodology to develop bench, rig, and engine testing plans that identify and characterize potential HCF problems, (3) providing a methodology to track HCF “life” in the field, and (4) enabling the PPGM to schedule regular HCF maintenance intervals and to accurately assess future needs for spare parts. Probabilistic models will be developed that incorporate refinements to the design process of gas turbine fan blades through the use of advanced stochastic modeling of the HCF-related phenomena, with a special focus on blade forced response, including unsteady aero-forcing, damping and flutter, mistuning, manufacturing effects, and other critical aspects. Finally, an integrated probabilistic HCF prediction system capable of incorporating the rapid technological developments and new information from test and field data will be implemented.

These best practices will: (1) significantly improve the fundamental engineering process for interpreting the complex, random phenomena involved in blade design, (2) develop more efficient tools for probabilistic modeling using advanced stochastic concepts and models, (3) apply probabilistic approaches to evaluate existing or fielded designs, (4) develop methods for updating probabilistic assessments with information from both experimental and analytical data sources, (5) identify requirements for blade and specimen data and conduct testing where appropriate, and (6) identify requirements for component, rig, and engine testing.

Recent Progress

An initial contract with STI Technologies was awarded in May 1999. On-going efforts will identify the best practices related to the identification of the governing HCF parameters and define their associated uncertainties. Significant effort was invested in stochastic modeling of different important aspects such as mistuning, random fatigue limit, and manufacturing geometric deviations and their effects on blade vibration modes. STI has completed a comprehensive study on Airfoil Thickness Spatial Stochastic Variability using multiple statistical measurement datasets on Pratt & Whitney (P&W) and General Electric (GE) airfoils. P&W and GE have investigated key aspects of HCF stochastic modeling, such as the probabilistic evaluation of mistuning effects and statistical fatigue limit. The final report on this first task will address the governing HCF parameters and their statistical modeling. The report will include specific input from all engine companies and is due in February 2001.

The second major task is to develop a detailed approach to the stochastic modeling of blade forced response that considers all delicate aspects of the evaluation of unsteady aero-forcing, damping, and blade vibration, including aero and structural mistuning effects.

A flowchart depicting the probabilistic HCF prediction process (Fig. 63) is shown below.

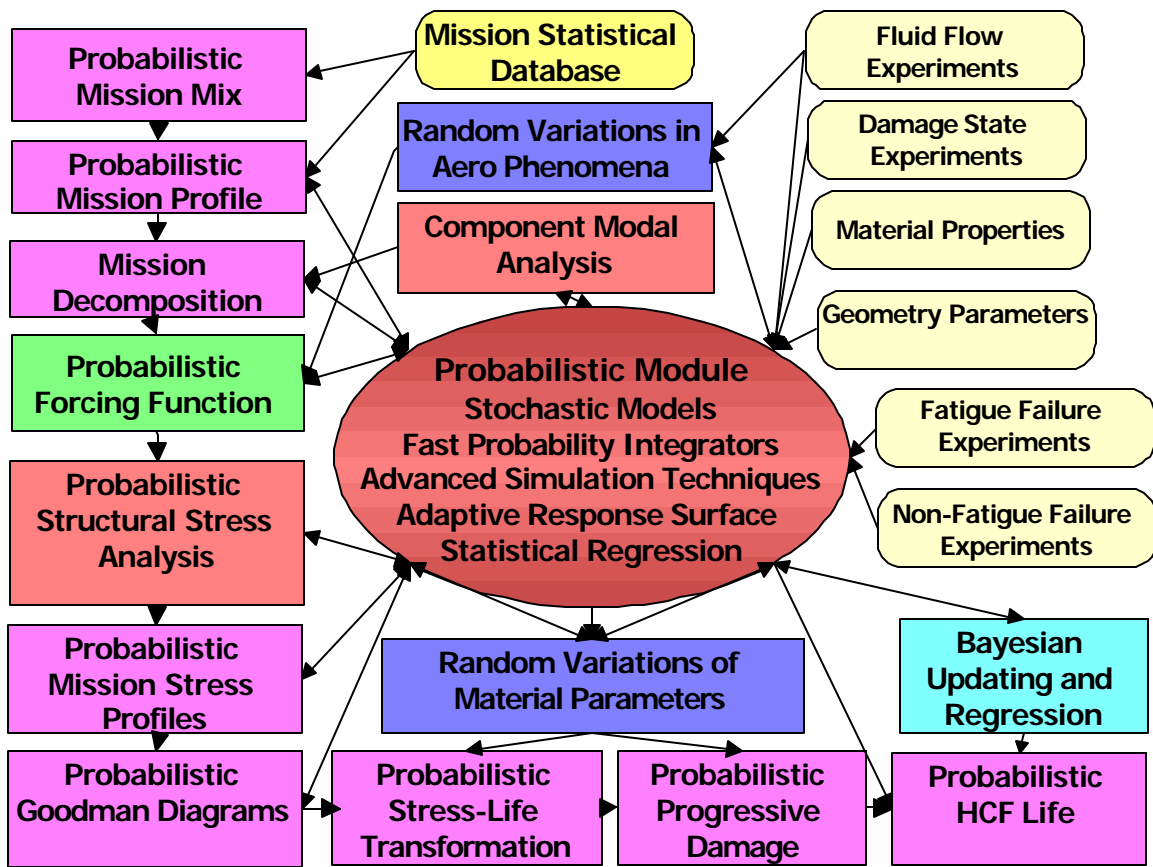

FIGURE 63. Probabilistic HCF Prediction Flowchart

Participating Organizations: STI Technologies, General Electric, Pratt & Whitney, Allison Advanced Development Co., GE Aircraft Engines, Honeywell Engines and Systems, Virginia Tech.

Points of Contact:

Government

Mr. Daniel Thomson
 U.S. Air Force, AFRL/PRTC
 1950 Fifth Street, Bldg. 18D
 Wright Patterson AFB, OH 45433-7251
 Phone: (937) 255-2081
 Fax: (937) 255-2660
 Email: Daniel.Thomson@wpafb.af.mil

Contractor

Mr. Ken Lally
 STI Technologies, Inc.
 1800 Brighton-Henrietta Town Line Rd.
 Rochester, NY 14623-2572
 Phone: (716) 424-2010
 Fax: (716) 272-7201
 Email: klally@sti-tech.com

4.3 Probabilistic Design of Turbine Engine Airfoils, Phase II

FY 01-05

Background

Phase II will make any required improvements the probabilistic forced response approaches developed in Phase I, enhance the probabilistic material modeling, and work towards validating probabilistic predictions and designs.

Recent Progress

Discussions with the engine community on the plans for Phase II have taken place.

Participating Organizations: Pratt & Whitney, GE Aircraft Engines, Honeywell, AADC

Points of Contact:

Government

Mr. Dan Thomson
U.S. Air Force, AFRL/PRTC
1950 Fifth Street, Bldg. 18D
Wright Patterson AFB, OH
45433-7251
Phone: (937) 255-2081
Fax: (937) 255-2660
Email: daniel.thomson@wpafb.af.mil

Contractor

TBD

4.4 Probabilistic Blade Design System

FY 98-01

Background

Probabilistic analysis capabilities are being investigated in the areas of response variability due to blade mistuning, fracture screening, and response variability due to manufacturing geometry variation. Application of these techniques to several blades will provide guidance for the incorporation of such capability into a mainstream blade design system.

Recent Progress

Investigation of blade-to-blade response variability due to mistuning continued using the REDUCE computer code developed at the University of Michigan. Two military fan blades were used in this study: one that has exhibited a substantial amount of response variation and another that has shown low variability. Analysis showed that REDUCE was able to predict the level of variation of blade maximum amplitudes relatively well but was not able to accurately predict the response of individual blades. It provided correct trend information to differentiate rotors with the potential for relatively higher or lower blade-to-blade variation. This work indicates that REDUCE provides worthwhile guidance and insight in predicting potential harmful blade-to-blade response variation.

Initial studies were also begun to assess a new version of the code, Turbo-REDUCE. In order to promote its future integration into a standard design system, pre-processing routines were developed to create Turbo-REDUCE input data from existing bladed disk or blisk models. Final implementation depends on enhancements to improve the overall utility of Turbo-REDUCE.

Fracture Screening to consider the effects of surface damage due to foreign object damage (FOD) has been worked using the Probabilistic Design Analysis System (PDAS) analysis environment, which was developed under the Probabilistic Rotor Design System (PRDS) contract. The basic infrastructure developed for PRDS has been extended for blade applications to assess the probability of exceeding crack growth threshold using probabilistic fracture mechanics with the capability of considering distributions of material data, leading edge (LE) damage, strain distribution, and amplitude variability. PDAS was used to link several computational modules to determine the overall failure probability of a front stage military fan. Static and modal finite element stress solutions were developed to consider airfoil geometric variations, blade-to-blade variability in rotor builds was predicted using REDUCE, and probabilistic fracture mechanics was used to predict the impact of randomly placed surface defects. This aspect of the study successfully demonstrated the mechanics of linking together the various modules. However, there is uncertainty as to which fracture mechanics modeling and damage distributions should be applied. Additionally, reliable predictions of absolute forced response levels are inherently difficult. These aspects combine to yield failure probabilities having less certainty than the prior disk work.

The ability to simulate response variability due to manufacturing has also been studied through adaptation of a conventional design/analysis toolkit used routinely for deterministic blade finite element analysis. Airfoil manufacturing inspection data from a military fan were analyzed to determine the fundamental geometric variations exhibited by the manufacturing process. These patterns were characterized by a reduced set of "manufacturing modes" consisting of correlations of traditional airfoil design parameters. The design/analysis toolkit was adapted to apply such correlated variables in response simulations. The toolkit was further extended to provide direct access to

probabilistic analysis services including Design of Experiments, Response Surface determination, and Monte Carlo simulation. Application of the tool to simulate modal response variation of a population of fan blades constructed according to the patterns of variation exhibited by the manufacturing variations yielded reasonable predictions of frequency variation that were consistent with typical design experience.

Participating Organizations: GE Aircraft Engines

Points of Contact:

Government

Mr. Jeffrey M. Brown
U.S. Air Force, AFRL/PRTC
1950 Fifth Street, Bldg. 18D
Wright Patterson AFB, OH 45433-7251
Phone: (937) 255-2734
Fax: (937) 255-2660
Email: Jeffrey.Brown@wpafb.af.mil

Contractor

Mr. Bill McAllister
GE Aircraft Engines
1 Neumann Way
Mail Drop A405
Cincinnati, OH 45215
Phone: (513) 243-3337
Fax: (513) 243-1343
Email: Bill.McAllister@ae.ge.com

4.5 Efficient Probabilistic Analysis Methods for Turbine Engine Components

FY 99-01

Background

Development of efficient and accurate methods for the reliability analysis of large-scale engine component models is the main goal of the project. For practical engine components, there are potentially dozens of uncertain variables, and the designers need to use robust techniques that can accurately predict the failure probability with a minimum number of simulations. Under this research effort, methods are being developed that use high-quality function approximations to reduce the computational cost of simulations. The simulations are typically carried out using finite element methods and computational fluid dynamics procedures. The project team developed methods based on Fast Fourier Transformation (FFT) techniques for accurately predicting the failure probability for highly nonlinear limit-states and non-normal distributions. To validate the concepts, several highly nonlinear analytical functions and structures modeled with truss and plate members were considered with normal, log-normal, and Weibull distributions. The results obtained using FFT were compared with the Monte Carlo simulations.

Recent Progress

Currently, emphasis is being placed on instances involving multiple failure modes, such as the uncertain natural frequencies and critical stresses. In these cases, the formulation needs to consider the system reliability instead of just the individual failure mode. We are developing techniques based on multi-point function approximations to construct a representation for the physical behavior of multiple functions. Once a representative model is developed, the designers will be able to use a Monte Carlo simulation on this analytical representation and compute the system failure probability. This work is under progress, and will be demonstrated on turbine engine components. A schematic of airfoil stochastic analysis is shown in Figure 64.

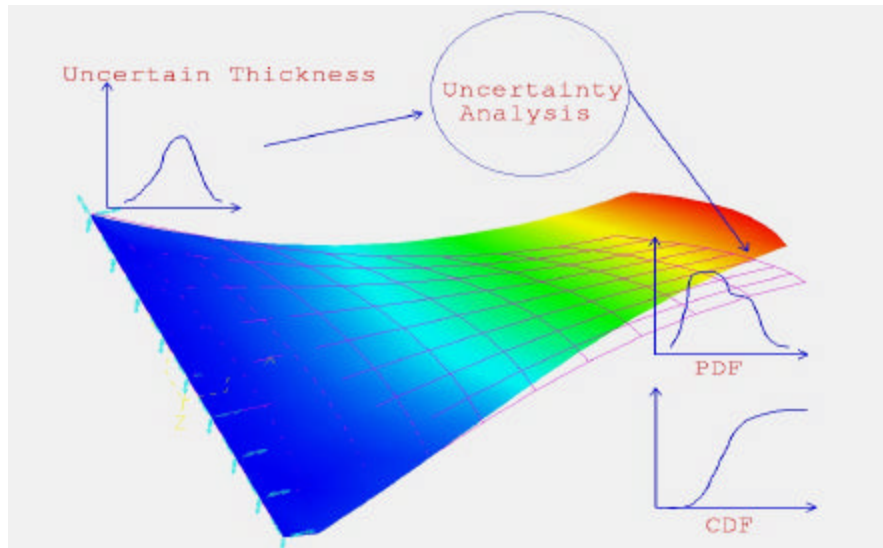

FIGURE 64. Airfoil Stochastic Analysis

Participating Organizations: Wright State University

Points of Contact:

Government

Mr. Charles Cross
 U.S. Air Force, AFRL/PRTC
 1950 Fifth Street, Bldg. 18D
 Wright Patterson AFB, OH 45433-7251
 Phone: (937) 256-5530
 Fax: (937) 255-2660
 Email: charles.cross@wpafb.af.mil

Contractor

Dr. Ramana Grandhi
 Wright State University
 3640 Colonel Glenn Hwy
 Dayton, OH 45435-0001
 Phone: (937) 775-5090
 Fax: (937) 775-5147
 Email: rgrandhi@cs.wright.edu

4.6 PREDICT

FY 01-03

Background

PREDICT is a process that assesses a component's failure probability throughout its design, test, and field experience, and has that been used with great success in the nuclear and manufacturing industry. The process creates the framework for the implementation of the probabilistic design system. PREDICT combines physics-based distributional models of critical contributors into model for overall blade HCF failure probability estimation. The process also guides the development of initial design parameter assessments that capture expert opinion and similarity to previous designs in structured manner to remove bias.

Recent Progress

Funding for this effort was recently acquired through NASA and will be undertaken shortly.

Participating Organizations: Pratt & Whitney, GE Aircraft Engines, Honeywell, AADC, LANL, NASA

Points of Contact:

Government

Mr. Jeff Brown
U.S. Air Force, AFRL/PRTC
1950 Fifth Street, Bldg. 18D
Wright Patterson AFB, OH 45433-7251
Phone: (937) 255-2734
Fax: (937) 255-2660
Email: jeffrey.brown@wpafb.af.mil

Contractor

Dr. Jane Booker, Statistician
Statistical Sciences Group, D-1
Los Alamos National Laboratory
MS F600
Los Alamos, NM 87545
Phone: 505-667-1479
Fax: 505-667-4470
Email: jmb@lanl.gov

4.7 Conclusion

The Component Analysis Action Team continued the government/industry/university team activities to develop an HCF probabilistic blade design system. Progress was made in the areas of LSP residual stress distribution with respect to depth, spatial stochastic modeling of blade thickness, random fatigue limits, upper tail distribution modeling, and multipoint functional approximations. A major agreement was reached to validate the Los Alamos National Laboratory's "PREDICT" tool. This task will demonstrate the ability to integrate empirical data with expert opinions to create a knowledge base for determining system reliability with confidence bounds. The demonstration will be performed in concert with the Forced Response Action Team over the next two years. NASA and industry are providing funding.

5.0 FORCED RESPONSE PREDICTION



BACKGROUND

The responsibility of the Forced Response Prediction Action Team (FRAT) is to foster collaboration between individual HCF forced response efforts and the Instrumentation and Component Analysis ATs in order to determine alternating stresses to within 20%. The Forced Response AT provides a means for technical coordination and communication between active participants involved in HCF unsteady aerodynamics and blade response technologies. Annual technical workshops have been organized and workshop summaries are disseminated to appropriate individuals and organizations. The Chair, Co-Chair, and selected Forced Response AT members meet as required to review technical activities, develop specific goals for forced response programs, and coordinate with the TPT and IAP. The Chairman (or Co-Chair) of the Forced Response AT keeps the TPT Secretary informed of AT activities on a frequent basis. This AT includes members from government agencies, industry, and universities who are actively involved in forced response technologies applicable to engine HCF. The team is to be multidisciplinary with representatives from multiple organizations representing several component technologies as appropriate.

ACTION TEAM CHAIRS



Chair
Dr. Charles J Cross
U.S. Air Force, AFRL/PRTC
1950 Fifth Street, Bldg. 18D
Wright Patterson AFB, OH 45433-7251
Phone: (937) 656-5530
Fax: (937) 656-5532
Email: charles.cross@wpafb.af.mil



Co-Chair
Mr. George Stefko
NASA Glenn Research Center
Mail Stop 49-8
21000 Brookpark Road
Cleveland, OH 44135-3191
Phone: (216) 433-3920
Fax: (216) 977-7051
Email: stefko@lerc.nasa.gov



Co-Chair
1Lt Chris Blackwell
U.S. Air Force, AFRL/PRTF
1950 Fifth Street, Bldg. 18D
Wright Patterson AFB, OH 45433-7251
Phone: (937) 255-4738
Email: chris.blackwell@wpafb.af.mil

INTRODUCTION

The following pages summarize the schedules, descriptions, and progress of the current and planned projects managed by this action team.

Forced Response Research Schedule

Product	FY95	FY96	FY97	FY98	FY99	FY00	FY01	FY02	FY03	FY04	FY05	FY06
5.1 Development of Physical Understanding and Models												
5.1.1 Development of TURBO-AE		████████████████████										
5.1.2 Nonlinear Modeling of Stall/Flutter			██									
5.1.3 Forced Response: Mistuned Bladed Disk (REDUCE Code)	██████████											
5.1.4 Design Guidelines for Mistuned Bladed Disk (REDUCE Code)		██										
5.1.5 Tip Modes in Low-Aspect-Ratio Blading	██████████											
5.1.6 Sensitivity Analysis of Coupled Aerodynamic/Structural Behavior of Blade Rows		██										
5.1.7 Dynamic Analysis & Design of Shroud Contact (BDAMPER Code)	██											
5.1.8 Friction Damping in Bladed Disks			██									

Forced Response Research Schedule

Product	FY95	FY96	FY97	FY98	FY99	FY00	FY01	FY02	FY03	FY04	FY05	FY06
5.2 Acquisition of Experimental Data												
5.2.1 High Mach Forcing Functions	█	█										
5.2.2 Forward Swept Blade Aeromechanics	█	█										
5.2.3 Oscillating Cascade Rig	████████████████████	████████████████████	████████████████████	████████████████████	████████████████████	████████████████████	████████████████████	████████████████████				
5.2.4 F109 Unsteady Stator Loading	████████████████████	████████████████████	████████████████████	████████████████████	████████████████████	████████████████████	████████████████████	████████████████████				
5.2.5 Fluid-Structure Interaction		████████████████████	████████████████████	████████████████████	████████████████████	████████████████████	████████████████████	████████████████████				
5.2.6 Experimental Study of Forced Response in Turbine			████████████████████	████████████████████	████████████████████	████████████████████	████████████████████					

Forced Response Research Schedule

Product	FY95	FY96	FY97	FY98	FY99	FY00	FY01	FY02	FY03	FY04	FY05	FY06
<p>5.3 Validation of Analytical Models</p> <p style="margin-left: 20px;">5.3.1 Evaluation of Current State-of-the-Art Unsteady Aerodynamic Models for the Prediction of Flutter & Forced Vibration Response</p> <p style="margin-left: 20px;">5.3.2 Evaluation of State-of-the-Art Aerodynamic Models</p> <p style="margin-left: 20px;">5.3.3 Forced Response Prediction Systems (Fans)</p> <p style="margin-left: 20px;">5.3.4 Aeromechanical Design System Validation</p> <p>5.4 New Efforts</p>			■				■					

5.1 Development of Physical Understanding and Models

Predicting forced response is difficult due to the lack of Computational Fluid Dynamics (CFD) fidelity and structural modeling accuracy. The purpose of the following projects is to develop the necessary modules for improved forced response prediction

5.1.1 Development of TURBO-AE *FY 96-99*

Background

The TURBO-AE Propulsion Aeroelasticity code is based on a three-dimensional unsteady aerodynamic Euler/Navier-Stokes turbomachinery code called TURBO. The structural dynamics model of the blade in the TURBO-AE code is based on a normal mode representation. In the Flutter version of the TURBO-AE code, a work-per-cycle approach is used to determine flutter stability.

Final Results

The development of the Flutter version of the TURBO-AE code has been completed, and validation by industry is ongoing. The development of the Forced Response version of the TURBO-AE code has started. Future planned activities that have not yet been funded include multistage analyses and new turbulence models. Future updates are reported in section 5.1.6, "Development of Aeroelastic Capability for the TURBO Code."

Participating Organizations: NASA Glenn

Point of Contact:

Government

Oral Mehmed
NASA Glenn Research Center
NASA Glenn Research Park
21000 Brookpark Rd., M/S 49-8
Cleveland, OH 44135-3191
Phone: (216) 433-6036
Fax: (216) 977-7051
Email: oral.mehmed@lerc.nasa.gov

5.1.2 Nonlinear Modeling of Stall/Flutter

FY 97-01

Background

The objective of this project is to investigate the use of reduced-order modeling (ROM) techniques to simulate linear and nonlinear stall flutter in cascades. Research will be conducted in three main areas: (1) the development of a time-domain, linearized Navier-Stokes analysis; (2) the development of an efficient eigenmode extraction code for large systems of equations; and (3) the development of reduced-order modeling techniques to model nonlinear unsteady flows, especially phenomena such as hard flutter boundaries and limit cycle behavior.

Recent Progress

Research has been conducted in two main areas: (1) the use of proper orthogonal decomposition (POD) techniques, and (2) the use of a novel harmonic balance technique for computing periodic but nonlinear unsteady flows in turbomachinery. Of these two techniques, the harmonic balance technique has proven to be the most useful for turbomachinery applications. Using this approach, the unsteady flow is assumed to be composed of harmonics of the excitation frequency—blade-passing frequency in the case of wake/rotor interaction; blade vibratory frequency in the case of flutter. Borrowing from the structural dynamics community, we then use the harmonic balance technique to write a set of coupled partial differential equations for the unknown flow solution at each harmonic. Finally, after introducing a pseudo-time term into the harmonic balance equations so that they may be solved by time marching, these equations are solved using conventional CFD techniques.

The method has a number of distinct advantages over the more conventional time-domain solutions. First, because the solutions are computed in the frequency domain, the time-marching algorithm is only used to converge the solution to steady state. Thus, acceleration techniques, including pseudo-time time marching with multiple-grid acceleration, can be used. Second, complex periodicity conditions may be applied for each harmonic, so that the computational domain may be reduced to a single blade passage. Finally, for many applications where "engineering accuracy" is required, the harmonic balance series can be truncated to just a few harmonics. The result is that the present method is potentially two orders-of-magnitude faster than conventional time-marching methods. Recently, the method has been applied to the Navier-Stokes equations with turbulence models. We have been able to predict both the onset of flutter and limit cycle behavior in a front stage compressor.

Participating Organizations: GUIde*, Air Force Research Laboratory (AFRL), NASA

() About GUIde: The GUIde Consortium was formed in 1991 when a number of companies joined with Carnegie Mellon University and Purdue University to form a partnership that would result in improved technology for understanding the problem of forced response in turbine engines. The "GUIde" acronym stands for "Government, Universities, and Industry" working together for a specific goal. The consortium is a precursor to the current national HCF program. The consortium consists of members from the US Air Force (Air Force Research Laboratory (AFRL) and the Air Force Academy), NASA, all four major engine manufacturers (GE, Pratt & Whitney, Allison and Honeywell Engines and Systems) and academia (Ohio State, University of California at Davis, Purdue, Carnegie Mellon, University of Michigan, Duke, and Notre Dame). Together, the consortium works to address shortfalls in alternating stress prediction capability with the academic and industrial members developing or validating new codes funded by the government and industry. Some of GUIde's early codes are currently being integrated into the design systems of the engine manufacturers.*

Points of Contact:

Government

Dr. Antole Kurkov
NASA Glenn Research Center
NASA Glenn Research Park
21000 Brookpark Rd., M/S 49-8
Cleveland, OH 44135-3191
Phone: (216) 433-5695
Fax: (216) 977-7051
Email: kurkov@lerc.nasa.gov

Contractor

Dr. Kenneth C. Hall
Duke University
Dept. of Mechanical Engineering & Materials Science
School of Engineering
P.O. Box 90300
Duke University
Durham, NC 27708-0300
Phone: (919) 660-5328
Fax: (919) 660-8963
Email: hall@euler.egr.duke.edu

**5.1.3 Forced Response: Mistuned Bladed Disk (REDUCE Code)
FY 92-96**

Background

Blade mistuning is the small, random, blade-to-blade variation in geometric and material properties that is unavoidable in bladed disks due to manufacturing tolerances and in-operation wear. Mistuning can lead to localization phenomena in which certain blades vibrate with higher amplitudes than other blades.

Final Results

Under this effort, a reduced-order modeling technique for mistuned bladed disks was developed. The resulting code, REDUCE, can calculate natural frequencies and modeshapes for a tuned case and for a prescribed mistuning pattern. REDUCE allows the user to obtain a frequency sweep output for the maximum blade response amplitude or for all blades. A Monte Carlo analysis is performed to determine the blade response amplitude and deviations. Pre- and post-processing capabilities allow for use of NASTRAN and ANSYS files. The REDUCE code version 1.0 has been transitioned to the industrial GUIde members.

Participating Organizations: GUIde

Points of Contact:

Government

Dr. Charles Cross
U.S. Air Force, AFRL/PRTC
1950 Fifth St, Bldg. 18D
Wright-Patterson AFB, OH 45433-7251
Phone: (937) 656-5530
Fax: (937) 656-5532
Email: charles.cross@wpafb.af.mil

Contractor

Dr. Christophe Pierre
University of Michigan
2250 G. G. Brown Bldg.
2350 Hayward Street
Department of Mechanical Engineering
The University of Michigan
Ann Arbor, MI 48109-2125
Phone: (734) 936-0401
Fax: (734) 647-3170
Email: pierre@umich.edu

5.1.4 Design Guidelines for Mistuned Bladed Disks (REDUCE Code)

FY 96-01

Background

The objective of this project is to develop a program for analysis and design of mistuned bladed disks based on REDUCE (first developed under GUIde I, with an updated version released each year).

Version 2.2 of REDUCE has been released to GUIde members. New features in REDUCE 2.2 include an enhanced capability for fine-tuning the reduced order model to match finite element model natural frequencies, the ability to input a complex forcing vector to capture local phase differences in the applied blade forces, a new capability for outputting/inputting the reduced order model to/from a single file, and improved support for post-processing the displacements and stresses in finite element coordinates.

Recent Progress

An updated Version 3.0 of REDUCE is in preparation. The main improvement is that the code has been made compatible with the Fortran compilers used on Silicon Graphics and IBM UNIX workstations. In fact, the beta version of REDUCE 3.0 has been compiled successfully on all major UNIX platforms, on Linux, and on Windows-based PCs. In addition, a more powerful, accurate, and efficient reduced order modeling technique has recently been developed. Based on this method, a new code called Turbo-Reduce has been written. The first version, Turbo-Reduce 2000, has been delivered to the members of the GUIde Consortium. In the near term, both codes will continue to be supported, since each has unique strengths: Turbo-Reduce has superior accuracy and efficiency, but currently REDUCE can handle larger finite element models and includes an option for modeling shrouded rotors. Finally, an experimental investigation has been initiated to generate validation data for mistuned and intentionally mistuned systems. Modifications and improvements will then be made to the REDUCE and Turbo-Reduce codes based on these findings.

Participating Organizations: GUIde

Points of Contact:

Government

Dr. Charles Cross
U.S. Air Force, AFRL/PRTC
1950 Fifth Street, Bldg. 18D
Wright-Patterson AFB, OH 45433-7253
Phone: (937) 656-5530
Fax: (937) 656-5532
Email: charles.cross@wpafb.af.mil

Contractor

Dr. Christophe Pierre
University of Michigan
2250 G. G. Brown Bldg.
2350 Hayward Street
Department of Mechanical Engineering
The University of Michigan
Ann Arbor, MI 48109-2125
Phone: (734) 936-0401
Fax: (734) 647-7303
Email: pierre@umich.edu

5.1.5 Tip Modes in Low-Aspect-Ratio Blading

FY 95-96

Background

The objective of this project was to develop a basic understanding of sources of variability in high-frequency motion in low-aspect ratio blades, and to develop codes based on this research. The two thrusts of the research were: (1) to understand the effect of taper angle and bluntness of the leading edge of the airfoil on the vibratory response of high-frequency tip modes, and (2) to develop an understanding of the manner in which closely-spaced modes interact to produce highly variable response.

Final Results

For the first thrust, using a tapered beam as a first-ordered approximation for a low-aspect ratio blade, it was determined that the magnitude and location of maximum stress were functions of the truncation factor. For small truncation factors, the response of a high-frequency mode was extremely sensitive to variations in the tip thickness. For the second thrust, for an airfoil with two modes of nearly equal frequency, the modes are highly sensitive to minor variations in blade geometry. Codes developed under this effort have been transitioned to GUIde members.

Participating Organizations: GUIde

Point of Contact:

Government

Dr. Charles Cross
U.S. Air Force, AFRL/PRTC
1950 Fifth St, Bldg. 18D
Wright-Patterson AFB, OH 45433-7251
Phone: (937) 656-5530
Fax: (937) 656-5532
Email: charles.cross@wpafb.af.mil

5.1.6 Development of Aeroelastic Capability for the TURBO Code

FY 96-02

Background

TURBO is a three-dimensional unsteady aerodynamic Navier-Stokes turbomachinery code for propulsion applications. Mississippi State University developed the TURBO code under a grant from Glenn Research Center. For aeroelastic calculations with TURBO, the structural dynamics model of the blade is based on a normal mode representation. For flutter calculations, a pre-processor is used to interpolate modal displacements onto the TURBO grid and to generate the deformed grid. Then, a prescribed harmonic blade vibration with a work-per-cycle calculation is used to determine flutter stability. For forced response calculations with TURBO, the aerodynamic interaction between adjacent blade rows is modeled either as (1) a rotor-stator interaction with multiple passages per blade row, (2) a rotor-stator interaction with phase-lag boundary conditions which requires modeling only one passage per blade row, or (3) a wake-blade interaction with the influence of the upstream row represented as an unsteady inlet excitation.

Recent Progress

Further verification and validation of the aeroelastic analysis capability has been done. The aeroelastic capability has been extended to the most recent version of the TURBO code v4.2. The improved capabilities thus include simplified name list inputs, a k-epsilon two-equation turbulence model, and real gas effects. Also, initial work has been done towards the extension of TURBO to multistage aeroelastic analysis and to analysis of centrifugal machines.

Participating Organizations: NASA Glenn

Points of Contact:

Government

Oral Mehmed
NASA Glenn Research Center MS 49-8
21000 Brookpark Road
Cleveland, OH 45135-3191
Phone: (216) 433-6036
Fax: (216) 977-7051
Email: Oral.Mehmed@grc.nasa.gov

Contractor

Dr. Milind Bakhle and Dr. Rakesh Srivastava
Organization: University of Toledo
Address: NASA Glenn Research Center MS 49-8
21000 Brookpark Road
Cleveland, OH 45135-3191
Phone: (216) 433-6037 (Dr. Bakhle)
(216) 433-6045 (Dr. Srivastava)
Fax: (216) 977-7051 (Both)
Email: Milind.A.Bakhle@grc.nasa.gov
Rakesh.Srivastava@grc.nasa.gov

5.1.7 Dynamic Analysis & Design of Shroud Contact

FY 92-01

Background

The objective of this project is to develop a program to predict blade vibration for rotors having shrouds and/or platform dampers (friction dampers). The completed GUIde I effort was instrumental in the development of BDAMPER, which facilitates analysis of blade-to-ground dampers, blade-to-blade dampers, shroud contact interfaces, and wedge dampers. The GUIde II effort focuses on the stick-slip transition for elliptical motion in the shroud contact plane.

Recent Progress

Under the GUIde II effort, development of specific BDAMPER modules is continuing. BDAMPER 7.0 has been delivered, transitioned to GUIde industrial members, and successfully utilized in damper redesign. Work in 3D contact kinematics was completed earlier this year and the resulting impedance module was integrated into BDAMPER. Development of a simplified 3D wedge damper model was completed in September, and the associated subroutines are being integrated into BDAMPER. BDAMPER 8.0 will be transitioned to industry in early 2001.

Participating Organizations: GUIde

Points of Contact:

Government

Dr. Charles Cross
U.S. Air Force, AFRL/PRTC
1950 Fifth St, Bldg. 18D
Wright-Patterson AFB, OH 45433-7251
Phone: (937) 656-5530
Fax: (937) 656.5532
Email: charles.cross@wpafb.af.mil

Contractor

Dr. Chia-Hsiang Menq
Ohio State University
Department of Mechanical Engineering
The Ohio State University
Columbus, OH 43210-1107
Phone: (614) 292-4232
Fax: (614) 292-3163
Email: menq.1@osu.edu

5.1.8 Friction Damping in Bladed Disks

FY 97-01

Background

The objective of this project is to investigate the extreme sensitivity of shrouded bladed disk systems to small changes in the input variables. The final result will be a set of design tools and guidelines that can be used to develop robust shrouded bladed disk systems.

Recent Progress

An efficient and accurate reduced order model was developed that uses a subset of nominal modes to represent the response. The new approach makes it relatively easy to include aerodynamic coupling, mistuning, and friction nonlinearities in the analysis.

An initial version of the computer code that can be used for linear mistuning analysis has been released to GUIde Consortium members for their evaluation. It has the accuracy of a finite element analysis of a full bladed disk, but analyzes a specific case in seconds rather than the hours it would take to run a finite element analysis. The nonlinear version of the code has been validated for underplatform dampers. It has been extended so that it can also represent nonlinear shroud constraints. The shroud interface version of the code is currently being validated. It will be distributed to GUIde members for their evaluation after it has been fully documented.

Participating Organizations: GUIde

Points of Contact:

Government

Dr. Charles Cross
U.S. Air Force, AFRL/PRTC
1950 Fifth St, Bldg. 18D
Wright-Patterson AFB, OH 45433-7251
Phone: (937) 656-5530
Fax: (937) 656.5532
Email: charles.cross@wpafb.af.mil

Contractor

Dr. Jerry Griffin
Carnegie Mellon University
Department of Mechanical Engineering
Room 414/Scale Hall/5000 Forbes
Carnegie Mellon University
Pittsburgh, PA 15213
Phone: (412) 268-3860
Fax: (412) 268-3348
Email: jg9h@andrew.cmu.edu

5.2 Acquisition of Experimental Data

To validate advanced prediction models, experimental data is needed. The objective of the following projects is to obtain data necessary to validate modules for improved forced response prediction.

5.2.1 High Mach Forcing Functions

FY 92-96

The objective of this project was to acquire and analyze data defining the forcing functions generated by the wakes from rotor blades operating at high subsonic and transonic Mach numbers. Data for both the near and far wake were obtained in the Purdue High-Speed Compressor Facility (Fig. 65).

Concurrent to the experimental investigation, fundamental modeling was performed, utilizing current and advanced forced response unsteady aerodynamic models. The experimental data sets were acquired to provide benchmark data for validation of advanced computational fluid dynamic analysis codes. Flow topics which were investigated included rotor wake and potential forcing function blade row interactions, inlet guide vane (IGV) wakes, high-speed rotor wake vortical and potential forcing functions, transonic flow effects on acoustic modes, airfoil row wake interactions, and separated flow effects.

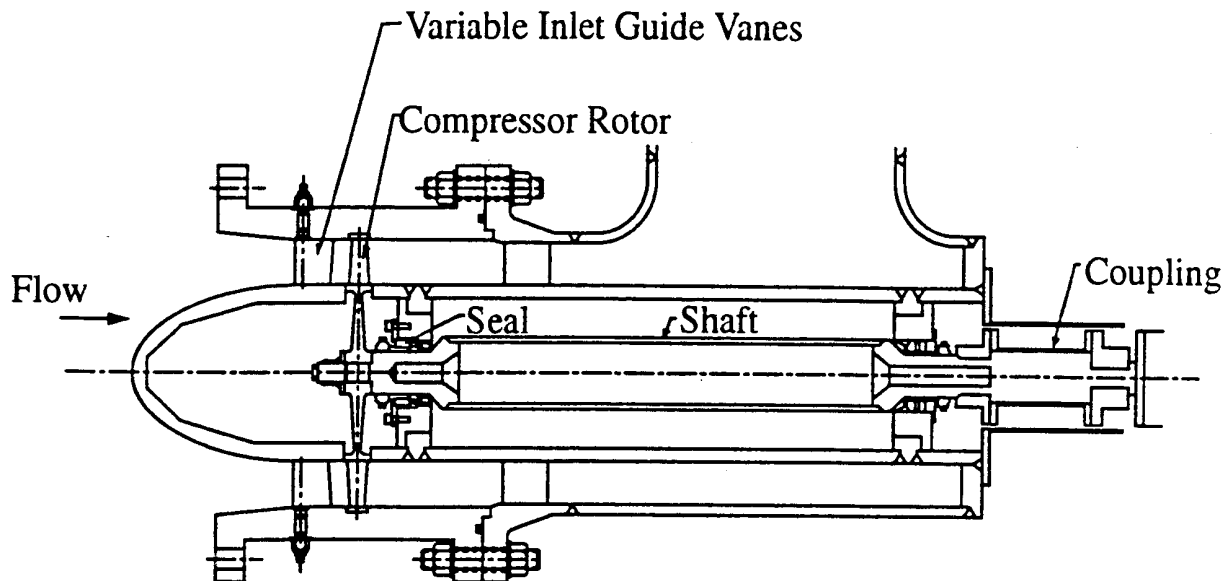

FIGURE 65. Purdue High-Speed Compressor Configuration: Single-Stage, 2/3 Hub-Tip Ratio Design, 18 Variable Inlet Guide Vanes, 19 Rotor Blades, Rotor Diameter 30.48 cm (12 in)

In this study, completed in 1996, the potential gust component of the rotor wakes upstream of the rotor was found to be dominated by the first harmonic component, with small contributions from the second and third harmonics. Higher harmonics of the vortical gust component of the rotor wakes measured both in and out of the IGV wakes are found to be significantly reduced in the IGV wake regions and

decay at a uniform rate due to viscous diffusion. Wakes were predominantly vortical for a Mach number near 1.0 and combined vortical-potential for supersonic flows. Interaction of the rotor wake with the IGV wake has a significant effect on the characteristics of both the IGV and rotor wakes. When the rotor blade wakes are in-phase with the IGV wakes, the IGV wake velocity deficit, semiwake width and total pressure losses increase.

Participating Organizations: GUIde, NASA

Point of Contact:

Government

Dr. Charles Cross
U.S. Air Force, AFRL/PRTC
1950 Fifth Street, Bldg. 18D
Wright-Patterson AFB, OH 45433-7253
Phone: (937) 656-5530
Fax: (937) 656-5532
Email: charles.cross@wpafb.af.mil

5.2.2 Forward Swept Blade Aeromechanics

FY 95-96

This effort involved application of available design/analysis tools to evaluate and predict the aeromechanical performance of a forward-swept rotor 1 of a two-stage test vehicle with inlet guide vanes. The rotor was tested at the WPAFB Compressor Research Facility (CRF) with instrumentation to measure and monitor the aeromechanical and aerodynamic behavior, both natural and forced. The aeromechanical goal of this effort was to evaluate the current aeromechanical design tools and practices needed to support the successful use of forward-swept blading. Also of interest was identification of unique aeromechanical problems in the design, in current design practice, or in the application of existing design tools.

Based on the testing results and comparison to the analytical predictions, the following conclusions are drawn. Empirical curves of current design practice are inadequate to predict the stability of forward-swept airfoils. The GAP software and analysis process is overly conservative for stability analyses. The NOVAK2D software and analysis process is a good tool but limited to nominal and low operating lines. The SIFOR forced-response analysis process yields fair correlation. Low-order modes have the best comparison. All tools and analysis processes need further development and improvement. Additional tools should be developed that are more accurate and applicable to more operating conditions, especially the high operating line.

This program produced a large amount of detailed data, and much of it was reduced and reviewed/evaluated. The acquired data add considerably to the available aeromechanical database, particularly for forward-swept airfoils. These data are available for, and will be very valuable to, the future improvement of existing analysis tools, design practices, and airfoil designs. Development of new, more powerful tools will benefit from this program and the data acquired. Enabling technology developed by this program will contribute to significant improvement in fan and compressor aerothermodynamics through implementation of forward-swept blade designs with lower development risk and cost.

Participating Organizations: Air Force Research Laboratory (AFRL), General Electric

Point of Contact:

Government

Mr. John Lueke
U.S. Air Force, AFRL/PRTF
1950 Fifth Street, Bldg. 18D
Wright-Patterson AFB, OH 45433-7251
Phone: (937) 255-8210
Fax: (937) 255-2077
Email: john.lueke@wpafb.af.mil

5.2.3 Oscillating Cascade Rig

FY 95-02

Background

The NASA linear oscillating cascade is one of a very few test facilities dedicated to unsteady aerodynamics of oscillating airfoils. The facility is used to investigate unsteady aerodynamic phenomena in an oscillating row of airfoils modeling self-induced cascade flutter. Experimental data acquired in this facility serve as benchmark sets to validate CFD codes for predictions applicable to real turbomachines, so that the data must be of the highest quality and reliability with characteristics sufficiently close to those encountered in annular cascades of real machines. However, achieving identical flow in linear and annular cascades is a very difficult task even for steady flow conditions.

Recent Progress

After an extensive effort in 1999 to improve flow uniformity and periodicity in the NASA Transonic Flutter Cascade, the work during the past year focused on improving blade instrumentation and studying the nature of separated flows on the suction side of the tested airfoil (Fig. 66).

Two additional blades were instrumented, each with 15 miniature pressure transducers. Four blades are now fully instrumented. However, due to the fragility of the transducers and connecting wiring we can get reliable signals from only about 40 transducers. We have initiated flutter tests. The selected measurement method is based on the influence coefficient technique because it can bypass some of the problems with data contamination experienced during the previous tests. Using this technique, only one blade is vibrated and the unsteady response is measured on all blades, with a linear superposition to obtain information in the travelling wave mode. The data are being acquired for the inlet Mach numbers of 0.5 and 0.8, incidence angle 10° , and blade frequencies of 200, 300, and 400 Hz. The amplitude of blade oscillations is 60.6° . The unsteady pressures will be measured on blades +2, +1, 21, and 22.

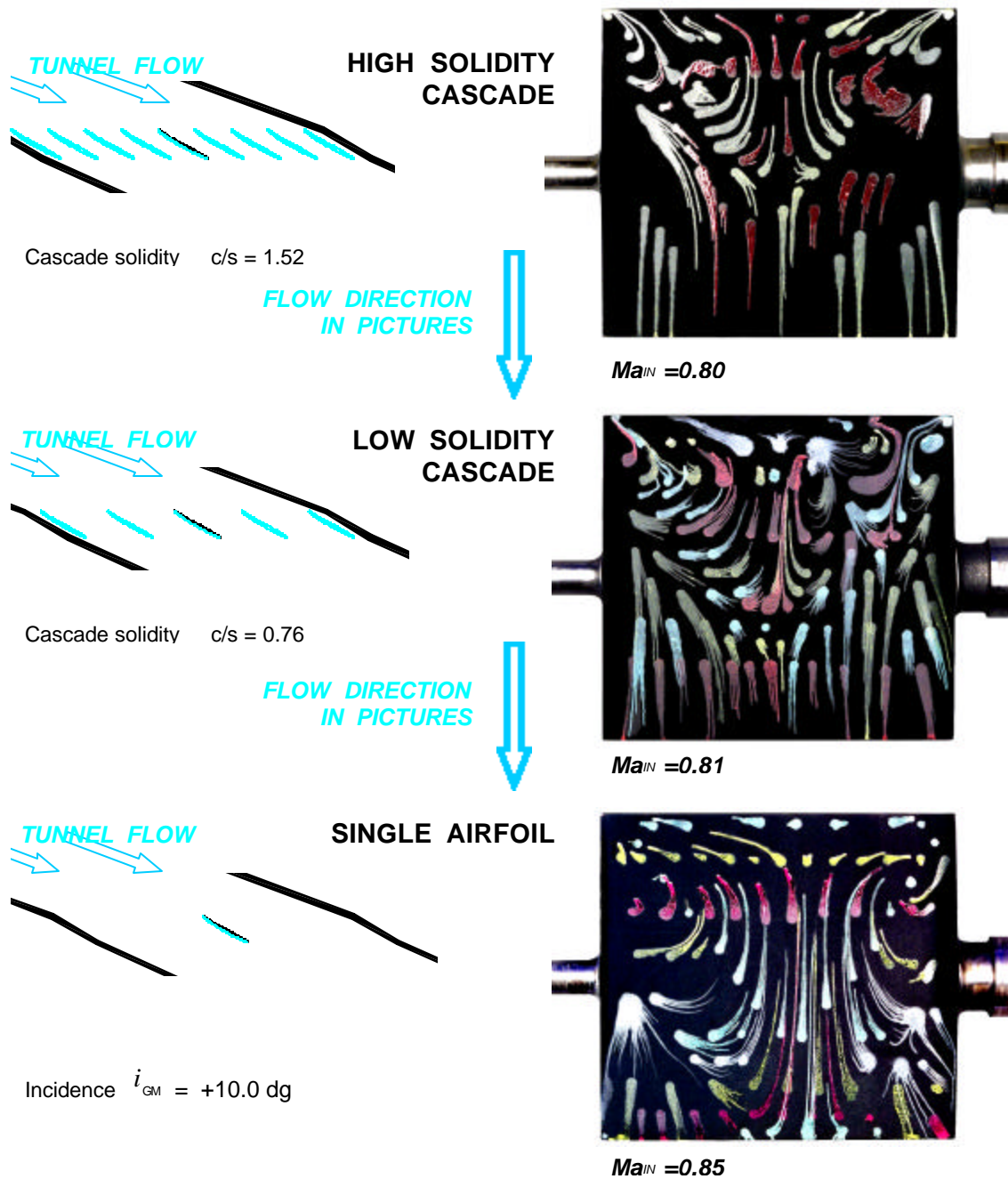

FIGURE 66. Surface Flow Patterns on the Airfoil Suction Side for High and Low Solidity Cascades and a Single Airfoil at Subsonic Inlet Flow Conditions

The second topic carried out this year was an extensive study to visualize the nature of the separated flows on the suction side of the tested airfoil. The study focused on two visualization techniques: surface flow visualization using dye oils, and schlieren (and shadowgraph) flow visualization. The following key observations were made during the study. For subsonic inlet flow, the flow on the suction side of the blade is separated over a large portion of the blade (up to 50% of the blade chord), and the separated area increases with increasing inlet Mach number. The flow in the separated region is highly three-dimensional. For the supersonic inlet flow condition, the flow is attached from the leading edge up to the point where a bow shock from the upper neighboring blade hits the blade surface. Low cascade solidity for the subsonic inlet flow results in an increased area of separated flow. For supersonic flow conditions, a low solidity results in an improvement in flow over the suction surface. Finally, computational results modeling the transonic cascade flowfield illustrate our ability to simulate these flows numerically.

Participating Organizations: NASA Glenn, Pratt & Whitney

Points of Contact:

Government

Dr. Jan Lepicovsky
Dynamics Engineering Co. / NASA Glenn
2001 Aerospace Parkway
Brookpark, Ohio 44142-1002
Phone: (216) 977-1402 or (216) 433-6207
Fax: (216) 977-1269
Email: jan.lepicovsky@lerc.nasa.gov

Contractor

Dr. Yehia El-Aini
Pratt & Whitney
P.O. Box 109600
West Palm Beach, FL 33410-9600
Phone: (561) 796-5911
Fax: (561) 796-3637
Email: elainiye@pwfl.com

5.2.4 F109 Unsteady Stator Loading

FY 95-01

Background

The objectives of the work are to collect, reduce, and analyze unsteady velocity data from the Honeywell F109 turbofan engine at the Air Force Academy in Colorado Springs, Colorado (Fig. 67). The specific areas of interest were upstream of the fan, or "fan forward" region, and upstream and downstream of the stators located behind the fan. All velocity data was taken with a two-wire hot wire, which was phase locked with the rotor. The conclusions drawn from the analysis of the "fan forward" data are that relatively large, unsteady, velocity disturbances are present in the flow approaching the fan. The unsteady potential field generated by the individual fan blades as they rotate causes these disturbances. The disturbances radiate at acoustic speed into the oncoming flow field in a spiraling helical pattern. The amplitude of the measured unsteady velocity is as high as 50% of the mean-axial-velocity very close to the fan, and is as low as 2-5% of the mean-axial-velocity at 1.0 fan chord (2.61 in) upstream of the fan. The data collected downstream of the fan indicates the presence of a convectively-propagating wake disturbance superimposed on an acoustically-propagating potential disturbance. These results confirm that it was the combination of these two disturbances that produced the unsteady pressure response measured on the surface of the stators in a previous effort.

Recent Progress

The effect this upstream propagating disturbance could have on engine hardware was investigated by placing an unloaded airfoil probe (hereafter referred to as the "vane") within one fan chord upstream of the rotor. The vane was instrumented with four Kulite ultraminiature pressure transducers on each side and concentrated toward the trailing edge. The results of the forced pressure response on this vane were greater by a factor of two than we expected based on the velocity field data. Near the trailing edge of the vane, unsteady peak-to-peak pressure amplitudes were recorded from 5 to 6 psia on one side of the vane and approximately 2 psia on the opposing side of the vane at the same chordwise location. This potential unsteady loading on the airfoil of 8 psia occurred in an environment where the flow's total pressure was only 11.4 psia. Future work will involve the possible relocation of the vane and experimental studies on a similarly instrumented vane with a blunt trailing edge in the spring of 2001.

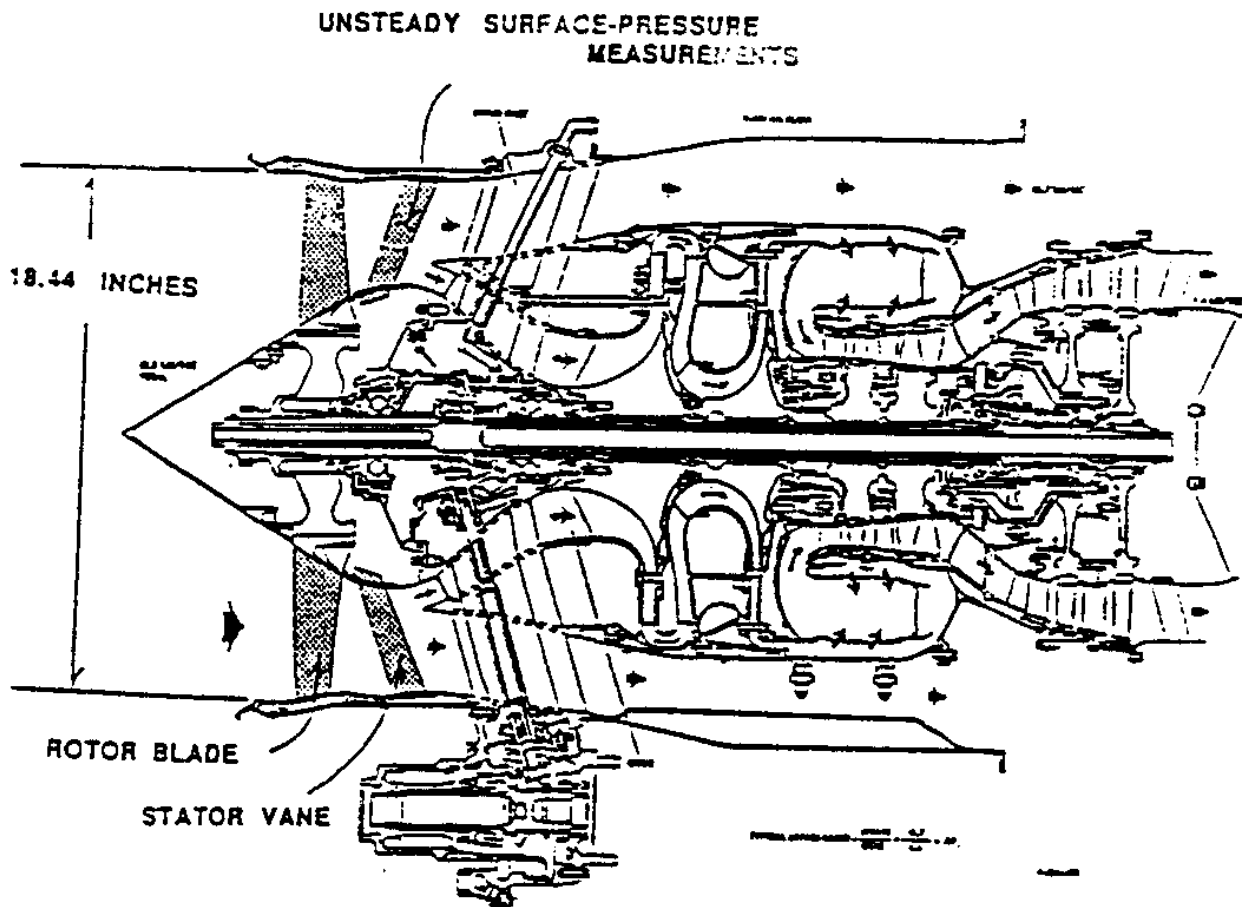

FIGURE 67. Schematic of F109 Engine Showing Location of Pressure-Instrumented Stators

Participating Organizations: U.S. Air Force Academy, Air Force Research Laboratory (AFRL), Air Force Office of Scientific Research (AFOSR), University of Notre Dame

Points of Contact:

Government

Maj Brenda A. Haven
U.S. Air Force Academy
Headquarters USAFA/DFAN
2354 Fairchild Dr., Suite 6H22
United States Air Force Academy
Colorado Springs, CO 80840-6222
Phone: (719) 333-3435
Fax: (719) 333-4013
Email: HavenBA.DFAN.USAFA@usafa.af.mil

Contractor

Dr. Eric Jumper
University of Notre Dame
Aerospace and Mechanical Engineering
Hessert Center for Aerospace Research
Notre Dame, IN 46556
Phone: (219) 631-7680
Fax: (219) 631-8355
Email: ejumper@aerosun.aero.nd.edu

5.2.5 Fluid-Structure Interaction (Fans)

FY 96-01

Background

The overall research objective is to develop the technology needed to predict significant blade row forced response in a multistage environment, thereby providing accurate predictions of HCF. Specific objectives include: (1) development of a benchmark standard multistage transonic research compressor; (2) a quantitative understanding and predictive capability for multi-stage blade row forced response; (3) addressing the inherently small damping of complex higher order modes, investigating techniques to control the flow induced vibrations; (4) considering the issue of robustness including the role of such issues as variability and flight maneuvers, nonlinearities, and fluid-structure interactions.

A transonic rotor operates with a supersonic relative velocity with a subsonic axial component. Shocks thus form near the leading edges that propagate upstream and are a significant forcing function to the upstream vane row. The rotor also generates an unsteady forcing function to the downstream stator row. The reduction in the relative velocity in the wake causes a decrease in the absolute velocity as well as a change in incidence to the downstream stators. This produces a fluctuating lift and moment that can result in large vibratory stress.

Recent Progress

The advanced-design IGV, rotor and stator rows have controlled diffusion airfoil (CDA) profiles and have been fabricated, with the IGVs and stators instrumented.

The new IGVs and stator vanes and the existing rotor were used in the investigation of IGV-rotor and rotor-stator interactions. Data obtained at the design rotor speed include the rotor-generated unsteady aerodynamic forcing functions to the upstream IGVs and downstream stators, the resultant IGV and stator unsteady aerodynamic response, and Particle Image Velocimetry (PIV) measurements of the instantaneous IGV and stator vane-to-vane flow fields.

The rotor-IGV interactions resulted in a highly unsteady IGV flow field, with the rotor leading edge shocks reflected by the vane pressure surface and diffracted by the suction surface. The reflected shock segment traveled across the vane passage as it propagated upstream, interacting with the incident

shock of the adjacent rotor blade before it eventually impacted the suction surface of the upper vane in the leading edge region. The IGV unsteady aerodynamic loading was very significant, with the maximum peak-to-peak static pressure fluctuations as large as 60% of the inlet total pressure.

The downstream stators periodically chop the rotor wakes, with the low momentum wake fluid drifting across the stator passage and accumulating on the pressure surface as the chopped wake segments are transported downstream. This intra-stator wake transport generates high levels of unsteady loading on the pressure surface at the transonic operating condition.

The development of a computational analysis of unsteady multistage flows in turbomachinery was continued. For a given multistage fan or compressor, a computational mesh for each blade row is first generated. The steady multistage flow is then computed using conventional CFD techniques, with "mixing planes" used to couple together the solutions computed in the individual blade rows. Several unsteady time-linearized (frequency domain) problems on each computational grid are then solved. Each solution is identified with one of a set of discrete "spinning modes," each with a different frequency and interblade phase angle. These unsteady flow problems are solved in parallel, using time-linearized CFD techniques developed for isolated blade rows. At each iteration, information is exchanged among the various spinning mode solutions at the inter-row computational boundaries. This iteration procedure is continued until a converged solution is obtained. The three-dimensional analysis technique has been considerably refined. Specifically, the aerodynamic damping of a rotor embedded in a multistage machine can now be computed.

Flow induced vibrations in turbomachine blade rows is a coupled fluid-structure problem. To begin to address the need for a coupled interacting fluid-structures analysis, the finite element code ALE3D (Arbitrary-Lagrangian-Eulerian-3D) that solves the three-dimensional Euler equations is being extended for application to turbomachines. For each time step, a Lagrangian calculation is performed, the mesh relaxed, and new flow quantities are found via an advection calculation. The outer portion of the mesh is relaxed to its original position, while the inner portion is relaxed to reduce mesh skewness due to blade motion. Thus, in TAM-ALE3D (Turbomachinery-Aero-Mechanics-Arbitrary-Lagrangian-Eulerian-3D), the same finite element model is applied to both the blading and the fluid, resulting in consistency between the fluid and structure. Hence, the exchange of energy and momentum across the fluid-structure boundary is not prone to phase-lagging errors that tend to act as energy sources or sinks at the fluid-structure boundary. The TAM-ALE3D coupled interacting fluid-structure analysis enables the vibratory stress to be predicted. This was demonstrated through a simulation of the blade-row-interaction-generated flow and vibration phenomena in the IGV row of the Purdue Transonic Compressor.

Research under this initiative will include continued analytical development of multistage effects as well as fluid-structure interactions. Continued experimental research includes the investigation of the stator response at part-speed rotor conditions, the measurement of the vibratory stress in the IGVs and stators, as well as the study of airfoil-to-airfoil unsteady aerodynamic variability. Finally, the new rotor will be installed, with investigations into rotor-stator and rotor-IGV interactions initiated, and the airfoil response for each airfoil row measured.

Participating Organizations: AFOSR, Purdue University, Duke University, Pratt & Whitney

Points of Contact:

Government

Dr. Thomas Beutner
U.S. Air Force, AFOSR/NA
801 N. Randolph Street
Arlington VA 22203-1977
Phone: (703) 696-6961
Fax: (703) 696-8451
Email: tom.beutner@afosr.af.mil

Contractor

Dr. Sanford Fleeter
Purdue University
Thermal Sciences & Propulsion Center
1003 Chaffee Hall
West Lafayette, IN 47907-1003
Phone: (317) 494-1504
Fax: (317) 494-0530
Email: fleeter@ecn.purdue.edu

5.2.6 Experimental Study of Forced Response in Turbine *FY 97-00*

Background

The purpose of this project was to develop an understanding of the forcing function, aerodynamic damping, and structural damping at actual engine conditions for high-frequency vibration of turbine blades. A Honeywell TFE731-2 high-pressure turbine stage was fully instrumented and a measurement/analysis program was conducted at the Gas Turbine Laboratory of the Ohio State University. The original blades had a high-frequency vibration problem. Unsteady surface pressure and blade response were measured as part of the effort. The result of this research project will be a database that can be used to validate future predictive codes. Because of significant reductions in funding, the original test plan, which included operating the turbine at actual engine conditions, had to be scaled down such that the measurements were performed for corrected engine conditions.

Recent Progress

The research program has been completed and funding has been exhausted. A final report titled "Experimental and Numerical Study of Blade Forced Response in a Full-Scale Rotating Turbine" describing the effort and including the database was distributed to all members of the government, industry, and university partners of the GUIde Consortium on September 18, 2000. A brief abstract of the contents of the report follows.

Abstract of Report: The forced response of aircraft engine turbine blades has been studied with a careful combination of numerical predictions and experimentation to provide a data set and accompanying analysis of the coupled unsteady aerodynamics and structural response. The unsteady aerodynamics through the stage are modeled using the Quasi-3D Reynolds-averaged Navier-Stokes CFD solver (UNSFLO) and the structural response of the blade is modeled with the 3D finite element commercial code ANSYS. The measurement program utilized full-stage rotating engine hardware operating at design corrected conditions that had experienced previous forced response difficulties while in service. Two different vane/blade spacings were used in the measurement program in order to investigate the influence of this variable on the resulting forcing function. The rotating blade was instrumented with flush-mounted miniature pressure transducers, strain gauges, and piezoelectric crystals. Both aerodynamic and piezoelectric excitation techniques were used to study the blade vibratory response with and without aerodynamic loading. In this way, it was possible to measure the

total damping and to obtain an accurate estimate of the contributions from structural and aerodynamic sources.

The results provide for the first time the coupled measurement of unsteady pressure and vibratory response of a high-pressure turbine blade due to vane/blade interaction. Comparison of the predictions and time-averaged surface pressure data demonstrated good agreement. Similar comparisons of the pressure harmonic amplitudes showed good agreement at midspan and moderate agreement near the tip. The results indicate a significant decrease in the amplitude of the pressure harmonic when the vane/blade spacing is increased.

The unsteady pressure field was analyzed prior to and during resonance. Vibration acts as a destructive interference with the vane wake forcing function during resonance. For this particular turbine, aerodynamic damping was found to be a large component of the total damping. Successful completion of this database provided a needed data set for the study of turbine blade forced response.

Participating Organizations: GUIde, NASA

Points of Contact:

Government

Dr. Antole Kurkov
NASA Glenn Research Center
NASA Glenn Research Park
21000 Brookpark Rd., M/S 49-8
Cleveland, OH 44135-3191
Phone: (216) 433-5695
Fax: (216) 977-7051
Email: kurkov@grc.nasa.gov

Government

Dr. Charles Cross
U.S. Air Force, AFRL/PRTC
1950 Fifth St, Bldg. 18D
WPAFB, OH 45433-7251
Phone: (937) 656-5530
Fax: (937) 656-5532
Email: charles.cross@wpafb.af.mil

Contractor

Dr. Michael Dunn
Ohio State University
328 Bowlz Hall
2036 Neil Ave.
Columbus, OH 43210-1276
Phone: (614) 292-8453
Fax: (614) 292-8290
Email: dunn.129@osu.com

5.3 Validation of Analytical Models

The objective of the following projects is to utilize existing experimental data to validate models for improved forced response prediction.

5.3.1 Evaluation of Current State-of-the-Art Unsteady Aerodynamic Models for the Prediction of Flutter & Forced Vibration Response *FY 97*

Background

The objective of this project was to evaluate the capabilities of current state-of-the-art unsteady aerodynamic models that attempt to predict the gust and oscillating airfoil response of compressor and turbine airfoils over a range of realistic frequencies and loading levels. Additionally, the effect of the aerodynamic forcing function on gust response, and the effects of three-dimensional flow on airfoil oscillation will be investigated. Codes utilized were primarily NASA Glenn codes, such as Nphase, Sflow, Linflow, and Linflux.

Final Results

This program was terminated when the principal investigator left academia. However, an initial investigation into the capabilities of two state-of-the-art computational models was performed. The unsteady pressure and first harmonic unsteady surface pressure coefficients determined from experiments were correlated with the predictions. The experimental data used was for the NASA/PW fourth standard configuration. Viscous and inviscid flow solutions were generated.

Participating Organizations: Air Force Research Laboratory (AFRL), GUIde

Point of Contact:

Government

Dr. Charles Cross
U.S. Air Force, AFRL/PRTC
1950 Fifth Street, Bldg. 18D
Wright-Patterson AFB, OH 45433-7253
Phone: (937) 656-5530
Fax: (937) 656-5532
Email: charles.cross@wpafb.af.mil

5.3.2 Evaluation of State-of-the-Art Unsteady Aerodynamic Models *FY 99-02*

Background

The objective of this project is to evaluate the capabilities of current state-of-the-art unsteady aerodynamic models that attempt to predict the gust and oscillating airfoil response of compressor and turbine airfoils over a range of realistic frequencies and loading levels. Additionally, the effect of the aerodynamic forcing function on gust response and the effects of three-dimensional flow on airfoil oscillation will be investigated. Codes currently under evaluation are TURBO, ADPAC, and 3DVBI.

Recent Progress

Research utilizing the 3DVBI, ADPAC and TURBO codes is ongoing. All three codes are being used to compare to high speed transonic unsteady surface pressure experimental data obtained on the Stage Matching Investigation (SMI) test article in the Air Force Research Laboratory's Compressor Aero Research Laboratory (CARL). In addition, comparisons will be made to SMI Particle Image Velocimetry (PIV) velocity data between the inlet guide vanes and the rotor. Initial comparisons are being made at a subsonic operating point with transonic comparisons to be obtained next. Steady-state comparison of 3DVBI and ADPAC to the IGV-generated forcing function data found good agreement in the core flow regions.

Participating Organizations: Air Force Research Laboratory (AFRL), Wright State University

Points of Contact:

Government

Dr. Charles Cross
U.S. Air Force, AFRL/PRTC
1950 Fifth Street, Bldg. 18D
Wright-Patterson AFB, OH 45433-7253
Phone: (937) 656-5530
Fax: (937) 656-5532
Email: charles.cross@wpafb.af.mil

Contractor

Dr. Mitch Wolff
Department of Mechanical Engineering
Wright State University
Dayton OH 45435
Phone: (937) 775-5141
Fax: (937) 775-5009
Email: mitch.wolff@wright.edu

5.3.3 Forced Response Prediction System (Fans)

FY 95-01

Background

The objective of this project is to develop and validate NASA's new Forced Response Prediction System design tools. Three codes are being developed for forced response predictions: FREPS, FREED, and TURBO. FREPS uses two-dimensional linearized potential unsteady aerodynamics and is the fastest running of the codes. The development and validation of FREPS is complete and is being followed by the development of FREED. FREED uses steady Euler aerodynamics from the TURBO code, and linearized three-dimensional unsteady Euler aerodynamics from LINFLUX. LINFLUX is a turbomachinery code developed under a contract from NASA Glenn Research Center (formerly Lewis Research Center). The linearized code FREED and the fully non-linear code TURBO (with aeroelastic capability) are complimentary. Both codes are based on the same algorithm, but each provides a different level of physics modeling and has different computational requirements. The TURBO code, described elsewhere in this report, is the longest running of the three codes but includes the most physics modeling. The structural dynamic model of the blade for the three codes is based on a normal mode representation.

Recent Progress

A preliminary version of the FREED code has been developed and verified. An interface routine has been developed to read the steady aerodynamic solution from TURBO-v4. Additional routines have been developed to interpolate the structural modal displacements onto the aero-grid, to calculate the generalized forces, eigenvalues, and structural response. Initial stability calculations have been done for a helical fan configuration with twisted flat plate blades, and for the E-cube fan configuration. Since the main intent was to develop the required modules for FREED, only a coarse grid was used in the calculations. These development and verification efforts have been documented in paper AIAA-2000-3230. Future plans include further verification and validation of the FREED code, use of the latest version of the LINFLUX code (which includes the new capability to model incoming vortical gusts), and development of a new interface code to work with the most recent version of TURBO. In addition, the plans include improvement of the steady solver to obtain faster convergence and to obtain solutions with reduced numerical losses.

Participating Organizations: NASA

Points of Contact:

Government

Oral Mehmed
NASA Glenn Research Center
NASA Glenn Research Park
21000 Brookpark Rd., M/S 49-8
Cleveland, OH 44135-3191
Phone: (216) 433-6036
Fax: (216) 977-7051
Email: oral.mehmed@lerc.nasa.gov

Contractor

Milind Bakhle and Rakesh Srivastava
University of Toledo
NASA Glenn Research Park
21000 Brookpark Rd., M/S 49-8
Cleveland, OH 44135-3191
Phone: (216) 433-6037 (Bakhle)
(216) 433-6045 (Srivastava)
Fax: (216) 977-7051 (Both)
Email: Milind.A.Bakhle@grc.nasa.gov
Rakesh.Srivastava@grc.nasa.gov

5.3.4 Aeromechanical Design System Validation

FY 96-01

Background

Analytic attempts to predict blade-to-blade vibration amplitude variations have continued this past year. The goals of this program are:

- (1) Determine if the vibration amplitude variations caused by mistuning observed in both bench tests and engine tests can be predicted by using full rotor finite element analysis.
- (2) Determine if and under what conditions “stiffness” mistuning sufficiently characterizes blade-to-blade variability to predict mistuning effects.
- (3) Determine if mistuning reduced order models (ROMs) can produce accuracy equivalent to that of full rotor models, along with large savings in the computer resources required for analysis.

Recent Progress

Three full rotor finite element models have been built:

- (1) A full rotor model with each blade modeled identically. This model will be used to gain confidence in the validity of the full rotor modeling technique.
- (2) A full rotor finite element analysis with each blade modeled based on the measured geometry (geometric mistuning).
- (3) A full rotor model with each blade modeled with identical geometry but different elastic modulus to cause the blade alone frequency of each blade to match bench data (stiffness mistuning). There are several of these models, each having a different set of blade moduli based upon experimentally obtained frequencies for each blade mode in the range of interest.

The comparison of these three finite element models continues. We compared the modeshape of the geometric and stiffness mistuned models. A direct visual modeshape comparison showed that some of the modes agreed well while others agreed poorly. To help quantify the modeshape differences, a fit parameter was used. Initial comparisons of the fit parameter for the geometry mistuned versus tuned full rotor models showed that some modes agreed well while others agreed poorly. To help better understand these differences, the blade alone modeshape of the actual blades and the nominal blades were compared. These comparisons showed that the modeshape differences between the geometric and stiffness mistuned full rotor models is caused by mistuning effects and not by blade alone modeshape effects.

Comparison of results from the stiffness and geometry mistuned models will continue to include forced response analyses. Forced response analyses will be conducted using different harmonic excitations, over each of the two distinct frequency ranges used in the lab. Each of the full rotor models, geometrically mistuned and stiffness mistuned, will be used for these analyses. Results from each of the two models will be compared to results obtained by analytically forcing the experimental transfer matrices.

Mode identification will continue until an experimental nodal diameter map is generated. Upon completion, experimental-versus-analytical comparisons will be concentrated on the forced response.

Participating Organizations: Air Force Research Laboratory (AFRL), Pratt & Whitney

Point of Contact:

Government

John Lueke
U.S. Air Force, AFRL/PRTF
1950 Fifth Street, Bldg. 18D
Wright-Patterson AFB, OH 45433-7251
Phone: (937) 255-8210
Fax: (937) 255-2077
Email: john.lueke@wpafb.af.mil

5.4 New Efforts

FY 01-06

With the extension of the HCF program, additional research in the Forced Response area is planned. Future research includes the *characterization and prediction of flow in hybrid and non-axial flow systems*. *Investigations of impeller-diffusor interactions, splintered rotors, and innovative compressive designs* will enhance the community's ability to predict the response of advanced systems. Research performed through the GUIde Consortiums in *friction damping* and in the *development of the BDAMPER series of codes* will be continued and extended into microslip and small engine damping mechanisms. *Mistuning prediction and characterization*, transitioned through REDUCE and SNM, will continue and be enhanced through efforts that strive to optimize the effect of mistuning in a system. Finally, *efforts to develop the tools necessary for a fully integrated, versus coupled, forced response prediction system* will be pursued.

5.5 Conclusion

The Forced Response Action Team has successfully developed models to understand and predict friction and mistuning in gas turbine engine disks. Updates of models were transitioned to industry in this past year. An updated version of BDAMPER, a code developed through the GUIde Forced Response Consortium, is successfully predicting resonant responses of frictionally constrained blades. New versions of REDUCE and SNM, bladed disk mistuning codes, are being utilized by several turbine engine companies, and are successfully predicting response trends in bladed disk assemblies. Additionally, the government and industry are jointly pursuing new codes for flutter and resonant stress prediction. Many efforts have been coordinated and developed through the GUIde consortium of government, engine contractors, and universities, with validation performed through basic research, component rig testing, and production engine operation.

6.0 PASSIVE DAMPING TECHNOLOGY



BACKGROUND

The Passive Damping Technology Action Team (Damping AT) has the responsibility of fostering collaboration between individual HCF passive damping efforts with the overall goal of damping component resonant stress by 60% for fans and 25% for turbines. The Damping AT provides technical coordination and communication between active participants involved in HCF passive damping technology. Annual technical workshops have been organized and summaries of these workshops are disseminated to appropriate individuals and organizations. The Chair, Co-Chair and selected Damping AT members meet as required (estimated semi-annually) to review damping activities, develop specific goals for passive damping programs, and coordinate with the TPT and IAP. The Chair (or Co-Chair) of the Damping AT keeps the TPT Secretary informed of AT activities on a frequent (at least monthly) basis. This AT includes members from government agencies, industry, and universities who are actively involved in damping technologies applicable to engine HCF. The team is to be multidisciplinary with representatives from multiple organizations representing several component technologies as appropriate. The actual membership of the AT may change in time as individuals assume different roles in related projects.

ACTION TEAM CHAIRS

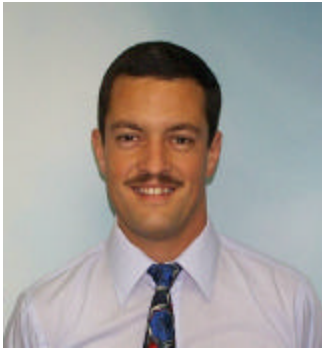

Chair
Mr. Frank Lieghley, Jr.
U.S. Air Force, AFRL/PRTC
1950 Fifth Street, Bldg. 18D
WPAFB, OH 45433-7251
Phone: (937) 255-1867
Fax: (937) 255-2660
Email: frank.lieghley@wpafb.af.mil



Co-Chair
Mr. Ray Pickering
NAVAIR/NAWCAD
Propulsion & Power Engineering
Building 1461
48298 Shaw Road Unit 4
Patuxent River, MD 20670-1900
Phone 301-342-0873
FAX 301-342-4781

INTRODUCTION: The following pages contain tables, schedules, backgrounds, and summaries of the recent progress of current and planned tasks managed by this action team.

Passive Damping Research Schedule

Product	FY95	FY96	FY97	FY98	FY99	FY00	FY01	FY02	FY03	FY04	FY05	FY06
6.1 Identification & Characterization of Damping Techniques												
6.1.1 Mechanical Damping Concepts												
6.1.2 Air Force In-House Damping Investigations												
6.1.3 Centrifugally Loaded Viscoelastic Material Characterization												
6.1.4 Damping for Extreme Environments												
6.1.5 Centrifugally Loaded Particle Damping												
6.1.6 Coatings for Damping Turbine Engine Components												
6.1.7 Development of Air Film Damping for Turbine Engine												
6.2 Modeling & Incorporation of Damping in Components												
6.2.1 Advanced Damping Concepts for Reduced HCF												
6.2.2 Evaluation of Reinforced Swept Airfoils / Internal Dampers												
6.2.3 Damping Systems for IHPTET												
6.2.4 Damping for Turbines												
6.2.5 Dual Use Program												
6.2.6 Transition of Damping Technology to Counterrotating LPT												
6.3 Affordable Damped Components												

6.1 Identification and Characterization of Damping Techniques

Four types of passive damping systems, judged to have a reasonable chance of effectively damping rotating engine components, are being investigated: (1) friction damping systems, which have been used in platform and shroud applications and now show promise as devices internal to blades, (2) viscoelastic material systems, which have mature design optimization procedures and are now being designed to function under high centrifugal loads, (3) particle damping systems, which have the potential of providing damping independent of temperature, but require a lot of effort in characterization and design optimization, and (4) powder damping systems, which are an extension of the tribology of dry film lubricants, have temperature independent damping, and require the most work in the development of acceptable systems.

6.1.1 Mechanical Damping Concepts

FY 95-01

Recent Progress

For the past year, researchers at NASA Glenn Research Center (GRC) have been investigating several damping methods for rotating blades. Oral Mehmed, NASA Senior Research Engineer, and Dr. Kirsten Duffy of the Ohio Aerospace Institute have been studying the self-tuning impact damper. Oral Mehmed has also been working with Dr. John Kosmatka at the University of California at San Diego to investigate viscoelastic damping in composite blades.

A self-tuning impact damper was tested in 2000 that significantly reduced resonant vibrations at engine order crossings. The frequency of motion of the damper is proportional to the rotor spin rate, causing it to function along an engine order line. Tests were performed in flat aluminum plates in the NASA Dynamic Spin Facility (Fig. 68) with a magnetic bearing excitation system. Damping of up to 1.0% critical was obtained at 7250 g's at the engine order crossings over a baseline damping of about 0.2%. In order to show the feasibility of damping for very thin blades, a test will be performed in November 2000 on a miniaturized self-tuning damper. Here, very small impactors are distributed over an area of a plate, simulating the application of the damper in a fan blade. A second test will feature the dampers installed in a Pratt and Whitney turbine blade. Both tests will be performed in the NASA Dynamic Spin Facility with a new eddy current engine order excitation system manufactured by Hood Technologies.

Research is also being conducted in the area of integrally damped composite blades. The objective of this research is to develop technology to passively damp blades made of composite material by designing and fabricating the blades with viscoelastic material built in. Earlier analytical and experimental research with spinning composite plates showed that the concept works and that the damping benefits are significant. New analytical and spinning research completed in 2000 also gave encouraging results. A scaled model of an integrally damped modern composite fan blade had a significant damping increase compared to an undamped blade and no structural failure up to 20,000 g's. The damping design focused on maximizing the blade damping for a specific rotating speed range and mode, while maintaining the initial structural static and dynamic properties.

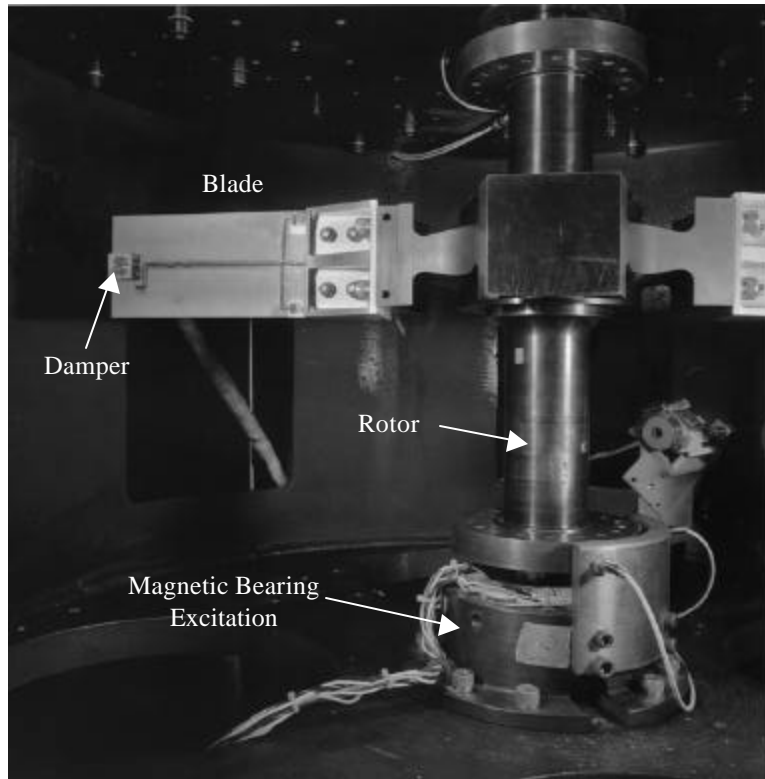

FIGURE 68. Dynamic Spin Facility, NASA Glenn Research Center

Participating Organizations: NASA, University of California, Ohio Aerospace Institute, University of Texas at San Antonio

Points of Contact:

Government

Dr. Kirsten Duffy
Ohio Aerospace Institute
NASA Glenn Research Center MS 49-8
21000 Brookpark Road
Cleveland, OH 45135
Phone: (216) 433-3880
Fax: (216) 977-7051
Email: Kirsten.P.Duffy@grc.nasa.gov

Contractor

Dr. John Kosmatka
University of California at San Diego
Department of Structural Engineering
9500 Gilman Dr.
La Jolla, CA 92093-0085
Phone: (858) 534-1779
Fax: (858) 822-2260
Email: jkosmatka@uscd.edu

6.1.2 Air Force In-House Damping Investigations

FY 95-99

Background

The objective of this task was to investigate the use of piezoelectric actuators to increase coupling in an integrally bladed rotor. Mistuning can cause blades to experience much higher operating stresses than would occur in a perfectly tuned system. Increasing blade-to-blade coupling can reduce this non-uniformity. In this task, piezoelectric actuators were attached to an integrally bladed disk and modal tests were conducted to assess the amount of additional coupling provided by the actuators.

Ideally, a bladed disk is a periodic system with the substructures and blades all having identical natural frequencies. However, there will be slight variations in the blades. These variations mistune the individual blade natural frequencies and affect the system as a whole. The dynamic behavior of the bladed disk depends on the degree of mistuning and coupling that exists in the system. When the amount of mistuning is small or the coupling is strong, the mode shapes are said to be extended, i.e., they are regular patterns that involve all the blades. As the mistuning is increased or the coupling weakens, the mode shapes tend to become irregular, with amplitude concentrated in a few blades.

Piezoelectric strain actuators have been used to add damping to structures. These actuators have the potential to augment the coupling of engine blades. As a blade deforms during vibration, an electrical charge is induced in a strain actuator located in an area of high modal strain on the blade. The induced charge can then be transferred through an electric circuit to an actuator on another blade causing the second blade to also deform. This sharing of energy between blades is similar to connecting the two blades with a mechanical spring.

Final Results

Experiments were conducted on a model jet engine fan to evaluate the effects of piezoelectric coupling of blades on mode shapes. The model fan, shown in Figure 69, was used as the test article in this study. It is a variant of a model developed under a previous study and is representative of a modern fighter engine's first-stage fan.

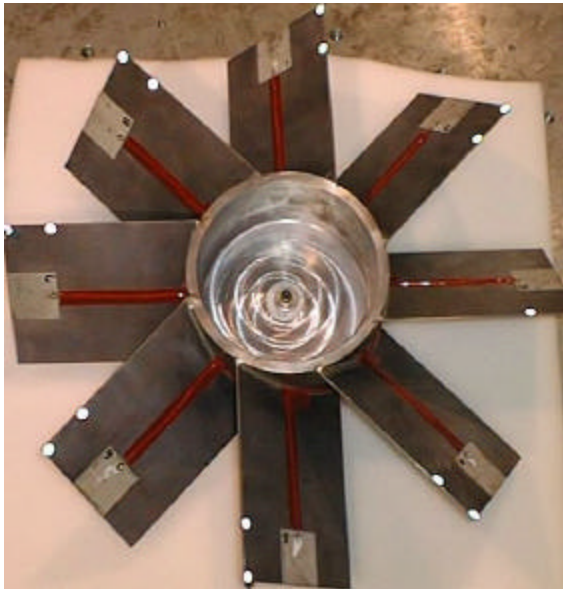

FIGURE 69. Model Fan Test Article

The model fan had an overall diameter of 18 inches. The blades and hub were fabricated from low-alloy steel. The blades were soft soldered into slots in the hub at a 45° angle to the fan's axis of rotation. The blades were 6 inches long, 4.5 inches wide and 0.063 inches thick. The cylindrical hub had a diameter of 6 inches. The hub wall thickness was 0.325 inches.

The two-stripe family of modes was chosen for study. Piezoelectric strain actuators were placed on the blades in an area of high modal strain for the local two-stripe mode shape. Each piezoelectric strain actuator was a sheet of G-1195 lead zirconate titanate (PZT). The dimensions of each actuator were 1.5 inches by 1.5 inches by 10 mils thick. Actuators were

bonded to the front and back of each blade. The location of the front actuators are apparent in Figure

70, the back actuators are at the same locations on the other side of the blades. The negative side of each actuator is electrically grounded to the fan using conductive adhesive.

The model fan was inherently mistuned due to small variations in the blades. The natural frequencies of the individual blades (with all sensors, actuators, and wiring in place) were measured to quantify the mistuning. The frequency of each blade was measured, one at a time, by adding small tip masses to the other blades to “detune” them and localize the mode shape to the blade of interest. The average natural frequency measured was 789.4 Hz. The frequency spread from the highest to the lowest frequency blade was 10 Hz or 1.3% of the average frequency.

In addition to studying the effects of coupling on the mistuned model, it was desired to test the model in a nearly-tuned configuration. To tune the model, the natural frequencies were altered through the addition of small masses to each blade. A trial and error procedure was used to decrease the frequency spread from 10 Hz to 0.5 Hz. The spread is only 0.06% of the new average frequency of 783.7 Hz. This configuration will be referred to as the "tuned" fan.

The piezoelectric actuators can be electrically connected to achieve many coupling arrangements. In previous work with an analytical model, a single coupling spring was used to couple adjacent blades. The piezoelectric actuators on the model fan were connected to mimic this model. Each front piezoelectric actuator was connected to the back actuator of the next blade, as depicted in Figure 70.

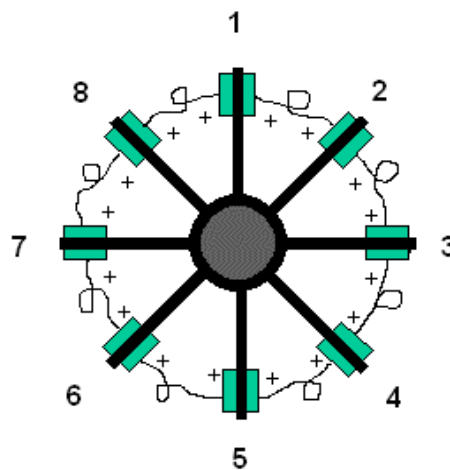

FIGURE 70. The Electrical Connections between Piezoelectric Actuators

The mode shapes for a perfectly tuned system, often called the extended mode shapes, are shown in Figure 71. Extended mode shapes can also occur with a mistuned system if the coupling is strong enough. Achieving extended mode shapes and therefore tuned forced response behavior was the goal of the coupling experiments. For the mode shapes depicted in Figure 71, the length of the radial line in the 12 o'clock position represents the relative modal amplitude of blade 1. The amplitudes of blades 2-8 are represented by the other seven radial lines (numbered clockwise). Solid lines represent blades vibrating in-phase and dotted lines represent blades vibrating out-of-phase. The orientations of the three orthogonal pairs of modes (2-3, 4-5, and 6-7) are arbitrary.

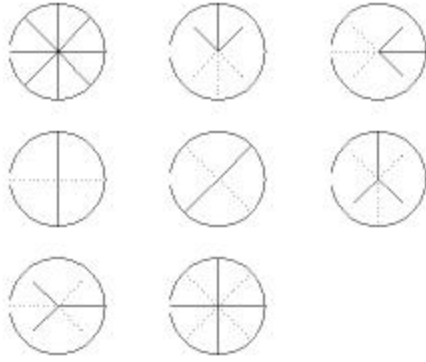

FIGURE 71. Extended Mode Shapes for Eight Blades

Two tests were conducted on the model fan in the mistuned configuration. In the first case, the piezoelectric couplers were not connected and left in the open electrical boundary condition. This case will be referred to as the mistuned, uncoupled case. In the second case, the couplers were connected as shown in Figure 73. This case will be referred to as the mistuned, coupled case.

Modal results for the mistuned, uncoupled case are shown in Figure 72. The mode shapes are generally localized. Modes 1-3, 7, and 8 are mostly localized to a single blade. The other three modes, 4-6, primarily involve blades 2, 3, and 8. These results are readily inferred from the individual blade frequencies. That is, the tendency for two blades to participate in the same mode is directly related to the difference in their individual frequencies.

It is evident from Figure 72 that inter-blade coupling for the two-stripe mode family is very weak. As discussed previously, extended modes (tuned behavior) can result from either of two conditions—coincident frequencies or large inter-blade coupling. The mode shapes indicate very weak coupling, since the blades that do not have nearly-coincident frequencies are mostly localized. This behavior is to be expected from the two-stripe mode family since the local mode shape has very little strain energy near the blade root and thus has poor means for coupling through the hub. Therefore, a large increase in coupling of the two-stripe family is needed to achieve extended behavior.

Modal results for the mistuned, coupled case are shown in Figure 73. A moderate increase in coupling is evident. Generally speaking, each mode shows increased participation from all the blades. The piezoelectric coupling has caused blades 4 and 7, which were previously localized, to strongly interact with blades 2, 3, and 8. Modes 1, 7, and 8 are still mostly localized to blades 6, 5, and 1, respectively, but there is some small participation of adjacent blades. Although the overall coupling has improved, the resulting mode shapes are far from the extended case. The added coupling from the piezoelectric actuators is too weak to have the desired results.

After it was determined that the piezoelectric coupling was not strong enough to achieve extended modes in the mistuned fan, it was decided to see if the coupling could force extended modes in a nearly tuned system. The blades were “tuned” as described previously, and modal tests were conducted for two coupling cases. In the first case, the piezoelectric couplers were not connected and left in the open electrical boundary condition. This case will be referred to as the tuned, uncoupled case (Fig. 74). In the second case, referred to as the tuned, coupled case, the couplers were connected as shown in Figure 75.

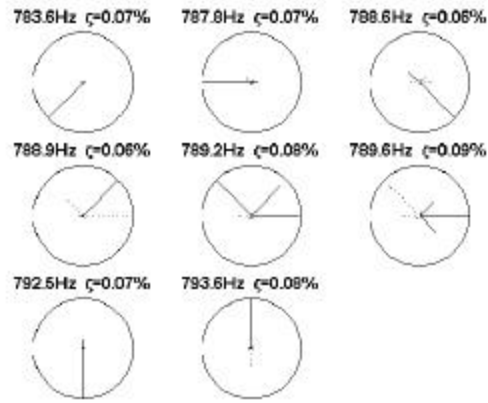

FIGURE 72. Mode Shapes for the Mistuned, Uncoupled Case

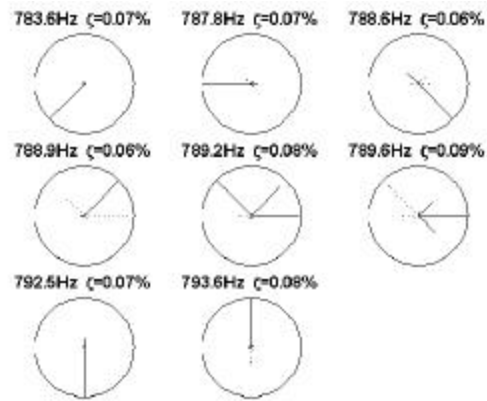

FIGURE 73. Mode Shapes for the Mistuned, Coupled Case

The modal results for the tuned, uncoupled case are shown in Figure 74. There is significant participation of most blades in most modes, but only three of the mode shapes (5, 7, and 8) appear to approach the extended mode shapes.

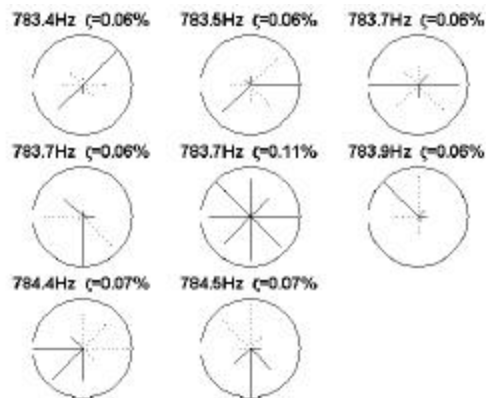

FIGURE 74. Mode Shapes for the Tuned, Uncoupled Case

The modal results for the tuned, coupled case are shown in Figure 75. All the mode shapes closely approximate the extended mode shapes and are in the proper order. With the system nearly tuned, the added coupling from the piezoelectric actuators is sufficient to cause the extended shapes to appear.

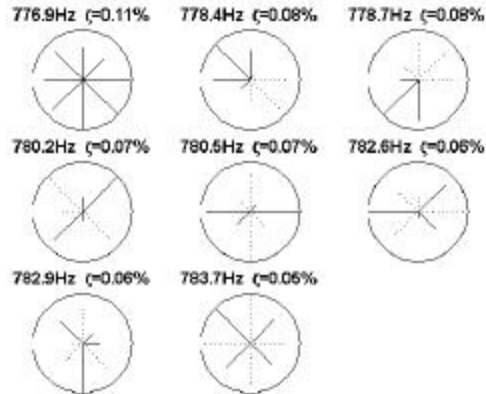

FIGURE 75. Mode Shapes for the Tuned, Coupled Case

The results indicate that the piezoelectric actuators did improve blade-to-blade coupling, but the improvement was weaker than hoped. Only the tuned, coupled configuration was able to achieve the desired extended mode shapes. The disappointing performance of the piezoelectric couplers can be qualitatively attributed to their lack of efficiency. Even though the size and location of each actuator captures a significant portion of the strain in the two-stripe mode of a blade, conversion of this strain to electrical energy is limited by the inefficiency of the piezoelectric actuator.

The piezoelectric actuators would be much more beneficial at reducing the blade stresses in a mistuned system if they were used to add damping instead of increasing coupling. Results in the literature indicate that the damping of a very lightly damped engine blade could be easily increased by an order of magnitude with a tuned piezoelectric absorber. Increasing the damping by an order of magnitude reduces blade stresses by the same amount. This stress reduction is much more than could be expected from the elimination of rogue behavior in a mistuned system by increasing the blade-to-blade coupling.

This effort is complete. No additional work is planned for this program.

Participating Organizations: Air Force Research Laboratory (AFRL)

Point of Contact:

Government

Mr. Robert Gordon
 U.S. Air Force, AFRL/VASS
 2145 Fifth Street, Suite 2
 Wright Patterson AFB, OH 45433-7006
 Phone: (937) 255-5200 ext. 402
 Fax: (937) 255-6684
 Email: robert.gordon@wpafb.af.mil

6.1.3 Centrifugally Loaded Viscoelastic Material Characterization Testing FY 96-98

CSA Engineering was tasked to characterize the behavior of viscoelastic material under centrifugal loads. While a great deal of work was done characterizing and measuring the Poisson's ratio of representative viscoelastic material in the laboratory environment, only the results of exposing viscoelastic material to centrifugal loads in a spin test are discussed here. Two types of blades were spun. The purpose of the first type of blade (shown in Fig. 76) was solely to study the effect of quasi-static centrifugal loading on viscoelastic material. The material, cast in a pocket, was subjected to up to 25,000 g's. The predicted strain over the pocket compared well with measured strain.

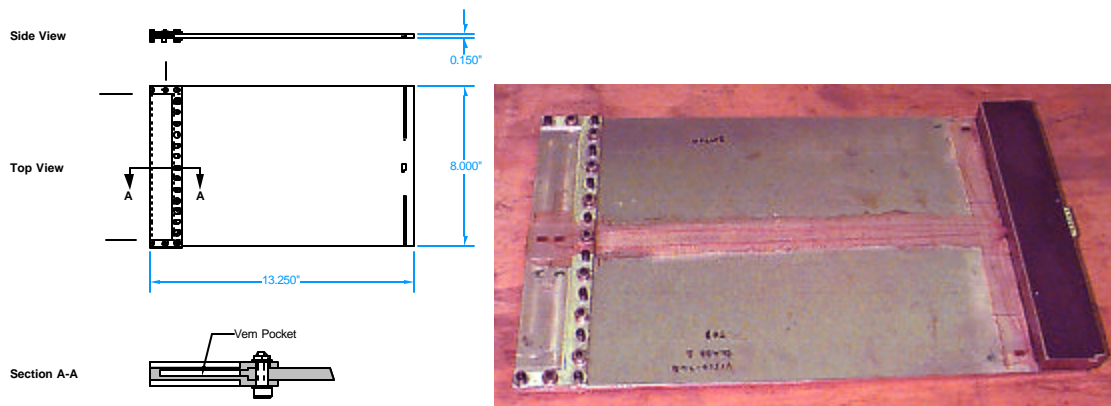

FIGURE 76. Viscoelastic Tub Blade Hardware

The second type of blade was designed to study the issues involved with damping fan blades cost effectively. The developed blade, shown in Figure 77, had a 1.5 aspect ratio. The blade consisted of two face sheets, the thicker of which had two 0.050-inch deep cavities that could be left empty or filled with viscoelastics. The sheets were held together with bolts and epoxy. The blade was instrumented with strain gages and piezoelectric patch (PZT) actuators.

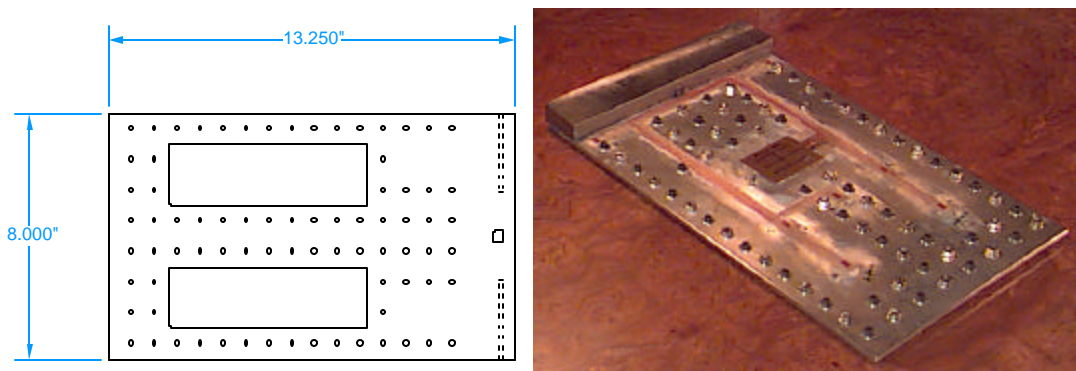

FIGURE 77. Damping Study Blade

The spun blade had one cavity filled with viscoelastic material and one empty cavity. This allowed further study of the effects of quasi-static stress on face sheets containing viscoelastics. A comparison of measured vs. predicted strain is shown in Figure 78. The measured strains for the full cavity are consistently higher than those for the empty one, as predicted. This blade was also exposed to 7,500

RPM, or the equivalent to 22,000 g's at the outmost location of the viscoelastic. The effectiveness of the damping design is seen in laboratory measurements comparing the damped blade and another completely empty but otherwise identical blade (Fig. 79). The targeted higher-order modes, such as those near 400 and 700 Hz, were well damped. Damping would have been even more significant if both pockets had been full.

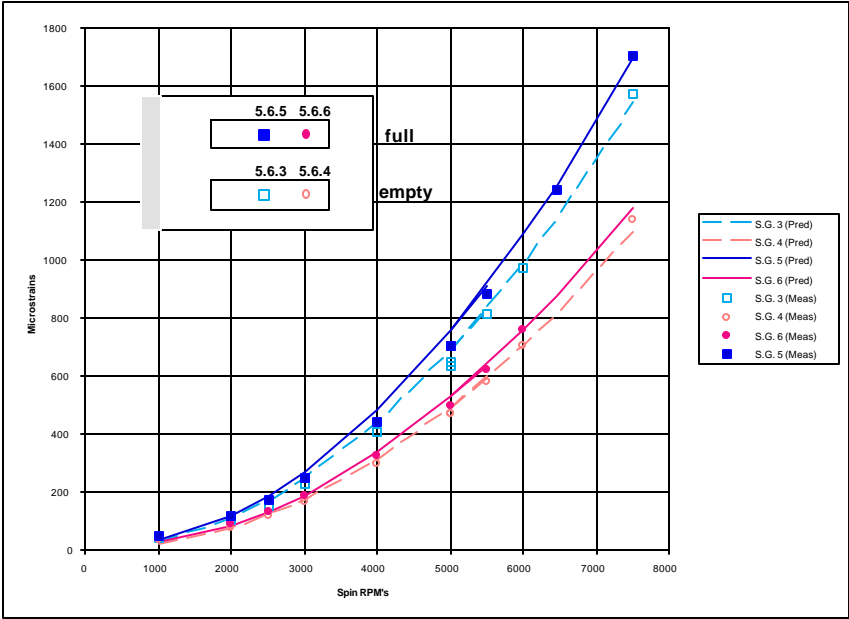

FIGURE 78. Comparison of Measured and Predicted Static Strain Over Cavity Locations for Various RPM Levels Where 7,500 RPM Corresponds to a Maximum of 22,000 g's

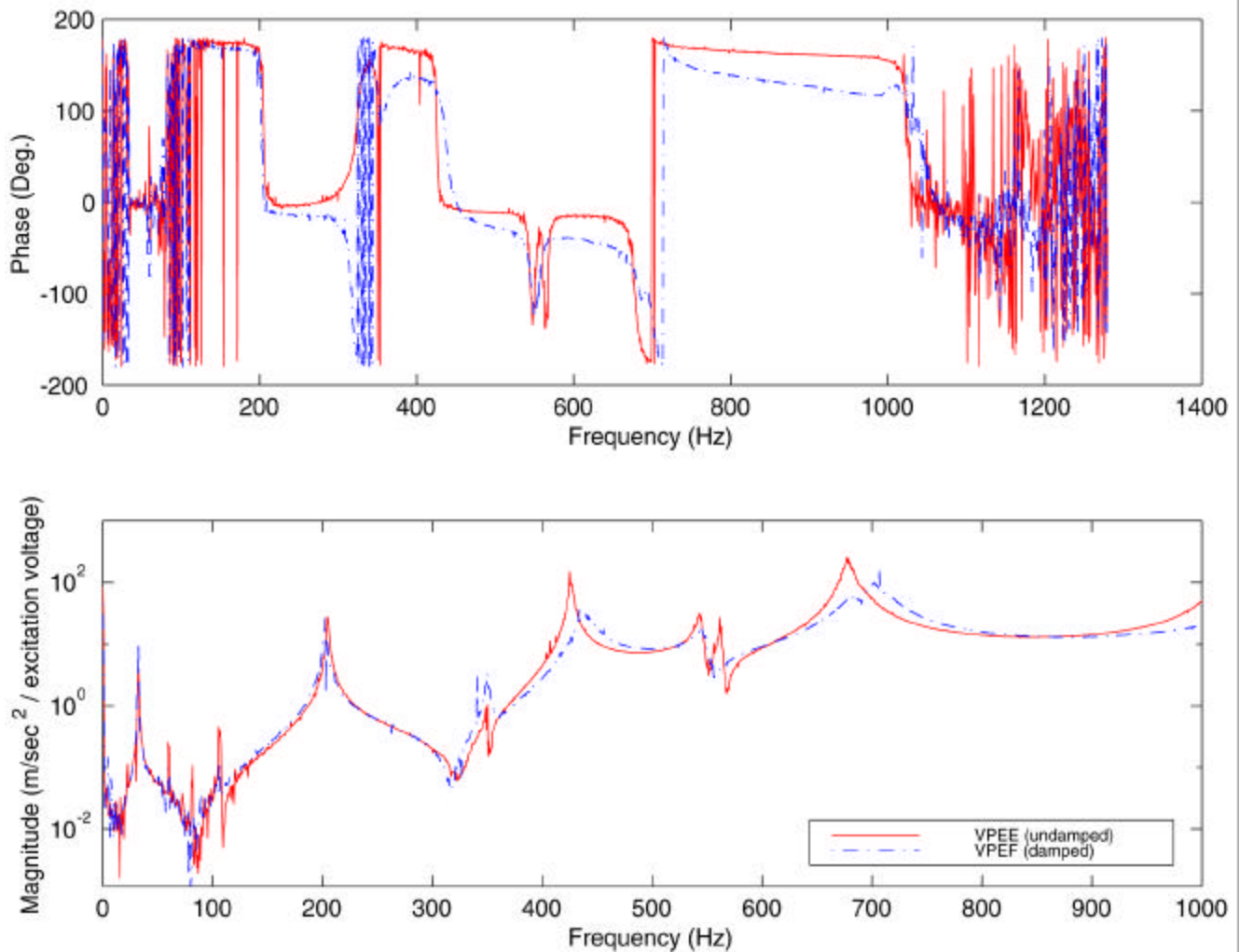

FIGURE 79. Comparison of Undamped and Damped Blade Response (One Pocket) to PZT Excitation in the Laboratory

Participating Organizations: CSA Engineering, Inc.

Points of Contact:

Government

Mr. Robert Gordon
 U.S. Air Force, AFRL/VASS
 2145 Fifth Street, Suite 2
 Wright Patterson AFB, OH 45433-7006
 Phone: (937) 255-5200 ext. 402
 Fax: (937) 255-6684
 Email: robert.gordon@wpafb.af.mil

Contractor

Mr. Eric Flint
 CSA Engineering, Inc.
 2565 Leghorn Street
 Mountain View, CA 94043-1613
 Phone: (650) 210-9000
 Fax: (650) 210-9001
 Email: eflint@csaengineering.com

6.1.4 Damping for Extreme Environments

FY 97-01

Background

Recent results of ongoing studies into the effectiveness and predictability of particle damping are discussed. Effort has concentrated on characterizing and predicting the behavior of a wide range of potential particle materials, shapes, and sizes. Some of the methodologies used to generate data and extract the characteristics of the non-linear damping phenomena are illustrated with interesting test results. Some of these results also are compared to predictions from simulations performed with an explicit code, based on the particle dynamics method, that has been developed in support of this work.

Recent Progress

Figure 80 shows a comparison of preliminary experimental and analytical results. For the damped analyses, the 0.250 inch diameter tungsten carbide sphere was given viscoelastic properties using a three parameter Maxwell model with $E_0=70.0 \times 10^6$ psi, $E_1=44.0 \times 10^6$ psi, and $\tau_1=2.0 \times 10^{-6}$ sec.

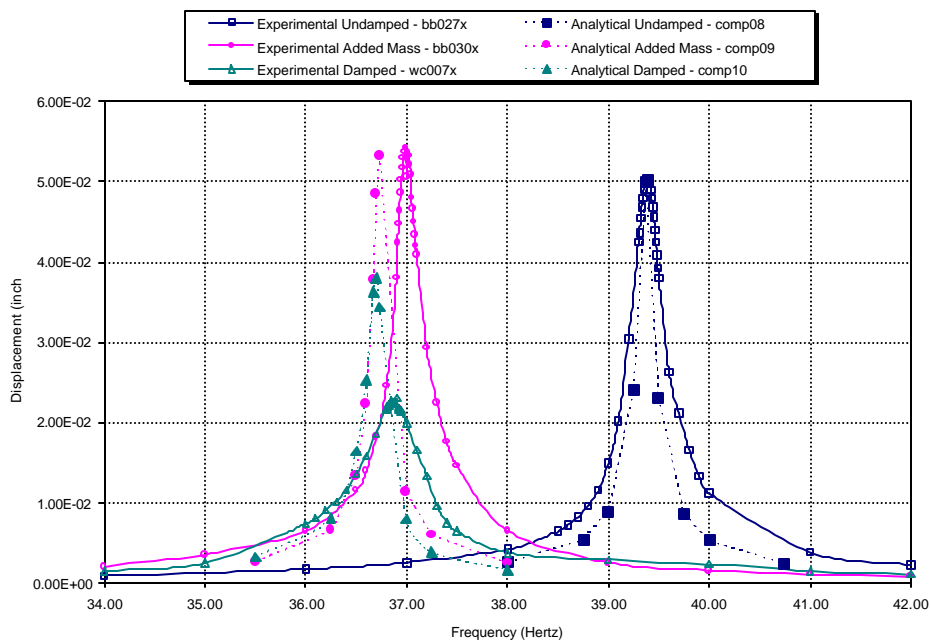

FIGURE 80. Comparison of Experimental and Analytical Results

A method to calculate damping that does not require measuring the input excitation is to measure the sinusoidal ring down of the structure and calculate the slope of the envelope. Ring down data and Hilbert transform curve fit for an undamped beam is shown in Figure 81. Ring down measurements for multiple particles are shown in Figure 82. It is a well-known phenomena that damping from particles may be dependent on amplitude. The change in slope of the curve fit shows the change in damping as the amplitude decreases. The left-hand plot in Figure 82 shows $z=0.0041$ for 80 particles at high amplitude. The right-hand plot in Figure 82 shows $z=0.0068$ within the same test at lower amplitude.

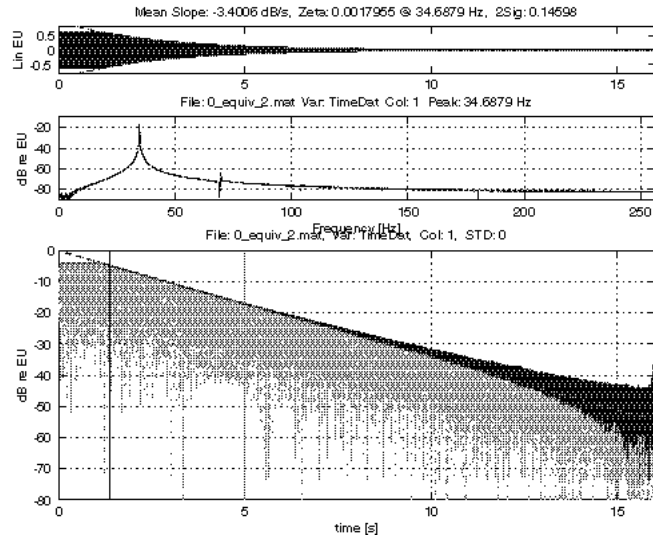

FIGURE 81. Hilbert Transform for Beam with Zero Particles

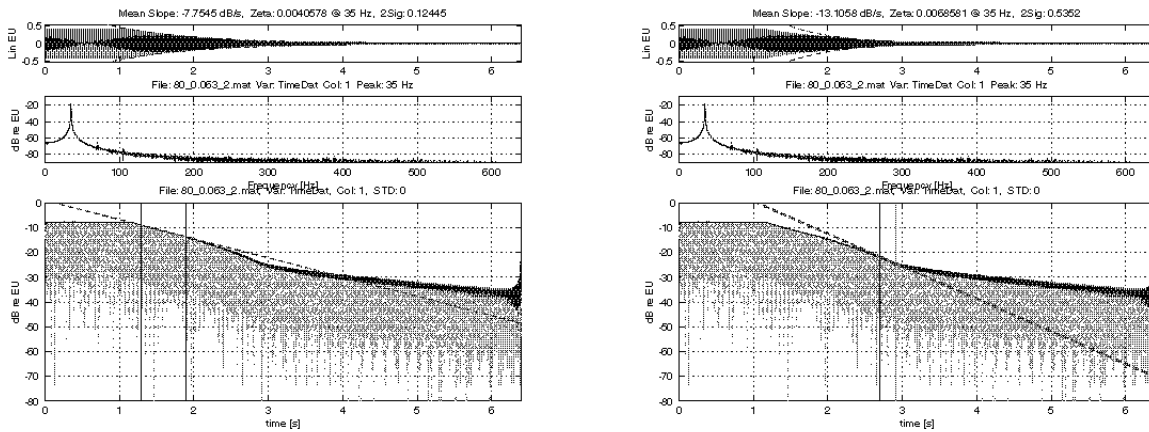

FIGURE 82. Eighty Particles

Application:

Engine hardware for application of the multi-particle impact damping treatment using the design methodology has been selected. The hardware is a divergent flap backstructure subcomponent for the High Speed Civil Transport. The subcomponent is approximately 12 inches by 12 inches by 4 inches high. It has been designed for high-temperature capability and acoustic noise reduction, and is made from gamma-titanium to reduce part weight. Currently, two of these subcomponents exist. One will remain at Pratt & Whitney's acoustic test facility for part set-up and undamped testing. The second part will be provided to CSA Engineering for application of the damping treatment.

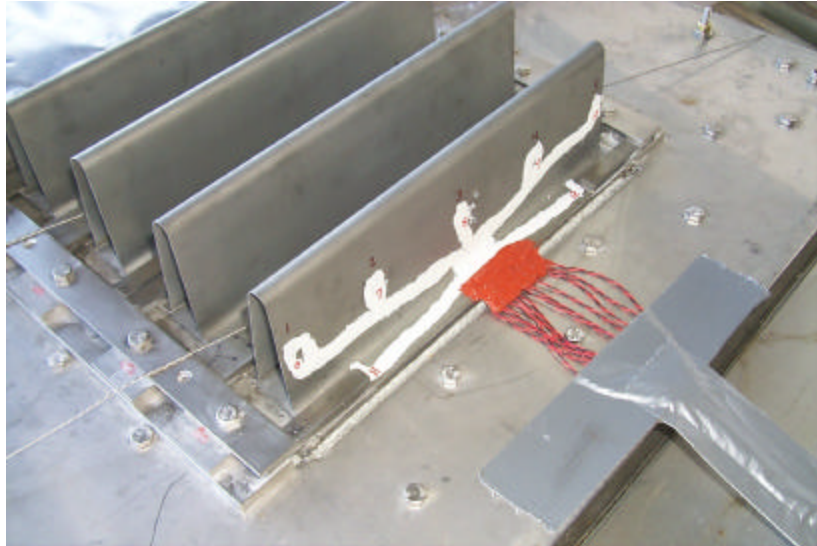

FIGURE 83. Subelement Strain Gage Locations on a Test Specimen



FIGURE 84. Subelement Mounted in Test Fixture

Participating Organizations: CSA Engineering, Inc., University of Dayton Research Institute

Points Of Contact

Government

Mr. Robert Gordon
U.S. Air Force, AFRL/VASS
2145 Fifth Street, Suite 2
Wright-Patterson AFB, OH 45433-7006
Phone: 937-255-5200 ext. 402
Fax: 937-255-6684
Email: Robert.Gordon@wpafb.af.mil

Contractor

Mr. Bryce Fowler
CSA Engineering, Inc.
2565 Leghorn Street
Mountain View, CA 94043-1613
Phone: 650-210-9000
Fax: 650-210-9001
Email: bryce.fowler@csaengineering.com

6.1.5 Centrifugally Loaded Particle Damping

FY 96-01

Background

This work is targeted at determining if particle damping can be a viable damping treatment for military aircraft engine blades despite their high centrifugal loads, and has focused on three primary areas:

- (1) Development of accurate predictive algorithms of particle damping behavior that can account for the centrifugal loads
- (2) Performance of laboratory-based testing of particle damping characteristics of specific interest to the understanding of behavior under centrifugal loads
- (3) Testing of potential candidate damping treatments under centrifugal loads

Recent Progress

Efforts this year have concentrated on the second and third of the following sub-projects.

1. Investigation of Expected Blade Disturbance Levels

While maximum stress in the blade is typically the design quantity of interest, when trying to understand particle damping effectiveness, maximum displacement or acceleration is more critical. Information collected from various sources has shown that aircraft engine blades can experience significant dynamic disturbance levels. Out-of-plane tip acceleration levels have been said to reach levels of as high as 6000 g's. However, the ratio of blade maximum expected response versus applied centrifugal load, while significant, is low, usually below 0.1.

2. Investigation of Low-G Turn-Off Effects

To date, most of the body of work performed on particle damping has concentrated on situations where peak damping and high acceleration ratios were important. Thus, prior to commencing full scale testing of particle damping configurations under centrifugal load, it was deemed important to better understand the effect of applied quasi-static loads on particle damping behavior. An easily available load, earth's gravity field, was used to examine a wide variety of representative combinations of damping material and cavity sizes. Key results are that while there are not many, there are some configurations that show promise of working at low acceleration ratios. These better-performing treatments will soon be tested in the test system described below.

3. Development of a Low-Cost Centrifugal Testing Facility

Efforts in this fiscal year have concentrated primarily on bringing a laboratory grade centrifuge device on line that has been customized to meet the needs of rapid turnaround testing of a wide range of potential particle damping configurations. The fully instrumented test blade is shown integrated in its hub and in its dedicated centrifuge in Figure 85. Baseline tests have been performed to establish the undamped behavior of the test system. Modes stiffen as expected.

Expected Efforts in the Next Year

It is still too soon to conclude whether or not particle damping can be made to work in aircraft engine blades. Preliminary testing of particle damping configurations, using earth's gravity field as a temporary substitute, has revealed some promising potential configurations. In the next year, a series

of detailed tests concentrating on the effect of centrifugal load will be conducted using the described test setup. Efforts will concentrate on qualifying damper concepts that can be transitioned to actual turbine blades based on capsule size and added particle mass. Work in this area is expected to be completed within the next year. Depending on the success of these efforts, other issues may be studied, including wear of both the cavity walls and internal particles under repetitive quasi-static and dynamic loading.

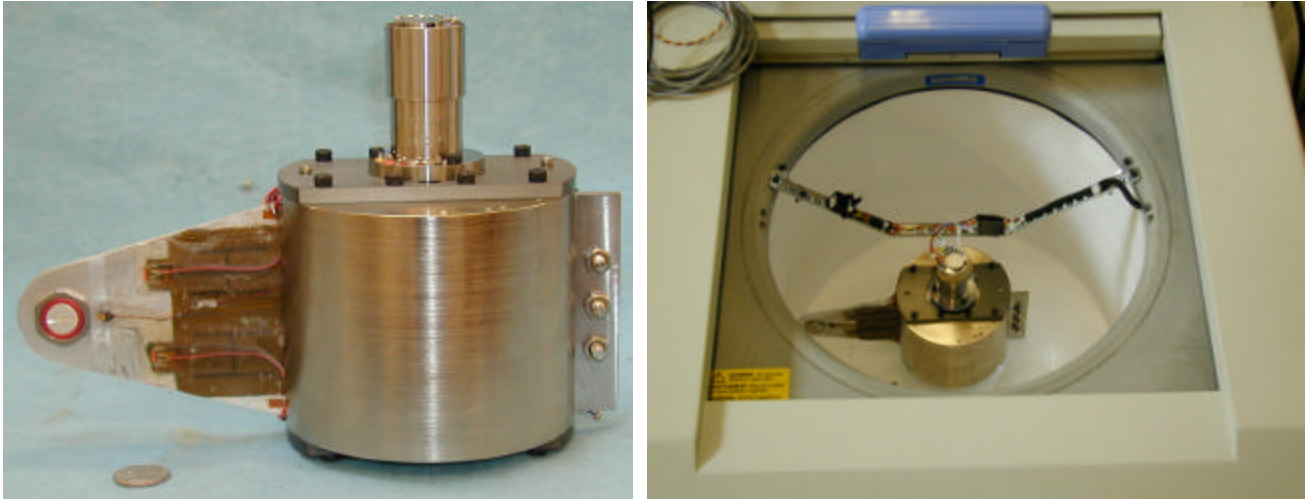

FIGURE 85. Test Blade and Hub by Itself and Installed in Centrifuge

Participating Organizations: CSA Engineering, Inc., University of Dayton Research Institute (UDRI)

Points of Contact:

Government

Mr. Frank Lieghley, Jr.
U.S. Air Force, AFRL/PRTC
1950 Fifth Street, Bldg. 18D
WPAFB, OH 45433-7251
Phone: (937) 255-1867
Fax: (937) 255-2660
Email: frank.lieghley@wpafb.af.mil

Contractor

Mr. Eric Flint
CSA Engineering, Inc.
9500 Gilman Dr 0085
Palo Alto, CA 94303-3843
Phone: (650) 210-9000
Fax: (650) 210-9001
Email: eflint@csaengineering.com

6.1.6 Coatings for Damping Turbine Engine Components

FY 00-01

Background

For several years there have been reports from the turbine engine industry that some plasma sprayed ceramic or metallic coatings can provide vibration damping. The mechanisms for damping have not been identified and no known measurements of the damping properties of these coating materials have been made. Unlike vitreous enamels, these coatings do not have a known wide temperature range over which they soften and exhibit viscoelastic behavior. Potential sources of damping in these coatings might be associated with microcracks or amorphous regions in the microstructure.

Objective: The objective of this investigation is to make quantitative measurements of the damping properties of selected coatings. Further, the dependence of these properties on cyclic strain, temperature, frequency and state of microcracking will be investigated.

Scope: A total of thirty specimens will be fabricated for this testing by a source outside this program. These specimens shall be fabricated from Hastolly X at a thickness of .091". The specimens will be marked for identification. One specimen will be selected to verify the analysis for mode locations and maximum excitation level. From this information, three modes will be selected for the remaining tests. From the thirty specimens, seventeen additional specimens shall be selected. All eighteen specimens will be tested in the uncoated condition according to the attached test matrix. The test results will be cataloged for each specimen. These specimens will be coated. There will be three coatings evaluated at two thicknesses and three specimens for each configuration. The initial testing will be done on two like specimens. The virgin coated test set and the post-thermal cycling test set will be performed on these two specimens. Based on the initial test results, the test matrix will be modified to test the remaining specimens at test conditions that impact the coating damping effectiveness. The remaining twelve specimens will be tested at these sets of conditions. If at any time it is believed, based on the test results, that a different direction may be more advantages than the one selected, the contractor should be informed.

Approach: Coatings will be characterized by measuring the difference in the frequency response of cantilever beams with and without coatings and calculating coating properties. Modified Oberst beam specimens will be used, with the coatings applied to both sides of the cantilever beams. Geometry of the bare beam specimens is shown in Figure 86. The frequency response characteristics of each bare beam will be individually determined as a function of mode, temperature, and strain level. Three (3) different coating materials will be investigated. Thickness of the coatings will be varied. Duplicate specimens will be tested to check for reproducibility. Excitation of the specimen will be sinusoidal. A non-contacting transducer will be used to measure response. It is expected that the damping properties of these coatings may not fit a linear viscoelastic model. Efforts will be made to fit the measured data to a non-linear model, in which the energy dissipated in the coating per cycle is represented by the following equation:

$$D = J \int_{\text{vol}} \mathbf{s}^n$$

where:

D is the energy dissipated per cycle

J and n are material constants (typically $n \geq 2$, can be non-integer)

s is the amplitude of the alternating stress in the coating

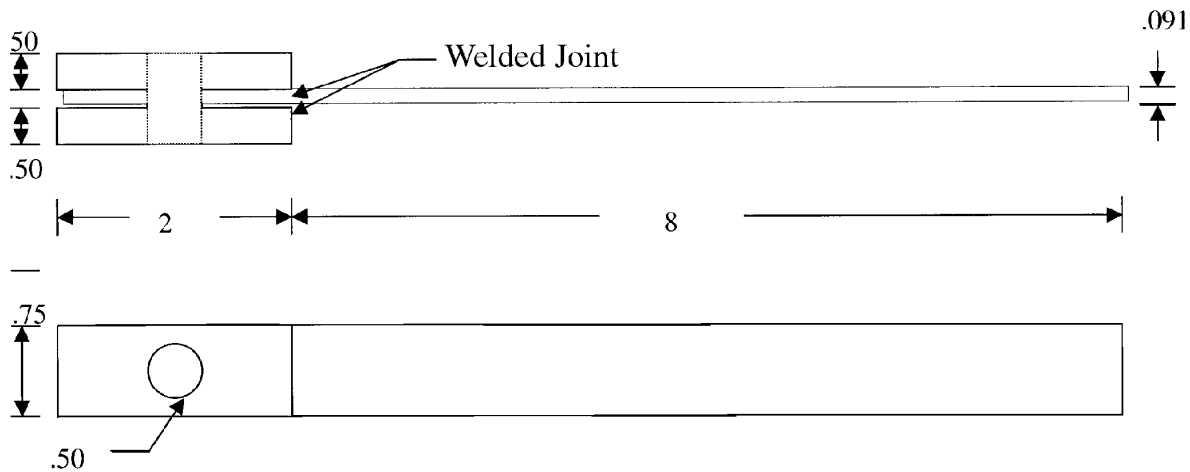

FIGURE 86. Damping Test Specimen

Recent Progress

UTC awarded the contract for this testing effort to Roush Anatrol. Eighteen test beams were delivered to Roush Anatrol for bare beam characterization. The challenge of obtaining high-quality damping measurements on beams, while controlling strain to 500 μ strain at temperatures up to 1,000°F, is greater than anticipated. Roush Anatrol has made progress and is in the process of evaluating bare beam results. Future plans are to coat beams, test the characteristics of the coating, and analytically model the coating.

Participating Organizations: Air Force Research Laboratory (AFRL), Universal Technology Corp.

Points of Contact:

Government

Mr. Robert Gordon
U.S. Air Force, AFRL/VASS
2145 Fifth Street, Suite 2
Wright Patterson AFB, OH 45433-7006
Phone: (937) 255-5200 ext. 402
Fax: (937) 255-6684
Email: robert.gordon@wpafb.af.mil

Contractor

Dr. Jack Henderson
Universal Technology Corp.
1270 N. Fairfield Rd.
Dayton, Oh 45432
Phone: (937) 255-5003
Fax: (937) 429-5683
Email: john.henderson@utcd Dayton.com

6.1.7 Development of Air Film Damping for Turbine Engine Applications

FY 00-03

Background

Prior work performed by Damping Technologies, Inc. has demonstrated that Air Film Damping works well. By this it is meant that the dimensions of an air film can be selected to introduce relatively high levels of damping in chosen modes of vibration of a structure, without adding weight to the structure, without adding any extraneous materials, and without introducing major concerns about high temperatures and centrifugal loads. The basic premise of the Air Film Damping concept involves configuration of an air film gap that is encapsulated by structure, which for resonance response, undergoes deflection and results in movement or "pumping" of the air in the gap. In other words, modal displacements of the structure are forced to pump the air. The flow in the air film appears to be viscous and results in high internal cyclic pressure differences, acting in opposite phase to the local modal velocity, much as occurs with squeeze film dampers in rotating turbomachinery. The difference is that no rotation is involved here, and no special means are needed to maintain the film. Since air is the damping medium, there are no temperature survival limits or effective damping temperature range concerns. The properties of air pertinent to Air Film Damping are reasonably constant across the temperature range from -50°F to 2,000°F. Consequently, damping performance is anticipated to be fairly constant for wide temperature ranges. Since air has little mass, centrifugal loads will not significantly affect it. Relative to durability issues, initial work indicates that although the Air Film Damping mechanism relies on modal participation in "pumping air" via motion in the structure, local dynamics of Air Film Damping System actuation platelets are very heavily damped. Durability issues will require attention, but no excessive durability concerns are anticipated.

During prior and current work, an effective design methodology has been developed for configuration of appropriate Air Film Damping Systems (AFDS). This is important and provides the basis for a new and workable technology to introduce damping into extremely complex and expensive turbine engine components without adding other problems. Prior Phase I SBIR work performed by Damping Technologies, Inc. has determined the effects of various configuration parameters, such as platelet dimensions and position, air gap thickness, mode of vibration, system geometry, temperature, etc. This work has resulted in development of an excellent modeling capability for AFDS. Considerations of the dynamics of the base structure and of the AFDS components will yield specific geometry of the AFDS for which the damping performance can be optimized for specific modes of vibration. The approach involves a multi-dimensional search process to seek optimum damping in each selected mode of vibration by successively varying controllable air film parameters such as location, gap thickness, cover platelet thickness, and film area. Finite element analyses and laboratory vibration tests have shown that for simple vibrating structures, such as flat cantilever beams and plates, appropriately configured AFDS greatly increases the damping in many modes of vibration over a wide frequency range.

Recent Progress

Damping Technologies, Inc. has further developed Air Film Damping technology during the current Phase I program. Tests and analyses have shown that high levels of modal damping can be achieved by means of Air Film Damping for the two-stripe mode of the Allison Advanced Development Co.

(AADC) GMA3007 Type III fan blade. Correlation between finite element (FE) analysis and experiment is very good, with analysis currently being somewhat conservative.

Figure 87 describes a very simplified Air Film Damping System applied to a cantilever beam. Note that for the mode 3 deflection of the beam, there is considerable relative motion between upper and lower surfaces of the air film gap. This modal deflection results in pumping action of the air in the gap. This modal pumping results in viscous flow of the air within the gap and results in damping in mode 3 of the cantilever beam.

The same basic concept is utilized for the Air Film Damping System applied to the AADC GMA3007 Type III fan blade of Figure 88. In the case of the fan blade, the two-stripe mode of vibration near 1750 Hz was targeted for attenuation via an AFDS. The initial design and development iteration concentrated on an external, non-aerodynamic AFDS which could be applied to the surface of the fan blade to demonstrate that significant damping can be introduced into the two-stripe mode of the fan blade using the technology.

Finite element analysis was utilized to model the structural dynamics of the fan blade and to design the Air Film Damping System. Figure 89 describes the predicted frequency response of the AADC GMA3007 TYPE III fan blade with the external AFDS. The model predicts significant damping levels in the two-stripe mode. The Air Film Damping System hardware was consequently fabricated and applied to the fan blade.

Figure 90 describes experimental frequency response measurements acquired on the AADC GMA3007 Type III fan blade with the Air Film Damping System hardware installed. Figure 90 contains two spectra. One spectrum is the frequency response of the fan blade for ambient air pressure. With the AFDS installed, a modal loss factor of 0.050 was measured for the two-stripe mode at ambient air pressure. The second spectrum of Figure 90 is the frequency response of the fan blade in vacuum. This measurement was performed to verify that the significant level of damping measured was due to the Air Film Damping System. As can be seen in Figure 90, when the air is removed from the AFDS gap, the damping is diminished significantly. This is proof that the damping is due to the Air Film Damping System and is not the result of poor part tolerances or installation techniques. Note that when the air is eliminated, the damping is eliminated. Note also that there is good correlation between the damping levels predicted by the FEA model in Figure 89 and the damping levels measured experimentally in Figure 90.

Subsequent work on the current Phase I program will address design and development of a fully aerodynamic version of the Air Film Damping System, which will again target the two-stripe mode of vibration of the GMA3007 TYPE III fan blade.

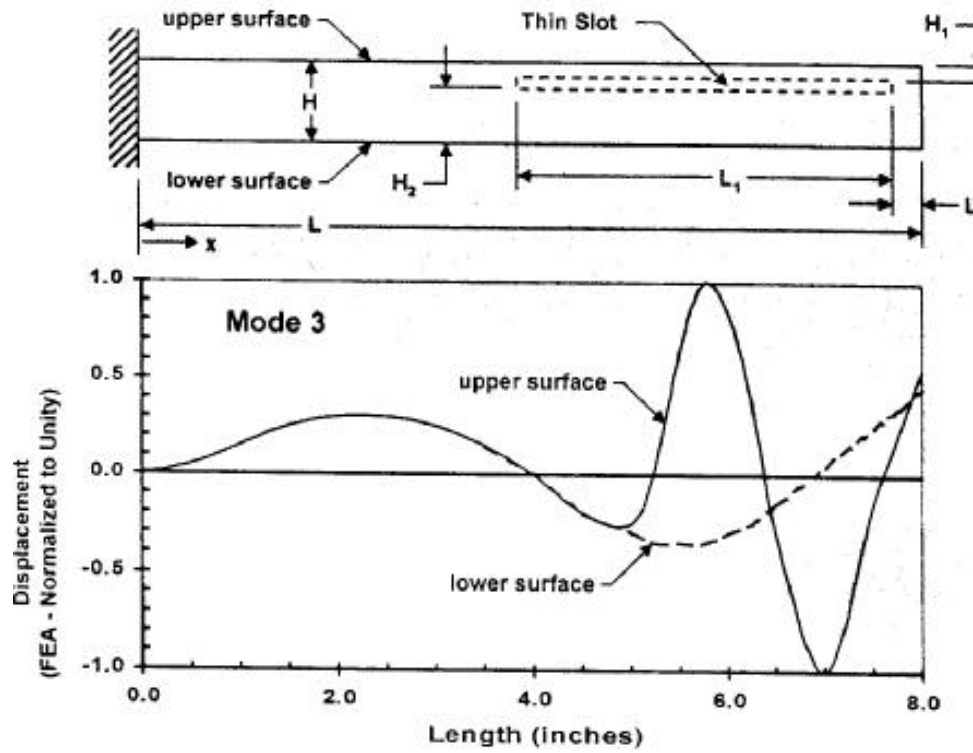

FIGURE 87. Conceptual Drawing of an Air Film Damping System (AFDS) Applied to a Cantilever Beam

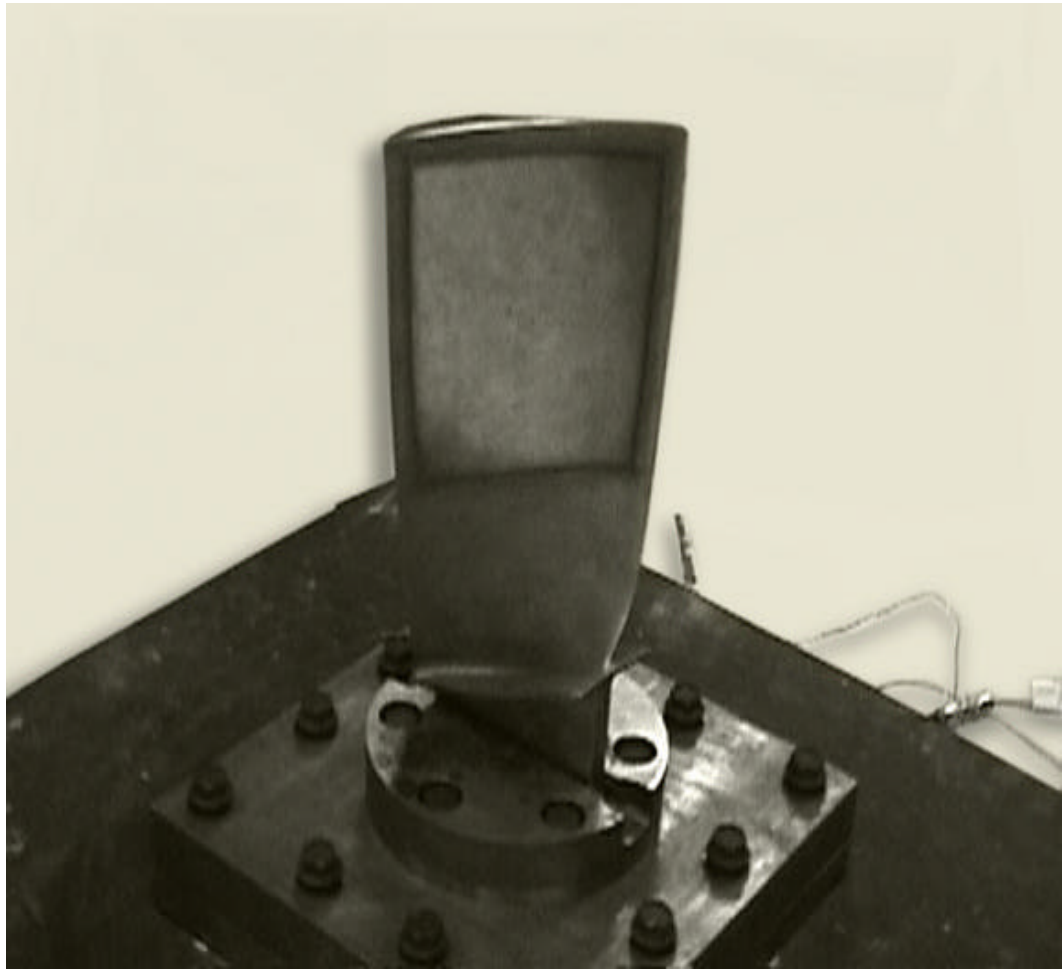

FIGURE 88. External Air Film Damping System Applied to the GMA3007 Type III Fan Blade

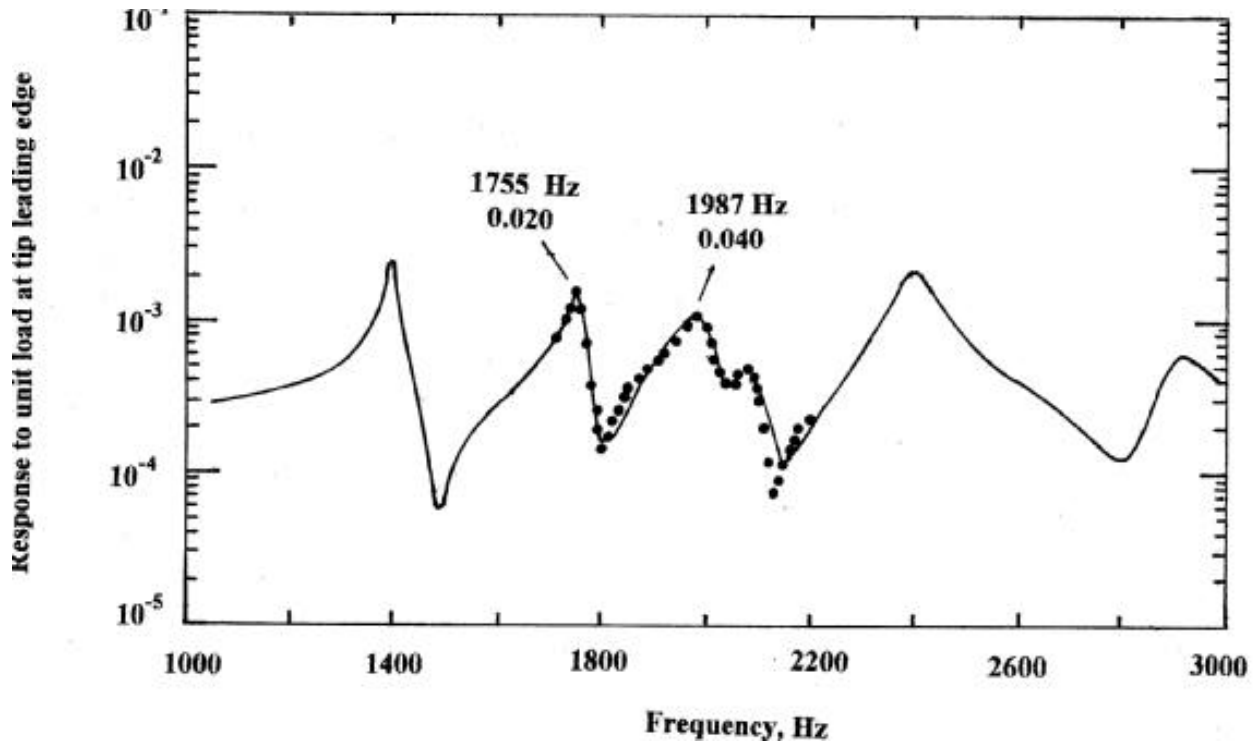
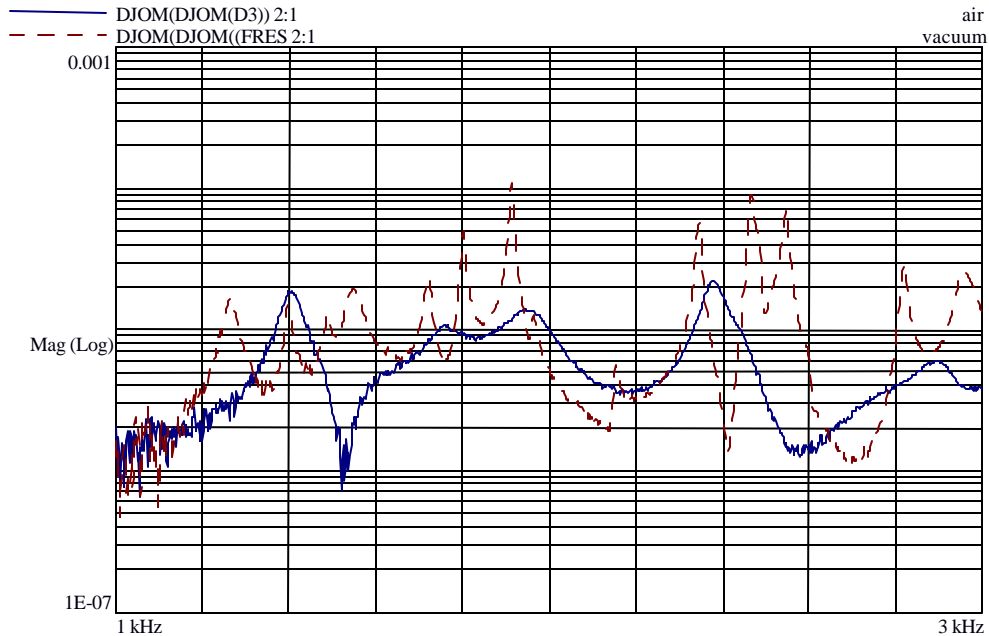

FIGURE 89. Predicted Response (via Finite Element Analysis) of the GMA3007 Type III Fan Blade with the External Titanium Air Film Damping System



^
“Target” 2-Stripe Mode

—————	Ambient Air Pressure	<u>Two-Stripe Mode</u> Loss Factor = 0.050
- - - - -	Vacuum	Loss Factor = 0.0047

FIGURE 90. External Titanium Air Film Damping System Applied to the GMA3007 Type III Fan Blade (Experimental Results) (Note: Y-axis Uncalibrated)

Participating Organizations: Damping Technologies, Inc.

Points of Contact:

Government

Mr. Frank Lieghley, Jr.
 U.S. Air Force, AFRL/PRTC
 1950 Fifth Street, Bldg. 18D
 Wright Patterson AFB, OH 45433-7251
 Phone: (937) 255-1867
 Fax: (937) 255-2660
 Email: frank.lieghley@wpafb.af.mil

Contractor

Mr. Tom Lewis
 Damping Technologies, Inc.
 12970 McKinley Hwy.
 Unit IX
 Mishawaka, IN 46545

6.2 Modeling and Incorporation of Damping in Components

Of the four types of damping systems (friction dampers, viscoelastic damping systems, particle dampers, and powder damping systems), two were ready for use in the design of rotating components: friction and viscoelastic damping systems. A program was initiated to use friction dampers for lower-order modes and to establish their ability to damp higher-order modes. Although there were some concerns with using viscoelastic materials, it was decided that a design program should be started while final characterization of viscoelastic materials was pursued. Component design work for particle and powder damping systems was considered premature, due to a lack of knowledge and a lack of confidence as to the likely performance of either system in a centrifugal environment. Design and testing of components with these systems will occur in the future.

6.2.1 Advanced Damping Concepts for Reduced HCF *FY 96-99*

Background

The objective of this task was to design damping into integrally bladed rotors. The new damped design will be validated with a spin test (see section 6.2.2). Although the original focus of this program was hollow fan blades, the program was redirected toward concepts applicable to both hollow and solid blades. This change occurred because of the increasing reliance of the manufacturers on rotors with solid blades.

Final Results

Information was gathered to define damping level requirements and the operational environment for a damping system. Team members Pratt & Whitney (P&W) and Honeywell Engines and Systems provided environmental definition information, including operating speeds, temperatures, and frequency ranges, to the University of Dayton Research Institute (UDRI). They also provided documentation regarding current and future blade systems and finite element models of typical blade designs.

Based on discussions with the Air Force, the UDRI/P&W/Honeywell team developed a list of damping concepts applicable to rotating bladed turbine engine hardware. A Delphi analysis was used to rate each damping concept. The criteria for the analysis were selected by the team to fairly address the effectiveness, reliability, and manufacturability of each of the concepts. All the evaluation factors were weighted evenly. The results of the Delphi analysis are indicated in Table 4. Based on the assessment, the team and the Air Force decided to pursue detailed design and demonstration of a constraining layer rim damping (CLD) concept.

The rim damping concept will be demonstrated on a P&W Fan integrally bladed rotor (IBR). The target mode is the third leading edge (3LE) bending mode in the blade coupled with the nine-nodal-diameter bending of the rim. Several leading-edge and trailing-rim damping design concepts were developed by UDRI and reviewed by P&W with regard to manufacturability and clearance issues. Based on technical review among the team members, specific changes to the leading edge of the IBR were selected that will allow the damping concept to be applied to a cylindrical surface. For this particular IBR, the trailing edge rim is cylindrical, and no changes were required for attaching the damping concept.

Damping Concept	Existing Technology Knowledge	Ease of Manufacture	Reliability	Transitionability to Existing Designs	Solves Mistuning Problems	Solves High-Frequency Resonance Problems	Solves Flutter and Surge Problems	No Performance Impact	Capability to Meet Environ. Conditions	Raw Score	Ranking
Constraining Layer Rim Damping	4	4	4	4	3	1	4	5	3	32	1
Rim Friction Damping	3	4	3	4	3	1	4	5	5	32	1
Damping Pocket With Cover Plate	4	3	3	3	3	2	4	4	3	29	2
Cast Damping Into Airfoil Cavities	4	2	3	1	4	4	4	5	3	29	2
Leading/Trailing Edge Sheathing	3	2	2	3	4	4	4	3	3	28	2
Rim Piezoelectric Damping	2	4	2	4	3	1	4	5	3	28	2
Particle Damping	2	3	3	3	3	1	4	4	5	28	2
Surface Coatings	2	3	2	3	3	4	4	2	3	26	3

Scale: 5=Excellent to 0=Bad

TABLE 4. Delphi Analysis of Damping Concepts

A finite element analysis (FEA) model of the IBR, which had previously been validated by P&W, was modified by UDRI to simulate the addition of a damping system. The FEA was used to evaluate two general conditions: expected effectiveness in damping vibrations and expected ability to withstand centrifugal loads. First, resonant frequency computations were performed over a range of viscoelastic material shear stiffness values. These analyses were used to optimize the strain energy ratio as a function of viscoelastic material shear stiffness for the 3LE bending mode. Time and temperature data provided by P&W indicates that the optimal damping temperature should be 225°F for this IBR, and the survival temperature is 600°F. Because of the 375°F difference between operating temperature and survival temperature, a material like silicone will be needed to handle the temperature range. Unfortunately, silicone has a relatively low inherent material loss factor, on the order of 0.1. To obtain a significant damping level for the 3LE bend mode, the stiffness of the viscoelastic in the CLD system has been optimized to range where the CLD operates as a tuned damper, resulting in a large portion of the system strain energy being transferred into the viscoelastic. Efforts are ongoing to formulate a silicone that has the desired stiffness, temperature capabilities, and creep resistance.

Another issue is the stresses under centrifugal loading. The FEA indicates that steady stress levels in the most highly loaded areas are nearly unaffected by the addition of the damping system. However, the analysis indicates that a damping system with many segments is required to ensure acceptable strain levels in the viscoelastic due to radial growth of the rim under centrifugal loads. To reduce strain in the viscoelastic material under centrifugal loading, the titanium cover, which is acting as a mass for a tuned damper rather than as a typical constraining layer, will be segmented into pieces around the circumference of the rim.

The details of the demonstration of the VEM rim damping system designed and developed under this program are laid out in section 6.2.2 of this report.

Participating Organizations: University of Dayton Research Institute, Pratt & Whitney, Honeywell Engines and Systems

Points of Contact:

Government

Mr. Frank Lieghley, Jr.
U.S. Air Force, AFRL/PRTC
1950 Fifth Street, Bldg. 18D
Wright Patterson AFB, OH 45433-7251
Phone: (937) 255-1867
Fax: (937) 255-2660
Email: frank.lieghley@wpafb.af.mil

Contractor

Mr. Michael Drake
University of Dayton Research Institute, Inc.
300 College Park Av.
Dayton, OH 45469-4251
Phone: (937) 229-2654
Fax: (937) 229-4251
Email: drakeml@udri.udayton.edu

6.2.2 Evaluation of Reinforced Swept Airfoils / Internal Dampers *FY 96-01*

Background

The objective of this project was to develop and spin test a friction damper for fans. The internal friction damper was designed and analyzed to maximize the damping characteristics of this damping system. The primary function of this design was to demonstrate its effectiveness in reducing the vibratory responses of selected high-order modes. A finite element design utilizing the friction damper was completed, a damping prediction analysis was performed on the component, and the analytical model was verified with static bench test data.

Recent Developments

The spin test was cancelled when it was determined that the likelihood of this component ever being placed into production was very limited. It was decided to redirect the program to address damping of integrally bladed rotors (IBRs). It has been aligned with the UDRI task on "Advanced Damping Concepts for Reduced HCF" (see Section 6.2.1). The selected approach has been narrowed down to under-rim viscoelastic damping treatment.

Preliminary testing of this approach on a solid fan IBR has demonstrated good potential for modes with sufficient rim strain energy contribution. Concept demonstration of bench testing of the IBR in a third-leading-edge bending mode resulted in a 20% reduction in response. This approach will be optimized for the real engine environment. Damping assessments will be demonstrated using bench testing only since the centrifugal loading will be designed to be perpendicular to the damping treatment. Survivability testing, however, will be demonstrated in a heated spin test facility. Upon completion of the spin tests, a repeat of the bench damping tests will be conducted to ensure that damping effectiveness still exists after exposure to the elevated temperature spin test.

A fan integrally bladed rotor (IBR) has been modified to receive three under-rim viscoelastic dampers. Undamped/heated bench testing of a the IBR will occur in the Pratt & Whitney Applied Mechanics laboratory in the first quarter of calendar year 2001. In the early spring of 2001, the dampers will be applied at the University of Dayton Research Institute's Aerospace Mechanics Division. Damped bench and spin pit testing is scheduled for April 2001. Project completion is projected for July 2001.

Participating Organizations: Air Force Research Laboratory (AFRL), Pratt & Whitney

Points of Contact:

Government

Mr. Jeffrey M. Brown
U.S. Air Force, AFRL/PRTC
Wright-Patterson AFB, OH 45433-7251
Phone: (937) 255-2734
Fax: (937) 255-2660
Email: jeffrey.brown@wpafb.af.mil

Contractor

Dr. Yehia El-Aini
Pratt & Whitney
P.O. Box 109600, West Palm Beach, FL 33410
Phone: (561) 796-5911
Fax: (561) 796-3637
Email: elainiye@pwfl.com

6.2.3 Damping System for the Integrated High Performance Turbine Engine Technology (IHPTET) Program

FY 97-01

Background

Under this effort, two passive damping systems were designed, manufactured, and spin tested. The goal is to achieve effective magnification factors (Q) of 50 or less for the targeted modes of vibration. Particular emphasis was placed on developing damping systems that are as near production-ready as possible. The damping systems must be effective and reliable under the static loads, the dynamic loads, and the temperature extremes produced in real turbine engine environments. To these ends, the designs are being driven by practical manufacturing and durability considerations. This report focuses on progress made in 2000, the final year of the effort.

In Phase I, the two selected damping designs were a viscoelastic constrained layer system (CLDS) and a non-obstructive particle damping (NOPD) system. As reported last year, a spin test was completed of the NOPD concept, which was applied to hollow flat plate test articles. Although high levels of damping were measured in bench testing, the results from spin testing were disappointing. Therefore, the particle damping concept was eliminated from this program. When the CLDS system was spin tested, the coversheet welds failed. This was also described in last year's report.

In Phase II, a second CLDS system was designed and fabricated into AE3007 fan blades. The remainder of this report documents the Phase II progress through September of 2000.

Recent Progress

Design

AV3099 was selected as the VEM material. Of the materials investigated, AV3099 has the following characteristics:

1. Highest loss factor
2. Highest rubbery modulus (limited data)
3. Co-cures well with epoxy (reference Biggerstaff papers on UCSD website)
4. No apparent solvents.

In support of the design effort, a number of tests were conducted. Double lap shear specimens (0.004 inches thick) were created to gain additional material data. The resulting shear moduli, maximum shear stresses, and maximum shear strains are shown in Figures 91, 92, and 93, respectively. These

results indicate that the shear modulus and maximum shear strength are an order of magnitude below what was expected, and that the maximum shear strain is significantly higher than expected. Additional specimens were used for creep testing (5 psi for 20 minutes). The results of these tests are shown in Figure 94. Interestingly, the amount of creep appears to decrease with increasing temperature.

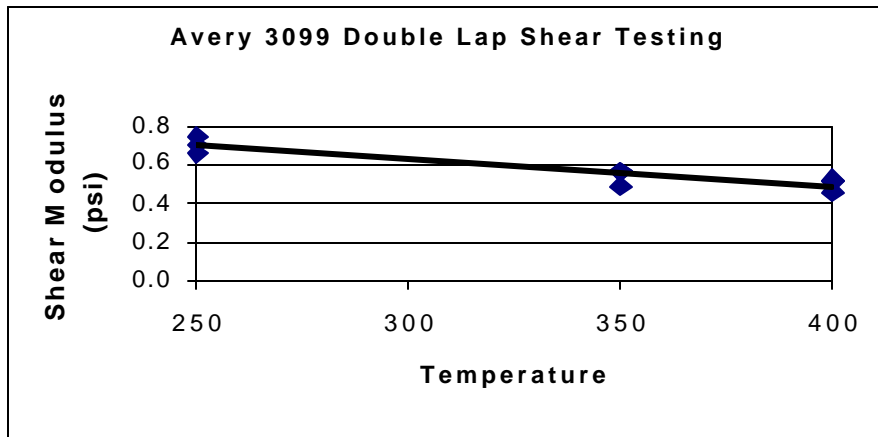

FIGURE 91. Shear Modulus

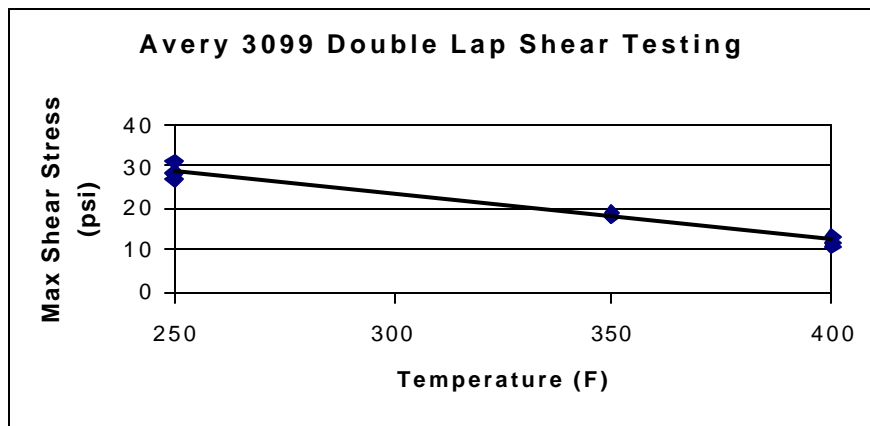

FIGURE 92. Shear Stress

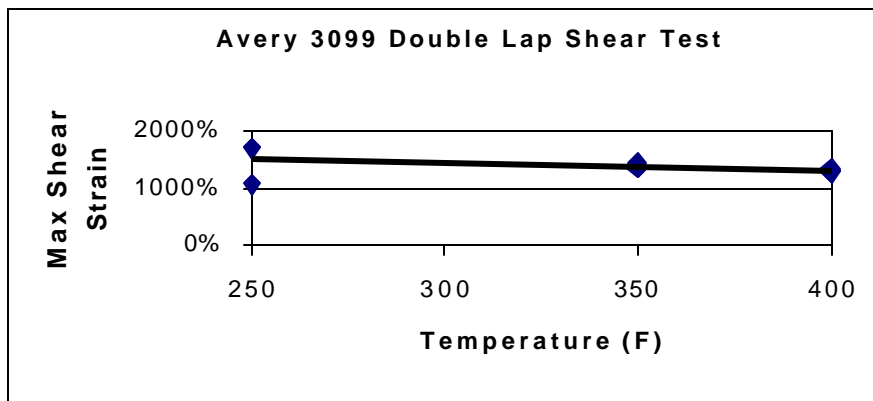

FIGURE 93. Shear Strain

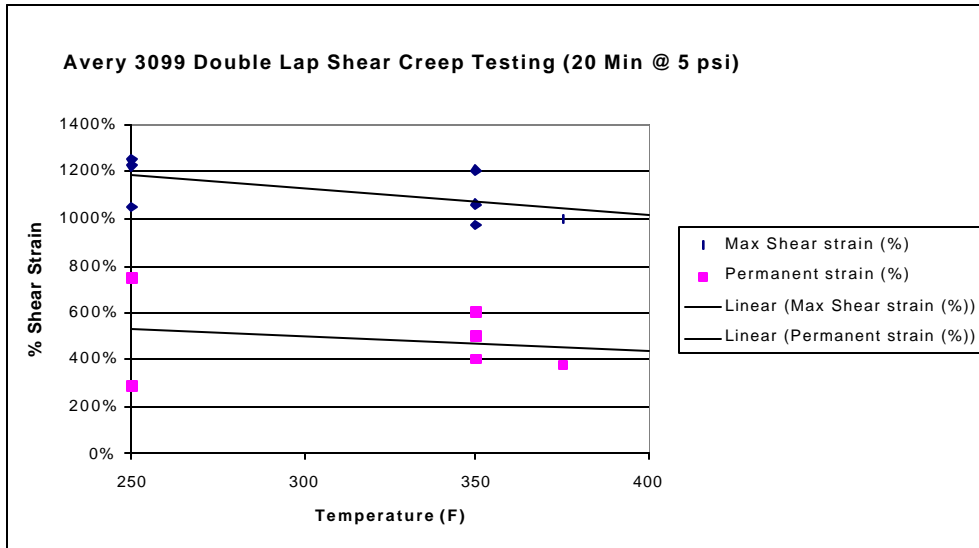

FIGURE 94. Creep Test Results

A spin test of the damping concept was also conducted. The purpose of this test was to demonstrate the ability of the damping design to withstand the required centrifugal loads. Two representative constraining layers were applied to a flat plate and spun to 43,000 g's for 40 minutes. Photographs of the assembly and a close-up of the installed constraining layer are shown in Figures 95 and 96. Post-test inspection revealed that the damping system appeared unaffected.



FIGURE 95. Flat Plate Spin-Test Assembly

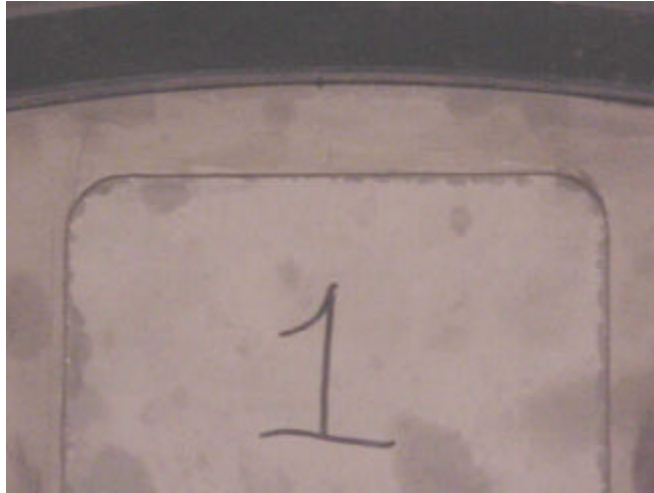

FIGURE 96. Simulated Constraining Layer

Fabrication

Pockets were Electro-Discharge Machined (EDM'd) into six blades by Meyer Tool. An example is shown in Figure 97. The blade pockets were then shot-peened by GEAE.

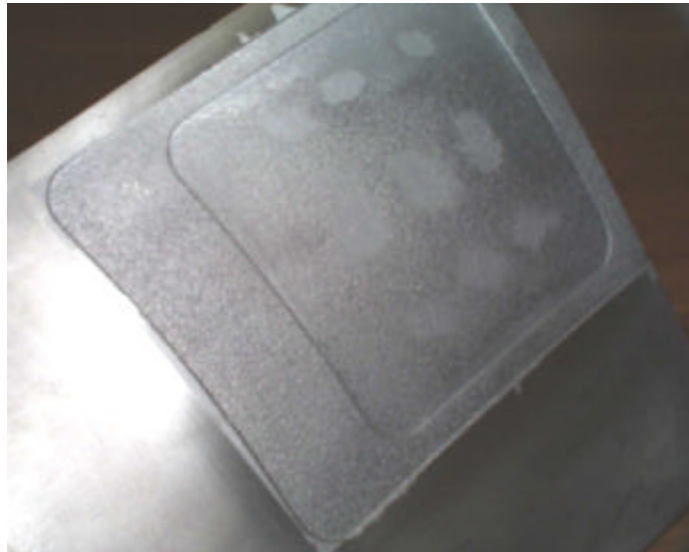

FIGURE 97. AE3007 Blade after Pocket EDM

The fabrication and installation sequence was:

- Using a blade as a template, cut cover sheet, and constraining layer
- Hand bend damper sheets to airfoil contour
- .001" acid etch blade pocket, cover sheet, and constraining layer
- Primer blade pocket, cover sheet, and constraining layer
- Vacuum bag and autoclave at 350°F (single-step cure adhesive to both cover and constraining layer)

A photograph of the first completed blade is shown in Figure 98. Various views of the fifth blade are shown in Figures 99, 100 and 101.

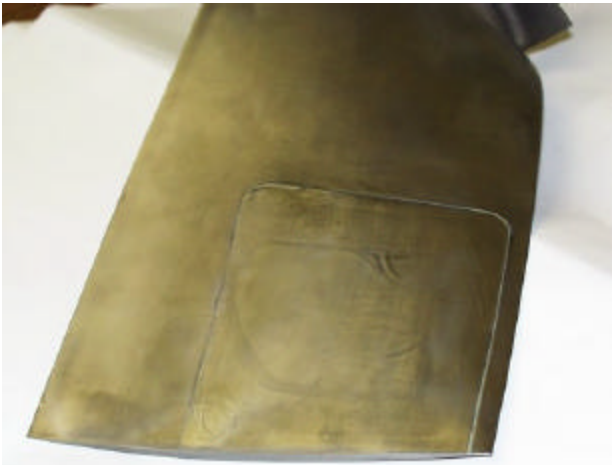

FIGURE 98. Blade 1 with Damping System Installed



FIGURE 99. Blade 5 with Damping System Installed



FIGURE 100. Blade 5 Damping System

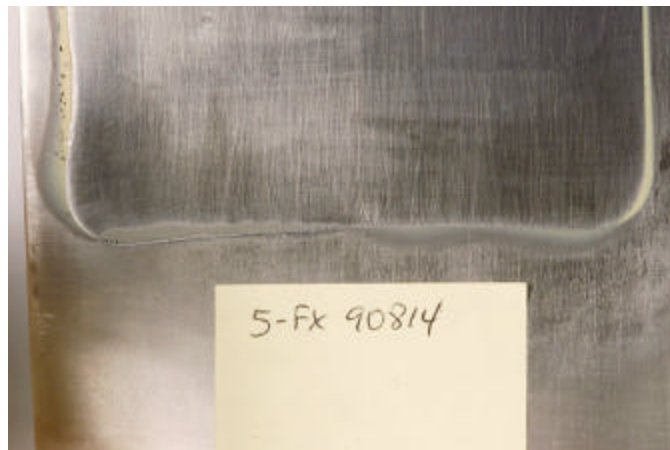

FIGURE 101. Blade 5 Zoomed View of Inner Region

After damper installation, the six damped blades were visually inspected and photographed. The Air Force is investigating the possibility of conducting ultrasonic inspections.

Bench Tests

The primary objective is to measure the modal damping of eight blades, which are to be bench tested over a frequency range of 0 to 2 KHz and over a temperature range from room temperature to 350°F. The bench test specifications are as follows:

Number of blades: 8 total (6 damped, 2 undamped; 1 of the undamped blades will have strain gages and leads installed)

Fixture: To be provided by Allison Advanced Development Company (AADC)

Instrumentation: Capable of measuring vibratory frequency and response level sufficient to calculate modal damping. The instrumentation should not add any significant damping.

Temperature: Bench test the blades at 7 isothermal temperatures (Room temp, 100, 150, 200, 250, 300, 350°F)

Primary Modes of Interest: 2S (1500 Hz), 1T (600 Hz)

Excitation: It is desired to excite the blade to at least 3 Ksida (resonant response) at the maximum strain location.

Spin Test

Test Devices reviewed data involving the AE3007 fan as well as data from the first ACCS test. Both of these tests used a fence excitation system. The conclusion was that fence excitation will be adequate for the planned damped blade testing. A visit was made to Test Devices to inspect the test facility, and to coordinate the instrumentation and test plans. The spin test was completed in November 2000. Preliminary data analysis has shown that the testing was successful and that technology is very promising.

Participating Organizations: General Electric Aircraft Engines, Rolls-Royce, Roush Anatrol

Points of Contact:

Government

Mr. Frank Lieghley, Jr.
U.S. Air Force, AFRL/PRTC
1950 Fifth Street, Bldg. 18D
Wright Patterson AFB, OH 45433-7251
Phone: (937) 255-1867
Fax: (937) 255-2660
Email: frank.lieghley@wpafb.af.mil

Contractor

Dr. Robert E. Kielb
General Electric Aircraft Engines
One Neumann Way, M/D K105
Cincinnati, OH 45215-1988
Phone: (513) 243-2821
Fax: (513) 243-8091
Email: Robert.Kielb@ae.ge.com

6.2.4 Damping for Turbines

FY 97-01

Background

The objective of this project is to develop alternate friction damping systems for turbine blades. The program will also be used to evaluate the potential for advanced blade excitation systems to provide durability data on advanced damping configurations. This will be achieved by spin testing at the Naval Postgraduate School Turbopropulsion laboratory.

Advanced program requirements dictate alternative solutions to damping of turbine blades. Improvements in platform damping and internal damping are being pursued to allow higher aspect ratio blading. These approaches to damping will provide increased design space, providing more-optimal blade and turbine stage designs. The design and calibration of advanced codes is key to the introduction of these advanced concepts into tomorrow's engines.

Vital to the insertion of these technologies into advanced configurations is providing a means to not only evaluate the effectiveness of various damping configurations in a spin environment, but almost equally as important is to establish a configuration's durability limits. What is needed is a means to provide a first look at a new system, which will test at resonance dwells with blade and damper configurations. This will establish engine life limits and ultimately reduce risk of insertion of new configurations.

Recent Progress

A unique internal damper, currently applied to turbine blades, has demonstrated excellent damping of complex high frequency modes of vibration. This technology is enabling and allowed the recent success of a vaneless low-pressure turbine (LPT) engine test (XTE66/1). The removal of the interstage vane in this engine created a potent driver: a shock off the turbine (HPT) blade, as compared to conventional wake deficits formed behind vanes. This damping technology will enable future vaneless configuration designs to become viable by lowering LPT blade stress response in this harsher environment. With further development, the damping technology can be generally used to optimize reduced-weight rotors and engine systems.

The plan for fiscal year 2001 includes generation of data to further calibrate Pratt & Whitney's microslip damping code. The development of advanced damping concepts and the improvement in predictive capability is a key to enabling advanced turbine configurations. In concert with this testing, the demonstration of new blade excitation systems for spin testing is vital to establishing a means of evaluating the long-term durability of advanced damping concepts. The data from this program will be invaluable to the Air Force Dual Use Program which will be responsible for maturing damper concepts by providing durability development using these spin testing methodologies. The success of the Dual Use program is critical to the risk mitigation for JSF Low Pressure Turbine designs.

Participating Organizations: Pratt & Whitney, Naval Postgraduate School (NPS)

Points of Contact:

Government

Mr. John Warren
Naval Air Warfare Center
Bldg. 106, Unit #4
22195 Elmer Rd.
Patuxent River, MD 20670-1534
Phone: (301) 757-0466
Fax: (301) 757-0562
Email: WarrenJR@navair.navy.mil

Contractor

Mr. Al Stoner
Pratt & Whitney
M/S Ave. C
1306 Ave. C
Arnold AFB, TN 37389-4700
Phone: (931) 454-7591
Fax: (931) 454-0504
Email: stonera@pwfl.com

6.2.5 Dual Use Program

FY 01-03

Background

This program will provide damping improvements required to support advanced engine configurations. This will be accomplished by using rapid casting hardware fabrication techniques to generate rig hardware. The development of a verification method relying on rapid prototyping will reduce technology development cycle times. By providing designs rapidly, technology and innovation can be more readily proved out. This will allow marked progress toward improving damping, and delivering designs that meet program goals or requirements. It is not enough to develop new concepts, but these must be fully integrated into advanced cooled turbine blades. The key to developing advanced damping approaches is marrying the damper and blade design to the manufacturing process.

Recent Progress

The contract was awarded very recently. Spin pit test articles have been designed and spin pit tests are scheduled for 2001 at the Naval Postgraduate School and NASA Glenn.

Participating Organizations: Air Force Research Laboratory (AFRL), Pratt & Whitney Aircraft

Points of Contact:

Government

Mr. Frank Lieghley, Jr.
U.S. Air Force, AFRL/PRTC
1950 Fifth Street, Bldg. 18D
Wright Patterson AFB, OH 45433-7251
Phone: (937) 255-1867
Fax: (937) 255-2660
Email: frank.lieghley@wpafb.af.mil

Contractor

Mr. Al Stoner
Pratt & Whitney
M/S Ave. C
1306 Ave. C
Arnold AFB, TN 37389-4700
Phone: (931) 454-7591
Fax: (931) 454-0504
Email: stonera@pwfl.com

6.2.6 Transition of Damping Technology to Counterrotating Low-Pressure Turbine Blades

FY 00-01

Background

Counterrotating turbine designs subject the low-pressure turbine (LPT) blades to high-frequency excitation from the high-pressure turbine blades immediately upstream. The vibratory response of the LPT blades is in a high-order airfoil mode for which typical platform friction dampers used for lower modes are less effective. Damping performance of some HT coatings will be determined to identify potential treatments for these higher-order modes.

The Contract consists of two tasks. In Task 1, simple test specimens with two different damping treatments are being provided to the Air Force for elevated temperature testing. The Turbine Engine Fatigue Facility (TEFF) at the U.S. Air Force Research Laboratory will contrast damping performance of the two treatments for selected airfoil modes of vibration with untreated baseline specimens. In Task 2, a preferred damping treatment will be selected, based on the Task 1 test results, and applied to prototype LPT blades. These blades will then be tested at elevated temperature at the U.S. Air Force TEFF.

Recent Progress

A simple cantilevered plate design was selected for the single crystal nickel test specimen. The specimen test section is approximately 3 inches long, 1.8 inches wide, and 0.1 inches thick. This places selected stripe modes at approximately 5 and 10 KHz. The 5 KHz 1-2s mode is shown in Figure 102 below.



FIGURE 102. The 5 KHz 1-2s Mode of a Simple Cantilevered Plate

Damping analysis was initially completed by Roush Anatrol for several candidate enamel coatings. However, additional information concerning high temperature enamel material properties ultimately led to the decision to drop the enamels from further consideration for this test program. The intent of

the test program is to determine damping properties in the 1600-1800°F temperature range. Enamels may remain a potential damping treatment for less severe elevated temperature service below 1600°F.

Two coatings were subsequently selected for test. The first coating is a GE thermal barrier coating (TBC). The purpose of this selection is to characterize the inherent damping properties of the TBC placed on LP turbine blades for thermal design reasons rather than damping per se. The second coating selected is a hard coating from Allison Advanced Development Company (AADC). Three specimens with each coating and two uncoated baseline specimens were provided to the Air Force for testing in TEFF.

Participating Organizations: GE Aircraft Engines, Allison Advanced Development Company (AADC), Roush Anatrol

Points of Contact:

Government

Mr. Frank Lieghley, Jr.
U.S. Air Force, AFRL/PRTC
1950 Fifth Street, Bldg. 18D
Wright Patterson AFB, OH 45433-7251
Phone: (937) 255-1867
Fax: (937) 255-2660
Email: frank.lieghley@wpafb.af.mil

Contractor

Mr. James A. Griffiths
General Electric Aircraft Engines
One Neumann Way, M/D A413
Cincinnati, OH 45215-6301
Phone: (513) 243-2770
Fax: (513) 243-8091
Email: james.griffiths@ae.ge.com

6.3 Affordable Damped Components

FY 02 - 06

A manufacturing technology program has been developed to bring the cost of demonstrated damped components down to affordable levels. Toll gates have been setup, which each damping system must pass before they will be considered for this program. The program will start in late fiscal year 2002 or early fiscal year 2003.

Participating Organizations: TBD

Points of Contact:

Government

Mr. Glen Ormbrek
U.S. Air Force
AFRL/MLMP Bldg 653
2977 P Street, Suite 6
Wright Patterson AFB OH 45433-7739
Phone: 937-904-4391
Fax: 937-656-4420
Email: schmidtlr@navair.navy.mil

Contractor

TBD

6.4 Conclusion

By conducting rig, component, and engine tests, and by developing very successful modeling techniques, the Passive Damping Technology Action Team has evaluated numerous damping schemes with great potential. The Team has demonstrated that the historically-based “rainbow” or mixed wheel concept is not an acceptable test protocol for HCF modal damping investigation, and that designing a viscoelastic damping system insertion into a mechanically sound rotating blade may be more difficult than it appears. This team has also demonstrated the feasibility of applying viscoelastic damping to the rim of a bladed rotor rather than to the blade surface. Doing so could effect an 80% reduction in blade stresses. Completed initial tests of an internal “dip stick” friction damper for turbine blades also demonstrated up to 80% stress reduction. The turbine friction damping effort has been a major success, with test results showing vibratory reductions much greater than predicted. The turbine damper is currently being applied in an advanced engine development program. Manufacturability of damping solutions is being evaluated as a major area of future emphasis. Significant strides have been made in the modeling of particle damping systems. A redesign of a VEM damping system has been completed and fan blades modified. Preliminary bench tests have been performed. The damped and undamped blades are ready for spin testing.

7.0 ENGINE DEMONSTRATION



BACKGROUND

The Engine Demonstration Action Team (Engine Demo AT) has the responsibility of coordinating all the emerging HCF technologies with planned engine demonstrator targets. The engine demonstrations are responsible for acquiring the necessary data to establish, or update, the design space for the specific emerging HCF technologies so that the technology can then transition to meet user mission-specific requirements. The technology action teams will develop their specific HCF technologies to an acceptable level of risk to run on a demonstrator engine. Initial engine demonstrator planning was based on the original set of HCF technologies that was approved, and is constantly being updated as the budget and technologies change. The Demo AT has been concentrating on the turbojet/turbofan fighter engine class, which includes IHPTET demonstrator engines, JSF F119, JSF F120, and F-22 F119. Planning for the F110-129, F100-229 and other engines in the operational inventory is in process. Detail is only given on the IHPTET demonstrators because of the competitive and proprietary issues associated with the product engines.

ACTION TEAM CHAIRS



Chair

Mr. Mark Dale
U.S. Air Force,
AFRL/PRTP, Bldg. 18 Room D201
1950 Fifth Street
Wright-Patterson AFB, OH 45433-7251
Phone: (937) 255-2767
Fax: (937) 656-4179
Email: mark.dale@wpafb.af.mil



Co-Chair

Mr. Dan Poggoshev
Naval Air Systems Command
AIR 4.4T Bldg. 106
22195 Elmer Road
Patuxent River, MD 20670-1534
Phone: (301) 757-0453
Fax: (301) 757-0534
Email: popgoshevd@navair.navy.mil

INTRODUCTION

The following pages contain tables and schedules, along with descriptions of objectives, HCF technologies validated, and results of current and planned HCF engine demonstrations. The tables identify the HCF technologies and engine demonstrator targets that have been planned to date with the General Electric / Allison Advanced Development Company team and with Pratt & Whitney. In general, the engine demonstrations are planned to provide the required data to validate the HCF technology performance and to update the design codes. The action teams develop technologies, then identify them as ready for engine demonstration. These technologies are then planned for incorporation into a core or engine test, which the tables identify. Once successfully demonstrated in a core or engine, a given technology is ready for transition into a fielded engine (F100, F110, etc.) or a development engine program (F119, JSF F119, JSF F120, etc.). Core or engine demonstration of HCF technologies will continue into 2005, but in some cases specific technologies and demonstration opportunities have not been identified.

General Electric / Allison Advanced Development Company Demonstration Targets

Action Team / Program Title	Engine Demonstrator					
	XTC76/2	XTE76/1	XTC76/3	XTE77SE	XTC77/1	XTE77/SE2
Passive Damping						
Ring Damper Design			X	X		
Mag-Spinel			X		X	
Fan Damper Design						X**
Material Damage Tolerance						
FOD Characterization Non Laser Shock Peen				X*		
Component Analysis						
Probabilistic Data & Correlation				X*	X**	X**
Instrumentation / Health Monitoring						
LIFTP	X*					
COPE Instrumentation		X				
RVM +TOA				X**		X**
Nonintrusive Stress Measurement System				X**	X**	
Environmental Mapping Validation			X			X**
Component Surface Treatment						
Laser Shock Peening Validation				X*		X
Forced Response Prediction System						
VBIA Analysis	X		X		X	
HPT/LPT interactions		X				
CFD Analysis & LEFF				X		X**
Aeromechanical Characterization						
Pressure Mapping						
X* - Research Agenda Milestones achieved						
X** - Currently Unfunded						

7.1 General Electric / Allison Advanced Development Company

The main focus of the GE/AADC demonstrator programs is to provide the test beds for the evaluation of Integrated High Performance Turbine Engine Technology (IHPTET) Program technologies and new HCF technologies. These critical core and engine demonstrations assess the performance and mechanical characteristics of HCF technologies in a realistic engine environment and provide the data necessary to validate and update advanced HCF prediction tools.

7.1.1 XTC76/2 *FY 99 (1st Qtr)*

Objectives: Demonstrate technologies to achieve the Integrated High Performance Turbine Engine Technology (IHPTET) Program Phase II T41 objective, variable cycle engine concept, and advanced core technologies required to meet the IHPTET Phase II thrust-weight goals.

HCF Technologies Demonstrated: The need for compressor flutter design and test methods was demonstrated.

Final Results: This test demonstrated the importance of advanced unsteady design methods for use on modern low-aspect-ratio compressor airfoils, which have stability properties outside traditional experience.

Participating Organizations: Air Force Research Laboratory (AFRL), GE Aircraft Engines / Allison Advanced Development Company (AADC)

Points of Contact:

Government

Mr. Michael Barga
U.S. Air Force, AFRL/PRTP
1950 Fifth St., Bldg. 18D
Wright-Patterson AFB, OH 45433-7251
Phone: (937) 255-2767
Fax: (937) 656-4179
Email: michael.barga@afrl.af.mil

Contractor

Dr. Dennis Corbly / Mr. Durell Wildman
GE Aircraft Engines/AADC
Allison Advanced Development Co.
2056 South Tibbs Ave.
Indianapolis, IN 46207
Phone: (317) 230-5670
Fax: (317) 230-6100
Email: durell.wildman@aadc.com

7.1.2 XTC76/3

FY 01 (3rd Qtr)

Objectives: Demonstrate the core technologies required to meet the IHPTET Phase II thrust-to-weight goal and the structural durability of the advanced technologies. HCF technologies to be validated in this core include unsteady aerodynamics, damping, and the Non-Contact Stress Measurement System (NSMS).

Details/Progress: Flutter analysis will be done with a fully-coupled 3D nonlinear unsteady code. REDUCE has been used to investigate mistuning in Stage 2 compressor blades. Hard damping coatings and ring dampers have been designed for this compressor. The effectiveness of these damping treatments will be evaluated on the bench and in engine testing. NSMS instrumentation will be used to gather blade response data for correlation with predictions.

Participating Organizations: Air Force Research Laboratory (AFRL), Naval Air Warfare Center (NAWC), GE Aircraft Engines / Allison Advanced Development Company (AADC)

Points of Contact:

Government

Mr. Michael Barga
U.S. Air Force, AFRL/P RTP
1950 Fifth St., Bldg. 18D
Wright-Patterson AFB, OH 45433-7251
Phone: (937) 255-2767
Fax: (937) 656-4179
Email: michael.barga@afrl.af.mil

Contractor

Dr. Dennis Corbly / Mr. Durell Wildman
GE Aircraft Engines/AADC
Allison Advanced Development Co.
2056 South Tibbs Ave.
Indianapolis, IN 46207
Phone: (317) 230-5670
Fax: (317) 230-6100
Email: durell.wildman@aadc.com

7.1.3 XTE77/SE *FY 03 (2nd Qtr)*

Objectives: Demonstrate the integration of advanced fan and turbine technologies into an engine system; provide an early risk reduction evaluation of Phase III technologies.

HCF Technologies to Be Demonstrated: Application of Laser Shock Peening (LSP) to forward-swept fans; unsteady aero predictions with a variety of codes; correlation with the Non-Contact Stress Measurement System (NSMS) and other monitoring sensors; the impact of low-excitation features in front frames; application of probabilistic assessment methods.

Details/Progress: This demo was placed on contract in late 1999.

Participating Organizations: Air Force Research Laboratory (AFRL), GE Aircraft Engines / Allison Advanced Development Company (AADC)

Points of Contact:

Government

Mr. Dan Popgoshev
Naval Air Systems Command
AIR 4.4T Bldg. 106
22195 Elmer Road
Patuxent River, MD 20670-1534
Phone: (301) 757-0453
Fax: (301) 757-0534
Email: popgoshevd@navair.navy.mil

Contractor

Dr. Dennis Corbly
GE Aircraft Engines
1 Neumann Way
A413
Cincinnati, OH 45215-1988
Phone: (513) 243-5832
Fax: (513) 243-8091
Email: dennis.corbly@ae.ge.com

7.1.4 XTE76/1

FY 02 (2nd Qtr)

Objectives: Demonstrate the integration of advanced fan and low-pressure turbine technologies into an engine system. This engine demonstration will achieve the Integrated High Performance Turbine Engine Technology (IHPTET) Program Phase II thrust-to-weight goal.

HCF Technologies to Be Demonstrated: Application of advanced unsteady design methods on vaneless, counterrotating high-pressure (HP) and low-pressure (LP) turbine systems will be demonstrated. Advanced instrumentation will be used to gather unsteady data on the HP/LP turbine system.

Details/Progress: Hardware is currently being fabricated in preparation for the engine demonstration.

Participating Organizations: Air Force Research Laboratory (AFRL), GE Aircraft Engines / Allison Advanced Development Company (AADC)

Point of Contact:

Government

Mr. Mark Dale
U.S. Air Force, AFRL/PRTP
1950 Fifth St., Bldg. 18D
Wright-Patterson AFB, OH 45433-7251
Phone: (937) 255-2767
Fax: (937) 656-4531
Email: mark.dale@wpafb.af.mil

Contractor

Dr. Dennis Corbly / Mr. Durell Wildman
GE Aircraft Engines/AADC
1 Neumann Way
A413
Cincinnati, OH 45215-1988
Phone: (513) 243-5832
Fax: (513) 243-8091
Email: dennis.corbly@ae.ge.com

7.1.5 XTC77

FY 04 (1st Qtr)

Objectives: Demonstrate the technologies required to achieve the Integrated High Performance Turbine Engine Technology (IHPTET) Program Phase III thrust-to-weight goal.

HCF Technologies to Be Demonstrated: Advanced technologies in the areas of damping, instrumentation, and design methods, including probabilistic and unsteady aerodynamics.

Details/Progress: This effort is in the preliminary design phase.

Participating Organizations: Air Force Research Laboratory (AFRL), GE Aircraft Engines / Allison Advanced Development Company (AADC)

Points of Contact:

Government

Mr. Michael J. Kinsella
U.S. Air Force, AFRL/P RTP
1950 Fifth St., Bldg. 18D
Wright-Patterson AFB, OH 45433-7251
Phone: (937) 255-2767
Fax: (937) 656-4179
Email: michael.kinsella@wpafb.af.mil

Contractor

Dr. Dennis Corbly / Mr. Durell Wildman
GE Aircraft Engines/AADC
1 Neumann Way
A413
Cincinnati, OH 45215-1988
Phone: (513) 243-5832
Fax: (513) 243-8091
Email: dennis.corbly@ae.ge.com

Pratt & Whitney Demonstration Targets

Action Team / Program Title	Engine Demonstrator							
	XTE66/A1	XTC66SE	XTC66/1	XTE66/1	XTC67	XTE65/3	XTE67/1	XTE67/2
Passive Damping								
High Effectiveness Turbine Damping				X			X	X
IBR Dampers					X			X
Material Damage Tolerance								
Titanium Demonstration						X		
Single Crystal Demonstration							X	X
Gamma-Ti Demonstration		X			X		X	
Component Analysis								
Probabilistic HCF Assessment							X	X
FEM Modeling Enhancements	X	X	X	X	X	X	X	X
Instrumentation / Health Monitoring								
Generation IV NSMS					X		X	
Non-Optical NSMS	X						X	
Advanced Pyrometry					X			
Component Surface Treatment								
LSP Demonstration						X		
Forced Response Prediction System								
Robust Airfoil Design / FLARES	X		X	X	X		X	
Aeromechanical Characterization								
HCF Design Tool Eval/Tech Transition								X
X - Research Agenda Milestones achieved								

7.2 Pratt & Whitney

The main benefit of the P&W demonstrator programs to the HCF Initiative is to provide the test beds for the initial evaluation of new HCF technologies. These critical core and engine demonstrations, in addition to demonstrating improved thrust-to-weight and providing a validation for technology transition candidates, assess the performance and mechanical characteristics of HCF technologies in a realistic engine environment and provide the data necessary to validate and update advanced HCF prediction tools.

7.2.1 **XTE66/A1** *FY 95 (4th Qtr)*

Objectives: Validate the F119 Hollow Fan Blade integrally bladed rotor (IBR) in an engine environment.

HCF Technologies Demonstrated: Unsteady aerodynamic and forced response (FLARES) codes; first-generation eddy current sensor

Final Results: HCF tools correctly identified the root cause and fix for unacceptable rotor response. Demonstration of the eddy current sensor to measure blade tip response was successfully completed.

Participating Organizations: Air Force Research Laboratory (AFRL), Pratt & Whitney Independent Research & Development (P&W IR&D)

Points of Contact:

Government

Capt Anthony Cerminaro
U.S. Air Force, AFRL/P RTP
1950 Fifth St., Bldg. 18D
Wright-Patterson AFB, OH 45433-7251
Phone: (937) 255-2767
Fax: (937) 255-2278
Email: anthony.cerminaro@wpafb.af.mil

Contractor

Mr. Bill Doehnert
Pratt & Whitney M/S 715-01
P. O. Box 109600
West Palm Beach, FL 33410-9600
Phone: (561) 796-6639
Fax: (561) 796-4901
Email: dohnrtw@pwfl.com

7.2.2 XTC66/SC FY 97 (3rd Qtr)

Objectives: Demonstrate and evaluate F119 technology transition, Joint Strike Fighter (JSF) technology maturation risk reduction, and Integrated High Performance Turbine Engine Technology (IHPTET) Program technologies.

HCF Technologies Demonstrated: Robustness of gamma-TiAl high-pressure compressor (HPC) blades; supercooled high-pressure turbine (HPT) blades

Final Results: Testing demonstrated the HCF robustness of gamma-TiAl blades and supercooling technologies.

Participating Organizations: Air Force Research Laboratory (AFRL), Naval Air Warfare Center (NAWC), Pratt & Whitney

Points of Contact:

Government

Mr. Marty Huffman
U.S. Air Force, AFRL/PRTP
1950 Fifth St., Bldg. 18D
Wright-Patterson AFB, OH 45433-7251
Phone: (937) 255-2767
Fax: (937) 255-2278
Email: martin.huffman@wpafb.af.mil

Contractor

Mr. Bob Morris
Pratt & Whitney M/S 163-24
400 Main Street
East Hartford, CT 06108
Phone (860) 565-8653
Fax: (860) 565-5494
Email:Morrisrj@pweh.com

7.2.3 XTC66/1B *FY 98 (1st Qtr)*

Objectives: Demonstrate the temperature, speed, and structural capability of the core to run Integrated High Performance Turbine Engine Technology (IHPTET) Program Phase II conditions; evaluate the aerodynamic and thermodynamic performance of the high-pressure compressor (HPC), Diffuser/Combustor, and high-pressure turbine (HPT).

HCF Technologies Demonstrated: Unsteady aerodynamic (NASTAR V3.0) and forced response (FLARES V1.0) codes

Final Results: Testing provided benchmark data for analytical tool calibration and validation. Data have been used to establish code performance against Action Team metrics.

Participating Organizations: Air Force Research Laboratory (AFRL), Pratt & Whitney

Points of Contact:

Government

Mr. David Jay
U.S. Air Force, AFRL/PRTD
1950 Fifth St., Bldg. 18D
Wright-Patterson AFB, OH 45433-7251
Phone: (937) 255-2767
Fax: (937) 255-2278
Email: david.jay@wpafb.af.mil

Contractor

Mr. Bill Campbell
Pratt & Whitney
M/S 715-01
P. O. Box 109600
West Palm Beach, FL 33410-9600
Phone: (561)796-5179
Email:campbell@pwfl.com

7.2.4 XTE66/1 *FY 99 (2nd Qtr)*

Objectives: (1) Demonstrate the Integrated High Performance Turbine Engine Technology (IHPTET) Program Phase II thrust-to-weight goal. (2) Provide initial engine demonstration of a vaneless counter-rotating turbine and microwave augmentor.

HCF Technologies Demonstrated: Internal low-pressure turbine (LPT) dampers for control of high-frequency excitation

Final Results: A counter-rotating vaneless turbine was successfully demonstrated. Low turbine (LPT2) blade stresses were low in higher-order modes. The configuration was evaluated with FLARES for comparison to Action Team metrics. Durability testing of these advanced dampers will be conducted in an HCF spin test at the Naval Postgraduate School in the second quarter of fiscal year 2001.

Participating Organizations: Air Force Research Laboratory (AFRL), Pratt & Whitney

Points of Contact:

Government

Capt Tony Cerminaro
U.S. Air Force, AFRL/PRTP
1950 Fifth St., Bldg. 18D
Wright-Patterson AFB, OH 45433-7251
Phone: (937) 255-2767
Fax: (937) 255-2278
Email: anthony.cerminaro@wpafb.af.mil

Contractor

Mr. Bob Morris
Pratt & Whitney M/S 163-24
400 Main Street
East Hartford, CT 06108
Phone (860) 565-8653
Fax: (860) 565-5494
Email: Morrisrj@pweh.com

7.2.5 XTC67/1 *FY 01 (3rd Qtr)*

Objectives: Demonstrate the temperature, speed, and structural capability of the core to run Integrated High Performance Turbine Engine Technology (IHPTET) Program Phase II and some early Phase III conditions and to evaluate the high-pressure compressor (HPC), Diffuser/Combustor, and high-pressure turbine (HPT) aerodynamic and thermodynamic performance.

HCF Technologies to be Demonstrated: Generation 4 Non-Contact Stress Measurement System (NSMS); Advanced Pyrometry; Finite Element Modeling (FEM) enhancements; the FLARES (v2.0) Code; asymmetric high-pressure compressor (HPC) stators; Comprehensive Engine Condition Management (CECM); improved platform dampers in the high-pressure turbine (HPT)

Progress to Date: Hardware fabrication is in final stages of completion, and core instrumentation and assembly is in progress with testing scheduled in the second quarter of fiscal year 2001.

Participating Organizations: Air Force Research Laboratory (AFRL), Pratt & Whitney

Points of Contact:

Government

Mr. David Jay
U.S. Air Force, AFRL/PRTP
1950 Fifth St., Bldg. 18D
Wright-Patterson AFB, OH 45433-7251
Phone: (937) 255-2767
Fax: (937) 255-2278
Email: david.jay@wpafb.af.mil

Contractor

Mr. Howard Gregory
Pratt & Whitney M/S 165-21
400 Main Street
East Hartford, CT 06180
Phone: (860) 565-4682
Fax: (860) 565-1323
Email: gregoryh@pweh.com

7.2.6 XTE66/SE

FY 98 (1st Qtr)

Objectives: Demonstrate the structural durability of Integrated High Performance Turbine Engine Technology (IHPTET) Program technologies in an F119 engine; transition some of those technologies to the F119 for the F-22 or Joint Strike Fighter (JSF) aircraft. The demonstration was an accelerated mission test (AMT) using an F-22 Initial Flight Release (IFR) mission.

HCF Technologies Demonstrated: Robustness of gamma-Ti compressor blades, Supervanes and Superblades

Final Results: The engine completed 1505 accelerated mission testing (AMT) “total accumulated cycles” (TACs), and most of the technology component hardware met durability predictions.

Participating Organizations: Air Force Research Laboratory (AFRL), Naval Air Warfare Center (NAWC), Pratt & Whitney

Points of Contact:

Government

Mr. Marty Huffman
U.S. Air Force, AFRL/P RTP
1950 Fifth St., Bldg. 18D
Wright-Patterson AFB, OH 45433-7251
Phone: (937) 255-2767
Fax: (937) 255-2278
Email: martin.huffman@wpafb.af.mil

Contractor

Mr. Willard Pospisil
Pratt & Whitney M/S 165-21
400 Main Street
East Hartford, CT 06180
Phone: (860) 565-0028
Fax: (860) 565-1323
Email: pospisl@pweh.com

7.2.7 XTE67/1

FY 01 (3rd Qtr)

Objectives: Demonstrate the temperature, speed, and structural capability of the engine to run early Integrated High Performance Turbine Engine Technology (IHPTET) Program Phase III conditions; evaluate the low spool and integrated aerodynamic and thermodynamic performance.

HCF Technologies to be Demonstrated: Integrally bladed rotors (IBRs) designed for low resonant stress and flutter response, IBR damping, lightweight turbine dampers, and high-temperature eddy current sensors will be validated. Analytical tools to be applied during the XTE67/1 design include unsteady aerodynamics, FLARES (v2.0), MDA, BDAMPER (v7.0), and CDAMP (v2.0).

Progress to Date: The final design review for XTE67/1 was held in November 1999. Hardware fabrication is in progress, with testing scheduled in the third quarter of fiscal year 2001.

Participating Organizations: Air Force Research Laboratory (AFRL), Naval Air Warfare Center (NAWC), Pratt & Whitney

Points of Contact:

Government

Capt Anthony Cerminaro
U.S. Air Force, AFRL/PRTD
1950 Fifth St., Bldg. 18D
Wright-Patterson AFB, OH 45433-7251
Phone: (937) 255-2767
Fax: (937) 255-2278
Email: anthony.cerminaro@wpafb.af.mil

Contractor

Mr. Willard Pospisil
Pratt & Whitney M/S 165-21
400 Main Street
East Hartford, CT 06180
Phone: (860) 565-0028
Fax: (860) 565-1323
Email: pospisl@pweh.com

7.2.8 XTE65/3

FY 00 (2nd Qtr)

Objectives / HCF Technologies to be Demonstrated: (1) Demonstrate the utility and accuracy of new fan blade damage tolerance HCF tools during engine testing of damaged blades. (2) Evaluate benefits of Laser Shock Peening of titanium integrally bladed rotors (IBRs) to mitigate damage-induced fatigue debits.

Progress to Date: An “event” on August 2, 2000, during initial check-out of the engine resulted in significant damage to the engine. Root cause analysis and recovery planning is currently in progress. Several options to complete the HCF testing have been identified, and selection of a specific testing option is in progress.

Participating Organizations: Air Force Research Laboratory (AFRL), Pratt & Whitney Independent Research & Development (P&W IR&D)

Points of Contact:

Government

Capt Anthony Cerminaro
U.S. Air Force, AFRL/P RTP
1950 Fifth St., Bldg. 18D
Wright-Patterson AFB, OH 45433-7251
Phone: (937) 255-2767
Fax: (937) 255-2278
Email: anthony.cerminaro@wpafb.af.mil

Contractor

Mr. Willard Pospisil
Pratt & Whitney M/S 165-21
400 Main Street
East Hartford, CT 06180
Phone: (860) 565-0028
Fax: (860) 565-1323
Email: pospisl@pweh.com

7.2.9 XTE67/SE1

FY 02 (3rd Qtr)

Objectives / HCF Technologies to be Demonstrated: (1) Demonstrate new HCF instrumentation technologies in an engine environment. (2) Gather aeromechanical and aerothermal data to validate and update analytical tools.

Progress to Date: The engine to support the first build of the structural engine (SE1) has been purchased. Delivery of the engine is scheduled for the fourth quarter of fiscal year 2001. A review of current system issues has been used to identify candidate instrumentation types and locations.

Participating Organizations: Air Force Research Laboratory (AFRL), Pratt & Whitney Independent Research & Development (P&W IR&D)

Points of Contact:

Government

Capt Anthony Cerminaro
U.S. Air Force, AFRL/PRTP
1950 Fifth St., Bldg. 18D
Wright-Patterson AFB, OH 45433-7251
Phone: (937) 255-2767
Fax: (937) 255-2278
Email: anthony.cerminaro@wpafb.af.mil

Contractor

Mr. Howard Gregory
Pratt & Whitney M/S 165-21
400 Main Street
East Hartford, CT 06180
Phone: (860) 565-4682
Fax: (860) 565-1323
Email: gregoryh@pweh.com

7.2.10 XTE67/SE2

FY 03 (4th Qtr)

Objectives / HCF Technologies to be Demonstrated: (1) Provide a vehicle for demonstration and transition of new technologies to F-22 High Rate Production and to JSF programs from the national High Cycle Fatigue and Turbine Engine Durability initiatives. (2) Validate the durability of new component technologies through accelerated testing and implementation of new HCF test protocols.

Progress to Date: The base program test vehicle has been selected. A candidate list of technologies has been identified.

Participating Organizations: Air Force Research Laboratory (AFRL), Pratt & Whitney Independent Research & Development (P&W IR&D)

Points of Contact:

Government

Capt Anthony Cerminaro
U.S. Air Force, AFRL/PRTP
1950 Fifth St., Bldg. 18D
Wright-Patterson AFB, OH 45433-7251
Phone: (937) 255-2767
Fax: (937) 255-2278
Email: anthony.cerminaro@wpafb.af.mil

Contractor

Mr. Howard Gregory
Pratt & Whitney M/S 165-21
400 Main Street
East Hartford, CT 06180
Phone: (860) 565-4682
Fax: (860) 565-1323
Email: gregoryh@pweh.com

7.3 Conclusion

The XTC67 and the XTE65/3 were both planned to test this year. The XTE65/3 was a well-used engine that finally gave out prior to the beginning of the planned testing. Root cause analysis and recovery planning is currently in progress. Several options to complete the HCF testing have been identified, and selection of a specific testing option is yet to be determined. The testing of the XTC67 has slipped to May 2001 due to hardware design and fabrication complications. The addition of an XTE77 Fan rig test will now provide additional data to help determine the HCF characteristics and reduce the risk of the engine test.

The JSF F120 First Core Engine to Test was performed this year. Data from that test is still being analyzed. The next scheduled test is the XTC76/3 core test prior to the XTE76 engine test scheduled to begin by the end of calendar year 2001.

8.0 AEROMECHANICAL CHARACTERIZATION



BACKGROUND

The Aeromechanical Characterization Action Team (Aeromechanical AT) is responsible for fostering collaboration between individual HCF programs and test opportunities with the goal of providing the required design and test verification focus for the entire HCF S&T program. The Aeromechanical AT provides technical coordination and communication between active participants involved in HCF testing technologies and the Test and Evaluation Plan under development at Arnold Engineering Development Center (AEDC). Annual technical workshops have been organized, and summaries of these workshops are disseminated to appropriate individuals and organizations. The Chair, Co-Chair, and selected Aeromechanical AT members meet annually to review technical activities, develop specific goals for test and evaluation programs, and review technical accomplishments. The Chair (or Co-Chair) reports to the Technical Plan Team (TPT) and National Coordinating Committee (NCC) on an annual basis. The secretary of the TPT is informed of AT activities as needed. This AT includes members from government agencies, industry, and universities who are actively involved in technologies applicable to turbine engine HCF. The team is to be multidisciplinary, with representatives from multiple organizations representing several component technologies as appropriate. The actual membership of the AT will change as individuals assume different roles in related programs.

ACTION TEAM CHAIRS



Chair

Dr. Douglas C. Rabe
U.S. Air Force, AFRL/PRTX
1950 Fifth Street, Bldg. 18D
Wright-Patterson AFB, OH 45433-7251
Phone: (937) 255-6802 x231
Fax: (937) 255-0898
Email: douglas.rabe@terc.wpafb.af.mil

Co-Chair

Mr. Joseph Babilon
U.S. Air Force, AFRL/PRTC
AEDC/DOT, M/S 9011
1099 Avenue E
Arnold AFB, TN 37389-9011
Phone: (937) 255-3720
Fax: (937) 454-3559
Email: babilon@hap.arnold.af.mil

INTRODUCTION

The following pages summarize the schedules, descriptions, and progress of the current and planned projects managed by this action team.

8.1 Compressor Mistuning Characterization

FY 97-99

Background

The objectives of this task were to characterize mistuned response at speed in an integrally bladed disk (or “blisk”) and to compare experimental results to mistuning code predictions. The findings can be used to evaluate and improve mistuning prediction codes for more accurate prediction of stresses and stress variations. Research is currently being applied to fans, but may also be extended to compressors and turbines. Structural variations in turbomachine blades cause variations in the natural frequencies of the blades, known as mistuning. Mistuning leads to mode localization, which can cause dangerously high resonant stresses in a single blade or group of blades. Various factors, including manufacturing tolerances, wear, and unsteady aerodynamics, can affect the mistuned response. Measurement of the mistuned response and characterization of the factors influencing the response are necessary to develop accurate stress prediction models that account for the effects of mistuning.

Final Results

The rotor was tested, and the mistuned response of the blisk was characterized for the modes of interest. Mistuned response was affected by different factors for different modes. Aerodynamic coupling dominated the mistuned response at the first blade mode. Comparison to the model yielded significant qualitative insight but indicated a need for improved modeling of aerodynamic effects. The second and third modes occurred at nearly the same frequency, resulting in mode interaction, as shown in Figure 103. Because of this, these modes were difficult to characterize, both experimentally and analytically. Results indicate a need for additional modeling of mode interaction, unsteady aerodynamics, and improved physics-based modeling of the fundamental structural mistuning problem. Experimental characterization efforts for this project are concluded until further developments in modeling are achieved.

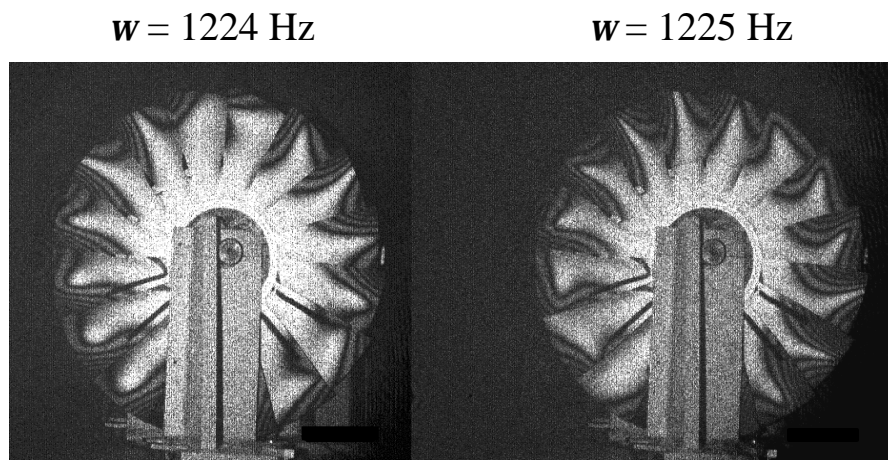

FIGURE 103. 2B/1T Mode Interaction.

Participating Organizations: Air Force Research Laboratory

Point Of Contact

Government

Dr. James Kenyon
U.S. Air Force, AFRL/PRTE
1950 Fifth Street, Building 18D
Wright-Patterson AFB, OH 45433-7251
Phone: (937) 255-6802
Fax: (937) 255-0898
E-mail: james.kenyon@wpafb.af.mil

8.2 Fretting Characterization

FY 98-01

Background

The objective of this task is to develop an understanding of the mechanical drivers in fretting fatigue and develop techniques to minimize their impact on material behavior. In particular the metal-to-metal dovetail attachment of blade and disk attachments will be studied. Fretting fatigue is approximately 6 percent of all HCF failures. The elimination of this problem correlates to six million dollars (\$6,000,000) per annum saved in maintenance costs.

The primary mechanical life drivers will be established through a systematic variation of various contacting bodies, the first of which will be “dog bone” specimens placed into contact by cylindrical pads. Different contact loads will be applied to determine the effect of the applied loads on fretting fatigue. Fatigue parameters will be evaluated as to their ability to predict the number of cycles to crack initiation, crack location, and crack orientation along the contact surface. The evaluation process will provide the basic mechanisms for fretting fatigue crack initiation for metal to metal contact. The second phase of the program will concentrate on real blade-disk geometry. Simulated contact surfaces will be loaded in a manner similar to those experienced in a turbine engine environment. The fatigue parameters developed for fundamental surfaces will be evaluated and modified as necessary to predict fretting fatigue on the real blade-disk geometry. Subsequent programs will then explore techniques to minimize the detrimental effects of fretting fatigue in turbine engines.

As of December 1999, 96 “dog bone” specimens had been fabricated and tested to failure. Fatigue parameter evaluation had been completed on the simplified geometry. A single fir tree specimen, which is symbolic of the real part, was being modeled via finite element analysis. A fretting fatigue parameter had been developed based on the interaction between a plain fatigue specimen and a simplified pad geometry. It had been determined that fretting fatigue crack initiation occurred on the plane of maximum shear stress amplitude and that it was dependent on the amount of slip at the crack location. A simulated blade dovetail and disk slot (single fir tree component) had been modeled and CAD drawings had been developed for machining.

The simulated blade-dovetail and disk slot were to be tested in order to assess the accuracy of the fretting fatigue mechanisms determined through the simplified geometry approach. The robustness of the predictive model were to be evaluated by considering the crack initiation behavior on the single fir tree component. The final phase of fretting fatigue research would involve employing methods such as

coatings and compressive residual stresses in order to alleviate the fretting damage induced at the blade disk interface. The estimated completion date was September 2001.

Recent Progress

No report was submitted in 2000. The information above was reported December 1999.

Participating Organizations: Air Force Research Laboratory, Air Force Institute of Technology, Pratt & Whitney

Point Of Contact

Government

Mr. Christopher Lykins
U.S. Air Force, AFRL/PRTC
1950 Fifth St., Bldg. 18D
Wright-Patterson AFB, OH 45433-7251
Phone: (937) 656-5530
Fax: (937) 255-2660
Email: christopher.lykins@wpafb.af.mil

8.3 Spin-Pit Excitation Methods

FY 99-01

Background

The objective of this task is to develop a reliable and controlled method for exciting and measuring blade and rotor resonance modes of interest using a spin-pit test. Steady-state blade excitation in a spin pit will enable potential HCF problems and fixes to be addressed early in the development cycle of a rotor. This capability will provide a low-cost alternative to the expensive verification tools (rig and engine testing) currently in use.

Recent Progress

The four methods downselected for analysis and preliminary development were flow fences, low density air jets, liquid jets, and condensing jets. These four methods were tested using an instrumented four-bladed rotor and results presented at the Preliminary Design Review (PDR) held at the Test Devices facility in September 2000. The PDR was attended by the Air Force, the Navy, Pratt & Whitney, General Electric, and Rolls-Royce Allison.

As a result of the PDR, additional testing was performed using liquid jets, which showed excellent potential during early testing, to determine the effect of the liquid impacts on the rotor surfaces. Preliminary tests showed that high erosion rates were possible and that erosion mitigation techniques needed to be developed. Erosion mitigation testing will be performed early in 2001, after which the method for full-scale development will be downselected.

Participating Organizations: Air Force Research Laboratory (AFRL), Naval Air Warfare Center (NAWCAD), Test Devices Incorporated

Points of Contact:

Government

Mr. Frank Lieghley
U.S. Air Force, AFRL/PRTC
1950 Fifth St., Bldg. 18D
Wright-Patterson AFB, OH 45433-7251
Phone: (937) 255-1867
Fax: (937) 255-2660
Email: Frank.Lieghley@wpafb.af.mil

Contractor

Mr. Rick Connell
Test Devices Incorporated
6 Loring St.
Hudson, MA 01749
Phone: (978)562-6017 ext. 222
Fax: (978)562-7939
Email: rconnell@testdevices.com

8.4 Compressor Blade Fracture and Fatigue Evaluation

FY 98-00

Background

The objective of this effort was to determine the enhancement capabilities of Laser Shock Peening (LSP) on Foreign Object Damage (FOD) tolerance and HCF resistance when applied to real gas turbine engine compressor blades. A series of F100-PW-229 fourth-stage compressor blades were to be evaluated. LSP-treated and untreated blades were to be driven to failure at a resonance condition on a shaker table. FOD damage was to be simulated on some of the LSP-treated and untreated blades by machining a notch at the leading edge of the blade. The fatigue lives of the LSP-treated and untreated blades with and without the simulated FOD were to be compared to determine the damage tolerance enhancement of LSP.

In 1999, airfoils were delivered to the Turbine Engine Fatigue Facility (TEFF) at Wright-Patterson Air Force Base, Ohio, and testing was initiated. Twelve airfoils fatigued before experimental problems developed. The shaker system was expected to be back on-line and testing was expected to resume in early 2000. Testing on the F100-PW-229 fourth-stage airfoils was expected to be completed by September 2000.

Recent Developments

The most recent report (above) was submitted in December 1999.

Participating Organizations: Air Force Research Laboratory (AFRL)

Point of Contact:

Government

Dr. Charles Cross
U.S. Air Force, AFRL/PRTC
1950 Fifth St., Bldg. 18D
Wright-Patterson AFB, OH 45433-7251
Phone: (937) 656-5530
Fax: (937) 255-2660
Email: charles.cross@wpafb.af.mil

8.5 Rotational Validation of Mistuning Model

FY 99-00

Background

The objective of this task was to validate the REDUCE reduced order mistuning model developed at the University of Michigan under the GUIde Forced Response Consortium. Initial evaluation using engine hardware (see Section 8.1) has been performed, and the reduced order modeling code has shown promise in predicting mistuning response in full engine hardware. However, full validation of the model is needed and will allow for a more complete understanding of structural mistuning and application of this code in the HCF test protocol.

In this study, a simulated bladed disk assembly (Fig. 104) was to be intentionally mistuned based on the reduced order model predictions, and then experimentally evaluated. Validation data was to be obtained from bladed disks under stationary and rotational conditions. Stationary data was to be obtained through laser vibrometry at the University of Michigan. Additional stationary and rotational test data was to be acquired using strain gages, holography, and SPATE in the vacuum chamber of the Turbine Engine Fatigue Facility of the Air Force Research Laboratory. The experimental results from the mistuned disks were to be compared to the reduced ordered modeling predictions.

At the end of 1999, experimental equipment was in place at both the Air Force Research Laboratory and the University of Michigan. Design of final test articles was complete and the disks were being machined. Testing of the components was scheduled to begin in early 2000.

Recent Progress

No report was submitted in 2000. The information above was reported December 1999.



FIGURE 104. Mistuning Validation Simulated Bladed Disk

Participating Organizations: Air Force Research Laboratory (AFRL)

Points of Contact:

Government

Dr. Charles Cross
U.S. Air Force, AFRL/PRTC
1950 Fifth St., Bldg. 18D
Wright-Patterson AFB, OH 45433-7251
Phone: (937) 656-5530
Fax: (937) 255-2660
Email: charles.cross@wpafb.af.mil

Contractor

Dr. Christophe Pierre
University of Michigan
2250 G. G. Brown Bldg.
2350 Hayward Street
Department of Mechanical Engineering and Applied Mechanics
The University of Michigan
Ann Arbor, MI 48109-2125
Phone: (734) 936-0401
Fax: (734) 647-7303
Email: pierre@umich.edu

8.6 Development of Multi-Axial Fatigue Testing Capability *FY 98-00*

Background

The objective of this task was to develop the capability to test turbine engine components in a bench-test environment that simulates vibrational loading effects experienced during engine operation. Research goals were to develop a test system that simulates operational blade loading and to develop a data acquisition system that accurately monitors critical test parameters. This test capability was to provide a low-cost method to evaluate turbine engine blades for HCF.

A test fixture (Fig. 105) was designed and constructed to test gas turbine blades under biaxial loading conditions. A load cell on the primary axis was employed to simulate the centrifugal loading experienced by the blade. A ram on a second axis allowed for vibrational loads simulating bending to be induced in the airfoil. Combined, the loading allows for fatigue testing under simulated operational environments. In Phase II, the concept was extended for multi-axial fatigue. Two rams were positioned on the second axis, and depending on their relative position, either bending or torsion could be induced in the airfoil.

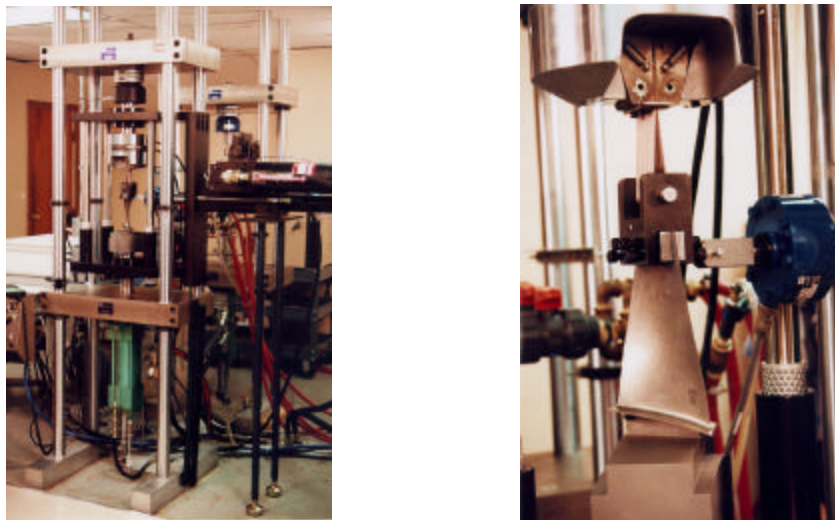

FIGURE 105. Proof of Concept Biaxial Fatigue Fixture

In 1999, the design of the multi-axial fatigue frame (Figure 106) and installation in the Turbine Engine Fatigue Facility (TEFF) were completed, and shakedown of the system and initial testing began. Testing of fan blades was scheduled to begin in early 2000.

Recent Progress

No report was submitted in 2000. The information above was reported December 1999.

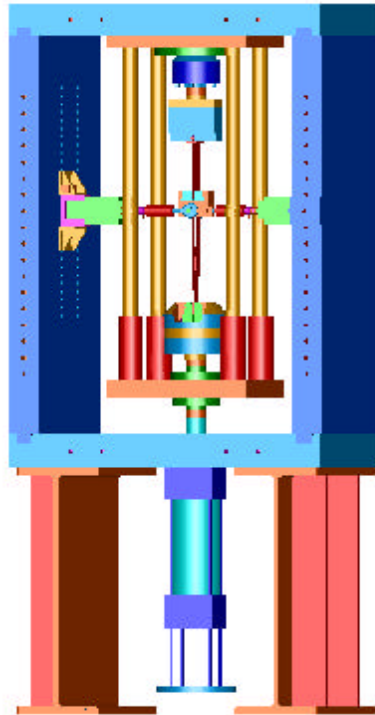

FIGURE 106. Multi-Axial Fatigue Model

Participating Organizations: Air Force Research Laboratory (AFRL)

Points of Contact:

Government

Mr. Gary Terborg
U.S. Air Force, AFRL/PRTC
1950 Fifth St., Bldg. 18D
Wright-Patterson AFB, OH 45433-7251
Phone: (937) 656-5530
Fax: (937) 255-2660
Email: Gary.Terborg@wpafb.af.mil

Contractor

Dr. Ming Xie
AdTech Systems Research
1342 N. Fairfield Rd.
Dayton, OH 45432
Phone: (937) 426-3329
Fax: (937) 426-8087
Email: mingxie@compuserve.com

8.7 Inlet Distortion Characterization

FY 99-00

Background

The objective of this project was to develop a technique to produce inlet flows that simulate conditions experienced in flight. This will improve the fan system development process for aeromechanical evaluation of blade vibrations due to inlet flow distortions. As a result of this effort, aeromechanical risks to fan systems will be reduced by implementing a proper test and evaluation technique to simulate appropriate inlet flow field conditions, which are similar to those experienced in flight. The outcome of this program will be incorporated in the HCF test protocol. The technical challenge is to accurately predict the inlet flow distortion and the resulting unsteady forces experienced by a fan. In particular, key modeling requirements need to be determined for defining the excitation types on the fan's vibratory response. The approach is to use data analysis and computational analysis methods of flight, ground, and model tests of the F-16/F110, and the model test data of an Advanced Compact Inlet System (ACIS).

The correlation of vibratory stress versus excitation strength, defined by a Modal Excitation Index (MEI), is shown in Figure 107, and is based on the initial data analysis of roughly 50 conditions from the flight tests of the F-16/F110 flight. This stress-versus-MEI correlation is based on the use of the two rings of total pressure measurements obtained during the flight test. It does NOT include the effects of distortions in other flow variables, namely static pressure and flow angularity.

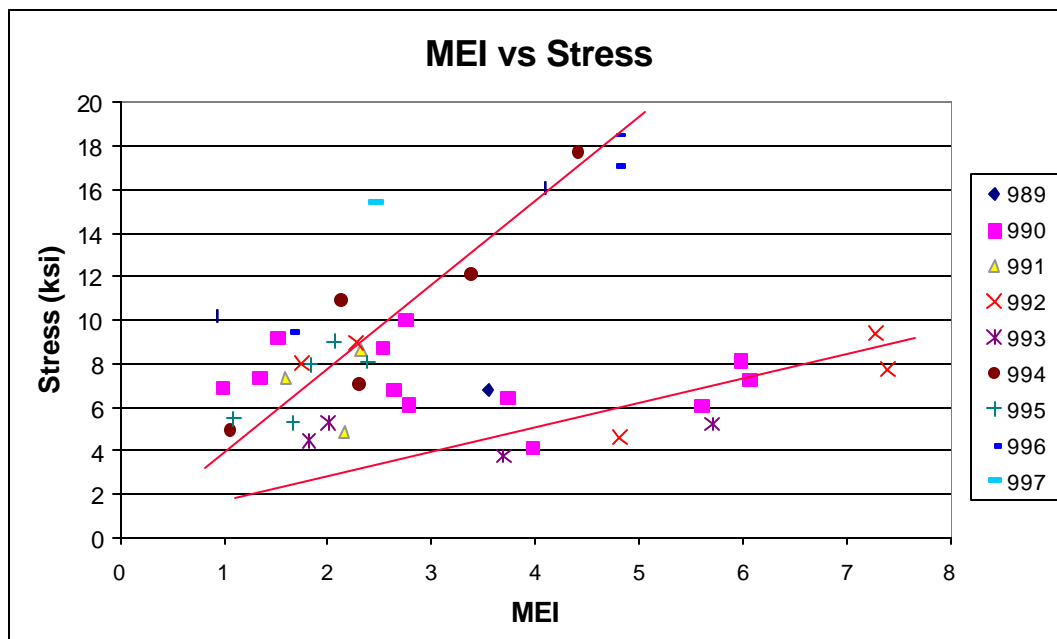

FIGURE 107. Initial Correlation between Vibratory Stresses and Modal Excitation Index (MEI)

This initial attempt shows the potential of using the MEI method to correlate with vibratory stress. However, two distinct, linear curves are shown in the correlation. Further analysis was performed to determine whether the differences are due to the inability to accurately resolve the distortions radially when only using two rings of information. To help demonstrate this, Figure 108 shows the comparison between predictions obtained from computational fluid dynamics (CFD) and the measurements for the supersonic, deceleration condition. The data in Figure 108 is for a data point in Figure 107 with a very

high vibratory stress. As can be seen, the excitation (distortion) increases dramatically at roughly 85% span, which is farther out on radius than either of the two measurement locations.

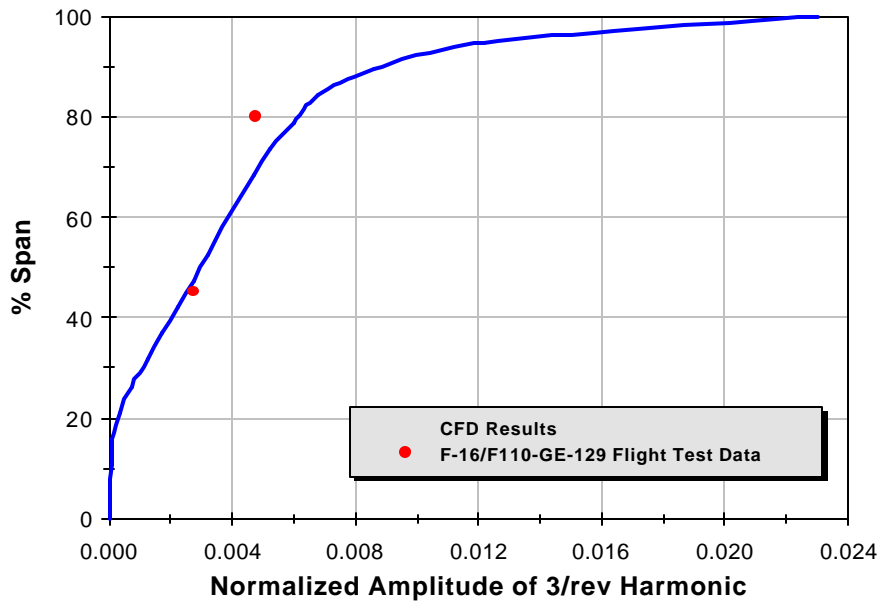

FIGURE 108. CFD Prediction and Measurements of 3/rev of Supersonic, Decel

To determine if this may be the cause of the two correlation trends seen in Figure 107, the radial distribution from the CFD results was matched to the data, and the MEI calculation was performed. The resulting MEI was increased by a factor of two to three. As seen in the modified correlation of Figure 109, this causes the supersonic, cruise data point (1a) of the upper curve to better match (Point 1b) the trend of the lower curve. This implies that the two correlation trends are due to some flight conditions having important distortion content in regions at higher radius than the measurements.

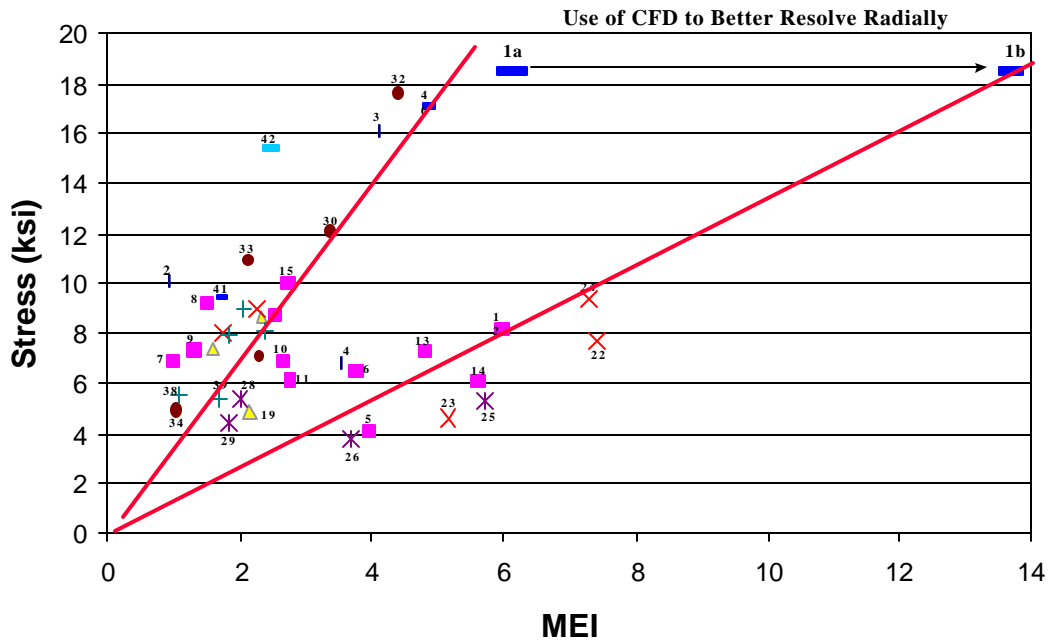

FIGURE 109. Modified Correlation between Vibratory Stresses and MEI

Recent Progress

No report was submitted in 2000. The information above was reported December 1999.

Participating Organizations: Aeromechanics Technology

Points of Contact:

Government

Dr. Douglas C. Rabe
U.S. Air Force, AFRL/PRTX
1950 Fifth St., Bldg. 18D
Wright-Patterson AFB, OH 45433-7251
Phone: (937) 255-6802 x231
Fax: (937) 255-0898
Email: douglas.rabe@terc.wpafb.af.mil

Contractor

Dr. Steven Manwaring
Aeromechanics Technology
Address:
GE Aircraft Engines
One Neumann Way MD-A413
Cincinnati, OH 45215
Phone: (513) 243-3428
Fax: (513) 243-8091
Email: steve.manwaring@ae.ge.com

8.8 Engine Structural Integrity Program (ENSIP) / Joint Service Specification Guide (JSSG) *FY 98-06*

Background

In 1998, an effort was undertaken at the recommendation of the Executive Independent Review Team (EIRT) to update JSSG-87231 and MIL-HDBK-1783A (the ENSIP Manual) by incorporating knowledge gained from the HCF Science and Technology Program. Three teams ("Analysis," "Testing," and "Materials") were formed to look into what changes were needed. The teams worked throughout 1998 and early 1999 formulating their recommendations. In mid-1999, the three teams made their recommendations for changes to the ENSIP Manual.

Recent Progress

In 2000, the recommendations from the teams were incorporated into the ENSIP Manual and reviewed by government and industry experts. After several iterations, the revised document was finished in December 2000. Some of the updates include new analyses for mistuning and damping, changes in testing procedures, and updated requirements on material properties. The update to the JSSG is to follow.

Participating Organizations: Air Force Research Laboratory (AFRL), Naval Air Systems Command (NAVAIR), NASA Glenn Research Center

Point of Contact:

Government

Mr. Vincent Spanel
U.S. Air Force, ASC/LPZ
2145 Monahan Way
Wright-Patterson AFB, OH 45433-7017
Phone: (937) 255-0657 x3327
Fax: (937) 255-8323
Email: vincent.spanel @wpafb.af.mil

8.9 Conclusion

As a result of the institution of the new Engine Demonstration Action Team and the overlap involved, one option under consideration is the dissolution of the Aeromechanical Characterization Action Team. If this action team is eliminated, most of the efforts previously managed by the Aeromechanical Characterization Action Team will be transferred to the Forced Response Action Team; the Passive Damping Action Team will manage the rest.

List of Acronyms

Acronym	Definition
ϵ -N	(epsilon-N) strain-life
AADC	Allison Advanced Development Company
ACIS	Advanced Compact Inlet System
AEDC	Arnold Air Development Center
AFDS	Air Film Damping System
AFOSR	Air Force Office of Scientific Research
AFRL	Air Force Research Laboratory
AIAA	American Institute of Aeronautics and Astronautics
AlN	Aluminum Nitride
AMT	Accelerated Mission Testing
AR	As Received
ASP	Automated Shot Peened
AT	Action Team
ATEGG	Advanced Turbine Engine Gas Generator
BDSP	Blade-Deflection Signal Processor
BTG	Blade Timing Generator (NSMS)
CAD	Computer Aided Design
CAESAR	Core and Engine Structural Assessment Research
CARL	Compressor Aerodynamics Research Laboratory
CDA	Controlled Diffusion Airfoil
CFD	Computational Fluid Dynamics
CLD	Constrained Layer Damping
CLDS	Constrained Layer Damping System
COPE	Controlled Operating Pressure Engine
COV	Coefficient of Variation
CRF	Compressor Research Facility
DUST	Dual Use Science and Technology
EDM	Electrical Discharge Machining
EIRT	Executive Independent Review Team
ENSIP	Engine Structural Integrity Program
ENSIP	Engine Structural Integrity Program
F/M	Fracture Mechanics
FE	Finite Element
FEA	Finite Element Analysis
FFT	Fast Fourier Transform
FOD	Foreign Object Damage
FS	Fatemi and Socie (model)
G4F	Generation 4 Front-End
G4M	Generation 4 (real-time) Monitoring (NSMS)
G4P	Generation 4 Processor
GE	General Electric
GE/CRD	General Electric Corporate Research and Development

List of Acronyms (Cont.)

GEAE	General Electric Aircraft Engines
GRC	Glenn Research Center (NASA)
GUIde	Government, University, Industry (consortium)
HCF	High Cycle Fatigue
HP	High Pressure
HPC	High Pressure Compressor
HPT	High Pressure Turbine
IAP	Industry Advisory Panel
IBR	Integrally Bladed Rotor
IFR	Initial Flight Release
IGV	Inlet Guide Vane
IHPTET	Integrated High Performance Turbine Engine Technology (Program)
IR&D	Independent Research and Development
ISSI	Innovative Scientific Solution Inc.
ITO	Indium Tin Oxide
JSF	Joint Strike Fighter
JSSG	Joint Service Specification Guide
JTDE	Joint Turbine Demonstrator Engine
LCF	Low Cycle Fatigue
LE	Leading Edge
LED	Light-Emitting Diode
LEFF	Low Excitation Front Frame (GE)
LIFTP	Laser Induced Fluorescence of Thermographic Phosphors
LP	Low Pressure
LPT	Low Pressure Turbine
LSP	Laser Shock Peening
LSPT	Laser Shock Peening Technologies (Inc.)
MEI	Model Excitation Index
NASA	National Aeronautics and Space Administration
NAWC	Naval Air Warfare Center
NDE	Non-Destructive Evaluation
NOPD	Non-Obstructive Particle Damping
NPS	Naval Postgraduate School
NSMS	Non-Contact Stress Measurement System
P&W	Pratt & Whitney
PDAS	Probabilistic Design Analysis System
PDF	Probability Density Function
PDR	Preliminary Design Review
PFN	Pulse-Forming Network
PIV	Particle Image Velocimetry
PIWG	Propulsion Instrumentation Working Group
POD	Proper Orthogonal Decomposition

List of Acronyms (Cont.)

PPL	Prototype Production Laser
PRDS	Probabilistic Rotor Design System
PSP	Pressure Sensitive Paint
PZT	Lead (Pb) Zirconate Titanate (piezoelectric material)
QA	Quality Assurance
QC	Quality Control
R	R ratio (minimum stress/maximum stress)
RIE	Reactive Ion Etching
ROM	Reduced Order Model(ling)
RPM	Revolutions per Minute
RVM	Rotational Vibration Monitoring
S&T	Science and Technology
SAW	Surface Acoustic Waves
SBA	Single Blade Analysis (NSMS)
SBIR	Small Business Innovative Research
SDRAC	Structural Dynamic Response Analysis Code (NSMS)
SE	Structural Engine
SiC	Silicon Carbide
SLS	Selective Laser Sintering
S-N	Stress-Life
SR	Stress Relieved
STOA	Solution Treated Over-Aged
SWAT	Sine Wave Analysis Technique (NSMS)
SWT	Smith-Watson-Topper (model)
T&E	Test and Evaluation
TACs	Total Accumulated Cycles
TBC	Thermal Barrier Coating
TEFF	Turbine Engine Fatigue Facility
TOA	Time of Arrival (of a blade)
TP	Thermographic Phosphor
TPT	Technical Plan Team
TSP	Temperature Sensitive Paint
UAV	Uninhabited Air Vehicle
UCSD	University of California at San Diego
UDRI	University of Dayton Research Institute
UK	United Kingdom
URI	University of Rhode Island
UTC	Universal Technology Corporation
VBIA	Vane-Blade Interaction Analysis
VEM	Viscoelastic Material