

REPORT DOCUMENTATION PAGE

AFRL-SR-BL-TR-01-

0382

Public reporting burden for this collection of information is estimated to average 1 hour per response, including the time for reviewing instruction data needed, and completing and reviewing this collection of information. Send comments regarding this burden estimate or any other aspect of this burden to Department of Defense, Washington Headquarters Services, Directorate for Information Operations and Reports (0704-0188), 12 4302. Respondents should be aware that notwithstanding any other provision of law, no person shall be subject to any penalty for failing to con valid OMB control number. PLEASE DO NOT RETURN YOUR FORM TO THE ABOVE ADDRESS.

1. REPORT DATE (DD-MM-YYYY) 30-04-2001	2. REPORT TYPE Final Technical	3. DATES COVERED (from - to) 01-10-1997 - 31-1-2001		
4. TITLE AND SUBTITLE Single-Electronics		5a. CONTRACT NUMBER		
		5b. GRANT NUMBER F496209810025		
		5c. PROGRAM ELEMENT NUMBER		
6. AUTHOR(S) Lukens, James E.; Averin, Dmitri V.; Likharev, Konstantin K.		5d. PROJECT NUMBER		
		5e. TASK NUMBER		
		5f. WORK UNIT NUMBER		
7. PERFORMING ORGANIZATION NAME(S) AND ADDRESS(ES) Research Foundation of SUNY SUNY at Stony Brook Stony Brook, NY 11794-3676		8. PERFORMING ORGANIZATION REPORT NUMBER		
9. SPONSORING / MONITORING AGENCY NAME(S) AND ADDRESS(ES) AFOSR Dir. of Physics & Electronics AFOSR/NE 801 N. Randolph St., Room 732 Arlington VA 22203-1977 USA		10. SPONSOR/MONITOR'S ACRONYM(S)		
		11. SPONSOR/MONITOR'S REPORT NUMBER(S)		
12. DISTRIBUTION / AVAILABILITY STATEMENT none				
20010625 160				
13. SUPPLEMENTARY NOTES				
14. ABSTRACT This project studied, both theoretically and experimentally, properties on single electron (SET) and single pair tunneling (SPT) devices. The main effort was the study of the potential application of SPT devices for quantum computation (QC). Experimentally, it was demonstrated that one type of SPT device, the Bloch Transistor (BT) could have a coherent superposition of the 0 and 1 pair state. Theoretically a number of approaches for the use of SPT devices in QC were examined. It was also shown that an SET device, properly bias could be an nearly quantum limited detect. An extensive, general analysis of the continuous measurement of quantum devices was made.				
15. SUBJECT TERMS				
16. SECURITY CLASSIFICATION OF: U		17. LIMITATION OF ABSTRACT	18. NUMBER OF PAGES 22	19a. NAME OF RESPONSIBLE PERSON
a. REPORT UU	b. ABSTRACT UU			c. THIS PAGE UU

I. EXECUTIVE SUMMARY

During the past decade, a new exciting field of physical and applied electronics has emerged. Its most common nickname is Single-Electronics. The physics of this field (for general reviews, see Refs. [1-4]) is based on the effects of correlated single-electron tunneling. Their essence is that transfer of single electrons (or single Cooper pairs) in systems of conducting (metallic, semiconductor, or molecular) "electrodes", connected by tunnel barriers of very small area, may be strongly correlated either in time, or in space, or both.

Since 1987, reliable evidence of correlated tunneling has been obtained in numerous experiments with normal-metal, superconductor, and semiconductor junctions and systems (for a recent collection of reviews, see Ref. [4]). These experiments have shown, in particular, that the "orthodox" theory of correlated tunneling [3] gives a quantitatively correct description of the experimental data for systems in which each conducting "electrode" contains many free electrons. As a consequence, this theory can be used to analyze possible practical applications of correlated single-electron tunneling.

Preliminary studies of this type [1,5,6] have shown that single-electronics may yield a completely new generation of both digital and analog devices with unparalleled performance. In addition, purely quantum phenomena in superconducting systems of ultra-small junctions promise a new range of unique capabilities.

Over the past several years there has been rapidly increasing interest in the unique promise of purely quantum circuits, e.g. quantum computation and secure communications, which have clear applications for DoD and the Air Force in particular. One of the first challenges for the realization of these quantum circuits is the development of qubits which have both a high degree of coherence and the possibility of assembly into large circuits. The latter requirement argues strongly in favor of solid state devices. In other approaches such as NMR, laser-cooled trapped ions or atoms in a cavity, nature easily provides coherence at the single qubit level. However, it appears that the obstacles to arranging such atomic or molecular qubits so that one can provide controllable coupling among a large enough number

for useful quantum computation is nearly insurmountable. The recent demonstrations of the coherent superposition of charge states in single pair tunneling (SPT) devices [7,8] such as the Bloch Transistor raise the very exciting possibility that SPT devices may well provide these qubits.

The key results of our work toward these goals under this grant are summarized below:

- We have achieved a definitive demonstration of the coherent superposition of charge states in a Bloch Transistor (BT) as required for its use as a qubit in a quantum computer.
- We have demonstrated the effective resistive isolation of a single junction as demonstrated by a Coulomb-blockade-induced reduction of over 4 orders of magnitude of current in the blockade region. In the blockade region for $eV > k_B T$ the current is essentially a power law in voltage with an exponent which depends on the isolating resistor and is theoretically equivalent to similar dependences which are now being reported in Luttinger liquids.
- SET devices have been successfully fabricated using our Nb trilayer technology. These SETs have by far the best characteristics so far reported for refractory metal SETs. Encouraged by these results, we plan to continue the development of this process as part of the proposed work.
- A concept for using RSFQ pulses for the control of a SPT qubit has been developed. In future quantum computation circuits, it may make qubit inversion operations much simpler and faster than the Rabi-oscillation methods suggested earlier. In particular, the SFQ pulse area quantization removes the necessity of precise control of the external signal timing.
- Coulomb blockade and macroscopic quantum tunneling of phase in high-transparency Josephson junctions have been analyzed. One result of this analysis is that not only the total barrier resistance but the microscopic structure of the tunnel barrier is relevant

for Coulomb blockade, which can exist only in junctions without pinholes. Another important conclusion of this work is that in nearly-ballistic junctions, the temperature-induced crossover from quantum to classical tunneling is continuous and does not have a definite crossover temperature as in tunnel junctions

- The adiabatic transport of Cooper pairs in Josephson junction arrays has been analyzed. Calculations of pumping accuracy show that better than 1 ppm accuracy can in principle be achieved with arrays of 5-7 junctions. For shorter arrays, however, quantum leakage of Cooper pairs is quite strong and precludes accurate pumping.
- A theory has been developed for the continuous monitoring of the quantum coherent charge oscillations. We have shown that because of the dephasing introduced by the measuring device, the maximum signal-to-noise ratio in continuous direct monitoring of quantum coherent oscillations is 4.
- We have analyzed quantum-detector characteristics of a SET transistor in the resonant-tunneling regime biased at the Coulomb blockade threshold. For this optimum bias, the transistor energy sensitivity is shown to be equal to $\hbar/\sqrt{3}$, i.e., is very close to the fundamental quantum limit.

Both our observation of the coherence of charge states in the BT and the development of a number of concepts essential for the use of SPT devices as qubits in quantum computation lay a solid foundation for expanded research toward this goal.

II. KEY RESULTS OF THE WORK SUPPORTED BY THIS GRANT.

A. Band gap measurements and observation of coherent states in Bloch Transistors.

Daniel J. Flees, J. E. Lukens and Siyuan Han [7].

We have extended our previous measurements [9,12] of the band gap in Bloch transistors in two important ways. These measurements are made by detecting a microwave-induced

depression in the current I_s at which the transistor switches to the running, or finite voltage, state. This depression occurs when the photon energy of the microwaves E_p is just equal to the gate-charge dependent gap E_g between the energy bands of the transistor. Figure 1 shows the results of such a measurement vs. gate charge for a fixed value of the microwave frequency. Since the gap is a minimum at $Q = 1 \text{ mod}(2)$ and increases monotonically as $Q \rightarrow 0$, one sees a depression in I_s at Q which extends along the Q axis until $E_g > E_p$. In Fig. 1, one sees an additional area of depressed I_s around $Q = 0$. This is interpreted as being due to two photon excitation to the second excited band since I_s is depressed to a value nearly equal to that of this band rather than the much lower I_s of the first excited band. The gap as a function of Q is then mapped out by repeating these measurements for different values of E_p . These data were taken on a symmetric transistor, i.e. one in which the junctions have equal critical currents. For such a transistor, the gap energy measured is purely electrostatic, going to zero for odd integer Q .

An even more interesting case is that of the asymmetric Bloch transistor where, at $Q = 0$, where a residual gap is predicted due to the coherent mixing of charge states by the Josephson coupling energy. This system, near $Q = 0$, is a prototype of the spin 1/2 system which serves as the model for qubits in quantum computation. Figure 2 shows the measured $E_g(Q)$ for a Bloch transistor with an asymmetry of about 1:2.5 between the junctions. The residual gap at $Q = 0$ due to the energy difference between the symmetric and antisymmetric combinations of the charge states is clearly seen and provides a definitive demonstration of the coherent superposition of charge states in a Bloch Transistor (BT) as required for use as a qubit in a quantum computer. Extending these results to understand this system and develop the BT has a qubit has become the main focus of our present experimental effort on this project and for the proposed work discussed below.

B. Measurement of voltage dependence of the blockade current in a single isolated junction.

Wei Zheng, J. R. Friedman, D. V. Averin, Siyuan Han, and J. E. Lukens [16,17].

Most SET experiments have been done in junction pairs (transistors) where the junctions provide natural isolation of each other from the environment. In contrast, a single junction must be isolated from the environment by, e.g. resistors, in order for Coulomb blockade to be seen. Even though the original theory of Coulomb blockade was for single junctions, and interesting SET logic families based on resistively isolated junctions have been analyzed, until this work, strong blockade in a single junction had not been observed. The reason for this is that one must have isolation resistors R which satisfy $R \gg R_Q$ while still having a length of less than several microns. If this is not done, the resistor will be capacitively shunted and no longer provide effective isolation. An example of the current - voltage characteristic of a single, isolated junction is seen in Fig. 3. Here, one sees a low voltage blockade current which is reduced by four orders of magnitude over that for the unisolated junction. The $I - V$ curve is well fit by the theory of resistive isolation over the six orders of magnitude in current shown. In the blockade region for $eV > k_B T$ this theory is essentially a power law in voltage with an exponent which depends on the isolating resistor and is theoretically equivalent to similar dependences which are now being reported in Luttinger liquids.

C. Development of SET transistors using niobium trilayer technology.

Daniel J. Flees, Wei Chen, and J. E. Lukens [18,19]

So far work on metal SETs has been largely confined to Al junctions, which can be fabricated with relative ease using self-aligned masking techniques. As with Josephson electronics, e.g. RSFQ, it is important to migrate to a more robust technology such as Nb trilayers which will permit more complex circuits to be fabricated that will be stable

over time and thermal cycling. For superconducting SET circuits such as Bloch transistors, Nb has another very important advantage — a much larger gap energy Δ . Since one must have $E_c < \Delta$ for Bloch transistors, the larger gap permits much smaller junctions with higher operating temperatures and larger signal voltages.

During this past year, we have upgraded our PARTS process for Nb circuits to the point where we have been able to fabricate the first high quality SET transistors made using Nb junctions. Figure 4 shows the $I - V$ curves of one such Nb transistor in the superconducting (upper panel) and normal (lower panel) states. This transistor has junctions with areas of about $0.01 \mu\text{m}^2$ and a normal state resistance of $340 \text{ k}\Omega$. The lower panel in fig. 4 shows the normal $I - V$ curves for gate charges of $Q = 0$ and $Q = e/2$, exhibiting the full range of modulation. While we have made Nb junctions this small and even smaller in the past, the key to our present results is to use electron beam lithography to pattern all process layers. This is essential since the base electrode and wiring layer, as well as the counter electrode, must be small in order that a large parasitic capacitance not degrade the operation of the transistor. Figure 5 shows the noise power spectrum of a transistor with somewhat smaller junctions and so a larger transfer function (inset). This noise level is not dramatically larger than that seen in Al transistors. This is important since one might worry that the SiO_2 which is used to planarize the circuit and thus surrounds the junctions would have charge traps leading to a greatly increased noise level. With these data, we have now demonstrated that niobium trilayer technology is a viable process for the fabrication of SET devices. There were, however, two ways in which these first generation Nb BTs were inferior to the Al BTs which we have been using. First, the noise level is somewhat greater ($10^{-3} e/\sqrt{\text{Hz}}$) than our Al devices. Second, the apparent capacitance, obtained from the voltage modulation with gate charge, was about 10X greater than that expected from the known specific capacitance of the junctions plus the calculable parasitic capacitance from the lead. Even with these initial problems, the prospects for Nb SETs seem quite encouraging. We expect to pursue this development and address these issues as part of our proposed work.

D. RSFQ for Qubit Manipulation

K. K. Likharev

Unique properties of the Bloch transistor arise due to the macroscopic quantum interference of an infinite number of low-energy states of Josephson phase φ . The distance between the adjacent states is 2π , corresponding to a magnetic flux difference of $\Phi_0 = h/2e$. The fundamental nature of this difference creates an interesting opportunity to crossbreed the Bloch transistors with another type of Josephson junction devices, RSFQ digital circuits. These circuits can generate, transfer, control, and detect “SFQ” voltage pulses $V(t)$ with an exactly quantized area $\int V(t)dt = \Phi_0$. As we have shown (theoretically so far), this quantization creates an opportunity to manipulate the qubit states and also measure their decoherence rate.

Figure 6 shows the system considered. An RSFQ circuit sends a train of SFQ pulses to a large “driver” Josephson junction. Each pulse changes the Josephson phase ϕ_0 across the driver (and hence across the transistor) by 2π . Figure 7 shows the Josephson (“potential”) energy U of the transistor as a function of ϕ and ϕ_0 . The lower solid line shows a typical stationary value of ϕ_0 ($\approx \pi/4$), fixed by a dc bias current flowing through the driver junction. The island phase ϕ may have essentially quantum-mechanical behavior. As a result, the quantum mechanical interference of the eigenstates localized at the potential energy minima ($\varphi \approx 2\pi n$) creates extended eigenfunctions, which are responsible for the qubit properties of the transistor.

An SFQ pulse arriving from the driver shifts the line of fixed ϕ_0 by 2π (shown by the arrow in Fig. 7 almost instantly, on the scale of a few picoseconds. As Fig. 7 shows, this shifts the location of the energy minima on the axis of ϕ by π . Our analysis has shown that this rapid shift depopulates the lower state of qubit, and populates its higher state. In the weak coupling limit, $E_J \ll E_c$, this population inversion may approach 100%, if the external charge at the island (which may be controlled by an external gate voltage) is close to e .

This picosecond-scale population inversion creates several interesting and important op-

portunities.

1. In future quantum computation circuits, it may provide qubit inversion operations much simpler and faster than the Rabi-oscillation methods suggested earlier. In particular, the SFQ pulse area quantization removes the necessity of precise control of the external signal timing.

2. In preliminary studies of Cooper-pair qubits, SFQ pulse insertion may provide an effective tool for decoherence rate measurements. For this, the Bloch transistor should be weakly coupled to a single-electron transistor (serving as a low-frequency high-resolution electrometer) - see Fig. 6.

We are presently preparing experimental studies of these phase-biased BTs, which would continue as part of this proposal.

E. Coulomb blockade in high-transparency Josephson junctions.

D. V. Averin [33]

The aim of this work was to develop a quantitative theory of Coulomb blockade in Josephson junctions with arbitrary electron transparency, and in particular to establish whether Coulomb blockade takes place in fully-transparent junctions with ballistic electron transport. Although this question is mainly of conceptual interest, it is also important for Coulomb blockade applications of high-transparency niobium tunnel junctions and semiconductor/superconductor heterostructures. The developed theory showed that Coulomb blockade is completely suppressed in ballistic Josephson junctions, while the junction resistance remains on the order of quantum resistance, and Coulomb blockade would still exist in a tunnel junction of comparable resistance. The fundamental significance of this result is that it shows that Coulomb blockade requires for its existence not only localization of the total charge of the superconductor by an insulating resistance, but also finite degree of localization of individual electrons. In practice, this result means that not only the total barrier resistance but the microscopic structure of the tunnel barrier is relevant for Coulomb

blockade, which can exist only in junctions without pinholes.

F. Macroscopic quantum tunneling of phase in high-transparency Josephson junctions.

D.V. Averin [34].

Josephson junctions with high critical current density and associated high electron transparency are currently attracting considerable attention due to their potential applications in superconducting electronics and due to non-trivial mechanisms of charge transport in these junctions where electrons are transferred by cycles of multiple Andreev reflections (MAR). Atomic point contacts fabricated with the controllable break-junction technique allow the study in detail of the dynamics of the Josephson phase difference in the high-transparency junctions in the MAR regime, and provide very accurate comparison between the theory and experiments. Until now, both the theory and experiment have focused on classical phase dynamics. During the past year, we have studied theoretically quantum tunneling of phase in high-transparency junctions. It was shown that in the nearly-ballistic junctions, the temperature-induced crossover from quantum to classical tunneling is continuous and does not have a definite crossover temperature as in tunnel junctions.

G. Adiabatic transport of Cooper pairs in Josephson junction arrays.

D.V. Averin [35]

Quantum computation requires precise manipulation of the states of quantum logic gates. The only solid-state proposal of quantum gates that allow for sufficient precision utilizes adiabatic manipulation of individual Cooper pairs or flux quanta in arrays of Josephson junctions. In the case of Cooper pairs, such a precise adiabatic transport is useful as a basis for the fundamental current standard even in the absence of phase coherence required for quantum computation. As a first step towards the goal of accurate pumping of Cooper pairs in arrays of junctions we have developed a computational scheme of quantitative description

of this pumping. The scheme is based on the derived quantum mechanical formula for induced current and allows us to take into account possible non-uniformities of the array parameters and external resistances that are required in practice to suppress quasiparticles. Calculations of pumping accuracy show that better than 1ppm accuracy can in principle be achieved with arrays of 5-6 junctions.

The fundamental limitations on the pumping accuracy are associated with the quantum tunneling of Cooper pairs. The two contributions to this tunneling come in the form of direct supercurrent flow through the junction array and Cooper pair tunneling out of the propagating potential well created by the gate voltages. We have calculated both contributions for uniform arrays with arbitrary number N of junctions. The calculations are performed analytically in the case of small Josephson coupling energies and numerically for arbitrary coupling energies. The developed numerical code can also be used to study non-uniform arrays. The main conclusion of our calculations is that the quantum leakage of Cooper pairs is quite strong and precludes accurate pumping in short arrays ($N=3$) for all realistic coupling energies. In larger arrays, $N=5-7$, the pumping accuracy can reach a level acceptable for their applications in metrology and quantum computing.

H. Continuous monitoring of the quantum coherent oscillations.

A.N. Korotkov and D.V. Averin [37], D.V. Averin [38,39], A.N. Korotkov [40].

The concept of continuous measurement provides a detailed dynamic description of interaction between the measured system and a detector, and allows one to characterize quantitatively the quantum measurement process and detector characteristics. We have studied continuous weak measurement of quantum coherent dynamics of an individual qubit within the generic model of a linear detector. The main results of this work is the demonstration that for a symmetric detector, the signal-to-noise ratio of the measurement, defined as the ratio of the amplitude of the oscillation line in the output spectrum to background noise, is independent of the coupling strength between oscillations and the detector, and is equal

to $(\hbar/\epsilon)^2$, where ϵ is the detector energy sensitivity. The fundamental quantum limit of 4 imposed by this result on the signal-to-noise ratio of the measurement with an “ideal” quantum-limited detector reflects the general tendency of a quantum measurement to localize the system in one of the eigenstates of the measured observable. We applied these results explicitly to specific measurements of the quantum oscillations of magnetic flux with a dc SQUID, and oscillations of charge measured with a Cooper-pair electrometer. An important by-product of the established relation between the energy sensitivity and the signal-to-noise ratio is the calculation of the energy sensitivity of a quantum point contact used as detector in experiments with quantum dot qubits. The quantum point contact is shown to be the quantum-limited detector with the fundamental energy sensitivity $\hbar/2$.

I. SET transistor as a quantum detector.

D.V. Averin.

The standard detector for measurements of charge dynamics in systems of mesoscopic tunnel junctions is the single-electron tunneling (SET) transistor. Until now, the transistor properties as a quantum detector have been analyzed only at large bias voltages when the current flow through the transistor is due to regular single-electron tunneling. In this high-voltage regime the transistor generates large shot noise, which led to the conclusion that the SET transistor is not a quantum-limited detector. We have analyzed quantum-detector characteristics of the SET transistor in the resonant-tunneling regime biased at the Coulomb blockade threshold. For this optimum bias, the transistor energy sensitivity is shown to be equal to $\hbar/\sqrt{3}$, i.e., is very close to the fundamental limit. This means that the transistor introduces noise in the dynamics of the measured qubit that is only marginally larger than the fundamental noise required by the quantum mechanics of measurement, and can be used in the quantum computing circuits.

III. PUBLICATIONS.

The publications and theses resulting from work done as part of this grant are references [7,16–19,33–43]

IV. SCIENTIFIC PERSONNEL.

The following scientific personnel worked on this project.

Prof. James Lukens, PI

Prof. Dmitri Averin, Co-PI

Prof. Konstantin Likharev, Co-PI

Dr. Sergey Tolpygo

Dr. Sasha Korotkov

Dr. V. Ponomarenko

Dr. Alex Guillaume

Dr. Alec Maassen Vanden Brink

Wei Zheng

Stephen Deus

Vijay Patel

J. Reiner

Jaan Mannik

REFERENCES

- [1] K.K. Likharev, "Correlated Discrete Transfer of Single Electrons in Ultrasmall Tunnel Junctions", IBM J. Res. Devel. **32**, 144-158 (1988).
- [2] Michael Tinkham, *Introduction to Superconductivity*, (McGraw-Hill, New York, 1996) , Chap. 7.
- [3] D.V. Averin and K.K. Likharev, "Single-Electronics", in: *Mesoscopic Phenomena in Solids*, ed. B. Altshuler, P. Lee, and R. Webb (Elsevier, Amsterdam, 1991), p. 173
- [4] *Single Charge Tunneling*, ed. H. Grabert and M. Devoret (Plenum, New York, 1992).
- [5] K.K. Likharev, "Single Electron Transistors: Electrostatic Analogs of DC SQUIDS", IEEE Trans.Magn. **23**, 1142-5 (1987).
- [6] D.V. Averin and K.K. Likharev, "Possible Applications of the Single Charge Tunneling", in: *Single Charge Tunneling*, ed. by H. Grabert and M.H. Devoret (Plenum, New York, 1992), pp. 311-332.
- [7] Daniel J. Flees and Siyuan Han and J. E. Lukens, "Observation of Coherent Charge-State Mixing in Asymmetric Bloch Transistors", Jour. Supercond. **12**, 813 - 817 (1999).
- [8] Y. Nakamura, Y. A. Pashkin, and J. S. Tsai, "Coherent Control of Macroscopic Quantum States in a Single-Cooper-Pair Box", Nature **398**, 786-788 (1999).
- [9] D. J. Flees, Siyuan Han, and J.E. Lukens, "Interband Transitions and Band Gap Measurements in Bloch Transistors", Phys. Rev. Lett, **78**, 4817-4820 (1997)
- [10] D.V. Averin, A.B. Zorin and K.K. Likharev, "Bloch Oscillations in Small Josephson Junctions", Sov. Phys. JEPT **61** 2, (1985)
- [11] K.K. Likharev, "Coexistence of Bloch and Josephson Effects in Small-Area Layered Superconducting Structures" Publ. 29/1986 Moscow State Univ. (1986).
- [12] D.J. Flees and J.E. Lukens, "Compact Multichannel Microwave Filters for Cryogenic

- Applications”, private communication (1997)
- [13] John Marinis, Michel H. Devoret, and John Clarke, “Experimental tests for the quantum behavior of a macroscopic degree of freedom: The phase difference across a Josephson junction”, *Phys. Rev. B*, **35**, 4682 (1987).
- [14] M. Tuominen, J. Hergenrother, T. Tighe, and M. Tinkham, *Phys. Rev. Lett.* **69**, 1997 (1992).
- [15] A. Amar, D. Song, C. Lobb, and F. Wellstood, *Phys. Rev. Lett.* **72**, 3234 (1994).
- [16] Wei Zheng, Siyuan Han, and J.E. Lukens, “Coulomb Blockade in Resistively Isolated Single Junctions”, *Solid State Comm.*, **108**, 839 -843 (1998).
- [17] Wei Zheng, Ph. D. thesis, SUNY-Stony Brook, unpublished (1999)
- [18] Daniel, J. Flees, Ph. D. thesis, SUNY-Stony Brook, unpublished (1998)
- [19] W. Chen, Daniel, J. Flees, Jonathan R. Friedman, Vijay Patel, J. Mannik, and J. E. Lukens, “Nb-based single-electron devices fabricated using a planarized process”, *ISEC’99-Extended Abstracts*, 315-317, (Berkeley, 1999)
- [20] Z. Bao, M. Bhushan, S. Han, and J.E. Lukens, “Fabrication of High Quality, Deep-Submicron Nb/ AlO_x /Nb Josephson junctions using Chemical Mechanical Polishing”, *IEEE Trans. Appl. Superconductivity*, **5**, 2731 (1995).
- [21] M.B. Ketchen, et al., “Sub- μm , planarized, Nb- AlO_x -Nb Josephson process for 125 mm wafers developed in partnership with Si technology”, *Appl. Phys. Lett.*, **59**, 2609 (1991).
- [22] K.A. Matsuoka, K.K. Likharev, P. Dresselhaus, L. Ji, S. Han, and J.E. Lukens, “Single Electron Traps: A Quantitative Comparison of Theory and Experiment”, *J. Appl. Phys.* **81**, 2269 (1996).
- [23] P.D. Dresselhaus, L. Ji, Siyuan Han, J.E. Lukens, and K.K. Likharev, “Measurement of Single Electron Lifetimes in a Multi-Junction Trap”, *Phys. Rev. Lett.* **72**, 3226 (1994).

- [24] K.K. Likharev and A.N. Korotkov, "Single-electron Parametron: Reversible Computation in a Discrete-state System", *Science* **273**, 763 (1996).
- [25] K.K. Likharev and A.N. Korotkov, "Single-electron Parametron", paper in preparation.
- [26] D.V. Averin, A.N. Korotkov, A.J. Maninen, and J.P. Pekola, *Phys. Rev. Lett.*, **78**, 4821 (1997).
- [27] R. Rouse, Siyuan Han, and J.E. Lukens, "Observation of Resonant Tunneling between Macroscopically Distinct Quantum Levels", *Phys. Rev. Lett.* **75**, 1614 (1995).
- [28] Siyuan Han, R. Rouse, and J.E. Lukens, "Generation of a Population Inversion between Quantum States of a Macroscopic Variable", *Phys. Rev. Lett.* **76**, 3404 (1996).
- [29] A.N. Korotkov, D.V. Averin, K.K. Likharev, and S.A. Vasenko, in: *Single-Electron Tunneling and Mesoscopic Devices*, ed. by H. Koch and H. Li
- [30] T.A. Fulton, P.L. Gammel, D.J. Bishop, L.N. Dunkleberger, and G.J. Dolan, *Phys. Rev. Lett.* **63**, 1307 (1989).
- [31] Y. Nakamura, C.D. Chen, and J.S. Tsai, "Spectroscopy of energy-level splitting between two macroscopic charge states coherently superposed by Josephson coupling", preprint (1997).
- [32] D.V. Averin, "Adiabatic quantum computation with Cooper pairs", *Solid State Commun.*, **105**, 657 (1998).
- [33] D.V. Averin, "Coulomb blockade in superconducting point contacts", *Phys. Rev. Lett.*, **82**, 3685 (1999)
- [34] D.V. Averin, "Quantum dynamics of superconducting point contacts: chiral anomaly, Landau-Zener transitions, and all that", *Superlattices and Microstructures*, **25**, 891 (1999).
- [35] J. P. Pekola, J. J. Toppari, M. Aunola, M. T. Savolainen and D. V. Averin, "Adiabatic

- transport of Cooper pairs in arrays of Josephson junctions”, *Phys. Rev. B*, **60**, R9931 (1999).
- [36] D.V. Averin, “Quantum computing with mesoscopic Josephson junctions”, *Chaos* **10**, 1679 (1999)
- [37] A. N. Korotkov and D. V. Averin, “Continuous weak measurement of quantum coherent oscillations”, preprint, cond-mat0002203.
- [38] D.V. Averin, “Continuous weak measurement of the macroscopic quantum oscillations”, preprint, cond-mat0004364,
- [39] D.V. Averin, “Quantum computing and quantum measurement with mesoscopic Josephson junctions”, *Fortschrit. der Physik* **48**, 1055 (2000).
- [40] V.V. Ponomarenko and D.V. Averin, “Coulomb drag between one-dimensional conductors”, *Phys. Rev. Lett.* **85**, 4928 (2000).
- [41] A.N. Korotkov, “Selective quantum evolution of a qubit state due to continuous measurement”, *Phys. Rev. B* **63**, 115403 (2001).
- [42] A.N. Korotkov, “Output spectrum of a detector measuring quantum oscillations”, *Phys. Rev. B* **63**, 085312 (2001).
- [43] A.N. Korotkov, “Correlated quantum measurement of a solid-state qubit”, preprint, cond-mat/0008003.

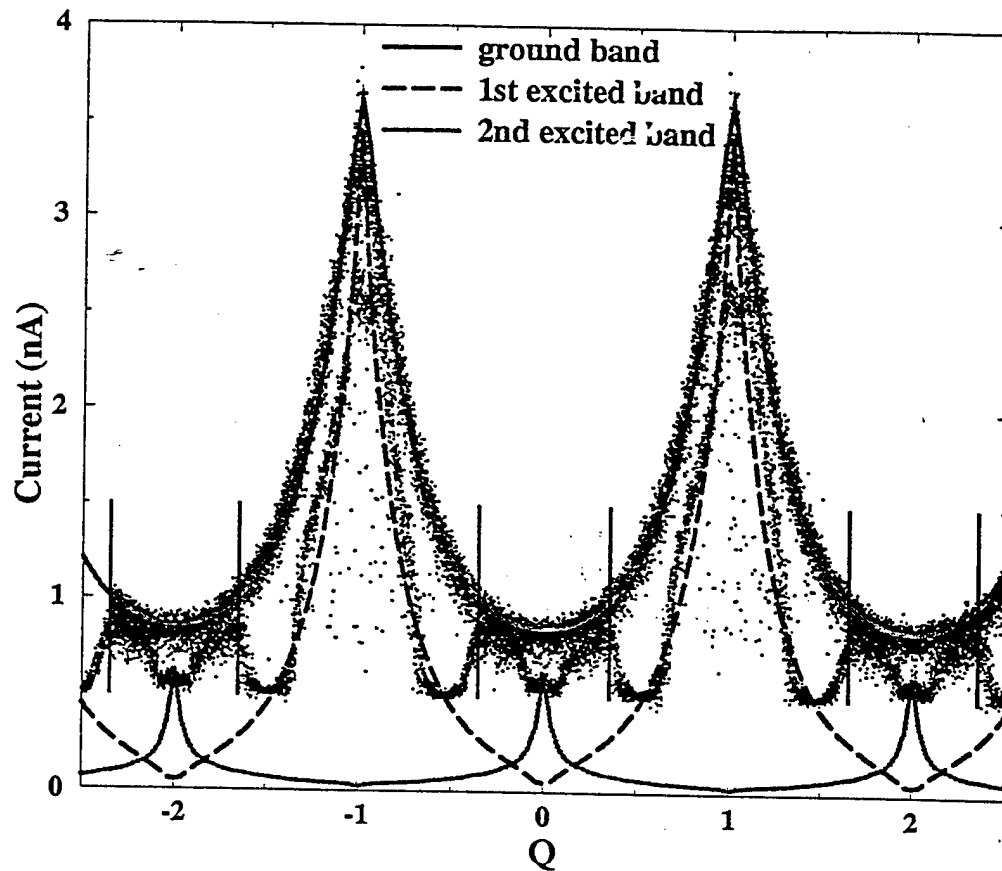

Figure 1. The effects of 28 GHz irradiation on the switching current modulation of sample BT9. The raw data with and without irradiation are shown with the fit to the energy band calculations (solid and dashed lines) achieved using the empirical relationship between switching current and critical current.

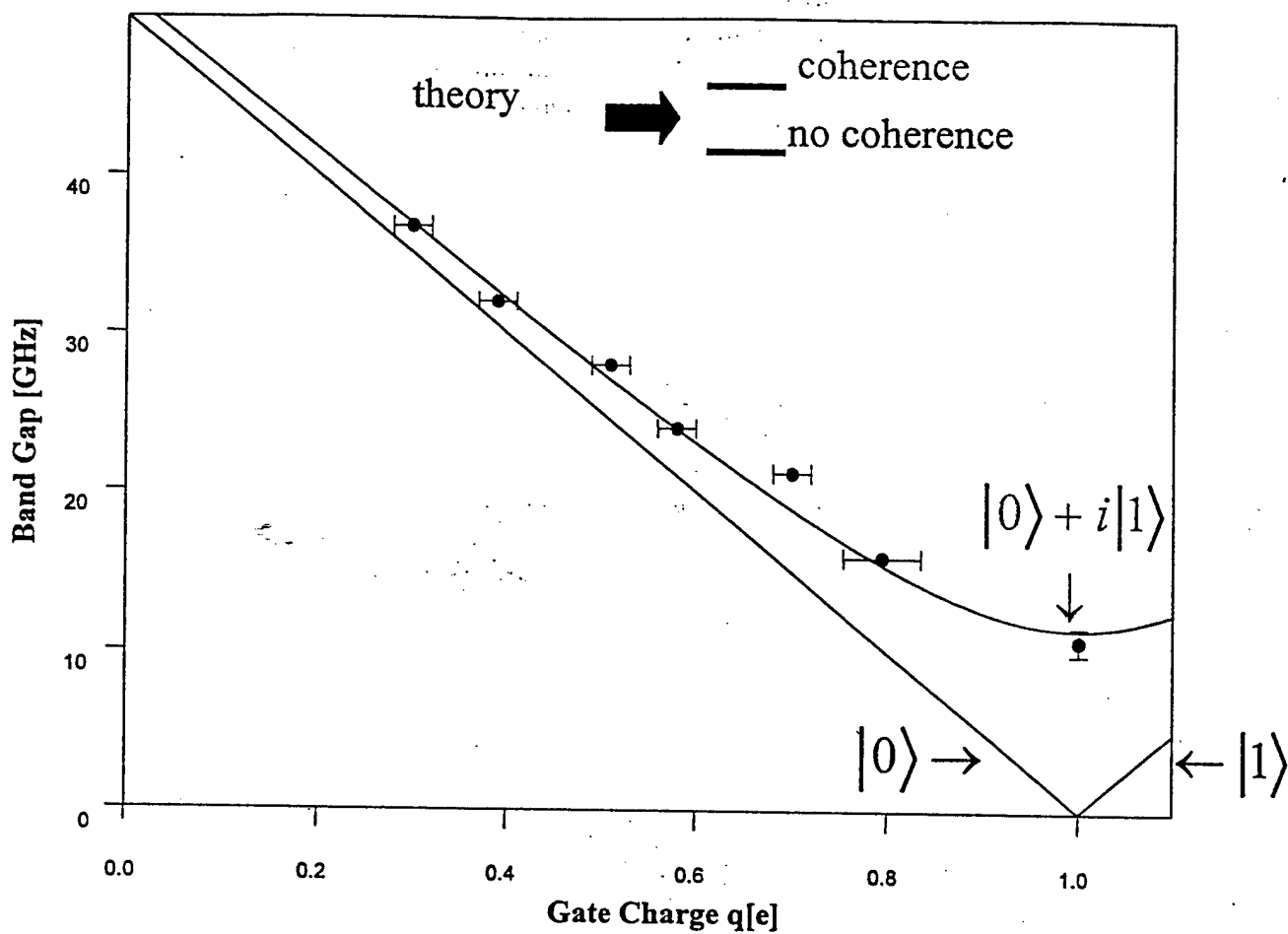

Figure 2. The measured band gap for asymmetric transistor AST2. The error bars are attributable primarily to fluctuations in the background charge (Q') and are estimated based on measurements over several modulation periods. The solid line is a fit to theory using the measured junction asymmetry. The dashed line is the expected band gap for a symmetric transistor with equivalent charging energy.

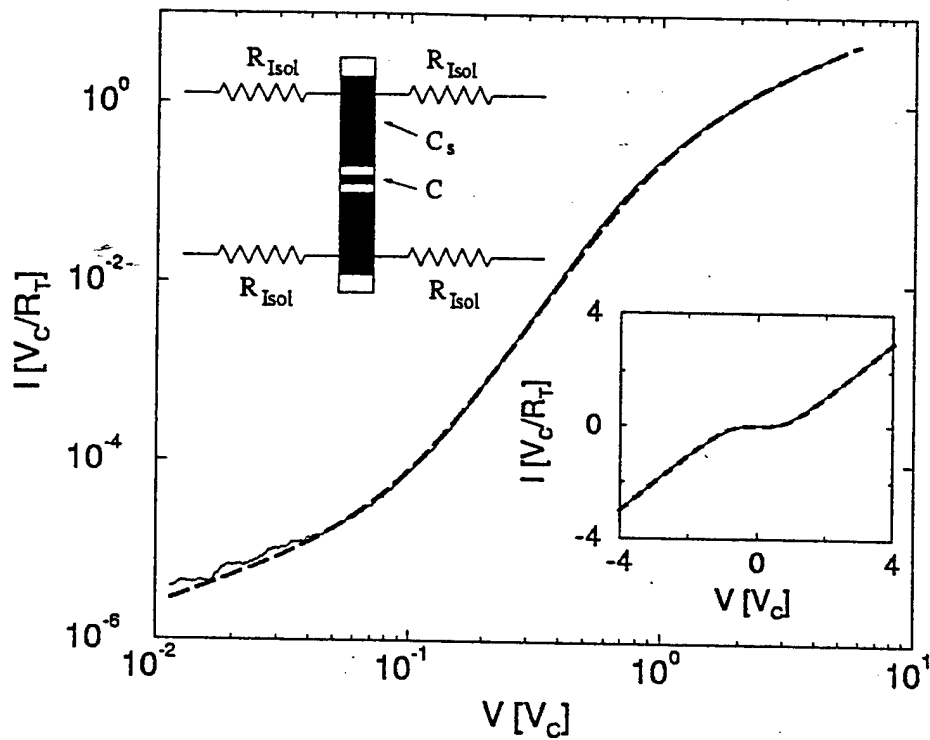

Figure 3. I - V characteristics (thin solid line) of sample at 70 mK compared with theoretical fit (thick dashed line) using R_{isol} as a free parameter. The upper inset shows the schematic of the sample, where the dark areas are the overlapping regions formed by the Al shadow evaporation with the darkest areas representing the junctions. The lower inset gives the linearly scaled I - V curve and the associated fit.

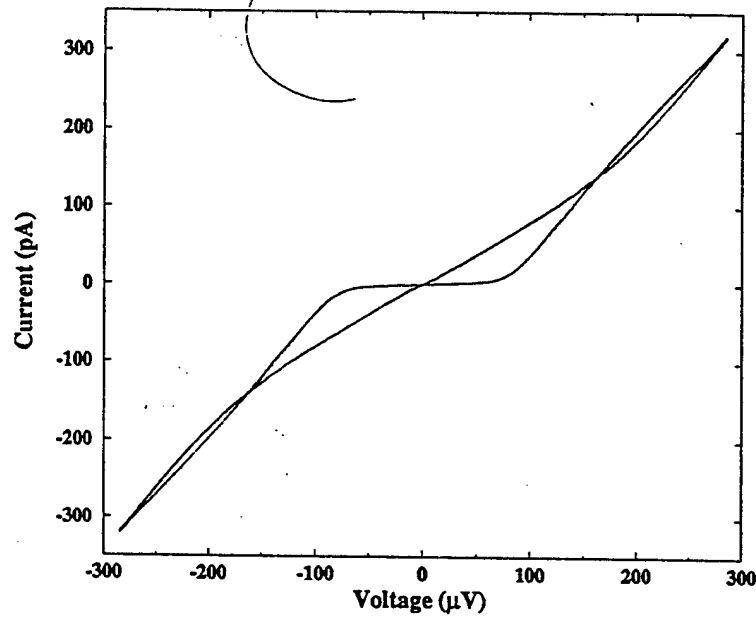
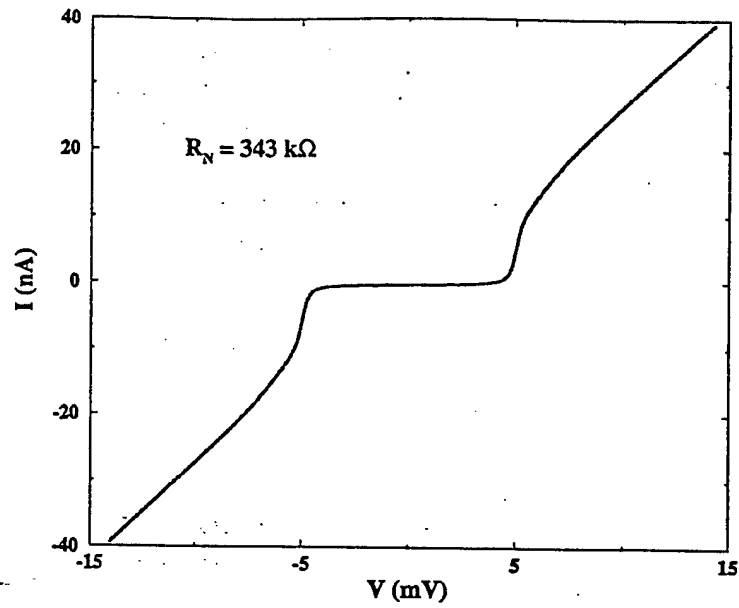

Figure 4 Superconducting (top) and normal state (bottom) IV characteristics for a low capacitance Nb/AlO_x/Nb transistor. The normal state IV curves correspond to the minimum and maximum Coulomb blockade.

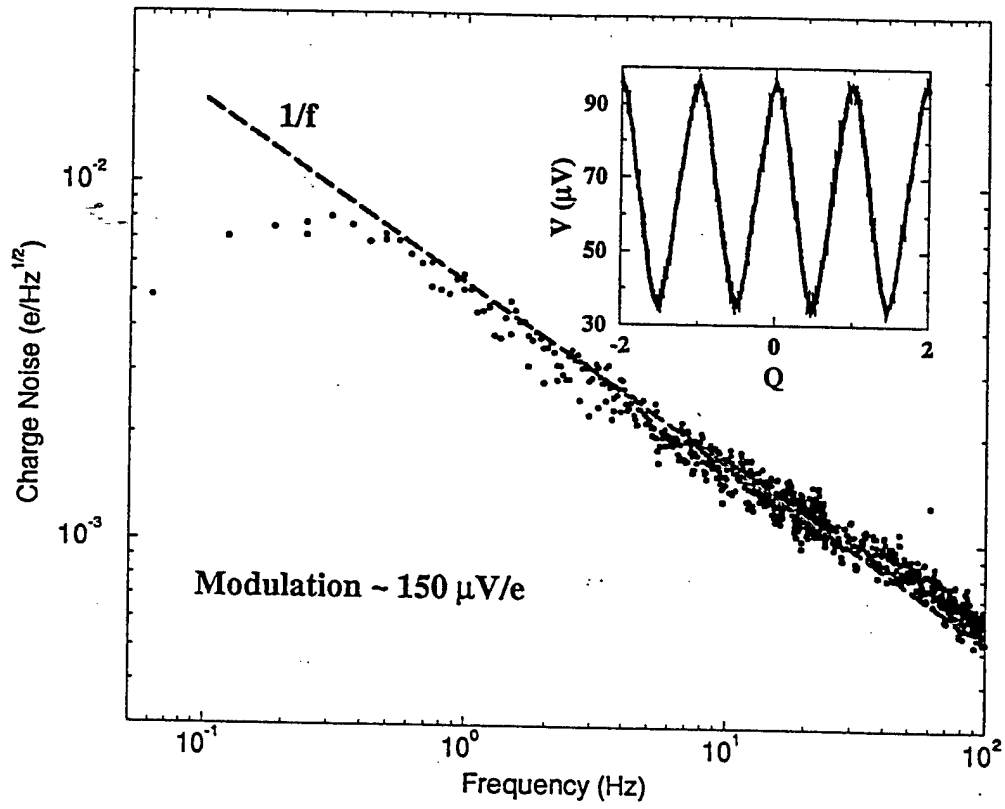

Figure 5 Measured transistor charge noise with an applied 4 Tesla magnetic field to suppress superconductivity. The modulation transfer function in the most sensitive region ($Q = 0.25$) is about $150 \mu\text{V}/e$ (inset). The dashed line demonstrates a $1/f$ power spectrum.

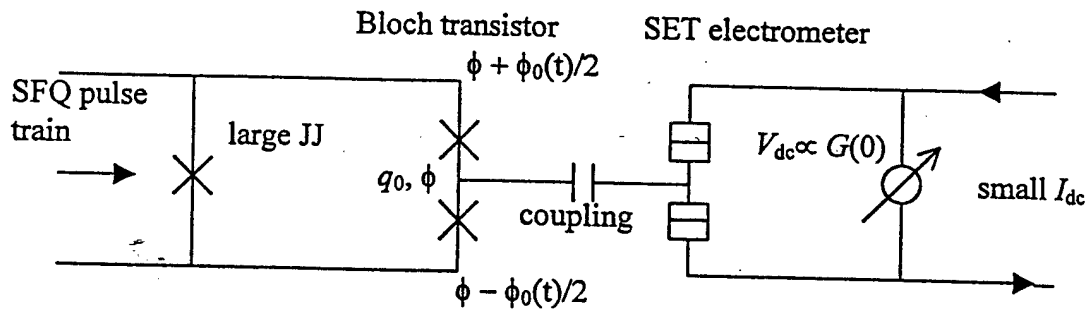

Figure 6. Scheme of the RSFQ-assisted manipulation with Cooper pair qubits

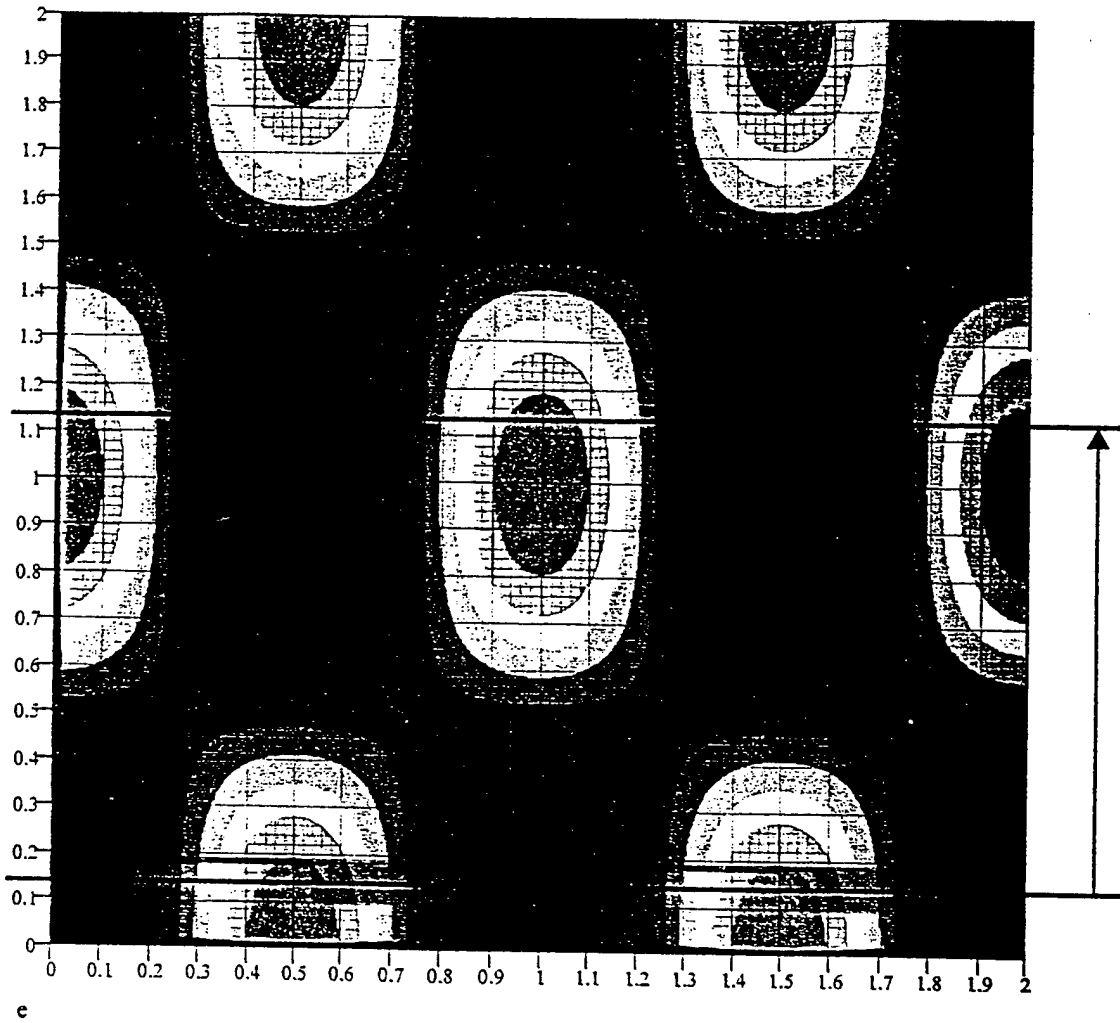

Figure 7. Potential (Josephson) energy U of the Bloch transistor as a function of $\phi/2\pi$ (horizontal axis) and $\phi_0/2\pi$ (vertical axis). Red colors correspond to the highest values of U , while blue colors to the lowest. The arrow shows the shift of ϕ_0 resulting from a single SFQ pulse.