

O

H

S

D

**A Digital Recording System
for Shock Induced Motion**

Andrew McLean
and Phillip Box

DSTO-TN-0339

A Digital Recording System for Shock Induced Motion

Andrew McLean and Phillip Box

**Maritime Platforms Division
Aeronautical and Maritime Research Laboratory**

DSTO-TN-0339

ABSTRACT

A digital data recording system capable of recording signals from various types of transducers used to measure shock motion is described. The methods used to maximise the flexibility of the recording system and the methodology to optimise the data obtained is explained.

20010711 115

Approved for Public Release

DEPARTMENT OF DEFENCE
DEFENCE SCIENCE & TECHNOLOGY ORGANISATION

DSTO

AQ F01-10-1763

Published by

*DSTO Aeronautical and Maritime Research Laboratory
506 Lorimer St
Fishermans Bend Vic 3207 Australia*

*Telephone: (03) 9626 7000
Fax: (03) 9626 7999*

*© Commonwealth of Australia 2001
AR- 011-799
March 2001*

APPROVED FOR PUBLIC RELEASE

A Digital Recording System for Shock Induced Motion

Executive Summary

Full-scale shock testing of naval platforms requires many channels of data to characterise the shock environment to which the platform is subjected and the response of the platform structure and components to the induced shock. To adequately cope with the shock testing of the Minehunter Coastal and the Collins class submarine additional acquisition capacity was required. This requirement was met by the procurement of a data acquisition system manufactured by Pacific Instruments Inc. based in California, USA

Modifications to the acquisition system have made the system very versatile and methodologies developed have maximised the usefulness of data acquired. The system complements MPD's high-speed shock measurement capability.

Contents

1. INTRODUCTION.....	1
2. SYSTEM HARDWARE	1
2.1 The Series 5500 Enclosure	1
2.2 The 5530-3 Channel Modules	3
3. SOFTWARE CONTROL.....	4
3.1 Acquisition Module.....	4
3.2 Acquisition Rate.....	5
3.3 Acquisition Initiation.....	6
3.4 Acquisition Control	6
3.5 Data Display.....	7
3.6 Data Manipulation.....	7
4. CALIBRATION	8
4.1 Voltage Calibration.....	8
4.2 Resistive Shunt Calibration	8
5. OPERATIONAL USE	9
5.1 Operational Philosophy.....	9
5.2 Triggering and Time Correlation.....	9
6. CONCLUSION	10
7. REFERENCES.....	10

1. Introduction

Full-scale shock testing of naval platforms requires many channels of data to characterise the shock environment to which the platform is subjected and the response of the platform structure and components to the induced shock. Maritime Platforms Division had a capacity of 30 channels of high-speed data acquisition suitable for recording the shock environment produced by underwater detonations and shock induced motion. To adequately cope with the shock testing of the Minehunter Coastal and the Collins class submarine additional capacity was required. This requirement was met by the procurement of a data acquisition system manufactured by Pacific Instruments Inc. based in California, USA.

The requirement for the data acquisition system included the ability to record data from different types of transducers without the need for additional hardware, to record data in a manner easily analysed, and to be synchronised with other instrumentation and the explosives firing systems.

This paper describes the data acquisition system procured, the modifications implemented to optimise its capabilities and flexibility and the methodology employed during the shock trials to maximise the usefulness of the data obtained.

2. System Hardware

2.1 The Series 5500 Enclosure

The acquisition system procured was the Pacific Instruments, series 5500 with 5530-3 acquisition modules.

The series 5500 enclosure provides for 16 channels of transducer signal acquisition. The enclosure houses the power supplies required for the unit itself and the excitation for the transducers, the computer interface hardware, all the connectors for the transducers and a channel control module. The acquisition modules are accessed via the front panel of the enclosure. The modules each consist of two printed circuit boards that slide into the enclosure, mating with the motherboard.

The system was capable of providing the constant current excitation required for Integrated Circuit Piezo-electric (ICP) transducers but needed an additional external power supply. The power supply required was a simple current limited DC supply. The majority of the transducers used with the system were ICP. To more easily cater for these transducers a power supply was installed within the enclosure.

The enclosure includes a channel control module, which is a microprocessor-based system that controls the settings on the acquisition modules and the timing of the data acquisition from each module. These acquisition module settings are stored in non-volatile memory on the channel controller. These settings are read by the microprocessor when first turned on and each acquisition module is programmed with

the last used settings. The microprocessor then acts on any subsequent commands sent to the channel modules from the computer.

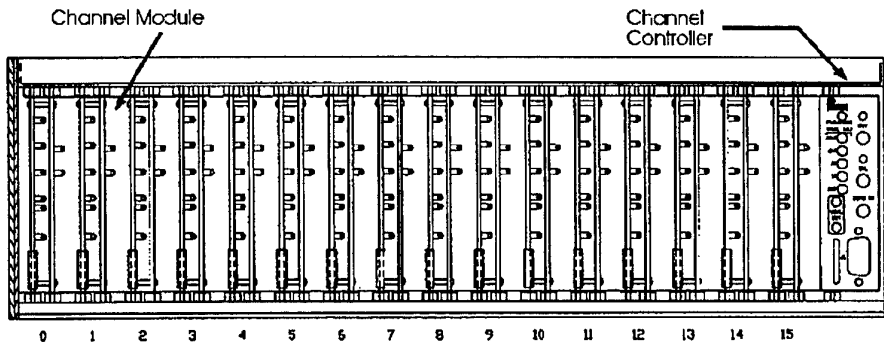

Figure 1 Front View of 5500 Enclosure Showing Acquisition Modules

All channels sample data from the transducers continuously. The channel controller controls data flow from the acquisition modules to the computer. Data is acquired according to the acquisition sequence programmed, see section 3.2. The maximum data throughput is dependent on the computer interface used, which in this case is the IEEE-488 General Purpose Interface Bus (GPIB). It is possible to sample all 16 modules at a maximum sampling rate of 30 kHz. Up to 10 cards can be used at a maximum sampling rate of 50 kHz.

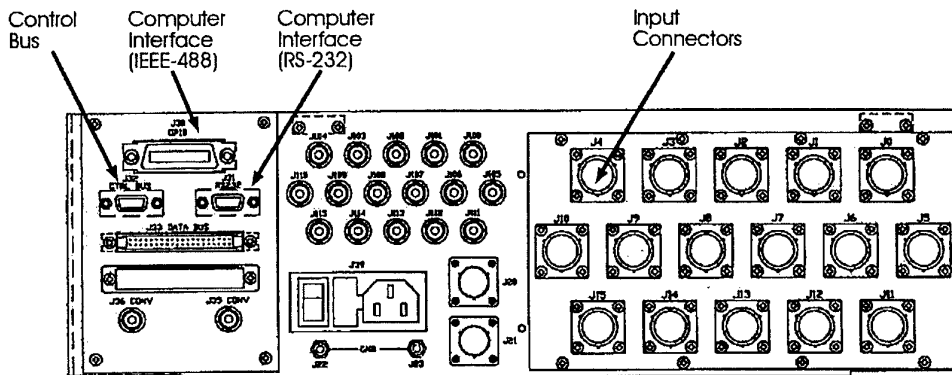

Figure 2 Rear View of 5500 Enclosure Showing Connectors

All connections including those for the transducers and the computer interface are located on the rear panel of the enclosure. The connections for the transducers are a 10-pin cannon type connector suitable for many transducer variations. Predominantly these units are used with either ICP or Piezo-resistive transducers requiring a 2-wire

coaxial connection or a 5-wire two twisted-pair shielded connection respectively. Adaptor connections have been manufactured as shown in Figure 3.

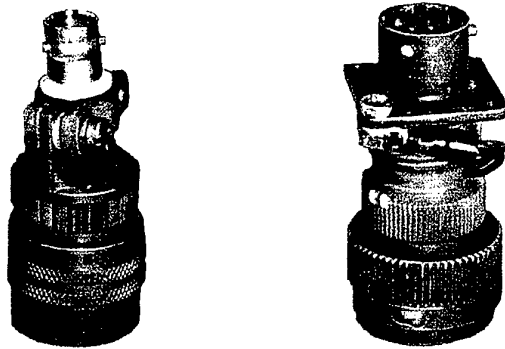

Figure 3 Connection Adaptors

2.2 The 5530-3 Channel Modules

A large range of acquisition modules was available. Channel modules 5530-3 were chosen.

Each 5530-3 acquisition module contains the entire signal processing elements needed to support one channel of data. It provides excitation for the transducer, either constant current or constant voltage, signal amplification, analogue filtering (low pass), and analogue to digital conversion. Transducer types including $\frac{1}{4}$, $\frac{1}{2}$ and full resistive bridges, strain gauges, potentiometers, RTD's, and piezo-electric can be accommodated as well as simple voltage signals.

The modules have selectable gains from 1 to 1000, selectable six-pole anti-aliasing filters with cut-off frequencies of 625, 1250, 2500 and 5000 Hz and a broadband frequency response of 10 kHz. The module has a 16-bit analogue to digital converter with a maximum conversion frequency of 50 kHz. Automated features include the balancing of the channel when the unit is initially turned on and whenever gain or filter settings are programmed.

Figure 4 shows one side of the acquisition module. The small switches shown in the picture are the result of modifications to allow the quick re-configuration of the cards for differing requirements. Prior to these modifications solder links had to be installed or removed to appropriately configure the card for the transducer type used. Figure 4 shows a quick reference guide to the switch settings for different transducer types.

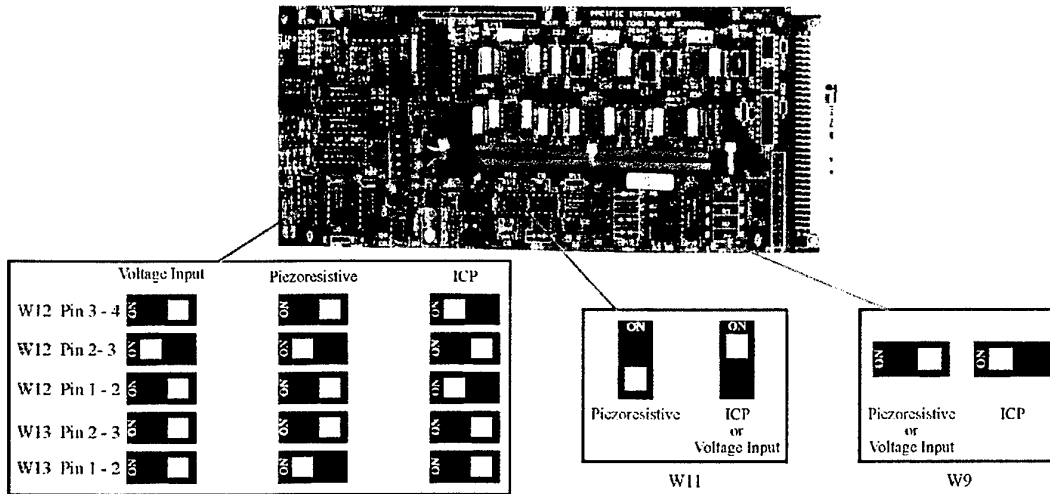

Figure 4 Channel Module Showing Additional Switches

3. Software Control

The acquisition system is controlled using a personal computer. Proprietary software provides the user interface with communications between the computer and the acquisition system utilising the GPIB. The software is MS Windows compatible. Numerous dialogue boxes are available but the main ones are described below. The configurations are selected by simply pointing and clicking the computer mouse on the appropriate buttons, check boxes and drop down boxes.

3.1 Acquisition Module

Figure 5 shows the dialogue box that allows the operator to configure the acquisition module. All available software programmable module settings are programmed using this dialogue box. Some entries are simply text descriptors. The name entered is used as the name of the file when data files are created. Critical settings such as the transducer sensitivity and the selected gain are used to calculate the value of the stored data in engineering units.

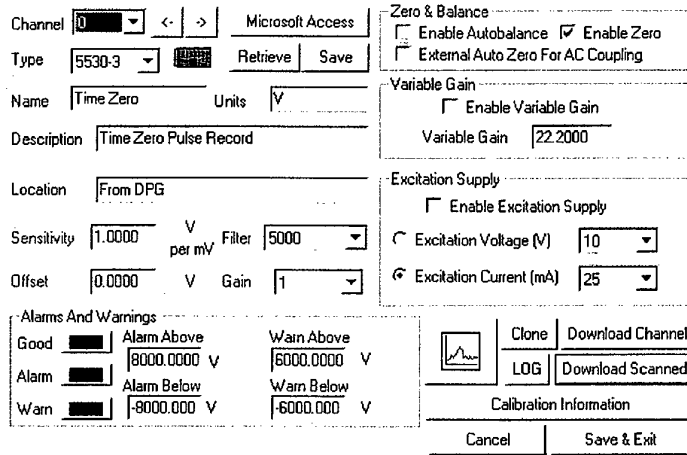

Figure 5 Acquisition Module Configuration Dialogue Box

3.2 Acquisition Rate

Each channel of data can be sampled at different rates, although in most applications data are acquired at the same rate for all channels. Figure 6 shows the dialogue box through which the channels required are selected along with the required acquisition rates.

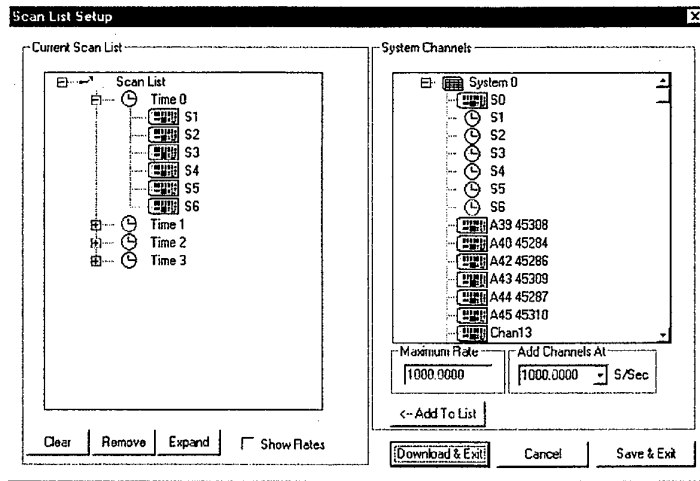

Figure 6 Scan list dialogue box for selecting modules and the acquisition rate

3.3 Acquisition Initiation

The system can be configured to “record” from numerous trigger sources. These include the software control panel, a signal through the communications port, or a level on one of the acquisition channels. Recording can be stopped by similar signals or after a preset time after the trigger. These options are selected using the Recording Options dialogue box shown in Figure 7. The example shown indicates the system will be initiated from an external trigger signal and record for 2 seconds.

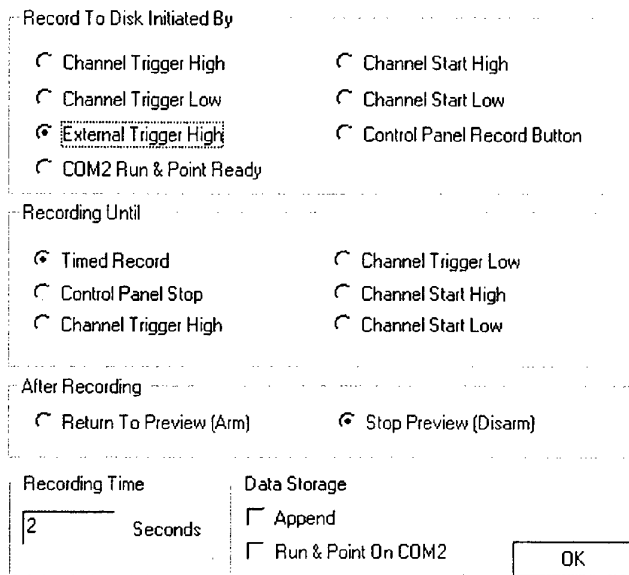

Figure 7 Recording Options Dialogue Box

3.4 Acquisition Control

Control of the acquisition and the display of recorded data utilises a dialogue box devised to look like a tape recorder control panel as shown in Figure 8. The digits in the display indicate elapsed time since the start of the recording. When using a trigger source as indicated in Figure 7, the system has to be started or “Armed” using the Control Panel by clicking the preview button (the horizontal bar). The system then acquires data but does not store data until the trigger signal is received.

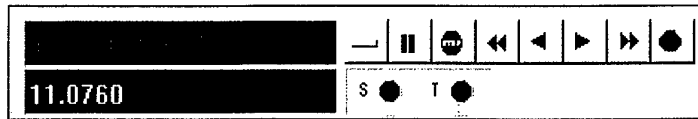

Figure 8 Record & Playback Control Panel

3.5 Data Display

Signals can be viewed on the computer screen using various display types. These displays include bar charts, numerical read-outs and oscilloscope-style views. Figure 9 shows numerous oscilloscope-style displays of recorded data. Each of these screens can be enlarged to the full screen size for detailed viewing.

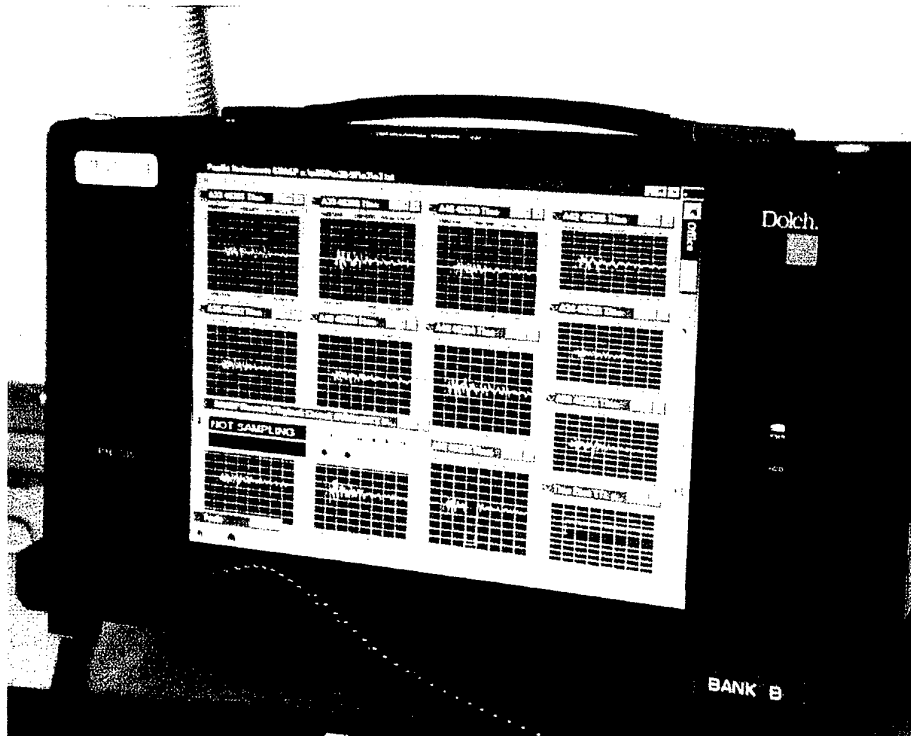

Figure 9 Oscilloscope-Style Display of Data

3.6 Data Manipulation

After recording, the data can be converted to a number of different data formats including ASCII. The ASCII file header shown in Figure 10 lists various parameters, which are entries in the acquisition module configuration dialogue box, and then the data in two columns: time and acquired data in engineering units. This enables detailed analysis using software packages such as Origin®.

```
Datafile for Channel 0 Test: c:\pi660\si5-98\im1(17)tension\im1(17)
tension.tst
Name: S1
Units: uE
"Description: Strain Gauge 1, IM1(17)"
Location:
Gain: 200.0000
Filter Cutoff (Hz): 625.0000
TIME:::::::::::::DATA:::::::::::::
0                23.456716
0.1              23.456716
0.2              23.456716
0.3              23.456716
0.4              18.763134
0.5              18.763134
```

Figure 10 Header and beginning of data from an ASCII data file

4. Calibration

Maritime Platform Division's shock and shock motion transducers are routinely calibrated with reference to NATA standards. The calibration of the acquisition systems is routinely conducted to ensure that measurements are traceable to NATA standards. There are two types of calibration used with this acquisition system.

4.1 Voltage Calibration

When commercial transducers are used to measure physical properties, the transducers are calibrated using prescribed equipment and procedures that ensure the sensitivity of the transducer is accurately known. These procedures are documented elsewhere.[1,2,3]

The calibration of the acquisition system is accomplished using a NATA certified AC voltage source and acquiring data using each acquisition module configured for each of its selectable gain settings. The channel modules have proven to be very reliable and accurate with acquired data being within one-half of a percent of the calculated values over the whole range of gains.

This calibration process is regularly conducted, at least every year, and before any large or significant data acquisition task. To date the accuracy of the modules has been very consistent.

4.2 Resistive Shunt Calibration

Strain data is acquired using this system. Due to the inherent properties of strain gauges and the Whetstone Bridge completion circuits the most appropriate method of

calibrating for strain measurements is to calibrate the whole system in situ prior to the data acquisition. To accomplish this the Whetstone Bridge has a shunt resistor connected across one arm of the bridge. A shunt resistor is a very accurate resistor of known resistance and the connection generates a signal with an equivalent strain calculated using the resistance values. The software for the Pacific Instruments system has routines specifically for this purpose. The simplest calibration is performed by acquiring data with no shunt resistor to establish a zero level and then connecting a shunt resistor over one leg of the Whetstone Bridge and acquiring more data. Variations include repeating the process a number of times or using a number of different shunt resistances. The data acquired during this process is then used to calculate the sensitivity for the whole acquisition system consisting of the strain gauge the Whetstone Bridge and the acquisition module.

5. Operational Use

5.1 Operational Philosophy

The Pacific Instruments acquisition system provides a capability to record some shock-induced motion of platforms and equipment. It does not have the bandwidth suitable for the characterisation of shock environments in water or air nor does it have the bandwidth for acquisition of shock waves in materials. Other acquisition systems are used for these purposes. The Pacific Instruments system is, however, a flexible acquisition system that complements acquisition systems capable of characterising the shock environment. Utilising two systems with different acquisition rates in concert provides a powerful capability in recording the shock environment and shock-induced motion.

5.2 Triggering and Time Correlation

Maritime Platform Division utilises electronic units called delay pulse generators to synchronise instrumentation and explosive initiation. These units provide numerous electronic signals at selectable delays with accuracy better than 1 microsecond.

Many digital data acquisition systems have accurate trigger systems that can be used to synchronise the data acquired with external events. The Pacific Instruments system does not. There is no accurate time correlation between a signal received on the external trigger connection and the data acquired. When using the Pacific Instruments system for shock work where time correlation is required the system is normally triggered half a second before the detonation and one of the acquisition modules is used to record a time signal coincident with the detonation of the explosives. This is a compromise between having accurate time referenced data and reducing the number of data channels to 15 for each system. The 15 channels of data subsequently have the

time data corrected so as zero time in the data file is when the explosives were detonated.

6. Conclusion

The procurement of the Pacific Instruments system increased Maritime Platform Division's shock motion measurement capability. The modifications have made the acquisition system very versatile and methods used maximise the usefulness of the data acquired. The system complements the high-speed shock measurement capability. When used together they permit the recording of up to 60 channels of shock data.

7. References

- 1 Calibrating Air Blast Transducers with the PCB Dynamic Pressure Pulse Calibrator. Andrew McLean and Phillip Box. DSTO-TN-0278, Defence Science and Technology Organisation, May 2000
- 2 Dynamic Impulse Calibration of 100 Mpa Blast Pressure Transducers, Frank Marian and Phillip Box (DSTO report in publication)
- 3 Calibrating Accelerometers for Shock Measurement. Andrew Krelle (DSTO report in publication)

DISTRIBUTION LIST

A Digital Recording System for Shock Induced Motion

Andrew McLean and Phillip Box

AUSTRALIA

DEFENCE ORGANISATION

Task sponsor

S&T Program

Chief Defence Scientist
FAS Science Policy
AS Science Corporate Management
Director General Science Policy Development
Counsellor Defence Science, London (Doc Data Sheet)
Counsellor Defence Science, Washington (Doc Data Sheet)
Scientific Adviser to MRDC Thailand (Doc Data Sheet)
Scientific Adviser Policy and Command
Navy Scientific Adviser (Doc Data Sheet and distribution list only)
Scientific Adviser - Army (Doc Data Sheet and distribution list only)
Air Force Scientific Adviser
Director Trials

} shared copy

Aeronautical and Maritime Research Laboratory

Director

Chief of Maritime Platforms Division
Research Leader Surface Platform Systems
Author(s): Mr. Andrew McLean
Mr. Phillip Box

Mr. Paul Elischer
Mr. Frank Marian
Mr. Andrew Krelle
Mr. Darren Wiese

DSTO Library and Archives

Library Fishermans Bend (Doc Data Sheet)
Library Maribyrnong (Doc Data Sheet)
Library Salisbury
Australian Archives
Library, MOD, Pyrmont (Doc Data sheet only)
US Defense Technical Information Center, 2 copies
UK Defence Research Information Centre, 2 copies
Canada Defence Scientific Information Service, 1 copy
NZ Defence Information Centre, 1 copy

Capability Systems Staff

Director General Maritime Development

Director General Aerospace Development (Doc Data Sheet only)

Knowledge Staff

Director General Command, Control, Communications and Computers (DGC4)
(Doc Data Sheet only)

Director General Intelligence, Surveillance, Reconnaissance, and Electronic Warfare (DGISREW) R1-3-A142 CANBERRA ACT 2600 (Doc Data Sheet only)

Director General Defence Knowledge Improvement Team (DGDKNIT)
R1-5-A165, CANBERRA ACT 2600 (Doc Data Sheet only)

Navy

SO (SCIENCE), Catherine MORGAN, COMAUSNAVSURFGRP, BLD 95, Garden Island, Locked Bag 12, PYRMONT NSW 2009 (Doc Data Sheet and distribution list only)

Army

Stuart Schnaars, ABCA Standardisation Officer, Tobruk Barracks, Puckapunyal, 3662(4 copies)

SO (Science), Deployable Joint Force Headquarters (DJFHQ) (L), MILPO Gallipoli Barracks, Enoggera QLD 4052 (Doc Data Sheet only)

NPOC QWG Engineer NBCD Combat Development Wing, Tobruk Barracks, Puckapunyal, 3662 (Doc Data Sheet relating to NBCD matters only)

Intelligence Program

DGSTA Defence Intelligence Organisation

Manager, Information Centre, Defence Intelligence Organisation

Corporate Support Program

Library Manager, DLS-Canberra

UNIVERSITIES AND COLLEGES

Australian Defence Force Academy

Library

Head of Aerospace and Mechanical Engineering

Hargrave Library, Monash University (Doc Data Sheet only)

Librarian, Flinders University

OTHER ORGANISATIONS

NASA (Canberra)

AusInfo

OUTSIDE AUSTRALIA

ABSTRACTING AND INFORMATION ORGANISATIONS

Library, Chemical Abstracts Reference Service
Engineering Societies Library, US
Materials Information, Cambridge Scientific Abstracts, US
Documents Librarian, The Center for Research Libraries, US

INFORMATION EXCHANGE AGREEMENT PARTNERS

Acquisitions Unit, Science Reference and Information Service, UK
Library - Exchange Desk, National Institute of Standards and Technology, US

SPARES (5 copies)

Total number of copies: 42

DEFENCE SCIENCE AND TECHNOLOGY ORGANISATION DOCUMENT CONTROL DATA				1. PRIVACY MARKING/CAVEAT (OF DOCUMENT)		
2. TITLE A Digital Recording System for Shock Induced Motion			3. SECURITY CLASSIFICATION (FOR UNCLASSIFIED REPORTS THAT ARE LIMITED RELEASE USE (L) NEXT TO DOCUMENT CLASSIFICATION) Document (U) Title (U) Abstract (U)			
4. AUTHOR(S) Andrew McLean and Phillip Box			5. CORPORATE AUTHOR Aeronautical and Maritime Research Laboratory 506 Lorimer St Fishermans Bend Vic 3207 Australia			
6a. DSTO NUMBER DSTO-TN-0339		6b. AR NUMBER AR- 011-799		6c. TYPE OF REPORT Technical Note		7. DOCUMENT DATE March 2001
8. FILE NUMBER 510/207/1108	9. TASK NUMBER RDS 99/077	10. TASK SPONSOR DSTO	11. NO. OF PAGES 10		12. NO. OF REFERENCES 3	
13. URL on the World Wide Web http://www.dsto.defence.gov.au/corporate/reports/DSTO-TN-0339.pdf				14. RELEASE AUTHORITY Chief, Maritime Platforms Division		
15. SECONDARY RELEASE STATEMENT OF THIS DOCUMENT <i>Approved for Public Release</i>						
16. DELIBERATE ANNOUNCEMENT No Limitations.						
17. CASUAL ANNOUNCEMENT Yes						
18. DEFTEST DESCRIPTORS Measurement Technology, Calibration, data recording, Transducers, Shock mechanics						
19. ABSTRACT A digital data recording system capable of recording signals from various types of transducers used to measure shock motion is described. The methods used to maximise the flexibility of the recording system and the methodology to optimise the data obtained is explained.						

TECHNICAL NOTE DSTO-TN-0339 AR 011-799 MARCH 2001