

LOAN DOCUMENT

PHOTOGRAPH THIS SHEET

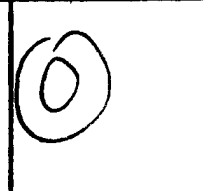

INVENTORY



LEVEL

DTIC ACCESSION NUMBER

Work Plan for the Eval. of Soil Vapor ...

DOCUMENT IDENTIFICATION

Jul 96

DISTRIBUTION STATEMENT A
Approved for Public Release
Distribution Unlimited

DISTRIBUTION STATEMENT

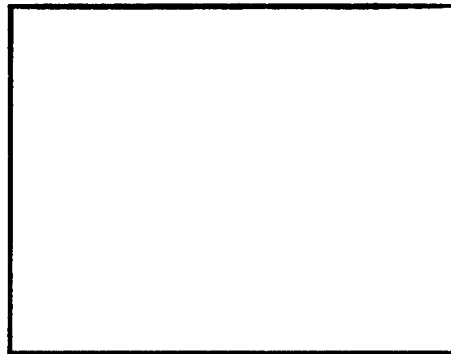

DATE ACCESSIONED



DATE RETURNED

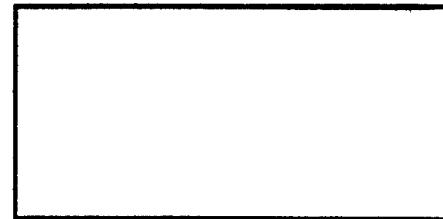

REGISTERED OR CERTIFIED NUMBER

ACCESSION FOR	
NTIS	GRAM <input checked="" type="checkbox"/>
DTIC	TRAC <input type="checkbox"/>
UNANNOUNCED	<input type="checkbox"/>
JUSTIFICATION	
BY	
DISTRIBUTION/	
AVAILABILITY CODES	
DISTRIBUTION	AVAILABILITY AND/OR SPECIAL
A-1	

DISTRIBUTION STAMP

20010716 118

DATE RECEIVED IN DTIC

H
A
N
D
L
E

W
I
T
H

C
A
R
E

PHOTOGRAPH THIS SHEET AND RETURN TO DTIC-FDAC

FINAL

**WORK PLAN FOR THE EVALUATION OF
SOIL VAPOR EXTRACTION USING
INTERNAL COMBUSTION ENGINE TECHNOLOGY
AT SITE SS-42
LUKE AIR FORCE BASE, ARIZONA**

Prepared for:

**AIR FORCE CENTER FOR ENVIRONMENTAL EXCELLENCE
TECHNOLOGY TRANSFER DIVISION
BROOKS AIR FORCE BASE
SAN ANTONIO, TEXAS
AND
56 CES/CEV
LUKE AFB, ARIZONA**

July 1996

Prepared by

**PARSONS ENGINEERING SCIENCE, INC.
1700 BROADWAY, SUITE 900
DENVER, CO 80290**

FINAL

**WORK PLAN FOR THE EVALUATION OF
SOIL VAPOR EXTRACTION USING
INTERNAL COMBUSTION ENGINE TECHNOLOGY
AT SITE SS-42
LUKE AIR FORCE BASE, ARIZONA**

Prepared for:

**AIR FORCE CENTER FOR ENVIRONMENTAL EXCELLENCE
TECHNOLOGY TRANSFER DIVISION
BROOKS AIR FORCE BASE
SAN ANTONIO, TEXAS
AND
56 CES/CEV
LUKE AFB, ARIZONA**

July 1996

Prepared by

**PARSONS ENGINEERING SCIENCE, INC.
1700 BROADWAY, SUITE 900
DENVER, CO 80290**

TABLE OF CONTENTS

	Page
SECTION 1 - INTRODUCTION.....	1-1
SECTION 2 - SITE DESCRIPTION.....	2-1
2.1 Site History.....	2-1
2.1.1 Background.....	2-1
2.1.2 Previous Investigations.....	2-1
2.2 Site Geology and Hydrogeology.....	2-5
2.3 Nature and Extent of Contamination.....	2-5
2.3.1 Groundwater Quality.....	2-5
2.3.2 Soil Quality.....	2-5
2.3.3 Soil Gas.....	2-5
SECTION 3 - INTERNAL COMBUSTION ENGINE TREATMENT TECHNOLOGY.....	3-1
3.1 Vapor Extraction and Combustion.....	3-1
3.1.1 System Description.....	3-1
3.1.2 Regulatory Acceptance.....	3-4
SECTION 4 - PILOT TEST ACTIVITIES.....	4-1
4.1 Pilot Test Design.....	4-1
4.1.1 Layout of Pilot Test Components.....	4-1
4.1.1.1 Extraction Wells.....	4-3
4.1.1.2 Monitoring Points.....	4-3
4.1.1.3 Piping System.....	4-3
4.2 ICE System Testing.....	4-3
4.2.1 Phase 1 - Startup and System Optimization.....	4-3
4.2.2 Phase 2 - Extended Operation and Performance Evaluation.....	4-4
4.2.3 System Monitoring.....	4-6
4.3 Demobilization.....	4-6
SECTION 5 - SITE-SPECIFIC EVALUATION REPORT.....	5-1
SECTION 6 - REGULATORY NOTIFICATION.....	6-1
SECTION 7 - LUKE AFB SUPPORT REQUIREMENTS.....	7-1
SECTION 8 - PROJECT SCHEDULE.....	8-1
SECTION 9 - POINTS OF CONTACT.....	9-1
SECTION 10 - REFERENCES.....	10-1

TABLE OF CONTENTS (CONTINUED)

APPENDICES

- Appendix A - Quality Assurance Project Plan
- Appendix B - Luke AFB Addendum to The ICE Demonstration Program Health and Safety Plan
- Appendix C - Site SS-42 Analytical Data
- Appendix D - Supporting Regulatory Air Emissions Documentation
- Appendix E - Field Instrument Calibration Procedures

LIST OF TABLES

No.	Title	Page
2.1	Summary of Well Construction Details	2-3
2.2	Summary of Permeability Test Parameters	2-7
3.1	Manufacturer Performance Specifications for VR Systems Models V2C, V3, and V4	3-3
4.1	Proposed Sampling and Monitoring Schedule for SVE/ICE System.....	4-5

LIST OF FIGURES

No.	Title	Page
1.1	Site Location	1-2
2.1	Site Diagram	2-2
2.2	Soil TPH Concentrations	2-4
3.1	VR Systems V3 Schematic Diagram.....	3-2
4.1	Proposed SVE/ICE System Layout	4-1

SECTION 1

INTRODUCTION

This work plan describes a pilot-scale treatability demonstration to test the effectiveness of an internal combustion engine (ICE) to extract and treat nonchlorinated, fuel hydrocarbon volatile organic compounds (VOCs) at Site SS-42, at Luke Air Force Base (AFB), Arizona (Figure 1.1). Luke AFB is one of several Air Force installations identified as prospective test sites to demonstrate the ICE system with advanced emission controls as part of a low-cost soil vapor extraction (SVE) for sites contaminated with fuel VOCs. The ICE and emission control system to be tested is manufactured by VR Systems Inc. of Anaheim, California.

The proposed pilot test demonstration will be conducted in two phases. During the first phase, the VR Systems Model V3 ICE will be installed, and startup tests will be performed. The second phase will consist of ICE operation and monitoring for approximately 12 months. After completion of a 12-month treatability test, a site-specific evaluation report will be prepared summarizing the test results and presenting recommendations for a full-scale ICE system design.

This work plan is divided into 10 sections, including this introduction and four appendices. Section 2 discusses site background. Section 3 provides a process description of the vapor treatment technology. Section 4 describes the site-specific treatability test activities. Section 5 provides an example outline of the site-specific evaluation, and Section 6 identifies the regulatory notification requirements. Section 7 identifies plant support requirements. Section 8 provides the proposed test schedule, and Section 9 lists the key points of contact for Luke AFB, AFCEE, and Parsons ES. Section 10 provides the references cited in this document. Appendix A includes the Quality Assurance Project Plan (QAPP) for Luke AFB. Appendix B provides the Luke AFB addendum to the program health and safety plan for the ICE demonstration. Appendix C provides supporting analytical data for Site SS-42 (Geraghty & Miller, 1996). Appendix D includes documentation pertaining to project conformance with Maricopa County Division of Air Pollution Control air emissions requirements.

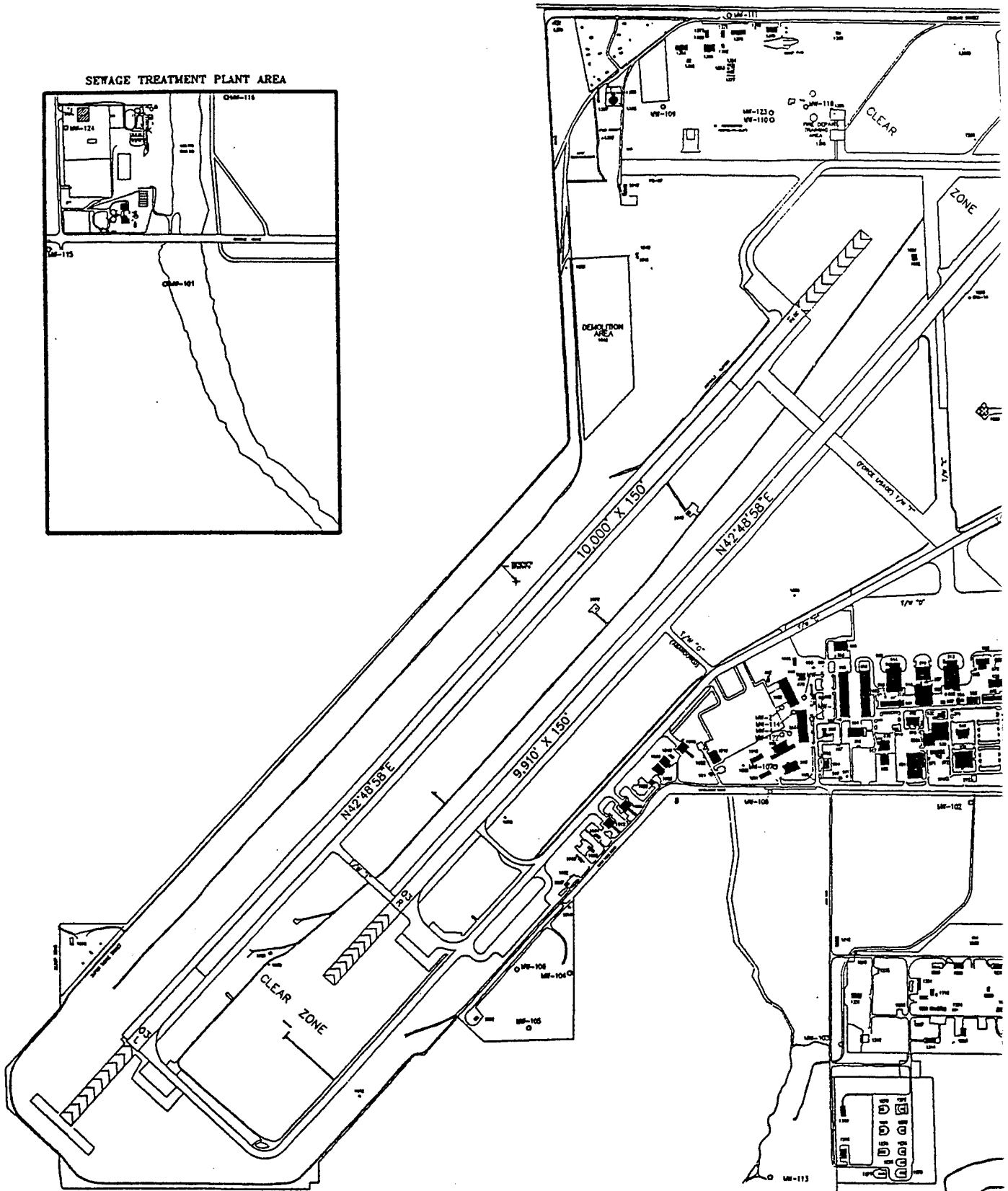
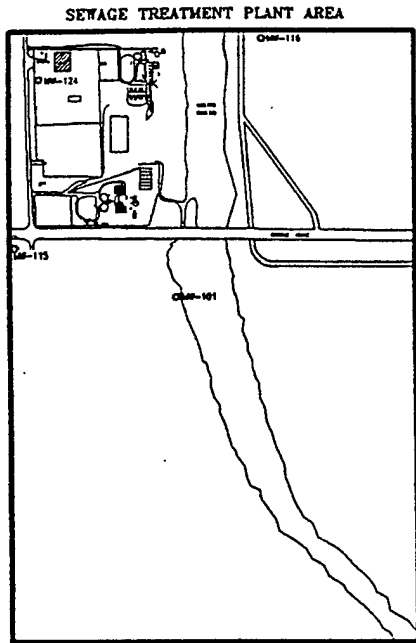

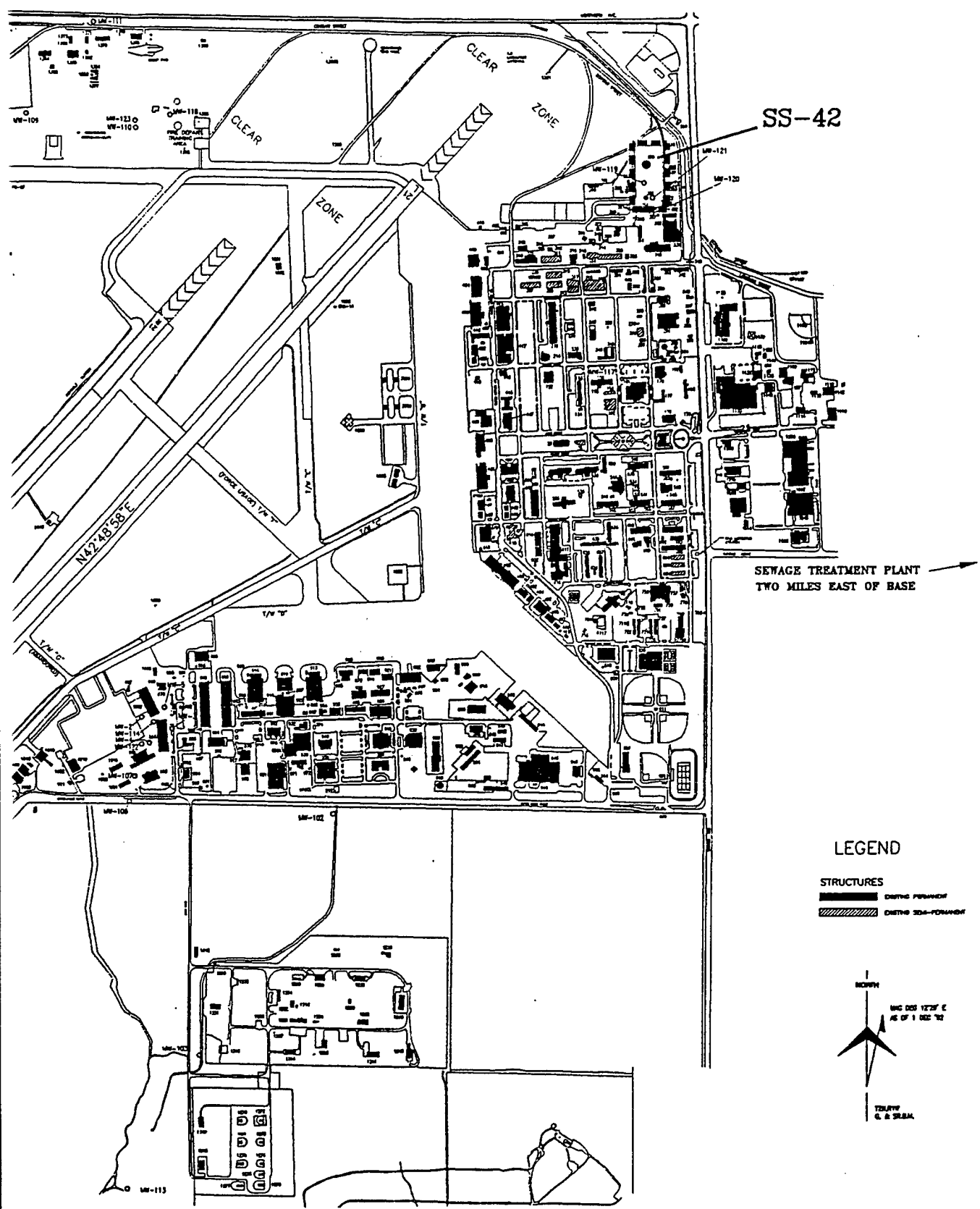

SS-42

SEWAGE TREATMENT PLANT
TWO MILES EAST OF BASE

LEGEND

- STRUCTURES
- ▬ DETHIC FORMANT
 - ▨ DETHIC 304-FORMANT

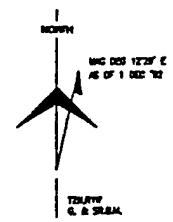

**PARSONS
ENGINEERING**

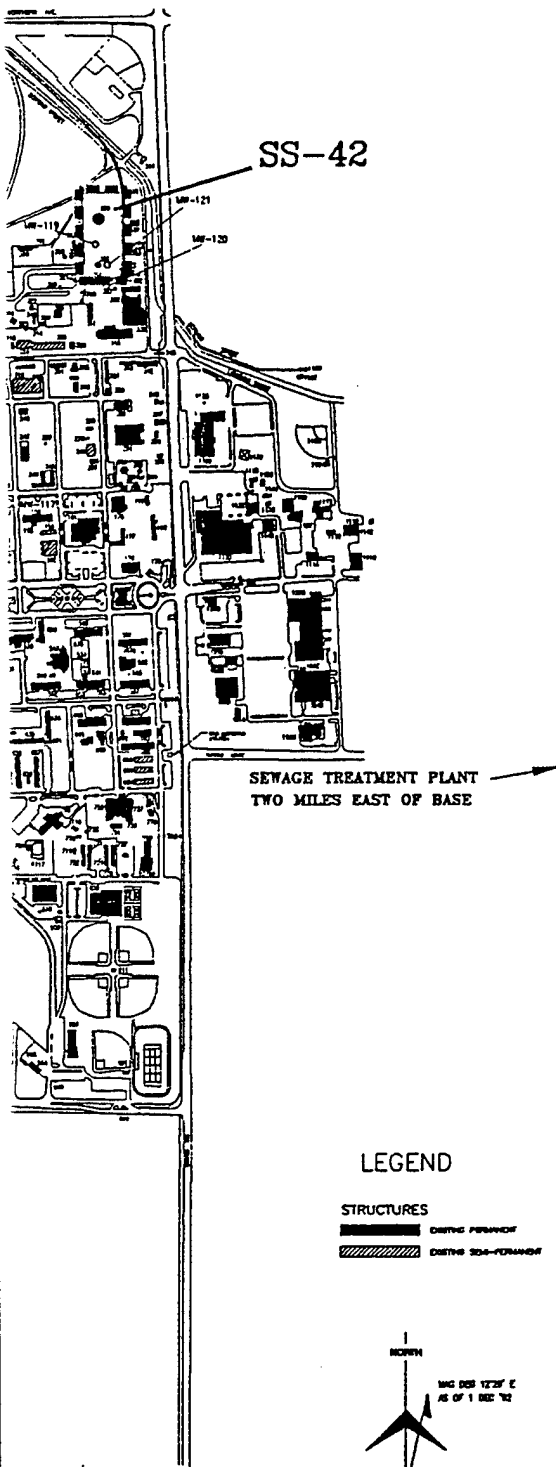

LEGEND

STRUCTURES

- EXISTING FOUNDATION
- EXISTING SOA-FOUNDATION

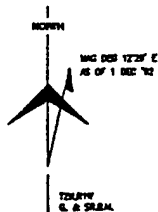

Approx. Scale

0 1400

SCALE: 1 inch = 1400 feet

FIGURE 1.1

SITE LOCATION

Site SS-42
ICE Demonstration
Luke Air Force Base, Arizona

**PARSONS
ENGINEERING SCIENCE, INC.**

SECTION 2

SITE DESCRIPTION

2.1 SITE HISTORY

2.1.1 Background

Site SS-42 is located at the bulk fuels storage yard in the eastern portion of Luke AFB (Figure 2.1). The site is a former oil/water separator and associated 1,000-gallon underground storage tank (UST) system that received condensate from two adjacent aboveground jet fuel storage tanks. The oil/water separator system and aboveground tanks (ASTs) were installed in 1954 (Geraghty & Miller, 1996).

Prior to 1960, aviation gas and JP-4 were delivered to the bulk fuels storage area by rail car and off-loaded through a hydrant system to the ASTs. From 1960 to 1993, the fuel delivery system consisted of a combination of aboveground and underground distribution pipelines. In 1992, a leak-detection system was installed for the oil/water separator system as a result of a detected fuel release. In September 1993, the oil/water separator and associated 1,000-gallon UST were removed (Geraghty & Miller, 1996).

2.1.2 Previous Investigations

In March 1993, Environmental Engineering Consultants, Inc. (EEC, 1993) drilled one initial borehole (UST-1) adjacent to the oil/water separator and six additional boreholes (UST-2 through -7) in the vicinity of the suspect UST (Figure 2.1). Following the initial EEC investigation in 1993, an additional 14 investigative soil borings (SB-1 through SB-14) were drilled and sampled by Geraghty & Miller (1996). Summaries of soil analytical data for benzene, ethylbenzene, toluene, and xylenes (BTEX) and total petroleum hydrocarbons (TPH) in soil at varying depth intervals are presented on Figures C.1 and C.2, in Appendix C. Geraghty & Miller (1996) also collected and analyzed 100 soil gas samples using a mobile laboratory in 1994, and installed 2 vapor monitoring wells (VM-1 and VM-2) and 4 groundwater monitoring wells (MW-119, MW-120, MW-121, MW-125).

In May 1995, three air injection venting wells (IW-1, -2, and -3) and four multi-depth vapor monitoring points (MP-1, -2, -3, and BW-1) were installed and sampled near the former oil/water separator as part of a bioventing treatability study (Geraghty & Miller, 1996). Groundwater samples also were collected during this investigation. A summary of vent well construction details is presented in Table 2.1. A summary of soil TPH concentrations measured in the well boreholes at 30, 70, and 140 feet below ground surface (bgs) is presented on Figure 2.2.

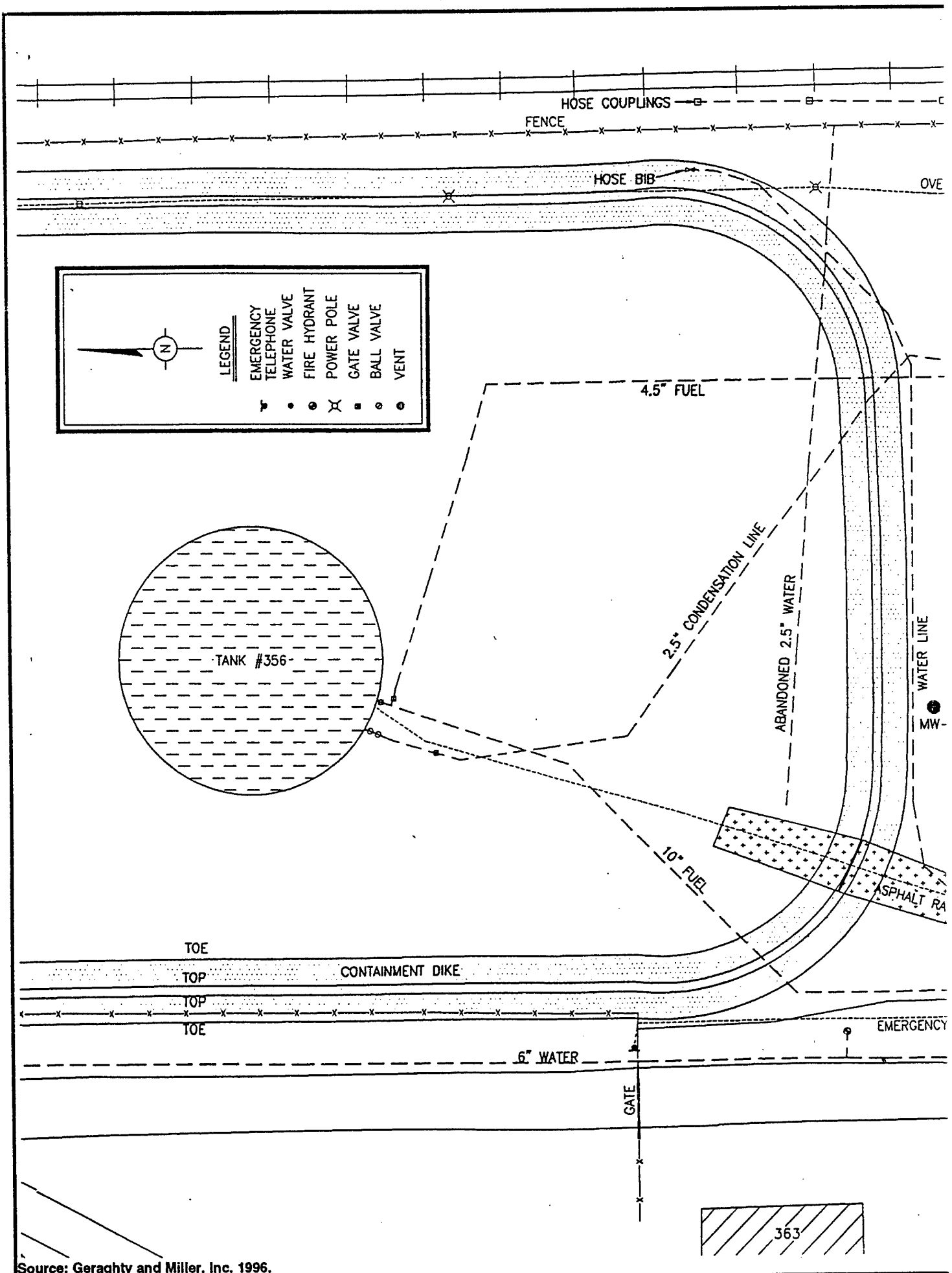

Source: Geraghty and Miller, Inc. 1996.

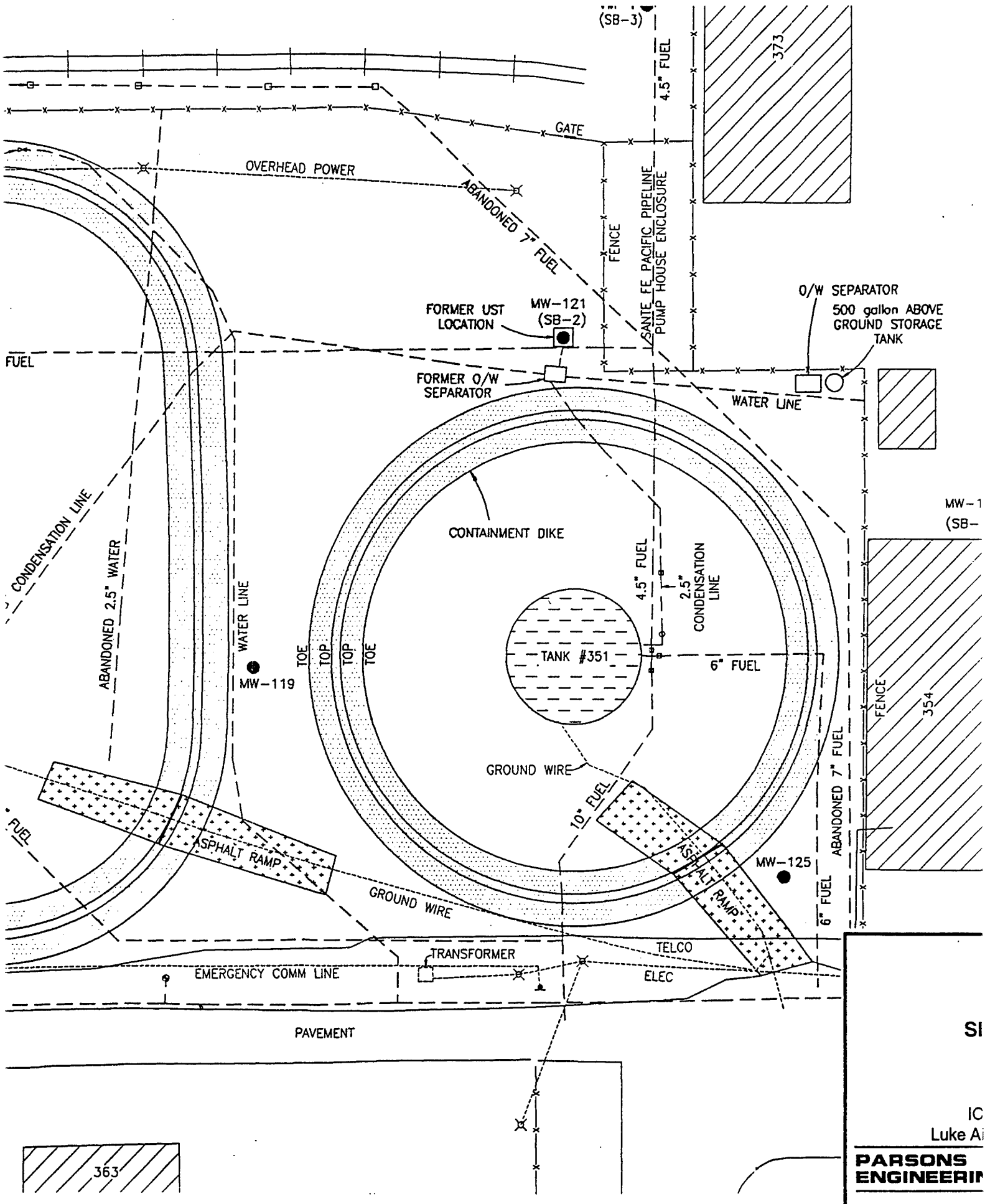

SI
 IC
 Luke Ai
PARSONS ENGINEERING

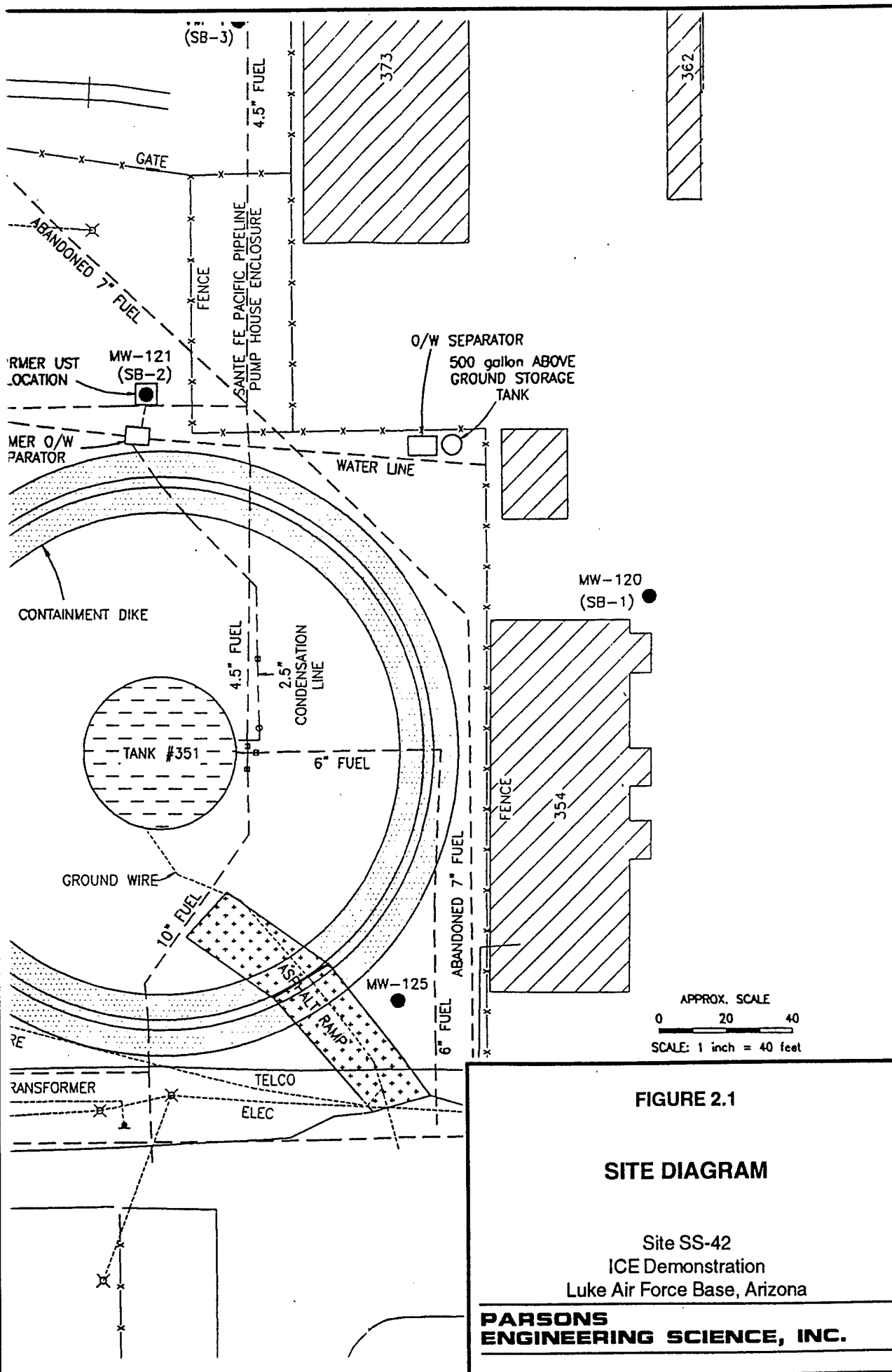

FIGURE 2.1

SITE DIAGRAM

Site SS-42
 ICE Demonstration
 Luke Air Force Base, Arizona

**PARSONS
 ENGINEERING SCIENCE, INC.**

TABLE 2.1
SUMMARY OF WELL CONSTRUCTION DETAILS
SITE SS-42
ICE DEMONSTRATION
LUKE AIR FORCE BASE, AIRZONA

Well/ Monitor Point	Diameter (inches)	Total Boring Depth (feet bgs)	Screened Interval (feet bgs)
IW-1	4	80.5	30-80
IW-2	4	140.5	90-140
IW-3	4	202	150-200
MP-1-75	1	200	73-74
MP-1-131	1	200	129-130
MP-1-161	1	200	158-159
MP-2-71	1	200	70-71
MP-2-141	1	200	140-141
MP-2-186	1	200	185-186
MP-3-71	1	200	70-71
MP-3-136	1	200	135-136
MP-3-161	1	200	160-161
BW-1-70	1	200	70-71
BW-1-140	1	200	140-141
BW-1-185	1	200	185-186
VM-1	2	311	140-200
VM-2	2	311	65-135

Source: Geraghty & Miller, 1996.

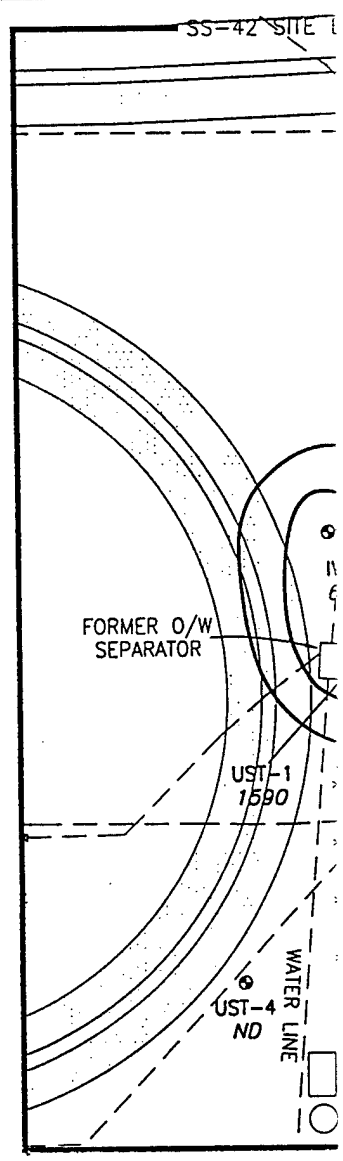
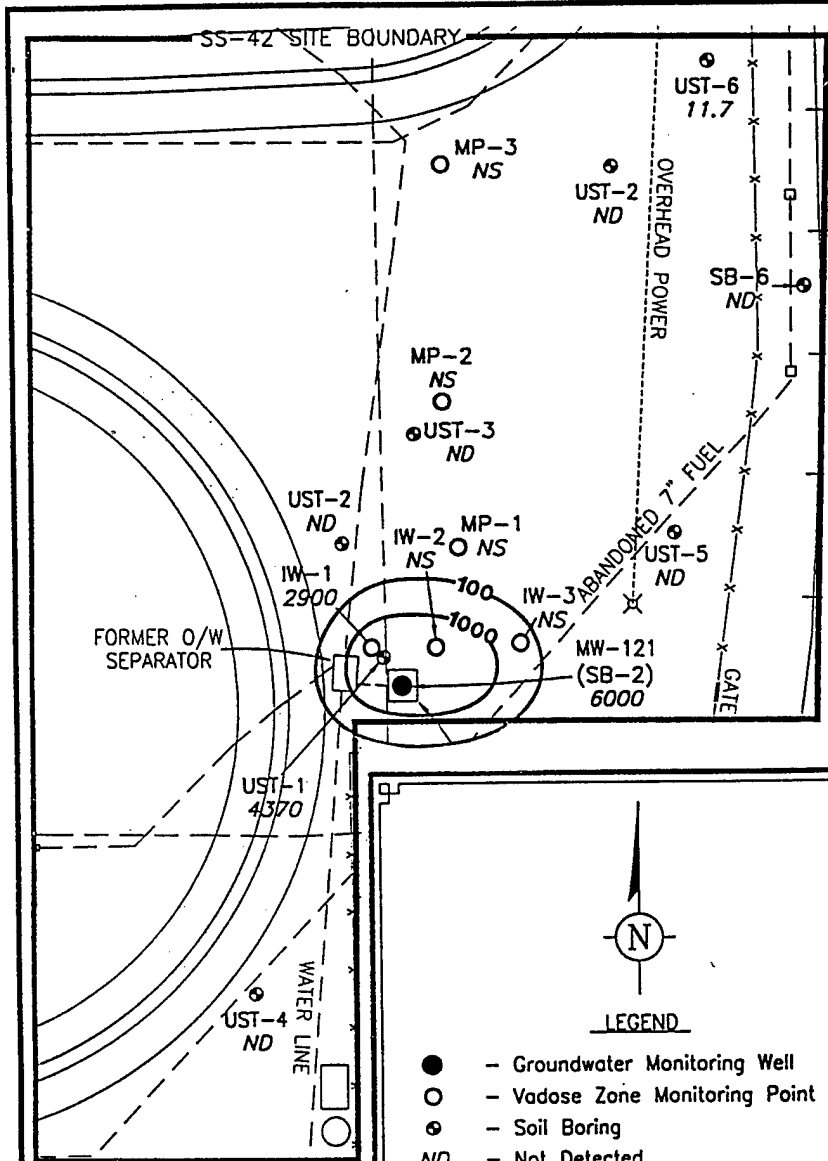

N

LEGEND

- - Groundwater Monitoring Well
- - Vadose Zone Monitoring Point
- ⊙ - Soil Boring
- ND - Not Detected
- NS - No Sample Collected
- 2900 - TPH Concentration (mg/kg)
- 100 - TPH Concentrations Contour (mg/kg)

Note: TPH Data are from samples collected over the period from March 1993 through May 1995.

**TPH CONCENTRATIONS IN SOIL
30 FEET BELOW GROUND SURFACE**

**TPH C
70 FEET**

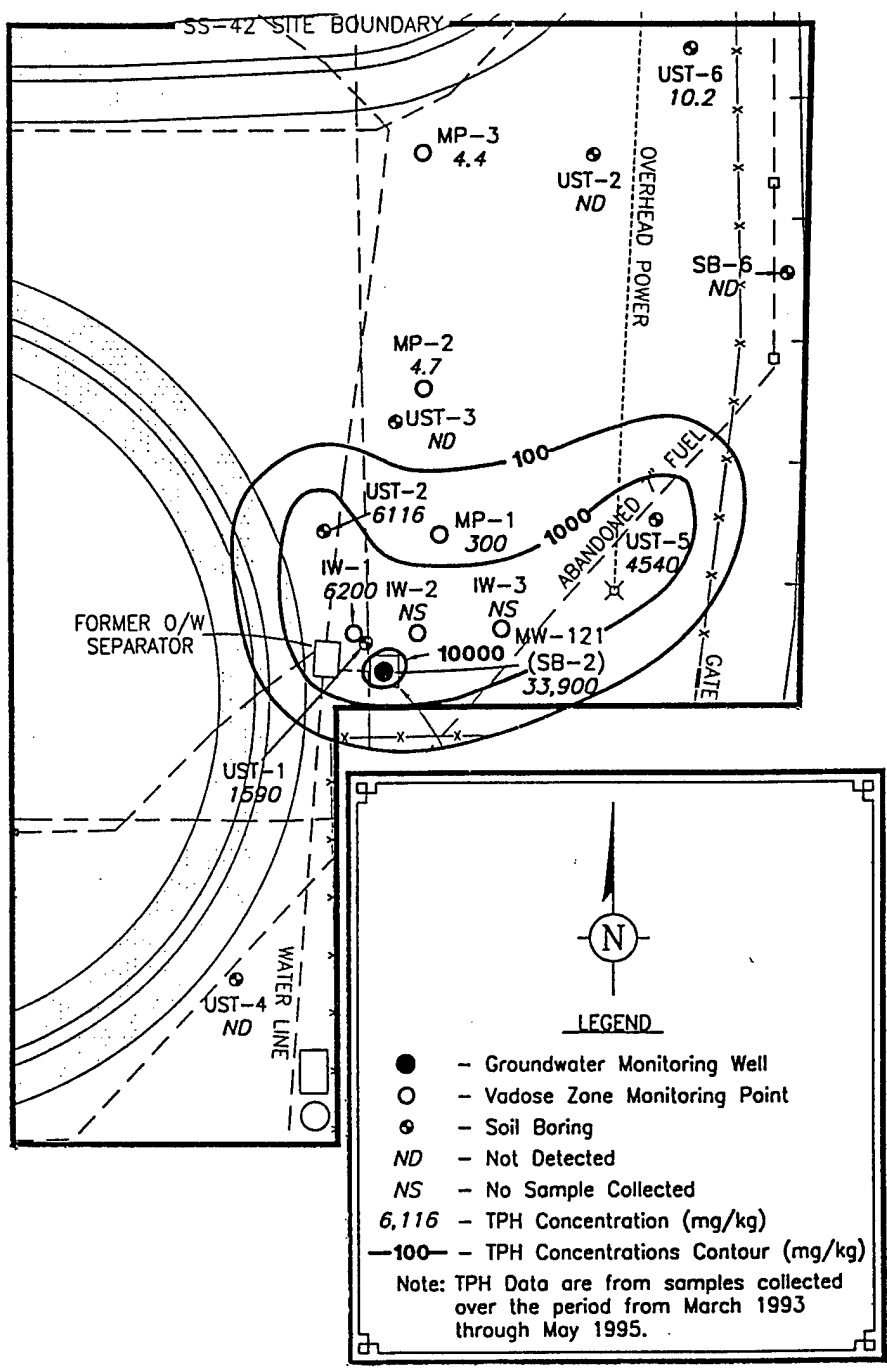

TPH CONCENTRATIONS IN SOIL
70 FEET BELOW GROUND SURFACE

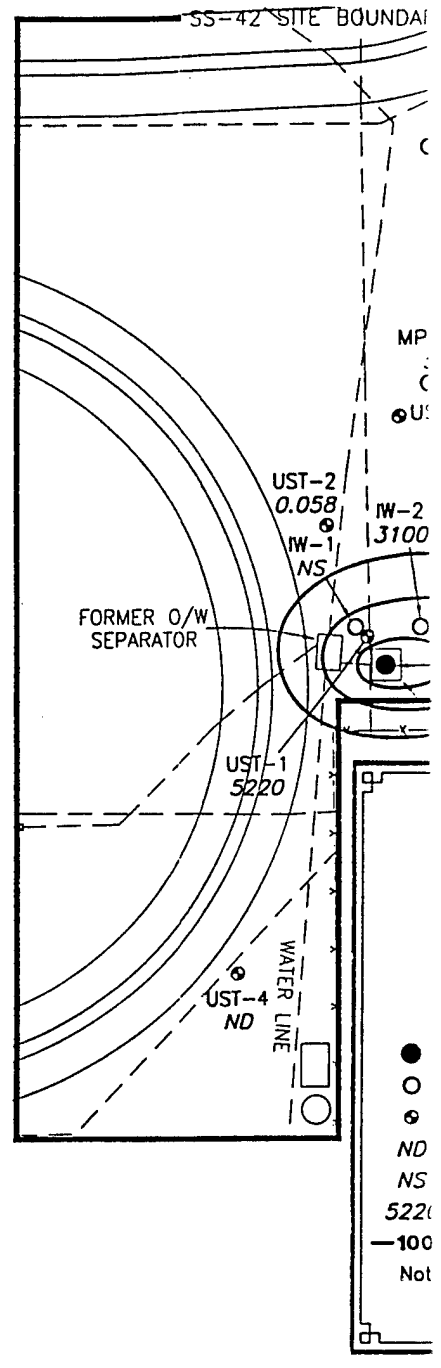

TPH CONCENTRATIONS IN SOIL
140 FEET BELOW GROUND SURFACE

PARSC
ENGINEERS

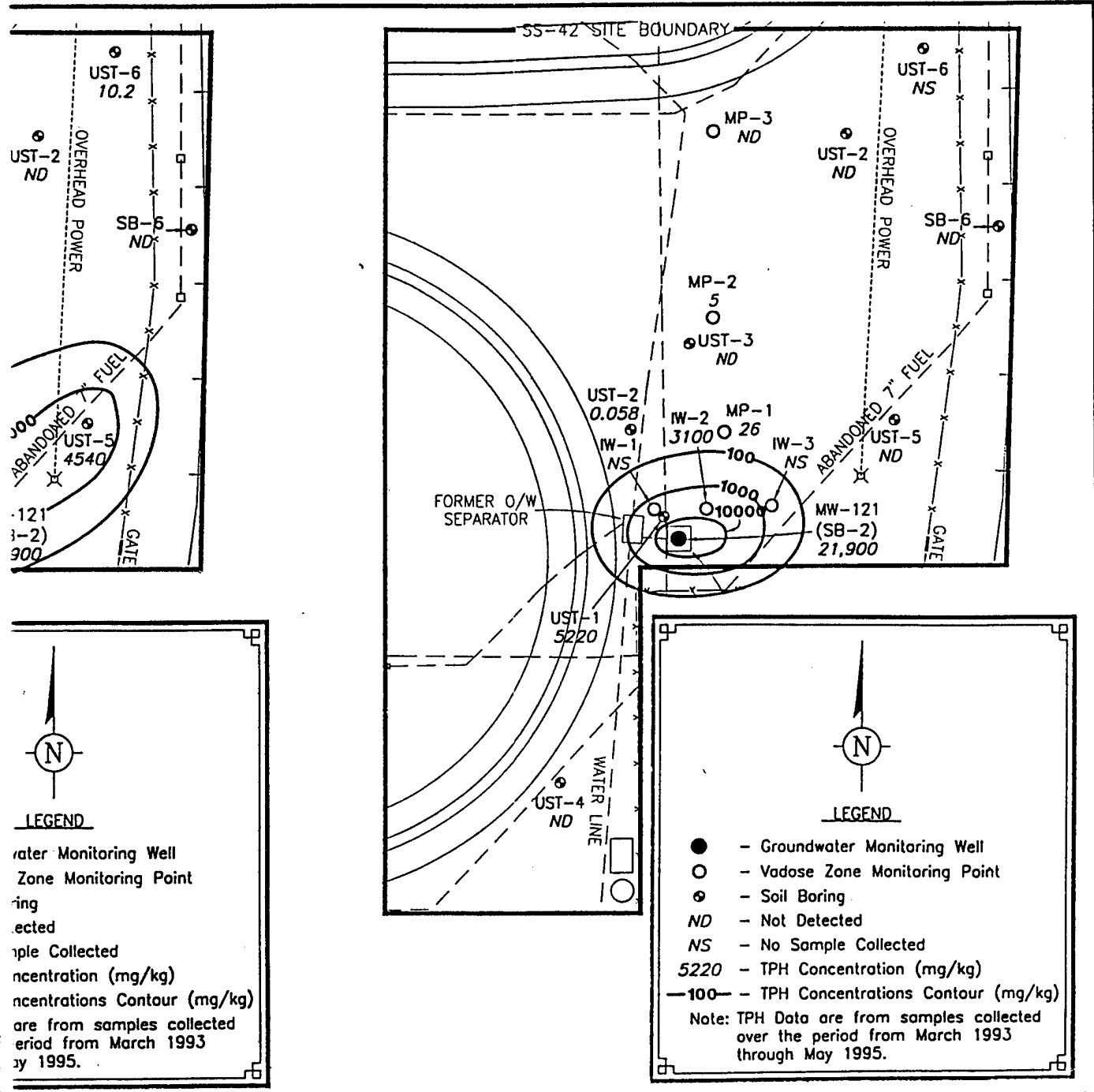

IN SOIL
SURFACE

**TPH CONCENTRATIONS IN SOIL
140 FEET BELOW GROUND SURFACE**

FIGURE 2.2

**SOIL TPH
CONCENTRATIONS**

Site SS-42
ICE Demonstration
Luke Air Force Base, Arizona

**PARSONS
ENGINEERING SCIENCE, INC.**

2.2 SITE GEOLOGY AND HYDROGEOLOGY

Surficial soils underlying SS-42 consist of unconsolidated fill material up to 10 feet bgs. Underlying the surficial fill is Quaternary alluvium consisting of interbedded sand, silt, and clay deposits. Below 100 feet bgs the well-graded sand units are no longer in sequence, and primarily interbedded sandy clays are the dominant sediment type to a maximum sampled depth of 200 feet bgs. Thin lenses of sandy gravel and gravely sand occur throughout the interval (Geraghty & Miller, 1996).

Currently, the top of the groundwater table occurs beneath the site at a depth of approximately 320 feet bgs, and the flow direction is south with a gradient of approximately 0.003 foot per foot (ft/ft). Groundwater levels have declined over the past 50 years due to groundwater withdrawal associated with intensive agricultural activities (Geraghty & Miller, 1996). The groundwater level in the 1950s was estimated to occur at approximately 70 feet bgs.

2.3 NATURE AND EXTENT OF CONTAMINATION

2.3.1 Groundwater Quality

Groundwater sampling data indicate that the groundwater beneath the site has apparently not been impacted from the release of petroleum hydrocarbons. TPH and target semivolatile organic compounds have not been detected in any of the groundwater samples collected at the site (Geraghty & Miller, 1996).

2.3.2 Soil Quality

Soil analytical data were collected during the installation of the bioventing test system wells. TPH results from the injection well sampling ranged from 4.3 milligrams per kilogram (mg/kg) in a sample from 150 feet bgs at IW-3 to a maximum of 12,000 mg/kg in a sample from 70 bgs in borehole IW-1. The maximum detected soil BTEX concentration was 414 mg/kg in a soil sample from 70 feet bgs in borehole IW-1. A sample from IW-3 at 200 feet bgs had a TPH concentration of 5.2 mg/kg, and no BTEX were detected.

Soil samples also were collected at 70, 140, and 200 feet bgs in each of the four vapor monitoring wells. Additional samples were collected at 160 and 180 feet bgs in vapor monitoring point boreholes MP-3 and MP-2, respectively. A TPH concentration of 4.4 mg/kg at 70 feet bgs was the only hydrocarbon detection in BW-1 and MP-3. In borehole MP-1, 330 mg/kg TPH was detected at 70 feet bgs, and total BTEX concentrations ranged from 19,320 micrograms per kilogram ($\mu\text{g}/\text{kg}$) in the soil sample from 70 feet bgs to nondetect in the sample from 200 feet bgs. Geraghty & Miller (1996) soil BTEX and TPH results are summarized in Appendix C.

2.3.3 Soil Gas

Field and laboratory analyses collected by Geraghty & Miller (1996) during a 4-hour SVE test at each IW location showed that the extracted vapors from the extraction wells contained high concentrations of total organic compounds. The total non-methane fuel concentrations ranged from 42,000 to 200,000 milligrams per cubic meter (mg/m^3), or

approximately 12,000 to 57,000 parts per million, volume per volume (ppmv) (Table 2.2). Using data from the SVE test (total fuel vapor concentration of 130,000 mg/m³ and a flow rate of 171 cubic feet per minute [cfm]), the calculated mass removal rate would be approximately 2,000 pounds of hydrocarbons per day.

TABLE 2.2
SUMMARY OF PERMEABILITY TEST PARAMETERS
SITE SS-42
ICE DEMONSTRATION
LUKE AIR FORCE BASE, ARIZONA

Parameter	Measurement		Extraction Test			
	Method	Units	IW-1	IW-2	IW-3	Combined
Field Measurements						
Flow Rate	Pitot Tube	cfm ^{a/}	122	153	116	171
Applied Vacuum	Magnehelic Gauge	H ₂ O ^{b/}	99	83	108	50
Total Organics	Gas Tech PID ^{c/}	ppmv ^{d/}	>9,999	7,600	>9,999	>9,999
Total Organics	OVA/FID ^{e/}	ppmv	>1,000	>1,000	>1,000	>1,000
Laboratory Measurements						
Total Volatile Fuels	USEPA TO-14	mg/m ^{3 f/}	70,000	200,000	42,000	130,000
Total Volatile Fuels	USEPA TO-14	ppmv	20,000	57,000	12,000	37,000
Benzene	USEPA TO-14	mg/m ³	1,400	9,600	610	4,900
Toluene	USEPA TO-14	mg/m ³	1,700	4,200	30	2,400
Ethylbenzene	USEPA TO-14	mg/m ³	990	380	25	240
Xylenes	USEPA TO-14	mg/m ³	1,200	1,000	59	800

Source: Geraghty & Miller, 1996.

^{a/} cfm = cubic feet per minute.

^{b/} H₂O = inches of water.

^{c/} PID = photoionization detector.

^{d/} ppmv = parts per million, volume per volume.

^{e/} OVA/FID = organic vapor analyzer/flame ionization detector.

^{f/} Milligrams per cubic meter.

SECTION 3

INTERNAL COMBUSTION ENGINE TREATMENT TECHNOLOGY

The primary off-gas treatment technology proposed for this demonstration consists of combustion in an ICE with advanced emission controls. The ICE technology is discussed in the following sections.

3.1 VAPOR EXTRACTION AND COMBUSTION

3.1.1 System Description

SVE with VOC combustion is an innovative technology that uses a gasoline-burning ICE with advanced emission controls to extract and burn hydrocarbon vapors from contaminated vadose zone soils. Vapors are extracted from SVE wells screened in the contaminated soils using the intake manifold vacuum of the engine. The vapors are then burned as fuel to run the engine. The exhaust gases pass through standard catalytic converters for complete oxidation before being discharged into the atmosphere.

VR Systems, Inc. of Anaheim, California has developed a Model V3 ICE unit that uses a Ford Motor Company® 460-cubic-inch-displacement engine block, heads, and accessories along with an onboard computer system that monitors engine performance. The intake manifold of the engine provides the vacuum source, up to 18 inches of mercury or approximately 245 inches of water. Flow rates range from 0 to 250 standard cubic feet per minute (scfm), depending on soil conditions and the hydrocarbon concentrations of the extracted soil gas. VR Systems, Inc. manufactures vapor recovery systems in three sizes. A system schematic of the V3 (proposed for this pilot test) unit is provided in Figure 3.1. The performance specifications of the VR Systems units including the V3 model are provided in Table 3.1.

The VR Systems Model V3 unit is designed to remove nonchlorinated hydrocarbon vapors from contaminated soil using a vapor extraction vent well like those installed at Site SS-42. The extracted vapors flow through a computer-monitored fuel control system, and into the intake manifold of the engine. Destruction of the majority of hydrocarbon vapors occurs through combustion in the engine. Exhaust gases from the engine pass through a small catalytic converter that completes the treatment process. Treated vapors are then discharged into the atmosphere.

An on-board computer system provides the necessary monitoring for maximum engine efficiency. The data acquisition system includes a 16-channel data reporting system that monitors the engine's oil pressure/temperature, coolant temperature,

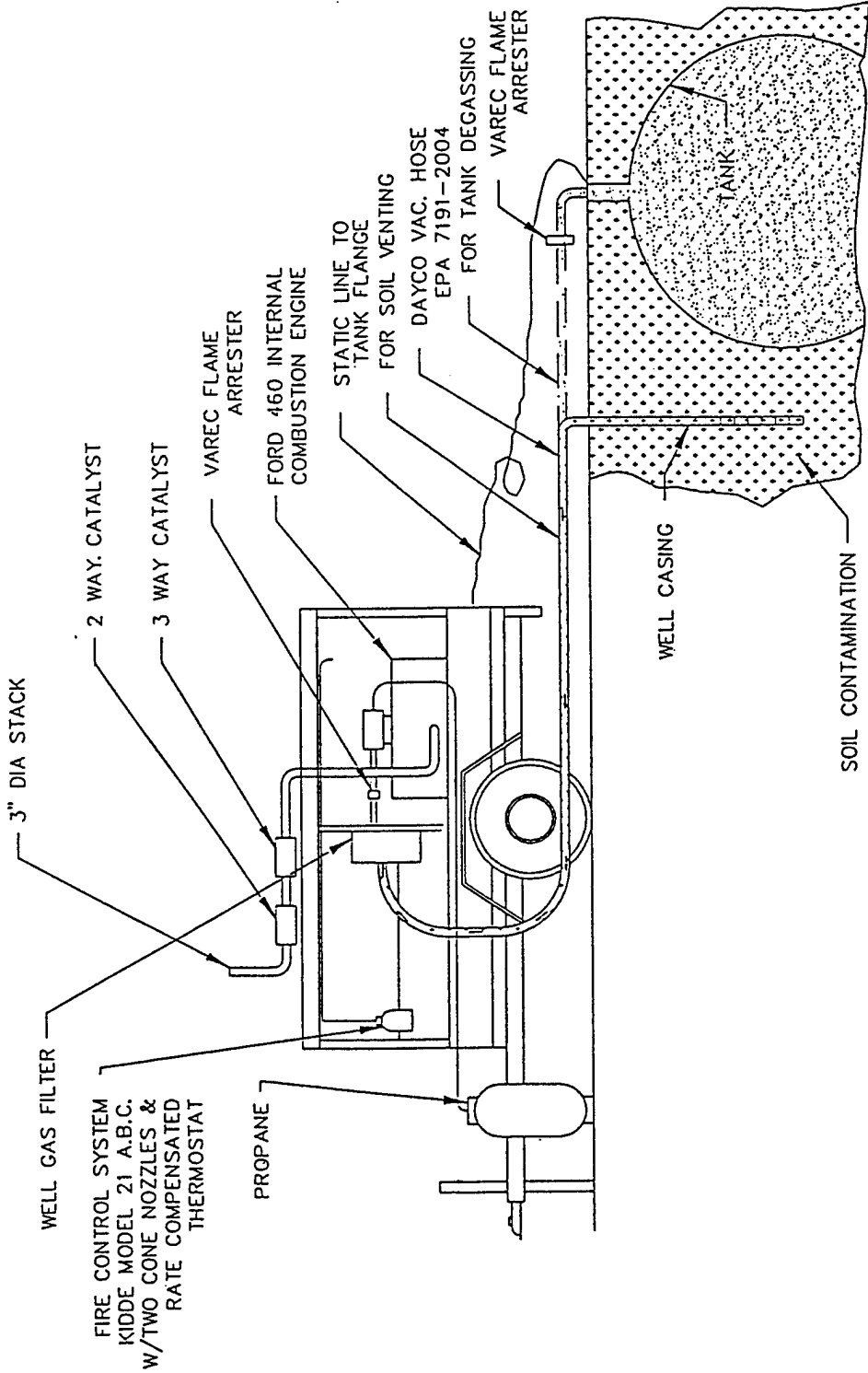

FIGURE 3.1

**VR SYSTEMS
SCHEMATIC DIAGRAM
MODEL VR3**

Site SS-42
ICE Demonstration
Luke Air Force Base, Arizona

**PARSONS
ENGINEERING SCIENCE, INC.**
Denver, Colorado

NOT TO SCALE

TABLE 3.1
MANUFACTURER PERFORMANCE SPECIFICATIONS
FOR VR SYSTEMS MODELS V2C, V3, AND V4
SITE SS-42
ICE DEMONSTRATION
LUKE AIR FORCE BASE, ARIZONA

Feature	V2C	V3	V4
Max. Hydrocarbon Destruction Rate	15 lbs/hr	55 lbs/hr	110 lbs/hr
Destruction Efficiency for TVH/BTEX ^{a/}	> 99%	> 99%	> 99%
Engine Size in Cubic Inch Displacement	140	460	920 (2 x 460)
Max. Flow Rate in Cubic Feet/Min	65	250	500
Max. Vacuum in Inches of Mercury/Approx. Inches of Water	18/245	18/245	18/245
Required Soil Gas Hydrocarbon concentration (ppmv as gasoline) ^{b/}	40,000	40,000	40,000

^{a/} TVH = total volatile hydrocarbons; BTEX = benzene, toluene, ethylbenzene, and xylenes.

^{b/} The influent vapor concentration in ppmv = parts per million, volume per volume required to sustain >99% destruction efficiency without the addition of supplemental fuel (propane or natural gas).

exhaust temperature, exhaust percent oxygen, engine speed, and operation (flow rates, inches of vacuum pressure, supplemental fuel consumption, air/fuel ratio, and engine hours). The V3 unit also is equipped with an automatic engine shutdown system. Monitored by the on-board computer, the engine shuts down automatically if one or more of the following conditions exists: engine overspeed, high coolant temperature, high oil temperature, low oil pressure, fire, or high water level in the SVE well gas filter assembly. The computer is programmed to store and report the reason for the automatic engine shutdown.

Supplemental fuel (propane or natural gas) is used to provide smooth operation of the engine as extracted soil gas vapor concentrations fluctuate. Supplemental fuel use can be eliminated if the extracted soil gas vapor concentrations provide sufficient fuel to sustain combustion and smooth operation of the engine. Soil vapor hydrocarbon concentrations in excess of 40,000 ppmv are generally sufficient to sustain the engine without the need for supplemental fuel. The computer regulates the fuel requirements of the engine through a master control unit (MCU). The MCU makes adjustments in the supplemental fuel flow to compensate for the changing influent hydrocarbon concentrations and to maintain the stoichiometric air-to-fuel ratio. By maintaining the proper air/fuel ratio, the total hydrocarbon vapor destruction efficiency typically exceeds 99 percent.

The V3 unit also is equipped with a flame arrestor to protect the vapor extraction system from "flash back" from the engine. A fire control system equipped with a dry chemical extinguisher is provided to discharge automatically in case of a fire.

External electrical power is not required. The electronic ignition system is battery powered and adjusts automatically in response to commands from the computer. The Model V3 unit also is equipped with a modem for remote monitoring and to make necessary adjustments to vacuum or engine speed to optimize engine performance and minimize supplemental fuel consumption. The remote monitoring capability also allows for adjustments to be made while the unit is operating.

3.1.2 Regulatory Acceptance

The acceptance of this technology has been widespread. VR Systems, Inc. units have been approved for air treatment in Arizona, California, and 26 other states. Appendix D provides documentation from the Maricopa County Division of Air Pollution Control that provides approval for the proposed ICE demonstration at Site SS-42.

SECTION 4

PILOT TEST ACTIVITIES

The purpose of this section is to describe the work that will be performed by Parsons ES at Site SS-42 during the ICE demonstration. Brief descriptions of the layout of the pilot test components and test procedures are provided in the following sections. A complete ICE system components check will be performed during the initial startup and optimization period to ensure proper system operation prior to the performance evaluation period. Additionally, several influent and effluent soil vapor samples will be collected during the startup and optimization period to evaluate the system performance during non-steady-state conditions. Most of these samples will be analyzed in the field for the total organic vapor (TOV) content using a hand-held, direct-reading instrument. Several confirmatory samples will be shipped to an air analytical laboratory for VOC analysis using US Environmental Protection Agency (EPA) Method TO-3 for BTEX and total volatile hydrocarbons. (TPH).

A thorough cost and performance evaluation of the system will be conducted during the performance evaluation period. This evaluation will examine the TVH/BTEX destruction efficiency of the extracted soil gas, operating costs, impacts on efficiency and costs under varying influent vapor concentrations and flow rates, overall system reliability, and other useful operating parameters as determined by the field scientist.

Variations in these operating parameters will be evaluated to determine the applicability of the ICE system for use in a full-scale SVE and treatment system design. A description of the system layout, pilot test components, and test procedures is provided below.

4.1 PILOT TEST DESIGN

4.1.1 Layout of Pilot Test Components

Existing injection/extraction vent wells (IWs), vapor monitoring points (MPs), and associated vapor line manifold piping for the previously installed bioventing system will be used for this treatability test. No additional IWs or MPs are proposed for this test. Figure 4.1 illustrates the locations of the existing IWs, MPs, piping, electrical service, and proposed location of the ICE unit. The ICE unit will be connected to a main pipe header using 2-inch flexible hose and will be located near the northwest corner of Building 353. A valve will be attached at each IW in order to maintain independent flow control during the demonstration period.

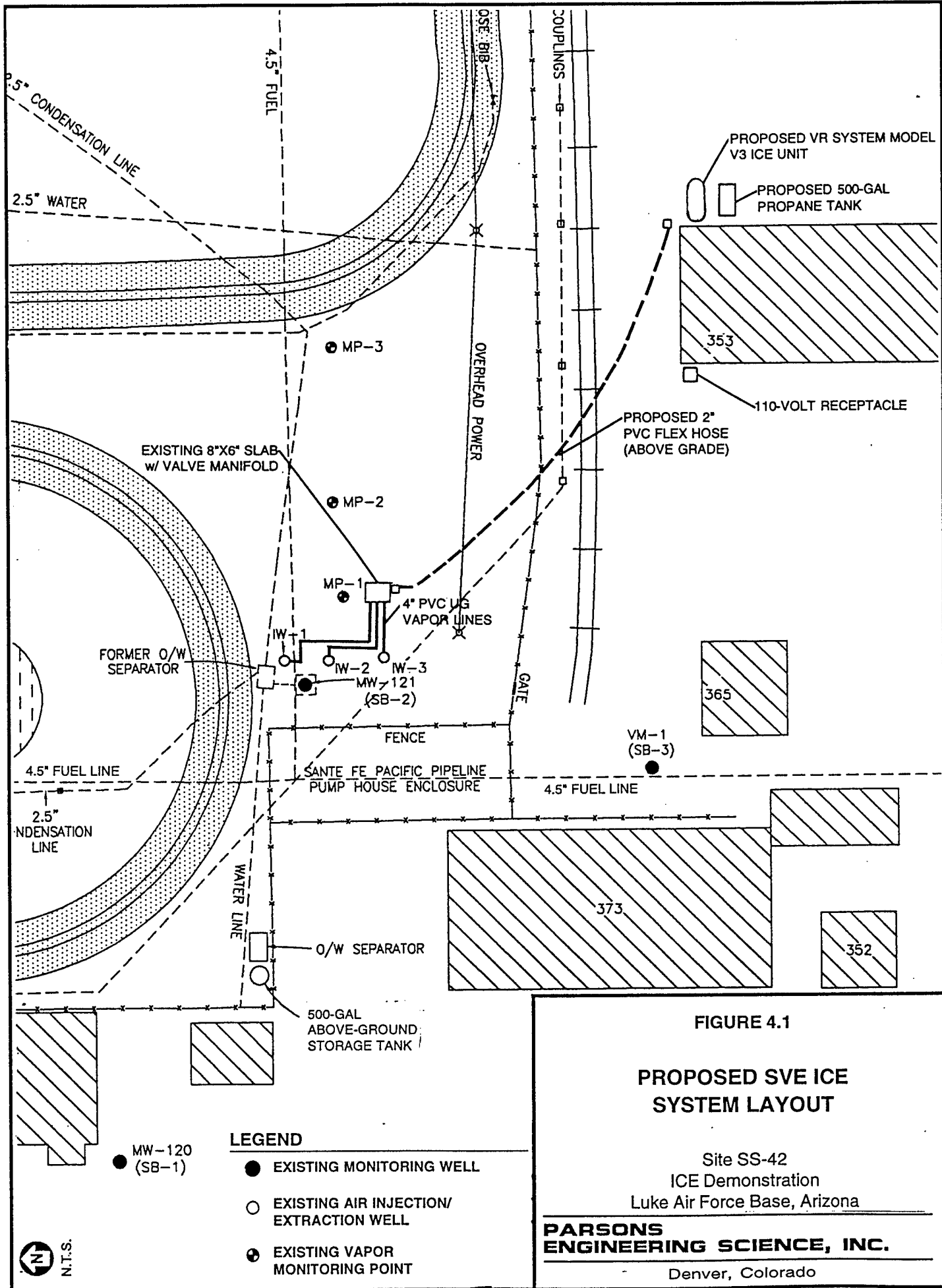

FIGURE 4.1

PROPOSED SVE ICE SYSTEM LAYOUT

Site SS-42
ICE Demonstration
Luke Air Force Base, Arizona

PARSONS ENGINEERING SCIENCE, INC.

Denver, Colorado

LEGEND

- MW-120 (SB-1)
- EXISTING MONITORING WELL
- EXISTING AIR INJECTION/EXTRACTION WELL
- ⊙ EXISTING VAPOR MONITORING POINT

A 500-gallon ICE supplemental fuel (propane) storage tank will be located at least 15 feet from the ICE unit. This tank will be clearly labeled to indicate its contents. The ICE system will be clearly labeled with a contractor's nameplate that will include the following information as a minimum:

- Contractor - Parsons ES;
- Internal Combustion Engine System;
- Telephone Numbers; and
- Emergency Points of Contact.

4.1.1.1 Extraction Wells

The bioventing injection/extraction wells IW-1, IW-2, and IW-3 will be used as vapor extraction wells for the ICE demonstration (Figure 4.1). The existing piping manifold for the wells will be connected to the ICE unit by aboveground, 2-inch flexible hose.

4.1.1.2 Monitoring Points

Existing vapor (vacuum) monitoring points MP-1, MP-2, MP-3, and BW-3, installed for the bioventing treatability study (Geraghty & Miller, 1996), will be used during the SVE/ICE demonstration to determine radius of vacuum influence and changes in soil gas chemistry at the site.

4.1.1.3 Piping System

All existing piping from the individual IWs to a centrally located manifold system is constructed of 4-inch-diameter polyvinyl chloride (PVC). The proposed vapor line tie-in for the SVE system demonstration will be at the manifolded section of the bioventing system. Approximately 150 feet of above-grade 2-inch PVC flexible hose will connect the ICE unit to the bioventing/extraction well manifold. This tie-in will allow direct access to all extraction wells without modifying the existing bioventing system. The vapor line tie-in for the SVE system demonstration will be labeled "vapor line."

4.2 ICE SYSTEM TESTING

4.2.1 Phase 1 - Startup and System Optimization

Following installation of the VR Systems Model V3 ICE unit at Site SS-42, a 5-day startup test will be performed to ensure that the ICE vapor treatment system is operating properly. Initial soil gas samples will be collected before system startup from the MPs and field screened for oxygen and carbon dioxide using direct-reading instruments. Prior to sample collection, the field instruments will be calibrated according to the procedures outlined in Appendix E. These baseline results will be compared to subsequent sampling results to determine the reductions in TVH during system operation. TVH will be measured in extracted soil gas samples collected before and after the ICE to determine TVH destruction efficiency. Additionally, initial

influent and effluent air samples will be collected in 1-liter SUMMA® canisters and submitted to an analytical laboratory for BTEX and TVH analyses using EPA Method TO-3.

During this 5-day phase 1 period, air flow rates and other system parameters will be adjusted to optimize vapor extraction rates and treatment efficiency. TVH and BTEX results will be used to determine initial fuel removal rates, air treatment efficiency, and compliance with air quality regulations. The proposed operation and monitoring schedule for the VR System™ ICE is presented in Table 4.1.

The radius of vacuum influence will be determined for each IW. To determine the radius of influence, pressure response and changes in soil gas oxygen, carbon dioxide, and TVH concentrations will be monitored at the MPs. The schedule provided in Table 4.1 is for planning purposes, and may be modified based on actual field conditions encountered during the startup tests.

4.2.2 Phase 2 - Extended Operation and Performance Evaluation

Following startup and optimization of the ICE system, the extended performance of the vapor-phase treatment unit and the cost of standard operation will be evaluated during the remainder of the 12-month test period. During the remainder of the Phase 2 test period, monthly sampling events will be conducted by Parsons ES. During each sampling event, one influent and one effluent sample will be collected for laboratory analysis. In addition, two duplicate samples will be collected during the 12-month test period, for a total of 26 Phase 2 vapor samples (exclusive of the Phase 1 startup samples). The samples will be analyzed using EPA Method TO-3.

During the performance test period, several conditions will be monitored. These conditions/parameters will include:

- Varying flow rates and influent TVH concentrations to determine maximum performance;
- Destruction efficiencies under varying test conditions;
- Operating costs (e.g., use of supplemental fuel); and
- Long-term reliability.

TABLE 4.1
PROPOSED SAMPLING AND MONITORING SCHEDULE
FOR SVE/ICE SYSTEM
SITE ST-12
ICE DEMONSTRATION
LUKE AIR FORCE BASE, ARIZONA

Elapsed time, Frequency	Laboratory Samples		Field Measurements				
	Influent Soil Gas (Before Treatment) BTEX, TVH	Effluent Soil Gas (Exhaust) BTEX, TVH	Soil Gas ^{a/} O ₂ /CO ₂ /TVH	ICE System ^{b/}	Exhaust TVH	System Flow Rates and Pressures	MP/IW Vacuum Response
Startup Testing							
0 Hours			X				X
1 Hour			X	X	X	X	X
Hourly; first 8 hours			X	X	X	X	X
Confirmatory Samples ^{c/}	X	X					
Extended Testing							
Daily; first week			X	X	X	X	X
Weekly during first week	X	X					
Monthly	X	X	X	X	X	X	X

^{a/} Soil gas oxygen (O₂), carbon dioxide (CO₂), and total volatile hydrocarbons (TVH) will be measured in both the extracted soil gas and in samples collected from monitoring points.

^{b/} Measurements will include: engine coolant, oil and exhaust temperature, oil pressure, intake vacuum (inches of water), flow rate (scfm), carburetor and well valve positioning, supplemental fuel usage, duty cycle (efficiency), and engine hours.

^{c/} Laboratory samples collected during the startup/optimization period will be determined in the field based on site conditions and system performance, including up to four separate sampling events.

4.2.3 System Monitoring

The SVE system will be monitored following the schedule presented in Table 4.1. System monitoring will follow this schedule unless an unanticipated circumstance occurs during the demonstration that prevents proper operation of the test equipment. In such an event, the monitoring schedule will be resumed once proper system operation is restored.

Required routine system maintenance (monthly service), and daily system monitoring (remote call up via cellular phone) will be conducted by VR Systems, Inc. personnel. Any additional maintenance (e.g., system optimization), if required, will be performed by Parsons ES personnel during the scheduled sampling events.

4.3 DEMOBILIZATION

After completion of the ICE vapor-phase treatment demonstration at Site SS-42, Luke AFB, Parsons ES will decontaminate the equipment (as appropriate), disconnect the piping, and prepare the ICE unit for shipment, unless otherwise directed by the Air Force.

SECTION 5

SITE-SPECIFIC EVALUATION REPORT

A site-specific technical report will be prepared for the ICE system demonstration at Site SS-42 after the 12-month test is complete. The report will present the system operating and monitoring data, analytical results obtained during testing, interpretation of these data, reductions achieved in target contaminant concentrations with respect to vapor flow rates and initial concentrations, a cost/performance data analysis comparing the VR Systems Model V3 ICE unit operations to traditional vapor treatment technologies, conclusions derived from the data collected, recommendations on the applicability of the technology for SS-42, and, if appropriate, estimates of full-scale treatment capital and operating costs.

An example outline of the contents of the evaluation report is shown below.

1.0 INTRODUCTION

- 1.1 Scope and Objectives of Demonstration
- 1.2 Site History

2.0 DESCRIPTION OF TECHNOLOGY

- 2.1 ICE System
- 2.2 Vendor's Statement of System Capabilities and Costs
 - 2.2.1 Capabilities
 - 2.2.2 System Support and Specifications
 - 2.2.3 Vendor Costs
- 2.3 Regulatory Acceptance

3.0 FIELD DEMONSTRATION RESULTS

- 3.1 Summary of Site Conditions
- 3.2 Regulatory Approval and Requirements
- 3.3 Test Conditions
 - 3.3.1 Soil Vapor Concentrations/Flow Rates
 - 3.3.12 ICE Configuration
- 3.4 Observed Performance
 - 3.4.1 Treatment Efficiency
 - 3.4.2 Cost of Operation

3.4.3 Comparison of ICE System Costs to Other Treatment Technologies

3.4.4 Reliability and Maintainability

4.0 SUMMARY

4.1 Technology Performance

4.2 Cost

4.3 Application of Full-Scale Design

4.0 REFERENCES

APPENDICES

Note: Supporting figures and tables will be included in the evaluation report.

SECTION 6
REGULATORY NOTIFICATION

The Luke AFB point of contact will be the liaison for all regulatory contact regarding the SVE/ICE demonstration at Site SS-42. Parsons ES will be conducting this demonstration based on documentation of regulatory approval of the testing received by Luke AFB (see Appendix D). Additionally, Parsons ES understands that the maximum allowable TVH emissions from the ICE system to be tested at Site SS-42 is 3.0 pounds per day. Included in Appendix D is a letter dated June 17, 1996 to the Maricopa County Division of Air Pollution Control submitted by Luke AFB which provides the supporting documentation and calculations requested by the regulators. Based on this information, Luke AFB has received written approval from Mr. Dale Lieb, of the Maricopa County Division of Air Pollution Control, to conduct the demonstration (see Appendix D).

SECTION 7

LUKE AFB SUPPORT REQUIREMENTS

The following Base support is needed before mobilization of equipment and the Parsons ES pilot test team to Luke AFB:

- Assistance in obtaining regulatory approval (e.g., an emissions permit, if required);
- Assistance in obtaining approval from the Base to install and operate the VR Systems Model V3 ICE unit; and
- Provision of any paperwork required to obtain gate passes for Parsons ES and VR Systems employees and one propane distributor representative.

During the approximate 12-month period of ICE system operation, Base personnel will be requested to perform the following activities:

- If Base personnel are available, check the ICE system once each day to ensure that the system is operating.
- Arrange site access for Parsons ES and VR Systems, Inc. technicians to conduct periodic system monitoring (e.g., month sampling) and maintenance activities.
- Provide disposal of any condensate liquids collected during the ICE demonstration.
- If problems develop with the ICE unit or the SVE system, notify Mr. Steve Archabal of Parsons ES Phoenix at (602) 852-9110 or Mr. Pete Guest of Parsons ES Denver at (303) 831-8100.

SECTION 8
PROJECT SCHEDULE

The following schedule is proposed for the SVE/ICE demonstration project:

<u>EVENT</u>	<u>START DATE</u>	<u>FINISH DATE</u>
Initial Site Visit	June 26, 1996	June 26, 1996
Work Plan	June 27, 1996	August 22, 1996
Delivery of ICE System to Luke AFB	July 31, 1996	August 2, 1996
Mobilization	August 5, 1996	August 12, 1996
ICE System Startup	August 13, 1996	August 19, 1996
Demonstration	August 20, 1996	August 21, 1997
Demobilization	August 26, 1997	August 30, 1997
Preparation of Site-Specific Evaluation Report	August 26, 1997	November 7, 1997

SECTION 9

POINTS OF CONTACT

This section provides the names, addresses, and telephone numbers of designated personnel who will serve as key points of contact during the SVE/ICE demonstration at Luke AFB.

CLIENT

Contracting Officer's Representative

Captain Ed Marchand
AFCEE/ERT
3207 North Road, Bldg 532
Brooks AFB, TX 78235-5363
Phone Direct (210) 536-4364
Phone General (210) 536-4331
Fax (210)536-4330

Air Force Technical Support

Mr. Dan Kraft
Booz•Allen & Hamilton, Inc.
8001 Arnold Drive, Bldg. 642
Brooks AFB, TX 78235-5357
Phone (210) 536-4361
Fax (210)536-4330

CONTRACTOR

Parsons Engineering Science, Inc.

Mr. Pete Guest, Project Manager
Mr. Doug Downey, Technical Director
Parsons Engineering Science, Inc.
1700 Broadway, Suite 900
Denver, Colorado 80290
Phone (303) 831-8100
Fax (303) 831-8208

Mr. R.C. Wooten, Program Manager
Parsons Engineering Science, Inc.
8000 Centre Park Drive, Suite 200
Austin, Texas 78754
Phone (512) 719-6000
Fax (512) 719-6099

Mr. Steve Archabal, Site Manager
Parsons Engineering Science, Inc.
3875 N. 44th Street, Suite 250
Phoenix, Arizona 85108
Phone (602) 852-9110
Fax (602) 852-9112

LUKE AFB

Mr. Jeff Rothrock, Restoration Section Chief
56 CES/CEV
13970 W. Lightning Street
Luke AFB, Arizona 85309-1149
Phone (602) 856-8490
Fax (602) 856-3817

Mr. Brian N Johnson
Geraghty & Miller, Inc.
8222 South 48th Street, Suite 140
Phoenix, AZ 85044
Phone (602)438-0883
Fax (602) 438-0102

SECTION 10
REFERENCES

Geraghty & Miller, Inc. 1996. Draft Bioventing Treatability Field Study Soil Permeability and In-Situ Respiration Tests Results, Analysis, and Recommendations, PSC SS-42, Luke Air Force Base, Arizona. February.

APPENDIX A
QUALITY ASSURANCE PROJECT PLAN

APPENDIX A

QUALITY ASSURANCE PROJECT PLAN

A.1 INTRODUCTION

The purpose of the quality assurance program is to ensure that the quality standards required to meet the project objectives are followed. The objective of the quality assurance project plan (QAPP) is to describe the procedures necessary to demonstrate that field testing, sample acquisition and analysis, review, verification, documentation, and reporting are performed to the quality standards outlined during this soil vapor extraction (SVE) and treatment demonstration.

A.1.2 Project Description

See Section 1 of this work plan addendum.

A.1.3 Quality Assurance Objectives

The primary objective of the Quality Assurance/Quality Control (QA/QC) program is to ensure that the procedures followed and data obtained during the course of the project are adequate to determine the feasibility of using the internal combustion engine (ICE) treatment system for volatile organic compound (VOC) off-gas abatement under a variety of conditions, and to ensure environmental compliance during the project. Specific objectives of the QA/QC program include the following:

- To ensure the use of proper investigative procedures and equipment in the field and the analytical laboratory;
- To specify the responsibilities of personnel included in the QA/QC program and how the program will be implemented; and
- To maintain a high level of quality during the field testing, data analysis, and report writing phases of the project.

A.2 ORGANIZATION AND STAFFING

The Organization and Staff responsibilities, including QA/QC responsibilities, are described in the project management plan.

A.3 LABORATORY TESTING QUALITY ASSURANCE OBJECTIVES FOR DATA MEASUREMENT

The quality assurance objectives for all laboratory analyses include considerations of precision, accuracy, completeness, representativeness, and comparability.

A.3.1 Precision

The precision of a measurement is an expression of mutual agreement of multiple measurement values of the same property conducted under prescribed similar conditions. Precision is evaluated most directly by recording and comparing multiple measurements of the same parameter on the same exact sample under the same conditions.

For laboratory analyses precision is expressed in terms of Relative Percent Difference (RPD). The RPD is calculated as follows:

$$\text{RPD} = \frac{(x_1 - x_2) 100}{(x_1 + x_2)/2}$$

where:

x_1 = analyte concentration of first duplicate; and

x_2 = analyte concentration of second duplicate.

Acceptable levels of precision will vary according to the sample matrix, the specific analytical method, and the analytical concentration relative to the method detection limit. Replicate standards and/or spiked samples will be used to estimate the precision of 10 percent (1 in 10) of the analytical test procedures for a known matrix.

A.3.2 Accuracy

The term accuracy refers to the correctness of the value obtained from analysis of a sample, and is determined by analyzing a sample and its corresponding method spike sample. Accuracy is expressed as Percentage Recovery (PR) and is calculated using the following formula:

$$\text{PR} = \frac{(A-B)}{C} \times 100$$

where:

- A = spiked sample result (SSR);
- B = sample result (SR); and
- C = spike added (SA).

The degree of accuracy and the recovery of analyte to be expected for the analysis of QA samples and spiked samples is dependent upon the matrix, method of analysis, and compound or element being determined. The concentration of the analyte relative to the detection limit is also a major factor in determining the accuracy of the measurement. The practical quantitation level for most analyses is generally stated in the analytical method. Certified standards and/or spiked samples will be used to estimate analyte recovery for each test procedure for a known matrix. The accuracy of Gas Chromatography/Mass Spectrometry (GC/MS) analyses is compound- and matrix-dependent. Method spike samples will be used to determine accuracy of the analyses of 10 percent of the analytical tests performed for this project.

A.3.3 Completeness

The completeness of the data is the amount of valid data obtained from the measurement system (field and laboratory) versus the amount of data expected from the system. At the end of each sampling event, an assessment of the completeness of data will be performed. Since resampling for laboratory analyses is not feasible, it is critical that holding times are met and that the laboratory inform the project manager of any delays. In addition, data completeness will be assessed prior to the preparation of data reports.

A.3.4 Representatives

Samples taken must be representative of the population. To assess the representativeness of the samples, some samples will be collected in duplicate. Comparisons of the results from the original sample and its field duplicate will allow for an evaluation of the representativeness of the samples.

A.3.5 Comparability

Where appropriate, the results of analyses obtained may be compared with the results obtained in previous studies. Consistency in the acquisition, handling, and analysis of samples by USEPA-recommended procedures is necessary in order that the results may be compared. To this end, standard solutions and materials used in calibrating field and laboratory analytical instruments must be traceable to National Bureau of Standards (NBS) or EPA standards, and published analytical methods will be followed. Any deviations from the specified analytical protocol will be documented by the laboratory.

A.4 SAMPLE HANDLING, SAMPLE RECEIPT

A.4.1 Sample Handling, Packaging, and Shipment

A.4.1.1 Sample Containers

Laboratory samples will be placed in pre-cleaned, 1-liter, evacuated SUMMA® canisters. The samples will be carefully packed for shipment. The SUMMA® canisters will be obtained from the analytical laboratory. A Chain-of-Custody Record describing the contents of the shipment will be placed in the shipment containers. When shipment containers are delivered to the shipping company, they will be securely taped shut with custody seals placed on the containers so they cannot be opened without breaking the seal.

A.4.1.2 Sample Labeling

Laboratory sample containers will be labeled, and labels will include the sample numbers, site designation, time and date sampled, and sampler's name.

A.4.1.3 Sample Numbering System

Each laboratory sample will be assigned a unique sample identification number that describes where the sample was collected. Each number will consist of a group of letters and numbers, separated by hyphens. The sample numbering system that will be used is unique to the site and location sampled. Table A.4.1 provides an example of the numbering system.

A.4.1.4 Holding Times

After samples have been taken, they will be delivered to the laboratory for analysis as soon as possible after collection in order to ensure that the most reliable and accurate answers will be obtained as a result of the analysis. The holding time begins from the date of collection in the field. The laboratory holding time for VOC soil gas analysis is 30 days.

A.4.2 Shipping Requirements

Shipping containers will be secured by using packaging tape and signed custody seals to ensure that the samples have not been disturbed during transport. The custody seals will be placed on the containers so they cannot be opened without breaking the seal.

Copies of the signed Chain-of-Custody forms will be delivered with the data packages. The originals will remain on file with the laboratory.

TABLE A.4.1

SAMPLE NUMBERING SYSTEM

The sample numbering system includes 3 identifying pieces of information separated by hyphens:

[Code for SITE] - [Code for Location] - [Flow Rate]

- Code for SITE - No more than 5 letters (separated by hyphen)
- Code for LOCATION - No more than 5 letters (separated by hyphen)
- Code for FLOW RATE (SCFM) - No more than 3 letters

Note: Total characters used for Sample Identification should not exceed 15 (this includes hyphens with no spaces).

Example Sample Numbers:

Luke-I01-120	Sample from Luke AFB, influent to the system, at a flow rate of 120 scfm.
Luke-E01-40	Sample from Luke AFB, effluent from the system, at a flow rate of 40 scfm.

A.4.3 Shipping Address

A.4.3.1 Soil Gas Samples

Air Toxics, Ltd.
180 Blue Ravine Road, Suite B
Folsom, CA 95630-4719
Attention: Chelsea Ingols
Phone: (916) 985-1000/(800) 985-5955

A.4.4 Sample Receipt

The laboratory will sign the Chain-of-Custody upon receipt, keep the original, and return a signed copy, which describes sample conditions upon receipt, back to the project manager. The condition of the samples will be documented in a signed, dated, and bound log book and on the Chain-of-Custody form with signature and date of person checking samples. If any damage or discrepancy arises between Chain-of-Custody, sample labels, and requested analysis, the sample custodian will notify the ES project manager immediately. Any damage or discrepancy will be noted by the laboratory as an out-of-control form with the corrective action taken. The out-of-control form will be signed and dated by the custodian and any other person responsible for corrective action.

A.5 SAMPLE CUSTODY

All samples will be accompanied by a Chain-of-Custody Record. A Chain-of-Custody Record will accompany the sample during shipment to the laboratory and through the laboratory. The Site Manager will maintain and send a copy of each Chain-of-Custody Record to the project administrator, ES Denver (303) 831-8208 for tracking purposes.

The information provided on the Chain-of-Custody Record will include:

- The project name and the Air Force Base name;
- The signature of the samplers;
- The sampling station number or sample number;
- Date and time of collection;
- Sample designation;
- Signature of individuals involved in the sample transfer;
- The time and date they receive the sample;
- The analytical methods required; and
- The number of containers of each sample.

Chain-of-Custody Records initiated in the field shall be placed in the shipping containers used for sample transport from the field to the laboratory. This record will be used to document sample custody transfer from the field sampler to the laboratory or to a Parsons ES office.

A.5.1 Sample Custody

A sample is under custody if:

- It is in your actual possession; or
- It is in your view, after being in your physical possession; or
- It was in your physical possession and then you locked it up to prevent tampering; or
- It is in a designated and identified secure area.

A.5.2 Transfer of Custody and Shipment

The following procedures will be used in transferring and shipping samples:

- Samples are accompanied by a Chain-of-Custody Record. When transferring the possession of samples, the individuals relinquishing and receiving will sign, date, and note the time on the Record. This Record documents transfer of custody of samples from the field sampler to another person, or to the laboratory.
- Samples will be properly packaged for shipment and dispatched to the appropriate laboratory for analysis with a separate signed Chain-of-Custody Record enclosed in each sample shipment container. The Chain-of-Custody Records will be numbered 1 of N, 2 of N, ..., where N is equal to the number of shipment containers shipped each day.
- Whenever samples are split with a facility or government agency, a separate Chain-of-Custody Record will be prepared for those samples and marked to indicate with whom the samples are being split.
- All packages will be accompanied by the Chain-of-Custody Record showing identification of the contents. The original Record will accompany the shipment and copies will be retained by the site manager and in the Parsons ES Denver office central project file.

A.5.3 Laboratory Custody Procedures

The analytical laboratory will, as a minimum, record and check all incoming samples for integrity, and note any observations on the original Chain-of-Custody Record. Each sample will be logged into the laboratory system by assigning it a unique sample number. This number and the field sample identification number will be recorded on the laboratory report. Samples will be stored and analyzed according to the specific USEPA methods. After the project is completed, the original

Chain-of-Custody Record will be returned to the project manager for permanent storage.

The following procedures will be used by the laboratory sample custodian in maintaining the Chain-of-Custody once the samples have arrived at the laboratory:

- The samples received by the laboratory will be cross-checked to verify that the information on the sample labels matches that on the Chain-of-Custody record included with the shipment;
- If all data and samples are correct, and there has been no tampering with the custody seals, the "received by laboratory" box is signed and dated; and
- The samples will be distributed to the appropriate analysts, with names of individuals who receive samples to be recorded in internal laboratory records.

For data that are input by an analyst and processed using a computer, a copy of the input shall be kept and identified with the project number and other information as needed.

If the data are directly acquired from instrumentation and processed, the analyst will verify that the following are correct:

- Project and sample numbers;
- Calibration constants and response factors;
- Output parameters such as units of measurement; and
- Numerical values used for detection limits if a value is reported as "less than".

A.6 ANALYTICAL PROCEDURES

Specific chemical parameters for the sampling program were selected based on suspected contaminants released at the Air Force Bases. The analytical program was designed to qualify and quantify the effect of soil vapor extraction using the ICE for VOC off-gas abatement on a variety of soil types, contamination concentrations, and under different climatic conditions.

All analyses will be performed within the holding time recommended for the specific test procedure and sample matrix. Samples will be collected and shipped in EPA recommended sample containers.

A.7 DATA REDUCTION, VALIDATION AND REPORTING

A.7.1 Field Measurement Data

Field measurements will be made by the site manager or the test engineer. The following standard reporting units will be used during all phases of the project:

- Pressure will be reported to 0.1 standard units on 5", 10", and 15" magnehelics, and reported in inches on larger magnehelics;
- Scfm will be reported to the nearest 1.0 scfm
- O₂ and CO₂ will be reported to 0.1 percent;
- TVH will be reported in ppmv on the appropriate scale;
- Extracted soil sampling depths will be reported to the nearest 0.5 foot interval.

Field data will be validated using three different procedures as follows:

- Routine checks will be made during the processing of data. An example is looking for errors in identification codes.
- Internal consistency of a data set will be evaluated. This step may involve plotting the data and testing for outliers.
- Checks may be made for consistency with parallel data sets, that is, data sets obtained presumably from the same population (for example, from the same volume of soil).

The purpose of these validation checks and tests is to identify outliers; that is, an observation that does not conform to the pattern established by other observations. Outliers may be the result of transcription errors or instrumental breakdowns. Outliers may also be manifestations of a greater degree of spatial or temporal variability than expected.

After an outlier has been identified, a decision concerning its fate must be rendered. Obvious mistakes in data will be corrected when possible, and the correct value will be inserted. If the correct value cannot be obtained, the data may be excluded. An attempt will be made to explain the existence of the outlier. If no plausible explanation can be found for the outlier, it may be excluded, but a note to that effect will be included in the report.

A.7.2 Data Analysis and Reporting

During data analysis and report preparation, the accuracy of numbers, calculations, tables, and figures will be reviewed and confirmed. In addition, the technical content of the report will be reviewed by the project manager and site manager and the report will be edited for syntax, grammar, composition, and printed quality. Data analysis reports will be issued to Parsons ES Denver within 10 days of receipt of samples. All data packages will be submitted to the project or site manager. A copy of the Chain-of-Custody Record will be submitted with the analysis results.

A.7.3 Maintenance of Project Documents

See Procedures for Project Administration of the PMP, Section 7.

A.8 FIELD AND LABORATORY CONTROL CHECKS

A.8.1 Field Quality Control Samples

During each sampling effort, a number of quality control (QC) samples (field duplicates must be collected and submitted for laboratory analysis. The number and frequency of the QC sample collection will be 10 percent (or 1 in 10 samples). Field duplicates are soil and soil gas samples collected in duplicate and submitted for laboratory analysis. Field duplicates will be labeled in such a manner so that persons performing laboratory analyses will not be able to distinguish duplicates from other collected samples.

A.8.1.1 Field Duplicates

Ten percent of all soil gas samples will be collected in duplicate and submitted for laboratory analysis. Field duplicates will be labeled in such a manner so that persons performing laboratory analyses will not be able to distinguish duplicates from other collected samples.

A.8.2 Laboratory QA/QC Samples

Quality control data are necessary to determine the absence of interferences and contamination of glassware and reagents. All required method QA/QC protocol shall be applied to each sample set at a frequency specified within the method. Matrix spike and spike duplicate analyses are performed for each matrix type. Duplicate samples and/or matrix spike duplicate samples will be analyzed with each set of samples, (1 in 20 samples) or 5 percent.

A.8.2.1 Analytical Duplicate Analyses

Analytical duplicate samples are aliquots of a single sample that are split on arrival at the laboratory or upon analysis.

A.8.2.2 Method Spike Analyses

This technique is used to determine the effect of matrix interference on the results for the GC/MS methods. Spikes are added at concentrations specified in the method. The percent difference between the values of the method spikes is taken as a measure of the precision of the analytical method.

The final concentration after spiking should be within the same range as the samples being analyzed to avoid the need for dilution, attenuation of instrument outputs, or other required alterations in the procedure which might affect the instrument response and determination of accuracy. Method spike analyses will be recorded on a 10-percent basis and submitted with the analytical results.

A.9 PREVENTIVE MAINTENANCE

All field equipment, instruments, tools, gauges, and other items requiring preventive maintenance will be serviced in accordance with the manufacturer's specified

recommendations. Maintenance records will be documented and traceable to specific equipment.

All laboratory instruments will be maintained in accordance with the standard operating procedures for each instrument. All maintenance will be documented for each analytical instrument.

A.10 CORRECTIVE ACTION

The following procedures have been established to assure that conditions adverse to quality including malfunctions, deficiencies, deviations, and errors are promptly investigated, documented, evaluated, and corrected.

When a significant condition adverse to quality is noted at the project site, laboratory, or subcontractor locations, the cause of the condition will be determined and corrective action taken to preclude repetition. Condition identification, cause, reference documents, and corrective action planned to be taken will be documented and reported to the Project Manager, Quality Assurance Manager, Site Manager, and involved subcontractor management, as a minimum. Implementation of corrective action will be verified by documented follow-up action. All project personnel have the responsibility, as part of the normal work duties, to promptly identify, solicit approved correction, and report conditions adverse to quality.

Corrective actions may be initiated for the following conditions as a minimum:

- When predetermined acceptance standards are not attained (objectives for precision, accuracy and completeness);
- When procedures or data compiled are determined to be faulty;
- When equipment or instrumentation is found faulty;
- When samples and test results cannot be traced with certainty;
- When quality assurance requirements have been violated;
- When designated approvals have been circumvented;
- As a result of system and performance audits; or
- As a result of a management assessment.

APPENDIX B

**LUKE AFB ADDENDUM TO THE ICE DEMONSTRATION
PROGRAM HEALTH AND SAFETY PLAN**

ADDENDUM TO THE PROGRAM HEALTH AND SAFETY PLAN
FOR THE EVALUATION OF
SOIL VAPOR EXTRACTION USING
INTERNAL COMBUSTION TECHNOLOGY

AT

LUKE AIR FORCE BASE
ARIZONA

JULY 1996

Prepared by

PARSONS ENGINEERING SCIENCE, INC.
1700 Broadway, Suite 900
Denver, CO 80290

REVIEWED AND APPROVED BY

	Name	Date
Project Manager	<u>Peter R. Guest.</u>	<u>7/18/96</u>
Office Health and Safety Representative	<u>Justin Mustard</u>	<u>7/18/96</u>

B.1.0 INTRODUCTION

This addendum modifies the existing program health and safety plan entitled *Program Health and Safety Plan for the Evaluation of Soil Vapor Extraction Using Internal Combustion Technology*. (Parsons Engineering Science, Inc., 1996) for the evaluation of internal combustion engine (ICE) vapor-phase treatment technology at Air Force installations across the United States.

Under contract number F41624-94-D-8136 Delivery Order 28, Air Force Center for Environmental Excellence (AFCEE), Brooks Air Force Base, Parsons Engineering Science, Inc. (Parsons ES) was requested to conduct ICE demonstrations to assist the Air Force in determining and evaluating the effectiveness and efficiency of the VR Systems, Inc. ICE systems for the destruction of nonchlorinated fuel hydrocarbon volatile organic compounds (VOCs) contaminating selected Air Force installations. The ICE has the potential to provide an effective, low-cost remedial approach for solvent-contaminated vadose zone soils. Activities to be performed include system installation and monitoring and demobilization.

This addendum to the program health and safety plan was prepared to address the upcoming tasks at Luke Air Force Base (AFB) in Arizona. Included or referenced in this addendum are the scope of services, site specific description and history, project team organization, hazard evaluation of physical hazards and of known or suspected chemicals, and emergency response information. All other applicable portions of the program health and safety plan remain in effect.

B.2.0 SCOPE OF SERVICES

The scope of services to be completed by Parsons ES will require the evaluation of the effectiveness and efficiency of the ICE system at Site SS-42, Luke AFB. The two-phase demonstration evaluation will focus on extraction flow rates, destruction efficiency for volatile organic compounds (VOCs) in the extracted soil gas, and operating costs. The first phase will consist of the installation of the ICE system with the performance of startup and optimization tests to verify VOC destruction efficiencies, establish flow rates, and optimize extracted soil gas concentrations. The second phase will consist of the operation and monitoring period for approximately 12 months, to determine system reliability, changes in site conditions, and operating costs. At the end of the second phase, the ICE system will be demobilized.

B.3.0 SITE SPECIFIC DESCRIPTION HISTORY

The site description and history for Site SS-42 are outlined in the work plan entitled *Work Plan for the Evaluation of Soil Vapor Extraction Using Internal Combustion Engine Technology, Luke Air Force Base, Arizona* (Parsons Engineering Science, Inc., 1996).

Site SS-42 is a former oil/water separator system located within the bulk fuels storage yard in the eastern portion of Luke AFB.

B.4.0 PROJECT TEAM ORGANIZATION

The project team assigned to the ICE demonstration activities at Luke AFB are identified in the program health and safety plan.

B.5.0 HAZARD EVALUATION

B.5.1 Chemical Hazards

The contaminants of concern at Site SS-42 are jet fuel and the fuel hydrocarbon components benzene, toluene, ethylbenzene, and xylenes (BTEX). Health hazard qualities for these compounds are presented in Table 5.1 of the program health and safety plan. If other contaminants are found to exist at the site, this addendum will be modified to include the necessary information which will then be communicated to the onsite personnel.

Material safety data sheets (MSDSs) will be available onsite at the ICE System for site-specific chemicals related to system operations (i.e., propane).

B.5.2 Physical Hazards

Potential physical hazards at Luke AFB are discussed in the program health and safety plan.

B.6.0 EMERGENCY RESPONSE PLAN

B.6.1 Emergency Contacts

In the event of any emergency, situation or unplanned occurrence requiring assistance, the appropriate contacts should be made from the list below. A list of emergency contacts must be posted at the site.

Contingency Contacts

All Emergency Services

Telephone Number

911 or
(602) 856-5970/5971 (if calling from a cellular phone)

Crime Stoppers (Crime Reporting)

(602) 856-6666

Poison Control Center

(800) 362-0101

Site Contact (Jeff Rothrock)

8490 (On-base), (602) 856-8490 (Off-base), (602) 953-0408 (Home)

Medical Emergency

Hospital

Walter O. Boswell Memorial Hospital

Address

10401 Thunderbird Boulevard
Sun City, Arizona

Telephone Number

(602) 976-5366 (Emergency Room)

Ambulance

911 (Base facilities will initially respond)

Directions to the Hospital

From Luke AFB, proceed out the Litchfield Road gate and turn left (north) onto Lichtfield Road. At Northern Avenue, turn right (east) and continue to 107th Avenue. Turn left (north) onto 107th Avenue and proceed to Thunderbird Boulevard. Turn right (east) onto Thunderbird Boulevard and continue to the hospital.

Parsons ES Contacts

Telephone Number

Pete Guest
Project Manager

(303) 831-8100 (Work)
(303) 988-2459 (Home)

Steve Archabal
Site Manager

(303) 831-8100 (Work - prior to 08/19/96)
(602) 852-9110 (Work - after 08/19/96)

Tim Mustard, CIH
Program Health and Safety Manager

(303) 831-8100 (Work)
(303) 450-9778 (Home)

Ed Grunwald, CIH
Corporate Health and Safety Manager

(404) 325-0770 (Work)
(404) 299-9970 (Home)

Judy Blakemore
Assistant Program Health and Safety
Manager

(303) 831-8100 (Work)
(303) 828-4028 (Home)

APPENDIX C

SITE SS-42 ANALYTICAL DATA

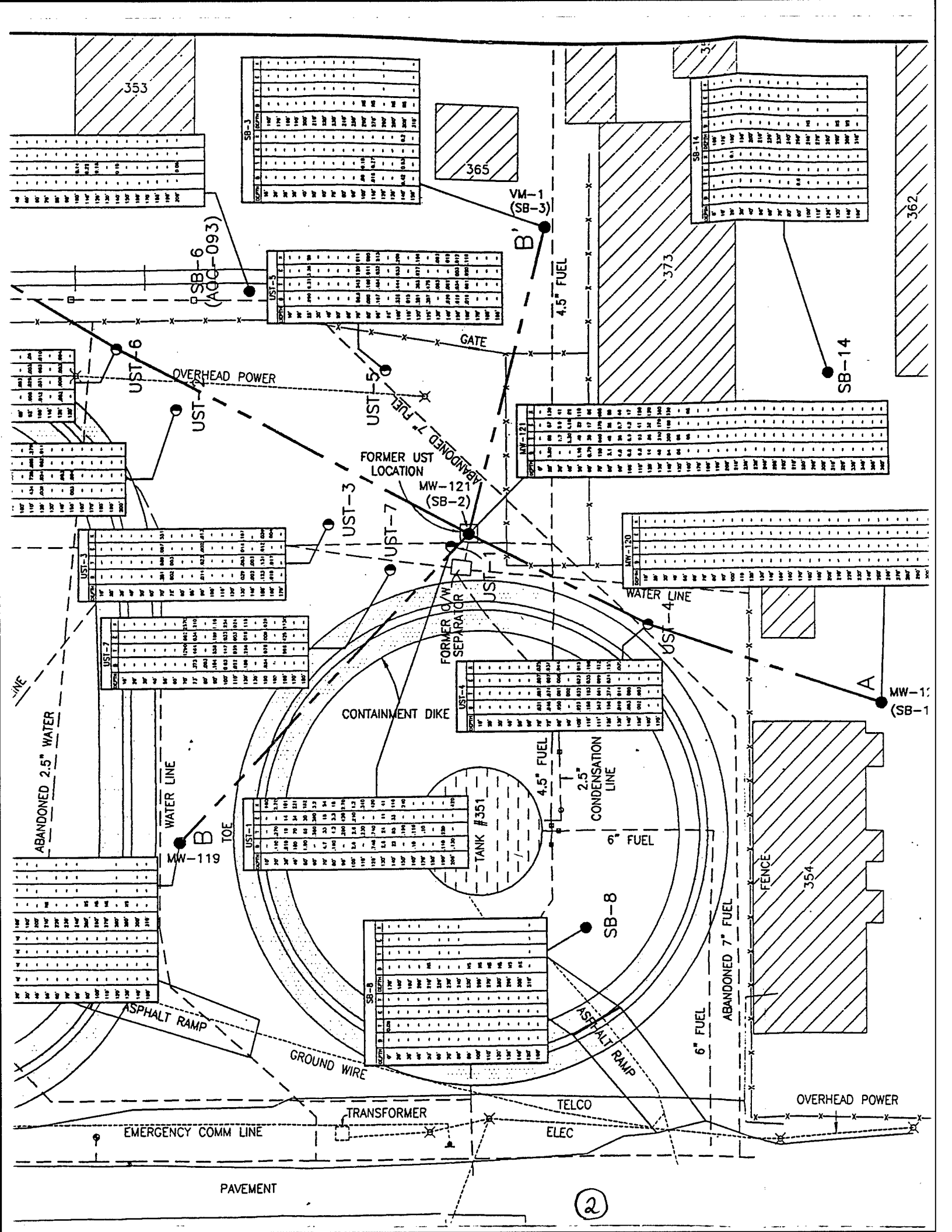

353

365

362

SB-6
(AGG-093)

VM-1
(SB-3)

SB-14

UST-6

OVERHEAD POWER

UST-4

FORMER UST
LOCATION

UST-5

UST-3

UST-7

MW-121
(SB-2)

FORMER C/W
SEPARATOR

WATER LINE

UST-4

CONTAINMENT DIKE

ABANDONED 2.5" WATER

WATER LINE

MW-119

TOE

TANK #351

4.5" FUEL

2.5" CONDENSATION
LINE

6" FUEL

SB-8

FENCE

354

ABANDONED 7" FUEL

6" FUEL

ASPHALT RAMP

GROUND WIRE

ASPHALT RAMP

EMERGENCY COMM LINE

TRANSFORMER

TELCO

ELEC

OVERHEAD POWER

PAVEMENT

2

DWG DATE: 4/4/95 | PRACT NO.: | FILE: LUKE\TREAT | DRAWING: SS42-TPH | CHECKED: KNIGHT | APPROVED: STEM | DRAFTER: STILES

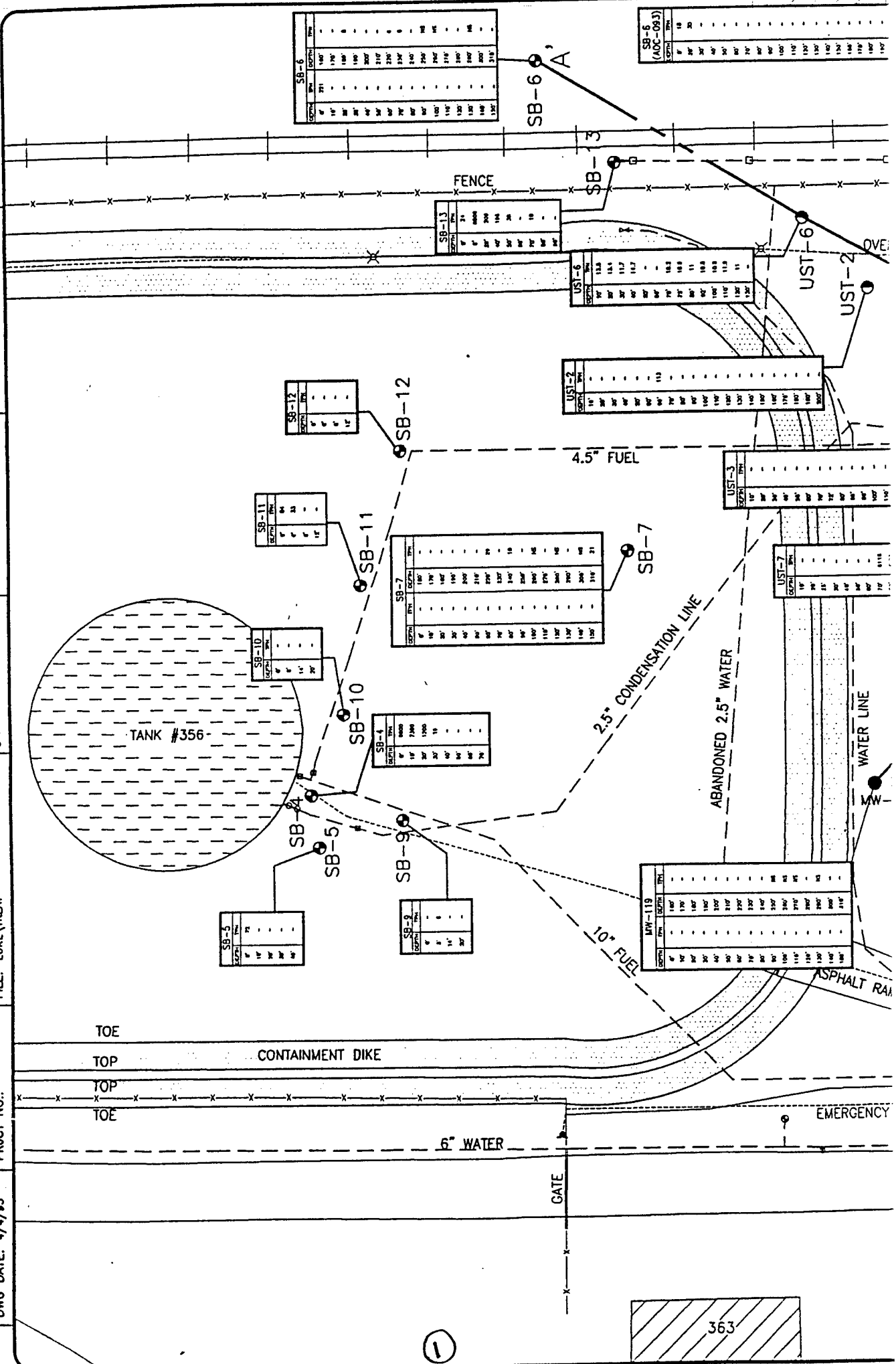

SB-6	
DEPTH	TIME
10'	190'
20'	180'
30'	170'
40'	160'
50'	150'
60'	140'
70'	130'
80'	120'
90'	110'
100'	100'
110'	90'
120'	80'
130'	70'
140'	60'
150'	50'
160'	40'
170'	30'
180'	20'
190'	10'
200'	0'

SB-6 (ACC-093)	
DEPTH	TIME
10'	18
20'	20
30'	22
40'	24
50'	26
60'	28
70'	30
80'	32
90'	34
100'	36
110'	38
120'	40
130'	42
140'	44
150'	46
160'	48
170'	50
180'	52
190'	54
200'	56

SB-13	
DEPTH	TIME
10'	24
20'	20
30'	16
40'	12
50'	8
60'	4
70'	0

UST-6	
DEPTH	TIME
10'	13.8
20'	13.5
30'	13.2
40'	12.9
50'	12.6
60'	12.3
70'	12.0
80'	11.7
90'	11.4
100'	11.1
110'	10.8
120'	10.5
130'	10.2
140'	9.9
150'	9.6
160'	9.3
170'	9.0
180'	8.7
190'	8.4
200'	8.1

UST-2	
DEPTH	TIME
10'	11.2
20'	11.0
30'	10.8
40'	10.6
50'	10.4
60'	10.2
70'	10.0
80'	9.8
90'	9.6
100'	9.4
110'	9.2
120'	9.0
130'	8.8
140'	8.6
150'	8.4
160'	8.2
170'	8.0
180'	7.8
190'	7.6
200'	7.4

SB-12	
DEPTH	TIME
10'	12
20'	11
30'	10
40'	9
50'	8
60'	7
70'	6
80'	5
90'	4
100'	3
110'	2
120'	1
130'	0

SB-11	
DEPTH	TIME
10'	6
20'	5
30'	4
40'	3
50'	2
60'	1
70'	0

SB-7	
DEPTH	TIME
10'	21
20'	20
30'	19
40'	18
50'	17
60'	16
70'	15
80'	14
90'	13
100'	12
110'	11
120'	10
130'	9
140'	8
150'	7
160'	6
170'	5
180'	4
190'	3
200'	2
210'	1
220'	0

UST-3	
DEPTH	TIME
10'	11.0
20'	10.8
30'	10.6
40'	10.4
50'	10.2
60'	10.0
70'	9.8
80'	9.6
90'	9.4
100'	9.2
110'	9.0
120'	8.8
130'	8.6
140'	8.4
150'	8.2
160'	8.0
170'	7.8
180'	7.6
190'	7.4
200'	7.2

UST-7	
DEPTH	TIME
10'	11.8
20'	11.6
30'	11.4
40'	11.2
50'	11.0
60'	10.8
70'	10.6
80'	10.4
90'	10.2
100'	10.0
110'	9.8
120'	9.6
130'	9.4
140'	9.2
150'	9.0
160'	8.8
170'	8.6
180'	8.4
190'	8.2
200'	8.0

SB-4	
DEPTH	TIME
10'	1100
20'	1100
30'	1100
40'	1100
50'	1100
60'	1100
70'	1100
80'	1100
90'	1100
100'	1100
110'	1100
120'	1100
130'	1100
140'	1100
150'	1100
160'	1100
170'	1100
180'	1100
190'	1100
200'	1100

SB-5	
DEPTH	TIME
10'	24
20'	24
30'	24
40'	24
50'	24
60'	24
70'	24
80'	24
90'	24
100'	24
110'	24
120'	24
130'	24
140'	24
150'	24
160'	24
170'	24
180'	24
190'	24
200'	24

SB-9	
DEPTH	TIME
10'	30
20'	30
30'	30
40'	30
50'	30
60'	30
70'	30
80'	30
90'	30
100'	30
110'	30
120'	30
130'	30
140'	30
150'	30
160'	30
170'	30
180'	30
190'	30
200'	30

BW-119	
DEPTH	TIME
10'	180'
20'	180'
30'	180'
40'	180'
50'	180'
60'	180'
70'	180'
80'	180'
90'	180'
100'	180'
110'	180'
120'	180'
130'	180'
140'	180'
150'	180'
160'	180'
170'	180'
180'	180'
190'	180'
200'	180'
210'	180'
220'	180'
230'	180'
240'	180'
250'	180'
260'	180'
270'	180'
280'	180'
290'	180'
300'	180'

1

363

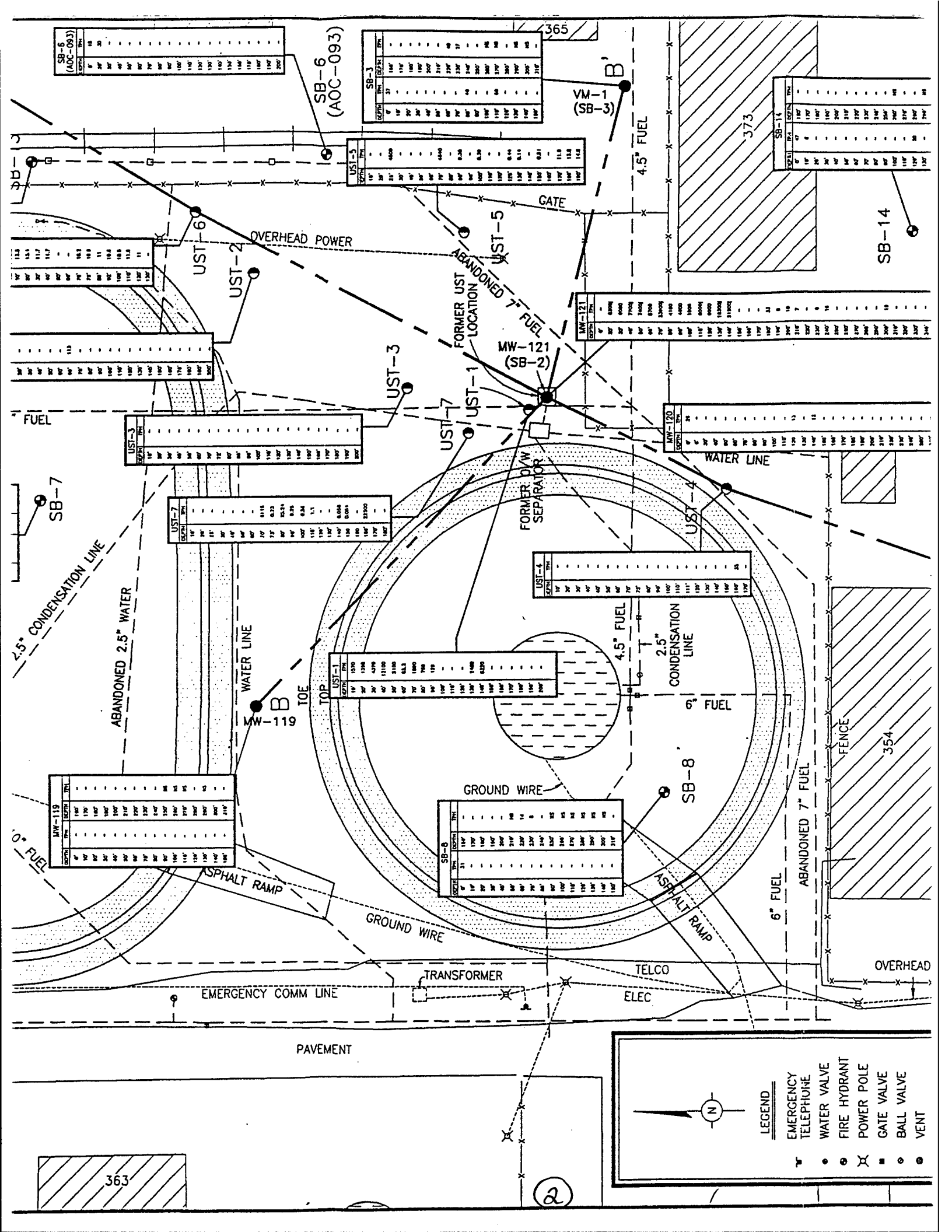

SB-6 (AOC-093)

DEPTH	TRK
18	200
20	200
22	200
24	200
26	200
28	200
30	200
32	200
34	200
36	200
38	200
40	200
42	200
44	200
46	200
48	200
50	200
52	200
54	200
56	200
58	200
60	200
62	200
64	200
66	200
68	200
70	200
72	200
74	200
76	200
78	200
80	200
82	200
84	200
86	200
88	200
90	200
92	200
94	200
96	200
98	200
100	200
102	200
104	200
106	200
108	200
110	200
112	200
114	200
116	200
118	200
120	200
122	200
124	200
126	200
128	200
130	200
132	200
134	200
136	200
138	200
140	200
142	200
144	200
146	200
148	200
150	200
152	200
154	200
156	200
158	200
160	200
162	200
164	200
166	200
168	200
170	200
172	200
174	200
176	200
178	200
180	200
182	200
184	200
186	200
188	200
190	200
192	200
194	200
196	200
198	200
200	200

SB-3

DEPTH	TRK
18	200
20	200
22	200
24	200
26	200
28	200
30	200
32	200
34	200
36	200
38	200
40	200
42	200
44	200
46	200
48	200
50	200
52	200
54	200
56	200
58	200
60	200
62	200
64	200
66	200
68	200
70	200
72	200
74	200
76	200
78	200
80	200
82	200
84	200
86	200
88	200
90	200
92	200
94	200
96	200
98	200
100	200
102	200
104	200
106	200
108	200
110	200
112	200
114	200
116	200
118	200
120	200
122	200
124	200
126	200
128	200
130	200
132	200
134	200
136	200
138	200
140	200
142	200
144	200
146	200
148	200
150	200
152	200
154	200
156	200
158	200
160	200
162	200
164	200
166	200
168	200
170	200
172	200
174	200
176	200
178	200
180	200
182	200
184	200
186	200
188	200
190	200
192	200
194	200
196	200
198	200
200	200

SB-14

DEPTH	TRK
18	200
20	200
22	200
24	200
26	200
28	200
30	200
32	200
34	200
36	200
38	200
40	200
42	200
44	200
46	200
48	200
50	200
52	200
54	200
56	200
58	200
60	200
62	200
64	200
66	200
68	200
70	200
72	200
74	200
76	200
78	200
80	200
82	200
84	200
86	200
88	200
90	200
92	200
94	200
96	200
98	200
100	200
102	200
104	200
106	200
108	200
110	200
112	200
114	200
116	200
118	200
120	200
122	200
124	200
126	200
128	200
130	200
132	200
134	200
136	200
138	200
140	200
142	200
144	200
146	200
148	200
150	200
152	200
154	200
156	200
158	200
160	200
162	200
164	200
166	200
168	200
170	200
172	200
174	200
176	200
178	200
180	200
182	200
184	200
186	200
188	200
190	200
192	200
194	200
196	200
198	200
200	200

UST-5

DEPTH	TRK
18	200
20	200
22	200
24	200
26	200
28	200
30	200
32	200
34	200
36	200
38	200
40	200
42	200
44	200
46	200
48	200
50	200
52	200
54	200
56	200
58	200
60	200
62	200
64	200
66	200
68	200
70	200
72	200
74	200
76	200
78	200
80	200
82	200
84	200
86	200
88	200
90	200
92	200
94	200
96	200
98	200
100	200
102	200
104	200
106	200
108	200
110	200
112	200
114	200
116	200
118	200
120	200
122	200
124	200
126	200
128	200
130	200
132	200
134	200
136	200
138	200
140	200
142	200
144	200
146	200
148	200
150	200
152	200
154	200
156	200
158	200
160	200
162	200
164	200
166	200
168	200
170	200
172	200
174	200
176	200
178	200
180	200
182	200
184	200
186	200
188	200
190	200
192	200
194	200
196	200
198	200
200	200

MW-121

DEPTH	TRK
18	200
20	200
22	200
24	200
26	200
28	200
30	200
32	200
34	200
36	200
38	200
40	200
42	200
44	200
46	200
48	200
50	200
52	200
54	200
56	200
58	200
60	200
62	200
64	200
66	200
68	200
70	200
72	200
74	200
76	200
78	200
80	200
82	200
84	200
86	200
88	200
90	200
92	200
94	200
96	200
98	200
100	200
102	200
104	200
106	200
108	200
110	200
112	200
114	200
116	200
118	200
120	200
122	200
124	200
126	200
128	200
130	200
132	200
134	200
136	200
138	200
140	200
142	200
144	200
146	200
148	200
150	200
152	200
154	200
156	200
158	200
160	200
162	200
164	200
166	200
168	200
170	200
172	200
174	200
176	200
178	200
180	200
182	200
184	200
186	200
188	200
190	200
192	200
194	200
196	200
198	200
200	200

MW-120

DEPTH	TRK
18	200
20	200
22	200
24	200
26	200
28	200
30	200
32	200
34	200
36	200
38	200
40	200
42	200
44	200
46	200
48	200
50	200
52	200
54	200
56	200
58	200
60	200
62	200
64	200
66	200
68	200
70	200
72	200
74	200
76	200
78	200
80	200
82	200
84	200
86	200
88	200
90	200
92	200
94	200
96	200
98	200
100	200
102	200
104	200
106	200
108	200
110	200
112	200
114	200
116	200
118	200
120	200
122	200
124	200
126	200
128	200
130	200
132	200
134	200
136	200
138	200
140	200
142	200
144	200
146	200
148	200
150	200
152	200
154	200
156	200
158	200
160	200
162	200
164	200
166	200
168	200
170	200
172	200
174	200
176	200
178	200
180	200
182	200
184	200
186	200
188	200
190	200
192	200
194	200
196	200
198	200
200	200

UST-7

DEPTH	TRK
18	200
20	200
22	200
24	200
26	200
28	200
30	200

APPENDIX D

**SUPPORTING REGULATORY AIR EMISSIONS
DOCUMENTATION**



DEPARTMENT OF THE AIR FORCE
AIR EDUCATION AND TRAINING COMMAND

File: 13C-10-F-5-0

17 June 96

Jeff Rothrock
Restoration Section Chief
56 CES/CEVR
13970 W Lightning Street
Luke AFB AZ 85309-1149

Mr Dale Lieb
Maricopa County Division of Air Pollution Control
2406 S 24th Street, Suite E-204
Phoenix, Arizona 85034

Dear Dale

Per our recent telephone conversations here are calculations to give you an idea of the anticipated emissions from the internal combustion engine (ICE) to be used in the remediation of our CERCLA site SS-42 Bulk Fuels Storage Area. The calculations for NOx and CO are derived from data furnished by the vendor for start up and the first few hours of operation (attachment 1) and should be considered worst case since actual stack sampling of the unit at Davis-Monthan AFB showed non-detect for NOx and .02% for CO (attachment 2). The calculation for pounds of total fuels emitted per day is site specific based on soil vapor analytical data obtained by Geraghty & Miller during soil permeability and in-situ respiration tests conducted at the site (attachment 3). The destruction efficiency used (99.9%) is based on observations of the unit at Davis-Monthan AFB which actually showed >99.9% (attachment 4).

CALCULATION FOR ENGINE INTAKE FLOW

$$\frac{\text{ENG DISP. X RPM}}{2} = \frac{\text{CUBIC INCHES}}{1728 \text{ cu in/cu ft}} = \text{TOTAL SCFM X .4(volumetric eff.)} = \text{SCFM}$$

$$\frac{460 \text{ cu in X 2200}}{2} = \frac{506000 \text{ cu in}}{1728 \text{ cu in/cu ft}} = 292.8 \text{ X .4} = 117.1 \text{ SCFM}$$

CALCULATION FOR NOx & CO EMISSIONS

NOx = 80 ppmv

CO = 300 ppmv

Based on maximum exhaust flow rate of 250 cfm

$$\text{NOx} = (250 \text{ cfm})(80 \text{ ppm})(.000001)(1440 \text{ min})(46 \text{ lb/mole})/(379 \text{ cu ft/mole}) = 3.5 \text{ lbs/day}$$

$$\text{CO} = (250 \text{ cfm})(300 \text{ ppm})(.000001)(1440 \text{ min})(28 \text{ lb/mole})/(379 \text{ cu ft/mole}) = 8.0 \text{ lbs/day}$$

CALCULATION FOR TOTAL FUELS EMISSIONS

Total Fuels as measured by G&M = 130,000 ug/l

$$\frac{130000 \text{ ug}}{1} \times \frac{\text{g}}{1000000 \text{ ug}} \times \frac{\text{lb}}{454 \text{ g}} \times \frac{28.31}{\text{cu ft}} \times \frac{117 \text{ cu ft}}{\text{min}} \times \frac{60 \text{ min}}{\text{hr}} \times 24 \text{ hrs} = 1365 \text{ lbs/day}$$

99.9% destruction efficiency = .1% emitted

$$.001 \times 1365 \text{ lbs/day} = 1.365 \text{ lbs/day}$$

We will keep you informed of the project schedule as we approach the start-up date should you desire to inspect the unit. We certainly appreciate your assistance in this matter. Should you have any questions regarding this project or require additional information do not hesitate to contact me at #856-3815.

Sincerely

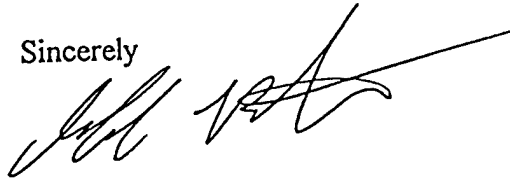

JEFF ROTHROCK
Restoration Section Chief

Attachments:

1. Vendor information NOx & CO
2. Stack analysis DM AFB
3. G&M analytical
4. Destruction efficiency

cc:

Capt Ed Marchand, AFCEE/ERT

-04' 9f

(TUE) 06:55
R. SYSTEMS

HQ AFCEE/ERT
TEL: 714-826-8746

TEL: 210 536 4330

P. 003

Jun 03'96 10:41 No. 002 P. 03

Evaluation Process and Procedures Used for the Certified Equipment Program for VR Systems Soil Remediation Equipment (VR-3) (Re-Evaluation)

Concentration limitations on exhaust gases as proposed by VR Systems:

- ROG: 50 PPMV *
- NOx: 80 PPMV
- CO 300 PPMV

Based on a maximum flow rate of 250 cfm as proposed by VR Systems, the following limitations in lbs/day are applied:

$$\text{ROG} = (250 \text{ cfm})(50 \text{ ppm})(10^{-6})(1440 \text{ min/day})(88 \text{ lb/mole})(379 \text{ ft}^3/\text{mole})$$

$$= 4.0 \text{ lbs/day}$$

$$\text{NOx} = (250 \text{ cfm})(80 \text{ ppm})(10^{-6})(1440 \text{ min})(46 \text{ lb/mole})(379 \text{ ft}^3/\text{mole})$$

$$= 3.5 \text{ lbs/day}$$

$$\text{CO} = (250 \text{ cfm})(300 \text{ ppm})(10^{-6})(1440 \text{ min})(28 \text{ lb/mole})(379 \text{ ft}^3/\text{mole})$$

$$= 8.0 \text{ lbs/day}$$

* Worst case per vendor (during start up & first few hours)

Current conditions on VR units are much less at Davis-Monthan AFB, AZ.
Capt Ed Mardund

Attachment 1

Table 4. Summary of Permeability Test Parameters, Bioventing Field Treatability Study, PSC SS-42, Luke Air Force Base, Arizona.

Parameter	Measurement Method	Units	Extraction Test			
			IW-1	IW-2	IW-3	Combined
Field Measurements						
Flow Rate	Pitot Tube	cfm	122	153	116	171
Applied Vacuum	Magnehelic Gage	"H ₂ O	99	83	108	50
Relative Humidity	Digital Hygrometer	percent	18.9	19.7	22	20.5
Temperature	Digital Thermometer	°F	93	93	97	95
Carbon Dioxide	LandTech GA-90	percent	11.7	10.3	0.3	9.9
Methane	LandTech GA-90	percent	>150	>150	134.7	>150
Oxygen	LandTech GA-90	percent	8.2	4.4	14	9.9
Total Organics	GasTech PID	ppmv	>9,999	7,600	>9,999	>9,999
Total Organics	OVA/FID	ppmv	>1,000	>1,000	>1,000	>1,000
Laboratory Analyses						
Carbon Dioxide	ASTM D1945	percent	13	11	0.7	11
Carbon Monoxide	ASTM D1945	percent	ND	ND	ND	ND
Methane	ASTM D1945	percent	ND	ND	ND	ND
Nitrogen	ASTM D1945	percent	78	82	84	79
Oxygen	ASTM D1945	percent	9.8	6.3	15	10
Total Fuels	USEPA TO-14	mg/m ³	70,000	200,000	42,000	<u>130,000</u>
Total Fuels	USEPA TO-14	ppmv	20,000	57,000	12,000	<u>37,000</u>
Benzene	USEPA TO-14	mg/m ³	1,400	9,600	610	4,900
Toluene	USEPA TO-14	mg/m ³	1,700	4,200	300	2,400
Ethyl Benzene	USEPA TO-14	mg/m ³	990	380	25	240
Xylenes	USEPA TO-14	mg/m ³	1,200	1,000	59	800

cfm Cubic feet per minute.
 "H₂O Inches of water.
 °F Degrees Fahrenheit.
 ppmv Parts per million by volume.
 mg/m³ Milligrams per cubic meter.

Attachment 3

Internal Combustion Engine (ICE)

Operation at Davis-Monthan AFB AZ

- ✓ Twin V8 engines (each 460 cubic inches)
- ✓ 140 scfm from 6 vent wells (500 scfm max)
- ✓ 2,200 lbs jet fuel per day
- ✓ >99.9% destruction*
- ✓ \$.07/lb (vs SVE+Thermal Oxidation @ \$.77/lb)
- ✓ Computer controlled w/remote via modem

* 0.54 lb/day(2.4 lb/day max [Pima County, AZ])



ENVIRONMENTAL SERVICES DEPARTMENT
AIR POLLUTION CONTROL
2406 South 24th Street, Suite E-204
Phoenix, Arizona 85034

(602) 506-6027, 6094
(602) 506-6925 (FAX)

July 10, 1996

Mr. Jeff Rothrock
Restoration Section Chief
56 CES/CEVR
13970 W. Lightning St.
Luke AFB, AZ 85309-1149

Dear Mr. Rothrock:

We have reviewed the proposed use of an internal combustion engine to be used for soil vapor extraction for CERCLA site SS-42 Bulk Fuels Storage Area and, based on the information provided with your June 17, 1996 letter, find that it meets the requirement of the Maricopa County Air Pollution Control Rules and Regulations.

If you have any questions, please give me a call at 506-6738.

Sincerely,

A handwritten signature in cursive script, appearing to read "Dale A. Lieb".

Dale A. Lieb
Manager, Title V Permitting

LSW:MLC

APPENDIX E

FIELD INSTRUMENTATION CALIBRATION PROCEDURES

APPENDIX E

FIELD INSTRUMENTATION CALIBRATION PROCEDURES

Oxygen and Carbon Dioxide

Gaseous concentrations of carbon dioxide (CO₂) and oxygen (O₂) will be analyzed using a GasTech Model 3252OX CO₂/O₂ analyzer or equivalent. The meter reads percent O₂ and CO₂ from 0 to 25 percent.

The battery charge level will be checked to ensure proper operation. The air filters will be checked and, if necessary, be cleaned or replaced before testing is started. The instrument will be turned on and equilibrated for at least 15 to 30 minutes before conducting calibration procedures or obtaining measurements. The sampling pump of the instrument will be checked to ensure that it is functioning correctly. Low flow of the sampling pump can indicate that battery level is low or that some fines are trapped in the pump or tubing.

The meter will be calibrated each day, prior to use, against purchased CO₂ and O₂ calibration standards. The CO₂ calibration will be performed against atmospheric CO₂ (0.05%) and a 5 percent standard. The O₂ will be calibrated using atmospheric O₂ (20.9%) and 0 percent standard. Standard gases will be purchased from a specialty gas supplier. To calibrate the instrument with standard gases, a Tedlar[®] bag (capacity ≈ 1 liter) is filled with the standard gas, and the valve on the bag is closed. The inlet nozzle of the instrument is connected to the Tedlar[®] bag, and the valve on the bag is opened. The instrument is then calibrated against the standard gas according to the manufacturer's instructions. Next, the inlet nozzle of the instrument is disconnected from the Tedlar[®] bag and the valve on the bag is shut off. The instrument will be rechecked against atmospheric concentration. If recalibration is required, the above steps will be repeated.

Hydrocarbon Concentration

Petroleum hydrocarbon concentrations will be analyzed using a GasTech Trace-Techtor[®] hydrocarbon analyzer (or equivalent) with range settings of 100 ppm, 1,000 ppm, and 10,000 ppm. The analyzer will be calibrated against a hexane calibration gas standard (4,400 ppm). Atmospheric or background air will be used as a zero reference during the two point calibration.

The O₂ concentration of the sample must be above 10 percent for the Trace-Techtor[®] analyzer to be accurate. When the O₂ drops below 10 percent, a dilution fitting (1:1) must be added at the inlet of the instrument to provide adequate oxygen for analysis.

HORIBA

INSTRUCTION MANUAL

MEXA-534GE

Automotive Emission Analyzer

3. PREPARATION

3-1. Sampling tube

- 1) Connect the sampling tube to the drain separator and the probe assembly. Tighten each joint with the hose bands.
- 2) Plug the drain separator into the sample inlet and twist to secure.

3-2. Filter elements

Make sure that clean filter elements are mounted in the pre-filter, dust filter, and strainer.

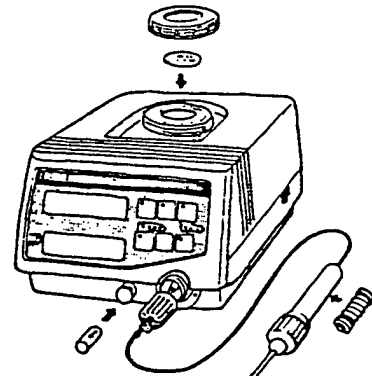

3-3. Power connection

IMPORTANT: Before connecting the power cable, check that the line voltage selector is set at the proper voltage.

A. To check the set voltage

- 1) Remove the fuse by pulling the FUSE PULL lever.
- 2) Move the FUSE PULL lever back to the right to see the set voltage on the card inside.
- 3) Put the fuse back if the set voltage is matched to your power line. Slide the cover back to the right for power connection.

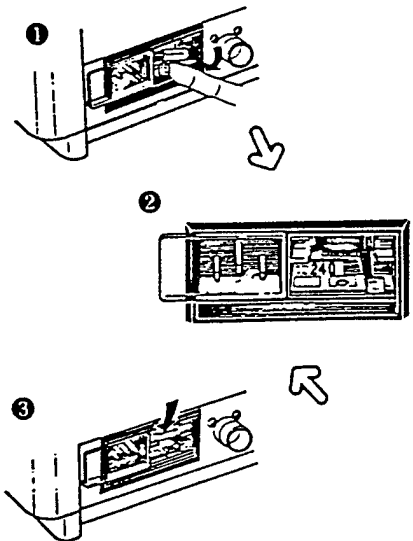

B. To reset the line voltage selector

1) Remove the fuse, and pull out the card as illustrated.

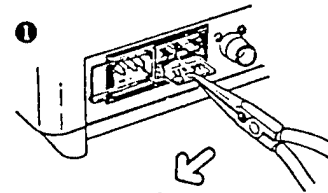

2) Set the voltage by inserting the card as shown in the diagram and insert a fuse rated at the set voltage*.

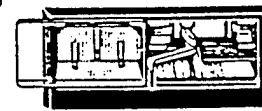

* 2A/125V fuse for 100 or 120V operation
1A/250V fuse for 220 or 240V operation

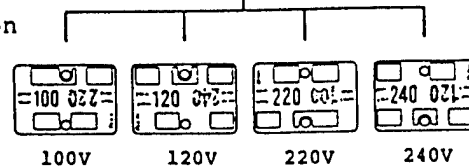

Turn the POWER SWITCH off and connect the power cable to the power line.

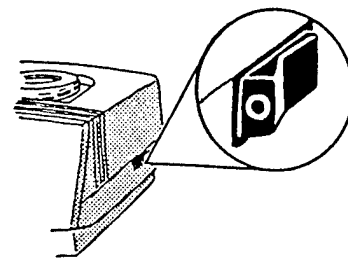



4. WARMING UP

1) Turn the POWER SWITCH on, and the analyzer will go into the STANDBY mode within two or three minutes.

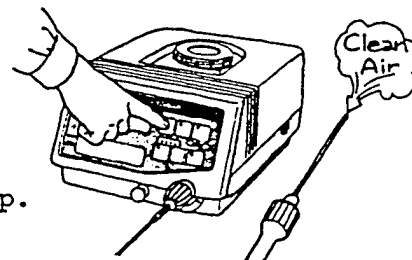
2) Press the PURGE key and keep the probe exposed to clean air.



3) Allow about ten minutes for warm-up.

4) Check that the , , and , marks aren't flashing, and then press the STANDBY key.

• The , mark will flash on the display if the analyzer takes in exhaust from vehicles in the PURGE mode.

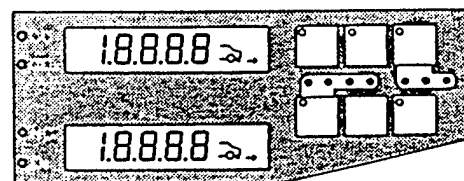

• Do not leave the probe tip on the floor.

5. CALIBRATION

Calibrate the analyzer before measuring the sample.

5-1. For CO/HC/CO₂ measurements

First, press the DISPLAY key to put the machine in CO/HC mode.

A. Zero calibration

1) Unplug the drain separator from the sample inlet, and press the PURGE key to let the analyzer take in clean air.

2) Press the AUTO ZERO key until both meters read "0."

3) Then, press the DISPLAY key to put the machine in CO₂/O₂ mode, and confirm that the upper meter (CO₂) reads "0."

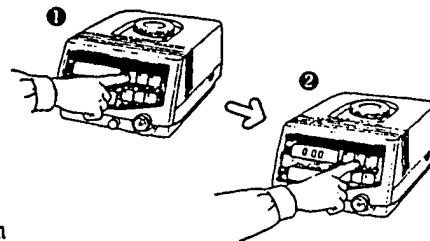

Note: The lower meter (O₂) may read around 21 vol%.

B. Span calibration

Press the DISPLAY key again to return to CO/HC mode.

1) Press the STANDBY key.

2) Press the span gas container nozzle into the span gas inlet for about 7~8 seconds.

3) Adjust the SPAN POT for CO and HC with the screwdriver provided until each meter reads the respective value on the span gas container. Then, press the DISPLAY key to put the machine in CO₂/O₂ mode, and adjust the SPAN POT for CO₂ in the same manner.

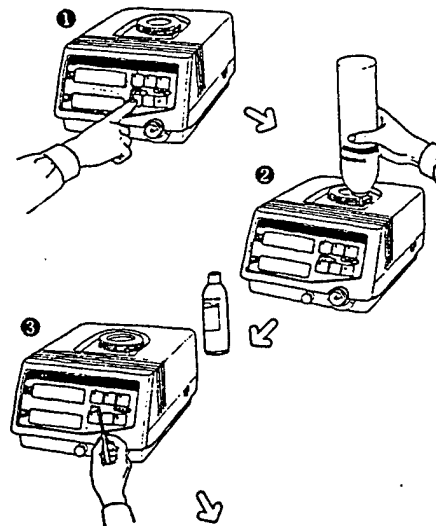

CAUTION: Do not touch the SPAN POT for O₂.
At this stage, the O₂ value reads around zero.

• Multiply propane (C₃H₈) concentration by 0.5 for n-hexane (n-C₆H₁₄) equivalent value.

4) Press the PURGE key. If the reading exceeds ±0.06 vol% for CO, ±30ppm for HC, or ±0.3 vol% for CO₂, repeat the above calibration procedures.

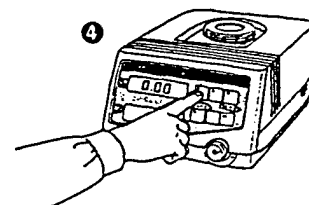

C. Checker trimmer adjustment (for CO, HC, and CO₂ only)

Adjust the appropriate CHECKER TRIMMER with the following procedures immediately after the span calibration.

- 1) Press the PURGE key to let the analyzer take in clean air.
- 2) Press the AUTO ZERO key until each meter reads "0."
- 3) Keep pressing the SPAN CHECK key and adjust the appropriate CHECKER TRIMMER with the screwdriver provided until the meter reads the value listed below.

CO: 5.00 ± 0.14 vol%
HC: 5000 ± 150 ppm
CO₂: 10.0 ± 0.45 vol%

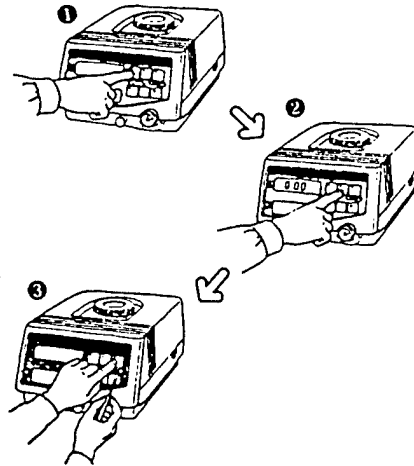

Note: Press the DISPLAY key to put the machine in the appropriate mode. There is no CHECKER TRIMMER for O₂.

IMPORTANT: Leave the CHECKER TRIMMER untouched until next span calibration.

5-1'. Quick span check

In routine operation the analyzer may be checked by following procedures for proper meter readings.

- 1) Unplug the drain separator, and press the PURGE key to let the analyzer take in clean air.
- 2) Press the AUTO ZERO key until all meters except the O₂ meter read "0."
- 3) Then, press the SPAN CHECK key to confirm that the meter reads the value listed below.

CO: 4.86-5.14 vol%
HC: 4850-5150 ppm
CO₂: 9.55-10.45 vol%

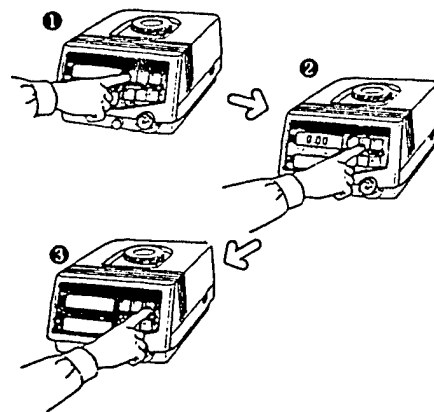

Adjust the appropriate SPAN POT with the screwdriver provided if the meter reading falls outside of the above range.

● Repeat procedures A through C of 5-1 in case the meter reading is not adjustable by the appropriate SPAN POT.

5-2. For O₂ measurement

Press the DISPLAY key to put the machine in CO₂/O₂ mode.

A. Zero calibration

Zero calibration is not normally necessary for O₂ measurement. When the O₂ SENSOR is replaced, calibrate the analyzer by referring to C below.

B. Span calibration

1) Press the PURGE key to let the analyzer take in clean air. If the O₂ value reads between 19.4 and 22.4 vol%, the analyzer can be used for O₂ measurement with an accuracy of ± 1.5 vol% O₂.

2) If the meter falls outside of the above range, adjust the SPAN POT for O₂ until the meter reads the span set value.

$$\text{Span set value (vol\%)} = 20.9 - (V \times \text{RH}/100)$$

where V is a number from the table below, and RH is the relative humidity (%) of ambient air.

Room temp (°C)	0	10	20	25	30	35	40
V	0.13	0.25	0.48	0.65	0.88	1.16	1.52

(Example) When the room temperature is 20°C and the relative humidity is 70%, the span set value will be;

$$20.9 - (0.48 \times 70/100) = 20.564 \approx 20.6 \text{ vol\%}$$

C. Replacement of O₂ SENSOR

Replace the O₂ SENSOR if the span calibration in B (2) cannot be performed.

1) Open the SENSOR BLOCK and pull the O₂ SENSOR out of the socket, then adjust the ZERO POT for O₂ on the SENSOR BLOCK until the meter reads "0."

2) Prepare the new O₂ SENSOR and plug it in the socket. Close the SENSOR BLOCK with the latches.

CAUTION: The performance of the O₂ SENSOR may decrease if it is left unconnected to the shorting plug. Do not touch the tip of the O₂ SENSOR, because it is made of a thin, fragile membrane.

3) Calibrate the span reading as described in B (2).

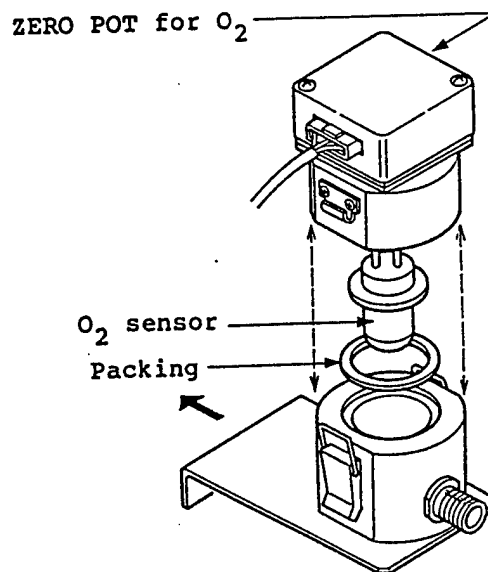

6. MEASUREMENT

Select the mode for CO/HC and CO₂/O₂ by pressing the DISPLAY key.

- 1) Unplug the drain separator from the sample inlet and press the PURGE key to let the analyzer take in clean air.

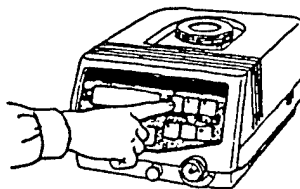

- 2) Press the AUTO ZERO key until the meter reads "0."

Note: The O₂ value may read around 21 vol%.

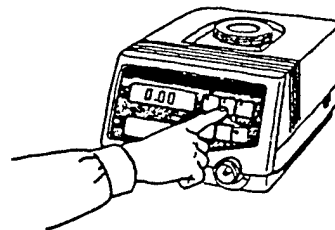

- 3) Plug the drain separator into the sample inlet.

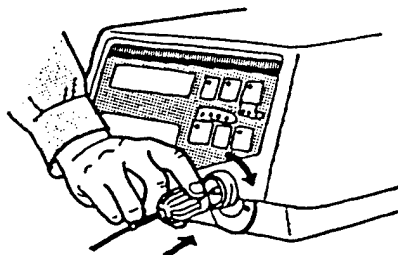

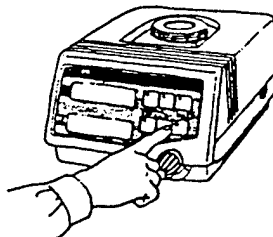

- 4) Press the MEASURE key.

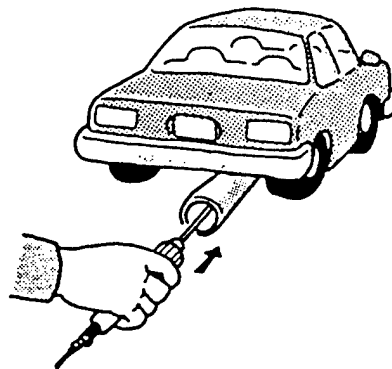

- 5) Insert the probe into the tail pipe sufficiently far enough*.

* An insufficient insertion may result in erroneous readings due to dilution of the exhaust sample with ambient air.



- The  mark will flash if the probe is positioned incorrectly.

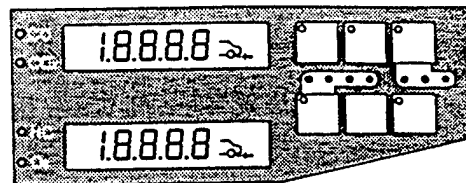

6) Press the DISPLAY key to set to the mode desired, and read the value on the meter.

- Never pump the accelerator of the vehicle during measurement.
- The vehicle must be idling at a constant rpm.
- The  mark flashes in CO/HC mode and the number 1.--- appears in CO₂/O₂ mode if the reading exceeds the measurement range.

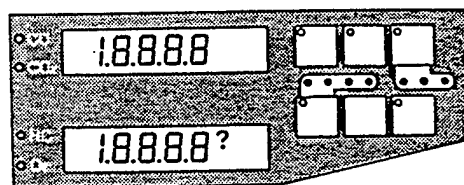

7) Remove the probe from the tail pipe and leave it exposed to clean air until the meter reads "0." Press the PURGE key.

Note: The O₂ value may read around 21 vol%.

For Successive Measurements

After step 7), repeat procedures 4) through 7).

- For accurate results, recalibrate the instrument before each measurement. Refer to instruction 5-1, 5-1', or 5-2.

For Shut-Down Procedures

After completing all measurements, let the analyzer take in clean air for at least 30 minutes in the PURGE mode before turning off the power.

7. ROUTINE MAINTENANCE

7-1. Replacement of filter element

1) If the OE mark is lit or the HORIBA logo on the dust filter becomes covered with dust, replace all the filter elements in the pre-filter unit, dust filter, and strainer.

2) For proper operation check all the filters at least once a day.

3) Under normal conditions with approx. one-minute measuring sequence each time, filter elements can be used for approx. 50 measurements of four-stroke engine vehicles or approx. 30 measurements of other types (powered by two-stroke or rotary engines).

• Measurement of emissions from diesel engine vehicles is not recommended.

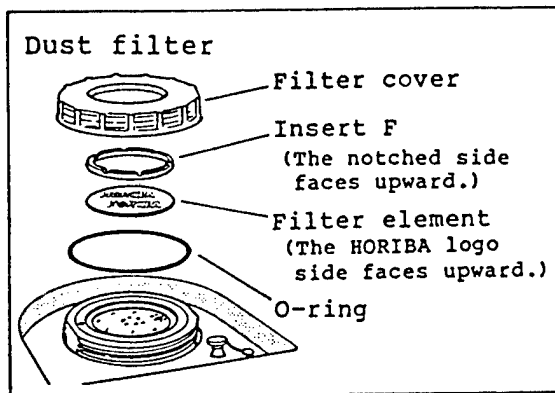
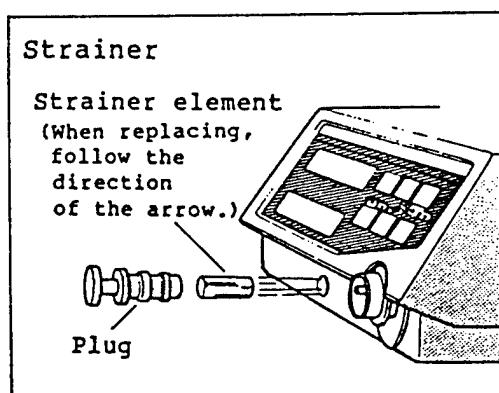
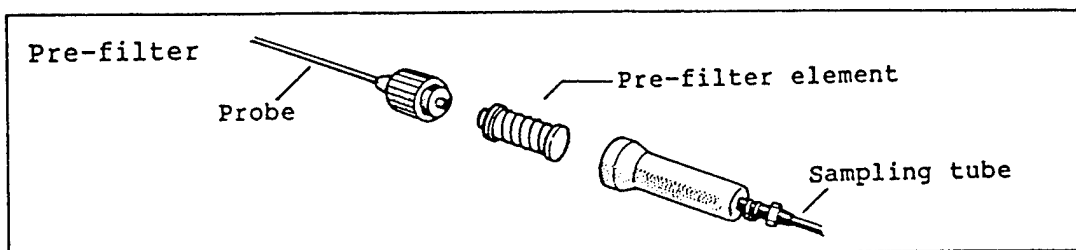

7-2. Replacement of probe

Replace the probe when a clog, crack, or pin-hole is found.