



Office of Graduate Studies  
University of South Florida  
Tampa, Florida

CERTIFICATE OF APPROVAL

Master's Thesis

This is to certify that the Master's Thesis of

SCOTT F. WALTER

with a major in Public Health has been approved by  
the Examining Committee on April 21, 2001  
as satisfactory for the thesis requirement  
for the Master of Science in Public Health degree.

Examining Committee:

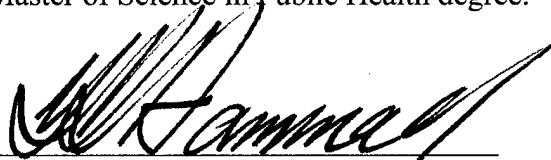
  
Major Professor: Yehia Hammad, Sc.D.

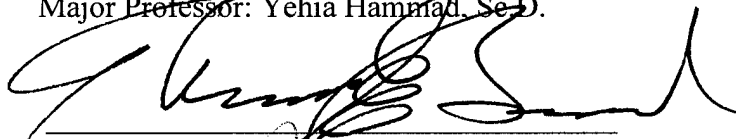
  
Member: Thomas Bernard, Ph.D.

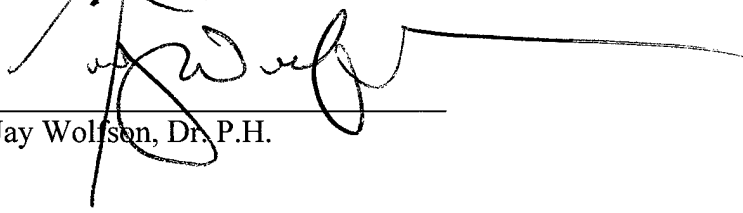
  
Member: Jay Wolfson, Dr. P.H.

APPLICATION OF SMOKE DETECTOR TECHNOLOGY TO MINIMIZE  
SMOKE EXPOSURES TO WILDLAND FIREFIGHTERS

by

SCOTT F. WALTER

A thesis submitted in partial fulfillment  
of the requirements for the degree of  
Master of Science in Public Health  
Department of Environmental and Occupational Health  
College of Public Health  
University of South Florida

May 2001

Major Professor: Yehia Hammad, Ph.D.

## TABLE OF CONTENTS

LIST OF TABLES	iii
LIST OF FIGURES	iv
LIST OF ABBREVIATIONS AND ACRONYMS	v
ABSTRACT	vii
CHAPTER 1. INTRODUCTION	1
Wildland Firefighters	2
Wildland Firefighting	3
Responsible Parties	3
Safety Measures and Equipment	4
Regulatory and Support Agencies	6
Prescribed Fires	8
Health Statistics	9
Respiratory Protection	10
CHAPTER 2. WILDLAND FIRES	12
Burning Process	13
Smoke Composition	15
Hazardous Components of Smoke	17
Acute Exposures	17
Chronic Exposures	19
Exposure Assessment	20
Size Distribution of Particulate Matter	20
Correlation Analysis	21
Cardiovascular Impairment	23
CHAPTER 3. SMOKE DETECTOR TECHNOLOGY	24
Ionization Detector Technology	24
Photoelectric Detector Technology	26
Sensitivity Settings	28
Limitations and Interferences	29
Applying the Technologies	27
Advantages of Using Smoke Detectors	30
Prototype	31

CHAPTER 4. TESTING OBJECTIVES	33
Testing Chamber	33
Accuracy and Precision	34
Detector Accuracy and Precision Testing	35
Testing Calculations	37
Air Velocity Testing	38
Velocity Testing Calculations	39
Reliability Issues	40
Other Issues	40
CHAPTER 5. RESULTS AND DISCUSSION	41
Smoke Chamber Testing Results	41
Accuracy and Precision Testing Conclusions	42
Air Velocity Testing Results for Photoelectric Detectors	43
Air Velocity Testing Results for Ionization Detectors	47
Reliability Issues	50
Conclusions	50
Recommendations	51
REFERENCES	53
BIBLIOGRAPHY	56
APPENDICES	57
Appendix A: Testing Methodology	58
Appendix B: Glossary	62
Appendix C: 10 Ten Standard Fire Orders and 18 Watchouts	65
Appendix D: Raw Data	66

## LIST OF TABLES

Table 1	Typical 8-hr Exposure Concentrations to Wildfire Smoke	20
Table 2	Typical Air Velocity Values	44
Table 3	Photoelectric Detector Response Times	66
Table 4	Photoelectric Detector Response Concentrations	66
Table 5	Ionization Detector Response Times	66
Table 6	Ionization Detector Response Concentrations	67
Table 7	Air Velocity Relationship for Photoelectric Detector Response	67
Table 8	High Air Velocity Relationship for Photoelectric Detector	67
Table 9	Airflow - Concentration Relationship for Photoelectric Detectors	68
Table 10	Air Velocity Relationship for Ionization Detector Response	68
Table 11	Airflow - Concentration Relationship for Ionization Detectors	69

## LIST OF FIGURES

Figure 1.	Typical Mass and Number Distributions of Smoke Particles	21
Figure 2.	Exposure Concentration Formulas Using Carbon Monoxide	22
Figure 3.	Irritant Index Exposure Formula	22
Figure 4.	Ionization Detector Diagram	25
Figure 5.	Photoelectric Detector Diagram	27
Figure 6.	Test Chamber Diagram	34
Figure 7.	Top View of Detector Test Area	35
Figure 8.	Test Chamber Smoke Concentration Plot	37
Figure 9.	Concentration Formulas and Calculations	37
Figure 10.	Top View of Test Area with Air Flow Information	38
Figure 11.	Chamber for Air Velocity Test	38
Figure 12.	Top View of Air Velocity Testing Platform	39
Figure 13.	Graph of Detector Accuracy and Precision Testing	42
Figure 14.	Velocity versus Response Time Graph for Photoelectric Detector	44
Figure 15.	High Velocity versus Response Time Graph	45
Figure 16.	Velocity versus Concentration Graph for Photoelectric Detector	46
Figure 17.	Velocity versus Response Time Graph for Ionization Detector	48
Figure 18.	Velocity versus Concentration Graph for Ionization Detector	49
Figure 19.	Prototype of Air Monitoring Device	51

## LIST OF ABBREVIATIONS AND ACRONYMS

ACGIH	American Conference of Governmental Industrial Hygienists
Am 241	Americium 241
BLS	Bureau of Labor Statistics
C	Smoke concentration ( $\text{mg}/\text{m}^3$ )
Co	Maximum smoke concentration ( $\text{mg}/\text{m}^3$ )
CO	Carbon Monoxide
dBa	Decibels A-weighted
Em	Equivalent exposure (irritant) index
FEMA	Federal Emergency Management Administration
fpm	Feet per minute
FS	Forest Service
G	Generation Rate (milligrams per minute)
HCHO	Formaldehyde
IDLH	Immediately Dangerous to Life and Health
LED	Light Emitting Diode
lpm	Liters per minute
$\text{mg}/\text{m}^3$	Milligrams of contaminant per cubic meter of air
MIC	Measuring Ionization Chamber
NIOSH	National Institute for Occupational Safety and Health
NFPA	National Fire Protection Association

NRC	Nuclear Regulatory Commission
OSHA	Occupational Safety and Health Administration
PEL	Permissible Exposure Limit
PAH	Polynuclear Aromatic Hydrocarbons
POM	Polycyclic Organic Matter
ppm	Parts per million
Q	Volumetric Flow Rate (liters per minute)
R <sup>2</sup>	Coefficient of determination
r	Radius from center of rotation to center of detector sensor (ft)
RPM	Respirable Particulate Matter
rpm	Revolutions per minute
Rx	Prescribed Fire
SCBA	Self-Contained Breathing Apparatus
STEL	Short-Term Exposure Limit
t	Elapsed time (minutes)
t <sub>f</sub>	Final time for purging cycle (minutes)
TLV	Threshold Limit Value
TWA	Time Weighted Average
UL	Underwriters Laboratory
USDA	United States Department of Agriculture
V	Volume (liters)
WL	Wildland Fire

APPLICATION OF SMOKE DETECTOR TECHNOLOGY TO MINIMIZE  
SMOKE EXPOSURES TO WILDLAND FIREFIGHTERS

by

SCOTT F. WALTER

*An Abstract*

of a thesis submitted in partial fulfillment  
of the requirements for the degree of  
Master of Science in Public Health  
Department of Environmental and Occupational Health  
College of Public Health  
University of South Florida

May 2001

Major Professor: Yehia Hammad, Ph.D.

Personnel who fight wildland fires are limited to the amount of protective equipment that they can carry with them. Bulky respiratory protection devices are considered extraneous to a smoke jumper who must carry all their tools and living necessities on their backs. In addition, respirators cannot filter out carbon monoxide, a significant airborne hazard from wildland fires. Instead, personnel are trained to recognize and avoid inhalation exposure situations eliminating the need for respiratory protection.

Most of the personnel who fight wildland fires are augmentees who are often poorly trained, lack experience, and are inadequately equipped to safely respond to the fire. In addition, wildland firefighters often lack the experience of responding to a large fire. Lastly, inhalation exposure conditions (concentrations, wind speed, wind direction, etc.) vary with each wildland fire encountered, which increases the exposure potential.

Most studies of the inhalation hazards from wildland fires indicate individual exposure levels of measurable contaminants were below the permissible exposure limits (PELs) established by the Occupational Safety and Health Administration (OSHA) with an incident overexposure rate of approximately 5 – 10 %. These exposures were attributed to lack of worker training or awareness of the existing inhalation hazard. The primary health effect reported was upper respiratory and eye irritation (mainly from acrolein, formaldehyde, and particulate matter exposure). For comfort, workers often wear scarves and bandanas to reduce the discomfort of smoke

exposure. For eye protection, some workers may wear goggles with limited protective capacity.

This study focused on the application of smoke detector technology to develop a low cost, disposable, effective, dependable personal alarm to alert wildland firefighters when potentially hazardous smoke conditions are encountered so that appropriate action can be taken. Smoke detector technology was considered due to the low unit costs created by the mass production of smoke detectors (unit costs under \$20 each). Two basic smoke detector technologies were considered for evaluation: ionization and photoelectric smoke alarms.

This study determined if smoke detector technology could be utilized for preventing exposures, which type of detection technology was the most effective, and evaluated the effectiveness of this type of a monitor to reduce both the short term and long term health hazards.

Abstract Approved: \_\_\_\_\_



Major Professor: Yehia Hammad, Dr. PhD.  
Professor, Department of Environmental and Occupational Health

Date Approved: \_\_\_\_\_

4/25/01

## **CHAPTER 1**

### **INTRODUCTION**

Due to drought conditions that have persisted for the last 10 or so years, the U.S. is in a national fire crisis (Babbitt 1999). Wildfires are on a sharp increase, burning bigger, threatening communities, and taking more and more property and lives. In the last decade, the number of acres burned has doubled; the number of lives lost has tripled (Babbitt 1999). The federal fire-fighting budgets have gone up 10 times since 1960 to a billion dollars a year. The recent wildfires of calendar year 2000 indicate this historical pattern of extensive wildfires is continuing due to persistent, unusual weather conditions. The result was an extended season with over 80,000 wildfires burning over 6.8 million acres simultaneously across the western United States (Lavery and Bosworth 2000). The future is grim as the Federal firefighting agencies are predicting really rough wildfire seasons in the next few years due to severe drought conditions. The continuing drought has made the calendar year 2000 fire season the worst in this half century (Craig 2000). Other environmental factors increase the risk for wildland fires. People across the country are moving into forested areas at an ever-increasing rate. In addition, more than 100 years of excluding fire, combined with past land-use practices, have altered the landscape. This has resulted in changes such as a heavy buildup of dead vegetation, dense stands of trees, a shift to species that have not evolved and adapted to fire, and, occasionally, even an increase in non-native fire-prone plants. Because of these conditions, today's fires tend to be

larger, burn hotter, and spread farther and faster, making them more severe, more dangerous, and more costly in human, economic, and ecologic terms (Babbitt and Glickman 2000).

### **Wildland Firefighters**

Firefighters are defined in the Fair Labor Standards Act (Public Law 106-151) as an employee who: "...is engaged in the prevention, control, and extinguishment of fires or response to emergency situations where life, property, or the environment is at risk. The activities included are: "fire fighter, paramedic, emergency medical technician, rescue worker, ambulance personnel, or hazardous materials worker." Full time personnel assigned to fight wildland fires are often combinations of Federal, State, and municipal employees usually well experienced, trained, and properly equipped. However, these wildland firefighting crews are often augmented by seasonal and temporary firefighters with limited experience or training. In addition, wildland firefighting organizations are facing a critical shortage of experienced, trained, professional wildland firefighters as experienced fire managers are finding work elsewhere due to pay inequalities, budget cuts, and incredibly hard work conditions (Udall 2000). More and more permanent employees with fire qualifications and experience are dodging fire assignments, at all levels of the fire management organization, from firefighter to manager. Consequently, the fire program increasingly will have to rely on less experienced people (Schaenman, Hodges et al. 1998). For example, in the 1998 Volusia County fire in Florida, the U.S. state and

federal forest services were so strapped for manning that “clerical people are out fighting fires...” (Sharp 1998).

### **Wildland Firefighting**

Work performed on a wildland fire suppression crew varies greatly, but duties mainly include fire line construction, slash burning, and fire suppression. Occupational requirements are defined as rigorous and demanding. Wildland firefighting demands a high level of fitness to safely perform physically demanding work in difficult environments. Wildland firefighters must be prepared to work in steep terrain and in extreme temperatures, altitude, and smoke, while maintaining reserve work capacity to meet unforeseen emergencies. A typical fire suppression operation can last several weeks and may involve a constant, 24 hours a day individual exposure to environmental and physical conditions related to the fire and fire suppression operations. These conditions include but are not limited to the following: potential inhalation hazards to smoke, heat stress and exhaustion, and thermal burns from radiant heat from the fires. Lastly, wildland firefighters have died as a result of being overtaken or unexpectedly caught in a fire where escape routes or safety zones are absent, inadequate, or have been compromised.

### **Responsible Parties**

The federal and state governments have the primary responsibility for fighting wildland fires, particularly on state and federal lands. The forces that provide wildland fire protection are usually seen as a separate branch of the fire service and

have a fairly limited relationship to the fire departments that protect most urban and built-up areas, although it is not unusual for urban fire departments to become involved in wildland interface fire fighting operations. Some local fire departments have contractual agreements to provide the initial attack on wildland fires on state or federal lands and participate in the nationwide system for major wildland fires.

### **Safety Measures and Equipment**

Levels of training and performance requirements vary greatly among Federal, state, and municipality wildfire fighting crews. However, a minimum interagency training and qualification standard was developed in 1993 and then revised in January 2000. This standard, *The Wildland and Prescribed Fire Qualification System* (National Wildfire Coordinating Group (NWCG) 2000) was developed and published by the National Wildfire Coordinating Group (NWCG), a multi-agency collective management group made up of representatives of most of the major firefighting organizations. This standard is a performance-based qualification system and prescribes the minimum acceptable level classroom training, in-field training, physical endurance testing, and basic firefighting skills required for wildland firefighters to receive. It also establishes a uniform certification and documentation format for certifying that individuals are qualified to perform in a specific position. Several administrative barriers present are pre-established for wildland firefighting such as the 10 Standard Firefighting Orders and 18 Watch Out Situations (Greeley 1957). These universal wildfire hazard recognition and response statements are common to all wildland firefighters and allow them to safely react to potential

hazardous situations to prevent loss of life (see Appendix C). All firefighting personnel are required to be equipped with proper equipment and clothing in order to mitigate the risk of injury from, or exposure to, hazardous conditions encountered while working. Personal protective equipment (PPE) includes, but is not limited to: 8-inch high-laced leather boots with lug soles, fire shelter, hard hat with chin strap, goggles, ear plugs, aramid shirts and trousers, leather gloves and individual first aid kits. The use of PPE such as fire resistant clothing, hard hats, gloves, neck shrouds, and leather boots are representations of physical barriers. But a physical barrier could include any boundary of thermal protection between the firefighter and the fire itself. A situation where personnel are entrapped by a wildland fire may require personnel to deploy and enter a fire shelter. The fire shelter is a tent-like enclosure constructed from aluminum foil and fiberglass that acts as a barrier by reflecting radiant heat and deflecting superheated gasses away from the individual. A protective clothing and equipment standard for wildland firefighters was established by the National Fire Protection Association (NFPA), a non-profit, international membership organization founded in 1896 to reduce the hazards of fire by developing and advocating scientifically based consensus codes and standards. The “Standard on Protective Clothing and Equipment for Wildland Fire Fighting” or NFPA 1977 (Quincy 1998) offers adequate levels of protection for the wildland firefighter with an initiative to preclude adding undue heat stress or fatigue. In addition to concerns over heat, the standard also is mindful of adding weight as wildland firefighters are required to carry typical loads of 60 pounds of equipment and supplies into a fire zone. This is especially true for smokejumpers, wildland firefighters who parachute into a fire

zone, who must also carry food, water, and shelter. NFPA 1977 states that it does not address respiratory protection.

### **Regulatory and Support Agencies**

While no one agency or organization has jurisdiction over all wildland firefighting efforts, all Federal agencies with wildland firefighting management programs are under auspices of the National Interagency Fire Center (NIFC). The NIFC, headquartered in Boise, Idaho, is a coordination group, support center, information hub, and headquarters for all major wildland firefighting efforts. Seven federal agencies with wildland fire management responsibilities are represented and work together in the NIFC to coordinate and support wildland fire and disaster operations nationwide. These agencies include the Bureau of Indian Affairs, Bureau of Land Management, Forest Service, Fish and Wildlife Service, National Park Service, National Weather Service, and Office of Aircraft Services. The NIFC also has mutual assistance agreements and partnerships with state, local and rural agencies as well as with Canada. All of the federal agencies at NIFC, as well as the National Association of State Foresters and the Federal Emergency Management Agency (specifically the U.S. Fire Administration) are members of the National Wildfire Coordinating Group (NWCG). As first introduced above, the NWCG was created in 1976 by the Secretaries of the Interior and Agriculture to facilitate the development of common practices, standards, and training among the wildland firefighting community. The NWCG has the twelve Working Teams and Advisory Groups that produce detailed products as well as a Wildland Fire Investigation unit formed to

provide some consistency between all agencies in investigation. The Occupational Safety and Health Administration (OSHA) requires employers to provide a workplace free from recognized hazards that are likely to cause death or serious physical harm to employees (the "general duty clause") and to comply with all applicable standards and rules. Employers must be familiar with the standards applicable to their industry; inspect their workplaces for hazards; ensure that employees have safe tools and personal protective equipment; establish and communicate safe operating procedures; provide necessary training; keep records; and more. OSHA does not have any specific industry standards for wildland firefighting but relies on standards created by the NFPA. The National Institute for Occupational Safety and Health (NIOSH) has established the Fire Fighter Fatality Investigation and Prevention Program to include wildland firefighting fatalities. In fiscal year 1998, Congress recognized the need for further efforts to address the continuing national problem of occupational fire fighter fatalities, and funded NIOSH to undertake this effort (NIOSH WebPage 2001). The Congressional language states in part: "In FY 1998, \$2.5 million will be needed to conduct fatality assessment and control evaluation investigations to gather information on factors that may have contributed to traumatic occupational fatalities, identify causal factors common to fire fighters fatalities, provide recommendations for prevention of similar incidents, formulate strategies for effective intervention, and evaluate the effectiveness of those interventions." The overall goal of this program is to better define the magnitude and characteristics of work-related deaths and severe injuries among fire fighters, to develop recommendations for the prevention of these injuries and deaths, and to implement and disseminate prevention efforts. The

National Fire Protection Association (NFPA) as first mentioned above, is an internationally recognized, nonprofit membership organization founded in 1896 to reduce fire and other hazards by developing scientifically based consensus codes and standards, research, training, and education. NFPA codes and standards, which are developed under the approved process of the American National Standards Institute (ANSI), are widely used as a basis of legislation and regulation at all levels of government. The US Fire Administration (USFA/FEMA) programs provide training assistance, educational resources, and advanced education opportunities to local fire departments to include the operation of the National Fire Academy. However, USFA/FEMA does not directly fund, regulate or participate in the delivery of fire services. USFA/FEMA also tracks and reports on the number of firefighter fatalities on an annual analysis focus on specific problems and direct efforts towards finding solutions to reduce the number of future firefighter fatalities. Lastly, the NCWG assigned the Missoula Technology and Development Center (MTDC), a function of the USDA Forestry Service, to be the lead agent for all studies on the effects of wildland smoke on firefighters (Sharkey 1997).

### **Prescribed Fire**

A prescribed fire is defined as any fire ignited by management actions under certain, predetermined conditions to meet specific objectives related to hazardous fuels or habitat improvement. A written, approved prescribed fire plan must exist, and NEPA requirements must be met, prior to ignition. A prescribed wildland fire can also be ignited by natural causes but be allowed to burn to achieve the desired effect within

predetermined boundaries. They are only conducted under certain weather conditions (i.e., during periods of low wind) when flame length and heat can be controlled. Land managers must obtain approval of prescribed fire plans from applicable federal or state agencies before conducting planned burns. In addition, all applicable requirements under the National Environmental Policy Act (NEPA) must be met on federal lands. Before federal land management activities (i.e., trail building, timber harvesting, use of fire, etc.) are conducted, NEPA requires that the environmental impacts of these activities be analyzed to assess their effects on cultural resources, wetlands, soil, water quality, air quality, visibility, and other resources. Effective use of prescribed fire applications increase safety for both firefighters and the public by reducing the amount of organic material available for an uncontrolled wildland fire. Prescribed fires also improve habitat, watersheds, grasslands, and forest ecosystems by reducing the buildup of dead and downed trees, curb insect and disease infestations, and release and recycling nutrients essential for the growth and reproduction of many plant species. As beneficial as prescribed burns are, they are undesirable to nearby residents who object to the smoke created, the potential threat of a fire burning out of control, loss of useful timber, and blackening of local scenery.

### **Health Statistics**

As mentioned above, a considerable amount of attention has been directed at the health and safety of firefighters more recently. The Bureau of Labor Statistics (BLS) maintains labor related statistics on occupational injuries and illnesses. Individual injury and illness statistics about wildland firefighters are not available as they are

included and indistinguishable from urban firefighters (Bureau of Labor Statistics 1999). Also, since most injuries experienced during wildland firefighting are treated at the infield aid stations, most are never documented or reported. The NIFC recognized this deficiency and is calling for the development of a central database system for tracking and reporting injuries and illnesses (Schaenman, Hodges et al. 1998). The National Wildfire Coordinating Group (NWCG) prepares an annual report that contains statistics about wildland firefighter fatalities but doesn't process, analyze, or interpret the data. Several agencies conduct trend analysis on this data to generate recommended changes and action reports (Managan 1999). The USDA/FS report "Wildland Fire Fatalities in the United States, 1990 - 1998" lists that 46 percent of all fatalities were caused by an event called burnover, a situation where wildland firefighters become entrapped by a fire and succumb to its effects (burns/respiratory failure). This report also lists volunteers as the highest group at 31 percent of all fatalities for that period. Heart attacks accounted for 15 percent with accidents and miscellaneous deaths (electrocutions, falls, etc..) accounting for the other 39 percent. The NIOSH's Fire Fighter Fatality Investigation and Prevention Program requires them to investigate and generate a report for each firefighter fatality including those termed wildland. Of the 50 reports generated in 1999 and 2000, only 11 have been for wildland firefighters. Of those 11, only 3 deaths listed "respiratory failure" as the underlying cause (NIOSH WebPage 2001).

## **Respiratory Protection**

Wildland firefighters typically do not wear respiratory protection. Respiratory protection available to structural firefighters such as self-contained breathing apparatus (SCBA) is not practical as its limited air supply, limited refill capacity in the field, and additional weight makes it impractical. Respirators increase in breathing resistance and reduction in metabolic capacity of workers (Weaver 1992). The ideal respirator would be a low resistance, full-face respirator with high visual capacity. The requirement for a high efficiency filter for particulates and filtration for organic vapors increases the level of breathing resistance beyond that which is acceptable to wildland firefighters. In addition, respirators do not filter out carbon monoxide without an exothermic catalytic process that adds additional heat and air resistance to the wearer. Even when a full face, air purifying respirator with carbon monoxide alarm was specifically designed for wildland firefighting by the Lawrence Livermore National Laboratory back in 1992, wildland firefighters rejected it as being ineffective due to the limitations specified above (National Fire Protection Association 1992). Workers instead often wear bandanas and use tactics to limit smoke exposure such as giving up ground to reduce smoke exposures (Sharkey 1997). Workers use training and experience to recognize potentially hazardous smoke situations to avoid them and prevent being exposed. Some health and safety experts recommend conducting real time monitoring for surrogate gasses such as carbon dioxide to allow workers to avoid the potential for overexposures. This will be addressed in Chapter 2.

## **CHAPTER 2**

### **WILDLAND FIRES**

A wildland fire is defined as any non-structure fire that occurs in the wilderness and/or at the urban interface. This term encompasses fires previously called both wildfires and prescribed natural fires. Wildland fires are caused by human activities or by natural phenomena such as lightning or volcanoes. The behavior of wildland fire depends on three elements: fuel, weather, and topography. Each element has several characteristic parameters, which create a complex set of different combinations for wildland fire behavior. The composition of a wildland fire emissions vary with the materials being burned as well as the intensity of the burning process. Wood is typically composed of 50 percent carbon, 6 percent hydrogen, 44 percent oxygen, and a fraction of trace inorganic components such as nitrogen, potassium, magnesium, sulfur to name a few (Tangren, McMahon et al. 1976). Other natural materials consumed in wildland fires such as leaves, grass, organic soils, and such may have slightly more of the trace inorganic materials. Dried leaves, for example, contain up to 2 percent nitrogen, 1.5 percent potassium, and 0.2 percent sulfur. Although there are only a few major chemical elements in wood, the complexity of the burning process results in numerous combinations and results in a large number of chemical compounds being generated. In wildland fires, the two products of complete oxidation are carbon dioxide and water, making up over 90 percent of the mass emitted. The other 10 percent contains the smoke components

that are of major concern such as carbon monoxide, particulate matter, gaseous hydrocarbons, various other organic compounds, and oxides of nitrogen. These inorganic components that occurred in trace amounts in the original state of the organic material now represent a significant percentage of the remaining ash.

### **Burning Process**

Wildland fires occur in three distinct phases of pre-ignition, flaming, and glowing that occur both sequentially and simultaneously in a moving fire front (Tangren, McMahon et al. 1976). More basic is the nature of a fire being a two-stage process of pyrolysis and combustion and often a third stage called pyrosynthesis. Although both pyrolysis and combustion occur simultaneously, the pyrolysis occurs first as it is the initiating stage of chemical decomposition at high temperatures. Pyrolysis is the endothermic reaction that converts large organic molecules into smaller ones. This process separates the organic molecules into char, vapors, high molecular weight hydrocarbons and particulate matter. Combustion is the rapid oxidation of the pyrolysate vapors created by the pyrolysis stage. Combustion occurs rapidly and is exothermic. Depending on which phase the wildland fire is occurring, a third stage called pyrosynthesis may occur. Pyrosynthesis is part of both pyrolysis and combustion and tends to form large, complex organic compounds from smaller free-radical hydrocarbons in high temperature and low oxygen regions of a wildland fire. With pre-ignition phase, pyrolysis is a predominant stage as the organic material is heated and volatile components as well as water vapor (from dehydration) are released. Gasses released typically include carbon monoxide, methane,

formaldehyde, organic acids, methanol, and other highly combustible hydrocarbon molecules. Because the gasses and vapors are hot, they rise and mix with oxygen and ignite leading to the flaming phase. In the flaming phase, the temperature rises rapidly from the heat of combustion. The increase of temperature increases the rate of pyrolysis as well as the generation rate of gas production. The products of the flaming phase are predominately carbon dioxide and water vapor generated as an oxidation byproduct. Some of pyrolysis-generated gasses listed above cool and condense before oxidation or after becoming partially oxidized. Many products of low molecular weight gasses (methane, propane, etc..) remain as gases while high molecular gases cool and condense into small liquid droplets and solid soot particles as they leave the area of combustion. As these condensing substances form, rapidly cooling water vapor condenses with them to produce a visible smoke. The condensing water vapor also reduces combustion efficiency. The high heat of the flaming phase produces a convection column that entrains the smoke emissions. Pyrosynthesis also occurs during the flaming phase as low molecular weight hydrocarbons condense and recombine to synthesize relatively large molecules such as the polynuclear aromatic hydrocarbons (PNAs). The rate of gas generation lessens, as the organic material being burned is nearly ashed. At this point the glowing phase of a fire becomes predominant. This phase is marked by the oxidation of the exposed (solid) surface of the char producing a characteristic glow. This continues as long as temperatures remain high enough and until only a small amount of noncombustible minerals remain as gray ash. If temperatures are not high enough, the char is partially oxidized resulting in a black ash. In a wildland fire, this phase of

a fire occurs after the moving fire front passes. The remaining heat from the glowing phase, the char produces large amounts of smoke in a condition commonly known as smoldering. Without the high temperatures of flaming phase, there is little convective lift from the glowing phase and the emissions are not entrained.

### **Smoke Composition**

The burning of organic matter emits an incredibly large variety of chemical compounds numbering in the thousands. A review of the extensive study of tobacco smoke over the last century provides an illustration (Department of Health and Human Services 1986) of the complexity of smoke characteristics and composition. Tens of thousands of studies have been accomplished identifying over several thousand different chemical compounds. With wildland fire emissions, this list is narrowed down to several hundred of measurable, identifiable chemical compounds divided into three main categories: primary products, secondary products, and particulate matter. As previously mentioned, carbon dioxide and water vapor are the largest amounts of primary products produced and their relative concentrations are indicative of the efficiency of the burning process. As combustion efficiency decreases, the less carbon dioxide and water vapor are produced and the proportion of undesirable emissions increase. These undesirable primary products include carbon monoxide, various hydrocarbons (containing only carbon and hydrogen), various other organics, oxides of nitrogen, and oxides of sulfur. Secondary products such as sulfur oxides and ozone are formed through mixing of primary products such as the interaction of particulate matter and sulfur dioxide. Secondary products are also

formed by photochemical activities such as the formation of ozone in the upper layer of a smoke plume when irradiated with sunlight. Due to the location of generation as far and away from the source of generation, these byproducts become less of an occupational exposure issue and more of an air pollution issue. The third category of chemical compounds, particulate matter, is defined as any dispersed aggregate matter being solid or liquid that for practical purposes is defined as larger than about 0.002 micron in diameter but smaller than 500 microns in diameter. The moisture content of the organic material, the chemical make-up of the organic matter, and the type of fire has a substantial influence on the amount of particulate matter emitted into the atmosphere. Moisture laden organic matter will produce substantially more particulate matter in a flaming fire than would a fire of dry organic matter. The type of fire, such as moving fire front called a heading fire, produces approximately three times more particulate matter than a backing fire (Tangren, McMahon et al. 1976). This is due to organic particles being only partially consumed but entrained by the convective lift of heated air and gasses. Some particles are pyrolyzed but not oxidized or partially oxidized. From the residual heat, these particles continue the oxidation and flaming process producing additional particulate matter in the fire. In addition, the convective lift also entrains additional matter such as soil dust (Sharkey 1997). Other factors such as weather patterns and variations in organic material composition also affect the amount and composition of particulate emissions. Particulate matter, depending on its size and environmental factors, can remain suspended in the atmosphere for several seconds or up to several months. The particulate matter of concern is the fine particulate matter referred to as suspended

inhalable particulate matter. The term inhalable particulates refers to a size of particles that are generally below 2 –3 microns in size, can penetrate deeply into the lungs, have especially long residence times in the atmosphere, and contribute significantly to smog formation and limited visibility.

### **Hazardous Components of Smoke**

Studies of the composition of smoke that wildland firefighters are potentially exposed to have identified literally hundreds of compounds but most in very minute concentrations. Of the studies conducted, the list of compounds is often divided into approximately 9 categories (Ward 1997). These categories are Particulate Matter, Polynuclear Aromatic Hydrocarbons (PAHs), Carbon Monoxide, Aldehydes, Organic Acids, Semivolatile and Volatile Organic Compounds, Free Radicals, Ozone, and Inorganic Fraction of Particles. The health hazard effects of exposure to wildland fire smoke are often delineated in studies by the acute and chronic effects.

### **Acute Exposures**

For acute exposures to wildland fire smoke, this list of compounds is narrowed down to four items of interest that have been shown to be present at appreciable levels of concern (Sharkey 1997). These items are carbon monoxide, inhalable particulate matter, formaldehyde, and acrolein (acrylaldehyde). Other irritants such as organic acids, phenolic compounds, nitrogen oxides, and benzene have appeared in several studies of wildland fire smoke but are not present in wildland fire smoke of appreciable concentrations of concern. A limited number of studies of the acute

inhalation hazards to wildland firefighters indicate that there is a potential for hazardous exposures to these four acutely toxic gasses (Quincy 1998). These studies of the respiratory effects of smoke inhalation to wildland firefighters indicate that exposure can cause acute respiratory irritation (coughing, sore throats, temporary reduction in lung function) and eye irritation (Sharkey 1997). Carbon monoxide concentrations can exceed concentrations of 100 – 200 parts per million immediately at the fireline. These concentrations are quickly dispelled by normal atmospheric dilution processes to concentrations below 10 parts per million (ppm) for short-term exposures near the fire line. Carbon monoxide is also produced in lesser but significant concentrations during backing or smoldering fires when the combustion process is inefficient. The presence of carbon monoxide in the blood stream reduces capacity of blood to transport oxygen causing disorientation or fatigue in firefighters. Inhalable particulate matter represents a significant irritant as particle concentrations on fire lines often exceed the 8 hour Permissible Exposure Limit (PEL) for respirable particulate matter exposures of 5 milligrams per cubic meter ( $\text{mg}/\text{m}^3$ ) for nuisance dusts. This exposure limit only considers the irritating affects from inert dusts (mineral, inorganic, and organic) and not the potentially active chemicals that often attach to the carbon particulates. Exposures at or above this level can produce serious effects for mucous membrane irritation (upper respiratory and eye irritation) as well as penetrate deeper into the lungs reducing lung capacity, congestion, and persistent coughing. Another major contributor of mucous membrane irritation in smoke are aldehydes such as acrolein and formaldehyde that are more effective irritants due to their low molecular weights and higher solubility. Their toxicity is enhanced by the

presence of sorptive respirable particulate matter that can transport them deeper into the respiratory system than they normally could penetrate. Acrolein concentrations could be as high as 0.1 to 10 ppm at or near the fireline and is a significant contributor to the irritant nature of smoke (Ward 1997). Organic gasses like benzene can also be transported by inert sorptive respirable particulate matter deeper into the respiratory system, causing a more toxic effect. As potent as these effects are, they have been shown to be mostly transitory and reversible cases.

### **Chronic Exposures**

Surprisingly, little is known about the long-term exposure to wildland fire smoke despite the presence of several potent carcinogenic compounds present in wildland fire smoke (Sharkey 1997). The aromatic compounds identified in wildland fire smoke are broken into esters, phenols, and polycyclic organic matter (POM). The three chemical compounds that commonly appear in the limited research conducted on chronic effects are benzene, formaldehyde, and benzo(a)pyrene (a POM). While they are not present at appreciable levels, they are of high concern because they are recognized as potent carcinogens. Using cigarette smoking as a model for exposure indicates that wildland firefighters have the potential for coronary heart disease and stroke, chronic obstructive pulmonary disease, and cancer. Case-control studies have had little validity as the potential exposure to other hazards (e.g., smoking, radon, wood burning, air pollution) confounds the data. A prospective study of the health effects may be the best way to study the long-term effects to wildland fire smoke exposures. Some studies suggest that the loss of lung capacity may have an

accumulative effect over a lifetime (Cone 1990). Most studies and agency reports list the need for additional studies on the chronic effects.

### **Exposure Assessments**

The studies conducted for wildland firefighter smoke exposures indicate that for those who were studied, fewer than 5 – 10 percent were exposed to concentrations that exceeded the established Permissible Exposure Level (PEL) for these 5 compounds (Sharkey 1997). Overall, studies have shown that time weighted average (TWA) worker exposures were consistently below PELs for these compounds (Table 1).

Table 1  
*Typical 8-hr Exposure Concentrations to Wildfire Smoke*

Hazardous Component	WL TWA	Rx TWA	OSHA PEL
Carbon Monoxide (ppm)	4.1	4.1	50
RPM (mg/m <sup>3</sup> )	0.69	0.63	5.0
Formaldehyde (ppm)	0.023	0.047	0.75
Acrolein (ppm)	0.003	0.009	0.1
Benzene (ppm)	0.016	0.016	1.0

*Note:* From *Understanding the Health Hazards of Smoke*, by B Sharkey, 1999, Missoula, MT: USDA Forest Service Technology and Development Program

### **Size Distribution of Particulate Matter**

The size distribution of particulate matter from smoke is a log-normally distributed.

As indicated above, the type of fire is the main factor affecting the amount of particulate matter emitted into the air. It also affects the size distribution as well.

Smoldering combustion releases several times more fine particles than flaming combustion (Ward 1997). Distance from source also affects size distribution as larger sized particles settle out more quickly than smaller sized particles. Studies of the size distribution of smoke near the fire indicate that the mass mean diameter of the distribution typically ranges from 0.1 to 0.3 microns. A composite of several

distributions are represented in figure 2 for mass and number distribution (Tangren, McMahon et al. 1976). These figures indicate that the mass distribution of smoke particles differs greatly from the number distribution. While a majority (>99 percent) of the smoke particles are smaller than 0.4 microns, only about 63 percent of the mass of smoke particles are smaller than 0.4 microns, only about 63 percent of the mass of particulate matter has a diameter less than 0.4 microns.

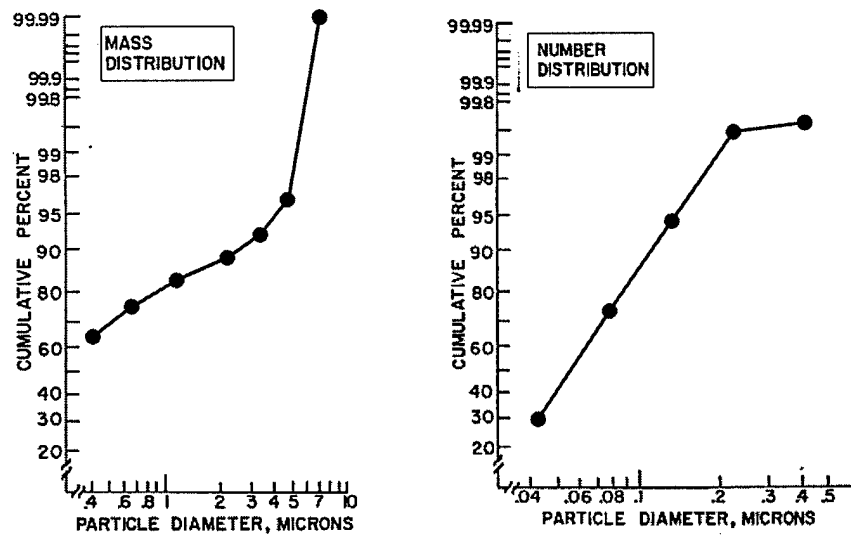

Figure 1. Typical Mass and Number Distributions of Smoke Particles. Data from *Contents and Effects of Forrest Fire Smoke*, 1976, C. D. Tangren, Macon, USDA Forestry Service

These two distributions are important to note as some of the physical properties of smoke particles more closely related to the mass distribution and others to the number distribution. With light scattering properties, the particles having diameters within the wavelength of visible light, or 0.3 to 0.8 microns, cause maximum amount of scattering.

### ***Correlation Analysis***

Studies conducted of the toxic compounds in wildland fire smoke have indicated a linear correlation exists between carbon monoxide, respirable particulate matter, and

irritant gas concentrations (Reinhardt, Ottmar et al. 1999). These studies conclude that while concentrations vary with the type of fire (flaming versus smoldering), the upper level concentrations increase in a linear fashion. This allows for a surrogate gas to be monitored providing reasonably accurate exposure modeling evaluations to the contaminants listed in Figure 3 (Reinhardt and Ottmar 2000) with a coefficient of correlation ( $R^2$  value) ranging from 0.68 to 0.79 (1 indicating a strong relationship, 0 indicating no relationship).

<u>Carbon Monoxide Formulas</u>	
Formaldehyde (ppm)	[HCHO] = 0.003598 X [CO] + 0.004
Acrolein (ppm)	[ACRO] = 0.00042 X [CO] + 0.003
Respirable PM (mg/m <sup>3</sup> )	[RPM] = 0.0498 X [CO] + 0.80

Figure 2. Exposure concentration formulas using carbon monoxide. From *Smoke Exposures at Western Wildfires*, 2000, Portland, OR: USDA Forest Service

The formulas allow for the combined irritant effects of these contaminants to be added together into an irritant exposure index as seen in figure 3. Using this formula,

<u>Irritant Exposure Index Formula</u>		
$E_m =$	$\frac{[\text{HCHO in ppm}]}{\text{Formaldehyde TLV}}$	$+$
	$\frac{[\text{ACRO in ppm}]}{\text{Acrolein TLV}}$	$+$
	$\frac{[\text{RPM in mg/m}^3]}{\text{Respirable PM TLV}}$	

Figure 3. Irritant Index Exposure Formula. From *Smoke Exposures at Western Wildfires*, 2000, Portland, OR: USDA Forest Service

workers would be protected from acute irritation to smoke exposure if they maintained and exposure index below 1. Initially, these formulas were derived to help alert workers of potential inhalation hazards using personal CO exposure monitoring. However, in more recent studies, these calculations have been refined to

allow them to be used to conduct detailed exposure assessments using only CO monitoring. This may be due in part to workers primarily not using CO monitors due to the high cost (\$900 – \$1200) per monitor (Sharkey 1997). Using the formulas in Figures 2 and 3 and the most current ACGIH TLVs for the chemicals listed, in order to prevent acute irritation to smoke exposure (maintaining the equivalent exposure irritant index below 1), workers exposure to carbon monoxide must be maintained below a time weighted average level of 21 ppm. Extrapolating from this, if worker exposure to respirable particulate matter was maintained below a time weighted average level of 1.85 mg/m<sup>3</sup>, most workers will not experience the acute effects of smoke exposure. These studies have shown a correlation using best – fit linear regression and that some irritant exposures would be above as well as below the regression line. In addition, there may on occasion be other irritant gasses present that are not accounted for in the equations. The latest study also suggested using worker visual assessment of smoke conditions using a classification system developed during the study (Reinhardt and Ottmar 2000). The correlation between worker assessments varied considerably due to the subjectivity of workers. The study suggests that better worker training and education is required to reduce this variability.

## CHAPTER 3

### SMOKE DETECTOR TECHNOLOGY

There are a wide variety of smoke detector technologies produced and available commercially. Photoelectric (also known as light-scattering), ionization, and heat sensitive are commonly technologies used in the design of and construction of common household smoke detectors. As a result of the mass production, the unit cost per detector is made affordable. Less common technologies such as infrared optical absorption are available but at a substantially higher per unit cost making it cost prohibitive for utilization as an individually issued and disposable monitor. Of the three technologies commonly available, the use of heat detection is inconsistent with the goal of monitoring the atmosphere for potential inhalation hazards and is ineffective for this goal. Both ionization and photoelectric technologies are based on atmospheric condition monitoring and are examined in detail for applicability.

#### **Ionization Detector Technology**

Ionization type smoke detectors are sensitive to relatively small particles (Mulholland and Bukowski 1986) with diameters less than 0.3 micrometers ( $\mu\text{m}$ ). The detector contains a miniscule amount of a radioactive material called Americium 241 (Am 241). Am 241, atomic number 95 and atomic mass of 241, is widely used due to its low energy alpha particles, its long half life of 457.7 years, and its relative abundance and low cost (Litton and Hertzberg 1977). The Americium is maintained in solid

form and enclosed by a metallic coating to prevent oxidation and reduce the mean range of the Am 241 alpha particles below 4 centimeters in dry air at 15 degrees Celsius and 1 atmosphere pressure. The Am 241 emits an alpha particle with a small amount of gamma radiation with the primary emission of concern being the alpha particle. The alpha particles pass through the air and through inelastic collisions they create equal numbers of positive ions and electrons (which rapidly attach to neutral molecules forming negative ions). This creation of equal numbers of ion pairs creates

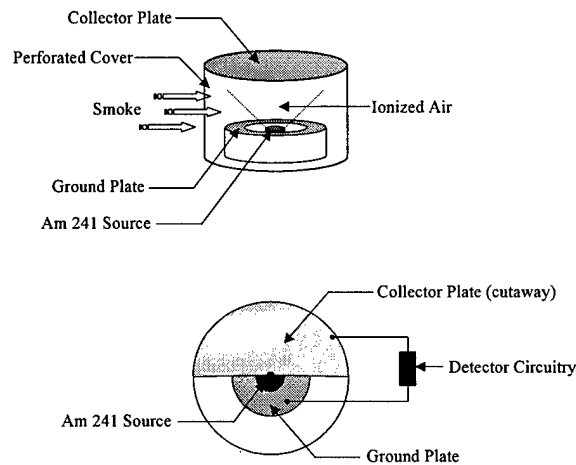

*Figure 4.* Ionization Smoke Detector Diagram

a conductive path by which a current can be applied from a ground plate to a collector plate (see figure 4). If the composition of the air between the collector and ground plates remains relatively unchanged, the current will remain steady state. As smoke enters the chamber of ionized air, the larger smoke particulate matter absorbs the emitted alpha particles and reduce the flow of the current. This minute drop of current is detected by the monitoring circuitry, which is composed of integrated circuits on a microchip that uses signal processing to reduce false alarms and assure accurate responses. If the current falls below the preset sensitivity of the detection circuitry, it triggers the alarm. The detector circuitry incorporates a variety of logic

subroutines to accurately monitor for sustained current fluctuations. The Am 241 is regulated by the Nuclear Regulatory Commission (NRC), which issues licenses for the manufacturing of smoke detectors. After manufacture, the smoke detector itself is exempted from licensing, control, and disposal by the fire prevention provisions of 10 Code of Federal Regulations (CFR). The size selection nature of this type of detector is reflected by nearly every manufacturer of ionization smoke alarms. Their literature infers that this type of technology is generally more effective at detecting flaming fires that consume combustible materials rapidly, spread quickly, and produce large numbers of finely sized particulates. This is observed by the accidental alarm of an ionization detector that is placed in a kitchen and activates as a result of cooking fumes present in the air.

### **Photoelectric Detector Technology**

Photoelectric type smoke detectors employ a simple principle of the detection of (light) photons scattered by smoke particles in the sensing chamber. In modern photoelectric smoke detectors, a light emitting diode (LED) operating in the near infrared range is used to create the photons of light (Mulholland and Bukowski 1986). Commercial household smoke detectors employ both gallium arsenic (GaAs) and gallium-aluminum-arsenic (GaAlAs) semiconductor material in generating a near infrared beam with a spectral peak of 880 nanometers (nm) and a spectral width of 50 nm. The near infrared wavelength was selected over white light, as it is less sensitive to interferences from air and gasses. The LEDs are operated in pulsed mode with a pulse duration of 100 microseconds, current of 0.3 amps, with a typical pulse

repetition frequency of 1 cycle per second. The use of short, intense pulses produce a good signal to noise ratio without overheating the LED emitter. The beam is

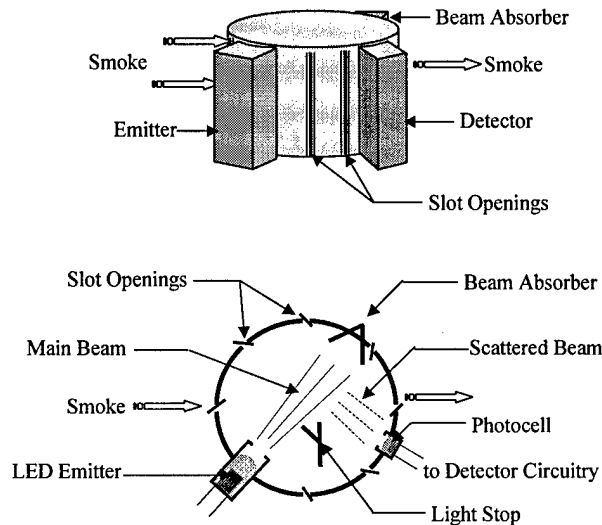

Figure 5. Photoelectric Smoke Detector Diagram

directed at an absorbent material that prevents any reflection of the incident beam. A silicon-based, photoconductive detector is placed adjacent to the emitter at an angle that excludes emitted photons from striking the detector directly. A light stop is also added between the emitter and detector to prevent incidental photons from striking the detector. Smoke particles enter the sensing chamber through the slots on the sides of the sensing chamber. These slots are angled to allow the passage of smoke particles but prevent the entrance of photons from outside light sources and accidental alarms. The large smoke particles that enter the sensing chamber interfere with the near infrared beam by scattering some of the energy. Some of the scattered photons are scattered over a certain angular range that allows them to strike the detector. The detector has a lens placed on it to focus the scattered photons onto the active surface of the photocell. The incidental energy photons change the resistance of the detector.

A monitoring circuit, usually a series of integrated circuits, applies a voltage to the photocell and monitors the current. When the current increases above a preset sensitivity level, the alarm is triggered. Photoelectric detectors are sensitive to relatively larger particles (Mulholland and Bukowski 1986) with diameters greater than 0.3 micrometers ( $\mu\text{m}$ ). Due to this size-selective process, photoelectric type smoke detector manufactures' literature suggest that they are more suitable for use in kitchens to prevent false alarms from cooking fumes.

### **Sensitivity Settings**

Sensitivity level, also called the alarm point in some manufacturer's literature, is the minimal level set by the manufacturer to assure accurate responses to potentially hazardous atmospheres with minimal false alarms. The sensitivity level set to meet the specific standards set by Underwriters Laboratory, an independent certification laboratory for safety certification of consumer products. The standard specific for smoke detectors is UL 217 which details specific product response requirements to meet the NFPA standard for all smoke alarms, NFPA 72 "National Fire Alarm Code". According to UL 217, the testing laboratory procedure produces smoke, by cotton wick, within a smoke box while measuring the smoke profile using both a photocell and a measuring ionization chamber. The photocell produces a light beam, which the units are represented in micro-amps. The measuring ionization chamber (MIC) values are denoted in pico-amperes. Once the smoke detector produces an alarm signal, both values, beam and MIC, are recorded. The standard has a correlation table within it that converts the light beam from the photocell into percent per foot

obscuration (acceptable range is 0.5 to 4.0 percent per foot obscuration). UL 217 specifies different equations that allow for the calculation at any distance the percent per foot obscuration, the percent obscuration of light for the full-length beam at any distance, the total optical density at any distance, and at any distance, the optical density per foot (Tamas 2001). As sensitivity levels are set at specific level standards set by Underwriters Laboratory, no smoke alarm has an adjustable sensitivity level.

### **Limitations and Interferences**

Smoke alarms are sensitive devices that are made to respond to small concentrations of combustion (smoke) particles. However, since smoke alarms do respond to particles in the air, they are susceptible to activating when encountering particles in the air other than smoke. As discussed in Chapter 2, a rapidly burning, flaming type of fire will entrain soil dusts and potentially increase personnel exposures to airborne particulate matter. Therefore, this non-differentiating type of monitoring is beneficial when monitoring wildland firefighter exposures. Typically, a build up of dust or debris inside a smoke detector will eventually cause a false alarm if not cleaned regularly. A jet of air or cleaning it with a powerful vacuum cleaner can reduce dust build up and false alarms. Also, due to the low per unit cost, a malfunctioning monitor can be discarded and easily replaced. Smoke alarm manufactures report that the operational range for exposure to humidity is 10% - 93% relative humidity. Common household smoke alarms are typically not certified to be intrinsically safe.

### **Applying the Technologies**

As stated in chapter 2, some of the physical properties of smoke particles more closely related to the mass distribution and others to the number distribution. With light scattering properties, the particles having diameters within the wavelength of visible light, or 0.3 to 0.8 microns, cause maximum amount of scattering. As described above, this effect is represented by the operation of the photoelectric smoke detectors. The size distributions in Figure 1 indicate that nearly 66 percent of the mass of particulate matter has a *mass* mean diameter greater than 0.3 microns. Therefore, the utilization of photoelectric detector technology should be very effective in monitoring wildland fire air concentrations. Similarly, the physical property of the absorption of alpha particles by smoke particles is more closely related to the number distribution than mass distribution (Litton and Hertzberg 1977). The size distributions in Figure 1 indicate that over 99 percent of the number of particulate matter has a diameter less than 0.3 microns. Therefore, the utilization of ionization detector technology should also be very effective in monitoring wildland fire air concentrations.

### **Advantages of Using Smoke Detectors**

Photoelectric and ionization smoke alarms are both effective in sensing smoke particles. As they are mass marketed, the individual costs range from a few dollars to fewer than thirty dollars. Other features include a low battery warning as well as a false alarm control feature. When the battery in most smoke alarm requires replacement, the smoke alarms will sound a short beep approximately once every

minute. Most smoke alarms have a false alarm control feature that will temporarily lower the sensitivity of the smoke alarm to quite an unwanted alarm. If a false alarm sounds, the test button may be pressed to cease the sounding alarm. The smoke alarm will automatically return to full sensitivity in a set time (usually 5 - 15 minutes). Upon returning to full sensitivity, most smoke alarms will signal their status using a series of beeps.

### **Prototype**

In utilizing smoke detectors as a monitoring device of potential smoke inhalation conditions, the sensitivity settings of the proposed monitors should be set to a desired particle concentration. As discussed in Chapter 2, the proposed particle concentration to prevent exposures to irritant gasses and particles was  $1.85 \text{ mg/m}^3$ . Below this concentration, most workers will not experience the acute effects of smoke exposure. Above this concentration, the alarm would sound and alert workers to take measures to avoid potential inhalation hazards. A manufacturer can adjust sensitivity by altering the properties of the circuits inside the microprocessor. In addition, sensitivity can be altered in a photoelectric detector by altering the scattering angle or by using shorter, more intense LED pulses (Mulholland and Bukowski 1986). Sensitivity can be altered in ionization detectors by replacing the collector and ground plates with concentric cylinders (Litton and Hertzberg 1977) to create a more sensitive uni-polar detection region. Lastly, smoke alarms produce noise levels in excess of 85 decibels A-weighted (dBA) at a distance of 5 – 10 feet. At distances closer than this, a sounding alarm may represent a hazardous noise source and

possibly a disruption to normal communication. Clearly the alarm noise level would be reduced to a safer, more effective level.

## **CHAPTER 4:**

### **TESTING OBJECTIVES**

In order to apply smoke detector technology to monitoring air for inhalation hazards, the detectors required tested for accuracy and precision in adequately responding to controlled set of smoke conditions. In addition, testing was required to determine which type of detector (ionization or photoelectric) worked best in the objective application. Measuring the level of response of each type of detector to identical smoke conditions was determined to be the best method to test this. Variables not previously accounted for also required examination and testing when necessary. Lastly, related issues of use, functionality, and applicability was examined. All testing procedures used are provided in Appendix A.

#### **Testing Chamber**

In order to adequately evaluate the detectors under controlled smoke conditions, the smoke test chamber was designed, constructed, and tested. The design and construction of the test chamber allowed for the even flow of smoke to be distributed among the smoke detectors. The design in figure 6 allowed for this. The smoke-generating chamber located on top of the chamber has an inlet to draw air through one or two lit cigarettes. Circulating fans located on the inside of the smoke-generating chamber stirred the smoke and ensured the smoke particles were evenly distributed. Some of the larger aggregate was removed from the stream due to the

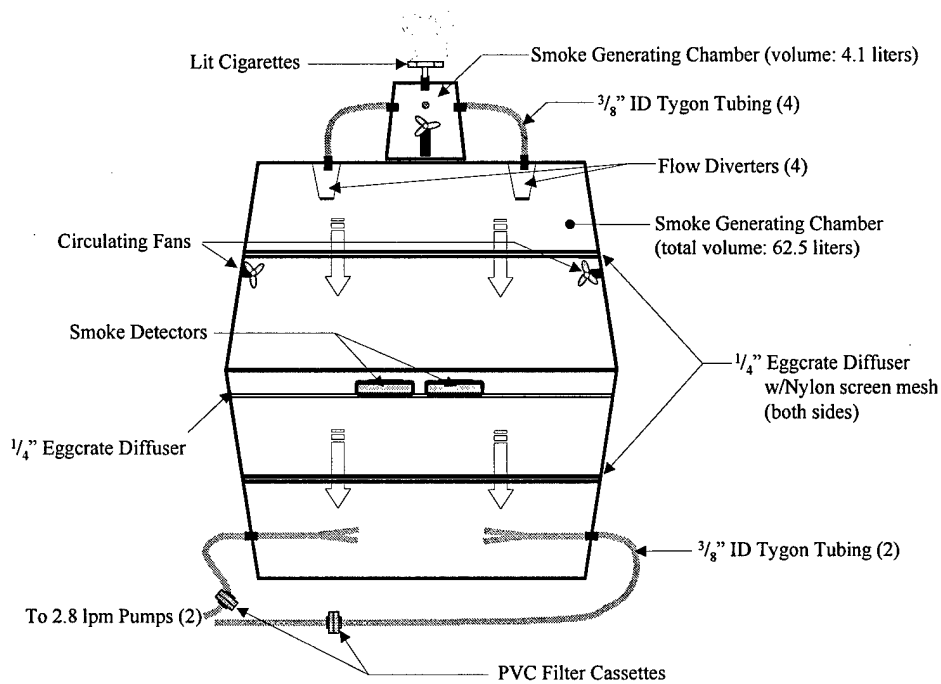

Figure 6. Test Chamber Design Diagram

velocity forcing the particles to strike the walls. However, this loss was minimal and acceptable as this condition was consistent for all experiments. The flow of smoke was then diverted through four inlets into the test chamber. The flow was prevented from jetting by diverters that redirected the flow. The two egg-crate diffusers (on top and bottom of chamber) have nylon mesh screens on both sides to restrict and redistribute the airflow evenly. The smoke detectors were placed on top of a third egg-crate diffuser that does not have nylon screening on it. The smoke chamber was tested by sealing the chamber, activating the pumps and fans, initiating a smoke generating cycle, and observing the flow of smoke. The goal was to ensure the flow of smoke was equally distributed to each of the smoke detectors.

### Accuracy and Precision

As previously stated, smoke detectors are certified using UL and NFPA requirements through independent laboratory testing. This level of smoke sensitivity for smoke

detectors is based on a response that accurately reports the presence of smoke while minimizing the number of false alarms in a household environment. It is not indicative if the technology is capable of accuracy and reproducibility that would be required function of a personal warning device. As previously introduced, particulate matter concentrations increase with the concentrations of the respiratory irritants. Smoke detector sensitivity levels must be able to accurately respond to a preset particulate matter threshold concentration with acceptable precision in order to safely warn the wearer of a potential health hazard. Activation when no clear hazard is present leads to worker mistrust and non-use. Inactivation during periods of hazardous atmospheres may lead to an overexposure and possible adverse health conditions.

### **Detector Accuracy and Precision Testing**

The accuracy and precision (reproducibility) testing of both types of detector technology was accomplished in a chamber in which the concentrations of the smoke were controlled. Cigarette smoke was used as this allowed for the generation of a somewhat consistent smoke composition. Inside the chamber a total of 5 of each type

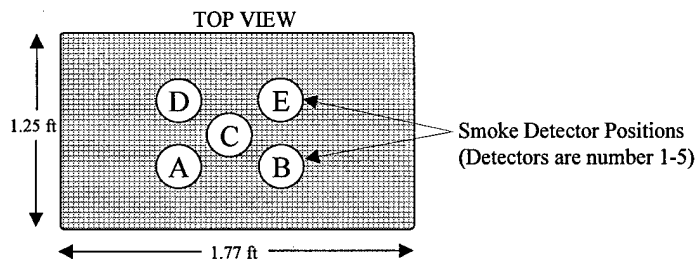

*Figure 7. Top View of Detector Test Area*

of detector were placed to perform the test as depicted in figure 7. This number represented the maximum number that could be simultaneously tested under controlled, similar conditions inside the chamber. The detectors were placed in random positions inside the test chamber for each test cycle. Each cycle allowed for the determination of inter-group variability (homogeneity) by comparing individual response times. The test cycle was repeated 5 times for each type of detector. By comparing the response times of each position, the bias related to positioning was observed and corrected for. For each cycle, a poly vinyl chloride (PVC) filter was used to collect smoke particles to ensure that similar conditions were maintained (quality assurance) by comparing concentrations as well as an indication of the concentration thresholds required to activate the detectors. The response times of each type of detector were averaged and compared for determining which type of detector technology provides a more consistent response. The concentration of smoke inside the chamber increased exponentially (see figure 8). When all of the detectors activated, the generation of smoke was ceased and the individual activation times recorded. The air drawn through the chamber was filtered to determine the activation concentration. This sampling included a period of time after the smoke generation was ceased so that a significant proportion of the smoke (90%) that was inside the chamber could be collected. Both types of detectors were tested in this fashion. The response times as well as the concentrations measured were compared to identify if either detector is more responsive to the type and concentration of smoke generated. The positions of the detectors were marked (see figure 7) to allow for the testing of positioning-bias associated with activation times of the detectors.

## Testing Calculations

Total smoke concentration inside the chamber increased exponentially as depicted by Phase I in figures 8 and 9. When all 5 of the detectors activated, the smoke generation was ceased and the concentration decreased exponentially as depicted by

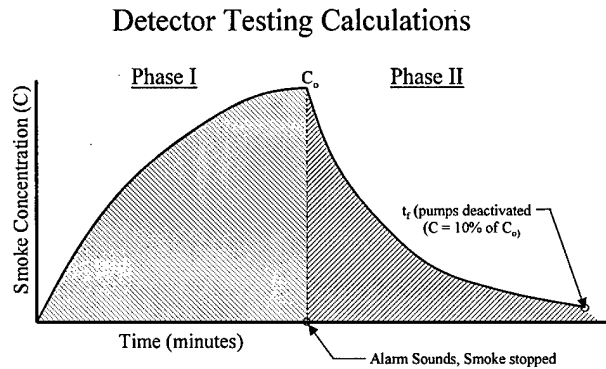

Figure 8. Test Chamber Smoke Concentration Plot

Phase II in figures 8 and 9. For a set flow rate ( $Q$ ) of 5.6 liters per minute (lpm) and total internal volume of ( $V$ ) of 130.7 liters, the time required to obtain at least

<p><b>Phase I</b></p> $C = \frac{G}{Q} (1 - e^{-\frac{Qt}{V}})$ <p><math>C</math> and <math>G</math> are unknowns, <math>t</math> is the time the detectors sound at which the smoke will no longer be generated (<math>G</math> becomes 0) and <math>C = C_o</math> (also unknown)</p> <p><b>Phase II</b></p> $C = C_o e^{-\frac{Qt}{V}}$ <p><math>C</math> and <math>C_o</math> are unknowns; to determine <math>t_f</math>, use point at which <math>C</math> is 10% of <math>C_o</math></p> $\frac{C}{C_o} = 0.10 = e^{-\frac{Qt}{V}} \implies t_f = \frac{2.3 V}{Q} = 53.6 \text{ minutes}$	<p><math>C</math> = smoke concentration</p> <p><math>C_o</math> = maximum smoke concentration</p> <p><math>G</math> = Generation rate</p> <p><math>t</math> = elapsed time (minutes)</p> <p><math>V</math> = volume (130.7 liters)</p> <p><math>Q</math> = volumetric flow rate (5.6 lpm)</p>
--	---

Figure 9. Concentration Formulas and Calculations

90% of the maximum smoke concentration was approximately 54 minutes (see figure 9). The velocity of the smoke at the smoke detector was obtained from dividing the

total flow rate (Q) by the area (A) of the diffuser that the smoke detectors are placed upon as depicted in figure 8. As this flow rate was insufficient to activate the alarms, the use of two small circulating fans were added to increase the air flow across the

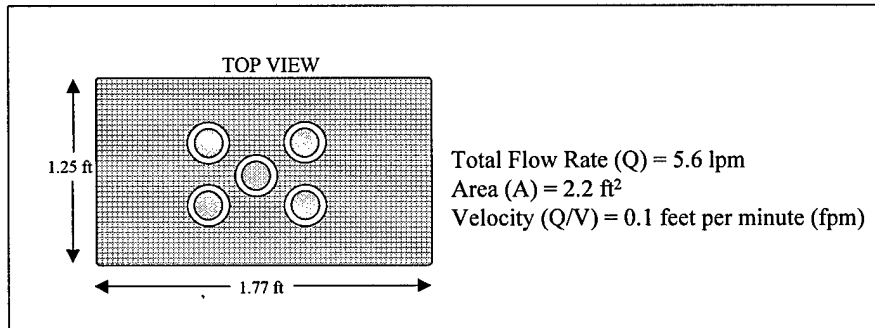

smoke detectors and increase mixing. While this air velocity rate was unknown, the validity of the results was unaffected as the flow rate was consistent throughout the experiments.

### Air Velocity Testing

By adapting the test chamber with a device to rotate the detectors, the relationship between detection (response) time and air velocity was determined. A device similar to the one depicted in figure 9 with variable rotational speeds was developed to

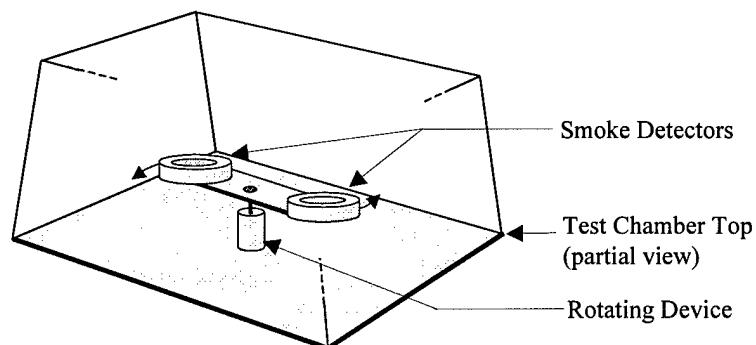

Figure 11. Chamber for Air Velocity Testing

test this relationship. The circulating fans inside the main chamber were removed and the introduction of smoke into the chamber was conducted under identical, repeatable conditions for each test performed.

### Velocity Testing Calculations

The air velocity that the detectors were exposed to was calculated by measuring the radius (r) from the sensor to the center of rotation to calculating the circumference as in Figure 12. The rate of rotation (rotations per minute or rpm) was measured for at

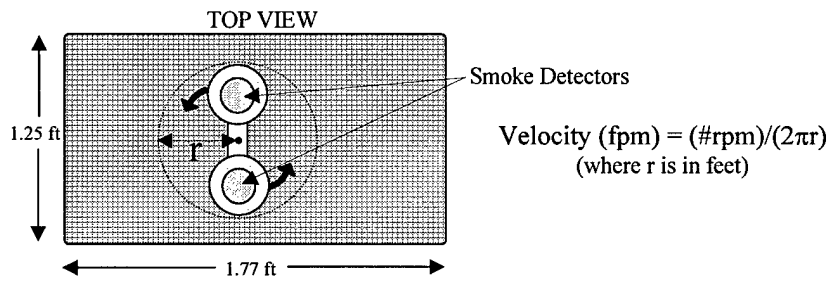

Figure 12. Top View of Air Velocity Testing Platform

least 10 rotations to obtain an average rpm. The velocity was calculated by dividing the rpm by the circumference. The tests were conducted for a wide range of air velocities to allow the air velocity – detector response time relationship to be plotted. With the exceptions noted above, the testing cycle followed the Detector Accuracy and Precision Testing as previously detailed. The activation concentrations were determined for each testing cycle to ensure the results were comparable.

### **Reliability Issues**

The detector components required examination to determine if they are rugged enough to survive rough handling from being worn by the user. Observations were made of the detector sensors to determine if film build-up from smoke did substantially occur inside the smoke detectors to degrade performance.

### **Other Issues**

Other questions that required addressing were whether the workers would actually use them (wear, activate, heed the warnings). The best way to gauge would have been to test a prototype in the field during a controlled fire and then to query wildland firefighters of their opinions, observations, and recommendations using a questionnaire.

## CHAPTER 5

### RESULTS AND DISCUSSION

The purpose of this study was to determine if the existing smoke detector technology could be adapted to serve as an inexpensive warning device for wildland firefighters of a possible inhalation hazard and to avoid the need for respiratory protection. The two common types of technology, ionization and photoelectric, were tested and evaluated for accuracy and precision as well as other conditions that may impact overall functionality for the proposed application.

#### **Smoke Chamber Testing Results**

Before the detectors could be tested, the testing chamber itself was tested to ensure it adequately created an environment with consistent, evenly dispersed smoke with a controlled flow rate. The early results indicated that diverters were needed to prevent jetting of the smoke into the testing compartment. Later, circulating fans were required to create air movement across the smoke detectors as the detectors failed to respond to even extreme smoke concentrations. After these modifications, the chamber operated satisfactorily producing well dispersed smoke concentrations and causing adequate detector activations for both low and high flows rates. The most frequent problem encountered was ensuring that an adequate seal was achieved prior to each cycle. This was best addressed by modifying the test procedure by including an initial negative pressure check for each cycle.

## Accuracy and Precision Testing Results and Conclusions

The accuracy and precision testing indicated both types of detectors have low inter-group variability and both type of detectors responded accurately with precision as

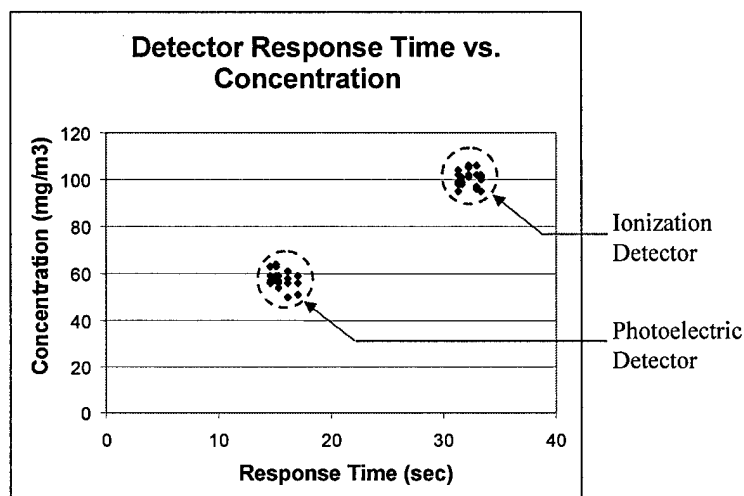

Figure 13. Graph of Detector Accuracy and Precision Testing. Data from Tables 3 - 6.

seen in Figure 13. For the controlled conditions in the testing chamber, the mean response times for the photoelectric type detectors ranged from 55 to 60 seconds with standard deviations that ranged from 1.8 to 4.1 seconds (see Table 3). The average mean response time was 57 seconds with a standard deviation of 2.1 seconds. The mean activation concentration, measured to assure similar test conditions were maintained, ranged from 14.7 to 17.1 mg/m<sup>3</sup> with a mean of 15.7 mg/m<sup>3</sup> and a standard deviation of 1.0 mg/m<sup>3</sup> (see Table 4). Similarly, for the ionization type detector, the mean response times ranged from 100 to 104 seconds with standard deviations that ranged from 1.4 to 4.1 seconds (see Table 5). The average mean response time was 101 seconds with a standard deviation of 1.9 seconds. The mean activation concentration ranged from 31.3 to 33.3 mg/m<sup>3</sup> with a mean of 32.3 mg/m<sup>3</sup> and a standard deviation of 0.8 mg/m<sup>3</sup> (see Table 6). The results of the response

times, when examined by positioning, indicated some minor bias in photoelectric detector placement inside the test chamber as the positional bias varied from 1.0 to 4.4 seconds. For the ionization detectors, this placement bias was less pronounced as the positional bias varied from 2.5 to 4.9 seconds. The coefficient of variation (standard deviation divided by the mean) varied from 3.2 to 7.2 percent for the photoelectric detectors and 1.4 to 4.1 percent for the ionization detectors, indicating the overall error was minimal and the response times measured had acceptable accuracy and precision. An interesting observation is that the photoelectric detectors responded quicker and with smaller activation concentrations than the ionization detectors despite the fact that the majority (>99 percent) of the smoke particles are smaller than 0.4 microns, ideal conditions for ionization detector response as explained in previous chapters. Initially, this was explained as nearly 63 percent of the mass of particulate matter in smoke has a diameter less than 0.4 microns, indicating a considerable portion with a diameter within the wavelength of light and causing high amounts of light scattering. However, as a result of the air velocity test below, the true cause of this observation was determined.

#### **Air Velocity Testing Results for Photoelectric Detectors**

One of the unexpected results of the accuracy and precision testing (above) was the interdependency of photoelectric detector response times with air velocity across the detector's sensor. Previously unrealized, the operation of a standard photoelectric smoke detector is based on the typical, normal airflow inside a home. This activation air velocity is estimated to be approximately 40 feet per minute using the typical air

velocity values in Table 2. This activation air velocity much higher than the airflow of the smoke stream created inside the test chamber of 0.1 fpm (from Figure 10) and far below the airflow expected in an outdoor environment of approximately 300 feet per minute (Burton 1988).

Table 2  
*Typical Air Velocity Values*

Velocity (fpm)	Location
3	Settling velocity of heavy suspended particles
40	Random air movements inside a structure
100	Human sensitivity limit of detectable air movement (due to pressure), moisture on skin will increase sensitivity
300	Typical Eddy velocities from walking, wake created near body
700	Average wind velocities of approximately 8 miles per hour

Note: from *Simple Rules-of-Thumb for Use in Industrial Ventilation* (pg 40), by D. Jeff Burton, November 1988, Waco, TX: Occupational Health and Safety Journal

Therefore, the relationship of air velocity to the sensitivity (activation times and activation concentrations) must be determined for each type of detector. As outlined in the Air Velocity Measurements section in Chapter 4, two photoelectric type detectors were rotated inside the test chamber while a smoke stream was initiated. The rotational speeds were varied and the response times were recorded for each

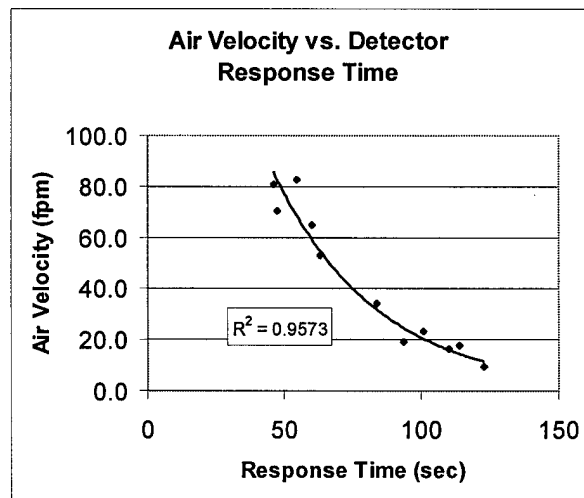

velocity. Initially, the response times for velocities was measured and found to be exponentially related as demonstrated in Figure 14. The correlation ( $R^2$ ) value of approximately 0.96 indicated a tight fitting exponential curve was achieved. However, as the expected operational range of the detector was near 300 fpm, the tests would be repeated for a much higher speed. The rotational speed was adjusted to the maximum by maximizing the voltage to the motor as well as increasing the turning radius to its maximum while ensuring clearance between the rotating detectors and the sides of the testing chamber. The maximum speed achievable was approximately 250 fpm (see Table 8). Measuring the response times proved difficult and unreliable as the large changes in air velocity produced small changes of detector response times. A testing modification was implemented which reduced the airflow of the smoke stream (see Appendix A: Air Velocity Testing Methodology), increasing the detector response times and allowing for the evaluation of higher velocities. This relationship also was demonstrated to be exponential with a high correlation value as

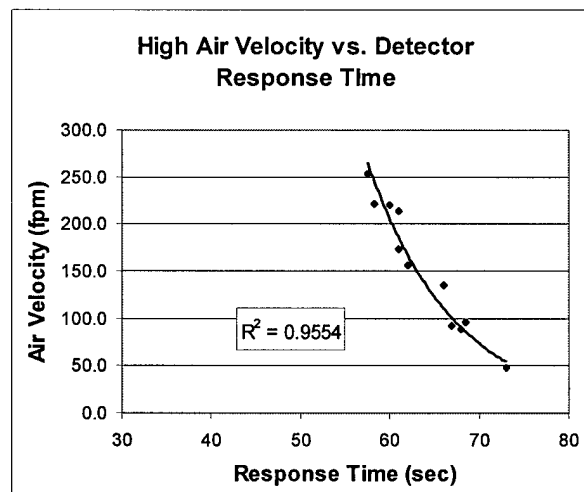

Figure 15. High Velocity versus Response Time Graph, From Table 8

seen in Figure 15. The activation concentrations were measured for the various air velocities for the photoelectric detectors. The results, when plotted, yielded a surprise

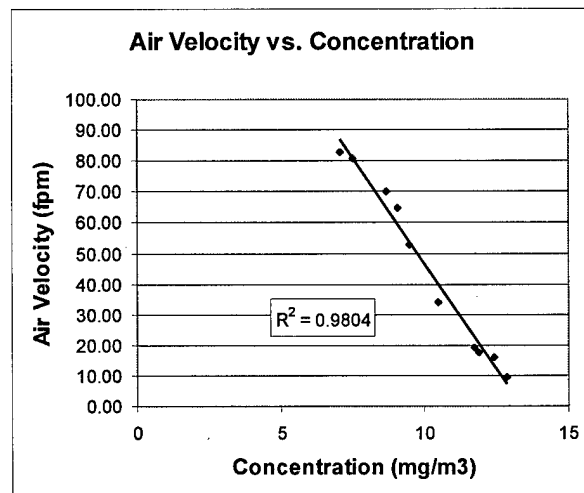

Figure 16. Velocity versus Concentration Graph for Photoelectric Detector. From Table 9.

linear relationship as shown in Figure 16. Initially, this relationship was expected to be exponential as well. But with a high correlation value of over 0.98, it is highly probable that it is a linear relationship. This disparity between relationships was observed before in another study on smoke (Whytlaw-Gray and Patterson 1932). In this study, the optical property of scattered light, also called the Tyndall effect or Tyndall beam, was studied for a suspension of smoke particles where the mass concentration was varied linearly with respect to time. This study also observed an exponential reduction in illumination as the mass concentration was reduced linearly by dilution. The authors suggested that this effect was probably due to the coagulation of particulate matter as the experiment occurred over a period of 30 minutes. They did not attempt to prove this by re-accomplishing the experiment by maintaining the mass concentration constant while watching for an exponential decrease in illumination. This observation using photoelectric smoke detectors is

similar as each air velocity value has a corresponding activation concentration and that by varying the air velocity, the concentrations also varied. As this experiment using photoelectric smoke detectors did not allow enough time for the coagulation of particles to occur, yet the same relationship was observed for varying concentrations, indicates that coagulation alone was not responsible for the corresponding changes in mass (linear) and illumination (exponential). This corresponding relationship is more likely to be a physical property of optics that follows the inverse square law for changes in illumination for corresponding changes in mass, requires the application of electromagnetic field theory, and is beyond the scope of this study.

#### **Air Velocity Testing Results for Ionization Detectors**

The same methods and procedures used for testing the air velocity effect for photoelectric detectors was applied to testing the ionization detectors. However, it became evident that resulting data did not indicate any recognizable relationship between the air velocity and the detector response time. After a careful review of operating procedures, testing parameters, testing equipment, replacement of ionization detectors, and repetition of the tests, the data as depicted in Figure 17 was an accurate representation of the relationship between the air velocity and the

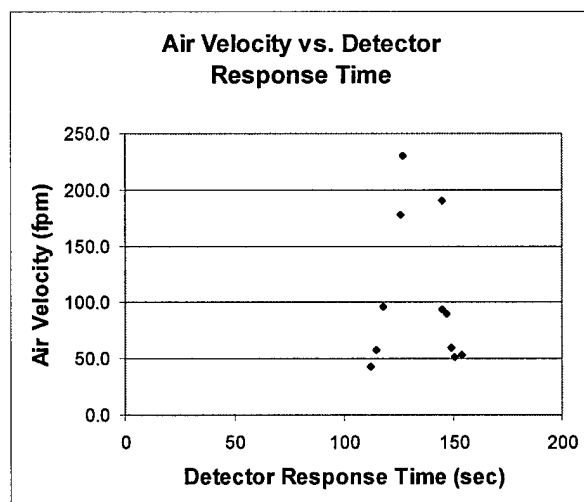

Figure 17. Velocity versus Response Time Graph for Ionization Detector. From Table 10.

detector response time for ionization detectors. After careful review of the data, a pattern emerged that was significant. The graph of the data, as depicted in Figure 17, roughly represented a bell-shaped curve about a mean response time of approximately 120 seconds. An observation was made that during the testing of the ionization detectors, they usually activated within a few seconds after a cigarette became spent and was being changed out. When the cigarettes were being changed, a minute fluctuation of airflow was heard as a small hissing sound. Therefore, it is probable that the changing of the cigarette is the primary cause for the ionization detector activation and that the response times are related to the changing of the cigarettes. In addition, the graph of the air velocity versus the activation concentrations in Figure 18 also demonstrates a similar bell-shaped curve about a mean activation concentration. This mean activation concentration, from Table 11, was determined

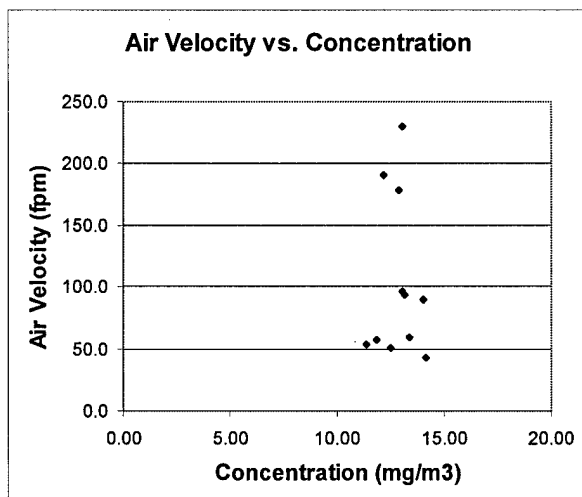

Figure 18. Velocity versus Concentration Graph for Ionization Detector

to be 12.87 mg/m<sup>3</sup> with a standard deviation of 0.81 mg/m<sup>3</sup>. Additional review of the data patterns in Figures 17 and 18 demonstrate that as the air velocity of the smoke particles increased, the closer the response times and activation concentrations were to the mean. Additional review of how an ionization smoke detector operates reveals that they depend on significant mass changes in the ionization field to activate. This supports the likelihood that the process of changing the cigarettes probably produced a minute fluctuation in airflow that caused a change in the mass of the smoke stream that was detectable by the ionization detector. As a test, the testing process for activation times with maximum air velocity was repeated twice with the cigarette change-out conducted before the first cigarette was spent and carefully as to prevent a fluctuation in airflow. The result was a doubling of the activation times with the detectors activating within a few seconds of the second cigarette becoming spent. This also disproves the observation made earlier in the Accuracy and Precision section that the photoelectric detectors respond quicker and at less concentration than ionization detectors. As a matter of fact, the ionization detectors activated only when

the second cigarette was spent and the airflow pattern of the smoke changed significantly enough to activate the detectors.

### **Reliability Issues**

Observations of the individual components of the smoke detectors during the testing indicated that they are rugged enough to survive rough handling from being worn by the user. No observed detriment in response capability indicated that film build-up from smoke did not occur inside the smoke detector sensors. However, as this issue is related to obtaining false positives, the issue is a minor one as the low cost of the detector allows for its replacement if it activates without a smoke issue.

### **Conclusions**

Based on the research conducted and the testing results obtained, the conclusion can be made that the photoelectric type smoke detector technology could be adapted to create a warning device for wildland firefighters to warn the user of smoke conditions that required respiratory protection. While both detectors were proved to have good accuracy and precision, only the photoelectric detector had a response that was related to the actual concentration of smoke particles. The ionization detector response was related to significant threshold changes in smoke particle concentrations but not an actual concentration. This effect renders the ionization detector unusable for the proposed purpose, as it cannot be adjusted to activate at a designed concentration threshold. The photoelectric detector response was found to be related to the mass presented at the detector and that the mass was proportional to the air

velocity of the smoke stream through the detector. Therefore, the sensitivity of the photoelectric detector could be set to activate for a specific concentration for an expected air velocity range. The sensitivity should be set for a ceiling level to prevent acute exposures and not for a time weighted average as reviewed in Chapter 2.

**Recommendations:**

As the smoke concentration correlation equations listed in Chapter 2 are related to carbon monoxide, additional studies should be conducted to determine if a household carbon monoxide detectors could also be adapted to create a ceiling level monitor for personal use. In developing a prototype device for monitoring respiratory hazards, the following recommendations should be accomplished. First, the device must be field tested in actual wildland firefighter situations. However, as wildland fires are unpredictable and irregular, this can be best simulated during prescribed burns that simulate real conditions. The detectors should be worn in a workers breathing zone as depicted in Figure 19. During the field tests, the individual smoke components that

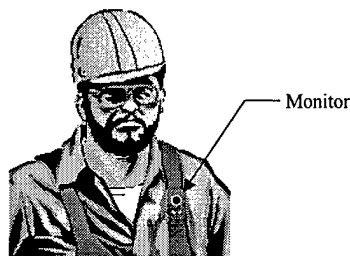

*Figure 19. Prototype of Air Monitoring Device*

cause acute respiratory effects and eye irritations (formaldehyde, acrolein, particulate matter, and carbon monoxide) should be simultaneously monitored on a direct reading instrument such as an infrared spectrometer or other like device. These

measured concentrations during alarm activation conditions would assist in the proper setting of the sensitivity levels to help focus the operation of the monitor on preventing acute respiratory effects as well as eye irritations. The sensitivity levels should have a slight safety factor to prevent false alarms (and worker mistrust) but yet provide valuable a warning alert. In addition, the sound pressure levels of the alarm will require reducing, as the original intent of the smoke alarms was to alert individuals of hazardous conditions at significant distances. Most smoke alarms produce over 85 dB at a distance of 10 feet, which is excessive and hazardous to hearing when the monitor is worn on the body. In conclusion, the best advantage of developing a low cost monitor is the ability to provide each worker with one and the ease of replacing a defective detector if damaged, defective, or lost (disposable monitoring devices).

## REFERENCES

- Babbitt, B. (1999). "Making Peace With Wildland Fire." *The World & I*, **14**: 170.
- Babbitt, B. and D. Glickman, (2000). Managing the Impact of Wildfires on Communities and the Environment. Washington, National Interagency Fire Center (NIFC).
- Bureau of Labor Statistics (1999). Fatalities Among Firefighters, <http://stats.bls.gov/opub/ted/1999/jul/wk1/art04.htm>, U.S. Department of Labor. **2000**.
- Burton, D. J., PE, CIH, (1988). "Engineering Control." *Occupational Health and Safety* **57** (November 1988): 3.
- Cone, M. (1990). Wildfire Crews Pay a Heavy Price in Health. *Los Angeles Times*. Los Angeles, California: 2.
- Craig, L., U.S. Senator (R-ID) (2000). Hearing on Preparedness for the Year 2000 Wildfires. *Committee on Energy and Natural Resources, Subcommittee on Forests and Public Lands Management*. Washington, Federal Document Clearing House: 45.
- Department of Health and Human Services (1986). The Health Consequences of Involuntary Smoking. Atlanta, Centers for Disease Control: 360.
- Greeley, A. (1957). Report of Fire Task Force, US Forestry Service, <http://www.fs.fed.us/r5/fire/1957>.

- Laverty, L. and D. Bosworth (2000). Summer Wildfires, Congressional Testimony.  
*House Resources Committee.*
- Litton, C. D. and M. Hertzberg (1977). Principles of Ionization Smoke Detection.  
Washington, US Department of the Interior, Bureau of Mines: 21.
- Managan, R. (1999). Wildland Fire Fatalities in the United States, 1990 - 1998.  
Missoula, United States Department of Agriculture (USDA) Forestry  
Service: 17.
- Mulholland, G. W. and R. Bukowski (1986). Application of Smoke Detector  
Technology to Quantitative Respirator Fit Test Methodology. Gaithersburg,  
Particle Technology Laboratory at the University of Minnesota, Department  
of Labor (OSHA): 52.
- National Fire Protection Association (1992). "New Mask for Wildland Firefighters."  
*Wildfire News and Notes* 6 (1): 8.
- National Wildfire Coordinating Group (NWCG) (2000). Wildland and Prescribed  
Fire Qualification System Guide, United States Department of Agriculture: 6.
- NIOSH WebPage (2001). Fire Fighter Fatality Investigation and Prevention Program,  
National Institute for Occupational Safety and Health  
<http://www.cdc.gov/niosh/facerpts.html>.
- Quincy, M. A. (1998). Standard on Protective Clothing and Equipment for Wildland  
Fire Fighting, NFPA 1977, National Fire Protection Association (NFPA).
- Reinhardt, T. E. and R. D. Ottmar (2000). Smoke Exposures at Western Wildfires.  
Portland, OR, USDA Forest Service, Pacific Northwest Research Station: 84.

- Reinhardt, T. E., R. D. Ottmar, et al. (1999). Guide to Monitoring Smoke Exposure of Wildland Firefighters. Portland, OR, USDA Forest Service, Pacific Northwest Research Station: 17.
- Schaenman, P., R. Hodges, et al. (1998). Wildland Firefighter Safety Awareness Study. Arlington, National Interagency Fire Center (NIFC): 349.
- Sharkey, B., PhD. (1997). Health Hazards of Smoke. Missoula, Montana, National Wildfire Coordinating Group (NWCG): 84.
- Sharp, D. (1998). Florida fires 'worse than hurricane'. *USA Today*. FRANCIS, Fla.: Pg. 1A.
- Tamas, J., Conformity Assessment Services Project Engineer (2001). "Re: Smoke Alarm Sensitivity Tests." Email to the author. Underwriters Laboratory, <http://www.ul.com/>, Northbrook ILL Office.
- Tangren, C. D., C. K. McMahon, et al. (1976). *Contents and Effects of Forrest Fire Smoke*. Macon, U.S. Department of Agriculture Forest Service.
- Udall, T. (2000). Firefighters Pay. *Government Reform Subcommittee on Civil Service, H.R. 2814*. Washington, Federal Document Clearing House: 3.
- Ward, D. E., Ph.D. (1997). *Review of Smoke Components*. Health Hazards of Smoke, Missoula, Montana.
- Weaver, W. A. (1992). "Health Hazards of Wildfire Smoke Under Study." *Fire Engineering* 6 (April): 28 - 31.
- Whytlaw-Gray, R., O.B.E., Ph.D., F.R.S. and H. S. Patterson (1932). *Smoke: A Study of Aerial Disperse Systems*. London, Edward Arnold & Co.

## BIBLIOGRAPHY

- American Conference of Governmental Industrial Hygienists (1998). *Industrial Ventilation: A Manual of Recommended Practice*, 23<sup>rd</sup> Edition. Cincinnati: American Conference of Governmental Industrial Hygienists, Inc.
- Dinardi, S., PhD, CiH (1998). *The Occupational Environment – Its Evaluation and Control*. Fairfax: American Industrial Hygiene Association (AIHA).
- Green, H. L. and W. R. Lane (1957). *Particulate Clouds: Dusts, Smokes, and Mists*. New York: D. Van Nostrand Company, Inc.
- Klaassen, Curtis PhD (1996). *Casarett and Doull's Toxicology: The Basic Science of Poisons*. New York: Magraw-Hill.
- Reinhold, V. N. and J. Perkins (1997). *Modern Industrial Hygiene, Recognition and Evaluation of Chemical Agents*, American Industrial Hygiene Association (AIHA).
- Stephen J. Pyne, Patricia L. Andrews, et al. (1996). *Introduction to Wildland Fires*. New York: John Wiley and Sons, Inc.

## **APPENDICES**

## Appendix A: Testing Methodology

### Smoke Chamber Testing:

1. Seal up the test chamber without any detectors on the testing shelf.
2. Activate the mixing fan in the smoke generation chamber and seal the chamber. Activate the pumps and allow them operate for several minutes to achieve a steady-state flow of air.
3. Insert a cigarette into each side of the cigarette holder located on the smoke generation chamber. Using a clamp, seal one side of the holder to prevent flow.
4. Light the cigarette on the open side and observe the smoke mixing and dispersion. If the cigarette will be completely used up before the experiment is completed, light the second cigarette and switch the clamp to the other cigarette holder.
5. The flow through the flow straighteners should produce even dispersion of smoke across the testing shelf. Reduce the speed of the fan in the generation chamber if significant particulate matter is removed from the flow stream. If the dispersion of smoke is uneven, additional flow straighteners may need to be added.
6. Record the observations and repeat the experiment using only one pump (low flow check). All final modifications should be based on observations of the low flow check.

### Detector Accuracy and Precision Testing:

1. Weigh the filter papers of at least 30 poly vinyl chloride (PVC) cassettes, 40 mm, 0.8 microns pore size. Mark each cassette and record their respective weights.
2. For each type of smoke detector, mark each of the five smoke detectors with the numbers 1 to 5. On the testing shelf, mark the five positions for the smoke detectors using the letters A through E. Activate each smoke alarm and ensure they are functioning properly by using the manufacturer's test button.
3. Use a random number generator or a die to determine the placement for each of the 5 detectors to be tested on the testing shelf. Place the 5 smoke detectors in the randomly determined positions in the test chamber.

## Appendix A: (continued)

4. Activate the circulating fans inside the testing chamber. Seal up the test chamber with on the testing shelf. Connect a filter cassette inline with each pump and connect them to both of the exhaust ports located on the bottom of the test chamber.
5. Activate the pumps and the mixing fan in the smoke generation chamber and seal the chamber.
6. Insert a cigarette into each side of the cigarette holder located on the smoke generation chamber. Using a clamp, seal one side of the holder to prevent flow. Allow for several minutes to achieve a steady-state flow of air.
7. Light the cigarette on the open side and record the time. Observe the smoke dispersion in and around the smoke detectors and watch for activation(s). If the cigarette will be completely used up before the experiment is concluded, light the second cigarette and switch the clamp to the other cigarette holder, and place a new cigarette into the original holder. Note: must be accomplished with no interruption of smoke flow.
8. The flow through the flow straighteners should produce even dispersion of smoke among the smoke detectors. Alter the location of the smoke detectors and repeat the experiment if the dispersion of smoke is unevenly distributed.
9. When the alarms activate, record the elapsed time required for each detector to activate. When all 5 have activated, remove the lit cigarette and begin timing the purge cycle. Record the number of cigarettes required.
10. When the purge cycle has reduce concentrations to 10 % of the maximum value (see calculations showing  $t = \sim 54$  minutes), shut off the pumps, remove the filter cassettes, and record the trial information on the set of cassettes. Record any observations.
11. Repeat the test cycle 4 more times by starting at line 3 above (random placement of detectors). Each test cycle will produce 5 activation times for each detector, a number of cigarettes used, and a filter cassette for each cycle.
12. Repeat the experiment for the other types of detectors. Each detector type test will produce 25 activation times, 5 sets of number of cigarettes used, and 5 filter cassettes.
13. Reweigh each filter cassette and determine the net weight increase. Using the stop time recorded for cycle and the pump flow rate of 2.8 liters per minute, determine the average concentration of collected material in milligrams per liter.

## Appendix A: (continued)

14. Determine the inter-group variability (homogeneity) by comparing response times for each detector weighted with the average concentration.
15. Compare the standard deviations of each position for each cycle to determine if there was bias related to positioning. If determined, correct for and repeat the experiment.
16. Determine the intra-group variability by comparing the mean response times for each type of detector divided by the mean of the averaged concentrations.
17. Draw conclusions about the response times for each type of detector based on the data and observations.

### Air Velocity Testing:

1. Insert into the main test chamber a device to rotate two smoke detectors at variable speeds. Remove the circulating fans from the main chamber. Place two of the same type detectors onto the rotating arm so that their sensors are at equal distance from the axis of rotation. Measure the distance from the axis of rotation to the center of the sensor and determine the circumference for one complete revolution.
2. Weigh the filter papers of 10 poly vinyl chloride (PVC) cassettes, 40-mm, 0.8 microns pore size. Mark each cassette and record their respective weights
3. Seal up the test chamber and insert a filter cassette in the line from each of the pumps to the two exhaust ports located on the bottom of the test chamber. Ensure an adequate seal is achieved.
4. Activate the mixing fan in the smoke generation chamber and seal the chamber. Activate the pumps and allow them to operate for several minutes to achieve a steady-state flow of air.
5. Activate the rotating mechanism and adjust the rotational speed to obtain the lowest air velocity possible while ensuring the rotational speed is constant and smooth.
6. Insert a cigarette into each side of the cigarette holder located on the smoke generation chamber.
7. Light the cigarettes and begin timing the experiment for each of the detectors. Light subsequent cigarettes needed to maintain a constant influx of smoke.

## Appendix A: (continued)

8. Carefully watch each detector for activation. When both have activated, discontinue the smoke generation and begin timing the purge cycle. Record the number of cigarettes required and the activation times.
9. When the purge cycle has reduce concentrations to 10 % of the maximum value (see calculations showing  $t = \sim 54$  minutes), shut off the pumps, remove the filter cassettes, and record the trial information on the set of cassettes. Record any observations
10. Repeat the experiment 4 more times using new filter cassettes but for each run, alter the rotational speed by at least 50 percent. Ensure similar operational conditions (time/number of cigarettes) are maintained. Ensure the test chamber is adequately purged from the previous cycle.
11. Reweigh the filter papers to determine the net weight increase of the filter paper.
12. Determine the relative smoke concentration (milligrams per liter) obtained for each cycle using the pump flow rates, net filter weight gains, and total sampling time. Plot the response times versus concentrations.
13. Using the response times and rotational speeds, determine the relationship between air speed and detector response times. Plot the response times versus air velocity.
14. An optional procedure, to reduce the velocity of the smoke (increase detector response sensitivity), is to reduce the flow rate for the activation sequence only or to activate the pumps for a set time (i.e. 1 min) prior to lighting the cigarettes (creating a vacuum, requiring smoke to be distributed throughout the chamber before passing through the detectors).

## **Appendix B: Glossary**

**Agency:** Any federal, state, or county government organization participating with jurisdictional responsibilities.

**Americium 241:** a white, metallic, radioactive isotope with atomic number of 95, primarily an alpha radiation emitter.

**Control a fire:** The complete extinguishment of a fire, including spot fires. Fireline has been strengthened so that flare-ups from within the perimeter of the fire will not break through this line.

**Drought Index:** A number representing net effect of evaporation, transpiration, and precipitation in producing cumulative moisture depletion in deep duff or upper soil layers.

**Entrapment:** A situation where personnel are unexpectedly caught in a fire behavior-related, life-threatening position where planned escape routes or safety zones are absent, inadequate, or compromised. An entrapment may or may not include deployment of a fire shelter for its intended purpose. These situations may or may not result in injury. They include "near misses."

**Fire Behavior:** The manner in which a fire reacts to the influences of fuel, weather and topography.

**Fire Crew:** An organized group of firefighters under the leadership of a crew leader or other designated official.

**Fire Front:** The part of a fire within which continuous flaming combustion is taking place. Unless otherwise specified the fire front is assumed to be the leading edge of the fire perimeter. In ground fires, the fire front may be mainly smoldering combustion.

**Fire Intensity:** A general term relating to the heat energy released by a fire.

**Fire Line:** A linear fire barrier that is scraped or dug to mineral soil.

**Fire Management Plan (FMP):** A strategic plan that defines a program to manage wildland and prescribed fires and documents the Fire Management Program in the approved land use plan. The plan is supplemented by operational plans such as preparedness plans, preplanned dispatch plans, prescribed fire plans, and prevention plans.

**Fire Perimeter:** The entire outer edge or boundary of a fire.

**Fire Season:** 1) Period(s) of the year during which wildland fires are likely to occur, spread, and affect resource values sufficient to warrant organized fire management activities. 2) A legally enacted time during which burning activities are regulated by state or local authority.

**Fire Shelter:** An aluminized tent offering protection by means of reflecting radiant heat and providing a volume of breathable air in a fire entrapment situation. Fire shelters should only be used in life-threatening situations, as a last resort.

**Flaming Front:** The zone of a moving fire where the combustion is primarily flaming. Behind this flaming zone combustion is primarily glowing. Light fuels typically have a shallow flaming front, whereas heavy fuels have a deeper front. Also called fire front.

**Fuel:** Combustible material. Includes, vegetation, such as grass, leaves, ground litter, plants, shrubs and trees, that feed a fire. (See Surface Fuels.)

**Fuel Moisture (Fuel Moisture Content):** The quantity of moisture in fuel expressed as a percentage of the weight when thoroughly dried at 212 degrees Fahrenheit.

**Head of a Fire:** The side of the fire having the fastest rate of spread.

**National Wildfire Coordinating Group:** A group formed under the direction of the Secretaries of Agriculture and the Interior and comprised of representatives of the U.S. Forest Service, Bureau of Land Management, Bureau of Indian Affairs, National Park Service, U.S. Fish and Wildlife Service and Association of State Foresters. The group's purpose is to facilitate coordination and effectiveness of wildland fire activities and provide a forum to discuss, recommend action, or resolve issues and problems of substantive nature. NWCG is the certifying body for all courses in the National Fire Curriculum.

**Normal Fire Season:** 1) A season when weather, fire danger, and number and distribution of fires are about average. 2) Period of the year that normally comprises the fire season.

**Pack Test:** Used to determine the aerobic capacity of fire suppression and support personnel and assign physical fitness scores. The test consists of walking a specified distance, with or without a weighted pack, in a predetermined period of time, with altitude corrections.

**Personnel Protective Equipment (PPE):** All firefighting personnel must be equipped with proper equipment and clothing in order to mitigate the risk of injury from, or exposure to, hazardous conditions encountered while working. PPE includes, but is not limited to: 8-inch high-laced leather boots with lug soles, fire shelter, hard hat with chin strap, goggles, ear plugs, aramid shirts and trousers, leather gloves and individual first aid kits.

**Prescribed Fire:** Any fire ignited by management actions under certain, predetermined conditions to meet specific objectives related to hazardous fuels or habitat improvement. A written, approved prescribed fire plan must exist, and NEPA requirements must be met, prior to ignition.

**Relative Humidity (Rh):** The ratio of the amount of moisture in the air, to the maximum amount of moisture that air would contain if it were saturated. The ratio of the actual vapor pressure to the saturated vapor pressure.

**Run (of a fire):** The rapid advance of the head of a fire with a marked change in fire line intensity and rate of spread from that noted before and after the advance.

**Smokejumper:** A firefighter who travels to fires by aircraft and parachute.

**Smoldering Fire:** A fire burning without flame and barely spreading.

**Suppression:** All the work of extinguishing or containing a fire, beginning with its discovery.

**Tyndall Effect:** also know as the Tyndall beam, named after Tyndall (1868) who was the first one to investigate the phenomenon of detection of particles by passing a beam of light through a suspension and observing the reflected/scattered beam.

**Tactics:** Deploying and directing resources on an incident to accomplish the objectives designated by strategy.

**Wildland Fire:** Any nonstructure fire, other than prescribed fire, that occurs in the wildland.

**Wildland Urban Interface:** The line, area or zone where structures and other human development meet or intermingle with undeveloped wildland or vegetative fuels.

## TEN STANDARD FIRE ORDERS

**F**ight fire aggressively but provide for **safety first**.

**I**nitiate all action based on current and expected **fire behavior**.

**R**ecognize current **weather conditions** and obtain forecasts.

**E**nsure that **instructions** are given and understood.

**O**btain current information on **fire status**.

**R**emain in **communication** with crewmembers, your supervisor, and adjoining forces.

**D**etermine **safety zones** and **escape routes**.

**E**stablish **lookouts** in potentially hazardous situations.

**R**etain **control** at all times.

**S**tay **alert**, keep **calm**, **think** clearly, and **act** decisively.

## 18 WATCHOUTS

1. Fire not scouted and sized up.
2. In country not seen in daylight.
3. Safety zones and escape routes not identified.
4. Unfamiliar with weather and local factors influencing fire behavior.
5. Uninformed on strategy, tactics, and hazards.
6. Instructions and assignments not clear.
7. No communication link between crewmembers and supervisors.
8. Constructing line without safe anchor point.
9. Building line downhill with fire below.
10. Attempting frontal assault on fire.
11. Unburned fuel between you and the fire.
12. Cannot see main fire, not in contact with anyone who can.
13. On a hillside where rolling material can ignite fuel below.
14. Weather gets hotter and drier.
15. Wind increases and/or changes direction.
16. Getting frequent spot fires across line.
17. Terrain or fuels make escape to safety zones difficult.
18. Feel like taking a nap near fireline.

## Appendix D: Raw Data

### Detector Accuracy and Precision Testing:

Table 3  
Photoelectric Detector Response Times

Trial	Detector Position (Random)					Detector Response Times					Position Response Times				
	1	2	3	4	5	1	2	3	4	5	A	B	C	D	E
1	E	C	D	B	A	51	59	58	54	57	57	54	59	58	51
2	C	D	A	E	B	56	58	58	56	59	58	59	56	58	56
3	C	A	E	B	E	56	57	56	56	56	57	56	56	56	56
4	A	B	E	D	C	59	63	61	57	63	59	63	63	57	61
5	C	B	E	A	D	51	64	50	59	56	59	64	51	56	50
					Mean	55	60	57	56	58	58	59	57	57	55
					SD	3.5	3.1	4.1	1.8	2.9	1.0	4.3	4.4	1.0	4.4

Table 4  
Photoelectric Detector Response Concentrations

Trial	# Cig	Pre-Weight (g)		Post-Weight (g)		Total (mg)	t (min)	vol (L)	C (mg/m <sup>3</sup> )
		Cassette 1	Cassette 2	Cassette 1	Cassette 2				
1	1	0.03292	0.03346	0.03558	0.03597	5.17	54	302.4	17.10
2	1	0.03194	0.03301	0.03420	0.03533	4.58	54	302.4	15.15
3	1	0.03516	0.03524	0.03769	0.03761	4.90	54	302.4	16.20
4	1	0.03270	0.03287	0.03525	0.03497	4.65	54	302.4	15.38
5	1	0.03451	0.03371	0.03680	0.03585	4.43	54	302.4	14.65
								Mean	15.69
								SD	0.96

Note: All weights measured with Mettler AE 163 Scale, s/ 11332, Cal 2/17/01

Table 5  
Ionization Detector Response Times

Trial	Position (Random)					Detector Response Times					Position Response Times				
	1	2	3	4	5	1	2	3	4	5	A	B	C	D	E
1	D	C	E	A	B	102	96	98	98	95	98	95	96	102	98
2	D	E	A	B	C	106	102	101	104	101	101	104	101	106	102
3	B	C	D	E	A	101	97	99	95	100	100	101	97	99	95
4	A	E	D	B	C	105	106	101	102	102	105	102	102	101	106
5	E	A	B	C	D	106	102	101	99	100	102	101	99	100	106
					Mean	104	101	100	100	100	101	101	99	102	101
					SD	2.3	4.1	1.4	3.5	2.7	2.6	3.4	2.5	2.7	4.9

## Appendix D: (Continued)

Table 6  
Ionization Detector Response Concentrations

Trial	# Cig	Pre-Weight (g)		Post-Weight (g)		Total (mg)	t (min)	vol (L)	C (mg/m <sup>3</sup> )	
		Cassette 1	Cassette 2	Cassette 1	Cassette 2					
1	2	0.03233	0.03119	0.03687	0.03640	9.75	54	302.4	32.24	
2	2	0.03150	0.03115	0.03615	0.03645	9.95	54	302.4	32.90	
3	2	0.03212	0.03329	0.03853	0.03644	9.56	54	302.4	31.61	
4	2	0.03170	0.03218	0.03663	0.03672	9.47	54	302.4	31.32	
5	2	0.03211	0.03179	0.03676	0.03721	10.07	54	302.4	33.30	
									Mean	32.27
									SD	0.84

Note: All weights measured with Mettler AE 163 Scale, s/ 11332, Cal 2/17/01

## Air Velocity Testing Results:

Table 7  
Air Velocity Relationship for Photoelectric Detector Response

t <sub>10CYC</sub> (sec)	RPM	r (inches)	fpm	t <sub>R</sub> (sec)
89.7	6.7	2.69	9.4	123
52.0	11.5	2.69	16.2	110
47.5	12.6	2.69	17.8	114
44.0	13.6	2.69	19.2	94
36.0	16.7	2.69	23.5	101
24.8	24.2	2.69	34.1	84
16.0	37.6	2.69	52.9	63
13.0	46.2	2.69	64.9	60
12.0	49.8	2.69	70.1	48
10.5	57.4	2.69	80.7	46
10.2	58.7	2.69	82.6	55

t<sub>10CYC</sub> (sec) = time required to complete 10 cycles

t<sub>R</sub> (sec) = detector response time

Table 8  
High Air Velocity Relationship for Photoelectric Detector Response

t <sub>10CYC</sub> (sec)	RPM	r (inches)	fpm	t <sub>R</sub> (sec)
32.9	18.2	5.00	47.7	73
19.5	30.8	5.50	88.7	68
18.7	32.1	5.50	92.3	67
18.1	33.2	5.50	95.6	69
12.8	46.8	5.50	134.8	66
11.0	54.4	5.50	156.6	62
10.0	60.3	5.50	173.6	61
7.3	81.7	5.00	213.9	61
7.9	76.4	5.50	220.0	60
7.1	84.5	5.00	221.1	58
6.8	87.8	5.50	252.9	58

t<sub>10CYC</sub> (sec) = time required to complete 10 cycles

t<sub>R</sub> (sec) = detector response time

## Appendix D: (Continued)

Table 9  
Airflow - Concentration Relationship for Photoelectric Detectors

fpm	Pre wt (g)	Post wt (g)	Total (mg)	t (min)	vol (L)	C (mg/m <sup>3</sup> )
9.40	0.03361	0.03750	3.89	54	302.4	12.86
16.20	0.03167	0.03543	3.76	54	302.4	12.43
17.80	0.03115	0.03475	3.60	54	302.4	11.90
19.20	0.03210	0.03565	3.55	54	302.4	11.74
34.10	0.03159	0.03475	3.17	54	302.4	10.47
52.90	0.03142	0.03429	2.87	54	302.4	9.47
64.90	0.03155	0.03429	2.74	54	302.4	9.06
70.10	0.03118	0.03379	2.62	54	302.4	8.65
80.70	0.03729	0.03956	2.27	54	302.4	7.51
82.60	0.03763	0.03976	2.13	54	302.4	7.04

Note: All weights measured with Mettler AE 163 Scale, s/ 11332, Cal 2/17/01

Table 10  
Air Velocity Relationship for Ionization Detector Response

t <sub>10CYC</sub> (sec)	RPM	r (inches)	fpm	t <sub>R</sub> (sec)
40.1	15.0	5.50	43.1	112
34.0	17.6	5.50	50.8	151
32.3	18.6	5.50	53.5	154
30.0	20.0	5.50	57.6	115
29.3	20.5	5.50	59.0	149
19.2	31.3	5.50	90.0	147
18.5	32.5	5.50	93.6	145
18.0	33.4	5.50	96.1	118
9.7	61.9	5.50	178.1	126
9.1	66.2	5.50	190.7	145
7.5	80.0	5.50	230.4	127

t<sub>10CYC</sub> (sec) = time required to complete 10 cycles

t<sub>R</sub> (sec) = detector response time

## Appendix D: Raw Data

### Detector Accuracy and Precision Testing:

Table 3  
Photoelectric Detector Response Times

Trial	Detector Position (Random)					Detector Response Times					Position Response Times				
	1	2	3	4	5	1	2	3	4	5	A	B	C	D	E
1	E	C	D	B	A	51	59	58	54	57	57	54	59	58	51
2	C	D	A	E	B	56	58	58	56	59	58	59	56	58	56
3	C	A	D	B	E	56	57	56	56	56	57	56	56	56	56
4	A	B	E	D	C	59	63	61	57	63	59	63	63	57	61
5	C	B	E	A	D	51	64	50	59	56	59	64	51	56	50
Mean						55	60	57	56	58	58	59	57	57	55
SD						3.5	3.1	4.1	1.8	2.9	1.0	4.3	4.4	1.0	4.4
CV%						6.4	5.2	7.2	3.2	5.1					

Table 4  
Photoelectric Detector Response Concentrations

Trial	# Cig	Pre-Weight (g)		Post-Weight (g)		Total (mg)	t (min)	vol (L)	C (mg/m <sup>3</sup> )
		Cassette 1	Cassette 2	Cassette 1	Cassette 2				
1	1	0.03292	0.03346	0.03558	0.03597	5.17	54	302.4	17.10
2	1	0.03194	0.03301	0.03420	0.03533	4.58	54	302.4	15.15
3	1	0.03516	0.03524	0.03769	0.03761	4.90	54	302.4	16.20
4	1	0.03270	0.03287	0.03525	0.03497	4.65	54	302.4	15.38
5	1	0.03451	0.03371	0.03680	0.03585	4.43	54	302.4	14.65
Mean									15.69
SD									0.96

Note: All weights measured with Mettler AE 163 Scale, s/ 11332, Cal 2/17/01

Table 5  
Ionization Detector Response Times

Trial	Position (Random)					Detector Response Times					Position Response Times				
	1	2	3	4	5	1	2	3	4	5	A	B	C	D	E
1	D	C	E	A	B	102	96	98	98	95	98	95	96	102	98
2	D	E	A	B	C	106	102	101	104	101	101	104	101	106	102
3	B	C	D	E	A	101	97	99	95	100	100	101	97	99	95
4	A	E	D	B	C	105	106	101	102	102	105	102	102	101	106
5	E	A	B	C	D	106	102	101	99	100	102	101	99	100	106
Mean						104	101	100	100	100	101	101	99	102	101
SD						2.3	4.1	1.4	3.5	2.7	2.6	3.4	2.5	2.7	4.9
CV%						2.3	4.1	1.4	3.5	2.7					

## Appendix D: (Continued)

Table 6  
Ionization Detector Response Concentrations

Trial	# Cig	Pre-Weight (g)		Post-Weight (g)		Total (mg)	t (min)	vol (L)	C (mg/m <sup>3</sup> )	
		Cassette 1	Cassette 2	Cassette 1	Cassette 2					
1	2	0.03233	0.03119	0.03687	0.03640	9.75	54	302.4	32.24	
2	2	0.03150	0.03115	0.03615	0.03645	9.95	54	302.4	32.90	
3	2	0.03212	0.03329	0.03853	0.03644	9.56	54	302.4	31.61	
4	2	0.03170	0.03218	0.03663	0.03672	9.47	54	302.4	31.32	
5	2	0.03211	0.03179	0.03676	0.03721	10.07	54	302.4	33.30	
									Mean	32.27
									SD	0.84

Note: All weights measured with Mettler AE 163 Scale, s/ 11332, Cal 2/17/01

## Air Velocity Testing Results:

Table 7  
Air Velocity Relationship for Photoelectric Detector Response

t <sub>10CYC</sub> (sec)	rpm	r (inches)	fpm	t <sub>R</sub> (sec)
89.7	6.7	2.69	9.4	123
52.0	11.5	2.69	16.2	110
47.5	12.6	2.69	17.8	114
44.0	13.6	2.69	19.2	94
36.0	16.7	2.69	23.5	101
24.8	24.2	2.69	34.1	84
16.0	37.6	2.69	52.9	63
13.0	46.2	2.69	64.9	60
12.0	49.8	2.69	70.1	48
10.5	57.4	2.69	80.7	46
10.2	58.7	2.69	82.6	55

t<sub>10CYC</sub> (sec) = time required to complete 10 cycles

t<sub>R</sub> (sec) = detector response time

Table 8  
High Air Velocity Relationship for Photoelectric Detector Response

t <sub>10CYC</sub> (sec)	rpm	r (inches)	fpm	t <sub>R</sub> (sec)
32.9	18.2	5.00	47.7	73
19.5	30.8	5.50	88.7	68
18.7	32.1	5.50	92.3	67
18.1	33.2	5.50	95.6	69
12.8	46.8	5.50	134.8	66
11.0	54.4	5.50	156.6	62
10.0	60.3	5.50	173.6	61
7.3	81.7	5.00	213.9	61
7.9	76.4	5.50	220.0	60
7.1	84.5	5.00	221.1	58
6.8	87.8	5.50	252.9	58

t<sub>10CYC</sub> (sec) = time required to complete 10 cycles

t<sub>R</sub> (sec) = detector response time

## Appendix D: (Continued)

Table 9  
Airflow - Concentration Relationship for Photoelectric Detectors

fpm	Pre wt.(g)	Post wt.(g)	Total (mg)	t (min)	vol (L)	C (mg/m <sup>3</sup> )
9.40	0.03361	0.03750	3.89	54	302.4	12.86
16.20	0.03167	0.03543	3.76	54	302.4	12.43
17.80	0.03115	0.03475	3.60	54	302.4	11.90
19.20	0.03210	0.03565	3.55	54	302.4	11.74
34.10	0.03159	0.03475	3.17	54	302.4	10.47
52.90	0.03142	0.03429	2.87	54	302.4	9.47
64.90	0.03155	0.03429	2.74	54	302.4	9.06
70.10	0.03118	0.03379	2.62	54	302.4	8.65
80.70	0.03729	0.03956	2.27	54	302.4	7.51
82.60	0.03763	0.03976	2.13	54	302.4	7.04

Note: All weights measured with Mettler AE 163 Scale, s/ 11332, Cal 2/17/01

Table 10  
Air Velocity Relationship for Ionization Detector Response

t <sub>10CYC</sub> (sec)	rpm	r (inches)	fpm	t <sub>R</sub> (sec)
40.1	15.0	5.50	43.1	112
34.0	17.6	5.50	50.8	151
32.3	18.6	5.50	53.5	154
30.0	20.0	5.50	57.6	115
29.3	20.5	5.50	59.0	149
19.2	31.3	5.50	90.0	147
18.5	32.5	5.50	93.6	145
18.0	33.4	5.50	96.1	118
9.7	61.9	5.50	178.1	126
9.1	66.2	5.50	190.7	145
7.5	80.0	5.50	230.4	127

t<sub>10CYC</sub> (sec) = time required to complete 10 cycles

t<sub>R</sub> (sec) = detector response time

**Appendix D: (Continued)**

Table 11  
Airflow - Concentration Relationship for Ionization Detectors

ftm	Pre wt.(g)	Post wt.(g)	Total (mg)	t (min)	vol (L)	C (mg/m3)
43.1	0.03102	0.03529	4.27	54	302.4	14.12
50.8	0.03159	0.03537	3.78	54	302.4	12.50
53.5	0.03216	0.03559	3.43	54	302.4	11.34
57.6	0.03383	0.03741	3.58	54	302.4	11.84
59.0	0.03209	0.03614	4.05	54	302.4	13.39
90.0	0.03178	0.03602	4.24	54	302.4	14.02
93.6	0.03352	0.03750	3.98	54	302.4	13.16
96.1	0.03102	0.03497	3.95	54	302.4	13.06
178.1	0.03195	0.03585	3.90	54	302.4	12.90
190.7	0.03320	0.03689	3.69	54	302.4	12.20
230.4	0.03228	0.03622	3.94	54	302.4	13.03
Mean						12.87
SD						0.81

Note: All weights measured with Mettler AE 163 Scale, s/ 11332, Cal 2/17/01

APPLICATION OF SMOKE DETECTOR TECHNOLOGY TO MINIMIZE  
SMOKE EXPOSURES TO WILDLAND FIREFIGHTERS

by

SCOTT F. WALTER

*An Abstract*

of a thesis submitted in partial fulfillment  
of the requirements for the degree of  
Master of Science in Public Health  
Department of Environmental and Occupational Health  
College of Public Health  
University of South Florida

May 2001

Major Professor: Yehia Hammad, Ph.D.

Personnel who fight wildland fires are limited to the amount of protective equipment that they can carry with them. Bulky respiratory protection devices are considered extraneous to a smoke jumper who must carry all their tools and living necessities on their backs. In addition, respirators cannot filter out carbon monoxide, a significant airborne hazard from wildland fires. Instead, personnel are trained to recognize and avoid inhalation exposure situations eliminating the need for respiratory protection.

Most of the personnel who fight wildland fires are augmentees who are often poorly trained, lack experience, and are inadequately equipped to safely respond to the fire. In addition, wildland firefighters often lack the experience of responding to a large fire. Lastly, inhalation exposure conditions (concentrations, wind speed, wind direction, etc.) vary with each wildland fire encountered, which increases the exposure potential.

Most studies of the inhalation hazards from wildland fires indicate individual exposure levels of measurable contaminants were below the permissible exposure limits (PELs) established by the Occupational Safety and Health Administration (OSHA) with an incident overexposure rate of approximately 5 – 10 %. These exposures were attributed to lack of worker training or awareness of the existing inhalation hazard. The primary health effect reported was upper respiratory and eye irritation (mainly from acrolein, formaldehyde, and particulate matter exposure). For comfort, workers often wear scarves and bandanas to reduce the discomfort of smoke

exposure. For eye protection, some workers may wear goggles with limited protective capacity.

This study focused on the application of smoke detector technology to develop a low cost, disposable, effective, dependable personal alarm to alert wildland firefighters when potentially hazardous smoke conditions are encountered so that appropriate action can be taken. Smoke detector technology was considered due to the low unit costs created by the mass production of smoke detectors (unit costs under \$20 each). Two basic smoke detector technologies were considered for evaluation: ionization and photoelectric smoke alarms.

This study determined if smoke detector technology could be utilized for preventing exposures, which type of detection technology was the most effective, and evaluated the effectiveness of this type of a monitor to reduce both the short term and long term health hazards.

Abstract Approved: \_\_\_\_\_



Major Professor: Yehia Hammad, Sc.D.  
Professor, Department of Environmental and Occupational Health

Date Approved: \_\_\_\_\_