

REPORT DOCUMENTATION PAGE			Form Approved OMB No. 0704-0188		
Public reporting burden for this collection of information is estimated to average 1 hour per response, including the time for reviewing instructions, searching existing data sources, gathering and maintaining the data needed, and completing and reviewing this collection of information. Send comments regarding this burden estimate or any other aspect of this collection of information, including suggestions for reducing this burden, to Department of Defense, Washington Headquarters Services, Directorate for Information Operations and Reports (0704-0188), 1215 Jefferson Davis Highway, Suite 1204, Arlington, VA 22202-4302. Respondents should be aware that notwithstanding any other provision of law, no person shall be subject to any penalty for failing to comply with a collection of information if it does not display a currently valid OMB control number. PLEASE DO NOT RETURN YOUR FORM TO THE ABOVE ADDRESS.					
1. REPORT DATE		2. REPORT TYPE Professional Paper	3. DATES COVERED		
4. TITLE AND SUBTITLE Fibre Channel Avionics Bus Monitor			5a. CONTRACT NUMBER		
			5b. GRANT NUMBER		
			5c. PROGRAM ELEMENT NUMBER		
6. AUTHOR(S) Sid Jones			5d. PROJECT NUMBER		
			5e. TASK NUMBER		
			5f. WORK UNIT NUMBER		
7. PERFORMING ORGANIZATION NAME(S) AND ADDRESS(ES) Naval Air Warfare Center Aircraft Division 22347 Cedar Point Road, Unit #6 Patuxent River, Maryland 20670-1161			8. PERFORMING ORGANIZATION REPORT NUMBER		
9. SPONSORING/MONITORING AGENCY NAME(S) AND ADDRESS(ES)			10. SPONSOR/MONITOR'S ACRONYM(S)		
			11. SPONSOR/MONITOR'S REPORT NUMBER(S)		
12. DISTRIBUTION/AVAILABILITY STATEMENT Approved for public release; distribution is unlimited.					
13. SUPPLEMENTARY NOTES					
14. ABSTRACT The following document is the result of a semester long independent study course at Johns Hopkins University (JHU). This document discusses the concept development stage of a conceivable system to monitor data from a Fibre Channel avionics bus for test purposes. Specifically, it addresses the system need (why) and the system requirements (what). The document also contains several top-level discussions as to implementation options (how). This document was a tool used by JHU to assess my ability to apply skills and processes learned throughout the JHU Systems Engineering curriculum. It is important to keep in mind this document was written by me to satisfy JHU requirements and does not necessarily reflect the views of the naval Air Warfare Center. This was a semester long project and many of the ideas and concepts will need to be further developed and refined to be useful to a funded development effort. Now that the class is complete, it is my sincere hope that the Telemetry Community will find this document useful in pursuing the development of a Fibre Channel Avionics Bus Monitor System.					
15. SUBJECT TERMS Fibre Channel Avionics Bus Monitor					
16. SECURITY CLASSIFICATION OF:			17. LIMITATION OF ABSTRACT	18. NUMBER OF PAGES 41	19a. NAME OF RESPONSIBLE PERSON Sid Jones
a. REPORT	b. ABSTRACT	c. THIS PAGE			19b. TELEPHONE NUMBER (include area code) (301) 342-1601

Standard Form 298 (Rev. 8-98)
Prescribed by ANSI Std. Z39-18

20010716 018

Fibre Channel Avionics Bus Monitor

Johns Hopkins University
System Engineering Project

Sid Jones
February 27, 2001

Fibre Channel Avionics Bus Monitor

Final Report

**Johns Hopkins
System Engineering Project**

Course No. 645.770

Sid Jones
February 27, 2001

Ray Schulmeyer
Advisor

Table of Contents

1 STATEMENT OF OBJECTIVE AND APPROACH

2 SIGNIFICANCE OF SCOPE OF WORK

3 DESCRIPTION OF PRODUCTS/RESULTS

3.1 PROJECT CONCEPT

3.2 PROJECT PROPOSAL

3.3 STATEMENT OF NEED

3.4 OPERATIONAL CONCEPT DOCUMENT

3.5 EXTERNAL INTERFACE REQUIREMENTS

3.6 SYSTEM REQUIREMENTS

3.7 TRADE STUDIES

3.8 INTERIM REPORT

3.9 SYSTEM REQUIREMENTS SPECIFICATION

3.10 FINAL REPORT/PRESENTATION

4 PROJECT EVALUATION

5 CONCLUSIONS AND RECOMMENDATIONS

APPENDIX A PROJECT CONCEPT

APPENDIX B PROJECT PROPOSAL

APPENDIX C STATEMENT OF NEED

APPENDIX D OPERATIONAL CONCEPT DOCUMENT

APPENDIX E EXTERNAL INTERFACE REQUIREMENTS

APPENDIX F SYSTEM REQUIREMENTS DOCUMENT

APPENDIX G TRADE STUDY – BUS TAP METHOD

APPENDIX H TRADE STUDY – DEVELOPMENT TECHNOLOGY

APPENDIX I INTERIM REPORT

APPENDIX J SYSTEM REQUIREMENTS SPECIFICATION

APPENDIX K FINAL REPORT PRESENTATION

Preface

The following document is the result of a semester long independent study course at Johns Hopkins University (JHU). This document discusses the concept development stage of a conceivable system to monitor data from a Fibre Channel avionics bus for test purposes. Specifically it addresses the system need (why) and the system requirements (what). The document also contains several top-level discussions as to implementation options (how).

This document was a tool used by JHU to assess my ability to apply skills and processes learned throughout the JHU Systems Engineering curriculum. It is important to keep in mind this document was written by me to satisfy JHU requirements and **does not necessarily reflect the views of the Naval Air Warfare Center**. This was a semester long project and many of the ideas and concepts will need to be further developed and refined to be useful to a funded development effort.

Now that the class is complete, it is my sincere hope that the Telemetry Community will find this document useful in pursuing the development of a Fibre Channel Avionics Bus Monitor System.

Sid Jones

1 Statement of Objective and Approach

There were two major objectives to this project. The first was to apply the knowledge gained through the Johns Hopkins System Engineering curriculum to a real world problem. The second was to use the processes, skills, and concepts learned on the selected project to lay the ground work for a development program.

Test and Evaluation (T&E) data systems acquire data from a test or mission from a variety of sources depending on the type of test being performed. These sources include avionics computers, avionics busses, aircraft subsystems, and a host of specific transducers. The vast majority of installations require monitoring the data being sent between the avionics computers over the avionics bus. For the past twenty years, the avionics bus used in most aircraft is the Mil-Std-1553 multiplex bus. The architecture and speed of the Mil-Std-1553 bus made monitoring the data relatively easy. During the last couple of years, it was discovered that several airframes were looking at a new technology (i.e. Fibre Channel) for the aircraft's avionics busses. Fibre Channel utilizes a high-speed network architecture that requires a significantly different approach to monitor the data during a flight test.

The objective of this project was to develop a systems requirement specification (A-Spec) for a Fibre Channel Avionics Bus Monitor. The resultant specification would be used as the basis for a development or research contract. In developing the A-Spec, the systems engineering approach was used as a model for defining and executing the activities and tasks required. The project was grouped into three phases that provided an organized sequence of system engineering activities. The first phase was Problem Definition in which the needs and operational concepts were identified and defined. The second phase was Functional Analysis in which the requirements analysis and assessment was completed. The third phase was Physical Analysis where trade-off studies and the final A-Spec were completed.

2 Significance of Scope of Work

The significance of this project personally is that it forced me to think through the project goals from a systems engineering perspective. From a broader perspective, I think this project will motivate the community to consider this problem. As budgets get tightened and work load increases, many agencies focus on the task at hand. They wonder where the latest fire drill came from and why they didn't see it coming. I believe this could potentially be the case with monitoring advanced network based avionics systems. The goal is to foster an interest by using the A-Spec as the basis for a research or development contract. However, even if there is no product produced as a direct result of this project, a product will be produced in the near future that will have roots going back to the efforts of this project.

Lessons Learned

- While a lot of work, this project provided the opportunity to follow the system engineering approach through a significant portion of a real world project. We were taught the traditional systems engineering waterfall with feedback paths. During this project, I was required to constantly keep the whole concept in mind while working on particular pieces. While producing subsequent products, new thoughts and ideas emerge that require updating previous documents. Doing individual documents piecemeal throughout the curriculum, some of this gets lost.

- Along these lines, the concept of tailoring the documents hit home. While writing the Systems Engineering Master Plan (SEMP) in a previous class, we were told to tailor it appropriately. Once you're immersed in a real world project, the concept of tailoring crystallizes. There were some aspects to the documents that didn't fit the task at hand while in other cases there were pieces that needed to be added.
- I did a fair job of estimating the work required for the project, but I did a less than stellar job of estimating the rate at which the tasks would get done. A good schedule must not only have the appropriate task levels, but must be realistic in the time line as well. I should have reassessed my schedule more often to keep better tabs on the project.
- User feedback is an important element of the system engineering process. However, in these days of doing more with less, many people barely have time to do their own jobs without worrying about reviewing documents for another project. Such was the case during this project. 'User feedback' came in the form of doing more up-front discussions before writing the document.
- The use of trade studies is very important from a systems engineering approach. One thing that is not emphasized enough is the two reasons to do a trade study have slightly different requirements. A good trade study must fully address both. The obvious reason is use a systematic approach to make a decision between competing solutions. However, in doing that, it is not enough to choose the best candidate. The trade study should be written from the perspective that you will need to defend your choice at some later time. This means ensuring all assumptions, alternatives, etc are documented.

3 Description of Products/Results

3.1 Project Concept

- Identifies a JHU System Engineering Project concept.
- Documents the project concept for acceptance.
- Additional concept information provided in response to questions.

3.2 Project Proposal

- Identifies the project objectives.
- States the need for the proposed system.
- Describes the products to be generated.
- Identifies the system engineering scope of the project.
- Identifies the resources required for the project.
- Identifies the preliminary task breakdown.
- Provides the project milestones and master schedule.
- Provides a project risk assessment.

3.3 Statement of Need

- Identifies why the Fibre Channel Avionics Bus is needed.
- Identifies the scope of the project.
- Provides background information pertinent to the project.
- Describes deficiencies in current bus monitor systems.
- Lists non-materiel alternatives considered adequate.
- Lists potential materiel alternatives.
- Identifies constraints placed on the system.

3.4 Operational Concept Document

- Identifies the state of the current system.
- Identifies justification for proposed changes.
- Provides the concept envisioned for the new or improved system.
- Describes how the new system will be utilized.
- Identifies impacts the new system will have on current operations.

3.5 External Interface Requirements

- Identifies the external interfaces as seen by a Fibre Channel Avionics Bus Monitor.
- Describes each of the external interfaces in detail.

3.6 System Requirements

- Defines the system operational requirements.
- Describes the system in relation to interfacing systems.
- Describes a conceptual operation of the system.

3.7 Trade Studies

- Provides a systematic approach to select among a group of alternatives.
- Describes each alternative.
- Identifies the criterion in which the selection is based.
- Describes approach and identifies selection.

3.8 Interim Report

- Provides a detailed look at the status of the project.
- Reaffirms or updates project objectives, approach, and schedule.
- Summarizes the progress achieved to date.

3.9 System Requirements Specification

- Defines the minimum system capabilities required for the system.
- Correlates system capability requirements to the required states and modes of the system.
- Identifies design constraints for compatibility of system hardware.
- Provides matrix to qualify system requirements.

3.10 Final Report/Presentation

- Provides the final status of the project.
- All project deliverables are combined into one document.
- Provides conclusions and recommendations on any additional effort required.
- Summarizes project in oral presentation.

4 Project Evaluation

The project provided a good opportunity to apply the skills and techniques learned throughout the curriculum to something real. The project impressed two major ideas on me. The first was that even though you think you have a good grasp on the project, working systematically through each activity forces you to think along lines you hadn't considered at first. The second was along with the first idea; the iterative nature of a systems approach really stands out.

I feel this work has met both objectives stated up front. The first was to apply what was learned in the program to a real project. In spite of the amount of work this project has been, I feel it has solidified my knowledge and confidence in the systems engineering area significantly. The

second objective was to develop a requirements specification for a Fibre Channel Bus Monitor (which can be found in appendix J). Regardless whether a development contract is generated as a result of this project or is provided to interested vendors as reference material, I feel the project has been successful. At the very least, the community (government and vendors) will be aware of the need for such a capability and will hopefully act from an informed position whether to pursue a development or not.

The overall estimate of the work required to complete this project was not far from the actual values. This is mostly due in part to the guidance concerning the scope given in the project handout than to good estimation practices on my part. I uniformly had to increase my estimate by 50%. As a result, that turned out to be a good data point unto itself. I know that I typically estimate work requirements low and must compensate. Table 1 provides the comparison of estimated hours to actual hours.

Table 1 Project Summary (Hours per Task)

Task	Estimated Hours	Actual Hours
Write Concept	10	11
Proposal	15	18
Needs analysis	15	17
Requirements Analysis	---	---
Concept of Operations	39	39
Identify external interfaces	16	23
Identify system requirements	10	16
Trade Studies	---	---
Bus tap method	29	23
Development Technology	25	27
Interim Report	12	6
System Specification	29	23
Final Report	15	13
Oral Report	7	12
Total	222	228

5 Conclusions and Recommendations

One of the difficult aspects of this project has been the desire to develop a capability nearly in parallel with the technology it needs to monitor. The weapons platforms that are upgrading their avionics systems are still in their infancy. Many interface documents, data design documents, and overall operational concepts are still in work and not released. This will require much of the work performed on this project to be reevaluated, as this information becomes available. Though this may seem like a negative, I think it is better characterized as a known risk. To wait until all pertinent documents were officially signed out and in use would mean this work would never get done.

Considering the work that was accomplished on this project, I don't think I would change anything in particular. For the effort expended, there is a lot of useful information captured. However, given additional time I would look into the data flow and format of the various data

types in more detail. Knowing more about the data will potentially point to new or more stringent requirements.

One of the big concerns going into this project was the method of tapping into a fiber optic bus. I have not had much experience with practical applications like an avionics system. Past experience with copper-based avionics busses has shown how seriously adding failure modes to the flight system is taken. With any optical tap, the avionics bus has some non-standard part in-line. If that part were to fail, that leg of the bus goes dark. The combination of the seriousness of the tap and the newness of the technology application will require quite a bit of additional research in this area. Some conversations I've had recently indicate the optical splitters may be passive devices that simply split the optical power in half. I doubt the avionics are being designed to handle a 50% reduction in optical power in case an instrumentation system might be used.

Appendix A

Project Concept

System Engineering Project Concept

Fibre Channel Avionics Bus Monitor

Sid Jones
Fall 2000

Project Objectives

The objective for this project is to rigorously identify the most promising solution for a Fibre Channel Avionics Bus Monitor. Upon completion, the final report may be included in a procurement package or given to vendors in order to gain a commercial product to fill this need.

Need for System

Acquisition Reform has allowed the DoD to quickly integrate state of the art commercial products into the weapons platforms. One such area is the integration of network technology into the avionics suite. There is a concern this is happening faster than the Test and Evaluation community can react with proper instrumentation practices and products.

For the past 20 years, the avionics bus used on military aircraft has been Mil-Std-1553 (1553). Because it utilized a 'bus architecture' where all devices are connected to a central cable, monitoring the bus data for Test & Evaluation purposes was relatively simple. Regardless of where the bus tap was made, all of the data was available. The data requirements of today's aircraft are so large that it overwhelms the 1553 bus. For many applications, the replacement for 1553 is Fibre Channel, an ANSI standard.

Fibre Channel is currently 4000 times faster than 1553 with plans to go faster. Operating at this speed means a bus architecture is no longer feasible. The result is the use of point-to-point architectures. A node on the system will communicate through a port with only one other port. Each node may have multiple ports to create what the industry terms a 'fabric'. The speed and architecture differences between 1553 and Fibre Channel will require the instrumentation community to develop a new approach to capture bus data under this paradigm.

Application of Systems Engineering

The constraints of performing this project during one semester with a team of one, lead me to focus my efforts where I can have the most impact – the concept development stage.

1. Needs Analysis

During needs analysis, the project will be focused on identifying the mission need and translating the need into operational requirements. The requirements will be translated into functions and allocated to subsystems. Operational risk will be addressed in terms of flight safety whenever aircraft production systems may be compromised.

2. Concept Exploration

During concept exploration, the operational requirements will be looked at in more detail ensuring a complete picture independent of any initial design concepts. Performance parameters required to meet the operational requirements will be generated. Multiple system possibilities will be identified

3. Concept Definition

During concept definition, a trade study will be performed to determine the best approach. The selected concept will be analyzed based on the operational requirements to ensure it will meet the need.

Technical Approach

Once the proposal has been accepted, a mission needs statement (MNS) will be written. From the MNS, an operational requirements document (ORD) will be generated. Comments from the three services will be solicited to gain a broad view of the need and requirements. The ORD will be supplemented with a concept of operations (ConOps).

Whenever an instrumentation system interfaces to a critical production system, a flight clearance is needed. Since this will be the first time a networked avionics bus has been monitored, this will be one of the prime elements in the risk analysis. The bulk of this research will identify the office that can grant flight clearances and document what they consider critical. Unlike the needs and requirements, this will be researched within the Navy only in order to limit the scope. It is assumed gaining Navy approval for the system would be similar for the Air Force and Army.

Research into the various possible system configurations will be performed and documented. This document will be the basis for a trade study to determine the most effective solution.

Milestones

Project Start	01 Aug 00
Project Proposal	20 Sep 00
Interim Report	25 Oct 00
Final Report	13 Dec 00
Oral Report	13 Dec 00

System Engineering Project Reclama

1. Requirements

Given that the 1553 has become inadequate for handling data on military aircraft, the question is how much faster should a replacement be to accommodate the data needs for the next 5-10 years. Just because replacement by Fibre Channel is 4000 times faster, this does not drive the requirement.

The airframe manufacturer selected Fibre Channel as the avionics bus based on their needs and insights. My requirement is to capture data on the avionics system without affecting the avionics system. Since Fibre Channel was chosen, that defines one of the external interfaces of the bus monitoring system. The fact that Fibre Channel operates at high speeds imposes additional constraints in how the interface is approached (as opposed to the traditional method of transformer coupling for 1553 bus monitoring).

2. Bus Architecture

If the real requirement for operating speed is well below the maximum speed of Fibre Channel, would bus architecting be feasible? At what speeds does bus architecture become inadequate and why? What are the systems engineering implications of capturing a point-to-point network? How is this more a system than a network design problem?

The discussion of bus architectures was to provide an understanding of some of the fundamental differences between 1553 and Fibre Channel. A 'bus architecture' at gigabit speeds would need to be kept very short due to the propagation delays. (The clock period of a bus operating at 1 GHz is 1 nanosecond. The propagation delay through copper is on the order of 5 nanoseconds per meter.) By the time a test aircraft reaches the instrumentation department for installation of a (developmental test) data acquisition system, the choice of the avionics bus and its architecture has already been decided and installed. Since this bus-monitoring unit would only be used during tests, the option to change the production avionics system is not necessarily available. Below is a graphic showing functionally how the bus monitor system would interface a production avionics system to a T&E data system.

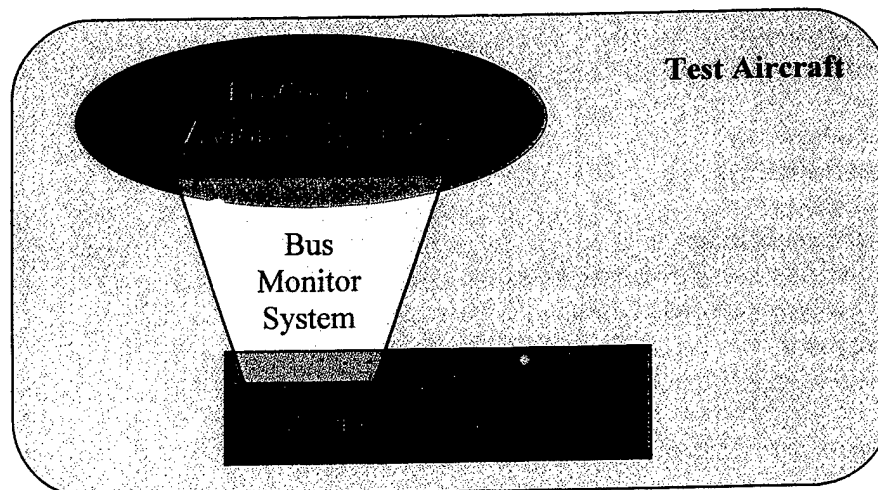

3. In your discussion of Application of System Engineering and Technical Approach, you do not identify the substance of the work but only the generic terms. For instance, what will be the scope of your project in terms of aircraft components? What are examples of typical complex components? What would you trade off? What risks do you anticipate?

The entire bus monitoring system will be flight test components. (see the figure below) There will be data interfaces from the avionics and to the data system. There will also be a format component to format the data into something useful to the data system. There are two major approaches to gathering the avionics data. The first is to monitor each connection from the nodes to the switch. The second is to replace the switch with an instrumentation "friendly" switch. The trade-offs are avionics system integrity, data capture capability, physical size, and commercial viability.

When capturing avionics bus data, there are two modes in which to operate – selected data and 100% data. Selected data is used when a subset of bus data is of concern. One hundred percent data is used when all of the data on the bus is needed or the bus timing is of concern. The avionics interface is considered a complex component. Due to the dual nature of bus data collection and how the data needs to be formatted for each, the formatter is considered a complex component. Since the instrumentation community has control over the T&E data system, the data system interface is not initially considered a complex component.

The first rule of instrumentation is to monitor what is of interest without affecting the measurement. The first rule of flight test instrumentation is to collect the data without adding any critical failure modes to the aircraft (instrumentation failures causing the loss of the aircraft). The major risk to this project is in finding an interface method that won't add any critical failure modes to the aircraft. I don't think that is possible, so the second risk is in identifying someone with signature authority that will allow such a system to be installed. Since the first aircraft with avionics networks haven't reached the T&E ranges yet, this will most likely require a paradigm shift from the way business was done in the past. As a result, a formal process of how to get the chosen interface method approved will be identified.

The scope of the project would be:

- Project need
- Operational requirements
- Risk Assessment
- System concept
 - Functional allocation
 - Avionics bus interface
 - ▲ Requirements
 - ▲ Approach trade-offs
 - Process to get selected interface method approved
 - Format of selected and 100% data
 - ▲ Requirements
 - ▲ Trade-off of using a single format or two tailored formats
 - ▲ Conceptual format based on requirements
- Evaluation of system as defined against the need and requirements

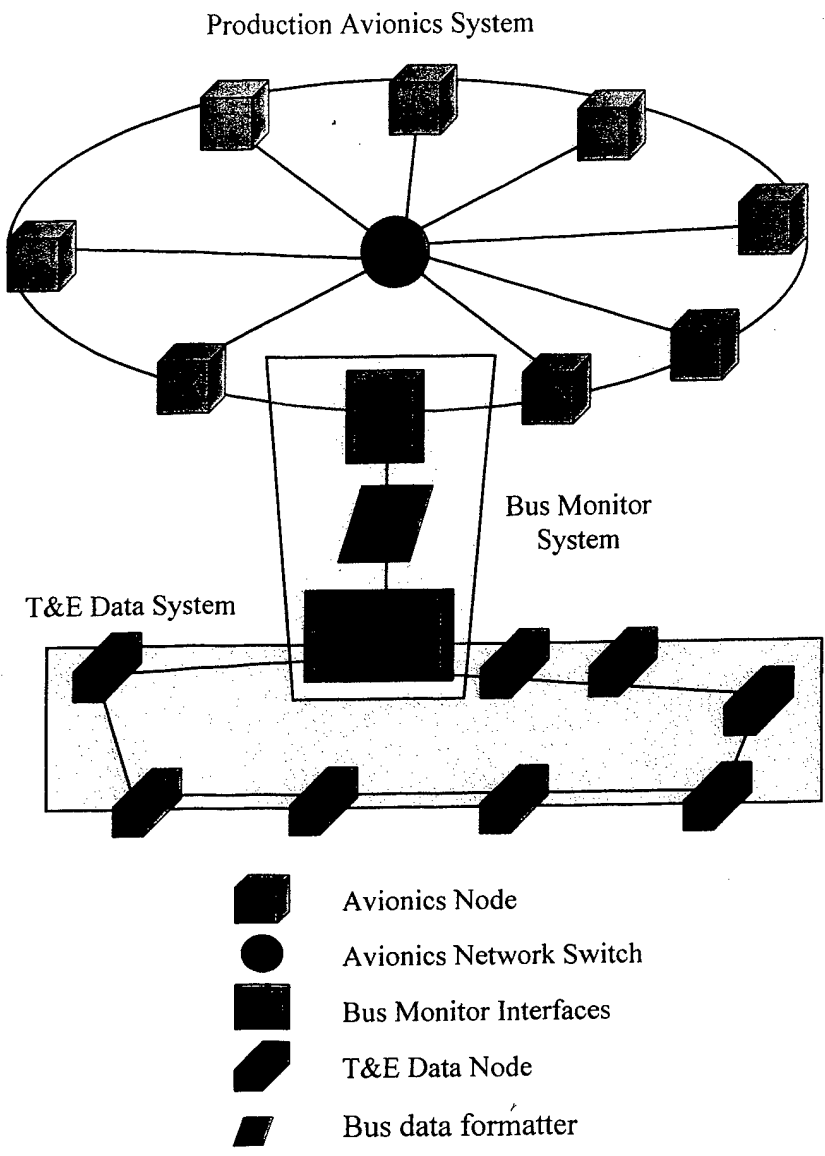

Appendix B

Project Proposal

Fibre Channel Avionics Bus Monitor

Proposal

Johns Hopkins
System Engineering Project

Course No. 645.770

Sid Jones
October 1, 2000

Ray Schulmeyer
Advisor

Project Objectives

Traditionally, airframes were designed without any thought of ways to instrument them. Once the airframe was built, requirements were turned over to the flight test instrumentation department to find a way to monitor the data necessary for testing (the term "afterthought" comes to mind). This was not necessarily a bad thing – then. The economics was a 10 million-dollar instrumentation budget was noise to a billion-dollar development budget. During the past 8-10 years, that has begun to change for a couple of reasons. Defense dollars are diminishing while the airframes are becoming much more complex. The result has been a push-pull effect to integrate the test instrumentation engineers earlier in the program. The developer wants to pull the test instrumentation engineer in to reduce overall development costs. The test instrumentation engineer wants to push their way in to minimize unnecessary instrumentation complexity during Test and Evaluation (T&E).

The current state of the art has airframe developers augmenting the production avionics data buses with high-speed fiber optic networks (in many cases using Fibre Channel). As these fiber optic networks are being installed in airframes, the test instrumentation engineer will be expected to safely monitor the data flowing through them. Unlike many of the systems in the past, successful monitoring will require an engineering analysis way before any data is required. The timing for this project is perfect. Networks are now being put in several of the major airframes where the designs could be tweaked to facilitate the instrumentation system. These systems are far enough down the road that knowledge gained now will help the community prepare.

There is no funding currently identified for this task. The concept was submitted through the Small Business Innovative Research (SBIR) programs office last year, but did not receive funding. Through this project, I expect to lay the groundwork for an avionics bus monitor development program by performing the initial system engineering by developing a system specification. The final report will be cleared for public release to be used as part of a company's Internal Research and Development (IRAD) program or the baseline for a SBIR program.

Need for System

Acquisition Reform has allowed the DoD to quickly integrate state of the art commercial products into the weapons platforms. One such area is the integration of commercial network technology into the production avionics suite. There is a concern this is happening faster than the Test and Evaluation community can react with proper instrumentation practices and products.

For the past 20 years, the avionics bus used on military aircraft has been Mil-Std-1553 (1553). 1553 utilized a 'bus architecture' where all devices are connected to a central cable that made monitoring the bus data for Test & Evaluation purposes relatively simple. Regardless of where the instrumentation system tapped the bus, all of the data was available. Due to the low data rate, the tap was transformer coupled which provided isolation from the instrumentation system.

The data requirements of today's aircraft are so large that it overwhelms the 1553 bus. For many airframe manufacturers, the replacement for 1553 is Fibre Channel, an ANSI standard.¹

Fibre Channel is currently 4000 times faster than 1553 with plans to go faster. Fiber Channel operates in a point-to-point architecture. A node on the system will communicate through its port with only one other port. Special units called 'switches' receive data on one port and send data out on another port to create what the industry terms a 'fabric'. The speed and architecture differences between 1553 and Fibre Channel require the instrumentation community to determine a new approach to capture bus data.

The proposed bus monitor system must be capable of monitoring any data on the production avionics system and direct the data of interest into the T&E data system². See Figure 1. It must do this without compromising the data quality of the avionics system (i.e. affecting the data values or degrading the operation of the bus). A failure of the bus monitor system or the T&E data system should not cause degradation of the production avionics bus.

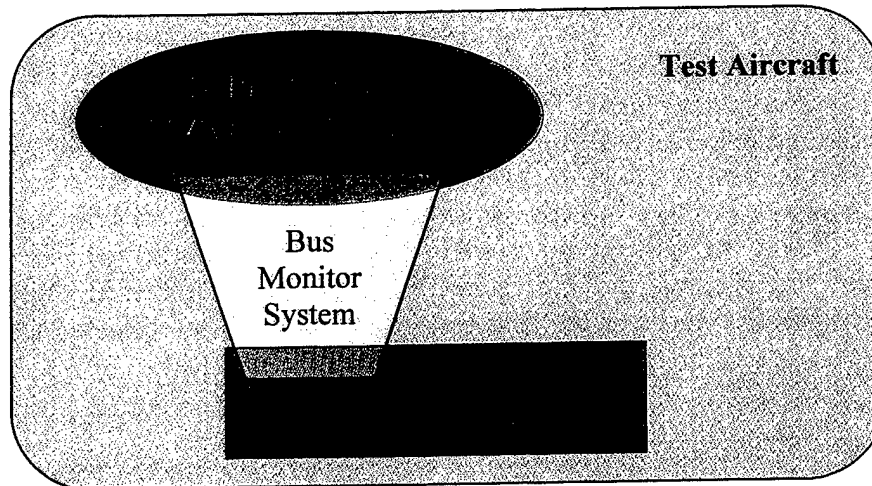

Figure 1 System Relationships

¹ Fibre Channel can utilize either copper wire or fiber optic cables.

² A T&E Data System is a system that monitors data during the T&E development phase. This data is recorded and/or transmitted to a ground processing facility for in-flight data monitoring. As such, the T&E data system cannot interfere with any production systems. The T&E data system consists of independent wiring, data acquisition units, and oftentimes transducers. Upon completion of T&E, the system is removed.

Description of Products

Throughout this project, work will be accomplished on the following deliverables. A rough breakdown of each deliverable is listed below.

Statement of Need

The statement of need will provide background to the problem and address the need for this project with input from the three services.

System Requirements Document

The system requirements document will address the tri-service requirements through questionnaires and several follow-up interviews. A Concept of Operations (ConOps) will be produced to ensure all modes of operation and environments are addressed. Interface Control Documents (ICDs) will be written for the external interfaces and the system and data requirements will be identified. A requirements validation will be performed.

Trade Studies

Two trade studies are planned. The first trade study involves the method of externally 'tapping' into the avionics bus to gather data. Some of the elements that will be traded include – failure modes added to the avionics bus; flight safety approval; commercial availability; and size. Once the test community is comfortable that the avionics bus and T&E data systems are performing as they should, the possibility of being part of the system rather than external to it can be entertained. The second trade study will use the most viable approach(es) from the first trade study and add several alternatives with the data system an integral part of the avionics system.

Interim Report

The Interim Report will provide a detailed snapshot of the project status to date. It will include a detailed project description, the requirements document, a draft of the trade studies, and an updated schedule and risk assessment.

System Specification (A-Spec)

The system specification provides a mechanism to roll much of the initial systems engineering performed on this project into a single concise document. This document will be used as a basis for subsequent contract efforts.

Final Report

The final report is the culmination of the project. Besides final versions of the system engineering tasks performed throughout, it will include the project evaluation and conclusions/recommendations.

Oral Report

The oral report is an hour-long discussion of the project as a whole as well as the lessons learned during the project.

Application of Systems Engineering

The constraints of performing this project during one semester with a team of one, lead me to focus my efforts where I can have the most impact – the concept development stage.

Requirements Analysis

- Develop a statement of need
- Define concept of operations
- Identify Measures of Effectiveness (MOE's)
- Define the system boundaries
- Define the functional and performance requirements
- Validate the requirements

Functional Analysis and Allocation

- Define functional flow block diagram (FFBD)
- Define system data flow diagram
- Define work breakdown structure

Conceptual Design

- Perform feasibility analysis on alternative solutions

Trade-off Studies

- Perform trade study on various methods of externally tapping into the avionics system
 - Individual taps at each node
 - Production switch with instrumentation port(s)
 - Replace production switch with instrumentation switch
- Look at alternatives of tapping into bus externally or become part of the avionics system
 - Use best alternatives from first study
 - Add
 - ▲ Change production software load to direct data to instrumentation port
 - ▲ Require avionics boxes have extra external port

Risk Assessment and Risk Reduction

- Assess operational risk to avionics system
- Assess data risk of introducing errors with monitoring equipment
- Assess program risk of getting approval from 'Flight Safety'

System Evaluation

- Evaluate trade study winner against need and requirements
- Write system spec

Technical Approach and Scope

With the advent of airframe manufacturers using commercial network technology as part of the production avionics system, the instrumentation community has foreseen the need to monitor these new busses. This project will take the gut feeling that something must be done before the aircraft shows up at our doorstep and create a statement of need based on a sampling of users throughout the DoD. The statement of need will guide the development of operational scenarios and requirements.

Whenever an instrumentation system interfaces to a critical production system, a flight clearance is needed. Since this will be the first time a networked avionics bus has been monitored, flight clearance issues will be the prime element in the operational risk analysis. The bulk of this research will identify the office that can grant flight clearances and document what they consider critical. Unlike the needs and requirements, this will be researched within the Navy only in order to limit the scope. It is assumed the process to gain Navy approval for the system would be similar for the Air Force and Army.

There are two reasons to gather data from the production avionics bus. The first is when you are validating the bus -- you want to make sure the data on the bus is correct. In this case, the data system must be independent of the avionics system. The first trade study will consider the options available in this scenario. The second reason to gather bus data is when the data is needed as truth data. The bus data is used to validate a separate subsystem. The independence of the data system is less critical in this case. Once airframes are validated, this is the long-term case. The second trade study will consider all ways of gathering data from the bus including the best cases from the first trade study and situations where the data system is part of the avionics system. The trade elements will be slightly different in the second study. While the first will focus mostly on getting the job done, the second will focus more on the long-term costs.

The system engineering products produced during this project will be included by reference or attachment in the system specification. The system specification will be the basis for follow on funding avenues.

Resource Requirements

- Standard office equipment (computer w/ internet access, desk, phone)
- ANSI Fibre Channel standards
- Access to Fibre Channel Avionics Personnel
 - Primarily Fibre Channel Avionics Environment Working Group
 - Mike Foster, Boeing - Seattle
 - Steve Wilson, Boeing - St. Louis
 - Bob Pederson, General Dynamics
 - Gary Warden, SRB Consulting
- Access to Flight Safety Personnel
- Access to advisor
- Access to user community
 - Tim Chalfant, Edwards AFB
 - Kip Temple, Edwards AFB
 - Rob Crist, Eglin AFB
 - Dan Skelley, Naval Air Warfare Center
 - Sam Marderness, Aberdeen Proving Grounds
- Time

Task Breakdown

Fibre Channel Avionics Bus Monitor

1. Write Concept
2. Write Proposal
3. Needs analysis
 - 3.1. Evaluate current state of the art avionics bus architectures
 - 3.2. Poll user groups
 - 3.3. Write statement of need
4. Requirements Analysis
 - 4.1. Concept of Operations
 - 4.1.1. Define Operational Scenarios
 - 4.1.2. Define the Boundaries of the System
 - 4.1.3. Write concept of operations
 - 4.2. Identify external interfaces and write appropriate interface control documents
 - 4.3. Gather data
 - 4.3.1. Write questionnaire and conduct interviews
 - 4.3.2. Reduce data
 - 4.4. Identify/document process to get selected interface method approved
 - 4.5. Identify system requirements
 - 4.6. Identify data requirements
 - 4.7. Write requirements document
5. Trade Studies
 - 5.1. Bus tapping method
 - 5.1.1. Establish criteria
 - 5.1.2. Identify possible methods
 - 5.1.3. Research each method
 - 5.1.4. Write document
 - 5.2. Avionics data acquisition approach
 - 5.2.1. Establish criteria
 - 5.2.2. Identify possible methods
 - 5.2.3. Research each method
 - 5.2.4. Write document
6. Interim Report
7. System Spec
 - 7.1. Create document outline
 - 7.2. Write document scope and system overview
 - 7.3. Write system requirements section
 - 7.4. Finalize document
 - 7.5. Update Needs/Requirements documents
8. Final Report
9. Oral Report

Milestones and Schedule

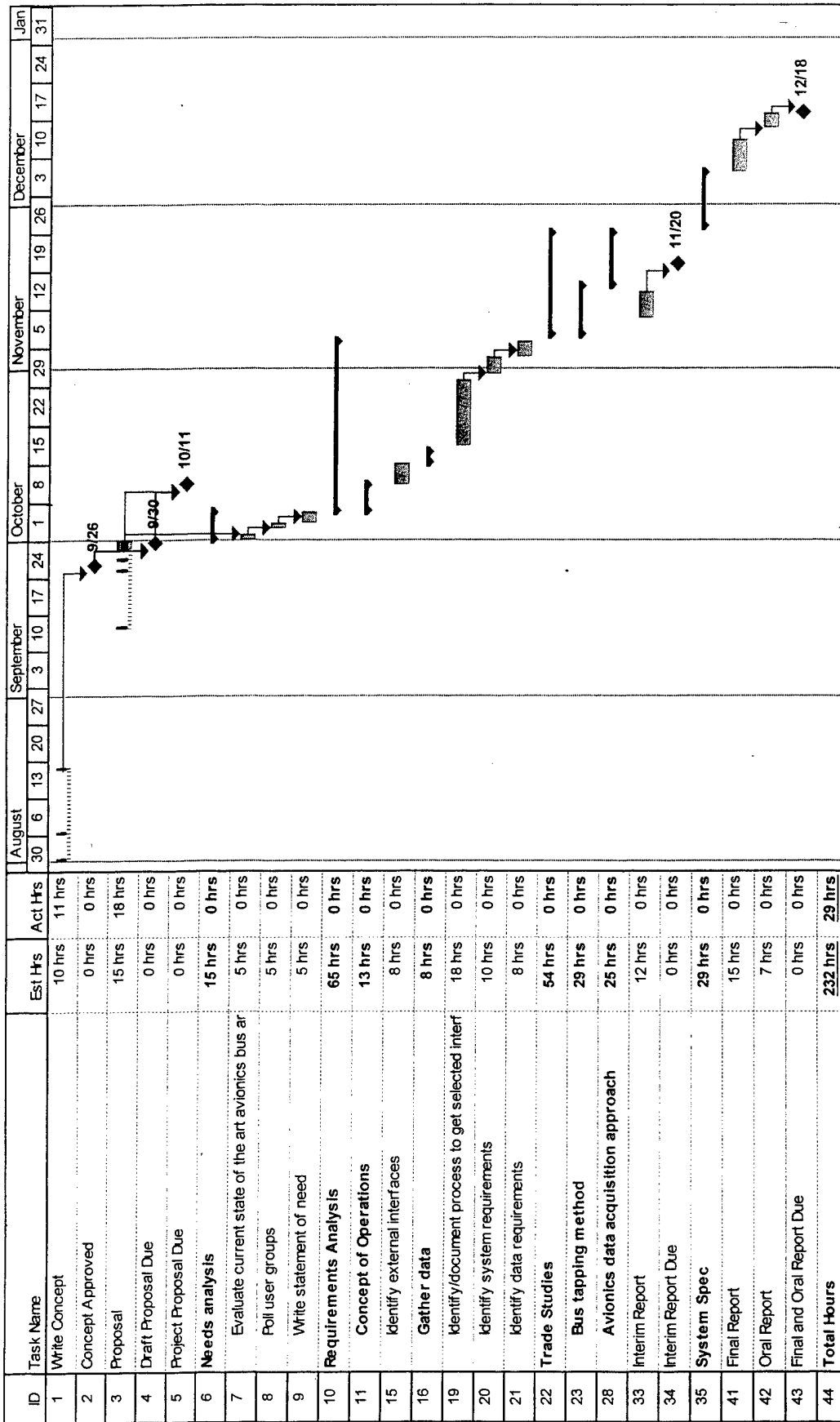

Risk Assessment

		Prob	Severity
Risk	Interacting with new advisor	Low	Med
Mitigator	Face to face meeting; email/phone communication		
Status	Open		
Risk	Not meeting user's needs and requirements	Med	High
Mitigator	Interview users, provide draft documents to users for feedback		
Status	Open		
Risk	Not understanding operational environment	Med	Med
Mitigator	Use previous bus monitors (1553) as a model, talk to knowledgeable people.		
Status	Open		
Risk	Not understanding network aspect of avionics	High	High
Mitigator	Get knowledgeable people involved (fibre channel and avionics). Do research.		
Status	Open		
Risk	Trade Study: Don't include viable option or don't throw out non-viable option	High	Med
Mitigator	Get knowledgeable people involved (fibre channel and avionics). Do research.		
Status	Open		
Risk	Fall behind on schedule due to workload, travel, family	Med	Low
Mitigator	Produce realistic schedule. Work to get ahead when possible. Identify critical path.		
Status	Open		
Risk	Unknown - unknowns	Med	High
Mitigator	Perform risk assessment periodically. Keep looking for potential risk areas		
Status	Open		

Appendix C

Statement of Need

Fibre Channel Avionics Bus Monitor

Statement of Need

Johns Hopkins
System Engineering Project

Course No. 645.770

Sid Jones
October 30, 2000

Ray Schulmeyer
Advisor

Scope

This statement of need is concerned with the Test and Evaluation (T&E) organizations' need to monitor data from the production avionics busses on various weapons platforms. The requirements for monitoring bus data change throughout the life of the platform as the nature of the tests change from validating the bus to using the bus as a truth source. The need will be considered from the perspective of the weapons platform lifecycle.

Background

A T&E Data System acquires data during a test or mission. This data is recorded for post-flight analysis. The data may also be transmitted to a ground processing facility for in-flight data monitoring. As such, the T&E data system must be invisible to the operation and control of the aircraft. The T&E data system typically consists of independent wiring, data acquisition units, and oftentimes transducers. Upon completion of T&E, the system is removed and the aircraft is returned to fleet status. The data system may also be known as an instrumentation system or a telemetry system.

For the past 20 years, the avionics bus used on military aircraft has been Mil-Std-1553 (1553). Much of the data sent across the 1553 bus is of interest to the test program. As can be seen in **Figure 1**, a bridging system was used that would gather the data of interest from the production avionics system and format the data into something useful for the T&E data system.

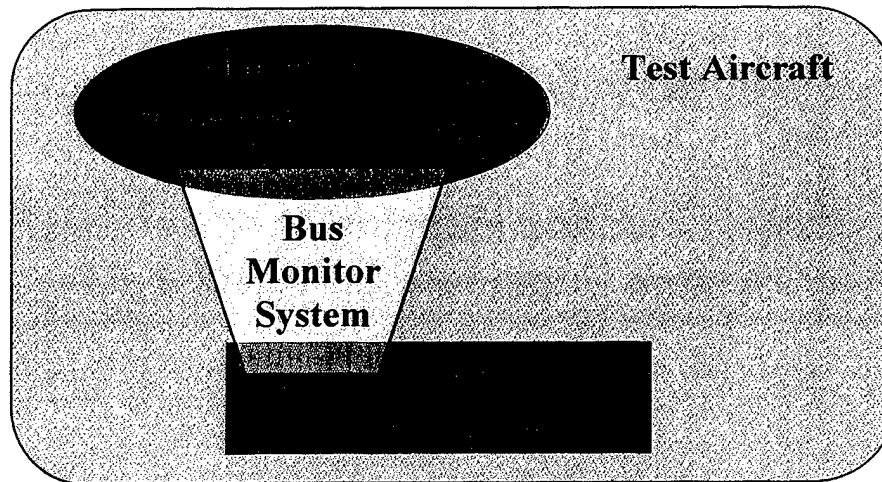

Figure 1 System Relationships

The 1553 standard utilizes a 'bus architecture' where all devices or remote terminals (RT) are connected to the bus controller (BC) via a central cable as shown in Figure 2. Regardless of where a unit is connected to the bus, all of the data on the bus is available to the unit. To interface to the 1553 bus, the bus monitor system used the same method listed in Mil-Std-1553 that the avionics units followed. The bus monitor was programmed to capture all of the data (100% mode) or specific data words (selected data mode).

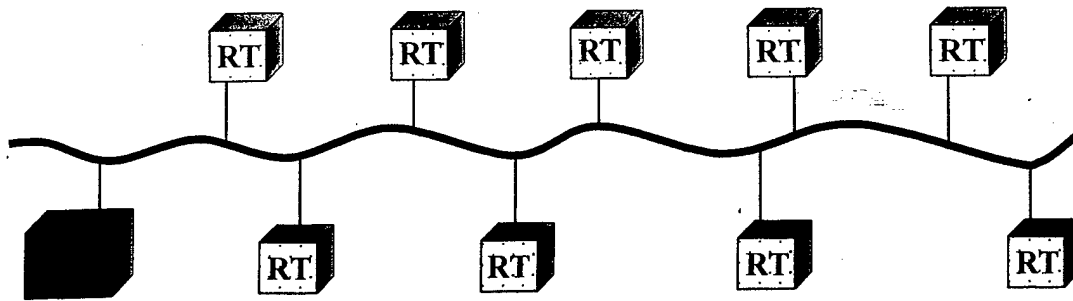

Figure 2, 1553 Bus Architecture

Basis for Need

Acquisition Reform has allowed the Department of Defense (DoD) to quickly integrate state of the art commercial products into weapons platforms. One such area is the integration of commercial network technology into the production avionics suite. The current state of the art has airframe developers augmenting the production avionics data buses with high-speed fiber optic networks (in many cases using Fibre Channel¹). Fibre Channel is currently 4000 times faster than 1553 (4 Gbps vs 1 Mbps) with current plans to go to 10 Gbps. Fibre Channel operates in a point-to-point architecture as shown in Figure 3. A node on the system will communicate through its port with only one other port. Special units called 'switches' receive data on one port and send data out on other ports to create what the industry terms a 'fabric'.

T&E organizations currently have minimal experience with fiber optic network busses. When questioned, they expect their current systems to be inadequate for the higher speeds and architectural differences found in Fibre Channel designs. They also expect bus monitor systems for these busses to be significantly different from current practices and that a significant safety review of the installation design will be necessary.

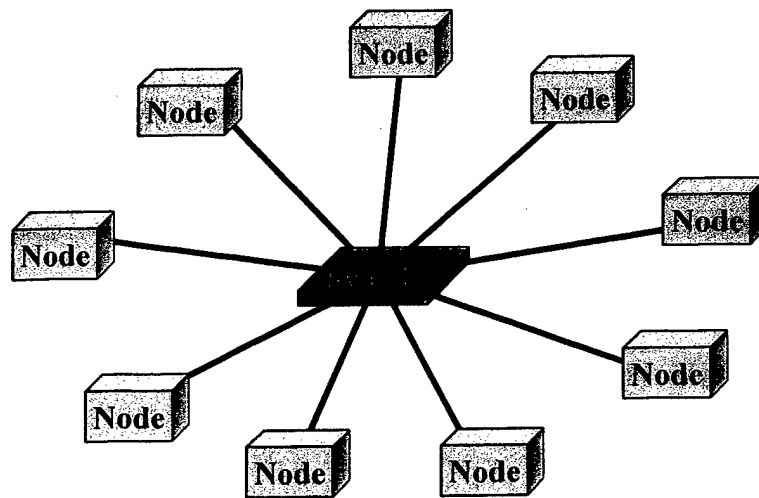

Figure 3, Fibre Channel Switched Fabric Architecture

¹ Fibre Channel is an ANSI standard that can utilize either copper wire or fiber optic cables.

Deficiencies in Current Bus Monitor Systems

The move to network based, fiber optic avionics busses highlight several deficiencies in the current bus monitor systems being used for 1553. These deficiencies are of such magnitude that merely upgrading the tools will not be enough. A new approach must be devised from the ground up.

The easiest deficiencies to grasp are the speed and cabling plant differences. 1553 operates at a signaling rate of 1MHz. The Fibre Channel rate that most systems use is 1 GHz – 3 orders of magnitude higher. The Fibre Channel specification currently tops out at 4.25 GHz with plans in work for 10 GHz. These speed differences alone invalidate the use of transformer coupling like that currently used. Because Fibre Channel has its sights set on 10 GHz (and most likely higher over time), most of the manufacturers are installing fiber optic cabling from the outset. Copper wire can be used at 1 GHz for moderate length runs. As the rate rises, the copper runs get shorter and require more attention to impedance matching issues.

One of the more difficult issues to grasp is the concept of a layered architecture. To put it simply, a layered architecture breaks up the system into distinct components. Provided the interface between the components is adhered to, an individual layer can be easily substituted with a layer of similar qualities to meet the current need. Most systems prior to the network revolution used monolithic models. They described everything from the way the data was formatted to the encoding of the electrical signal on the bus. To try a simple analogy, consider the differences between a 3-bean soup recipe vice a 3-bean soup kit (just add water). See Table 1. Current 1553 bus monitors were designed around a monolithic 1553 specification. Given the major differences in data rate and format, the bus monitors can not be cost-effectively upgraded.

Table 1, Layered Model Analogy

	Recipe (Layered Model)	Kit (Monolithic Model)
Meeting your needs	Tailor recipe to your tastes or needs	May have to adjust your tastes to the kit
Availability	Without agreements of how to tailor, may not get it anywhere but home	The same thing every time regardless of who made it or where
If one ingredient is high priced or unavailable	Substitute for another ingredient	Kit is high priced or unavailable

Non-materiel Alternatives

There are no non-materiel alternatives considered to be adequate. The following are alternatives that were considered.

Ignore the bus, acquire data from other means

The data on the bus falls into two categories – internal and external avionics data. The external data could be acquired by installing transducers throughout the aircraft. For some tests this would be preferable. However in general, it would increase the long term cost in both dollars and down time of the test asset through duplicating many of the data sources already on the bus.

Internal data by definition comes from internal to the avionics system. Many of these data are calculated variables, status fields and the like. The only source of this data is the avionics system itself. Without the bus, specific I/O would need to be included in the design of all avionics units just for T&E purposes. The cost would be prohibitive even if the T&E community could drive the requirements of a major acquisition program.

Use the same methods as the manufacturers when the platform was originally designed

This is a viable alternative in theory, but with two strikes against it. The first is that each manufacturer is concerned with that particular platform. They are not looking at requirements across the entire DoD inventory. They need to be price-competitive therefore focus their efforts on the requirements of that particular platform. The second strike is their requirements are focused with the initial sale of the platform. The T&E organizations need to look across the lifecycle of each platform. Timeliness of what the manufacturers' are doing compounds the problem. Until the contract is awarded, many new platforms consider the avionics design a competitive advantage. This makes getting information difficult in the early stages of design.

Choosing this alternative at face value is not considered adequate. This alternative may require a different approach for each platform and leaves too much to chance that general T&E needs will be met. However, each of the manufacturer's methods will be considered during the later phases of the project.

Potential Materiel Alternatives

Military Programs

Military & Aerospace Electronics Magazine reported that Fibre Channel is part of the design baseline for avionics upgrades in the F/A-18, AH-64, B-1, and the AWACS. Fibre Channel is reportedly being considered for the Joint Airborne SIGINT and the Joint Strike Fighter. It is expected that each of these programs will be able to monitor Fibre Channel to some degree depending on the depth of the avionics upgrade/design and their own requirements. The specifics of these approaches should be evaluated as potential solutions to this need.

Vendors

As a result of the programs mentioned previously, it is expected the majority will contract the effort to one or more vendors. The following companies should be researched for possible solutions based on military program requirements, commercial requirements, and in-house developments. This list would include:

- **Avionics component vendors**
 - DY-4 Systems, Inc
 - Data Device Corp.
 - SBS Technologies, Inc
 - Systran Corporation
- **Instrumentation vendors**
 - L-3 Communications
 - Metraplex
 - SCI Systems
 - Teletronics.
- **Commercial Fibre Channel vendors**
 - Adaptec
 - Agilent Technologies
 - Ancot
 - Brocade Communications
 - Emulex Network Systems
 - Gadzoox Networks
 - McData Corporation
 - Qlogic
 - Vixel Corporation
 - Xyratex

Inter-Service Cooperation

Fibre Channel will be useful whenever an avionics bus must deal with volumes of data like imagery, radar, and sonar. This need is therefore not limited to any one service or any one-platform type. This need is shared by all three services and should be coordinated as such.

Potential Areas of Study

The single largest obstacle appears to be the method of tapping into the avionics fiber optic cable without adding undue failure modes. Future study should focus on this area or alternate means that don't require a fiber optic tap. Other potential areas include

- Modifying all production avionics switches to allow test systems to easily acquire bus data.
- Modifying some production avionics switches that are used in place of the production switch during testing.
- Develop/purchase test-only switches that are used in place of the production switch during testing.
- Programming the avionics software to send data to a pre-selected instrumentation address.
- Requiring duplicate ports on each avionics unit for test purposes.

Constraints

Bus monitor systems provide two basic functions through the life of a test platform. During the development and testing of major bus modifications, the bus monitor system captures the state of the bus for bus validation purposes. It provides information about what the platform thinks is going to happen. This data is correlated against other known sources. When testing small system updates or additions, the bus monitor is a cost-effective source of "truth" data from many systems throughout the platform. A solution or solutions must take both of these functions into account.

Acquisition reform and the use of commercial-off-the-shelf (COTS) have required users take a hard look at the true environmental requirements. For many systems, the use of COTS products have provided cost-effective solutions. This system must operate in an airborne uninhabited fighter environment. Packaging and environmental issues must be considered for any solution.

The goal of a test system is to acquire the data of interest without affecting the system under test. When dealing with avionics systems this is especially true. Compromising the avionics bus could cause a critical failure. Currently, 1553 bus monitor systems use a passive bus coupler to acquire the data from the bus. Given the high data rates and the use of fiber optics, the requirement for an active coupler is a distinct possibility. Active couplers significantly increase the risk of additional failure modes for the avionics bus. Flight safety will be a critical constraint of any approach considered.

Network technology has been around for years. Larger budgets in the past have allowed the T&E community to remain inwardly focused by creating their own standards. By controlling the standards, they created a stable platform environment. With budgets on the decrease, more pressure to utilize commercial products, and now networked based avionics busses, the T&E community can no longer avoid the network issue. There is a small number of T&E personnel that see many benefits with the use of networks. These people are raising awareness of T&E network issues -- both promises and problems. The concern is that few people with a

respectable knowledge of T&E data systems have more than a casual knowledge of networks and how to apply it. This small cadre of network-knowledgeable people is the ones that must judge the merits of a bus monitor approach. What makes this difficult, is these people are not easy to find. They are not necessarily T&E personnel, heads of organizations, 'gray beards', or young techno-junkies.

References

There are four major T&E Ranges where the majority of avionics bus testing is accomplished: Naval Air Warfare Center (Patuxent River and China Lake), Edwards Air Force Base, and Eglin Air Force Base. The following people were contacted for input to this document since they were in positions that allowed them a longer-term view. Validation of this need is expected to exceed this initial group.

- Rob Crist, Supervisor, F15 Systems Engineering of the Instrumentation Division, Eglin AFB
- Dan Skelley, Deputy Director, Test Article Preparation. Naval Air Warfare Center
- Tim Chalfant, Chief, Instrumentation development branch, Edwards Air Force Base

Appendix D

Operational Concept Document

Fibre Channel Avionics Bus Monitor

Operational Concept Document

Johns Hopkins
System Engineering Project

Course No. 645.770

Sid Jones
October 30, 2000

Ray Schulmeyer
Advisor

Table of Contents

1	SCOPE	1
1.1	SYSTEM OVERVIEW.....	1
1.2	DOCUMENT OVERVIEW.....	1
2	REFERENCED DOCUMENTS	1
2.1	PROJECT DOCUMENTS.....	1
2.2	INTERFACE DOCUMENTS.....	1
3	CURRENT SYSTEM OR SITUATION	2
3.1	BACKGROUND, OBJECTIVES, AND SCOPE.....	2
3.2	OPERATIONAL POLICIES AND CONSTRAINTS.....	3
3.3	DESCRIPTION OF CURRENT SYSTEM.....	3
3.4	USERS OR INVOLVED PERSONNEL	5
3.5	SUPPORT CONCEPT.....	6
4	JUSTIFICATION FOR AND NATURE OF CHANGES.....	6
4.1	JUSTIFICATION FOR CHANGE.....	6
4.2	DESCRIPTION OF NEEDED CHANGES	6
4.3	PRIORITIES AMONG THE CHANGES.....	6
4.4	CHANGES CONSIDERED BUT NOT INCLUDED	7
4.5	ASSUMPTIONS AND CONSTRAINTS	7
5	CONCEPT FOR NEW OR MODIFIED SYSTEM	7
5.1	BACKGROUND, OBJECTIVES, AND SCOPE.....	7
5.2	OPERATIONAL POLICIES AND CONSTRAINTS	8
5.3	DESCRIPTION OF CURRENT SYSTEM.....	8
5.4	USERS OR INVOLVED PERSONNEL	10
5.5	SUPPORT CONCEPT.....	11
6	OPERATIONAL SCENARIOS.....	11
6.1	INSTALLATION	11
6.2	SYSTEM SETUP.....	12
6.3	DATA ACQUISITION DURING AVIONICS BUS VALIDATION	12
6.4	DATA ACQUISITION WITH AVIONICS BUS AS TRUTH DATA SOURCE.....	13
7	SUMMARY OF IMPACTS.....	13
7.1	OPERATIONAL IMPACTS	13
7.2	ORGANIZATIONAL IMPACTS	14
7.3	IMPACTS DURING DEVELOPMENT	14
8	NOTES.....	15
8.1	FIBRE CHANNEL INTRODUCTION.....	15
8.2	ACRONYMS & ABBREVIATIONS	18
8.3	FIBRE CHANNEL REFERENCE MATERIAL.....	19

1 Scope

1.1 System Overview

This document pertains to a proposed Fibre Channel Bus Monitor. This bus monitor is used to monitor Fibre Channel avionics busses located on weapons platforms for test and evaluation (T&E) purposes – primarily during developmental testing.

Currently most weapons platform avionics busses use Mil-Std-1553 (1553). 1553 is a military standard that was developed in the 1970's. It has worked exceptionally well and won't be completely replaced for a long time. However, at a signaling rate of 1 MHz, it is showing its age. Fibre Channel is a commercial standard having a much larger bandwidth than 1553 (1000x). Many avionics system designers are upgrading their avionics systems to include Fibre Channel support for data intensive sensors like radars, infrared, and video.

1.2 Document Overview

The purpose of this document is to describe the state of current systems, the concept envisioned for the new system, how the new system will be used, and the impacts it may have on current operating procedures.

2 Referenced Documents

2.1 Project Documents

Fibre Channel Avionics Bus Monitor Proposal, October 1, 2000

Fibre Channel Avionics Bus Monitor Statement of Need, October 30, 2000

2.2 Interface Documents

Mil-Std-1553B NOT 4	Aircraft Internal Time Division Command/Response Multiplex Data Bus, 15-Jan-96
A00.00-C001B	CAIS Bus Interface Standard, 10-Sep-99
IRIG Standard 106-00	Telemetry Standards, January 2000
ANSI X3.230-1994	Information Technology - Fibre Channel Physical and Signaling Interface (FC-PH), 1994
ANSI X3.297-1997	Information Technology - Fibre Channel Physical and Signaling Interface - 2 (FC-PH-2), 1997
ANSI X3.303-1998	Information Technology - Fibre Channel Physical and Signaling Interface - 3 (FC-PH-3), 1998
ANSI X3.272-1996	Information Technology - Fibre Channel Arbitrated Loop (FC-AL), 1996
ANSI X3.nnn-200x	Fibre Channel Avionics Environment Technical Report (due 12/00)
ANSI X3.nnn-200x*	Information Technology – Fibre Channel – Physical Interfaces (FC-PI)
ANSI X3.nnn-200x*	Information Technology – Fibre Channel – Framing and Signaling (FC-FS)

* FC-PI and FC-FS are currently in work and will supersede FC-PH, FC-PH-2, and FC-PH-3

3 Current System or Situation

3.1 Background, Objectives, and Scope

A T&E Data System acquires data during a test or mission. This data is recorded for post-flight analysis. The data may also be transmitted to a ground processing facility for in-flight data monitoring. As such, the T&E data system must be invisible to the operation and control of the aircraft. The T&E data system typically consists of independent wiring, data acquisition units, and oftentimes transducers. Upon completion of T&E, the system is removed and the aircraft is returned to fleet status. The data system may also be known as an instrumentation system or a telemetry system.

For the past 20 years, the avionics bus used on military aircraft has been Mil-Std-1553 (1553). Much of the data sent across the 1553 bus is of interest to the test program. As can be seen in Figure 1, a bridging system was used that would gather the data of interest from the production avionics system and format the data into something useful for the T&E data system.

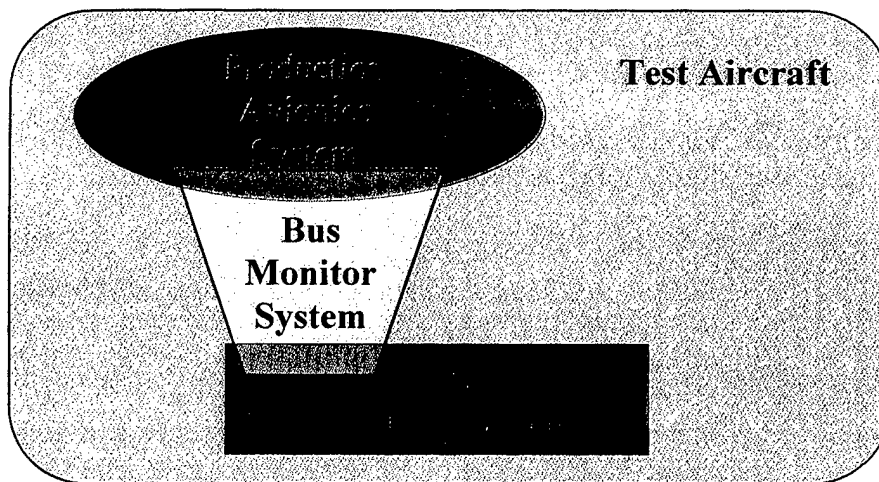

Figure 1 System Relationships

1553 utilizes a 'bus architecture' where all devices or remote terminals (RT) are connected to the bus controller (BC) via a central cable as shown in Figure 2. Regardless of where a unit is connected to the bus, all of the data on the bus is available to the unit. To interface to the 1553 bus, the bus monitor system used the same method listed in Mil-Std-1553 that the avionics units followed. The bus monitor was programmed to capture all of the data (100% mode) or specific data words (selected data mode).

Bus monitor systems are usually part of a larger T&E data system. The T&E data system is installed on the test vehicle to gather data describing the state of the test vehicle at any given moment. The data system will gather data from many different systems including both production and test systems. The avionics bus monitor is but one data source. The data is transmitted, recorded or both.

The most common military avionics bus monitored by the T&E community is Mil-Std-1553 (1553). Current 1553 bus monitor systems acquire the data of interest on the 1553 bus and pass it on to the T&E data system. The objective of the 1553 bus monitor is to monitor the 1553 data without compromising the integrity of the avionics bus. A typical 1553 bus monitor system includes the bus tap (the 1553 avionics interface), the central unit where the data is formatted, the program is stored, and the data system interface is located. (reference Figure 2)

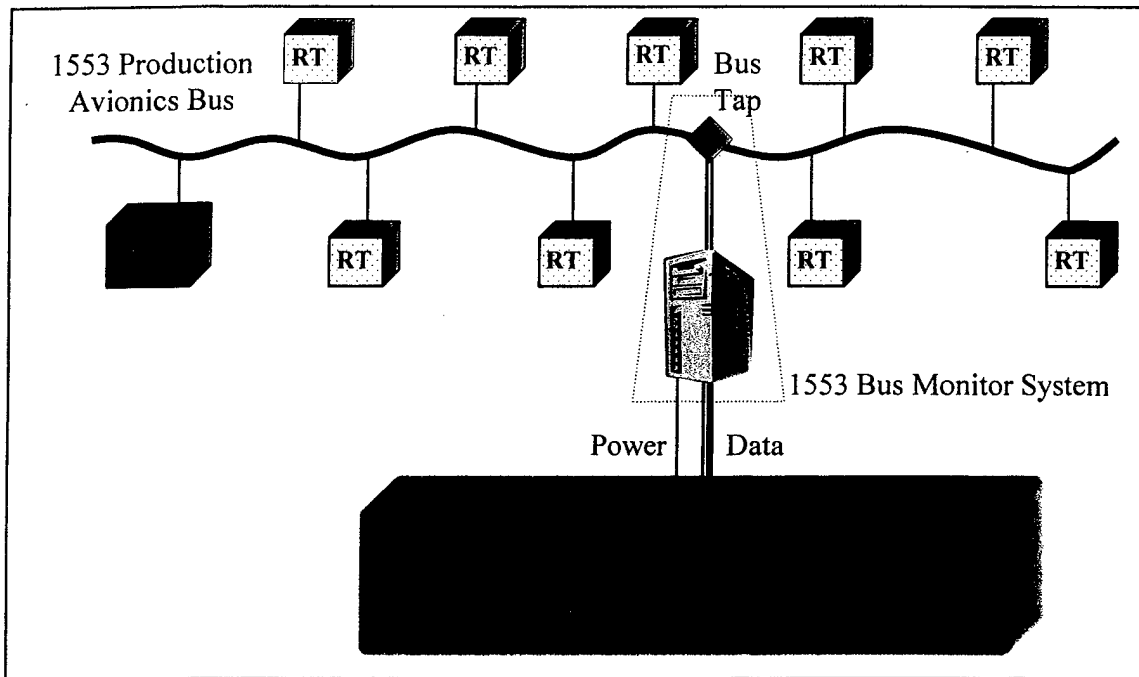

Figure 2 1553 Bus Monitor System Context

3.2 Operational Policies and Constraints

Although there are always exceptions, in general, the 1553 bus monitor must adhere to the following constraints

- Must adhere to the 1553 standard in a receive only mode.
- Must not interfere with normal operation of the 1553 bus.
- Must not introduce additional failure modes

3.3 Description of Current System

3.3.1 Operational Environment

The system operates in an airborne uninhabited fighter environment. This implies a rugged environment with tolerances toward higher shock, vibration, temperature extremes, humidity, etc. Its use on test vehicles requires a small volume to allow installation in space constrained environments.

3.3.2 Major System Components

The physical configuration between manufacturers of 1553 bus monitors may vary. However, in general they are fairly consistent with two main components. The two components are depicted in Figure 2.

- **1553 Interface(s)** also known as **1553 bus taps**. A test article may have one or more 1553 busses. Some systems have as high as 14. Depending on the test, not all 1553 busses may need to be monitored.
- **Central Unit**. The central unit performs four main functions. The pre-programmed instructions of what data is of interest is stored during system setup. During operation, the bus data being received across the 1553 interface is compared to the instruction set stored in memory. The data that is of interest is formatted into a message that is transmitted across the data system interface to the data system.
 - *Program storage* – Memory to which the user uploads operational instructions.
 - *Data comparator* – Compares incoming data messages to instructions in program storage.
 - *Data Message Formatter*. – Formats selected data into a data system message structure.
 - *Data system interface* – Physical interface into the data system.
- **Programming Software**. This software may be a standalone program or a part of the overall data system software. The software provides an interface that allows the user to select the data of interest. The software uploads the instructions into the program storage memory via the data system interface.

3.3.3 Interfaces to External Systems or Procedures

There are two major external interfaces. They are the 1553 bus interface and the data system interface. The 1553 interface is controlled by Mil-Std-1553. Many times these bus monitor systems are part of a bigger data system that was developed by a single vendor and may be proprietary. In recent years, the Common Airborne Instrumentation System (CAIS) bus has tried to change this situation by establishing the CAIS Bus Interface Standard. For these data systems, the CAIS Bus Interface Standard controls the data system interface.

As stated previously, these systems need to be programmed before they are useful – as is the case with most data system components. Many of the data systems require some coordination between the bus monitor system and the data system controller (DSC). In these systems, the bus monitor will acquire the data according to its program load and store the values in memory. When the system controller is ready for the data, it will query specific addresses in the bus monitor. The majority of bus monitors are sub-systems to larger data systems. The hand-off of data addresses in the bus monitor to the DSC is handled by a single integrated software program.

3.3.4 Capabilities/Functions of the Current System

Current 1553 bus monitor systems operate in two modes: Selected Data Acquisition and 100% Bus Capture. These modes typically operate independent of each other, mostly due to bandwidth issues. Figure 3 shows a typical data system. Whereas a single bus monitor can interface up to 8 1553 busses, one is shown in the figure for simplicity. The 1553 bus monitor system (BMS) monitors the data flowing through the 1553 production avionics system. According to the program stored in the 1553 BMS, selected data is stored in memory. If 100% acquisition is enabled, the 1553 BMS also formats the entire 1553 bus data stream and outputs it directly to the recorder. The Data System Controller (DSC) queries all of the data acquisition units for specific

data according to its programmed instructions. The DSC formats this data and sends it to the recording system and the transmitter system. Due to telemetry bandwidth constraints, this selected data output is usually a much lower rate than the 100% 1553 output (1 Mbps vs 16 Mbps for 100% of 8 1553 busses).

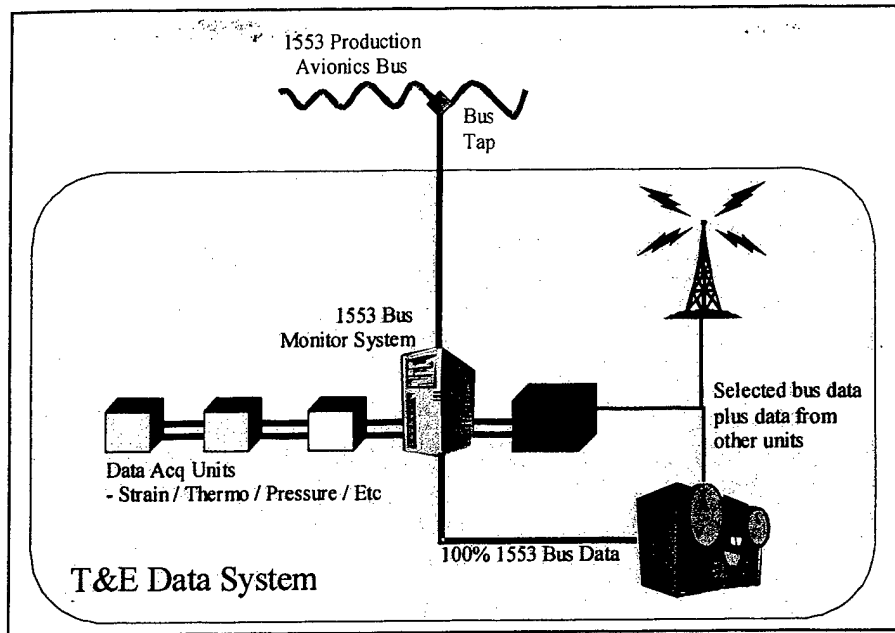

Figure 3 Typical Data System

3.4 Users or Involved Personnel

There are four types of users involved with operating this product. In some organizations, a single individual could accomplish more than one function. For each of these user types, organizations may require additional coordination or oversight. For example, a system installer may require structural approvals prior to installation and inspection prior to flight.

- **Instrumentation Engineer** – This person understands the technical details of the capabilities of this system and how they relate to the requirements the data system must fulfill overall. This person is responsible for programming the system to obtain the desired performance. This person is also involved with the installation of the BMS insofar as where it will be located and what wiring needs to be run to support it.
- **System Installer** – This person physically installs the unit into the test article in the location the engineer has identified. This person has direct knowledge (or a support structure) of structures and mechanical design to ensure the BMS is installed in a safe manner relative to the vehicle's environment to which it is installed.
- **Cable Installer** – This person physically installs the wiring as identified by the engineer. This person has the knowledge of how to properly route and constrain the wire runs throughout a given test vehicle.
- **Test Operator** – The test operator is the person actually performing the test. Dependent upon the type of test, this could be a pilot, driver, or lab technician. This person has no detailed knowledge of the BMS or its capabilities. The extent of operator involvement is limited to an overall data system power switch.

3.5 Support Concept

The details of the support concept employed by each organization vary. This is based largely on how they are funded, the number of systems fielded on daily, monthly or annual basis, and their relationship with their customer. What is common is the fact that BMS are commercial products. Any repairs or replacements are handled directly with the factory. This implies that each organization have some contract mechanism available to reach that particular vendor.

4 Justification for and Nature of Changes

4.1 Justification for Change

The move to network based, fiber optic avionics busses highlight several deficiencies in the current bus monitor systems being used for 1553. These deficiencies are of such magnitude that merely upgrading the tools will not be enough. A new approach must be devised from the ground up.

The easiest deficiencies to grasp are the speed and cabling plant differences. 1553 operates at a signaling rate of 1MHz. The Fibre Channel rate that most systems are considering as a baseline is 1 GHz – 3 orders of magnitude higher. The Fibre Channel specification currently tops out at 4.25 GHz with plans in work for 10 GHz. These speed differences alone invalidate the use of transformer coupling like that currently used. Because Fibre Channel has its sights set on 10 GHz (and most likely higher over time), most of the manufacturers are installing fiber optic cabling from the outset. Copper wire can be used at 1 GHz for moderate length runs. However, as the rate rises, the copper runs get shorter and require more attention to impedance matching issues.

The bus topology has significantly changed with Fibre Channel. 1553 used a bus topology. All traffic was sent across a media who was common to all terminals. A single 1553 tap could monitor all of the data on the bus. The Fibre Channel topology is called a switched Fabric (reference section 8.1.2 for additional information). With a switched Fabric, a node will send its information to the switch; the switch in turn sends the data to the appropriate node based on the address of the data packet. With Fibre Channel operating at such high speeds, the probability of running fiber optic cables, and a different bus topology, the old method of tapping into a bus will not work. The question of how to tap into the bus will require a lot of thought as to what can be done and a lot of discussion as to what should be done.

4.2 Description of Needed Changes

Given the deficiencies listed in 4.1, an approach to monitor Fibre Channel avionics busses must be devised. The approach will consist of a method to electrically (optically) interface to the avionics bus and provide the necessary data to satisfy the performing organization's flight safety requirements. The approach must satisfy the operational scenarios listed in section 6 while minimizing any failure modes added to the avionics bus as a result of the interface method.

4.3 Priorities Among the Changes

- The first priority is flight safety. Any approach must be considered 'safe'. Safe in this case is defined as having no undue level of risk. Each organization must address acceptable risk in their own terms according to their mission, experience, and capabilities.

- The second priority is data integrity. Data that is corrupted by the test system is of no value.
- The third priority is a tradeoff between capability and cost.

4.4 Changes Considered but not Included

There were no changes considered that were not included.

4.5 Assumptions and Constraints

There is no constraint limiting the bus monitor approach to only one method. Although a single method that meets all requirements would generally be superior from many aspects, it may be too expensive for the majority of applications. A two or even three method approach may be more cost effective overall, thus more desirable.

It is assumed the paradigm for acquiring data from avionics busses has not changed with the introduction of high-speed network busses like Fibre Channel. Data systems are installed to independently gather data without influencing or affecting the bus it is monitoring. Also, the limiting factor for gathering data from an avionics system is the throughput limit of the data system – generally the recorder or the transmitter not the limitation of the interface method. For example, given 6 nodes on an avionics bus, an approach that limits gathering data from only two nodes at one time is not considered adequate.

It is recognized that through the structured approach to this project, a new paradigm may emerge. One that may discount or even disregard some of the tenets provided in this and other documents.

5 Concept for New or Modified System

5.1 Background, Objectives, and Scope

For many reasons the DoD is embracing the use of commercial technology in many of today's weapons platforms. This makes a lot of sense – especially in the area of communication standards. The large numbers of computers connected to the Internet has brought the cost of 10 MB Ethernet boards literally to a few dollars apiece. Custom made communication boards that run at the same speeds can cost more than a couple of thousand dollars. Articles in "Military & Aerospace Electronics" and "Electronic Design" have listed several weapons platforms upgrading their avionics systems with Fibre Channel. Fibre Channel is an ANSI standard operating at speeds greater than 1000 times that of 1553. With speeds at these rates, most designers are using fiber optic cables in their avionics systems.

The objective for the Fibre Channel Bus Monitor System (FCBMS) is to monitor the Fibre Channel avionics bus for data of interest during testing, format the data, and send it on to the Test and Evaluation (T&E) data system. The general system relationships remain as they were in Figure 1. The only difference is that the production avionics system is now based on Fibre Channel rather than Mil-Std-1553. However, this isn't as trivial as it might sound. The speed, architecture, and fiber optic cabling make interfacing to the bus a challenge.

Fibre Channel systems are usually designed as a switched fabric as shown in Figure 4. The data sent from one node passes through the switch. The switch looks at the address of the data and forwards the data to the correct recipient. Unlike the 1553 bus, only the recipient(s) sees the

data. The method of tapping into the Fibre Channel avionics bus has not been determined. Figure 4 therefore shows this as a cloud instead of a specific bus tap. The scope of the proposed system remains the same as the 1553 bus monitor system. It will consist of the Fibre Channel interface(s), and the central unit where the data is formatted, the program is stored, and the data system interface is located.

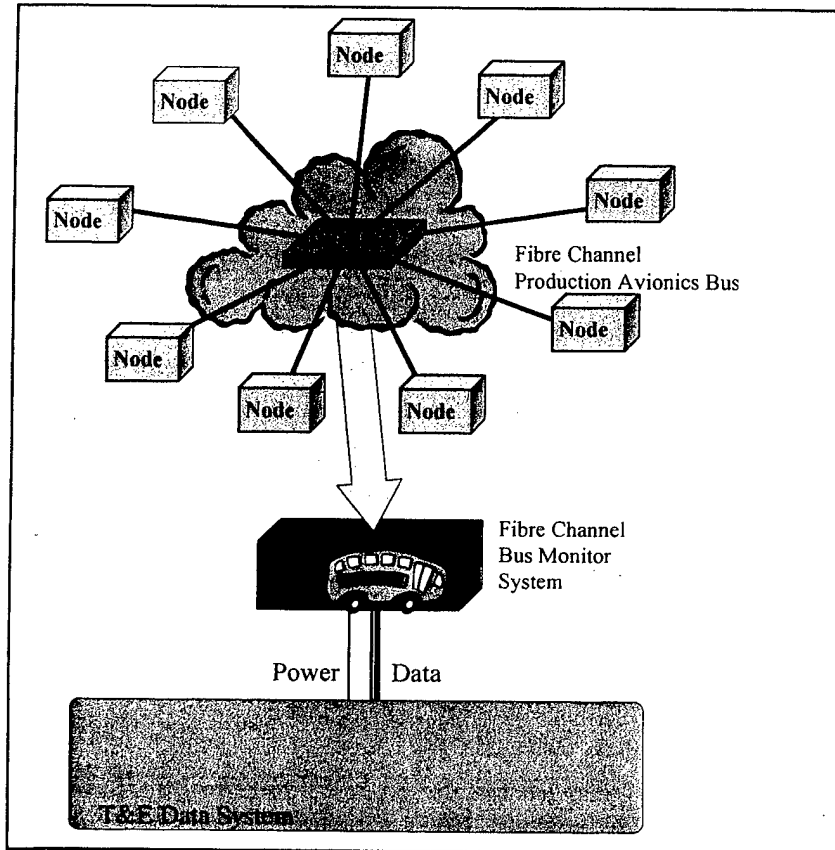

Figure 4 Fibre Channel Bus Monitor System Context

5.2 Operational Policies and Constraints

Although there are always exceptions, in general, the Fibre Channel bus monitor must adhere to the following constraints

- Must adhere to the Fibre Channel standards.
- Must not interfere with normal operation of the Fibre Channel bus.
- Must not introduce additional failure modes

5.3 Description of Current System

5.3.1 Operational Environment

The system operates in an airborne uninhabited fighter environment. This implies a rugged environment with tolerances toward higher shock, vibration, temperature extremes, humidity, etc. Its use on test vehicles requires a small volume to allow installation in space constrained environments.

5.3.2 Major System Components

Since this is a proposed system, the actual configuration is expected to vary based on any additional requirements levied above the basic monitoring requirement. The general physical configuration is expected to be similar to the existing 1553 bus monitor with two main components.

- **Fibre Channel Interface(s).** A test article is expected to have one Fibre Channel avionics bus. However, since the method of interfacing has not been determined, there may be as few as one and as many as the number of nodes in the avionics system. Depending on the test, not all nodes may need to be monitored.
- **Central Unit.** The central unit performs four main functions. The pre-programmed instructions of what data is of interest is stored during system setup. During operation, the bus data being received across the Fibre Channel interface is compared to the instruction set stored in memory. The data that is of interest is formatted into a message that is transmitted across the data system interface to the data system.
 - *Program storage* – Memory to which the user uploads operational instructions.
 - *Data comparator* – Compares incoming data messages to instructions in program storage.
 - *Data Message Formatter.* – Formats selected data into a data system message structure.
 - *Data system interface* – Physical interface into the data system.
- **Programming Software.** This software may be a standalone program or a part of the overall data system software. The software provides an interface that allows the user to select the data of interest. The software uploads the instructions into the program storage memory via the data system interface.

5.3.3 Interfaces to External Systems or Procedures

The external interfaces are not expected to change significantly from the current system in theory. However in practice, the two major external interfaces – avionics bus interface and the data system interface – will be different. The avionics bus interface will be Fibre Channel instead of 1553. State-of-the-art data systems are upgrading their architectures to handle data intensive requirements like a Fibre Channel Bus Monitor. As a result the data system will most likely be something different than is currently in use.

From a process perspective, the instrumentation engineer will need to research the data available on the bus and uniquely identify that data to the data system. This is similar to procedures in place now for current systems.

The new system will still need to be programmed before it is useful as a bus monitor. The logical architecture of the new data system has not been completely defined because commercial network standards don't dictate it. The logical architecture could be a command/response type like current systems are or a peer-to-peer type (reference section 8.1.1 for additional information). In a peer-to-peer case, the nodes of the data system are programmed to operate independently. The logical architecture of the data system will have an effect on how tightly coupled the bus monitor programming software is to the rest of the data system.

5.3.4 Capabilities/Functions of the New or Modified System

The function of the proposed system is to watch for data on the avionics bus. When data arrives, it is checked against its internal programming. Selected data is sent to the formatter while

unwanted data is discarded. The data is formatted appropriately and sent to the data system interface where it is sent to the appropriate nodes within the data system.

The increased data available on a Fibre Channel avionics bus as well as increasing data requirements in general have driven data systems to higher bandwidth data bus. Even the higher bandwidth data system bus would be swamped in a heavily loaded Fibre Channel avionics system. To avoid overloading the data system bus, the user will have to carefully select which data is of interest.

Fibre Channel is not expected to totally replace 1553 avionics busses in the near term. The Fibre Channel Bus Monitor will operate within a data system with both current 1553 and Fibre Channel avionics bus monitors as shown in Figure 5.

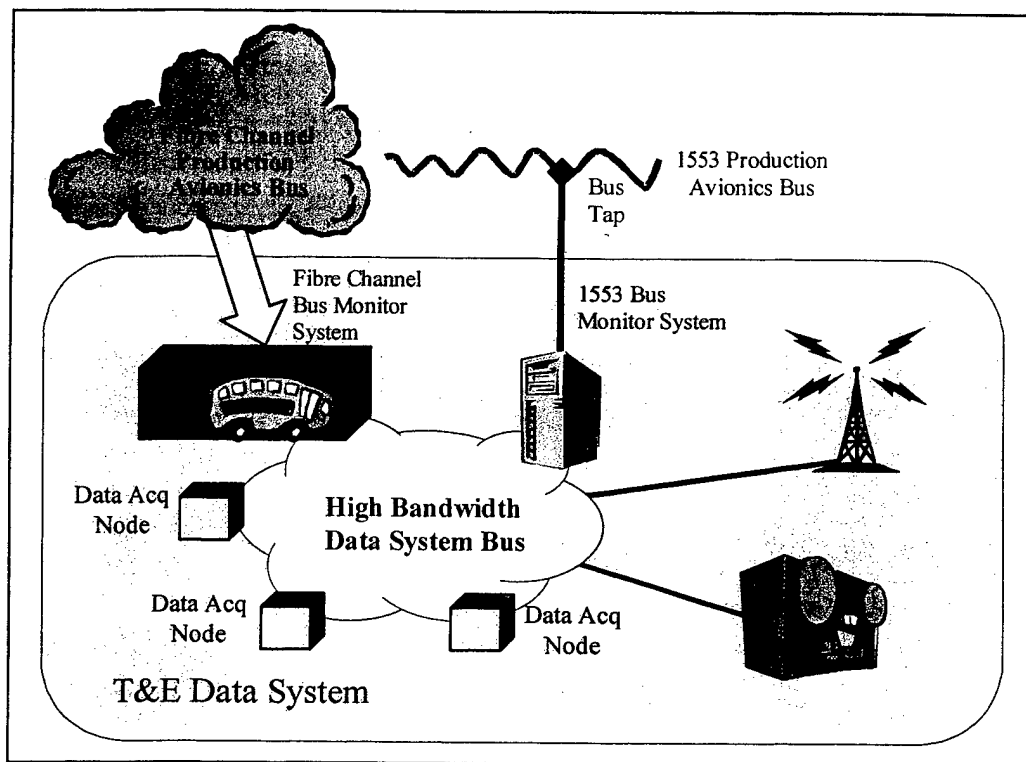

Figure 5 Future Concept of Typical Data System

5.4 Users or Involved Personnel

There are four types of users involved with operating this product. In some organizations, a single individual could accomplish more than one function.

- **Instrumentation Engineer** – This person understands the technical details of the capabilities of this system and how they relate to the requirements the data system must fulfill overall. This person is responsible for programming the system to obtain the desired performance. This person is also involved with the installation of the FCBMS insofar as where it will be located and what wiring needs to be run to support it.

- **System Installer** – This person physically installs the unit into the test article in the location the engineer has identified. This person has direct knowledge (or a support structure) of how to ensure the FCBMS is installed in a safe manner relative to the vehicle to which it is installed.
- **Cable Installer** – This person physically installs the wiring as identified by the engineer. This person has the knowledge of how to properly route and constrain the wire runs throughout a given test vehicle. This person may need a working knowledge of handling fiber optic cables, e.g. routing and splicing.
- **Test Operator** – The test operator is the person actually performing the test. Dependent upon the type of test, this could be a pilot, driver, or lab technician. This person has no detailed knowledge of the FCBMS or its capabilities. The extent of operator involvement is limited to an overall data system power switch.

5.5 Support Concept

The details of the support concept employed by each organization vary. The support concept is based largely on how they are funded, the number of systems fielded on daily, monthly or annual basis, and their relationship with the customer. What is common is the fact that FCBMS are expected to be commercial products. Any repairs or replacements are handled directly with the factory. This implies that each organization have some contract mechanism available to reach that particular vendor.

6 Operational Scenarios

6.1 Installation

Users:	Instrumentation Engineer (System Layout/Design) System Installer (Hardware mounting) Cable Installer (Electrical connections)
External System	Test vehicle (Physical) Data System (Physical)
Interfaces:	Avionics System (Physical)
Mode:	Powered Down / None

Conceptually the FCBMS will consist of several physical pieces. The central unit (CU) houses the avionics bus tap interface, the data formatter and the data system interface. Dependent upon the avionics design and the data required to monitor, there will be one or more remote bus taps (RBT). Installation consists of:

- Mounting the FCBMS in the test article.
- Connecting the FCBMS to the data system (both data and power).
- Connecting the FCBMS to the Avionics system.

During unit installation, the user will provide the FCBMS (CU plus RBTs) to the system installer. The system installer will build the appropriate brackets/hardware to hold the units firmly in the test vehicle throughout its operating environment. Since many of the test articles are space constrained, there is usually only access to one face of the FCBMS available. Special mounting hardware may be required.

The wiring from the avionics bus tap to the RBT and from the RBT to the CU will be routed through the test article by the cable installer. Appropriate connectors will be installed connecting the CU and RBT(s)⁴. The cable installer will connect the CU to the data system by routing two cables -- one for the data and one for the power.

Most likely the avionics system will use fiber optic cabling. It is not clear at this time whether the 'wiring' used in the FCBMS will be copper or fiber optic.

6.2 System Setup

Users:	Instrumentation Engineer (Functional Design)
External System	Data System (Electrical)
	Ground Support System (Logical)
Interfaces:	
Mode:	Program

The FCBMS can be programmed while on the bench or while installed in the test article. The unit must be programmed prior to use. The ground support system is electrically connected to the data system. It is therefore logically connected to the FCBM. Prior to actually programming the unit, the instrumentation engineer determines what data on the avionics bus is of interest. This determination is primarily based on the requirements of the test engineer(s). Once a data list is created, it is entered into the ground support system. Typical items to be entered into the support system include bus data, message format, and destination. After the data is entered, the support system loads the program values into a non-volatile portion of memory within the FCBM.

6.3 Data Acquisition during Avionics Bus Validation

Users:	Test Operator
External System	Data System (Electrical)
	Avionics System (Electrical)
Interfaces:	Test vehicle (Physical/Environmental)
Mode:	Acquisition

Acquisition mode is the default powered up state. The unit is designed to run autonomously once programmed. The users in this scenario typically have access to overall data system power, data recorder start/stop (if there is one), and transmitter on/off (if there is one). When operating, there is no difference in operation between 6.3 and 6.4. The difference comes in how they are installed.

When validating the bus, the data on the bus is compared against known data also called "truth data". Truth data comes from other systems or data sources (some are installed specifically for a test) with known accuracies and capabilities. When acquiring the data, the FCBMS must be transparent to the avionics system. This is accomplished during the installation design by carefully choosing interface and data gathering methods that do not affect the bus. For example, programming the avionics software to send additional data to an instrumentation port would

cause the system react differently to accommodate the data system. A subsequent avionics problem might be attributable to the increased processing or additional bandwidth used to acquire the data.

The FCBMS monitors the data, compares the data against the programmed instructions. The program tells the FCBMS to either ignore the data or package the data into a message and forward it to a destination in the data system.

6.4 Data Acquisition with Avionics Bus as Truth Data Source

Users:	Test Operator
External System:	Data System (Electrical) Avionics System (Electrical)
Interfaces:	Test vehicle (Physical/Environmental)
Mode:	Acquisition

Acquisition mode is the default powered up state. The unit is designed to run autonomously once programmed. The users in this scenario typically have access to overall data system power, data recorder start/stop (if there is one), and transmitter on/off (if there is one). When operating, there is no difference in operation between 6.3 and 6.4. The difference comes in how they are installed.

Once the bus has been validated and the test engineer is comfortable with the quality of data on the bus, other methods of interfacing to the avionics bus become acceptable. The method used when validating the bus is acceptable by definition. That method may be costly or limited in capability. As a result, there may be other methods that may become acceptable now that the bus has been validated. These methods allow the production system to know that an instrumentation data system is present and react accordingly. The actual method(s) employed will be discussed in future documents.

The FCBMS monitors the data, compares the data against the programmed instructions. The program tells the FCBMS to either ignore the data or package the data into a message and forward it to a destination in the data system.

7 Summary of Impacts

7.1 Operational Impacts

This system is in response to the need to move more data around the weapons platform. During testing, the additional data will need to be monitored to ensure the validity of the source or to identify what is happening on-board. The impact of this additional data will show up in several ways. The knowledge of ever increasing data requirements has led the T&E community to find a higher bandwidth data bus to move more data between data system components. However, just moving more data is not enough. There must be sinks for the data. Data sinks include displays, recorders, and transmitters. Higher bandwidth recorders and transmitters will impact the data reduction facility. Both will affect the amount of data that needs to be processed for the test engineer. The recorder also means more data to archive.

The Fibre Channel avionics bus interface method has yet to be determined. There is significant potential for the interface method to change the way T&E requirements are viewed by the avionics designers. One concept is to program the avionics system with the T&E data needed and send the data to a known T&E address.

7.2 Organizational Impacts

- The use of fiber optics will require the T&E organizations to become familiar with handling, routing and splicing optical cables.
- Personnel will need to be knowledgeable of Fibre Channel and appropriate network protocols.
- Test equipment to support Fibre Channel protocols and rates will be required.
- Since Fibre Channel is a commercial network standard, the vendors may be different than we are used to dealing. New contracts vehicles may be required.

7.3 Impacts During Development

The T&E organizations will need a small team of people that understand Fibre Channel, the implications of various interface methods, and how the various methods will affect T&E operations. Most importantly is whether a particular interface or method of data collection will add any significant failure modes to the test vehicle.

Both the management and the team must be open to what may currently be considered unconventional approaches to meeting the need of collecting bus data.

8 Notes

8.1 Fibre Channel Introduction

Fibre Channel is the general name of an integrated set of standards being developed by the American National Standards Institute (ANSI) which defines new protocols for flexible information transfer. Fibre Channel development began in 1988 as an extension of work on the Intelligent Peripheral Interface (IPI) Enhanced Physical standard, and branched out in several directions. Fibre Channel is a serial protocol that is unaware of the content or meaning of the information being transferred.*

8.1.1 Architecture

Fibre Channel by itself does not imply the type of architecture an instrumentation system must utilize. There are two basic architectures that can be employed in the design of the system. The nodes may or may not support both architectures. In the traditional system, a controller or master is used to command the nodes and receive the responses. The controller is programmed with the knowledge of the overall format and directs each node to acquire data and respond (reference Figure 6). The controller typically becomes the aggregator of the data as it formats the output(s) for recording, transmitting, or processing. This keeps the nodes simple. Traffic on

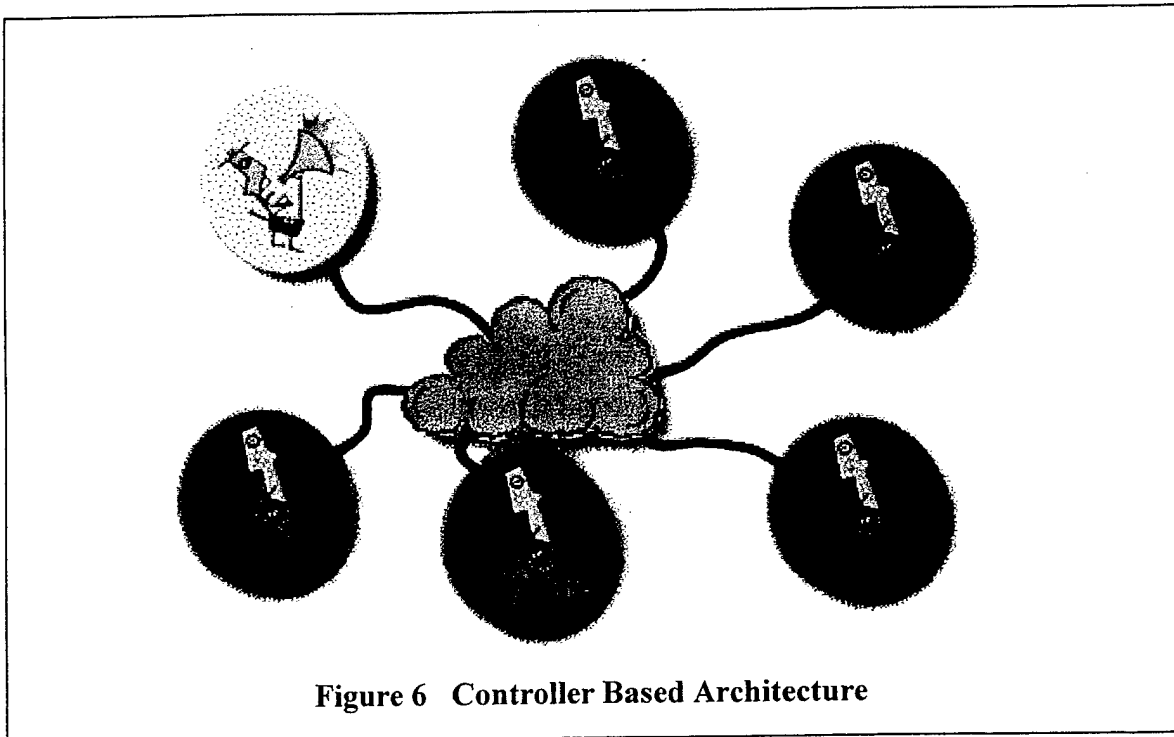
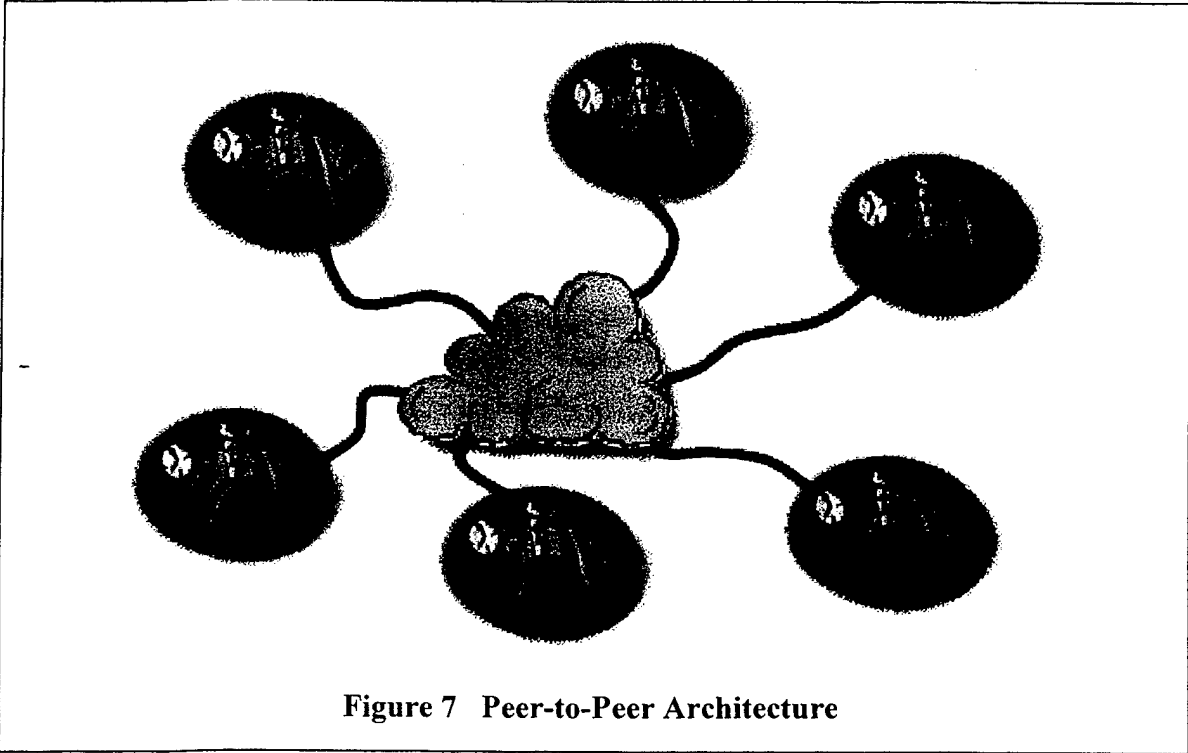

Figure 6 Controller Based Architecture

the bus is very orderly based on what the controller requests. This is known as a command-response architecture. Multiple formats can be stored in the controller and changed via an external switch or sophisticated uplink. Controllers can vary from small, inexpensive units that are inflexible to large expensive units that can do everything.

* "What is Fibre Channel?", fourth edition, Ancot Corporation

Another architecture available to the instrumentation network is the peer-to-peer architecture. Each node is programmed with its own schedule. Individually the nodes determine when to acquire the data, how to packetize the data, whom to send it to, and how often to send it (reference Figure 7). One of the advantages of an autonomous system is the ease of adding new nodes. Additional nodes just need to be physically connected to the bus and programmed. The other nodes are not affected (assuming plenty of bandwidth on the bus). One node could still receive all the data and format it into the proper outputs for recording and transmitting similar to the command response architecture.



8.1.2 Topology

Fibre Channel defines three major topologies - point-to-point, fabric, and arbitrated loop. The point-to-point topology is the simplest. It connects two ports with a bi-directional link consisting of a transmit cable and a receive cable (reference Figure 8).

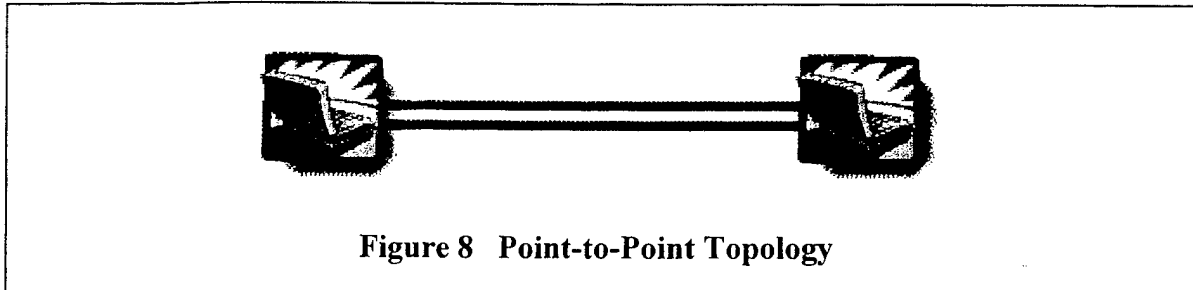

In the Fabric topology, each node is connected to a switch. Depending on the capabilities of the switch, any node may connect to any other node (reference Figure 9). When denoting Fabric topologies, the Fabric is shown as a cloud. This represents the Fabric notion without showing

any physical connections. One of the drawbacks of Fabric, is the requirement for one or more Fabric switches that physically take the place of the network cloud. These are not necessarily cheap - especially for a test environment. Because of the connectivity, adding additional nodes increases the total bandwidth available to the system. In reality, this is only true if there is a broad distribution of network traffic. If all nodes are trying to talk through one link to the recorder, then more nodes will only make it worse.

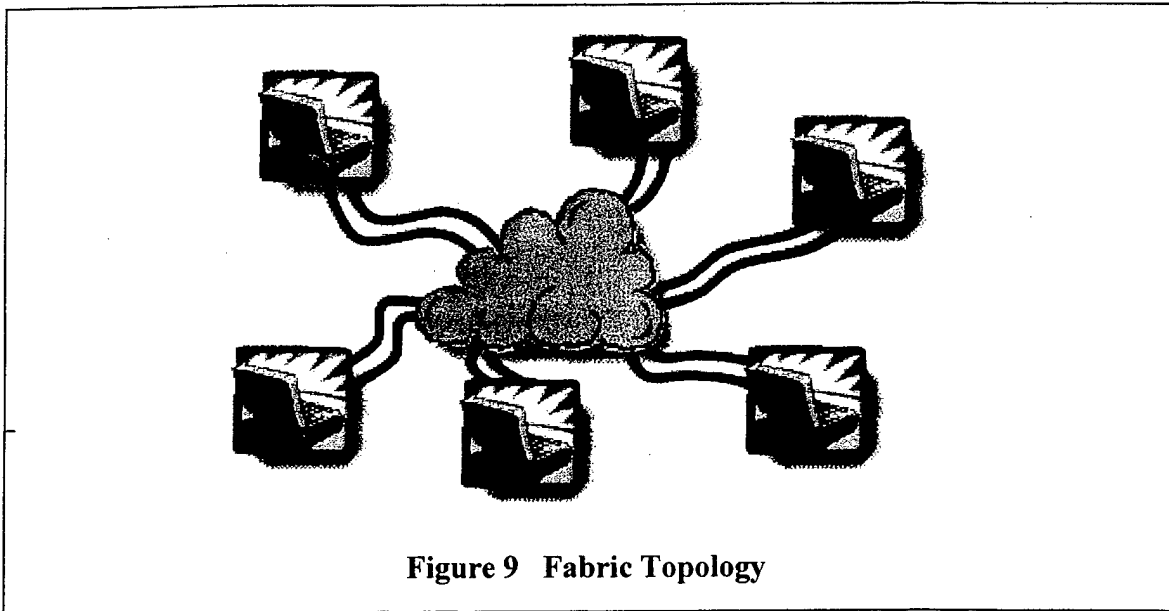

The arbitrated loop topology is a simple concatenation from the transmitter of one node to the receiver of the next. This progresses through all nodes until the last transmitter is connected to the first receiver to form a loop (reference Figure 10). Simplicity is one of the advantages of a loop. There is no additional network hardware required for connectivity. To add more nodes, the loop is broken with the additional nodes being inserted between the break. One of the drawbacks of a loop is the constant bandwidth. Regardless of the number of nodes, they all share the same bandwidth.

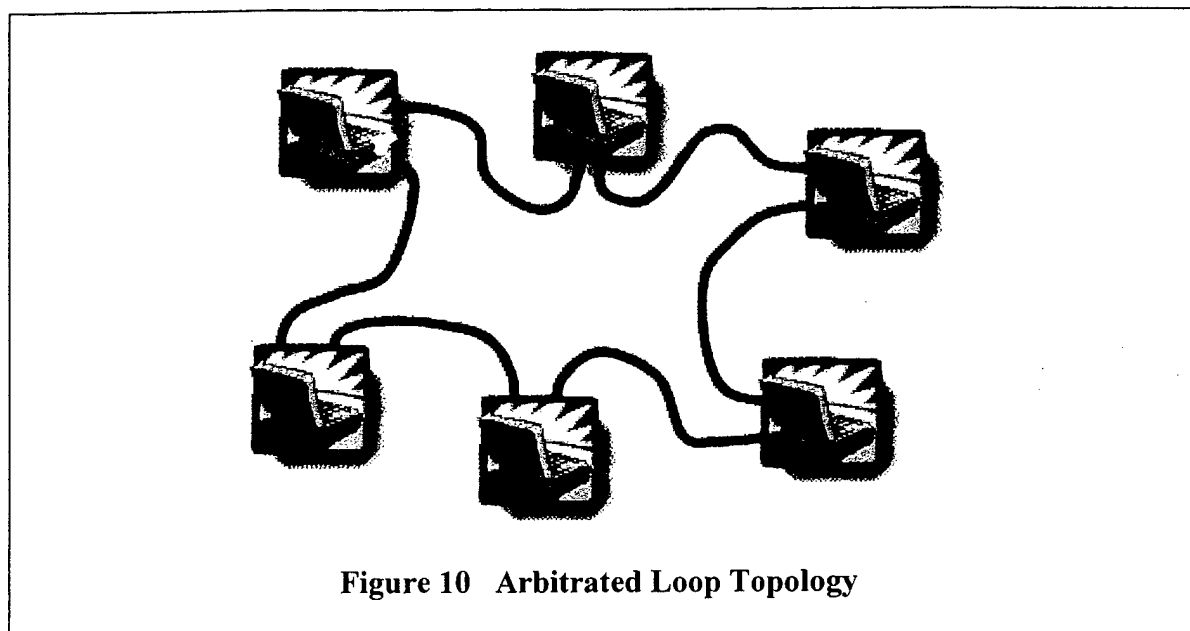

The last type of topology available is the hybrid topology. The hybrid topology simply replaces one of the fabric nodes with a loop. Conversely, it replaces a loop node with a fabric (reference Figure 11). This is one instance of a hybrid topology, of which there are many variations. This topology has the pros and cons of both reference Table 1:

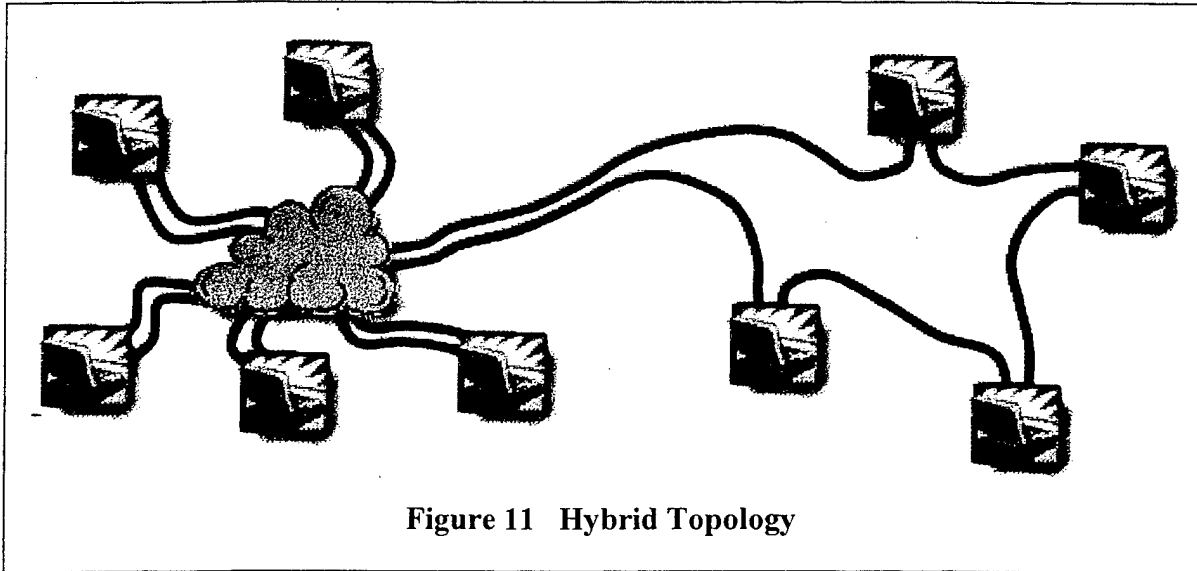

Figure 11 Hybrid Topology

Table 1, Topology Characteristics

	Fabric	Arbitrated Loop
Pro	Scaleable Bandwidth Unlimited Nodes More Fault Tolerant	Simple to Implement Cheaper (No additional components)
Con	Complex to Implement More Expensive (Requires Switch)	Constant Bandwidth 126 nodes maximum per loop 1 fault disrupts the loop

8.2 Acronyms & Abbreviations

1553	Mil-Std-1553
BC	Bus Controller
BMS	Bus Monitor System
CAIS	Common Airborne Instrumentation System
CU	Central Unit
DSC	Data System Controller
FCBMS	Fibre Channel Bus Monitor System
RBT	Remote Bus Tap
RT	Remote Terminal
T&E	Test and Evaluation

8.3 Fibre Channel Reference Material

- **“Fibre Channel: Connection to the Future”**, The Fibre Channel Association, 1995
- **“What is Fibre Channel?”**, Fourth Edition, Ancot Corporation, 1997
- **“Fibre Channel: The Basics”**, Stephens, Gary R. and Jan V. Dedek, 1997
- **“The Fibre Channel Consultant: A Comprehensive Introduction”**, Kembel, Robert W., 1998
- **“Fibre Channel: Gigabit Communications and I/O for Computer Networks”**, Benner, Alan F., 1996

Appendix E

External Interface Requirements

Fibre Channel Avionics Bus Monitor

External Interface Requirements

Johns Hopkins
System Engineering Project

Course No. 645.770

Sid Jones
December 13, 2000

Ray Schulmeyer
Advisor

1 Scope

The goal of this document is to describe the external interfaces as seen by a Fibre Channel Avionics Bus Monitor. This will be accomplished by identifying all external interfaces and describing their requirements.

2 System External Interface Requirements

2.1 Interface Identification and Diagrams

There are three external interfaces for the Fibre Channel Avionics Bus Monitor System – The Fibre Channel (FC) Avionics Bus, The Test and Evaluation (T&E) Data System Bus, and T&E Data System Power. Table 1 identifies these interfaces along with their associated project unique identifier (PUID), interfacing entities, and interface characteristics. Characteristics identified as ‘primary’ impose their requirements on other interfacing entities. Conversely, interfaces identified as ‘secondary’ have requirements imposed on them by the interfacing entity. The interfaces are shown graphically in **Figure 3** and will be discussed in the succeeding sections.

Table 1 External Interfaces

Name	PUID	Interfacing Entities	Characteristics
FC Avionics Bus I/F	XIF-FC	Production Avionics Bus	Secondary, Input
T&E Data System Bus I/F	XIF-DATA	COTS Data System Bus	Secondary, Bi-directional
T&E Data System Power I/F	XIF-PWR	Data System Power Distribution	Secondary, Input

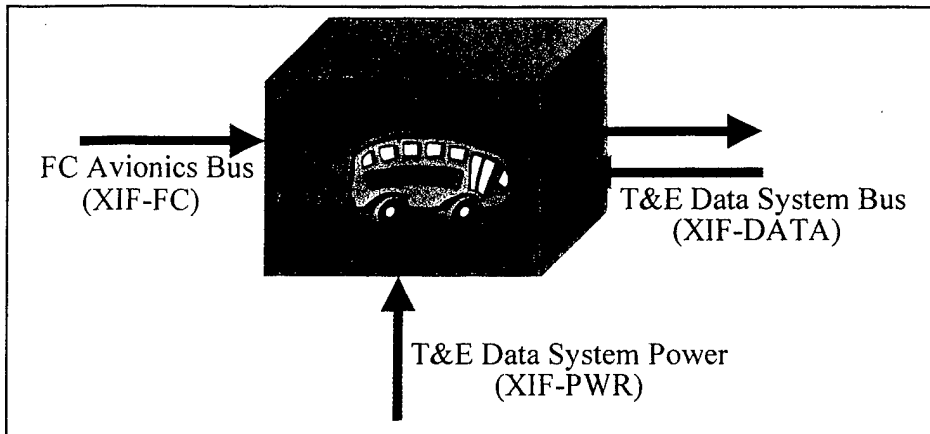

Figure 3 External System Interfaces

2.2 Fibre Channel Avionics Bus I/F (XIF-FC)

2.2.1 Purpose

This interface provides avionics data transfer from the production avionics bus to the bus monitor.

2.2.2 Description

Messages from the Fibre Channel Avionics Bus will traverse this interface. This message will be encapsulated using transport, network, and data link protocols decided upon by the avionics designer as shown in Table 2. The Fibre Channel interface will have to adhere to the same Fibre Channel standards used by the avionics system. At the top level, the standards would be the ANSI standards as listed in section 2.2.10. These standards are expected to be modified by the ANSI Fibre Channel Avionics Environment Technical Report. A manufacturer or platform specific report may further modify the Fibre Channel standard used by the avionics. The implication to this interface is that it must be programmable to accommodate these potential differences. Layered on top of the Fibre Channel are the network and transport protocols. Again, these may be different for various manufacturers and platforms. As these issues are identified, this document will be updated.

Table 2 XIF-FC Layered Model

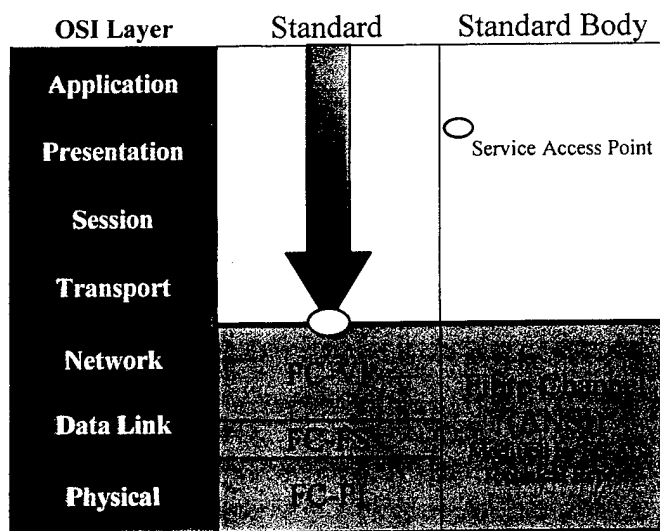

2.2.3 Priority

The system shall assign a high priority to this interface. All data of interest must be captured.

2.2.4 Type

This shall be a real-time interface.

2.2.5 Characteristics of Incoming Data Elements

Name	FC Avionics Bus Data
Source	Production FC Avionics Bus
Data Type	Payload
Size/Format	As defined in section 2.2.10

PUID	DI-FC
Units	Not Applicable
Range	Not Applicable
Accuracy	Not Applicable

2.2.6 Characteristics of Outgoing Data Elements

There shall be no outbound communication through XIF-FC.

2.2.7 Characteristics of Communications Methods

The communications methods that shall be used are defined by the reference documents in section 2.2.10

2.2.8 Characteristics of Protocols

The protocols that shall be used are defined by the reference documents in section 2.2.10

2.2.9 Relationship to System Modes

The following table shows the relationship of the Fibre Channel Avionics Interface to the modes of the system.

Table 3 XIF-FC Relationship to System Modes

Mode: OFF When the system is in the 'OFF' state, i.e. powered down, there is no activity on the interface. The interface method shall not interfere with normal avionics operation when the bus monitor is powered off.
Mode: OPERATIONAL During OPERATIONAL mode, the interface is active. Data appearing on the avionics bus is sent across the interface where the system decides to send it forward or throw it away.
Mode: PROGRAM During PROGRAM mode, the interface is not active. The interface method shall not interfere with normal avionics operation when the bus monitor is in PROGRAM mode.
Mode: DIAGNOSTIC During DIAGNOSTIC mode, the interface is not active. The interface method shall not interfere with normal avionics operation when the bus monitor is in DIAGNOSTIC mode.

2.2.10 XIF-FC Reference Documents

ANSI X3.230-1994	Information Technology - Fibre Channel Physical and Signaling Interface (FC-PH), 1994
ANSI X3.297-1997	Information Technology - Fibre Channel Physical and Signaling Interface - 2 (FC-PH-2), 1997
ANSI X3.303-1998	Information Technology - Fibre Channel Physical and Signaling Interface - 3 (FC-PH-3), 1998
ANSI X3.nnn-200x [♦]	Information Technology – Fibre Channel – Physical Interfaces (FC-PI)
ANSI X3.nnn-200x [♦]	Information Technology – Fibre Channel – Framing and Signaling (FC-FS)

[♦] FC-PI and FC-FS are currently in work and will supercede FC-PH, FC-PH-2, and FC-PH-3

ANSI X3.nnn-200x Information Technology – Fibre Channel — Virtual Interface Architecture Mapping Protocol (FC-VI)

ANSI X3.nnn-200x Fibre Channel Avionics Environment Technical Report (due 12/00)

Boeing-STL 99A0098 F/A-18 Fibre Channel Network Interface Control Document, Rev - ,25 August, 2000 (Dist D – Limited to DoD and DoD Contractors Only)

2.3 T&E Data System Bus (XIF-DATA)

2.3.1 Purpose

This interface outputs formatted avionics bus message data transfer from the bus monitor system to the T&E Data System as well as receives system programming information.

2.3.2 Description

In the near future, the T&E Data System Bus is expected to migrate to a Fibre Channel based system as defined in the ANSI Fibre Channel Standards and modified by the IRIG (Interrange Instrumentation Group) Telemetry Standards Part II. The interface will reside in the bus monitor and be perceived by the data system as another node.

Table 4 XIF-DATA Layered Model

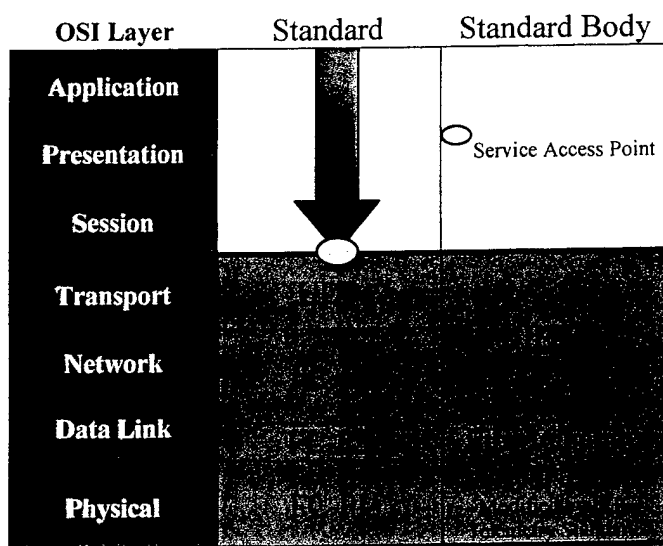

2.3.3 Priority

The system shall assign a medium priority to this interface.

2.3.4 Type

This shall be a real-time interface.

2.3.5 Characteristics of Incoming Data Elements

Name	System Programming Data	PUID	DI-SPD
Source	T&E Data System Support Unit	Units	Not Applicable
Data Type	Payload	Range	Not Applicable
Size/Format	TBD	Accuracy	Not Applicable

2.3.6 Characteristics of Outgoing Data Elements

Name	T&E Formatted Avionics Data	PUID	DO-FAD
Source	Internal	Units	Not Applicable
Data Type	Payload	Range	Not Applicable
Size/Format	As defined in section 2.3.10	Accuracy	Not Applicable

2.3.7 Characteristics of Communications Methods

The communications methods that shall be used are defined by the reference documents in section 2.3.10

2.3.8 Characteristics of Protocols

The protocols that shall be used are defined by the reference documents in section 2.3.10

2.3.9 Relationship to System Modes

The following table shows the relationship of the T&E Data System Interface to the modes of the system.

Table 5 XIF-DATA Relationship to System Modes

<p>Mode: OFF When the system is in the 'OFF' state, i.e. powered down, there is no activity on the interface.</p> <p>Mode: OPERATIONAL During OPERATIONAL mode, the interface is active. Avionics data is formatted and given a destination address within the T&E data system. The data flow across the interface is primarily from the bus to the T&E system in the form of avionics data. There may be some command activity being received by the interface from the T&E system.</p> <p>Mode: PROGRAM During PROGRAM mode, the interface is receiving data from the T&E system and stores the data in non-volatile program memory. Data being transmitted across the interface will be limited to program acknowledgement type of data.</p> <p>Mode: DIAGNOSTIC During DIAGNOSTIC mode, the interface is transmitting internal diagnostic data from throughout the bus monitor to the T&E Data System. There may be some command activity being received by the interface from the T&E system</p>

2.3.10 XIF-DATA Reference Documents

IRIG Standard 106-xx	Telemetry Standards, DRAFT of Fibre Channel implementation for data systems. Due to be released Jan, 2001
RFC-768	User Datagram Protocol (UDP), 28-Aug-80
RFC-2625	IP and ARP over Fibre Channel, June 1999
ANSI X3.230-1994	Information Technology - Fibre Channel Physical and Signaling Interface (FC-PH), 1994
ANSI X3.297-1997	Information Technology - Fibre Channel Physical and Signaling Interface - 2 (FC-PH-2), 1997

- ANSI X3.303-1998 Information Technology - Fibre Channel Physical and Signaling Interface - 3 (FC-PH-3), 1998
- ANSI X3.nnn-200x Fibre Channel Avionics Environment Technical Report (due 12/00)
- ANSI X3.nnn-200x* Information Technology – Fibre Channel – Physical Interfaces (FC-PI)
- ANSI X3.nnn-200x* Information Technology – Fibre Channel – Framing and Signaling (FC-FS)

2.4 T&E Data System Power (XIF-PWR)

2.4.1 Purpose

This interface provides the power needed to run the Fibre Channel Avionics Bus Monitor.

2.4.2 Description

The T&E Data System will provide the power required to run the Fibre Channel Avionics Bus Monitor. The T&E data system shall distribute raw aircraft power or regulated power. This allows a master switch to shut down the entire data system.

2.4.3 Priority

The system shall assign a moderate priority to this interface.

2.4.4 Type

This is a non-data interface.

2.4.5 Characteristics of Incoming Elements

Name	T&E Data System Power
Source	Production FC Avionics Bus
Data Type	Power
Size/Format	Not Applicable
Governing Standard	28Volts as defined in Mil-Std-704E

PUID	DI-PWR
Units	Volts
Range	22.0 to 29.0 steady state
Ripple	1.5 max
Transient	Transient response as defined in Mil-Std-704A (fig 9 curves 1&4 and fig 17)

2.4.6 Characteristics of Outgoing Elements

There shall be no outbound elements through XIF-PWR.

2.4.7 Characteristics of Communications Methods

Not Applicable

2.4.8 Characteristics of Protocols

Not Applicable

2.4.9 Relationship to System Modes

The following table shows the relationship of the T&E Data System Power Interface to the modes of the system.

* FC-PI and FC-FS are currently in work and will supercede FC-PH, FC-PH-2, and FC-PH-3

Table 6 XIF-PWR Relationship to System Modes

Mode: OFF	When the system is in the 'OFF' state, i.e. powered down, there is no activity on the interface.
Mode: OPERATIONAL	During OPERATIONAL mode, the interface is active. 28 VDC is supplied to the Bus Monitor.
Mode: PROGRAM	During PROGRAM mode, the interface is active. 28 VDC is supplied to the Bus Monitor.
Mode: DIAGNOSTIC	During DIAGNOSTIC mode, the interface is active. 28 VDC is supplied to the Bus Monitor.

2.4.10 Reference Documents

Mil-Std-704A Aircraft Electric Power Characteristics*
 Mil-Std-704E Aircraft Electric Power Characteristics, 1-May-91

2.5 Summary of Data Elements

Table 7 Summary of Data Elements

IF ID	IF Name	Element ID	Element Name
XIF-FC	Fibre Channel Avionics Bus Interface	DI-FC	Fibre Channel Avionics Bus Data
XIF-DATA	T&E Data Systems Bus	DI-SPD	System Programming Data
		DO-FAD	T&E Formatted Avionics Data
XIF-PWR	T&E Data System Power	DI-PWR	Bus Monitor Power
<i>XIF – External Interface</i>		<i>D – Data Element; I – Input; O – Output</i>	

* Document is no longer available. Transient characteristics are supplied in the appendix for completeness.

Appendix: Mil-Std-704A Transient Characteristics

MIL-STD-704A

*Fault Conditions (1,4)
 Bus Switching (2,3)
 Normal Equipment Switching (5,6)*

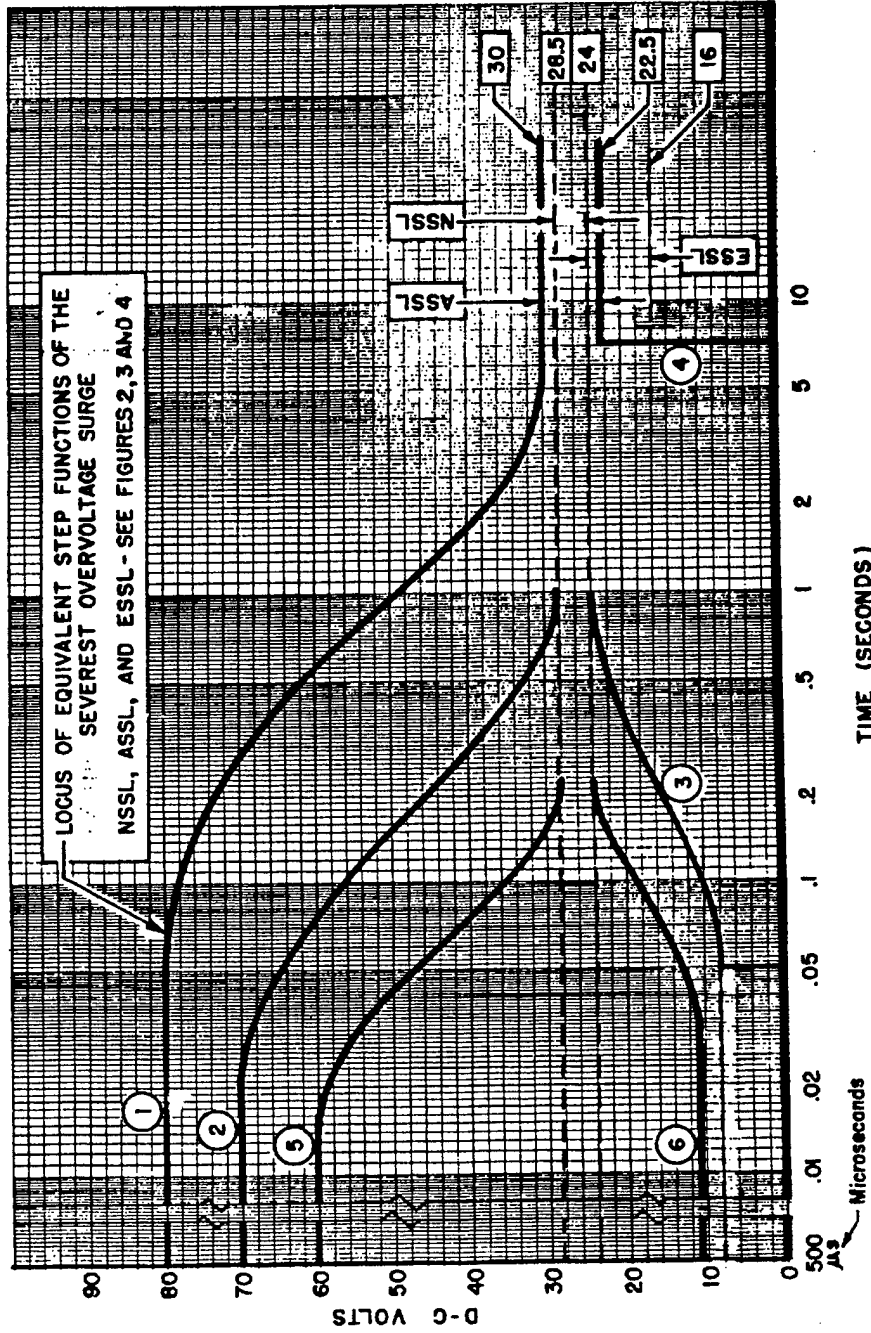

FIGURE 9. Transient surge dc voltage step function local limits for category B equipment

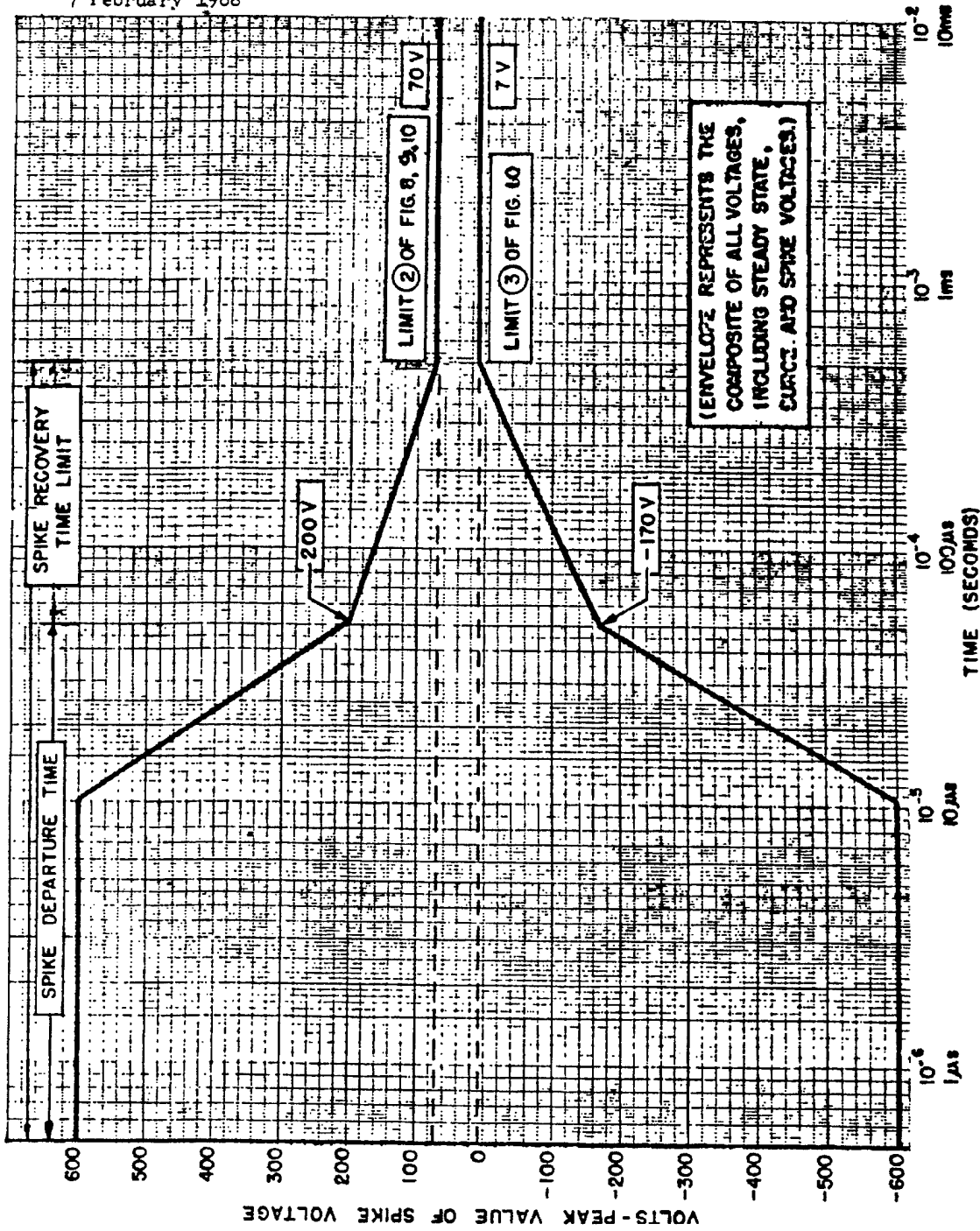

FIGURE 17. Envelope of spike voltages for dc equipment

Appendix F

System Requirements Document

Fibre Channel Avionics Bus Monitor

System Requirements

Johns Hopkins
System Engineering Project

Course No. 645.770

Sid Jones
December 13, 2000

Ray Schulmeyer
Advisor

Table of Contents

1	SCOPE	2
2	DOCUMENTS.....	2
2.1	PROJECT DOCUMENTS.....	2
2.2	REFERENCED DOCUMENTS.....	2
3	SYSTEM DESCRIPTION.....	2
4	REQUIREMENTS.....	4
4.1	REQUIRED STATES AND MODES	4
4.2	SYSTEM CAPABILITY REQUIREMENTS.....	4
4.3	REQUIREMENTS CORRELATION	7
5	NOTES	8
5.1	ACRONYMS AND ABBREVIATIONS.....	8

1 Scope

This System Requirements Document identifies the top-level operational and performance requirements for the Fibre Channel Avionics Bus Monitor. The documents listed in section two are considered part of this document by reference.

2 Documents

2.1 Project Documents

Statement of Need, 30-Oct-00

Operational Concept Document, 30-Oct-00

External Interface Requirements, 26-Nov-00

2.2 Referenced Documents

IRIG 106, Range Commanders Council Telemetry Standards, 2000

Mil-Std-704A, Aircraft Electric Power Characteristics, 09-AUG-1966

Mil-Std-704E, Aircraft Electric Power Characteristics, 01-MAY-1991

Mil-Std-461E, Requirements For The Control Of Electromagnetic Interference Characteristics
- Of Subsystems And Equipment, 20-AUG-1999

Mil-Std-810F, Environmental Engineering Considerations And Laboratory Tests, 01-NOV-2000

3 System Description

The Fibre Channel Avionics Bus Monitor is used to monitor Fibre Channel avionics busses located on weapons platforms for test and evaluation (T&E) purposes – primarily during developmental testing.

A T&E Data System acquires data during a test or mission. This data is recorded for post-flight analysis. The data may also be transmitted to a ground processing facility for in-flight data monitoring. As such, the T&E data system must be invisible to the operation and control of the aircraft. The T&E data system typically consists of independent wiring, data acquisition units, and oftentimes transducers. Upon completion of T&E, the system is removed and the aircraft is returned to fleet status. The data system may also be known as an instrumentation system or a telemetry system.

As can be seen by the red dashed box in Figure 1, a bridging system is needed to gather the data of interest from the production avionics system and format the data into something useful for the T&E data system. The bus monitor conceptually consists of two parts. The first part is the actual interface to the production avionics system identified as a bus tap. The second part is the unit that receives, formats, and outputs the data.

A block diagram of the Fibre Channel Bus Monitor unit is shown in Figure 2. The Fibre Channel interface receives avionics data from the bus tap in the Fibre Channel Avionics Network. The avionics message is time tagged via a time circuit that was synchronized from the T&E Data System. The comparator looks at the program memory for avionics messages of interest. If the message in the buffer was requested, it passes the message to the Output Message Formatter. The Formatter creates an output message based on whether the operational mode is 'Truth' or 'Validate'. Once complete, the output message is sent to the Data Interface where it enters the T&E Data Network. When in the program state, T&E support unit talks to the

Program Control through the Data Interface. The Program Control can read, load, verify, and clear the non-volatile program memory. The Diagnostic Control receives status data from all subsystems. When in the operational state, a subset of the status words are available as status messages to the data system. When in the diagnostic state, a more thorough test is done which would interrupt the data collection during normal operations. The power for the unit is received from the T&E Data System.

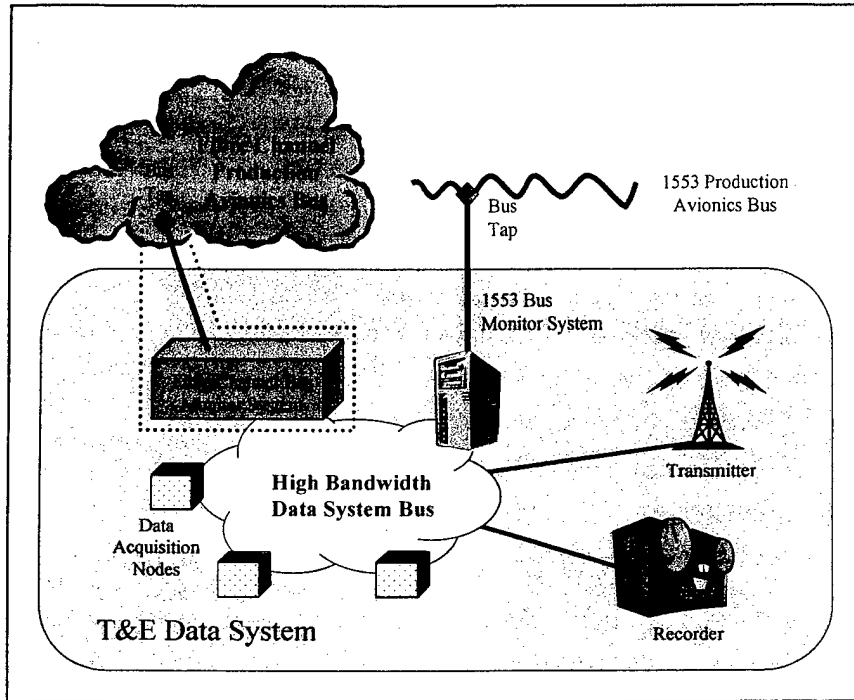

Figure 1 System Relationships

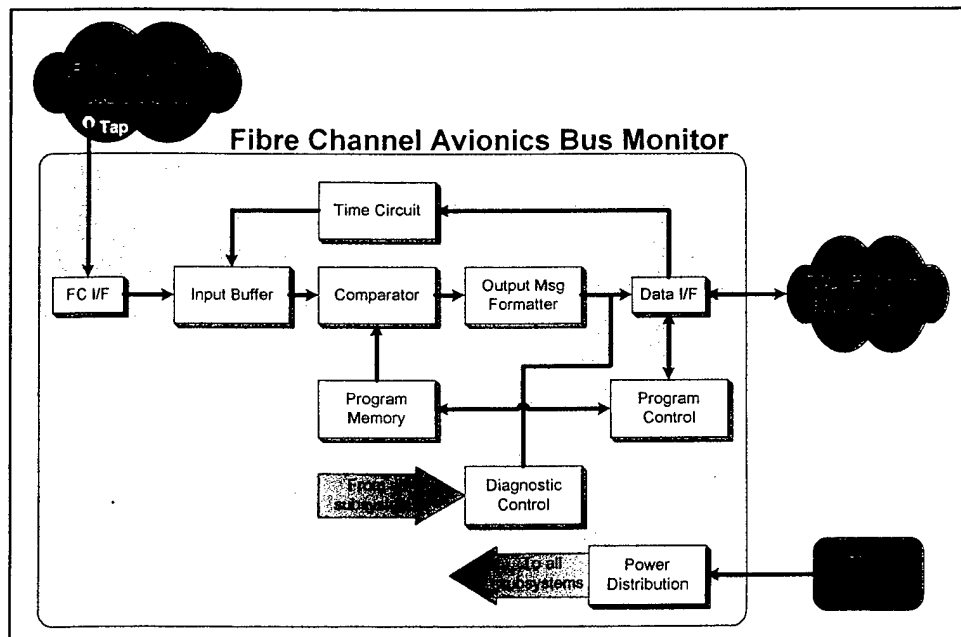

Figure 2 Block Diagram

4 Requirements

4.1 Required States and Modes

The unit shall have the following states as a minimum. Additional states or modes are allowed.

4.1.1 OFF

This state is characterized as having no power applied to the power input interface. There is no difference made to whether the unit is sitting on a storage shelf or wired in an operational configuration.

4.1.2 OPERATIONAL

This is the normal state of the unit. During this state, data from the Avionics Bus Monitor Interface (XIF-FC) is formatted based on internal program requirements for dissemination across the T&E Bus Interface (XIF-DATA).

4.1.2.1 *Validate Mode*

This mode is used when the quality of the production avionics data is suspect. Generally when using this mode, one or more of the avionics sub-systems are under test. The actual data values being sent are only half the story. Other equally important questions include: the state of the bus, which node sent the data and when, and which nodes received the data and when.

4.1.2.2 *Truth Mode*

This mode is used when the production avionics data is known to be good. The avionics data was previously validated and is now considered the truth source in validating other systems. During this mode, only the data is of concern – not the state of the bus.

4.1.3 PROGRAM

When in the program state, the unit is receiving instructions across the T&E Bus Interface (XIF-DATA) and storing them in non-volatile memory for execution during the Operational state.

4.1.4 DIAGNOSTIC

The diagnostic state allows the user access to all areas of memory through the XIF-DATA interface.

4.2 System Capability Requirements

4.2.1 Fibre Channel Avionics Bus

4.2.1.1 *Interference with normal avionics operation*

Regardless of the state of the unit, operation of the avionics bus shall not be compromised.

4.2.1.2 *Avionics Compatibility*

The Fibre Channel standard does not guarantee interoperability. Given the absence of a Fibre Channel Avionics standard, it is envisioned that manufacturers of different platforms may design their Fibre Channel avionics network differently. This unit shall be configurable to accommodate multiple Fibre Channel avionics approaches. Configurability may include, but is not limited to, a modular approach where the interface board is swapped out.

4.2.1.3 *Number of Avionics Interfaces*

The amount of data that can be monitored is limited by the output bandwidth of the unit. A single Fibre Channel interface may consume the entire output bandwidth available. However, due to the point-to-point nature of Fibre Channel communications, data may be required from multiple nodes. In a system with two mission computers connected to redundant switches, the

minimum requirement will be to monitor both receive lines from both switches to each mission computer or four interfaces. The unit shall accommodate -1 to n avionics input interfaces, where $n \geq 4$.

4.2.1.4 Number of Bus Messages

Fibre Channel avionics systems are only now being developed. In the absence of hard numbers for the quantity of bus messages available, the number of Mil-Std-1553 messages (2^{16}) will be used as a starting point. The unit shall be programmable to select up to 65536 individual messages.

4.2.2 T&E Data System

4.2.2.1 T&E Data System Compatibility

The current DoD data system standard is the Common Airborne Instrumentation System (CAIS). To meet future requirements, the Range Commanders Council (RCC) has identified Fibre Channel as the basis for the next generation data system. The T&E data system interface shall be CAIS or Fibre Channel as defined in IRIG 106.

Note: Good design and marketing practices would allow for a modular interface that could be swapped out for either interface desired.

4.2.2.2 Validate Mode Data Format

Validate mode is used when the bus data is being tested and therefore not a source of truth data. When in Validate mode, other information besides the data shall be captured. It is expected that all messages will be transferred within a single Fibre Channel frame. The entire Fibre Channel frame shall be time tagged and encapsulated as the data payload (less the start and end of frame identifiers) An example is shown in Figure 3 (A).

4.2.2.3 Truth Mode Data Format

Truth mode is used when the bus data is being used as a truth source. The data is believed to be accurate. When in Truth mode, only the time tag and message data shall be sent across the T&E interface. An example is shown in Figure 3 (B)

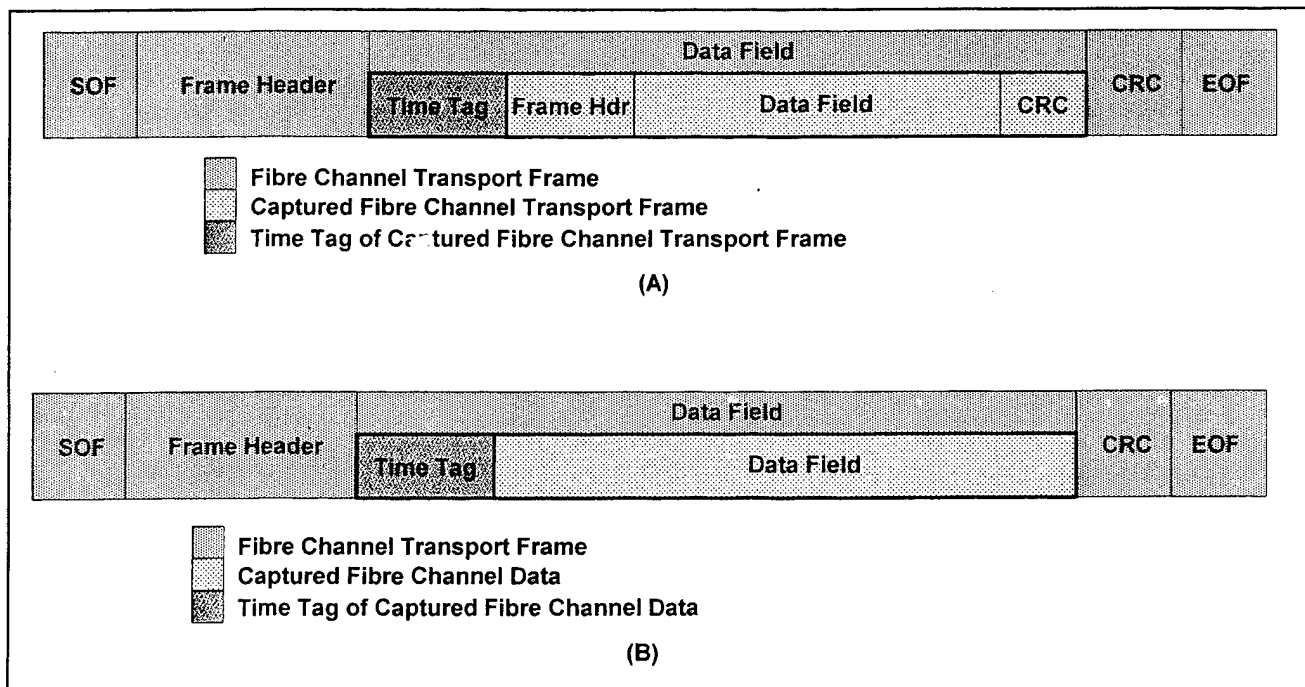

Figure 3 Example Capture Data Format, (A) Validate Mode (B) Truth Mode

4.2.2.4 Time Tagging

Time correlation of acquired avionics bus data is accomplished by internal time counters and time tagging circuits, which are synchronized to the network time broadcast across the T&E data system. Accuracy of the time tag shall be 1.0 microseconds or better. The resolution of the time tag shall be 0.10 microseconds or better. The time format shall be in accordance with IRIG 106.

4.2.2.5 Power

The unit shall operate from Mil-Std-704E 28VDC power with transient characteristics in accordance with figure 9 (curves 1&4) and figure 17 from Mil-Std-704A.

4.2.3 Logistics

4.2.3.1 Programming ports

Programmability of the unit shall be done through the T&E Data System Bus (XIF-DATA) Interface. Additional program ports such as RS-232 and Ethernet are allowed but shall not limit XIF-DATA programming.

4.2.3.2 Size

Due to small spaces available in tactical aircraft for instrumentation, the bus monitor shall be no larger than 256 in³ exclusive of mounting tabs and mating connectors.

4.2.3.3 Weight

Given the size requirements in 4.2.3.2, weight is not an issue.

4.2.3.4 Mounting

Due to small spaces available in tactical aircraft for instrumentation, the bus monitor shall have all connectors located on one face.

4.2.3.5 Connectors

The connectors used by the bus monitor shall be EMI shielded and have a positive lock mechanism.

4.2.3.6 Color

The color of the bus monitor shall be orange to identify it as test equipment.

4.2.3.7 Reliability

Reliability shall be measured in Mean Time Between Failures (MTBF). The bus monitor shall have an MTBF greater than 1000 hours.

4.2.4 Airborne uninhabited environment

Unless otherwise specified, the bus monitor shall conform to the requirements when subjected to the environmental conditions listed below.

4.2.4.1 Storage Temperature

-55°C to +100°C

4.2.4.2 Operating Temperature

The thermal design shall take into consideration ambient air using convection and radiation only. Forced air and heat sinking shall not be required.

-55°C to +85°C

4.2.4.3 Pressure Altitude

-1000 feet to +85,000 feet

4.2.4.4 Temperature/Altitude

Combined conditions of +85°C and 85,000 feet

4.2.4.5 Relative Humidity

99 percent, condensing

4.2.4.6 Vibration

- 5 to 14 Hz at 0.20 inch double amplitude
- 14 to 20 Hz at 0.10 inch double amplitude
- 20 to 33 Hz at 2g acceleration
- 33 to 74 Hz at 0.036 inch double amplitude
- 74 to 2000 Hz at 10g acceleration

4.2.4.7 Shock

Crash Worthiness	Operational
Peak Acceleration: 40g, each axis Method 516.4, procedure 5.	Peak acceleration: 20g Duration: 6 to 9 milliseconds Axis: all axes Method 516.4, procedure 1.

4.2.4.8 Electromagnetic Compatibility Limits

Conducted Emission (CE03), Radiated Emissions (RE02) and Radiated Susceptibility (RS03) per MIL-STD-461C.

4.2.4.9 Sand and Dust

The equipment shall withstand, in both operating and non-operating condition, exposure to sand and dust particles as outlined in MIL-STD-810E.

4.2.4.10 Fungus

The equipment shall withstand, in both operating and non-operating condition, exposure to fungus growth as encountered in tropical climates. In no case shall overall spraying of the equipment be necessary. If it can be shown non-nutrient materials are used, fungus test may be accomplished by analysis.

4.2.4.11 Salt Atmosphere

The equipment shall withstand, in both operating and non-operating condition, exposure to salt-sea atmosphere.

4.2.4.12 Explosive Conditions

The equipment shall not cause ignition of an ambient-explosive-gaseous mixture with air when operating in such an atmosphere.

4.3 Requirements Correlation

Table 1 correlates the requirements listed in section 4.2 with the states and modes listed in section 4.1. The requirements apply to the states and modes as indicated.

Table 1 Requirements Correlation

Requirement	States and Modes				
	Off	Operational		Program	Diagnostic
		Validate	Truth		
Fibre Channel Avionics Bus					
Interference with avionics operation	✓	✓	✓	✓	✓
Avionics Compatibility		✓	✓		
Number of Avionics Interfaces		✓	✓		
Number of Bus Messages		✓	✓		
T&E Data System					
T&E Data System Compatibility		✓	✓	✓	✓
Validate Mode Data Format		✓	✓		
Truth Mode Data Format		✓	✓		
Time Tagging		✓	✓		
Power		✓	✓	✓	✓
Logistics					
Programming ports				✓	
Size	✓	✓	✓	✓	✓
Mounting	✓	✓	✓	✓	✓
Connectors	✓	✓	✓	✓	✓
Color	✓	✓	✓	✓	✓
Reliability		✓	✓	✓	✓
Airborne uninhabited environment					
Storage Temperature	✓				
Operating Temperature		✓	✓	✓	✓
Pressure Altitude		✓	✓	✓	✓
Temperature/Altitude		✓	✓	✓	✓
Relative Humidity		✓	✓	✓	✓
Vibration	✓	✓	✓	✓	✓
Shock	✓	✓	✓	✓	✓
Electromagnetic Compatibility Limits		✓	✓	✓	✓
Sand and Dust	✓	✓	✓	✓	✓
Fungus	✓	✓	✓	✓	✓
Salt Atmosphere	✓	✓	✓	✓	✓
Explosive Conditions		✓	✓	✓	✓

5 Notes

5.1 Acronyms and Abbreviations

EMI	Electromagnetic interference
T&E	Test & Evaluation
XIF-DATA	Project unique identifier – T&E data system external interface
XIF-FC	Project unique identifier – Fibre Channel avionics system external interface

Appendix G

Trade Study – Bus Tap Method

Fibre Channel Avionics Bus Monitor

Bus Tap Method Trade Study

Johns Hopkins
System Engineering Project

Course No. 645.770

Sid Jones
January 7, 2001

Ray Schulmeyer
Advisor

Table of Contents

1	SCOPE	2
2	OVERVIEW	2
3	REQUIREMENTS	3
4	ALTERNATIVES	3
4.1	DEVELOPER'S APPROACH	3
4.2	INDIVIDUAL OPTICAL BUS TAPS AT EACH NODE	3
4.3	REPLACE PRODUCTION SWITCH WITH INSTRUMENTATION SWITCH	4
4.4	AVIONICS SWITCH WITH BUILT-IN INSTRUMENTATION SUPPORT	4
5	CRITERIA	4
5.1	AFFECTS PRODUCTION SYSTEM	5
5.2	INSTALLATION TIMELINESS	5
5.3	INDEPENDENT FROM PRODUCTION SYSTEM	5
5.4	EASE OF SUBSEQUENT FLIGHT CLEARANCE SIGN OFF	5
5.5	AVAILABILITY OF REQUIRED DATA	5
5.6	EASE OF PHYSICAL INSTALLATION	5
6	COMPARISON	5
7	CONCLUSION	6

1 Scope

This trade study identifies the various options available to the instrumentation engineer when interfacing a Fibre Channel Bus Monitor to the production Fibre Channel Avionics System.

2 Overview

The Fibre Channel Avionics Bus Monitor is used to monitor Fibre Channel avionics busses located on weapons platforms for test and evaluation (T&E) purposes – primarily during developmental testing.

A T&E Data System acquires data during a test or mission. This data is recorded for post-flight analysis. The data may also be transmitted to a ground processing facility for in-flight data monitoring. As such, the T&E data system must be invisible to the operation and control of the aircraft. The T&E data system typically consists of independent wiring, data acquisition units, and oftentimes transducers. Upon completion of T&E, the system is removed and the aircraft is returned to fleet status. The data system may also be known as an instrumentation system or a telemetry system.

As can be seen by the red dashed box in Figure 1, a bridging system is needed to gather the data of interest from the production avionics system and format the data into something useful for the T&E data system. The bus monitor conceptually consists of two parts. The first part is the actual interface to the production avionics system identified as a bus tap. The second part is the unit that receives, formats, and outputs the data.

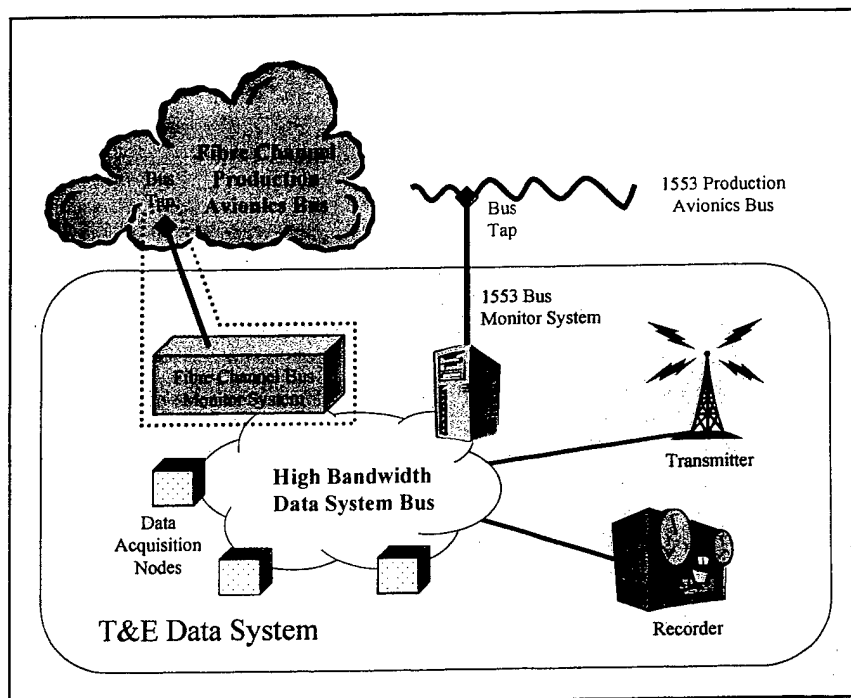

Figure 1 System Relationships

3 Requirements

The Instrumentation Group is responsible for instrumenting any type of test platform in the Navy's inventory. Some of the advanced tactical aircraft are installing networked based fiber optic busses as part of the avionics suite. Part of the flight test requirement is to collect data from these new busses. Since these networked based fiber optic busses haven't shown up in fleet assets yet, a method to tap into these busses for flight test has yet to be identified. Research indicates that initial installations of Fibre Channel Avionics Systems will utilize fiber optic cable. Since this is a more stringent requirement than purely electrical systems, monitoring busses with fiber optic cables will be the requirement.

4 Alternatives

There are four approaches that should be considered for tapping into a networked-based fiber optic bus for flight test use.

4.1 Developer's Approach

During development of the avionics system, the developer must monitor many of the same types of data of interest during flight test.

Pro

- Guaranteed to acquire bus data

Con

- Don't know what the approach is for each platform / manufacturer
- Developer may have different data requirements
- May require different approaches for each aircraft
- May not be independent of avionics hardware/software

4.2 Individual optical bus taps at each node

The logical configuration of a switched network is a star, with the switch at the center. To collect bus data, an optical bus tap would be located at *each* node of interest either at the switch or the node as shown in **Figure 2**.

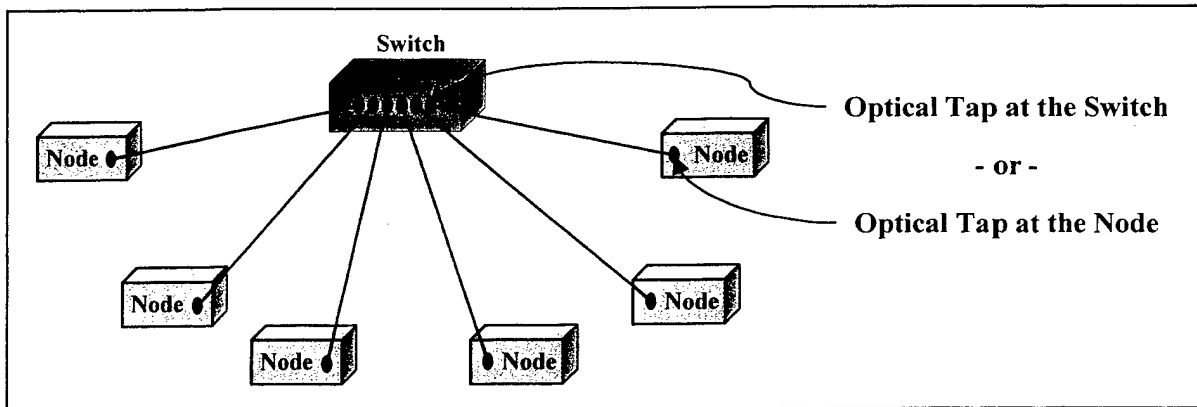

Figure 2 Individual Taps

Pro

- Scalable - add additional taps as needed
- Independent of platform
- Independent of avionics hardware/software
- Acquires all required data

Con

- Optical splices are difficult to make under the best conditions
- Optical technology is still evolving, commercial products may be available but military capable products may still have far to go
- May require active taps which is an aircraft failure mode if instrumentation fails
- Clumsy and cumbersome to mount many taps in one area

4.3 Replace production switch with instrumentation switch

The logical configuration of a switched network is a star, with the switch at the center. Replace the production switch with one that has one or more instrumentation ports. The switch can be programmed by the instrumentation group to grab the data of interest.

Pro

- Acquires all required data
- Independent of platform (provided avionics utilizing switched fabric architecture)
- Independent of avionics hardware/software

Con

- Impacts operational characteristics of avionics system
 - Flight clearance may be impossible to obtain
- Aircraft would need to be re-certified upon each installation (costly and time consuming)

4.4 Avionics switch with built-in instrumentation support

During avionics design, petition the program office to install a switch for production that has instrumentation capabilities built in. The switch can be programmed by the instrumentation group to grab the data of interest.

Pro

- Guaranteed to acquire some to all required data
- Very easy to monitor l us
- No installation or flight clearance issues

Con

- As avionics matures, instrumentation ports may be used for production
- Limited number of ports may limit data availability
- Non-independent of avionics hardware/software
- May get some platforms to buy into concept, still need approach for others

5 Criteria

The criteria with which to select the bus tap method are listed in below. The scoring method and weightings are shown in Table 1.

5.1 Affects production system

The goal of instrumentation is to monitor what is going on without affecting it. Although there are some instances when affecting the system under test is not critical; they are few and far between and almost never apply to production avionics systems.

5.2 Installation Timeliness

The capability to install or update a bus monitor system in a timely fashion is paramount. When test assets are not flying, they are not making money (i.e. distributing the flight costs across more flight hours). There are plenty of items that drive the down time of the aircraft. Stocking up on common long lead items is one way to manage the down time. Another way is to avoid time consuming installation processes.

5.3 Independent from production system

Another goal of instrumentation is to remain independent from the system/sub-system under test. When the system/sub-system is the avionics, independence is important. However, when testing other systems, avionics data is often used as truth data and therefore not as critical.

5.4 Ease of subsequent flight clearance sign off

The first time a Fibre Channel avionics bus monitor is used, a significant flight clearance/safety of flight review will result. What is important is the review process for subsequent installations.

5.5 Availability of required data

Some approaches may limit the data acquisition to a select number of nodes due to limitations in the acquisition method. Additional data would be impossible or require another data system.

5.6 Ease of physical installation

With most instrumentation, the time required to install a data system is scrutinized. The customer wants their test assets flying as much as possible. The number of components and the space they require translate directly to installation time and costs.

Table 1 Criterion Scoring and Weighting

Criterion	Units	Score	Weighting
Affects production system	Y/N	0/3	30%
Timeliness (Install when a/c shows up in hanger)	L/M/H	1/2/3	20%
Independent from production system	L/M/H	1/2/3	15%
Ease of subsequent flight clearance sign off (not first time)	L/M/H	1/2/3	15%
Availability of required data (are there data limitations)	L/M/H	1/2/3	10%
Ease of physical installation	L/M/H	1/2/3	10%

6 Comparison

The alternatives were evaluated using the units listed in Table 1 and are summarized in Table 2. Each alternative was scored using '0' or '3' for yes/no answers and '1', '2', or '3' for low/medium/high answers. Table 3 shows the raw score and weighted score for each alternative.

Table 2 Evaluation of Alternatives

Criterion	Units	Developer	Individual Taps	Instr Switch	Prod Switch
Affects production system	Y/N	N-3	N-3	N-3	Y-0
Timeliness	L/M/H	M-2	H-3	H-3	L-1
Independent from production system	L/M/H	H-3	H-3	M-2	L-1
Ease of subsequent flight clearance sign off	L/M/H	L-1	H-3	L-1	H-3
Availability of required data	L/M/H	L-1	H-3	M-2	M-2
Ease of physical installation	L/M/H	L-1	L-1	M-2	H-3
Raw Score		11	16	13	10

Table 3 Scoring of Alternatives

Alternative	Raw Score (18 max)	Wt Score (3 max)
Developer's Approach	11	2.1
Individual fiber optic bus taps at each node	16	2.8
Replace production switch with instrumentation switch	13	2.4
Avionics switch with built-in instrumentation support	10	1.3

7 Conclusion

The 'individual fiber optic bus taps' alternative was the winner, which makes sense when considering this is the current paradigm for acquiring Mil-Std-1553 bus data. The important point about this trade study was its emphasis on being able to instrument a Fibre Channel avionics system when it shows up in the hanger. Some quick projects need to be out the door in a matter of weeks. The 'individual taps' will ensure these requirements can be met. However, it may not be the most cost effective. As the technology matures and aircraft are delivered, it may turn out the other alternatives (by themselves or in conjunction with each other) may be a very effective 80% or better solution.

A sensitivity analysis was performed on the results to ensure the choice of either the utility curve or the weighting for a particular element did not affect the outcome between two or more closely matched alternatives. For this study, the top score was more than 10% of full scale above the closest challenger, which was a good overall indicator of insensitivity. To further check for sensitivity, each criterion was successively zeroed out. With the elimination of each successive criterion the order of the alternatives changed, but the winner remained constant. This shows one criterion did not drive the results. Table 4 shows the results of zeroing the criteria. For each criterion zeroed, read across the table for the results.

Table 4 Sensitivity Results

Results	Developer	Individual Taps	Instr Switch	Prod Switch
Criterion Zeroed				
Affects production system	1.6	2.6	2.0	2.0
Timeliness	1.8	2.6	2.0	1.8
Independent from production system	1.6	2.6	2.2	1.8
Ease of subsequent flight clearance sign off	2.0	2.6	2.4	1.4
Availability of required data	2.0	2.6	2.2	1.6
Ease of physical installation	2.0	3.0	2.2	1.4

Appendix H

Trade Study – Development Technology

Fibre Channel Avionics Bus Monitor

Development Technology Trade Study

Johns Hopkins
System Engineering Project

Course No. 645.770

Sid Jones
January 7, 2001

Ray Schulmeyer
Advisor

Table of Contents

1	SCOPE	2
2	OVERVIEW	2
3	REQUIREMENTS	3
4	ALTERNATIVES	3
4.1	PC/104 & PC/104+	3
4.2	PCI MEZZANINE CARD (PMC)	4
4.3	INDUSTRY PACK (IP)	4
4.4	CUSTOM DESIGN	5
5	CRITERIA	5
5.1	BACKPLANE BUS SPEED	5
5.2	TECHNOLOGY AVAILABILITY	5
5.3	ENVIRONMENT / RUGGEDABILITY	5
5.4	SUPPORTABILITY / USER BASE	6
5.5	SIZE	6
6	COMPARISON	7
7	CONCLUSION	7
8	REFERENCES	8

1 Scope

This trade study identifies several technologies that could be used to develop a flight qualified Fibre Channel Bus Monitor.

2 Overview

The Fibre Channel Avionics Bus Monitor is used to monitor Fibre Channel avionics busses located on weapons platforms for test and evaluation (T&E) purposes – primarily during developmental testing.

A T&E Data System acquires data during a test or mission. This data is recorded for post-flight analysis. The data may also be transmitted to a ground processing facility for in-flight data monitoring. As such, the T&E data system must be invisible to the operation and control of the aircraft. The T&E data system typically consists of independent wiring, data acquisition units, and oftentimes transducers. Upon completion of T&E, the system is removed and the aircraft is returned to fleet status. The data system may also be known as an instrumentation system or a telemetry system.

As can be seen by the red dashed box in Figure 1, a bridging system is needed to gather the data of interest from the production avionics system and format the data into something useful for the T&E data system. The bus monitor conceptually consists of two parts. The first part is the actual interface to the production avionics system identified as a bus tap. The second part is the unit that receives, formats, and outputs the data.

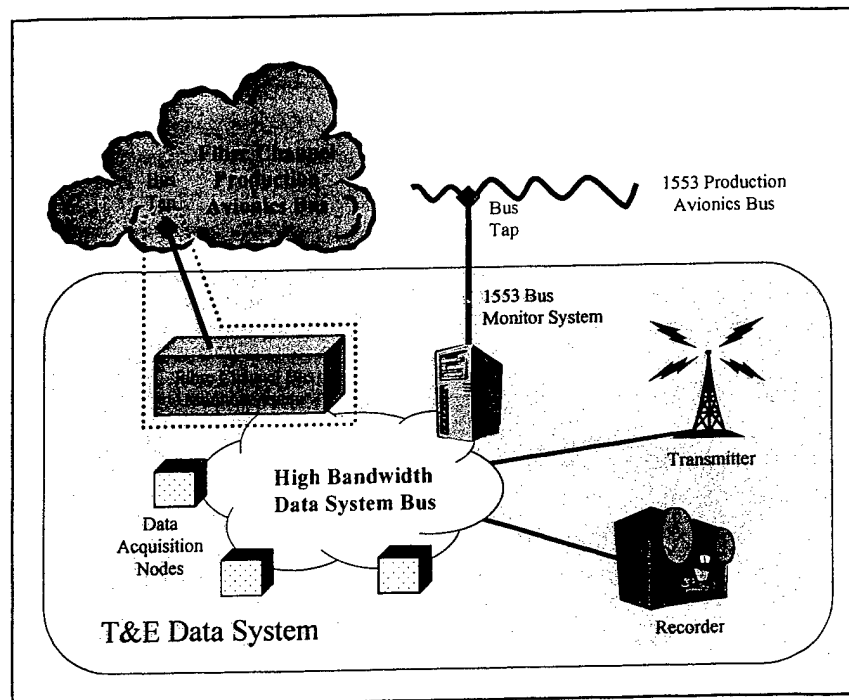

Figure 1 System Relationships

3 Requirements

A Fibre Channel Bus Monitor must be both functional and cost effective. Functionality includes anticipating future growth needs of the product. There is one area that drives both of these requirements directly from the start of the design – the development technology. Acquisition reform and the draw-down of Defense spending requires the Instrumentation Community to consider how they use their funding. Research has shown that only 40% of the lifecycle cost of a product occurs during development. The majority of the life cycle cost is in the recurring and supportability/maintainability areas. In order to keep the total cost of ownership low; we need to consider leveraging off developments and purchasing power available in other industrial areas – like the embedded PC market.

4 Alternatives

There seem to be four real alternatives in the technology to design and build a flight quality Fibre Channel Bus Monitor. The first three were chosen from basic industry awareness and looking through several issues of RTC magazine. RTC magazine specializes in embedded and real-time computer systems. As can be seen by the selection criteria, the goal was to get a product that was cost-effective, viable, and supportable. I ruled out concepts not supported by a standard, industry consortium, or were just emerging as standards. Custom design was added since they have been the option used in this industry for the past 30 years and should be considered.

4.1 PC/104 & PC/104+

PC-104 has been around for awhile. It is small formfactor board measuring approximately 4 inches square. Combinations of cards can be stacked on top of each other to gain greater functionality. PC/104 utilizes both 8 and 16 bit versions of the ISA bus (5 MB/s) for communication between the cards. As the bus throughput requirements increased, a PCI bus (132 MB/s) connector was added to the PC/104 card turning it into a PC/104+ card. Support for the PCI bus is limited to a bus width of 32 bits. The stacking concept is shown in **Figure 2**. Although PC/104 modules have been manufactured since 1987, a formal specification was not published until 1992. Like the original PC bus itself, PC/104 is thus the expression of a de facto standard rather than the invention and design of a committee. The PC/104 Consortium is responsible for maintaining the PC/104 and PC/104+ standards until the IEEE completes the proposed IEEE-P996.1 version.

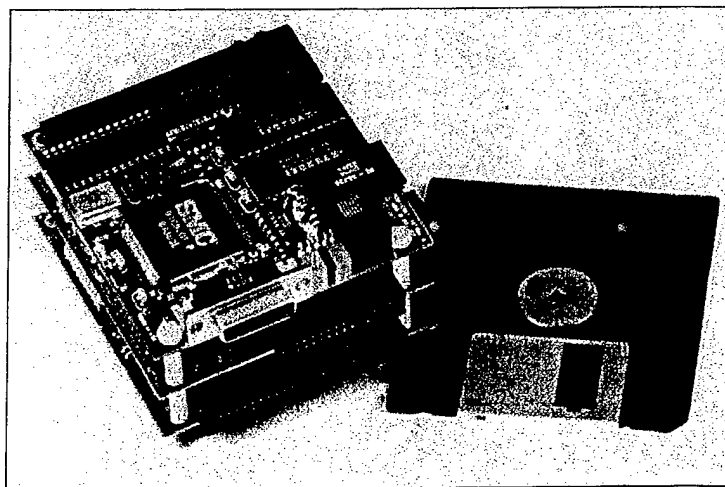

Figure 2 PC/104 Stack Example (3.6 x 3.8 inches)

4.2 PCI Mezzanine Card (PMC)

The PCI Mezzanine Card (PMC) has been around since 1994. It has increased market share and become the de facto large expansion module formfactor for VME (VersaModule Eurocard) and Compact PCI. It is approximately 30% larger than PC/104 measuring approximately 3 inches by 6 inches. The relatively large size of PMC for a mezzanine card was a great boon in the beginning. Now with entire boards being placed within a single chip, many PMC single function boards are overkill with large amounts of unused real estate. In specialized applications where conduction cooling and ruggedization typically require more space, the size may again be a strength. The bus I/O on the PMC card is a full 64 bit PCI bus operating at 66 MHz. PMC enthusiasts are also in work to create a new Processor PMC (P-PMC) variant by adding support for a processor on the card. PMC is governed by the standard IEEE-1386.1. Figure 3 shows an example of the PMC card.

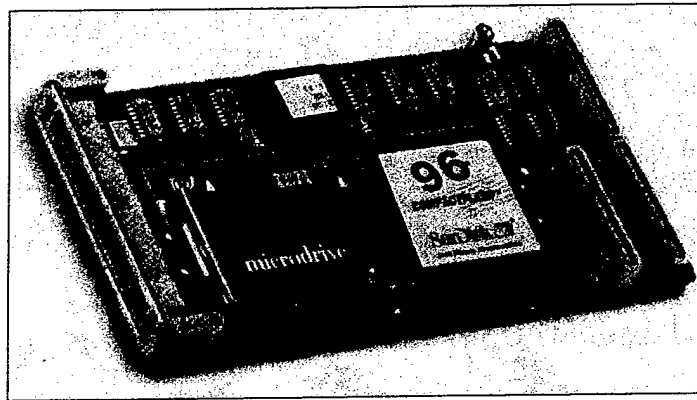

Figure 3 PMC Card Example (3 x 5.9 inches)

4.3 Industry Pack (IP)

The Industry Pack (IP) card was one of the first mezzanine cards. It was originally designed to solve space and I/O issues on a crowded VME card. The role of the mezzanine card has evolved to become one of flexibility. The card itself doesn't support the prevalent ISA and PCI busses. It's 8 bit 16 MB/s bus limits it's applicability to traditional industrial automation application types such as A/D conversion, motion control, and discrete I/O. Mil-Std-1553 and Arinc 429 applications seem to abound in this standard. Figure 4 shows an example of the IP card.

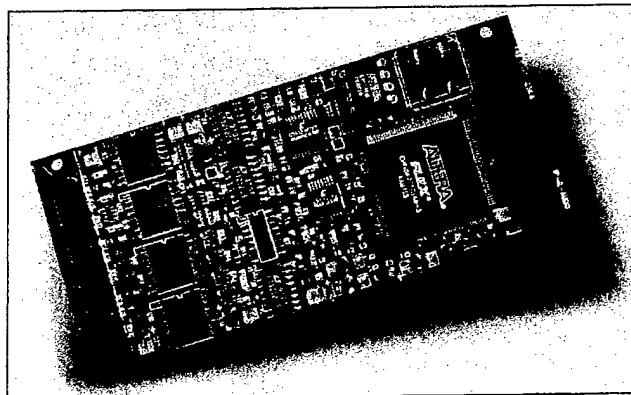

Figure 4 IP Card Example (1.8 x 3.9 inches)

4.4 Custom Design

This category can cover a large area. Technically any of the preceding categories that may need a special interface designed could be classified as custom. For the purposes of this trade study, the term 'custom design' will be used to indicate a substantially 'from scratch' design. The card size, connectors, busses, etc will all be chosen to favor the performance side of the cost/performance trade space.

5 Criteria

The criteria with which to select the bus tap method are listed in below. The scoring method and weightings are shown in Table 2. The utility relationship for each criterion is listed at the conclusion of each paragraph.

5.1 Backplane Bus Speed

The speed of the backplane is the single best indicator in determining the applicability of a technology in a data intensive application like this one. With Fibre Channel having a basic data rate of 100 MB/s, a very light data loading of 20% would require a minimum rate of 20 MB/s (assuming no overhead). Fibre Channel and other telecommunications standards are currently striving for 1000 MB/s rates. When these higher rates start showing up in the commercial markets, a technology that has room to grow as data requirements increase is critical. When a major weapons program was researched recently; it showed an exponential growth in data rate requirements over the last 20 years. There is no reason to indicate this will change now.

UTILITY: <20 MB/s ---- >500 MB/s {linear}

5.2 Technology Availability

The point of this product is to gather data from avionics Fibre Channel interfaces. In order to make this cost effective, commercial Fibre Channel bus adapters must be available. The availability of a Fibre Channel adapter will get a high score. In the absence of a Fibre Channel capability, the availability of another telecommunication or computer standard like Ethernet or Small Computer System Interface (SCSI) will get a medium score. The rationale is that it is conceivable product lines could be expanded to include Fibre Channel if they are already in the telecommunications or data storage market. For the custom design, a similar rationale applies concerning the capabilities of the development staff.

UTILITY: L – Any products M – Any telecom/storage H – Fibre Channel {discrete}

5.3 Environment / Ruggedability

One of the issues with using commercial products in a flight test environment is their susceptibility to the vibration and temperature extremes. The availability of products in a rugged format will be used to assess this criterion. A rugged format means less development work is spent trying to adapt it for use in a harsh environment. Based on the technology availability found in section 5.2, an assessment will be made as to the availability of a ruggedized capability. For example: If the IP alternative was found in 5.2 to have telecommunications products available and further research shows the most rugged version to be industrial grade – then as

shown in Table 4, the score would be '5'. By definition, the custom design will have a militarily rugged Fibre Channel solution.

Table 1 UTILITY Function for Environment / Ruggedability

Results from 5.2	Any Products			Telecom/Storage Products			Fibre Channel Products		
Most rugged product	C	I	M	C	I	M	C	I	M
Score	0	1	2	4	5	6	8	9	10
	C Commercial I Industrial M Military								

5.4 Supportability / User Base

Just as important as the purchase cost is the life cycle support cost. A major component to the life cycle cost is some measure of platform supportability. When an upgrade is required, will this platform still be in use? An indicator of future supportability is the size of the installed user base at the present. A larger user base now will provide the impetus for design upgrades. It also means more maintenance work that can be spread across more companies keeping the prices down. A sampling of vendors' products will be used to assess the current user base while adherence to commercial standards will help to predict the amount of future users. The custom design will be scored a 'low' by default, considering the size of the other markets.

UTILITY: L --- M --- H {discrete, relative to each other}

5.5 Size

Size is an important consideration in any test environment. Smaller size allows for easier installation when space is a premium. Larger units may require the removal of production equipment. The system under test may be affected without these production systems running. Calculating the size of a given design is difficult without actually doing the design. For this trade study, the individual card size will be used as the metric. For the custom design, an average sample of Mil-Std-1553 bus monitors will be used since their function is similar. While size is important and is why it is listed as a criterion to begin with, all of these technologies are of a reasonable size. This was given low weighting to provide an edge to the smaller of evenly matched choices, not to drive the decision.

UTILITY: >20 sq in ---- < 5 sq in {linear}

Table 2 Criterion Scoring and Weighting

Criterion	Units	Score	Weighting
Backplane Bus Speed	<20 MB/s ---- >500 MB/s {linear}	0-10	35%
Technology Availability	L - Any products M - Any telecom/storage products H - Fibre Channel {discrete}	0 / 5 / 10	25%
Environment / Ruggedability	Any products (C / I / M) Any telecom/storage products (C / I / M) Fibre Channel (C / I / M) C - Com I - Ind M - Mil {discrete}	0 / 1 / 2 4 / 5 / 6 8 / 9 / 10	20%
Supportability / User Base	L --- M --- H {discrete, relative}	0 / 5 / 10	15%
Size	>20 sq in ---- < 5 sq in {linear}	0-10	5%

6 Comparison

The alternatives were evaluated using the units listed in Table 2 and are summarized in Table 3. Each alternative was scored on a 10-point scale. The individual raw scores were multiplied by the weighting percentage and added together. The final weighted scores as shown in Table 3 have a possible high score of 10.

Table 3 Evaluation of Alternatives

Criterion	Units	PC/104+	PMC	IP	Custom
Backplane Bus Speed	MB/s	132	528	16	132 ^{Note 1}
Raw Score		2.3	10.0	0.0	2.3
Technology Availability	no units	M	H	L	L
Raw Score		5	10	0	0
Environment / Ruggedability	no units	T-M	F-M	A-M	F-M
Raw Score		6	10	2	10
Supportability / User Base	no units	M	H	M	L
Raw Score		5	10	5	0
Size	in ²	13.68	17.7	7.0	6.25 ^{Note 2}
Raw Score		4.2	1.5	8.7	9.1
Total Raw Score		22.5	41.5	15.7	21.5
Weighted Score (out of 10)		4.3	9.6	1.6	3.3

Note 1: It is assumed a custom design would utilize a 32 bit PCI bus or equivalent
 Note 2: Used common miniature data acquisition card size of 2.5x2.5.

7 Conclusion

PC/104 was the favorite going into the trade study due to the variety of products available. However PC/104 was hurt by its lack of Fibre Channel products. PMC not only had the ruggedized Fibre Channel boards, but had the most offerings of products in general. The notable exception is the lack of a single board computer (SBC) in the PMC formfactor. Any processing would have to be done on the carrier card. That should soon be remedied as there is work in the standards group to include a processor PMC board (called P-PMC). The Industry Pack choice was extremely disappointing. There is a fair amount of ruggedized Mil-Std-1553 boards available, but that seems to be about it. IP products were very hard to find. One of the big drawbacks for IP is the slow bus. There have been discussions in the standards body of mapping Compact PCI to the I/O on the IP card. The custom design is the old standby. It will do the job. The only question is...can we afford it? Based on these results, PMC is the better choice. It should be able to do the job with minimal 'glue' logic to tie the design together.

A sensitivity analysis was performed on the results to ensure the choice of either the utility curve or the weighting for a particular criterion did not affect the outcome between two or more closely matched alternatives. For this study, the top score was more than 50% of full scale above the closest challenger, which was a good overall indicator of insensitivity. To further check for sensitivity, each criterion was successively zeroed out. With the elimination of each successive criterion the order of the alternatives changed, but the winner remained constant. This shows one criterion did not drive the results. Table 4 shows the results of zeroing the criteria. For each criterion zeroed, read across the table for the results.

Table 4 Sensitivity Results

Criterion Zeroed	PC104	PMC	IP	VME
Backplane Bus Speed	5.0	7.9	3.9	4.8
Technology Availability	4.4	7.9	3.9	5.4
Environment / Ruggedability	4.1	7.9	3.4	2.9
Supportability / User Base	4.4	7.9	2.7	5.4
Size	4.6	10.0	1.8	3.1

8 References

- RTC Magazine, "Close Look at Small Formfactor Standard Products", August 2000, p20.
- RTC Magazine, "PC/104: The Embedded PC Mezzanine", November 2000, p64.
- Ibid, "Three Mezzanine Buses Lead the Parade", p70.
- PMC Fibre Channel card index, <http://www.dy4.com/products/datasheets/index.htm>
- IP Modules ANSI/VITA 4-1995, <http://www.commcon/main/ip-module.html>
- 1553B IP module data sheet, <http://www.alphitech.com>
- PC/104 Standard Overview, <http://www.adlogic-pc104.com/consp4.html>
- An Introduction to VME, <http://www.lecroy.com/lrs/appnotes/introvme.htm>

Appendix I

Interim Report

Fibre Channel Avionics Bus Monitor

Interim Report

**Johns Hopkins
System Engineering Project**

Course No. 645.770

Sid Jones
January 15, 2001

Ray Schulmeyer
Advisor

Table of Contents

1 DETAILED PROJECT DESCRIPTION

- 1.1 BACKGROUND
- 1.2 NEED FOR SYSTEM
- 1.3 PROJECT OBJECTIVES

2 PREVIOUS WORK

3 REQUIREMENTS ANALYSIS

- 3.1 STATEMENT OF NEED
- 3.2 OPERATIONAL CONCEPT DOCUMENT
- 3.3 EXTERNAL INTERFACE REQUIREMENTS
- 3.4 SYSTEM REQUIREMENTS

4 SYSTEM CONCEPT DEFINITION

5 TRADE STUDIES

- 5.1 BUS TAP METHOD
- 5.2 DEVELOPMENT TECHNOLOGY

6 UPDATED SCHEDULE

7 RISK STATUS UPDATE

APPENDIX A STATEMENT OF NEED

APPENDIX B OPERATIONAL CONCEPT DOCUMENT

APPENDIX C EXTERNAL INTERFACE REQUIREMENTS

APPENDIX D SYSTEM REQUIREMENTS

APPENDIX E TRADE STUDY – BUS TAP METHOD

APPENDIX F TRADE STUDY – DEVELOPMENT TECHNOLOGY

1 Detailed Project Description

1.1 Background

Traditionally, airframes were designed without any thought of ways to instrument them. Once the airframe was built, requirements were turned over to the flight test instrumentation department to find a way to monitor the data necessary for testing (the term "afterthought" comes to mind). This was not necessarily a bad thing – then. The economics was a 25 million-dollar instrumentation budget was noise to a multibillion-dollar development budget. During the past 8-10 years, that has begun to change for a couple of reasons. Defense dollars are diminishing and the airframes are becoming a lot more complex. The result has been a push-pull effect to integrate the test instrumentation engineers earlier in the program. The developer wants to pull the test instrumentation engineer in to save Test & Evaluation (T&E) costs. The test instrumentation engineer wants to push their way in due to the complexity of the systems that need monitoring.

The current state of the art has airframe developers augmenting the production avionics data buses with high-speed fiber optic networks (in many cases using Fibre Channel). As these fiber optic networks are being installed in airframes, the test instrumentation engineer will be expected to safely monitor the data flowing through them. Unlike many of the systems in the past, successful monitoring will require an engineering analysis long before any data is required. The timing for this project is perfect. Networks are now being put in several of the major airframes where the designs could be tweaked to facilitate the instrumentation system. These systems are far enough down the road that knowledge gained now will help the community prepare.

1.2 Need for System

Acquisition Reform has allowed the Department of Defense (DoD) to quickly integrate state of the art commercial products into the weapons platforms. One such area is the integration of network technology into the production avionics suite. There is a concern this is happening faster than the Test and Evaluation community can react with proper instrumentation practices and products.

For the past 20 years, the avionics bus used on military aircraft has been Mil-Std-1553 (1553). Because it utilized a 'bus architecture' where all devices are connected to a central cable, monitoring the bus data for Test & Evaluation purposes was relatively simple. Regardless of where the bus tap was made, all of the data was available as illustrated in Figure 1. The data requirements of today's aircraft are so large that it overwhelms the 1553 bus. For many airframe manufacturers Fibre Channel is the solution.

Fibre Channel is currently 4000 times faster than 1553 with plans to go faster. Fibre Channel operates in a point-to-point architecture. A node on the system will communicate through a port with only one other port. Special units called 'switches' receive data on one port and send data out on another port to create what the industry terms a 'fabric'. Figure 2 shows a typical switched fabric architecture used with Fibre Channel. The cloud represents the uncertainty as to where the bus tap would actually be made. The speed and architecture differences between 1553 and Fibre Channel require the instrumentation community to develop a new approach to capture bus data under this paradigm.

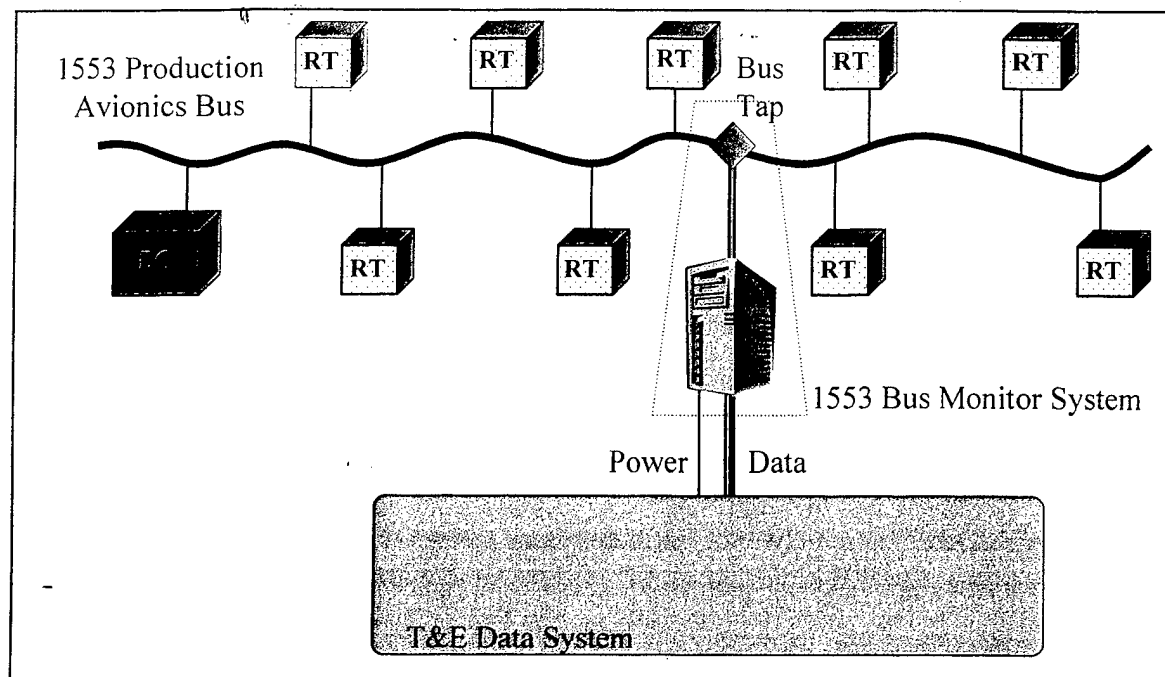

Figure 1 Monitoring 1553 (Bus Architecture)

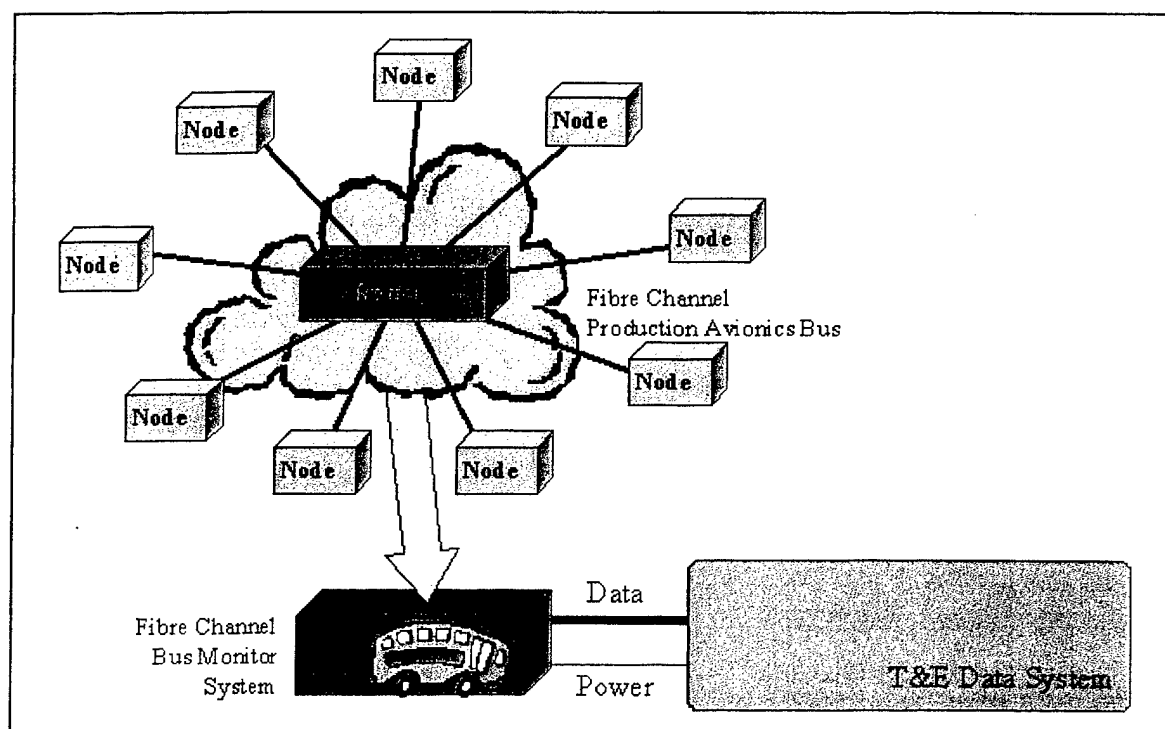

Figure 2 Monitoring Fibre Channel (Switched Fabric Architecture)

1.3 Project Objectives

Through this project, I expect to lay the groundwork for an avionics bus monitor development program. The final report will be submitted for release to the public. The A-Spec and other

supporting documents should prove useful for a company looking for a product to insert into their Internal Research and Development (IRAD) program. Alternately the results of this project could be used as a baseline for a Small Business Innovative Research (SBIR) project.

2 Previous Work

The issue of monitoring a networked avionics bus first came to light about two years ago. During that time, the Navy was leading a tri-service project on finding a fast commercial communications bus for the instrumentation community. After much research and a very rigorous 3-tiered trade study, Fibre Channel was announced as the likely solution. More information about Fibre Channel was needed so we started attending the bi-monthly Fibre Channel Standard working meetings. The sub-committee that held our interest was the Fibre Channel Avionics Environment (FC-AE). We were learning about the capabilities of Fibre Channel from a group intent on operating a Fibre Channel network in the same environment. We were ecstatic over the synergy that could be gained from a market as broad as Storage Area Networks (SAN) and the avionics group looking to make it more robust. It dawned on us that if successful; we would need to monitor the data on the bus. Discussions with the sub-committee members as to how they intended to monitor the data were the basis for many of the initial insights and options. One group in particular decided to use an instrumentation capable switch. Since they were the ones building the aircraft and selecting the data to monitor, they didn't have the same uncertainties we did as to the availability of the instrumentation ports or variability of the data requirements.

3 Requirements Analysis

A requirements analysis was performed which consisted of the following documents.

3.1 Statement of Need

A Statement of Need was produced as part of the requirements analysis. The need was addressed from the perspective of monitoring avionics data throughout the weapons platform lifecycle. This document was the result of personal experience, various discussions with personnel in the Fibre Channel Avionics community, and interviews with managers associated with the four major T&E ranges. The Statement of Need is included as Appendix A of this report.

3.2 Operational Concept Document

The operational concept document addresses four important topics in the discussions of a new or improved system.

- The state of the current system
- The concept envisioned for the new or improved system
- How the new system will be utilized
- Impacts the new system will have on current operations

The important point to come out of this document is the idea that Fibre Channel will not replace Mil-Std-1553 in military aircraft avionics systems. Instead, Fibre Channel will augment Mil-Std-1553 avionics systems. This is good news to the Test Ranges since it implies a more gradual shift towards fiber optics and Fibre Channel rather than an abrupt one. This does not alleviate the requirement for some operations personnel to get up to speed on this technology now, but does lessen the urgency for the majority. The Operational Concept Document is included as Appendix B of this report.

3.3 External Interface Requirements

There were two significant items that surfaced as a result of identifying the external interfaces. The first was the need to understand the Open System Interconnect (OSI) model. While no one actually builds systems using it, the OSI model is how most systems define or describe their model. The second item has to do with specifying interface standards. The common practice is to cite the current revision and allow for future ones. Typically the newer standards further define or tighten the older ones and therefore are backward compatible. When dealing with aircraft power standards, a similar result occurs – from the power producer perspective. From a power consumer perspective a device must be able to handle the worst power specification. In this case that means the oldest. For example, a newer power standard may allow 5-mV ripple instead of the previously allowed value of 100-mV. New products must handle power specifications all of the platforms it may be operated on. In this example, it must be designed to the older 100-mV ripple allowance. The External Interface Requirements document is included as Appendix C of this report.

3.4 System Requirements

The System Requirements document identifies several required states and modes of the Fibre Channel Bus Monitor. After the requirements were identified, a table was used to correlate the requirements to the states and modes that they apply. The System Requirements document is included as Appendix D of this report.

4 System Concept Definition

Collecting data from an avionics bus for T&E purposes has been going on for 20 years. However, there are three areas that make monitoring Fibre Channel avionics data different from the past: networks, optical fiber, and gigabit speeds. A bus monitor consists of two major sub-systems. The first is the actual interface to the production avionics system identified as a bus tap. The second is the main unit that receives, formats, and outputs the data.

Tapping into Mil-Std-1553 avionics busses over the past 20 years has been pretty simplistic. Mil-Std-1553 used a bus architecture which means that no matter where the physical tap is made, all data on the bus is available. It is then up to the main unit to filter out which data is not wanted and pass the rest on to the data system. Fibre Channel uses a point-to-point architecture. In a point-to-point architecture, data is only sent to the units that need it. Installing a tap on one leg of the Fibre Channel bus will collect data either going to or from that one unit.

There are some cases where a single point bus tap would work in a Fibre Channel network. It requires a couple of assumptions about the capability of various pieces of the avionics system. The most feasible of these concepts (the instrumentation capable switch) was included as part of the bus tap trade study. Some of these concepts involved fundamental changes to the avionics software loads that control the operation of the flight control systems. An example is establishing a well-known instrumentation port address and multicasting data of interest to include this address. This was considered to be unrealistic since the Operational Flight Program (OFP) would have to be reprogrammed which would require extensive regression testing to ensure the modifications didn't introduce new bugs and the additional data traffic wouldn't bog down the bus. These options were discarded due to the unnecessary risk factor and the inability to respond to changes in test requirements quickly.

The bus tap trade study indicated individual optical taps were the best single solution. This allows the system to capture bus data when the bus is being validated. Bus validation is the most stringent requirement since the data system must be independent of the system under test.

Figure 3 shows where the Fibre Channel Avionics Bus Monitor (inside red dashed box) fits into a T&E data system. This figure shows how the new Fibre Channel bus monitor would be a node on the data system network like the 1553 bus monitor and the other data acquisition nodes.

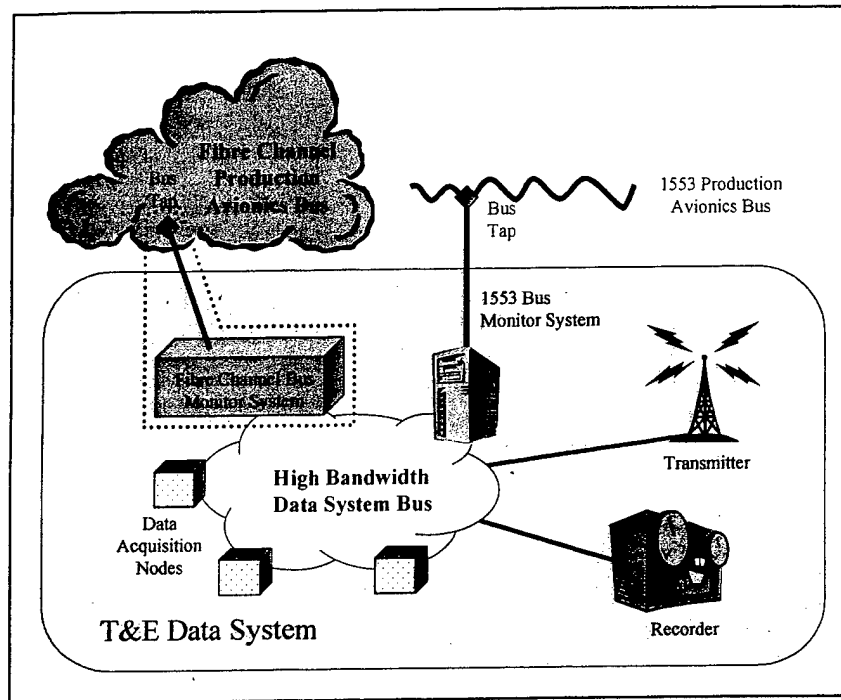

Figure 3 System Relationships

5 Trade Studies

5.1 Bus Tap Method

The Instrumentation Group is responsible for instrumenting any type of test platform in the Navy's inventory. Some of the advanced tactical aircraft are installing networked based fiber optic busses as avionics suite upgrades. Part of the flight test requirement is to collect data from these new busses. Since these networked based fiber optic busses haven't shown up in fleet assets yet, a method to tap into these busses for flight test has yet to be identified. Research indicates that initial installations of Fibre Channel Avionics Systems will utilize fiber optic cable. Since this is a more stringent requirement than purely electrical systems, monitoring busses with fiber optic cables will be the requirement. Four approaches were identified for tapping into a networked-based fiber optic bus for flight test use. Table 1 shows both the raw score and the weighted score from the study. For more information, the Bus Tap Method Trade Study is included as Appendix E of this report.

Table 1 Bus Tap Method Trade Study Results

Alternative	Raw Score (18 max)	Wt Score (3 max)
Developer's Approach	11	2.1
Individual fiber optic bus taps at each node	16	2.8
Replace production switch with instrumentation switch	13	2.4
Avionics switch with built-in instrumentation support	10	1.3

5.2 Development Technology

A Fibre Channel Bus Monitor must be both functional and cost effective. Functionality includes anticipating future growth needs of the product. There is one area that drives both of these requirements directly from the start of the design – the development technology. Acquisition reform and the draw-down of Defense spending requires the Instrumentation Community consider how they use their funding. Research has shown that only 40% of the lifecycle cost of a product occurs during development. The majority of the life cycle cost is in the recurring and supportability/maintainability areas. In order to keep the total cost of ownership low; we need to consider leveraging off developments and purchasing power available in other industrial areas – like the embedded PC market.

There seem to be four real alternatives in the technology to design and build a flight quality Fibre Channel Bus Monitor. The first three were chosen from basic industry awareness and looking through several issues of RTC magazine, which specializes in embedded and real-time computer systems. The goal was to get a product that was cost-effective, viable, and supportable. Concepts not supported by a standard, industry consortium, or were just emerging as standards were ruled out. Custom design was added since that has been the option used in this industry for the past 30 years. Table 2 shows both the raw score and the weighted score from the study. For more information, the Development Technology Trade Study is included as Appendix F of this report.

Table 2 Development Technology Trade Study Results

Alternative	Raw Score (50 max)	Wt Score (10 max)
PC/104 & PC/104+	22.5	4.3
PCI Mezzanine Card (PMC)	41.5	9.6
Industry Pack (IP)	15.7	1.6

6 Updated Schedule

	Est Hrs	Act Hrs	Aug	Sep	Oct	Nov	Dec	Jan
Write Concept	10	11	█					
Concept Approved	—	—		▼				
Proposal	15	18		█				
Draft Proposal Due	—	—		▼				
Project Proposal Due	—	—			▼			
Needs analysis	15	17		█				
Requirements Analysis	—	—						
Concept of Operations	13	25			█			
Identify external interfaces	8	16				█		
Gather data	8	0						
Identify/document processes	18	14		█	█			
Identify system requirements	10	16				█		
Identify data requirements	8	7				█		
Trade Studies	—	—						
Bus tapping method	29	23					█	
Development Technology	25	26.5					█	
Interim Report	12	6						█
Interim Report Due	—	—						▼
System Spec	29	0						█
Final Report	15	0						█
Oral Report	7	0						█
Final and Oral Report Due	—	—						▼
Total Hours	232	179.5						

7 Risk Status Update

		Prob	Severity
Risk	Interacting with new advisor	Low	Med
Mitigator	Face to face meeting; email/phone communication		
Status	<p>Open</p> <p>Technically, this risk is still open. However the relationship developed thus far into the project is working very well and is not expected to be a concern. Initially, the lack of face-to-face meetings was a concern. Email and phone conversations have proven to be adequate.</p>		
Risk	Not meeting user's needs and requirements	Med	Med
Mitigator	Interview users, provide draft documents to users for feedback		
Status	<p>Open</p> <p>During these days of "doing more with less", reviewing documents for other peoples projects not directly related to your own are low on the priority list. This was the case with my last project and so the meager feedback on this school project comes as no surprise. There have been only a couple of actual replies (both positive). Since I can't force people to read the document(s), the way I've chosen to get around this is from a proactive stance. I've gone out of my way to discuss the needs and requirements prior to writing the documents. The comments I received were on the Needs Statement.</p>		

		Prob	Severity
Risk	Not understanding operational environment		
Mitigator	Use previous bus monitors (1553) as a model; talk to knowledgeable people.		
Status	Closed The Operational Concept Document was a lot more in depth than was expected. As a result of the detail of the document, I think the operational environment is understood.		
Risk	Not understanding network aspect of avionics	Low	Med
Mitigator	Get knowledgeable people involved (fibre channel and avionics). Do research.		
Status	Open This risk was addressed primarily in the External Interfaces document. The only element remaining on this project is the A-Spec. Since the External Interfaces document feeds the A-Spec fairly directly, the probability drops to low (from High). Since the severity is Med, the risk will remain open to provide necessary visibility.		
Risk	Trade Study: Don't include viable option or don't throw out non-viable option		
Mitigator	Get knowledgeable people involved (fibre channel and avionics). Do research.		
Status	Closed Identified trade studies have been completed. If new options come to light or new trade studies need to be performed, this risk will be reopened.		
Risk	Fall behind on schedule due to workload, travel, family	Med	Low
Mitigator	Produce realistic schedule. Work to get ahead when possible. Identify critical path.		
Status	Open Underestimated how much averaging 18 hours a week on top of work actually was. Also underestimated effect of two major holidays. With the end in sight, believed current schedule can be maintained. There is some concern with work related travel schedules heating up in Jan/Feb.		
Risk	Unknown - unknowns	Med	Med
Mitigator	Perform risk assessment periodically. Keep looking for potential risk areas		
Status	Open This element to remain open through the end of the project.		

Appendix J

System Requirements Specification

Fibre Channel Avionics Bus Monitor

System Specification

Johns Hopkins
System Engineering Project

Course No. 645.770

Sid Jones
January 28, 2001

Ray Schulmeyer
Advisor

Table of Contents

1	SCOPE	1
1.1	IDENTIFICATION	1
1.2	SYSTEM OVERVIEW.....	1
1.3	DOCUMENT OVERVIEW	4
2	REFERENCED DOCUMENTS	4
2.1	PROJECT DOCUMENTS.....	4
2.2	REFERENCED DOCUMENTS.....	4
3	REQUIREMENTS.....	5
3.1	REQUIRED STATES AND MODES	5
3.2	SYSTEM CAPABILITY REQUIREMENTS	6
3.3	SYSTEM EXTERNAL INTERFACE REQUIREMENTS	9
3.4	SYSTEM INTERNAL INTERFACE REQUIREMENTS.....	14
3.5	SYSTEM INTERNAL DATA REQUIREMENTS	14
3.6	ADAPTATION REQUIREMENTS	15
3.7	SAFETY REQUIREMENTS.....	15
3.8	SECURITY AND PRIVACY REQUIREMENTS	15
3.9	SYSTEM ENVIRONMENT REQUIREMENTS	15
3.10	COMPUTER RESOURCE REQUIREMENTS	16
3.11	SYSTEM QUALITY FACTORS	16
3.12	DESIGN AND CONSTRUCTION CONSTRAINTS	16
3.13	PERSONNEL RELATED REQUIREMENTS.....	17
3.14	TRAINING RELATED REQUIREMENTS.....	17
3.15	LOGISTICS RELATED REQUIREMENTS.....	17
3.16	OTHER REQUIREMENTS	17
3.17	PACKAGING REQUIREMENTS	17
3.18	PRECEDENCE AND CRITICALITY OF REQUIREMENTS.....	17
4	QUALIFICATION PROVISIONS	17
5	NOTES	19
5.1	TERMS, ACRONYMS AND ABBREVIATIONS.....	19
	APPENDIX A: MIL-STD-704A TRANSIENT CHARACTERISTICS.....	21

List of Figures

FIGURE 1	SYSTEM RELATIONSHIPS.....	1
FIGURE 2	TYPICAL 1553 BUS MONITOR.....	2
FIGURE 3	SYSTEM RELATIONSHIPS.....	3
FIGURE 4	CONCEPTUAL BLOCK DIAGRAM.....	3
FIGURE 5	EXAMPLE CAPTURE DATA FORMAT, (A) VALIDATE MODE (B) TRUTH MODE.....	8
FIGURE 6	EXTERNAL SYSTEM INTERFACES.....	9

List of Tables

TABLE 1	REQUIREMENTS CORRELATION.....	6
TABLE 2	MAXIMUM DATA HEADER (WHEN NOT DEFINED IN IRIG 106).....	8
TABLE 3	EXTERNAL INTERFACES.....	9
TABLE 4	XIF-FC LAYERED MODEL.....	10
TABLE 5	XIF-FC RELATIONSHIP TO SYSTEM MODES.....	11
TABLE 6	XIF-DATA LAYERED MODEL.....	12
TABLE 7	XIF-DATA RELATIONSHIP TO SYSTEM MODES.....	13
TABLE 8	XIF-PWR RELATIONSHIP TO SYSTEM MODES.....	14
TABLE 9	SUMMARY OF DATA ELEMENTS.....	14
TABLE 10	QUALIFICATION METHODS.....	18

1 Scope

1.1 Identification

This document applies to a Fibre Channel Avionics Bus Monitor operated within a Data Acquisition Network. The Fibre Channel Avionics Bus Monitor is used to monitor Fibre Channel avionics busses located on weapons platforms for test and evaluation (T&E) purposes – primarily during developmental testing.

1.2 System Overview

A T&E Data System is used to acquire data during a test or mission. This data is recorded for post-flight analysis. The data may also be transmitted to a ground processing facility for in-flight data monitoring. As such, the T&E data system must be invisible to the operation and control of the aircraft. The T&E data system typically consists of independent wiring, data acquisition units, and oftentimes transducers. Upon completion of T&E, the system is removed and the aircraft is returned to fleet status. The data system may also be known as an instrumentation system or a telemetry system.

1.2.1 Background

For the past 20 years, the avionics bus used on military aircraft has been Mil-Std-1553 (1553). Much of the data sent across the 1553 bus is of interest to the test programs. As can be seen in Figure 1, a bridging system is used that gathers the data of interest from the production avionics system and formats the data into something useful for the T&E data system.

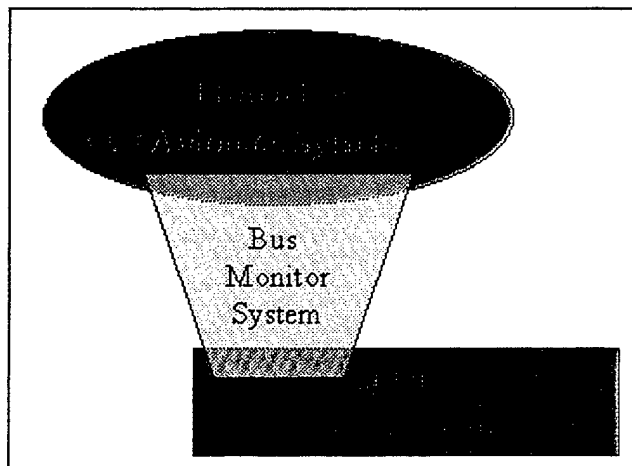

Figure 1 System Relationships

1553 utilizes a 'bus architecture' where all devices or remote terminals (RT) are connected to the bus controller (BC) via a central cable as shown in Figure 2. Regardless of where a unit is connected to the bus, all of the data on the bus is available to the unit. To interface to the 1553 bus, the bus monitor system used the same connection method listed in Mil-Std-1553 for the avionics units. The bus monitor was programmed to capture all of the data (100% mode) or specific data words (selected data mode).

Bus monitor systems are usually part of a larger T&E data system. The T&E data system is installed on the test vehicle to gather data describing the state of the test vehicle at any given moment. The data system will gather data from many different systems including both production and test systems. The data is transmitted, recorded or both.

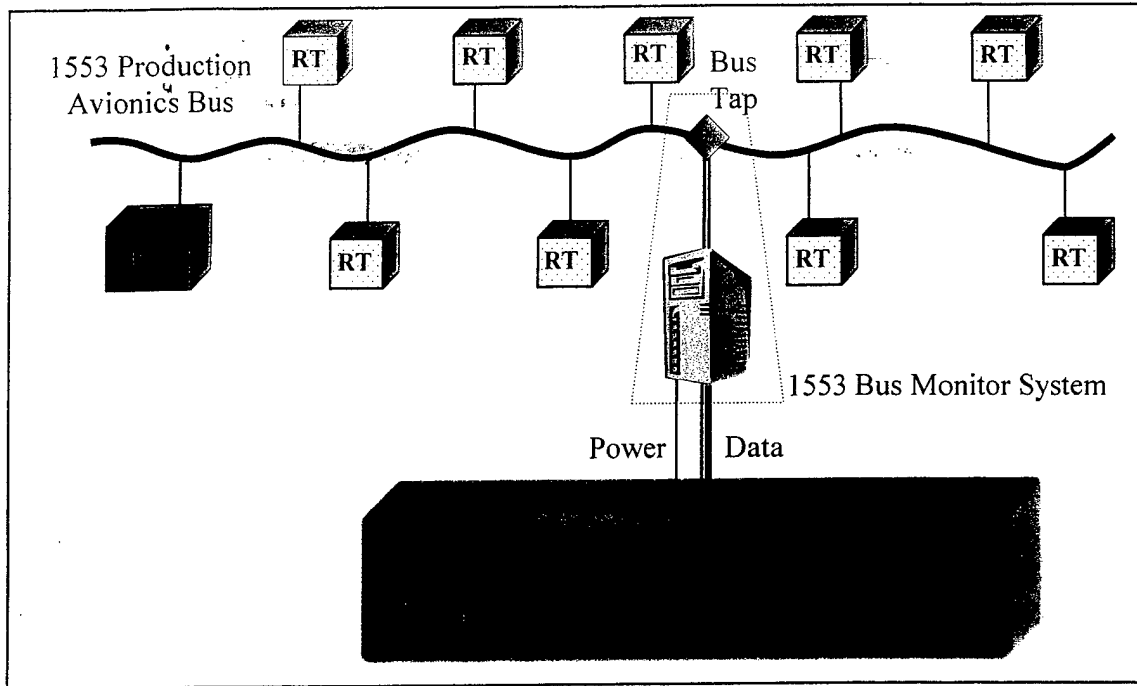

Figure 2 Typical 1553 Bus Monitor

As the 1 MHz rate of 1553 proves to be inadequate for today's data intensive avionics suites, avionics designers are turning to high speed, network based communication standards like Fibre Channel. At baud rates greater than 1 GHz, Fibre Channel should be able to handle the avionics data for years to come. At these rates, copper based wiring plants are no longer an option – fiber optics must be used.

1.2.2 Current Concept

The basic concept of tapping into the avionics bus to gather data for the T&E data system remains the same for Fiber Channel as it did for 1553. However, with speeds in excess of 1 Gb/s, network architectures, and fiber optic cabling plants new paradigms will have to emerge. For obvious risk issues, these new avionics busses will not replace the current 1553 avionics in a single step. Avionics sub-systems will gradually be converted as needs and funding arise. From the T&E Data System perspective, both 1553 and Fibre Channel Bus Monitors will be needed for the next few years at a minimum as can be seen in Figure 3. The bus monitor conceptually consists of two parts. The first part is the actual interface to the production avionics system identified as a bus tap. The second part is the unit that receives, formats, and outputs the data.

A conceptual block diagram of the Fibre Channel Bus Monitor unit is shown in Figure 4. The Fibre Channel interface receives avionics data from the bus tap in the Fibre Channel Avionics Network. The avionics message is time tagged via a time circuit that was synchronized from the T&E Data System. The comparator looks at the program memory for avionics messages of interest. If the message in the buffer was requested, it passes the message to the Output Message Formatter. The Formatter creates an output message based on whether the operational mode is 'Truth' or 'Validate'. Once complete, the output message is sent to the Data Interface where it enters the T&E Data Network. When in the Program State, T&E support unit talks to the Program Control through the Data Interface. The Program Control can read, load, verify, and

clear the non-volatile program memory. The Diagnostic Control receives status data from all subsystems. When in the operational state, a subset of the status words is available as status messages to the data system. When in the diagnostic state, a more thorough test is done which would interrupt the data collection during normal operations. The power for the unit is received from the T&E Data System.

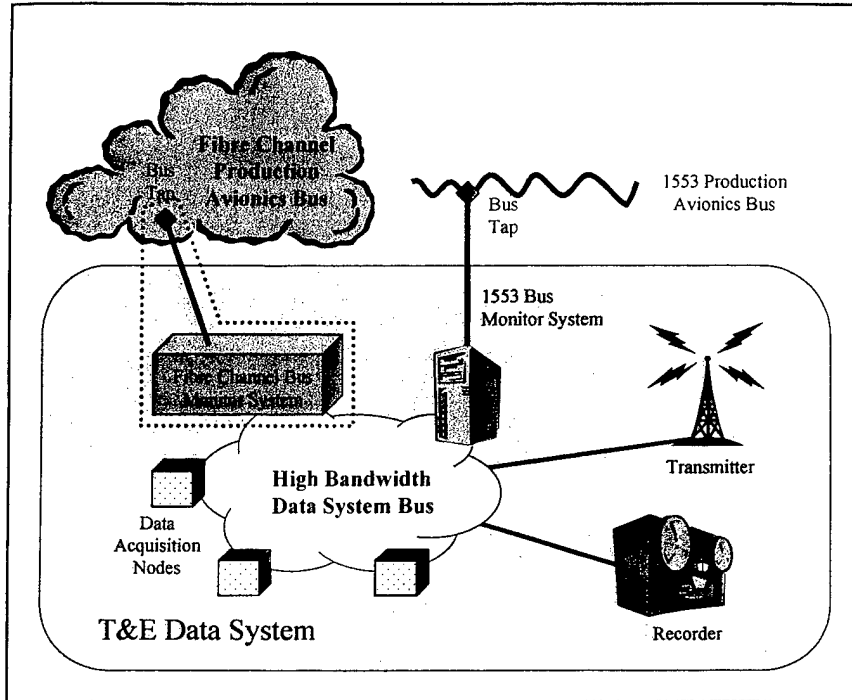

Figure 3 System Relationships

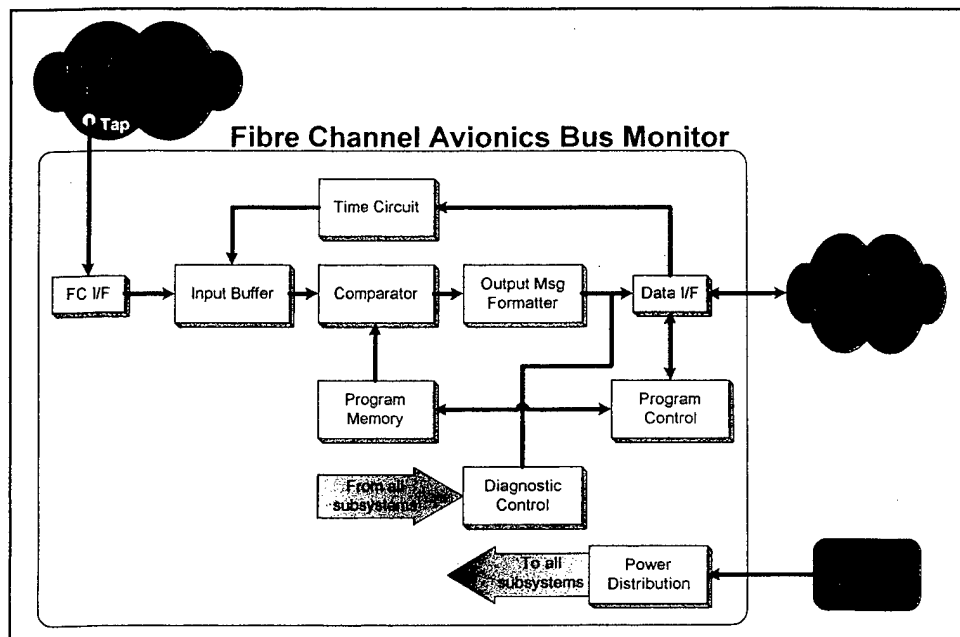

Figure 4 Conceptual Block Diagram

1.2.3 System Context

The primary users of this system will be the Instrumentation Departments at the major T&E centers including:

- Naval Air Weapons Center – Aircraft Division (Patuxent River)
- Naval Air Weapons Center, – Weapons Division (China Lake)
- Air Force Flight Test Center (Edwards AFB)
- Air Force Flight Development Center (Eglin AFB)
- Aberdeen Test Center (Army)

These T&E centers are all part of the Range Commanders Council (RCC) and support the Telemetry Standards published by the RCC. These standards drive the T&E Data System interface and data standards called out in this specification. These standards will change over time as requirements and capabilities change. There may also be other users desiring this capability whom use other standards. For these reasons, modular design practices should be considered.

Due to acquisition reform, the Government no longer desires to own product designs but wants to buy commercial products. Therefore there are no Government support agencies.

1.3 Document Overview

The purpose of this document is to provide the developer with a product concept the Government is interested in. Towards that end, this document will provide information about the minimum requirements for a Fibre Channel Avionics Bus Monitor. Additional capabilities, while always desired, must be balanced by the overall cost of the unit. The overall cost includes the per-unit purchase cost and the projected additional life-cycle cost.

Section 1 – General overview and scope of this specification.

Section 2 – Identifies project documents and specific issue of referenced documents.

Section 3 – Specifies the requirements for the Fibre Channel Bus Monitor

Section 4 – Details the qualification methods used to ensure compliance of the requirements in section 3.

Section 5 – Contains information pertinent to the understanding of this specification.

Appendices – Additional information in support of the previous sections.

2 Referenced Documents

2.1 Project Documents

<u>Document</u>	<u>Author</u>	<u>Date</u>
Statement of Need	Sid Jones	30-Oct-00
Operational Concept Document	Sid Jones	30-Oct-00
Bus Tap Trade Study	Sid Jones	7-Jan-01
Development Technology Trade Study	Sid Jones	7-Jan-01

2.2 Referenced Documents

The following documents of the exact issue shown form a part of this document to the extent specified herein. If a specification is referenced without indicating any specific paragraphs as being applicable, then the entire specification is applicable. Where a specific issue of the document is provided in Section 2.2, no other issue shall be used without the prior written

approval of procuring agent. When documents are referenced herein, a short form citing only the basic number of the document is used. Revision letters, amendment indicators, notices, supplements, and dates are omitted. If a document is invoked by reference in Sections 3 through 6, but not listed in Section 2, it is applicable. Existence of this situation should be called to the attention of the procuring agent. Subsidiary documents shall not be applied as requirements.

IRIG 106-01	Inter-Range Instrumentation Group Telemetry Standards, Range Commanders Council (RCC), 2001
Mil-Std-704A	Aircraft Electric Power Characteristics, 09-AUG-1966
Mil-Std-704E	Aircraft Electric Power Characteristics, 01-MAY-1991
Mil-Std-461E	Requirements For The Control Of Electromagnetic Interference Characteristics Of Subsystems And Equipment, 20-AUG-1999
Mil-Std-810F	Environmental Engineering Considerations And Laboratory Tests, 01-NOV-2000
ANSI X3.230-1994	Information Technology - Fibre Channel Physical and Signaling Interface (FC-PH), 1994
ANSI X3.297-1997	Information Technology - Fibre Channel Physical and Signaling Interface - 2 (FC-PH-2), 1997
ANSI X3.303-1998	Information Technology - Fibre Channel Physical and Signaling Interface - 3 (FC-PH-3), 1998
ANSI X3.nnn-200x*	Information Technology - Fibre Channel - Physical Interfaces (FC-PI)
ANSI X3.nnn-200x*	Information Technology - Fibre Channel - Framing and Signaling (FC-FS)
ANSI X3.nnn-200x	Information Technology - Fibre Channel - Virtual Interface Architecture Mapping Protocol (FC-VI)
ANSI X3.nnn-200x	Fibre Channel Avionics Environment Profile (FC-AEP) (due 8/01)
RFC-768	User Datagram Protocol (UDP), 28-Aug-80
RFC-2625	IP and ARP over Fibre Channel (IP), June 1999
SAE AS50881A	Wiring, Aerospace Vehicle, 15-Aug-98

3 Requirements

3.1 Required States and Modes

The unit shall have the following states as a minimum. Additional states or modes are allowed.

3.1.1 OFF

This state is characterized as having no power applied to the power input interface. There is no difference made to whether the unit is sitting on a storage shelf or wired in an operational configuration.

3.1.2 OPERATIONAL

This is the normal state of the unit. During this state, data from the Avionics Bus Monitor Interface (XIF-FC) is formatted based on internal program requirements for dissemination across the T&E Bus Interface (XIF-DATA). The interfaces are shown in **Figure 6**.

* FC-PI and FC-FS are currently in work and will supercede FC-PH, FC-PH-2, and FC-PH-3

3.1.2.1 *Validate Mode*

This mode is used when the quality of the production avionics data is suspect. Generally when using this mode, one or more of the avionics sub-systems are under test. The actual data values being sent are only half the story. Other equally important questions include: the state of the bus, which node sent the data and when, and which nodes received the data and when.

3.1.2.2 *Truth Mode*

This mode is used when the production avionics data is known to be good. The avionics data was previously validated and is now considered the truth source in validating other systems. During this mode, only the data is of concern – not the state of the bus.

3.1.3 PROGRAM

When in the program state, the unit is receiving instructions across the T&E Bus Interface (XIF-DATA) and storing them in non-volatile memory for execution during the Operational state.

3.1.4 DIAGNOSTIC

The diagnostic state allows the user access to all areas of memory through the XIF-DATA interface.

3.1.5 Requirements Correlation

Table 1 correlates the requirements listed in section 3.2 with the states and modes listed in section 3.1. The requirements apply to the states and modes as indicated.

Table 1 Requirements Correlation

Requirement	States and Modes				
	Off	Operational		Program	Diagnostic
		Validate	Truth		
Fibre Channel Avionics Bus					
Interference with avionics operation	✓	✓	✓	✓	✓
Number of Avionics Interfaces		✓	✓		
Number of Bus Messages		✓	✓		
Number of Data Words		✓	✓		
T&E Data System					
T&E Data System Compatibility		✓	✓	✓	✓
Validate Mode Data Format		✓	✓		
Truth Mode Data Format		✓	✓		
Selected Data			✓		
Data Header Format		✓	✓		
Time Tagging		✓	✓		
Power		✓	✓	✓	✓
Programming ports				✓	
Software				✓	

3.2 System Capability Requirements

3.2.1 Fibre Channel Avionics Bus

3.2.1.1 *Avionics Interface*

Individual avionics interfaces (bus tap) at each node shall be used. Regardless of the state of the unit and avionics interface, operation of the avionics bus shall not be compromised.

3.2.1.2 Number of Avionics Interfaces

The amount of data that can be monitored is limited by the output bandwidth of the unit. A single Fibre Channel interface may consume the entire output bandwidth available. However, due to the point-to-point nature of Fibre Channel communications, data may be required from multiple nodes. In a system with two mission computers connected to redundant switches, the minimum requirement will be to monitor both receive lines from both switches to each mission computer or four interfaces. The unit shall accommodate 1 to n avionics input interfaces, where $n \geq 4$.

3.2.1.3 Number of Bus Messages

Fibre Channel avionics systems are only now being developed. In the absence of hard numbers for the quantity of bus messages available, the number of Mil-Std-1553 messages (2^{16}) will be used as a starting point. The unit shall be programmable to select up to 65536 individual messages.

3.2.1.4 Number of Data Words

Mil-Std-1553 allowed as many as 32 data words per message. Theoretically, there is no limit on the number of data words allowed in a given message. It is expected that practical matters of command and control as well as Fibre Channel frame size will yield a data word per message limit of less than 1024. Any number of words within a given message shall be selectable for data acquisition.

3.2.2 T&E Data System

3.2.2.1 T&E Data System Compatibility

The current DoD data system standard is the Common Airborne Instrumentation System (CAIS). To meet future requirements, the Range Commanders Council (RCC) has identified Fibre Channel as the basis for the next generation data system. The T&E data system interface shall be CAIS or Fibre Channel as defined in IRIG 106.
Note: Good design and marketing practices would allow for a modular interface that could be swapped out for either interface desired.

3.2.2.2 Validate Mode Data Format

Validate mode is used when the bus data is being tested and therefore not a source of truth data. When in Validate mode, other information besides the data shall be captured. It is expected that all messages will be transferred within a single Fibre Channel frame. The entire Fibre Channel frame shall be time tagged and encapsulated as the data payload (less the start and end of frame identifiers). An example is shown in Figure 5 (A).

3.2.2.3 Truth Mode Data Format

Truth mode is used when the bus data is being used as a truth source. The data is believed to be accurate. When in Truth mode, only the time tag and message data shall be sent across the T&E interface. An example is shown in Figure 5 (B).

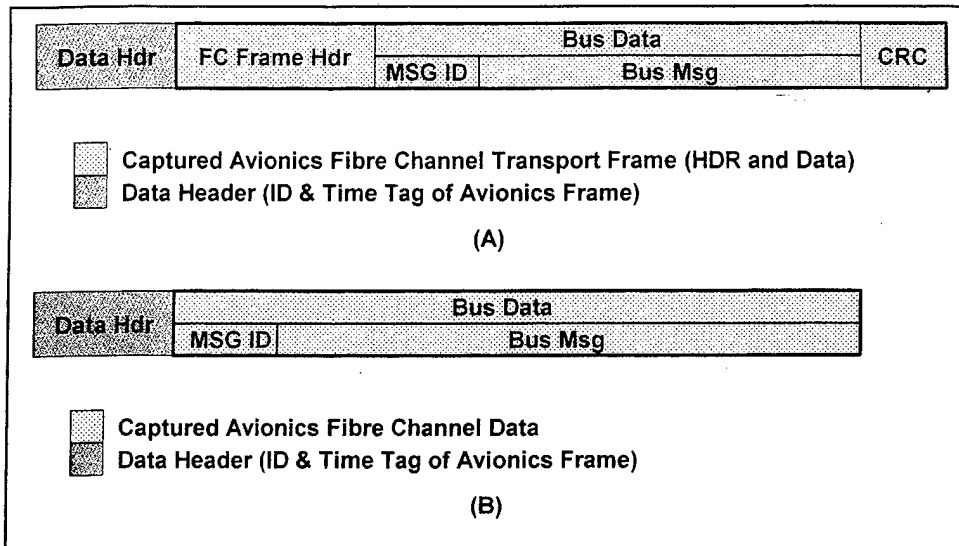

Figure 5 Example Capture Data Format, (A) Validate Mode (B) Truth Mode

3.2.2.4 Selected Data

Both sections 3.2.2.2 and 3.2.2.3 refer to capturing entire bus messages. When in Truth Mode, the option of capturing specific data word(s) within a message shall also be available. The selected data shall be placed within 1 or more user-defined messages. The system shall handle a minimum of 256 user-defined messages of 1024 words each.

3.2.2.5 Data Header Format

There is work underway within the Range Commanders Council for definition of data system message formats to be published in IRIG 106 at the time this specification was written. When this system is developed, message definitions found in the latest version of IRIG 106 shall be used. If IRIG 106 message definitions are not available, the data header shall be a maximum size consisting of the following fields: an 8 bit type field, a 16 bit ID field, and a 48 bit time field as shown in Table 2. The system shall be flexible enough to create subsets of the maximum header, for example: a 4 bit type field, an 11 bit ID field and a 36 bit time field.

Table 2 Maximum Data Header (When Not Defined in IRIG 106)

8b	16b	48b	i bits	i bits
TYPE	ID	TIME		
1H - Validate Data		Uniquely identifies the format of the message body		
2H - Truth Data		TIME		
3H - Selected Data		Time of first bit of first word of message body		

3.2.2.6 Time Tagging

Time correlation of acquired avionics bus data is accomplished by internal time counters and time tagging circuits, which are synchronized to the network time broadcast across the T&E data system. Accuracy of the time tag shall be 1.0 microseconds or better. The resolution of the time tag shall be 0.10 microseconds or better. The time format shall be in accordance with IRIG 106.

3.2.2.7 Power,

The unit shall operate from Mil-Std-704E 28VDC power with transient characteristics in accordance with figure 9 (curves 1&4) and figure 17 from Mil-Std-704A.

3.2.2.8 Programming ports

Programmability of the unit shall be done through the T&E Data System Bus (XIF-DATA) Interface. Additional program ports such as RS-232 and Ethernet are allowed but shall not limit XIF-DATA programming.

3.2.2.9 Software

Software shall be provided that will allow all modes and capabilities of the system to be exercised. The software shall operate on the following computer platform

- Microsoft Windows 2000 Operating System
- Intel Pentium 4, 1 GHz microprocessor
- 128 MB of system memory
- 17 inch monitor
- 800 x 600 video resolution using 65 thousand colors
- 40 GB Hard drive
- Sound Blaster compatible sound card with speakers
- 101 key – keyboard

3.3 System External Interface Requirements

3.3.1 Interface Identification and Diagrams

There are three external interfaces for the Fibre Channel Avionics Bus Monitor System – The Fibre Channel (FC) Avionics Bus, The Test and Evaluation (T&E) Data System Bus, and T&E Data System Power. Table 3 identifies these interfaces along with their associated project unique identifier (PUID), interfacing entities, and interface characteristics. Characteristics identified as ‘primary’ impose their requirements on other interfacing entities. Conversely, interfaces identified as ‘secondary’ have requirements imposed on them by the interfacing entity. The interfaces are shown graphically in Figure 6 and will be discussed in the succeeding sections.

Table 3 External Interfaces

Name	PUID	Interfacing Entities	Characteristics
FC Avionics Bus I/F	XIF-FC	Production Avionics Bus	Secondary, Input
T&E Data System Bus I/F	XIF-DATA	COTS Data System Bus	Secondary, Bi-directional
T&E Data System Power I/F	XIF-PWR	Data System Power Distribution	Secondary, Input

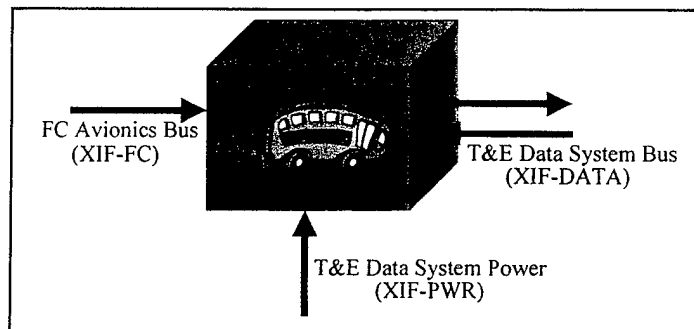

Figure 6 External System Interfaces

3.3.2 Fibre Channel Avionics Bus I/F (XIF-FC)

3.3.2.1 Purpose

This interface provides avionics data transfer from the production avionics bus to the bus monitor.

3.3.2.2 Description

Messages from the Fibre Channel Avionics Bus will traverse this interface. This message will be encapsulated using transport, network, and data link protocols decided upon by the avionics designer as shown in Table 4. The Fibre Channel interface will have to adhere to the same Fibre Channel standards used by the avionics system. At the top level, the standards would be the ANSI standards as listed in section 3.3.2.10. These standards are expected to be modified by the ANSI Fibre Channel Avionics Environment Profile. A manufacturer or platform specific report may further modify the Fibre Channel standard used by the avionics. The implication to this interface is that it must be configurable to accommodate these potential differences. Layered on top of the Fibre Channel are the network and transport protocols. Again, these may be different for various manufacturers and platforms

Table 4 XIF-FC Layered Model

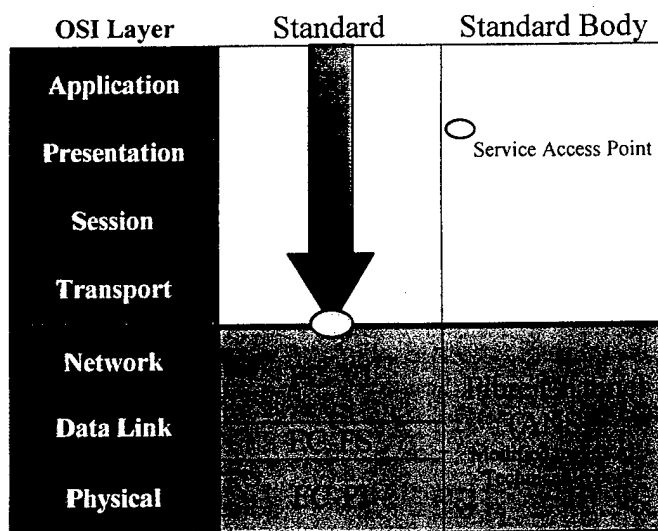

3.3.2.3 Priority

The system shall assign a high priority to this interface. All data of interest must be captured.

3.3.2.4 Type

This shall be a real-time interface.

3.3.2.5 Characteristics of Incoming Data Elements

Name	FC Avionics Bus Data
Source	Production FC Avionics Bus
Data Type	Payload
Size/Format	As defined in section 0

PUID	DI-FC
Units	Not Applicable
Range	Not Applicable
Accuracy	Not Applicable

3.3.2.6 Characteristics of Outgoing Data Elements

There shall be no outbound communication through XIF-FC.

3.3.2.7 Characteristics of Communications Methods

The communications methods that shall be used are defined by the reference documents in section 3.3.2.10

3.3.2.8 Characteristics of Protocols

The protocols that shall be used are identified in Table 4 and are defined by the reference documents in section 3.3.2.10

3.3.2.9 Relationship to System Modes

The following table shows the relationship of the Fibre Channel Avionics Interface to the modes of the system.

Table 5 XIF-FC Relationship to System Modes

Mode: OFF When the system is in the 'OFF' state, i.e. powered down, there is no activity on the interface. The interface method shall not interfere with normal avionics operation when the bus monitor is powered off.
Mode: OPERATIONAL - During OPERATIONAL mode, the interface is active. Data appearing on the avionics bus is sent across the interface where the system decides to send it forward or throw it away.
Mode: PROGRAM During PROGRAM mode, the interface is not active. The interface method shall not interfere with normal avionics operation when the bus monitor is in PROGRAM mode.
Mode: DIAGNOSTIC During DIAGNOSTIC mode, the interface is not active. The interface method shall not interfere with normal avionics operation when the bus monitor is in DIAGNOSTIC mode.

3.3.2.10 XIF-FC Reference Documents

FC-PH	FC-PI
FC-PH-2	FC-FS
FC-PH-3	FC-VI
FC-AEP	

For specific issue information, see section 2.2

3.3.3 T&E Data System Bus (XIF-DATA)

3.3.3.1 Purpose

This interface outputs formatted avionics bus messages transferred from the bus monitor system to the T&E Data System as well as receives system programming information.

3.3.3.2 Description

In the near future, the T&E Data System Bus is expected to migrate to a Fibre Channel based system as defined in the ANSI Fibre Channel Standards and modified by the IRIG (Interrange Instrumentation Group) Telemetry Standards Part II as shown in Table 6. The interface will reside in the bus monitor and be perceived by the data system as another node.

Table 6 XIF-DATA Layered Model

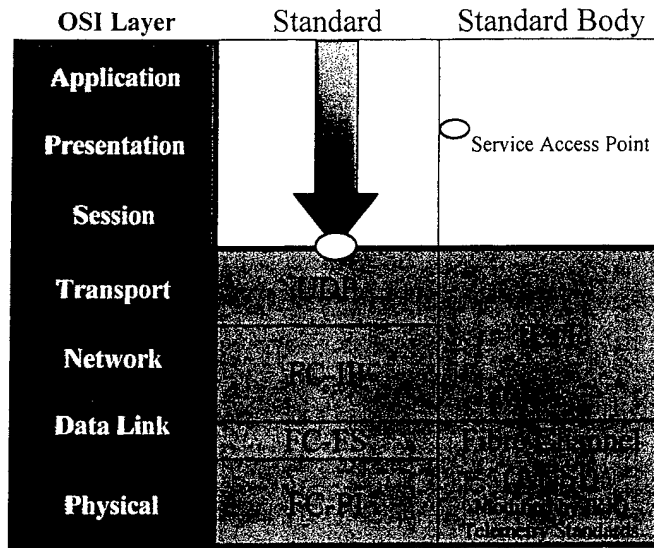

3.3.3.3 Priority

The system shall assign a medium priority to this interface.

3.3.3.4 Type

This shall be a real-time interface.

3.3.3.5 Characteristics of Incoming Data Elements

Name	System Programming Data	PUID	DI-SPD
Source	T&E Data System Support Unit	Units	Not Applicable
Data Type	Payload	Range	Not Applicable
Size/Format	TBD	Accuracy	Not Applicable

3.3.3.6 Characteristics of Outgoing Data Elements

Name	T&E Formatted Avionics Data	PUID	DO-FAD
Source	Internal	Units	Not Applicable
Data Type	Payload	Range	Not Applicable
Size/Format	As defined in section 3.3.3.10	Accuracy	Not Applicable

3.3.3.7 Characteristics of Communications Methods

The communications methods that shall be used are defined by the reference documents in section 3.3.3.10

3.3.3.8 Characteristics of Protocols

The protocols that shall be used are identified in Table 6 and are defined by the reference documents in section 3.3.3.10

3.3.3.9 Relationship to System Modes

The following table shows the relationship of the T&E Data System Interface to the modes of the system.

Table 7 XIF-DATA Relationship to System Modes

Mode: OFF	When the system is in the 'OFF' state, i.e. powered down, there is no activity on the interface.
Mode: OPERATIONAL	During OPERATIONAL mode, the interface is active. Avionics data is formatted and given a destination address within the T&E data system. The data flow across the interface is primarily from the bus to the T&E system in the form of avionics data. There may be some command activity being received by the interface from the T&E system.
Mode: PROGRAM	During PROGRAM mode, the interface is receiving data from the T&E system and stores the data in non-volatile program memory. Data being transmitted across the interface will be limited to program acknowledgement type of data.
Mode: DIAGNOSTIC	- During DIAGNOSTIC mode, the interface is transmitting internal diagnostic data from throughout the bus monitor to the T&E Data System. There may be some command activity being received by the interface from the T&E system

3.3.3.10 XIF-DATA Reference Documents

IRIG 106	FC-PI
FC-PH	FC-FS
FC-PH-2	IP
FC-PH-3	UDP
FC-AEP	

For specific issue information, see section 2.2

3.3.4 T&E Data System Power (XIF-PWR)

3.3.4.1 Purpose

This interface provides the power needed to run the Fibre Channel Avionics Bus Monitor.

3.3.4.2 Description

The T&E Data System will provide the power required to run the Fibre Channel Avionics Bus Monitor. The T&E data system shall distribute raw aircraft power or regulated power. This allows a master switch to shut down the entire data system.

3.3.4.3 Priority

The system shall assign a moderate priority to this interface.

3.3.4.4 Type

This is a non-data interface.

3.3.4.5 Characteristics of Incoming Elements

Name	T&E Data System Power	PUID	DI-PWR
Source	Production FC Avionics Bus	Units	Volts
Data Type	Power	Range	22.0 to 29.0 steady state
Size/Format	Not Applicable	Ripple	1.5 max
Governing Standard	28Volts as defined in Mil-Std-704E	Transient	Transient response as defined in Mil-Std-704A (fig 9 curves 1&4 and fig 17)

3.3.4.6 Characteristics of Outgoing Elements

There shall be no outbound elements through XIF-PWR.

3.3.4.7 Characteristics of Communications Methods

Not Applicable

3.3.4.8 Characteristics of Protocols

Not Applicable

3.3.4.9 Relationship to System Modes

Table 8 shows the relationship of the T&E Data System Power Interface to the modes of the system.

Table 8 XIF-PWR Relationship to System Modes

Mode: OFF When the system is in the 'OFF' state, i.e. powered down, there is no activity on the interface.
Mode: OPERATIONAL During OPERATIONAL mode, the interface is active. 28 VDC is supplied to the Bus Monitor.
Mode: PROGRAM During PROGRAM mode, the interface is active. 28 VDC is supplied to the Bus Monitor.
Mode: DIAGNOSTIC During DIAGNOSTIC mode, the interface is active. 28 VDC is supplied to the Bus Monitor.

3.3.4.10 Reference Documents

Mil-Std-704A*

Mil-Std-704E

* This document is no longer available. Transient characteristics are supplied in the appendix for completeness.

For specific issue information, see section 2.2

3.3.5 Summary of Data Elements

Table 9 Summary of Data Elements

IF ID	IF Name	Element ID	Element Name
XIF-FC	Fibre Channel Avionics Bus Interface	DI-FC	Fibre Channel Avionics Bus Data
XIF-DATA	T&E Data Systems Bus	DI-SPD	System Programming Data
		DO-FAD	T&E Formatted Avionics Data
XIF-PWR	T&E Data System Power	DI-PWR	Bus Monitor Power
<i>XIF - External Interface</i>		<i>D - Data Element; I - Input; O - Output</i>	

3.4 System Internal Interface Requirements

There are no internal interface requirements identified for this system.

3.5 System Internal Data Requirements

There are no internal data requirements identified for this system.

3.6 Adaptation Requirements

3.6.1 Avionics Compatibility

The Fibre Channel standard does not guarantee interoperability. Given the absence of a Fibre Channel Avionics standard, it is envisioned that manufacturers of different platforms may design their Fibre Channel avionics network differently. This unit shall be configurable to accommodate multiple Fibre Channel avionics approaches. Configurability may include software programmability, personality module replacement, or other design approach that allows the user to reconfigure the unit for a specific application. Configuring the system between Fibre Channel avionics systems that are in operation at time of award shall not require more than 25% additional cost.

3.7 Safety Requirements

3.7.1 Explosive Atmosphere

The equipment shall not cause ignition of an ambient-explosive-gaseous mixture with air when operating in such an atmosphere.

3.8 Security and Privacy Requirements

There are no security and privacy requirements for the system. Security requirements are levied against the storage and telemetry systems.

3.9 System Environment Requirements

Unless otherwise specified, the bus monitor shall conform to the requirements when subjected to the environmental conditions listed below.

3.9.1 Storage Temperature

-55°C to +100°C

3.9.2 Operating Temperature

The thermal design shall take into consideration ambient air using convection and radiation only. Forced air and heat sinking shall not be required.

-40°C to +85°C

3.9.3 Pressure Altitude

-1000 feet to +85,000 feet

3.9.4 Temperature/Altitude

Combined conditions of +85°C and 85,000 feet

3.9.5 Relative Humidity

99 percent, condensing

3.9.6 Vibration

- 5 to 14 Hz at 0.20 inch double amplitude
- 14 to 20 Hz at 0.10 inch double amplitude
- 20 to 33 Hz at 2g acceleration
- 33 to 74 Hz at 0.036 inch double amplitude
- 74 to 2000 Hz at 10g acceleration

3.9.7 Shock

3.9.7.1 Crash Worthiness

Peak Acceleration: 40g, each axis

Method 516.4, procedure 5

3.9.7.2 Operational

Peak acceleration: 20g

Duration: 6 to 9 milliseconds

Axis: all axes

Method 516.4, procedure 1.

3.9.8 Electromagnetic Compatibility Limits

Conducted Emission (CE03), Radiated Emissions (RE02) and Radiated Susceptibility (RS03) per MIL-STD-461C.

3.9.9 Sand and Dust

The equipment shall withstand, in both operating and non-operating condition, exposure to sand and dust particles as outlined in MIL-STD-810E.

3.9.10 Fungus

The equipment shall withstand, in both operating and non-operating condition, exposure to fungus growth as encountered in tropical climates. In no case shall overall spraying of the equipment be necessary. If it can be shown non-nutrient materials are used, fungus test may be accomplished by analysis.

3.9.11 Salt Atmosphere

The equipment shall withstand, in both operating and non-operating condition, exposure to salt-sea atmosphere.

3.10 Computer Resource Requirements

There are no additional computer resource requirements that have not already been identified elsewhere in this document.

3.11 System Quality Factors

3.11.1 Reliability

Reliability shall be measured in Mean Time Between Failures (MTBF). The Fibre Channel Avionics Bus Monitor system shall have an MTBF greater than 1000 hours.

3.11.2 Maintainability

Maintainability shall be measured in Mean Time To Repair (MTTR). The Fibre Channel Avionics Bus Monitor system shall have an MTTR less than 30 minutes. Repair shall be limited to identification and replacement of the appropriate shop replaceable assembly (SRA).

3.12 Design and Construction Constraints

3.12.1 Size

Due to small spaces available in tactical aircraft for instrumentation, the bus monitor shall be no larger than 256 in³ exclusive of mounting tabs and mating connectors.

3.12.2 Weight

Given the size requirements in 3.12.1, weight is not an issue.

3.12.3 Mounting

Due to small spaces available in tactical aircraft for instrumentation, the bus monitor shall have all connectors located on one face.

3.12.4 Connectors

The connectors used by the bus monitor shall be EMI shielded and have a positive lock mechanism. Connector choice and input/output design shall adhere to SAE AS50881.

3.12.5 Color

The color of the bus monitor shall be orange to identify it as test equipment.

3.13 Personnel Related Requirements

3.13.1 Connectors

The spacing of the connectors shall be adequate for mating and unmating as defined in SAE AS50881.

3.13.2 Power

The power supply shall be reverse polarity protected.

3.14 Training Related Requirements

3.14.1 Help Screens

Training requirements on the system shall be limited to context sensitive help screens on the software user's interface. The help screens shall be sufficiently detailed that a high school graduate that has prior experience with bus monitor systems can operate the system.

3.15 Logistics Related Requirements

As this is a commercial product, there are no logistics related requirements.

3.16 Other Requirements

3.16.1 Technical Manuals

The technical manual shall be organized from a functional perspective. A section allocating the functions to the physical hardware or software shall also be provided. The technical manuals shall be written to a high school graduate level.

3.17 Packaging Requirements

The system shall be packaged to withstand shipping by commercial carriers.

3.18 Precedence and Criticality of Requirements

This system shall be approached from a life cycle cost perspective. The trade-offs between initial cost, performance, and reliability shall be made based on a 10-year life span. It is expected by that time, avionics capabilities will have changed sufficiently to require major upgrades or redesigns of the bus monitor system.

The requirement in section 3.2.1.1, Avionics Interface concerning not compromising normal avionics operations is considered a critical requirement. The test plan for this item shall be approved by the Government.

4 Qualification Provisions

The following qualification methods shall be used to ensure the requirements have been met as listed in Table 10.

- Demonstration The operation of the system, or a part of the system that relies on observable functional operation not requiring the use of instrumentation, special test equipment, or subsequent analysis.
- Test The operation of the system, or a part of the system, using instrumentation or other special test equipment to collect data for later analysis.
- Analysis The processing of accumulated data obtained from other qualification methods.
- Inspection The visual examination of system components, documentation, etc.

Table 10 Qualification Methods

Paragraph/ Title	Demo	Test	Analysis	Insp
3.1 Required States and Modes				
3.1.1 OFF	✓			
3.1.2 OPERATIONAL	✓			
3.1.2.1 Validate Mode	✓			
3.1.2.2 Truth Mode	✓			
3.1.3 PROGRAM	✓			
3.1.4 DIAGNOSTIC	✓			
3.1.5 Requirements Correlation	✓			
3.2 System Capability Requirements				
3.2.1 Fibre Channel Avionics Bus				
3.2.1.1 Avionics Interface		✓		
3.2.1.2 Number of Avionics Interfaces		✓		
3.2.1.3 Number of Bus Messages			✓	
3.2.1.4 Number of Data Words			✓	
3.2.2 T&E Data System				
3.2.2.1 T&E Data System Compatibility	✓			
3.2.2.2 Validate Mode Data Format			✓	
3.2.2.3 Truth Mode Data Format			✓	
3.2.2.4 Selected Data			✓	
3.2.2.5 Data Header Format			✓	
3.2.2.6 Time Tagging		✓		
3.2.2.7 Power		✓		
3.2.2.8 Programming ports	✓			
3.2.2.9 Software	✓			
3.3 System External Interface Requirements				
3.3.1 Interface Identification and Diagrams				✓
3.3.2 Fibre Channel Avionics Bus I/F (XIF-FC)		✓		
3.3.3 T&E Data System Bus (XIF-DATA)		✓		
3.3.4 T&E Data System Power (XIF-PWR)		✓		
3.3.5 Summary of Data Elements		✓		
3.4 System Internal Interface Requirements	not applicable			
3.5 System Internal Data Requirements	not applicable			
3.6 Adaptation Requirements				
3.6.1 Avionics Compatibility			✓	
3.7 Safety Requirements				
3.7.1 Explosive Atmosphere			✓	
3.8 Security and Privacy Requirements	not applicable			

Paragraph / Title	Demo	Test	Analysis	Insp
3.9 System Environment Requirements				
3.9.1 Storage Temperature			✓	
3.9.2 Operating Temperature		✓		
3.9.3 Pressure Altitude			✓	
3.9.4 Temperature/Altitude		✓		
3.9.5 Relative Humidity			✓	
3.9.6 Vibration		✓		
3.9.7 Shock				
3.9.7.1 Crash Worthiness		✓		
3.9.7.2 Operational		✓		
3.9.8 Electromagnetic Compatibility Limits		✓		
3.9.9 Sand and Dust			✓	
3.9.10 Fungus			✓	
3.9.11 Salt Atmosphere			✓	
3.10 Computer Resource Requirements	not applicable			
3.11 System Quality Factors				
3.11.1 Reliability			✓	
3.11.2 Maintainability			✓	
3.12 Design and Construction Constraints				
3.12.1 Size				✓
3.12.2 Weight				✓
3.12.3 Mounting				✓
3.12.4 Connectors				✓
3.12.5 Color				✓
3.13 Personnel Related Requirements				
3.13.1 Connectors				✓
3.13.2 Power	✓			
3.14 Training Related Requirements				
3.14.1 Help Screens	✓			
3.15 Logistics Related Requirements	not applicable			
3.16 Other Requirements				
3.16.1 Technical Manuals				✓
3.17 Packaging Requirements			✓	
3.18 Precedence and Criticality of Requirements	not applicable			

5 Notes

5.1 Terms, Acronyms and Abbreviations

1553	Mil-Std-1553
ANSI	American National Standards Institute
avionics	science and technology of electronic systems and devices for aeronautics and astronautics

BC	1553 Bus Controller; directs data transfers on the 1553 bus
data system	One of several terms that refer to an independent system installed for collecting, transmitting, and recording test data
DI-FC	Project unique identifier – Fibre Channel avionics system data element
DI-PWR	Project unique identifier – Power data element
DI-SPD	Project unique identifier – System programming data element
DO-FAD	Project unique identifier – Formatted avionics data element
DoD	Department of Defense
CAIS	Common Airborne Instrumentation System; The current DoD standard instrumentation bus
COTS	Commercial Off The Shelf
EMI	Electromagnetic interference
FC	Fibre Channel
FC-AEP	Document; Fibre Channel Avionics Environment Profile
FC-FS	Document; Fibre Channel Framing and Signaling
FC-PH	Document; Fibre Channel Physical and Signaling
FC-PH-2	Document; Fibre Channel Physical and Signaling 2
FC-PH-3	Document; Fibre Channel Physical and Signaling 3
FC-PI	Document; Fibre Channel Physical Interfaces
FC-VI	Document; Fibre Channel Virtual Interface Architecture Mapping
Fibre Channel	An ANSI standard that provides a general transport vehicle for Upper Level Protocols (ULPs) such as Intelligent Peripheral Interface (IPI) and Small Computer System Inter-face (SCSI) command sets, the High-Performance Parallel Interface (HIPPI) data framing, IP (Internet Protocol), IEEE 802.2, and others.
IP	Internet Protocol
instrumentation system	One of several terms that refer to an independent system installed for collecting, transmitting, and recording test data
IRIG	InterRange Instrumentation Group; this group is now known as the Range Commanders Council (RCC). The term is still found on documents produced by the RCC.
Mil-Std-1553	A common avionics bus used by the military
MTBF	Mean Time Between Failures
profile	A narrowing in scope of a broad standard to aid interoperability for a particular purpose
PUID	Project Unique Identifier
RCC	Range Commanders Council (aka IRIG)
RT	Remote Terminal on a 1553 bus. The RT is directed by the BC.
T&E	Test & Evaluation
telemetry system	One of several terms that refer to an independent system installed for collecting, transmitting, and recording test data
UDP	User Datagram Protocol; a transport layer protocol
XIF-DATA	Project unique identifier – T&E data system external interface
XIF-FC	Project unique identifier – Fibre Channel avionics system external interface
XIF-PWR	Project unique identifier – Power external interface

Appendix A: Mil-Std-704A Transient Characteristics

MIL-STD-704A

*Fault Conditions (1,4)
 Bus Switching (2,3)
 Normal Equipment Switching (5,6)*

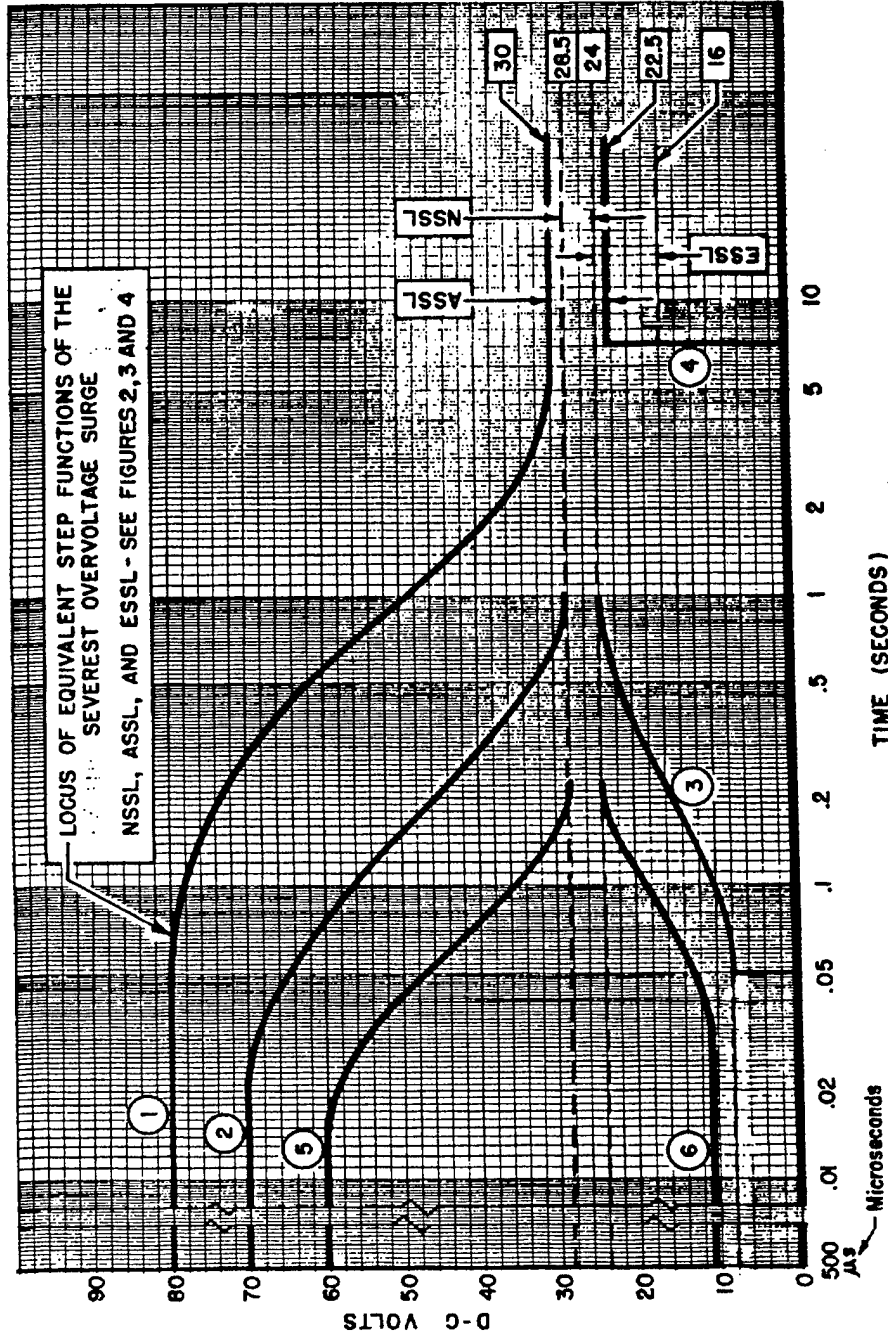

FIGURE 9. Transient surge dc voltage step function locus limits for category B equipment

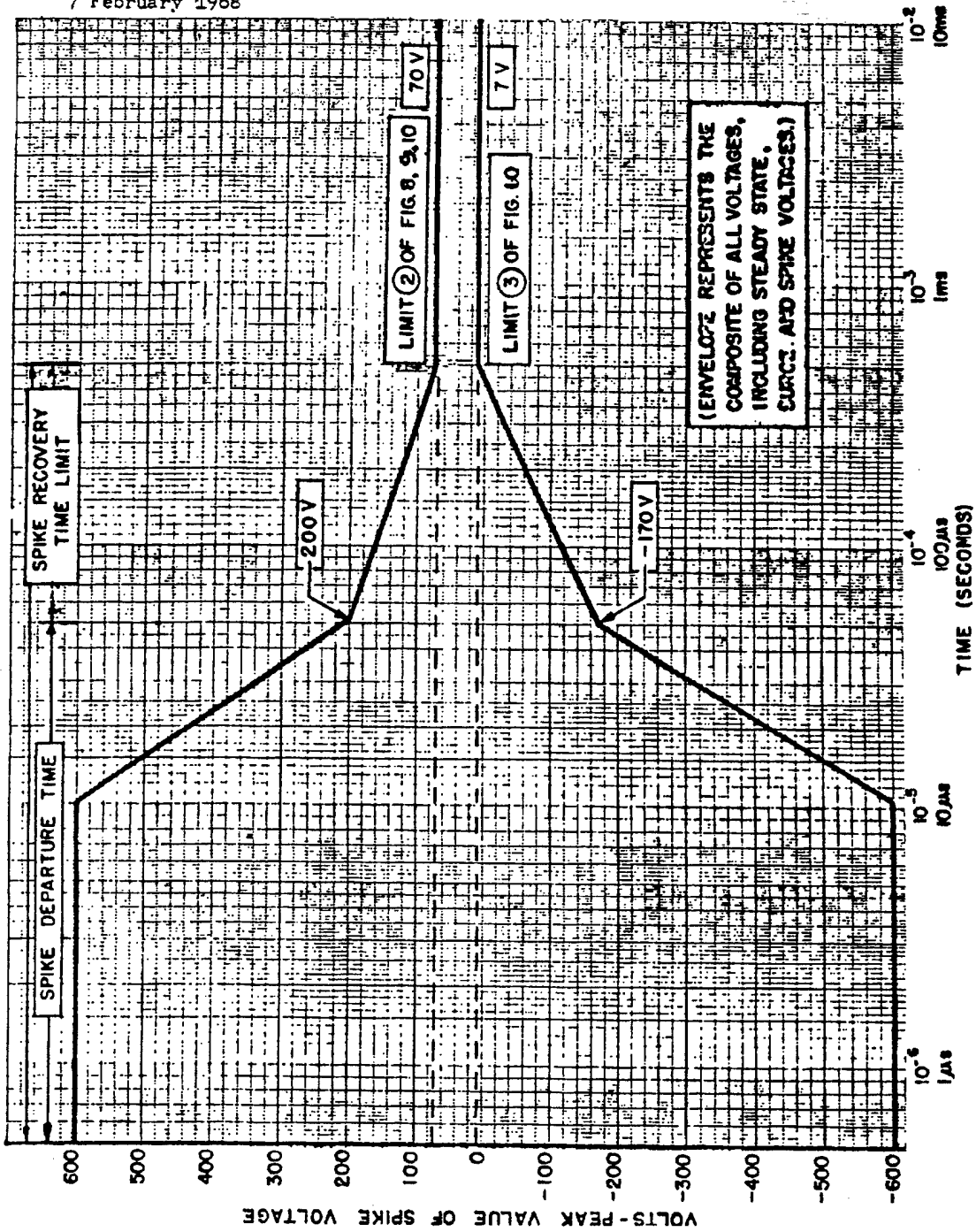

FIGURE 17. Envelope of spike voltages for dc equipment

Appendix K

Final Report Presentation

Fibre Channel Avionics Bus Monitor

Sid Jones

JHU System Engineering Project

Course No. 645.770

Ray Schulmeyer, Advisor

Background

- **Test & Evaluation data systems**
 - Acquire data during test or mission
 - From avionics computers, busses, systems
 - Installed transducers
- **Past 20 yrs, avionics used Mil-Std-1553**
 - Data systems monitor status of aircraft through avionics bus data
 - 1553 utilized a bus architecture
 - All data is available anywhere on the bus
- **New avionics busses require new approach**
 - High speed network bus architecture

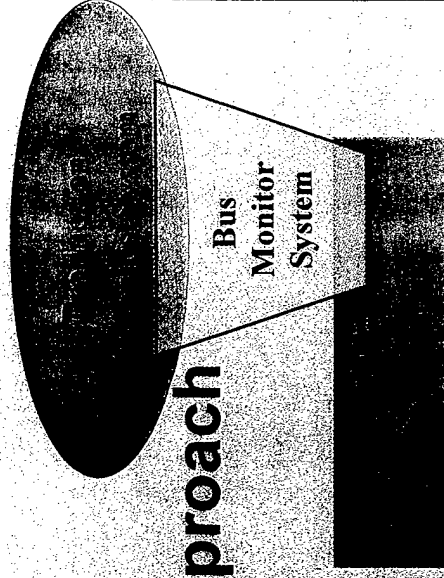

Overview

- **Subject**
 - Fibre Channel Avionics Bus Monitor
- **Objective**
 - Lay groundwork for development program by performing initial Systems Engineering Work
- **Scope**
 - Identify customer's needs and requirements for the product resulting in a systems requirements specification (A-Spec)

Approach

- Used Systems Engineering Approach

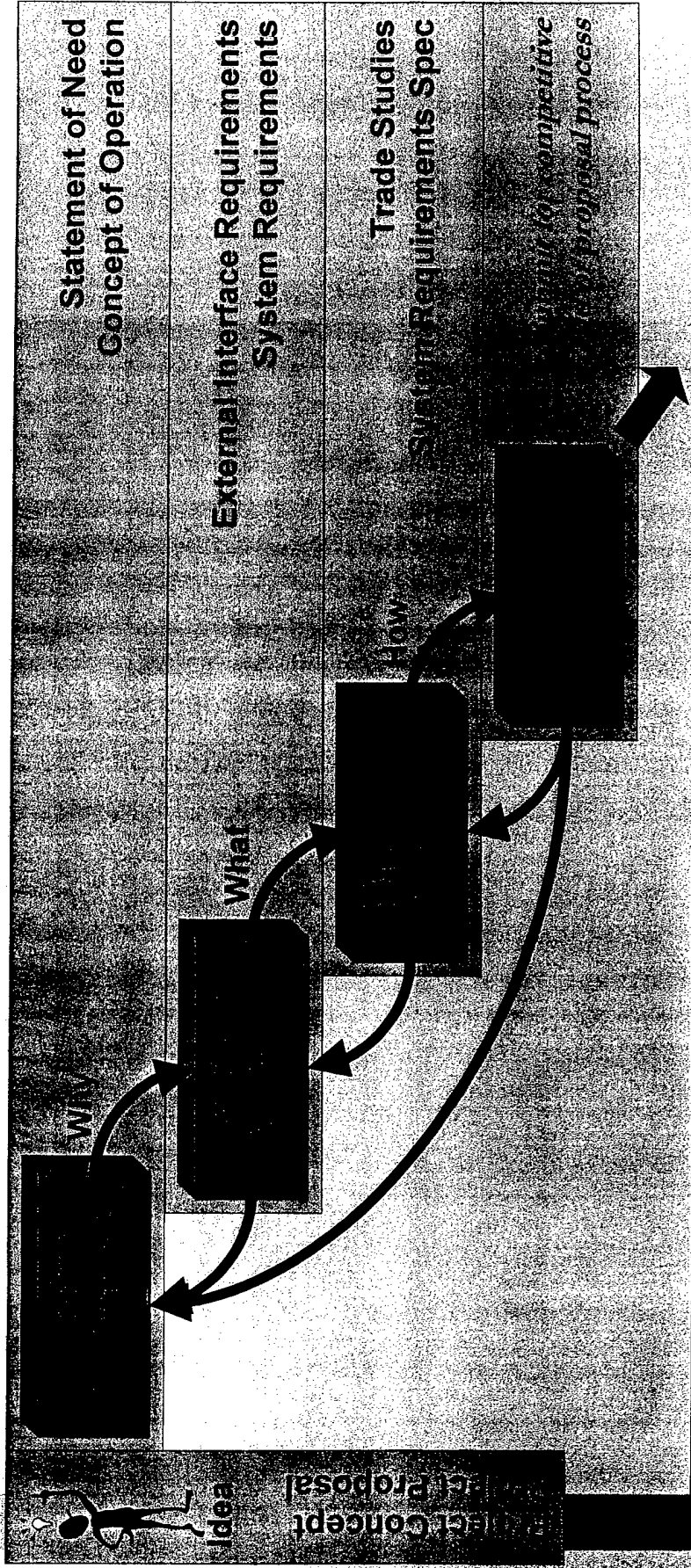

Products

Concept Development

Activity	Products	Appendix
Needs Analysis	Project Concept Project Proposal Statement of Need	A B C
Concept Exploration	Operational Concept Ext. Interface Requirements System Requirements Trade Studies Interim Report	D E F G/H I
Concept Definition	System Requirements Spec Final Report / Presentation	J K

Statement of Need

- **Basis**
 - **Acquisition Reform allows quick COTS integration**
 - e.g. Networked based avionics busses
 - **T&E organizations must be able to respond to instrumentation requirements**
 - **Minimal experience with networks and optical busses**
 - **Additional issues with bus speeds (1 GHz)**

Current Situation

- **Mil-Std-1553**
 - Bus Architecture
 - Single 'tap' has access to all bus data
 - Does not affect operation

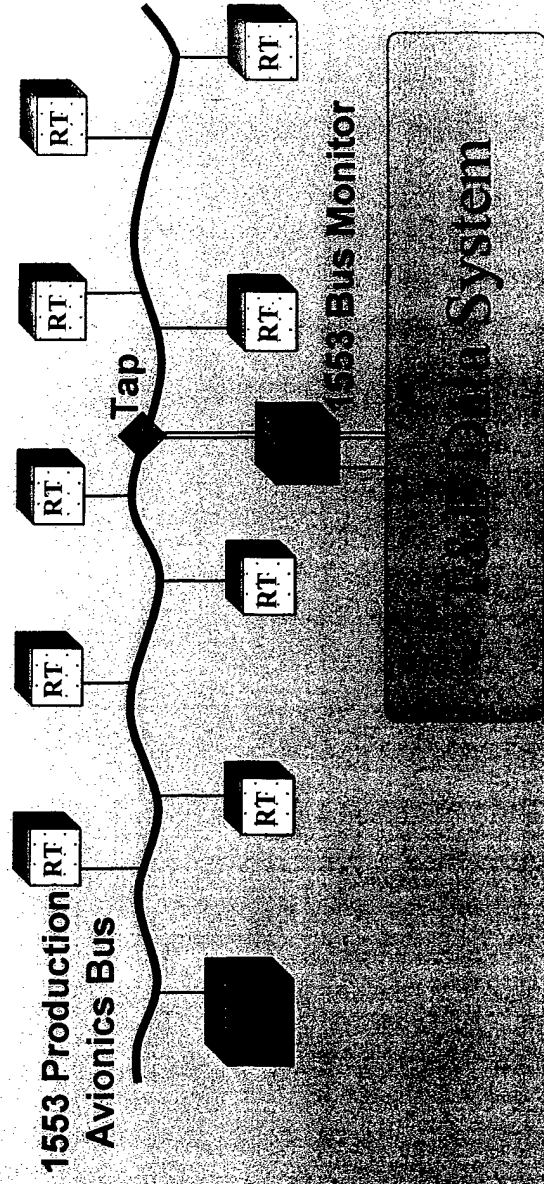

Networked Approach

- **Fibre Channel (FC)**
 - Nodes establish direct communication links through switch
 - No one location to monitor bus traffic

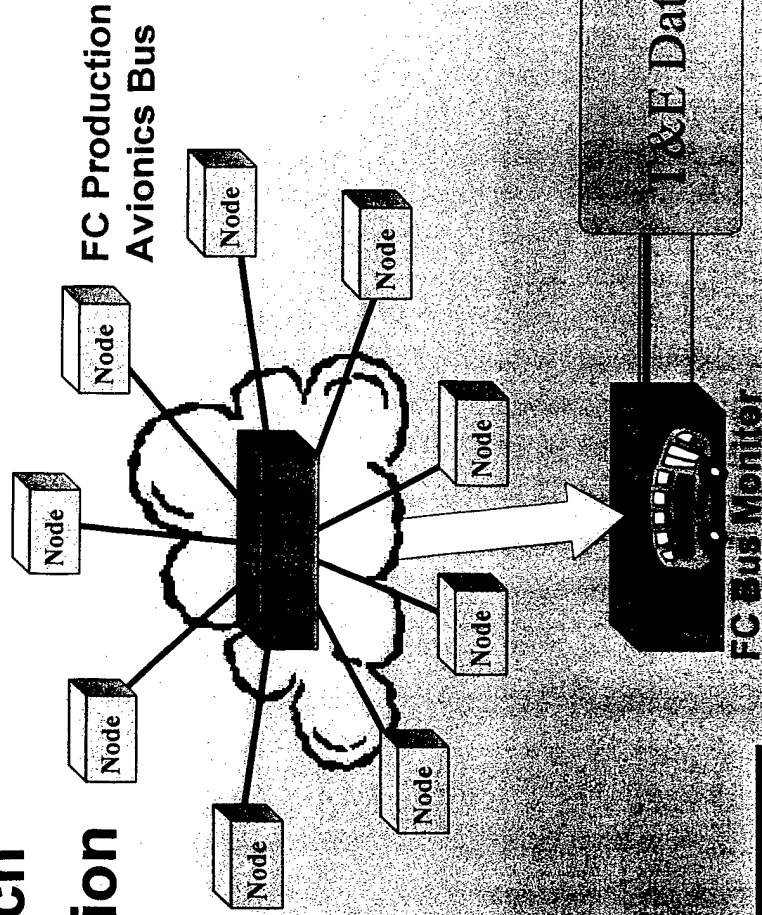

Cloud denotes uncertainty over how to monitor Fibre Channel

Deficiencies in Commercial Systems

- **Speed**
 - 1 GHz vs 1 MHz
 - Cable handling issues (noise, EMI)
 - Connector issues
- **Cabling**
 - **Fiber Optic vs Copper**
 - Cable handling issues (physical routing)
 - Connector issues (field manufacturability)
- **Layered Architecture (Networks)**
 - T&E community unfamiliar with concepts

Alternatives

- Ignore the bus
 - Acquire data using other means
- Use Mfrs method when airframe was built
 - Different processes for different airframes
- Military Programs
 - Wait for weapons platforms to identify an approach
- Vendors
 - COTS products may emerge with respect to previous two options

Constraints

- **'System Under Test' vs 'Truth Data'**
- **Airborne Uninhabited Fighter Environment**
- **Does not compromise integrity of avionics**
 - High speeds, Network protocols, and Fiber Optics compound this issue
- **Not many 'Network Aware' T&E personnel**
 - Focused on traditional systems
 - Don't understand network concepts

External Interfaces

Interface	PUID	Interfacing Entities	Characteristics
FC Avionics Bus	XIF-FC	Production Avionics Bus	Secondary, Input
T&E Data System Bus	XIF-DATA	COTS Data System Bus	Secondary, Bi-directional
T&E Data System Power	XIF-PWR	Data System Power Distribution	Secondary, Input

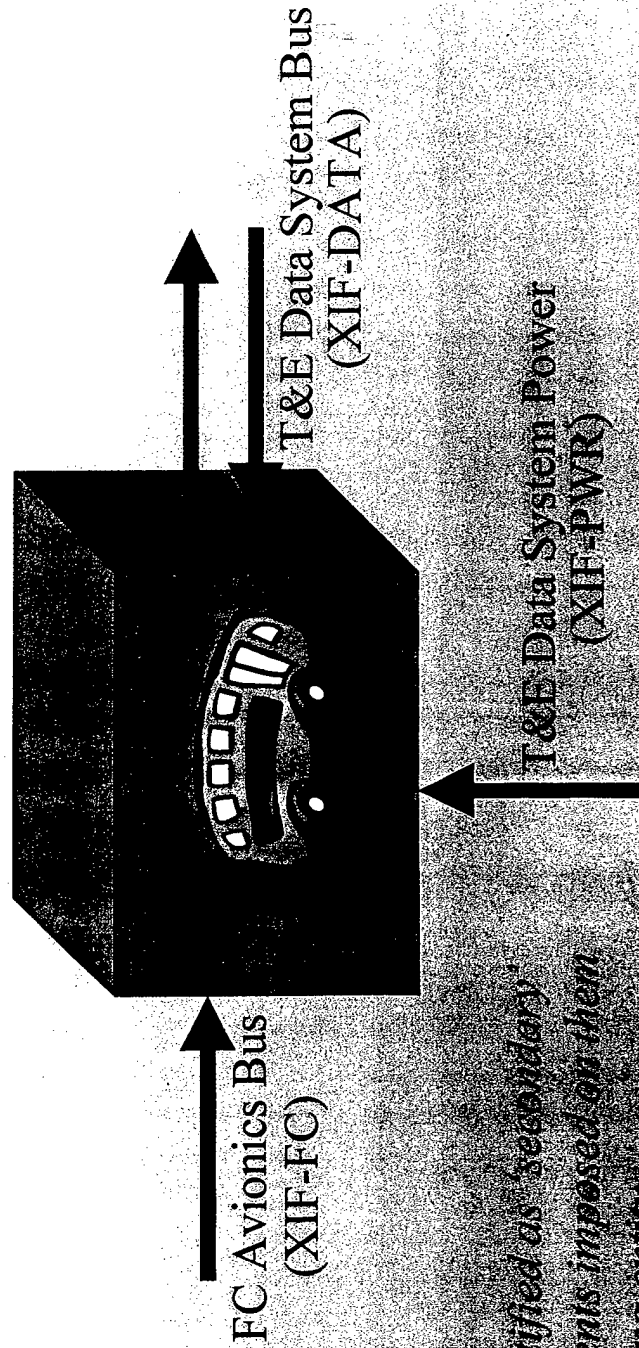

Interfaces identified as 'secondary' have requirements imposed on them by the interfacing entity.

Operational Concept

- High-speed network technology driving data systems towards similar busses
- Both 1553 and Fibre Channel bus monitors will coexist in data systems for the near term

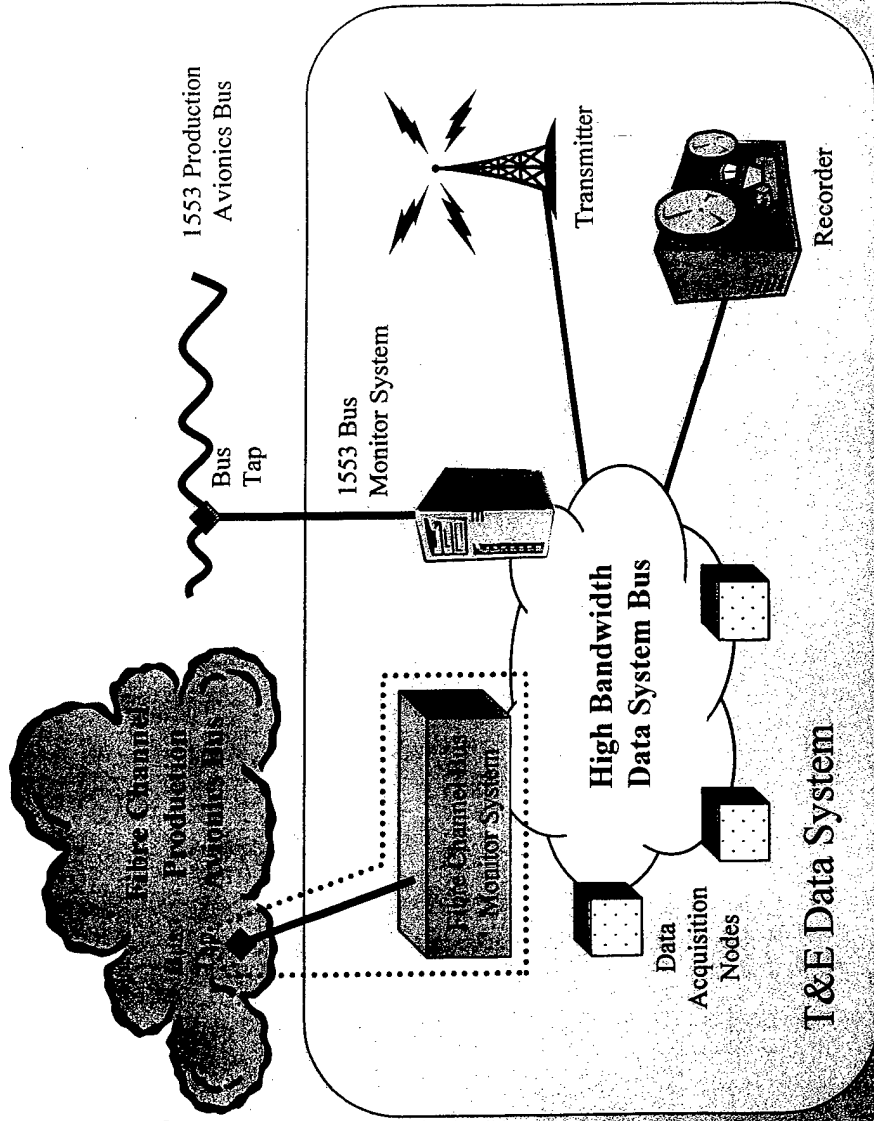

Trade Study

Bus Tap Method

- **ISSUE: Tapping into fiber optic switched fabric**
- **Alternatives**
 - Developer's Approach
 - Individual optical taps at each node
 - Replace switch with instrumentation switch
 - Levy requirements onto production switch

Trade Study

Bus Tap Method Results

Criteria	Weight	Initial	Final	Prod Switch
Affects production system	Y/N	N-3	N-3	Y-0
Timeliness	L/M/H	M-2	H-3	L-1
Independent from production system	L/M/H	H-3	H-3	L-1
Ease of subsequent flight clearance	L/M/H	L-1	H-3	H-3
Availability of required data	L/M/H	L-1	H-3	M-2
Ease of physical installation	L/M/H	L-1	L-1	H-3
Raw Score (18 max)		11	16	10
Weighted Score (3 max)		2.1	2.8	1.3

Trade Study

Bus Tap Method

- **Recommend:**
 - *Individual Optical Taps*
 - Scalable
 - Independent of platform, avionics hardware & software
 - Acquires all necessary data

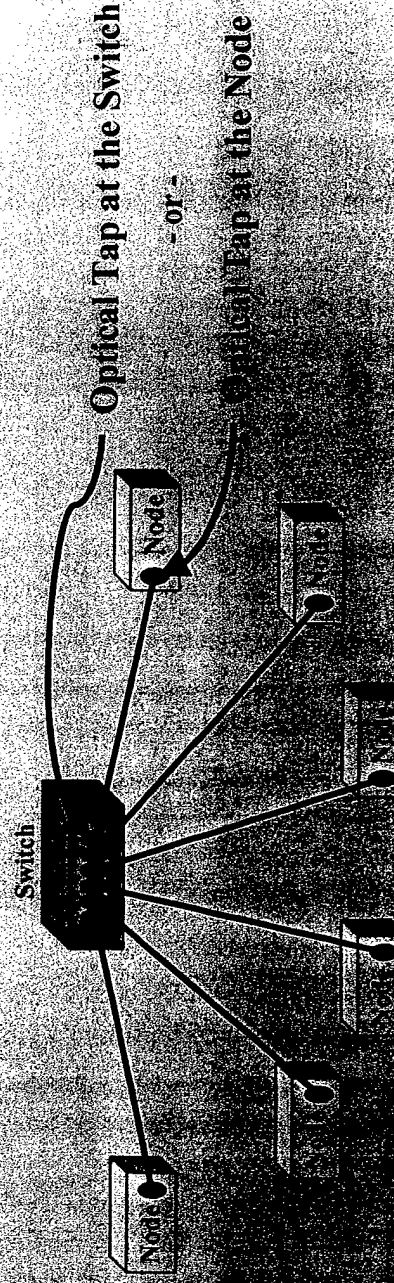

Trade Study

Product - Optic Bin Lap

<http://www.ofr.com/splitter/split1.html>

Fiber-Optic Splitters/Combiners

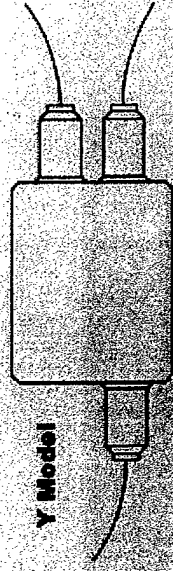
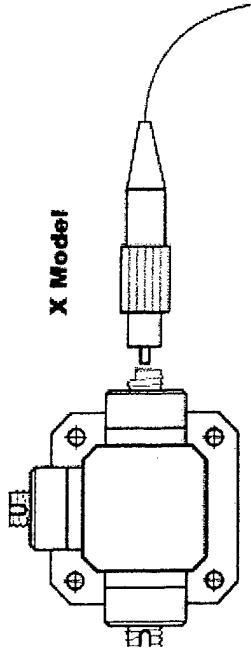
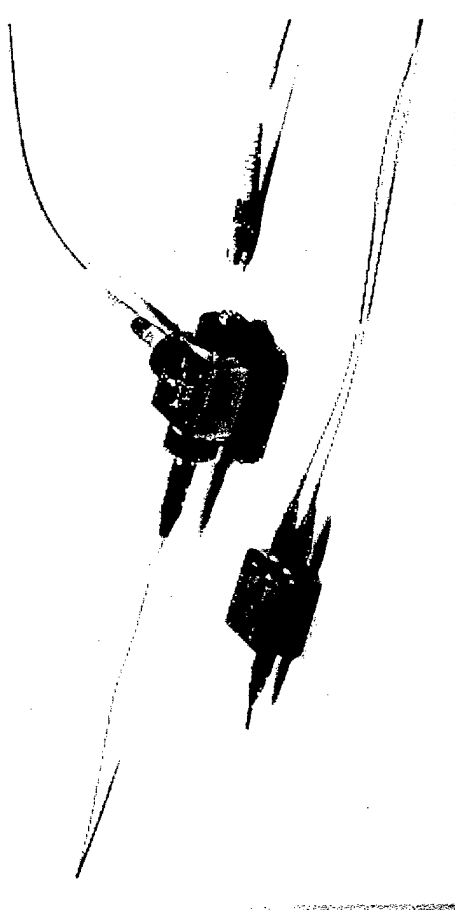

Trade Study

Development Technology

- **ISSUE: Functional and cost effective technology to use as basis of design**
- **Embedded Computer Alternatives**
 - **PC/104 & PC/104+**
 - **PCI Mezzanine Card (PMC)**
 - **Industry Pack (IP)**
 - **Custom Design**

Trade Study

Development Technology Results

Criterion	PCI	PMC	Custom
Backplane Bus Speed Raw Score	132 2.3	528 10.0	16 0.0
Technology Availability Raw Score	M 5	H 10	L 0
Environment / Ruggedability Raw Score	T-M 6	F-M 10	A-M 2
Supportability / User Base Raw Score	M 5	H 10	M 5
Size Raw Score	in2 13.68 4.2	17.7 1.5	7.0 8.7
	22.5	41.5	15.7
Total Raw Score			21.5
Weighted Score (out of 10)		9.6	

Note 1: It is assumed a custom design would utilize a 32 bit PCI bus or equivalent

Note 2: Used common miniature data acquisition card size of 2.5x2.5.

Trade Study

Development Technology

- **Recommend:**
 - *PMC Technology*
 - 528 MHz backplane bus speed
 - Ruggedized FC products available NOW
 - Large industry user group
 - IEEE 1386.1

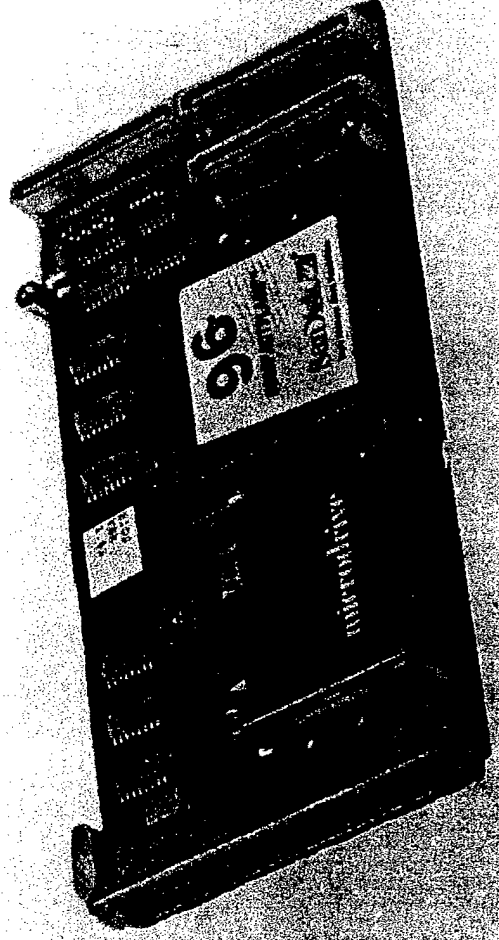

System Requirements Specification

Specifies the requirements for the system and the methods to be used to ensure that each requirement has been met

- **Scope**
 - Provides general overview and purpose of the document
- **Referenced Documents**
 - Identifies program documents and those referenced in specification
- **Requirements**
 - Documents the requirements for the FC Avionics Bus Monitor
- **Qualification Provisions**
 - Details the qualification methods necessary for fulfilling the specified requirements

System Requirements Validation

- Validated through many processes
 - Discussions
 - DoD - NAWCAD, AFFDC, AFFTC, APG
 - DoD Standards Groups - Range Commanders Council, Telemetry Standards Coordinating Committee
 - Industry Standards Groups - Fibre Channel Avionics Environment Group
 - Industry Vendors - Teletronics, Calculex, Apogee, L-3 Communications, Veridian, et al.
 - Symposiums
 - International Telemetering Conference (ITC)
 - International T&E Association (ITEA)

Risk Assessment

- 7 Risks identified
 - 2 Items closed as of Interim Report
 - 3 Items closed as of Final Report

2 Items remain open

• Network aspect of Avionics

Avionics implementations using networks are still in the development phase

Low/Med

• Unknown that some of the

elements are not complete

Low/Med

Project Summary

Tasks/Products	Estimated Hours	Actual Hours
Write Concept Proposal	10	11
Needs analysis	15	18
Requirements Analysis	15	17
Concept of Operations	39	39
Identify external interfaces	16	23
Identify system requirements	10	16
Trade Studies		
Bus tapping method	29	23
Development Technology	25	27
Interim Report	12	6
System Specification	26	23
Final Report		13
Final Report		12
Total Hours	222	228

Conclusions

- **Output Data Format**
 - Project work defining output message structure currently ongoing
 - Will require close coordination
- **Fiber Optic Bus Tap**
 - Individual taps was the preferred solution
 - Until research for trade study, didn't know optical taps existed

Conclusions

- **Actual Tap Method**
 - Expect to use a variety of tap methods
 - Methods based on specific project requirements and maturity of COTS approaches
 - Expect methods to evolve as Avionics mature
- **Flight Clearance Process**
 - Originally thought this would be a major issue
 - Discovered, my organization is recognized as the 'experts'
 - We make the technical decision to fly

What's Next

- **Small Business Innovative Research (SBIR)**
 - Write SBIR proposal
 - Bundle SysEngProj products into informational package
- **Vendors**
 - Provide bundled products to commercial market

Questions & Answers