

REPORT DOCUMENTATION PAGE			Form Approved OMB No. 0704-0188	
Public reporting burden for this collection of information is estimated to average 1 hour per response, including the time for reviewing instructions, searching existing data sources, gathering and maintaining the data needed, and completing and reviewing this collection of information. Send comments regarding this burden estimate or any other aspect of this collection of information, including suggestions for reducing this burden, to Department of Defense, Washington Headquarters Services, Directorate for Information Operations and Reports (0704-0188), 1215 Jefferson Davis Highway, Suite 1204, Arlington, VA 22202-4302. Respondents should be aware that notwithstanding any other provision of law, no person shall be subject to any penalty for failing to comply with a collection of information if it does not display a currently valid OMB control number. PLEASE DO NOT RETURN YOUR FORM TO THE ABOVE ADDRESS.				
1. REPORT DATE		2. REPORT TYPE Professional Paper	3. DATES COVERED	
4. TITLE AND SUBTITLE Foil Face Seal Development		5a. CONTRACT NUMBER		
		5b. GRANT NUMBER		
		5c. PROGRAM ELEMENT NUMBER		
6. AUTHOR(S) John Munson, Darrell Grant, Giri Agrawal		5d. PROJECT NUMBER		
		5e. TASK NUMBER		
		5f. WORK UNIT NUMBER		
7. PERFORMING ORGANIZATION NAME(S) AND ADDRESS(ES) Naval Air Warfare Center Aircraft Division 22347 Cedar Point Road, Unit #6 Patuxent River, Maryland 20670-1161		8. PERFORMING ORGANIZATION REPORT NUMBER		
9. SPONSORING/MONITORING AGENCY NAME(S) AND ADDRESS(ES)		10. SPONSOR/MONITOR'S ACRONYM(S)		
		11. SPONSOR/MONITOR'S REPORT NUMBER(S)		
12. DISTRIBUTION/AVAILABILITY STATEMENT Approved for public release; distribution is unlimited.				
13. SUPPLEMENTARY NOTES				
14. ABSTRACT This paper describes the development to date of a novel combination of a foil gas thrust bearing and conventional face seal secondary to produce a hybrid design. The thrust-bearing portion has demonstrated an ability to handle sea face distortion far in excess of any other gas film riding seal. Some seal leakage has been sacrificed to accomplish this. Testing of the complete seal package including the secondary seal remains to be done. This will allow determination of actual seal leakage rates. The hybrid concept has some flexibility to tailor leakage rates and distortion capability. It is expected that an optimized configuration will be tested in the AADC/GE Phase III JTDE engine.				
15. SUBJECT TERMS				
16. SECURITY CLASSIFICATION OF:		17. LIMITATION OF ABSTRACT	18. NUMBER OF PAGES 10	19a. NAME OF RESPONSIBLE PERSON Darrell Grant
a. REPORT	b. ABSTRACT			c. THIS PAGE

Standard Form 298 (Rev. 8-98)
Prescribed by ANSI Std. Z39-18

20010716 025

CLEARED FOR
OPEN PUBLICATION

29 Jun 01

PUBLIC AFFAIRS OFFICE
NAVAL AIR SYSTEMS COMMAND

H. Howard

AIAA 2001-3483

Foil Face Seal Development

J. Munson

Rolls Royce – Indianapolis

D. Grant

Naval Air Warfare Center – Aircraft Division Patuxent River,
MD

G. Agrawal

R&D Dynamics – Bloomfield, CT

**37th AIAA/ASME/SAE/ASEE Joint Propulsion
Conference**

July 8-11, 2001
Salt Lake City, UT

Abstract

Gas film riding seals have found wide acceptance in pipeline and process industry turbomachinery. The seals have not found any application in the gas turbine prime movers, however. This is despite the demonstrated connection between better seals and improved gas turbine engine performance.

The gas turbine operating environment requires that the seals operate at relative surface velocities and gas temperatures that in general exceed those of all other applications. In and of themselves these conditions are solvable using existing technologies and materials. Unfortunately, a flight worthy gas turbine places additional restrictions on allowable size, weight and to some extent cost of the seal. In addition, the structural portions of the engine are also lightweight. This latter characteristic in particular means that the seal cannot be completely isolated from the distortion of the surrounding structure. It is this last problem in combination with the other requirements which has more than anything else prevented the application of film riding seals in gas turbine engines.

The paper describes the development to date of a novel combination of a foil gas thrust bearing and conventional face seal secondary to produce a hybrid design. The thrust-bearing portion has demonstrated an ability to handle seal face distortion far in excess of any other gas film riding seal. Some seal leakage has been sacrificed to accomplish this.

Testing of the complete seal package including the secondary seal remains to be done. This will allow determination of actual seal leakage rates. The hybrid concept has some flexibility to tailor leakage rates and distortion capability. It is expected that an optimized configuration will be tested in the AADC/GE Phase III JTDE engine.

Introduction

All gas turbine engines bleed off some of the compressed air into so called secondary flow circuits. This air is withdrawn from the primary gas path. It is a parasitic loss to the engine thermodynamic cycle causing degradation in efficiency. This air does provide a necessary function in that it is mostly used to provide cooling for various components within the engine.

These secondary airflows are metered via air-to-air seals. Relative velocities are high, typically 500 ft/sec and up. Temperatures in the turbine section of the engine are also high 800°F and above are typical. Since the beginning of the gas turbine, labyrinth seals have traditionally been used to seal these locations. Unfortunately, large thermal gradients, particularly during start up and shut down, result in considerable radial and axial excursions between the rotating and stationary parts of the seals. This makes it difficult to minimize operating clearances and so leakage through these seals is usually greater than it could be if a better seal were available.

It has been known for some time that if better seals were available engine performance could be substantially improved. Munson, et.al.¹, for example, shows that the use of just three advanced seals could reduce direct operating cost of a modern regional jet by almost 1%. This substantial benefit was the result of reduced fuel consumption and reductions in chargeable maintenance caused by being able to produce the same power output at a lower turbine inlet temperature. In order to achieve these benefits it was necessary to place advanced mechanical seals very near to the blade / vane gaps in the high pressure turbine. Munson goes on to indicate that these locations are amongst the most difficult to seal because of the speed, temperatures, large excursions, and the inability to keep parts flat due to the large thermal gradients which characterize these locations. Munson provides a table of expected deflections and distortions at the three advanced seal locations along with speeds, temperatures, and differential pressure range.

It is difficult to think of any other single improvement that could be made that could provide a similar benefit at similar cost. It is this large benefit for cost that has sparked the search for better gas turbine seals. This process has produced abradable coatings for labyrinth seal stators and variations of labyrinth tooth geometry. More recently, seal researchers have developed brush seals^{2,3}. These seals attempt to provide essentially a labyrinth seal tooth with some compliance. The compliance allows the seals to track radial clearance excursions with only minimal wear of the seal. Leakage thus remains lower for a longer time relative to a labyrinth seal operating at the same location.

Over the past thirty years, several researchers tried to adapt mechanical face seals for use as advanced

secondary air seals. Probably the earliest large effort in this direction is that described by Dobeck⁴. The focus of this effort was to modify Pratt & Whitney's oil cooled face seals, already in use in engine bearing sumps, to a configuration that did not require oil cooling. This program introduced the film riding or gas lubricated face seal. Later efforts followed for example, Lynwander^{5,6}, O'Brien⁷ and Munson & Pecht⁸. The work describes efforts to increase the stiffness of the gas films and increase demonstrated operating conditions. New lift features such as spiral grooves, etc. are described. New materials, such as silicon carbide are introduced to overcome temperature limitations of carbon graphite. The latter paper also describes efforts made to overcome problems with seal face distortion that has historically denied application of this technology to gas turbine engines.

More recently, Gardner⁹ describes a double spiral groove hydrostatic type seal. If one or both of the seal faces should experience a conical distortion in operation, these spiral grooves would tend to produce a moment on the seal faces in the opposite direction. To take advantage of this righting moment the stationary or primary seal ring has deliberately been made thin and flexible, the remainder of the seal follows typical face seal design practice. The intent of this design is to allow the hydrostatic seal to self-compensate for expected in-service conical distortion and thus potentially extend its useful operational envelope. The concept is currently under development.

The devices described in the aforementioned references describe hydrodynamic face seal designs. These rely primarily on the relative rotation of the seal faces to generate the lift force that separates the seal faces. The conclusion from review of this work

is that the thin gas films that characterize this type of seal allow almost no distortion of the seal faces. In applications where this can be guaranteed successful applications result. For example, hydrodynamic designs have come to dominate the gas pipeline and process industry applications where distortion can be controlled, Hesje and Peterson.¹⁰ Where this cannot be guaranteed, such as inside a gas turbine engine, success has proved elusive.

Another potential choice is a hydrostatic seal. These only need an applied differential pressure.

Hydrostatic designs work best with thin gas films, on the order of .0001". Hydrostatic seals on the other hand, can operate with 10 times this film thickness. This increases the acceptable amount of distortion that the seal can tolerate without contact between the relatively rotating seal faces.

Tseng^{11,12,13}, describes the development of a large hydrostatic face seal for use in an aircraft gas turbine engine. The thick gas film allows the seal to cope with the expected distortion levels of the seal faces when operated in the engine. Leakage through this type of seal is much higher than what would be expected from an equivalent diameter hydrodynamic face seal. However, it is pointed out that leakage is much lower than what can be obtained from any other potential seal type, and is still expected to provide over 1% savings in engine specific fuel consumption (SFC). During engine start and shutdown transients insufficient differential pressure is available to separate the seal faces. To overcome this an "aspirating" labyrinth seal tooth has been applied in parallel with the seal. This allows the seal to remain "open" (non-contacting) until sufficient differential pressure is available to support the seal faces. This seal has undergone considerable rig development testing. It has met all of its test

objectives. It is to be ground tested in a gas turbine engine in the near future.

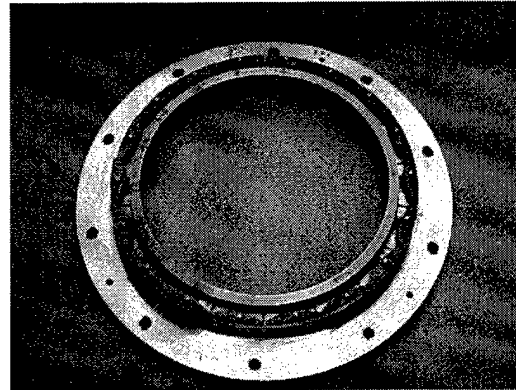
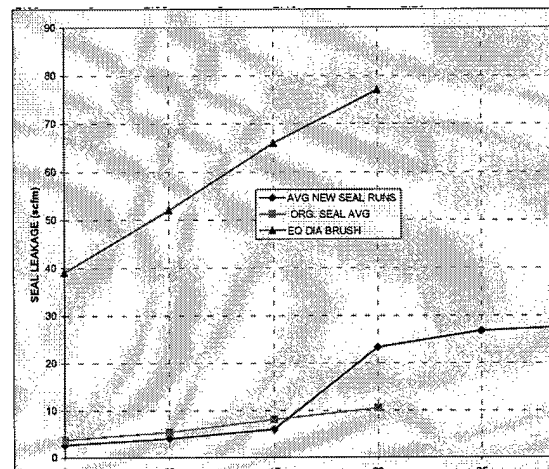

Figure 1: Segmented circumferential seal ring allows tracking of non-circular seal runner.

Although promising for some gas turbine applications, these seals cannot be utilized at the high value turbine rim seal locations¹. Because of the very low differential pressures that prevail at these locations, these seals must be hydrodynamic. There is one potential means of creating a hydrodynamic seal that can operate at these locations. This can be accomplished by making the seal ring more compliant than the gas film that separates the sealing faces. Our original adaptation of this concept was to create a segmented circumferential seal. This seal is shown in Figure 1. The seal ring has been divided into 18 independent segments. The segments are arranged to spring out radially against the inside diameter of the rotating seal runner. The seal runner has not been shown in the figure. The particular version of the seal shown in the figure used Raleigh



step pads to generate lift. A subsequent version had no fine geometry, but instead relied on the individual segments to act like tilt pad bearings.

Figure 2 : Measured leakage compared very favorably with an equivalent diameter brush seal.

Both versions of the seal were rig tested. Measured seal leakage was higher than what would be expected from an equivalent diameter conventional circumferential seal. As Figure 2 shows, however, the observed leakage compared very favorably with a brush seal.

Advantages claimed for this concept include:

- The ability of the seal to track circumferential out of roundness
- The ability to easily scale the design by simply adding or subtracting segments
- No need for fine geometry to generate lift using the tilt pad concept
- It was felt that the seal would be robust since there would be no fine geometry features that could wear or become clogged in service.

Despite these perceived advantages, development of this seal concept was abandoned. The major reason is that the seal was intended for use at an engine turbine rim location. Figure 3 shows how the seal might have been incorporated into an engine turbine rim location. It was realized that operation at the high temperatures typical of these locations would require that the seal segments be manufactured from probably a ceramic material. Unfortunately, the large mismatch in thermal expansion coefficients between potential ceramic materials and the surrounding superalloy materials would create a large excursion in curvature mismatch between the segment and the seal runner. Analysis confirmed that this was, in fact, unmanageable. We noticed that this fatal flaw could be removed if the concept was recast as a face seal.

Approach / Present work

The segmented seal ring concept translates into a face seal in the form of a multiplicity of sector shaped tiles. This seemed more complex than desirable. The foil thrust bearing accomplishes the same idea with far less structure, and mechanical complication. These devices have undergone extensive development. Perusal of the literature will reveal many successful production applications of these bearings, for example Agrawal¹⁴. The concept for the new face seal then is to utilize a foil thrust bearing for the primary seal face. This is attached to a more conventional face seal axially moveable structure and secondary seal. The design intent is that the foil-bearing portion of the seal will accommodate out-of-flatness distortions of the seal mating ring. The secondary seal will allow the foil bearing to accommodate the much larger axial excursions as the rotating and stationary portions of the engine undergo operating thermal transients. Again, leakage has been sacrificed to allow the seal to be flexible enough to operate in its intended location.

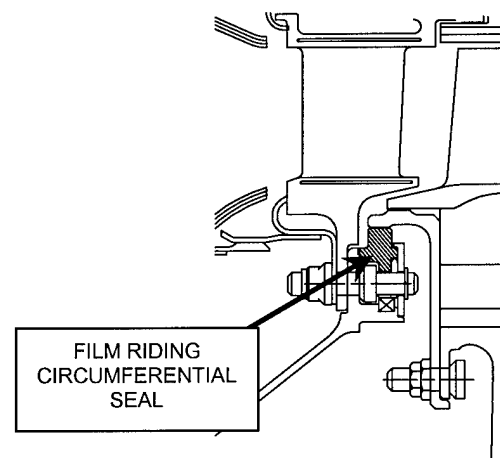

Figure 3 : The circumferential film riding seal packaged easily into a gas turbine engine turbine. Allison conducted an extensive literature survey of foil bearing capability prior to committing to the

hybrid seal concept. Approximately 375 citations were reviewed covering the period from 1990 to the present. Although no references to foil face seals were reported, the literature survey revealed the existence of an extensive foil journal and thrust air bearing design, test, and manufacturing base. The great advantage of the foil design over the fixed geometry designs is the conforming nature of the foils. These have been shown to accommodate thermal and dynamic shaft and housing deflections. When used in journal bearing applications they have also demonstrated the ability to prevent half-speed whirl indicating that they are capable of providing stable operation.

The first task was to develop the foil-bearing portion of the seal such that it would be capable of accommodating the anticipated levels of distortion. A preliminary engine design study produced anticipated operating conditions for the seal at selected turbine rim locations. These are presented in Table I.

Table I : Anticipated Turbine Rim Operating Conditions

	<u>1V-1B</u>	<u>1B-2V</u>	<u>2V-2B</u>
Temp. °F (Max. Source)	1148	1108	1108
ΔP Max (psid)	25.9	28.8	55.8
ΔP Min (psid)	0.02	0.57	6.28
Conical Distortion (in)	.003	.004	.009
Circ. Out of Flat. (in)	.003	.004	.009
Rel. Radial Excursion (in)	0.04 - 0.09	0.08 - 0.13	0.02 - 0.08
Rel. Axial Excursion (in)	0.04 - +0.2	-0.03 - +0.13	-0.04 - +0.19
Maximum Speed (ft/sec)	1150	1050	1050

Three potential locations are presented in the table.

Of note are the conical and out-of-flat distortions, and the very low differential pressures that occur at certain points in the operating cycle. Speed is high as

expected along with operating temperatures.

Temperature is within the capability of existing materials. The first location listed in the table is between the turbine inlet vane and the first stage turbine rotor. This is similar to the location shown in figure 3. The second two locations seal a vane located between two turbine stages. Figure 4 is a sketch showing how this might look. This is a very common turbine sealing application.

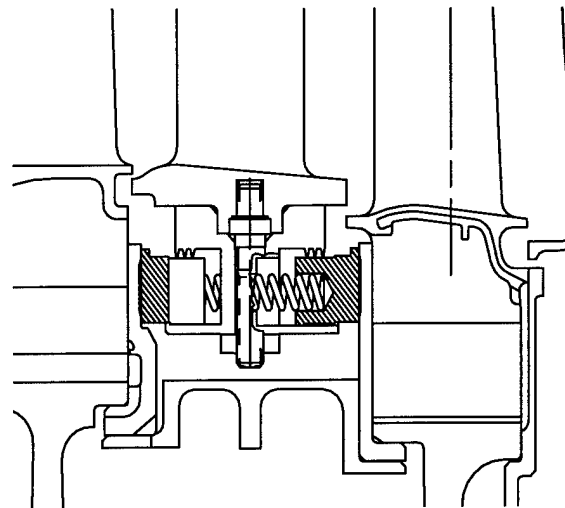

Figure 4: Sketch showing how a foil face seal might be applied at a typical turbine interstage seal location.

To date, there have been several iterations of the foil-bearing portion of the seal. The goal was to optimize this portion of the seal first. There are several inputs to this process including:

- High film stiffness and load capacity
- Maximum flexibility of the foil elements
- Ease of manufacturing
- Designs that would favor lower leakage

Hardware for two initial designs was fabricated.

These prototype assemblies are approximately 4.5”

in diameter. Sub-scale hardware was chosen to reduce cost and allow the pieces to be tested in existing equipment. Figure 5 shows a paper mock-up for one of the designs. This design consists of a number of foil segments. Beneath these segments is another set of segmented foils that serve to preload the top foils against the rotating mating surface. The entire assembly is stacked on a backing plate and anti-rotated.

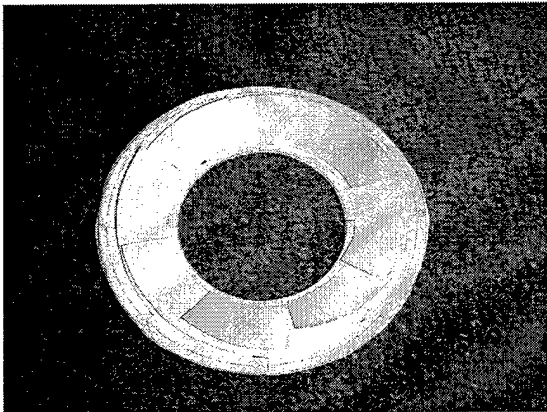

Figure 5: Paper mock-up for proposed foil face seal design. The seal ring is composed of many independently acting segments

The test rig is completely air operated. It is driven by a small air-turbine. An air-operated piston provides axial load. Air bearings locate the shaft. These rigs were used to characterize the seals. Various levels of thrust load were applied and the seals were spun up to surface speeds equivalent to those shown in Table I and then allowed to coast down. Torque was measured continuously during these tests. Speed where lift-off occurs is thus documented. A family of curves is generated by repeating the same experiment with increased thrust load. This data allows film stiffness and load capacity of the different design to be compared. High film stiffness and load capacity

are preferred, all things being equal. The bearings that have been tested will all support a modest 10 psi bearing load. This is sufficient for the intended application since in this case the bearing is being asked to only support itself, not an external thrust load applied through a shaft.

Conical Distortion Testing

The face seal top plate was tested repeatedly for conical distortion of 0.52° and 0.32° . Two distortion plates were manufactured to simulate the expected distortion between thrust runner and the face seal. The distortion was created in the face seal top plate by installing the seal on top of the distortion plate. The distortion plate caused the face seal top plate to take same shape as the shape of the distortion plate during testing. The face seal top plate results were compared with R&D Dynamics foil thrust bearing results for performance and load capacity. The outcomes of this analysis indicate the seal top plate has a measured load capacity higher than the 60.0-pound maximum test load that was applied. Maximum load capacity will be established by test later in the program. The data obtained from 0.52° and 0.32° conical distortion tests are compared with each other in Table II. There are very small differences between the torque values for each applied load.

Table II: Comparison of Measured Torque Values at Conical distortions of 0.52° and 0.32°

Axial Load (lbs.)	Torque at 0.52° (in-lbs)	Torque at 0.32° (in-lbs)
10	0.35	0.31
20	0.47	0.40
30	0.64	0.61
40	0.84	0.75

Testing was done using the standard flat backing plate before the conical tests and then after the testing was completed. There was no significant difference in torque results before versus after.

Circumferential Distortion Testing

Several more backing plates were manufactured with circumferential out of flatness. Testing was conducted with plates that had one wavelength per circumference and a flatness of 0.009" and 0.004", 2,3,4 waves per circumference and 0.009" out-of-flatness. In all cases, the seal top plate was installed on top of the out of flatness plate. It caused the seal top plate to take on the shape of the supporting plate.

The circumferential out of flatness test results for the one wavelength per circumference testing are compared with the standard flat test in Table 3. The torque readings for the circumferentially out of flat tests are lower in both cases than for the standard flat plates. This can be explained if the assumption is made that, more of the axial load is being carried by the peak areas of the out of flatness. The average film thickness therefore is increased and since torque is proportional to the third power of film thickness, one would expect a decrease in torque. In general, reduced torque is good. There is a limit, as the minimum film thickness at the peaks of the waves decreases at the same time. Eventually, asperities will contact and wear will result. Another disadvantage is that the leakage will also increase since this is also proportional to film thickness.

The current air-bearing portion of the seal successfully tracked all of the wavy plates. No contact was observed Torque seemed to be slightly less as the number of waves increased, but this was a minor effect. These results confirm that by making at least one face of the seal flexible it can be made to

track very large distortions of the rotating mating ring.

Table III: Torque values at Normal and 0.009 inches and 0.004 inches Out of flatness

Axial Load (Lbs.)	Torque Cir. Out-of-Flatness 0.009" (in-lbs.)	Torque Cir. Out-of-Flatness 0.004" (in-lbs.)	Torque from Normal Test (in-lbs.)
10	0.256	0.218	0.320
20	0.1755	0.148	0.432
30	0.277	0.270	0.510
40	0.351	0.351	0.620
50	0.410	0.425	0.680

This portion of the development focused on the ability of the foil face portion of the seal to accommodate relatively large distortions as compared to existing film riding face seal technology. The results are extremely encouraging, as the distortion levels that have been demonstrated are more than an two orders of magnitude greater than what conventional face seals can tolerate. The remaining task is to package the foil face portion of the seal with a secondary seal. The complete assembly will then be subjected to the same test program. The test rig will be modified, however so that a differential pressure can be maintained across the seal. This will allow the leakage performance to be characterized versus operating condition

The seal should have several advantages, including:

- Segmentation of the primary ring allows the seal to be easily sized for other applications since pads can be added or subtracted as needed without influencing the performance of any particular segment
- The seal is relatively lightweight since most of it is constructed of sheet metal.
- It is relatively inexpensive since it is constructed primarily of readily available sheet metal. It also does not require the manufacture of fine groove

features to generate lift since the pads distort to create lift on their own.

- It should be relatively robust since there are no fine features to clog in service.
- There are no limitations on increasing the size of the seal to diameters required for the turbine rim locations.

Conclusions

A foil thrust bearing has been demonstrated which will form the primary rotating interface for a film riding face seal. This foil thrust bearing will be combined with a secondary seal that will allow the entire assembly to translate axially relative to a static attachment. The complete assembly will form a hybrid foil/film riding face seal that shows much promise at being sufficiently flexible to enable operation in a gas turbine engine. Segmentation of the seal ring into a multiplicity of independently functioning tilt pad bearings allows the seal to track circumferential out-of-flatness of the rotating mating ring. Fabrication of a complete seal assembly to determine leakage performance remains to be accomplished.

References

1. Munson, J., Steinetz, B., & Hendricks, R., "Advanced Seal Technology Goal in Meeting Next Generation Turbine Engine Goals," NATO Research and Technology Organization – Applied Vehicle Technology Panel Symposium, Toulouse, France, May 1998
2. Short, J.F., "Advanced Brush Seal Development," 32nd Joint Propulsion Conference, July 1996, AIAA paper No. 96-2907
3. Chupp, R.E., "Update on Brush Seal Development for Large Industrial Gas Turbines," 32nd Joint Propulsion Conference, July 1996, AIAA paper No. AIAA 96-3306
4. Dobeck, L.J., "Development of Mainshaft Seals for Advanced Air Breathing Propulsion Systems," Pratt & Whitney Aircraft, NASA CR-121177 (1973)
5. Lynwander, P., "Development of Helicopter Engine Seals," AVCO-Lycoming, NASA CR-134647 (1973)
6. Lynwander, P., "Self-Acting Seals for Helicopter Engines," AVCO-Lycoming, NASA CR-134940, (1975)
7. O'Brien, M., "Development of a Short Length Self-Acting Seal," AVCO-Lycoming, NASA CR-135159, (1976)
8. Munson, J. And Pecht, G., "Development of Film Riding Face Seals for a Gas Turbine Engine," STLE Tribology Transactions, V35(1992),1,65-70
9. Gardener
10. Hesje, P.E. and Peterson, R.A., "Mechanical Dry Seal Applied to Pipeline (Natural Gas) Centrifugal Compressors," ASME-ASLE 1984 Joint Lubr. Conf. Preprint 84-GT-3
11. Tseng
12. Bagepalli, B., et.al., "Dynamic Analysis of an Aspirating Face Seal for Aircraft-Engine Application," 32nd Joint Propulsion Conference, July 1996, AIAA paper No. 96-2803
13. Wolfe, C.E., et.al., "Full Scale Testing and Analytical Validation of an Aspirating Face Seal," 32nd Joint Propulsion Conference, July 1996, AIAA paper No. 96-2802
14. Agrawal, G., "Foil Air/Gas Bearing Technology ~ An Overview," ASME preprint 97-GT-347 (1997)

Dedication

The authors would like to thank the NAWC-AD for their encouragement, and generous support of this work over the years.

-
- 1 Munson, J., Steinetz, B., & Hendricks, R., "Advanced Seal Technology Goal in Meeting Next Generation Turbine Engine Goals," NATO Research and Technology Organization – Applied Vehicle Technology Panel Symposium, Toulouse, France, May 1998
 - 2 Short, J.F., "Advanced Brush Seal Development," 32nd Joint Propulsion Conference, July 1996, AIAA paper No. 96-2907
 - 3 Chupp, R.E., "Update on Brush Seal Development for Large Industrial Gas Turbines," 32nd Joint Propulsion Conference, July 1996, AIAA paper No. AIAA 96-3306
 - 4 Dobeck, L.J., "Development of Mainshaft Seals for Advanced Air Breathing Propulsion Systems," Pratt & Whitney Aircraft, NASA CR-121177 (1973)
 - 5 Lynwander, P., "Development of Helicopter Engine Seals," AVCO-Lycoming, NASA CR-134647 (1973)
 - 6 Lynwander, P., "Self-Acting Seals for Helicopter Engines," AVCO-Lycoming, NASA CR-134940, (1975)
 - 7 O'Brien, M., "Development of a Short Length Self-Acting Seal," AVCO-Lycoming, NASA CR-135159, (1976)
 - 8 Munson, J. And Pecht, G., "Development of Film Riding Face Seals for a Gas Turbine Engine," STLE Tribology Transactions, V35(1992),1,65-70
 - 9 Gardener
 - 10 Hesje, P.E. and Peterson, R.A., "Mechanical Dry Seal Applied to Pipeline (Natural Gas) Centrifugal Compressors," ASME-ASLE 1984 Joint Lubr. Conf. Preprint 84-GT-3
 - 11 Tseng
 - 12 Bagepalli, B., et.al., "Dynamic Analysis of an Aspirating Face Seal for Aircraft-Engine Application," 32nd Joint Propulsion Conference, July 1996, AIAA paper No. 96-2803
 - 13 Wolfe, C.E., et.al., "Full Scale Testing and Analytical Validation of an Aspirating Face Seal," 32nd Joint Propulsion Conference, July 1996, AIAA paper No. 96-2802
 - 14 Agrawal, G., "Foil Air/Gas Bearing Technology ~ An Overview," ASME preprint 97-GT-347 (1997)