

AD \_\_\_\_\_

Award Number: DAMD17-00-1-0366

TITLE: Miniaturized DNA Biosensor for Decentralized Breast-Cancer Screening

PRINCIPAL INVESTIGATOR: Joseph Wang, Ph.D.

CONTRACTING ORGANIZATION: New Mexico State University  
Las Cruces, New Mexico 88003

REPORT DATE: June 2001

TYPE OF REPORT: Annual

PREPARED FOR: U.S. Army Medical Research and Materiel Command  
Fort Detrick, Maryland 21702-5012

DISTRIBUTION STATEMENT: Approved for Public Release;  
Distribution Unlimited

The views, opinions and/or findings contained in this report are those of the author(s) and should not be construed as an official Department of the Army position, policy or decision unless so designated by other documentation.

20010727 070

# REPORT DOCUMENTATION PAGE

Form Approved  
OMB No. 074-0188

Public reporting burden for this collection of information is estimated to average 1 hour per response, including the time for reviewing instructions, searching existing data sources, gathering and maintaining the data needed, and completing and reviewing this collection of information. Send comments regarding this burden estimate or any other aspect of this collection of information, including suggestions for reducing this burden to Washington Headquarters Services, Directorate for Information Operations and Reports, 1215 Jefferson Davis Highway, Suite 1204, Arlington, VA 22202-4302, and to the Office of Management and Budget, Paperwork Reduction Project (0704-0188), Washington, DC 20503

1. AGENCY USE ONLY (Leave blank)	2. REPORT DATE June 2001	3. REPORT TYPE AND DATES COVERED Annual (1 Jun 00 - 31 May 01)
----------------------------------	-----------------------------	---

4. TITLE AND SUBTITLE Miniaturized DNA Biosensor for Decentralized Breast-Cancer Screening	5. FUNDING NUMBERS DAMD17-00-1-0366
---	--

6. AUTHOR(S)  
Joseph Wang, Ph.D.

7. PERFORMING ORGANIZATION NAME(S) AND ADDRESS(ES)  
New Mexico State University  
Las Cruces, New Mexico 88003  
  
E-Mail: [joewang@nmsu.edu](mailto:joewang@nmsu.edu)

8. PERFORMING ORGANIZATION  
REPORT NUMBER

9. SPONSORING / MONITORING AGENCY NAME(S) AND ADDRESS(ES)  
U.S. Army Medical Research and Materiel Command  
Fort Detrick, Maryland 21702-5012

10. SPONSORING / MONITORING  
AGENCY REPORT NUMBER

11. SUPPLEMENTARY NOTES

12a. DISTRIBUTION / AVAILABILITY STATEMENT  
Approved for Public Release; Distribution Unlimited

12b. DISTRIBUTION CODE

13. ABSTRACT (*Maximum 200 Words*)

The use of DNA testing as an important component of breast cancer diagnosis has been increasing rapidly during the 1990s. The goal of this research is to develop, optimize, and test a miniaturized sensing system for the rapid and reliable genetic screening detection of breast-cancer. In accordance to our original goal our studies have focused on various fundamental and practical aspects of electrical detection of DNA segments specific to the breast-cancer gene BRCA1. We have made a substantial progress, and introduced new electrical strategies and routes for improving the reliability of devices for genetic screening of breast-cancer. In particular, we have successfully combined the unique amplification features of new metal nanoparticles or enzyme tags, with an effective magnetic separation (isolation) of the duplex, and a powerful electrical detection for achieving the task of selective and sensitive breast-cancer screening. Additional developmental work, particularly further improvements in the sensitivity and sample preparation, is in progress towards the realization of wide-scale decentralized screening for breast cancer.

14. SUBJECT TERMS  
Decentralized testing, Electrochemical detection

15. NUMBER OF PAGES  
29

16. PRICE CODE

17. SECURITY CLASSIFICATION  
OF REPORT  
Unclassified

18. SECURITY CLASSIFICATION  
OF THIS PAGE  
Unclassified

19. SECURITY CLASSIFICATION  
OF ABSTRACT  
Unclassified

20. LIMITATION OF ABSTRACT  
Unlimited

## Table of Contents

COVER.....	1
SF 298.....	2
<b>Introduction.....</b>	<b>4</b>
BODY.....	4
<b>Key Research Accomplishments.....</b>	<b>7</b>
<b>Reportable Outcomes.....</b>	<b>9</b>
<b>Conclusions.....</b>	<b>9</b>
<b>References.....</b>	<b>10</b>
<b>Appendices.....</b>	<b>11</b>

## Introduction

Wide-scale genetic testing requires the development of easy-to-use, fast, inexpensive, miniaturized analytical devices. Traditional methods for detecting DNA hybridization are too slow and labor intensive. Biosensors offer a promising alternative for faster, cheaper, and simpler nucleic-acid assays. DNA hybridization biosensors commonly rely on the immobilization of a single-stranded (ss) oligonucleotide probe onto a transducer surface to recognize - by hybridization - its complimentary target sequence.

Electrochemical devices have received considerable attention in the development of sequence-specific DNA hybridization biosensors. Such devices rely on the conversion of the DNA base-pair recognition event into a useful electrical signal. The high sensitivity of such devices, coupled to their compatibility with modern microfabrication technologies, portability, low cost (disposability), minimal power requirements, and independence of sample turbidity or optical pathway, make them excellent candidates for centralized and decentralized DNA diagnostics. Direct electrical reading of DNA hybridization thus offers great promise for developing simple, rapid, and user-friendly DNA sensing devices (in a manner analogous to miniaturized blood-glucose meters). Recent efforts have led to a host of new strategies for electrical detection of DNA hybridization (1,2).

The goal of this research is to develop, optimize, and test a miniaturized sensing system for the rapid and reliable genetic screening detection of breast-cancer. The realization of instant point-of-care DNA testing requires proper attention to major challenges of mismatch discrimination, signal amplification, non-specific binding, as well as the integration of the sample preparation with the actual DNA detection on a single microchip platform. Such challenges are being met by coupling innovative biosensor strategies with "Lab-on-Chip" technologies. Such user-friendly operation, on a chip platform, would allow testing for breast cancer to be performed more reliably, rapidly, and inexpensively, in a decentralized setting, and will thus accelerate the realization of wide-scale breast-cancer screening.

### Body: Progress Report

This report summarizes our activity over the first year of the project (i.e., the 7/00-6/01 period). In accordance to our original goal our studies have focused on various fundamental and practical aspects of electrical detection of DNA segments specific to the breast-cancer gene BRCA1. As described in this section, we have made a substantial progress, and introduced new strategies and routes for improving the reliability of devices for genetic screening of breast-cancer. This 11-mos activity has already resulted in 5 research papers (published or in press in major journals; see attached list), and several presentations in major meetings. (Several more publications are expected in the late part of 2001.) Such findings pave the way to major improvements in the biosensing of DNA and offer innovative routes for simple, rapid, and user-friendly breast-cancer screening devices.

We developed a renewable and simple DNA hybridization electrochemical biosensor based on a pencil electrode transducer (3). The surface of this biosensor can be renewed rapidly, by a simple mechanical extrusion, hence obviating the need for an additional regeneration step. The sensor thus responds rapidly to the 'switching' between target and

noncomplementary oligonucleotide solutions, with the use of fresh surfaces erasing memory effects. The intrinsic redox activity of the target DNA is employed for label-free detection of the duplex formation. Relevant experimental parameters were examined and systematically optimized. The selectivity of the new device was demonstrated for the detection of a single-point mutation in the BRCA1 breast cancer gene. For example, Figure 1 displays the selectivity of the renewable DNA biosensor in connection to the detection of a specific point mutation in the BRAC1 gene. Such replacement of guanine (G) with thymine (T) in the E908X-WT oligonucleotide has been linked to familial breast and ovarian cancers. It shows the response to sequential exposures of the device to solutions of the target (T) and mismatch (M) sequences. A large guanine peak (of ca. 19.2ms) is observed following the immersion in the target solution. In contrast, significantly smaller signals (of around 5.5ms) are observed following exposure to the single-base mismatch oligonucleotide. Note that such high selectivity was achieved without a stringent control of the hybridization conditions. An even higher specificity could be achieved in connection to the use of more selective PNA probes (discussed below).

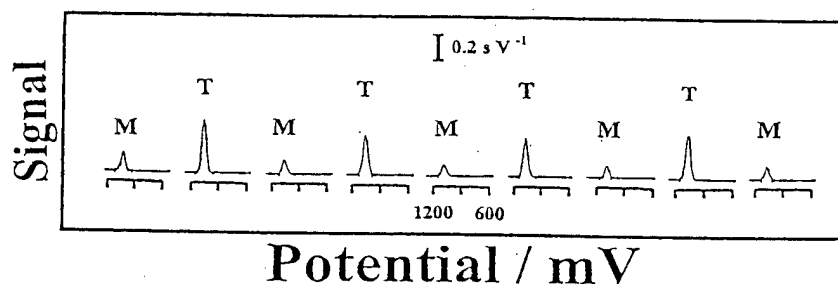

**Figure 1.** chronopotentiometric hybridization signals following sequential exposures of individual pencil sensor surfaces to (M) one base-mismatch E908X-MUT solution (100mg/l) and (T) E908-WT solution (100mg/l) as a target. Other conditions, as in Figure 1(A,a). (From ref. 3.)

Such low-cost, renewable graphite transducers provide an attractive alternative to conventional carbon electrodes used for transducing DNA hybridization. By eliminating the needs for a regeneration step and an external indicator, the device offers a greatly simplified operation and holds promise for decentralized genetic testing.

A major portion of our effort has been devoted to the issues of specificity and sensitivity that are crucial for the realization of reliable breast-cancer screening. One route is to couple the high degree of signal amplification of highly-branched dendrimers with the remarkable mismatch discrimination of PNA oligomers. We are examining the synthesis of such PNA dendrimers in collaboration with Polyprobe Inc. Additional innovative routes for dramatically enhancing the selectivity and enhancing/amplifying the response have been explored (while waiting for the PNA dendrimers). In particular, we have successfully combined an effective magnetic separation (isolation) of the duplex with the amplification features of new metal nanoparticles or enzyme tags for achieving the task of selective and sensitive breast-cancer screening.

For example, we developed a new genomagnetic electrochemical assay of BRCA1 DNA segments, based on the coupling of a new biomagnetic processing technique with the use of an alkaline-phosphatase enzyme label and single-use microfabricated thick-film electrochemical transducers (4, Figure 2; see Appendix). The new biomagnetic processing technology combines efficient magnetic mixing and separation into a single mechanism (5). Such MixSep™ Technology process thus integrates, on the same platform, the isolation of the target nucleic acid with an efficient low-volume magnetic mixing during the hybridization, enzyme-association, and substrate-enzyme reaction steps (Figure 2, b, c, and d, respectively). Up to 12 assays can be performed simultaneously using the same compact unit. The efficient magnetic 'removal' of nonhybridized DNA is particularly attractive for electrical biosensing of DNA hybridization that is often hampered by errors due to non-specifically adsorbed oligonucleotides. The minimization of contributions from these nonhybridized nucleic acids has been demonstrated for the detection of the BRCA1 target DNA in the presence of large excess of noncomplementary oligonucleotides. Such successful coupling of the biomagnetic separation/mixing platform with the advantages and improvements of AP enzyme labels and pulse-voltammetric (electrical) detection of the enzymatically-liberated naphthol product at disposable screen-printed strip electrodes are particularly attractive for decentralized DNA testing.

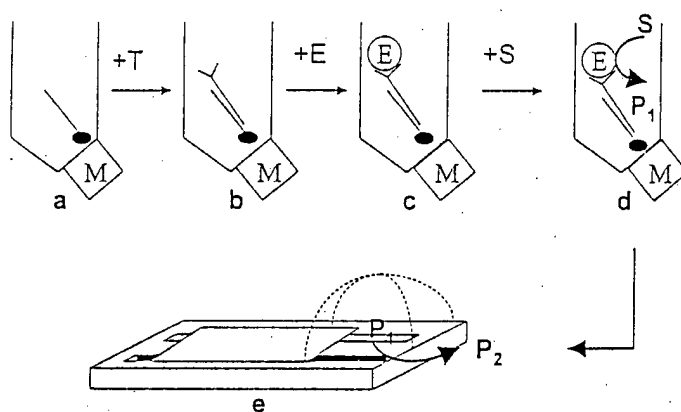

Figure 2: Schematic representation of the analytical protocol: (a) introduction of the oligomer-coated beads; (b) addition of the biotinylated target (T) oligomer – hybridization event; (c) addition of the streptavidin-enzyme (E=alkaline phosphatase) and its conjugation with the biotinylated target (of the duplex); (d) addition and enzymatic reaction of the substrate (S= $\alpha$ -naphthyl phosphate); (e) placement of a droplet of the supernatant onto the thick-film electrode for the voltammetric measurement.(From ref. 4.)

Instead of using an enzyme label, it is possible to employ a metal particle tag and detect it with the most sensitive electrochemical technique of stripping analysis. Accordingly, we developed such new electrochemical stripping metallogenomagnetic protocol, combining the inherent signal amplification of stripping metal analysis, with effective (magnetic) discrimination against nonhybridized DNA, the use of microliter sample volumes and disposable transducers (6). The resulting protocol consists of the hybridization of a

biotinylated target strand to oligonucleotide-probe coated magnetic beads, followed by binding of the streptavidin-coated gold nanoparticles to the captured target, and an acid dissolution and stripping-potentiometric detection of the gold tag at a disposable thick-film carbon electrode (Figure 3). The influence of relevant experimental variables, including the amounts of the gold nanoparticles and the magnetic beads, the duration of the hybridization- and gold dissolution steps, and parameters of the potentiometric stripping operation upon the hybridization signal was examined and optimized. The attractive performance of the new electrochemical metallogenomagnetic assay is illustrated in Figure 4 for the detection of DNA segments related to the breast-cancer BRCA1 gene in the presence of excess of mismatched and noncomplementary strands.

A related study demonstrated that a dramatic enhancement of the response towards the BRCA1 DNA target could be achieved via silver precipitation (on the gold particles tag) and subsequent stripping detection of the dissolved silver (7). Such coupling of a nanoparticle-promoted silver precipitation with the remarkable sensitivity of stripping metal analysis offered a dramatic enhancement of the hybridization response. The dramatic signal amplification advantage of the silver-enhanced colloidal gold stripping detection was combined with an efficient magnetic removal of non-complementary DNA. Variables influencing the response to the BRCA1 DNA target were assessed and optimized, and the analytical performance was characterized. Hand-held, battery-operated stripping instruments, developed in our laboratory for on-site detection of trace metals, could facilitate such decentralized DNA diagnostic applications. The use of dendritic structures (bearing multiple nanoparticles) and of PNA probes should impart additional improvements in the sensitivity and selectivity, respectively.

## **Key Research Accomplishments**

During the first year of this project we introduced new and innovative electrical strategies and routes for improving the reliability of devices for genetic screening of breast-cancer. In particular, we have successfully combined the unique amplification features of new metal nanoparticles or enzyme tags, with an effective magnetic separation (isolation) of the duplex, and a powerful electrical detection for achieving the task of selective and sensitive breast-cancer screening (4,6,7). We also developed a renewable and simple DNA hybridization electrochemical biosensor based on a pencil electrode transducer (3). Such developments address the challenges of mismatch discrimination, signal amplification, non-specific adsorbates, and should facilitate the realization of instant point-of-care breast-cancer testing.

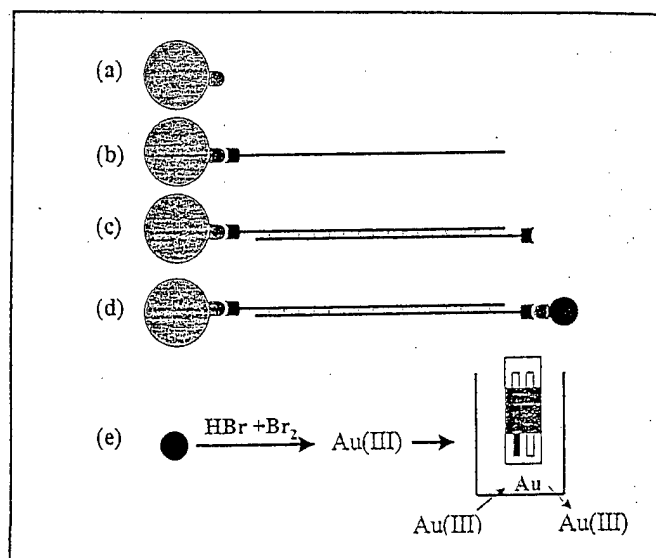

**Figure 3.** Schematic representation of the analytical protocol: (a) introduction of the streptavidin-coated beads; (b) immobilization of the biotinylated probe onto the magnetic beads; (c) addition of the biotinylated target - the hybridization event; (d) addition and capture of the streptavidin-gold nanoparticles; (e) dissolution and electrochemical stripping detection of the gold tag and its electrochemical stripping detection. (From ref. 6.)

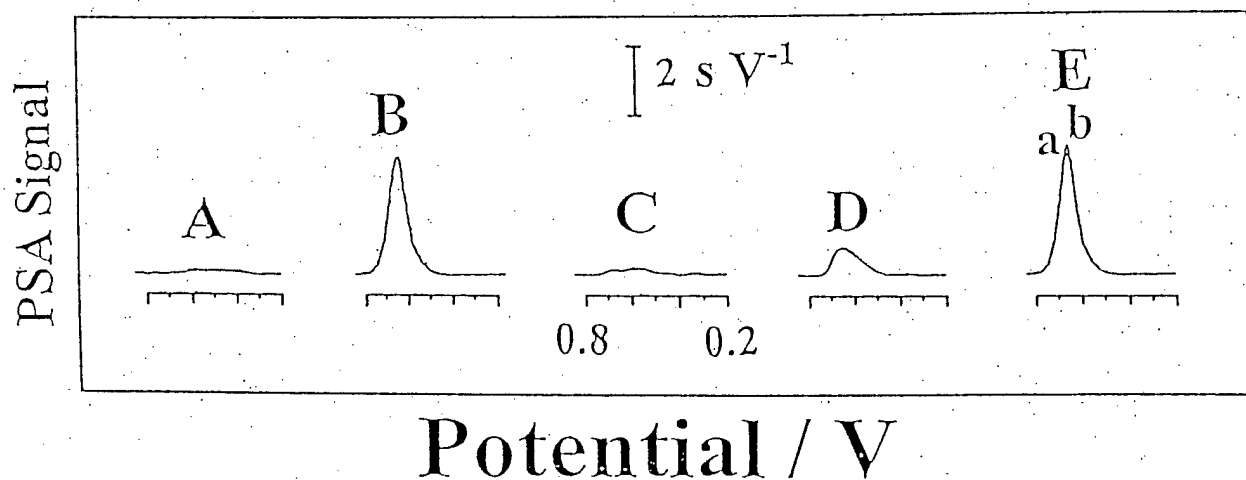

**Figure 4.** Electrical hybridization response to 0  $\mu\text{g/mL}$  target (A); 25  $\mu\text{g/mL}$  BRCA1 Target (B and E(a)); 100  $\mu\text{g/mL}$  noncomplementary strand (C); 40  $\mu\text{g/mL}$  three-base mismatched BRCA1 strand (D); a mixture of 25  $\mu\text{g/mL}$  target and 100  $\mu\text{g/mL}$  noncomplementary strands (E, b). Hybridization time, 20min; amount of magnetic beads, 90 $\mu\text{g}$ ; amount of 5nm streptavidin-coated gold particles,  $7.6 \times 10^{10}$ . (From ref. 6.)

## Reportable Outcomes

Papers submitted, accepted or published:

- a. "Genomagnetic Electrochemical Assays of DNA Hybridization", J. Wang, D. Xu, R. Polsky, and E. Arzum, submitted (Talanta, special issue).
- b. "Pencil-based renewable Biosensor for Label-free Electrochemical Detection of DNA Hybridization", J. Wang and A. Kawde, Anal. Chim. Acta, 431(2000)219.
- c. "Metal-Nanoparticle Based Electrochemical Stripping Detection of DNA Hybridization", J. Wang, D. Xu, R. Polsky, and A. Kawde, submitted (to Anal. Chem.).
- d. "Silver-Enhanced Colloidal Gold Electrical Detection of DNA Hybridization", J. Wang, R. Polsky, D. Xu, submitted (to J. Am. Chem. Soc.).
- e. "DNA Biosensors and Gene Chips", J. Wang, Nucleic-Acid Research (**Invited Review**), 28(2000)3011.

## Conclusions

Electrochemical detection of DNA hybridization offers great promise for developing simple, rapid, and user-friendly DNA sensing devices for decentralized breast-cancer testing. Our initial findings have already paved the way to major improvements in the electrical biosensing of DNA segments specific to the breast-cancer gene BRCA1. The realization of instant point-of-care DNA testing would require additional developmental work. Particular attention should be given to the major challenges of mismatch discrimination, signal amplification, non-specific adsorbates, as well as integration of the DNA detection with automated sample preparation on a single microchip platform. The new microfluidic devices will contain multiple microstructures (functional elements) and related microchannel network for integrating various processes, including sample collection, DNA extraction, reagent mixing and amplification, with the actual hybridization detection. The proposed chip layout will thus accommodate the necessary microstructures for the DNA extraction, reagent mixing, PCR amplification, and electrochemical biosensing. During the 2<sup>nd</sup> and 3<sup>rd</sup> years of the effort we thus expect to combine the signal amplification features of dendritic nucleic acids and metal particles assays with the specificity of PNA probes, and on-chip sample manipulation and integration. We are currently assembling a microfabrication laboratory that will allow (starting the 2001 Fall period) to micromachine the microfluidic devices essential for such on-chip high throughput automated operation. Besides addressing the issues of sensitivity and sample pretreatment, we are also integrating a battery-operated electronic microcontroller (potentiostatic circuitry and 'smart' data processor), as well as the reference and counter electrodes, on the pencil holder.

## References

1. J. Wang, Chem. Eur. J. 5 (1999)1681.
2. E. Palecek and M. Fojta, Anal. Chem. 73(2001)75A.
3. J. Wang and A. Kawde, Anal. Chim. Acta, 431(2000)219.
4. J. Wang, D. Xu, R. Polsky, and E. Arzum, submitted (to Talanta; special DNA issue).
5. "MCB1200-MixSep Technology",  
[http://www.sigris.com/mcb\\_technology.html](http://www.sigris.com/mcb_technology.html)
6. J. Wang, D. Xu, R. Polsky, and A. Kawde, submitted (to Anal. Chem.)
7. J. Wang, R. Polsky, D. Xu, submitted (to JACS).

## Appendices

Papers resulted from our first year effort:

1. "Pencil-based renewable Biosensor for Label-free Electrochemical Detection of DNA Hybridization", J. Wang and A. Kawde, *Anal. Chim. Acta*, 431(2000)219.
2. "DNA Biosensors and Gene Chips", J. Wang, *Nucleic-Acid Research (Invited Review)*, 28(2000)3011.
3. "Genomagnetic Electrochemical Assays of DNA Hybridization", J. Wang, D. Xu, R. Polsky, and E. Arzum, submitted (*Talanta*, special issue).
4. "Metal-Nanoparticle Based Electrochemical Stripping Detection of DNA Hybridization", J. Wang, D. Xu, R. Polsky, and A. Kawde, submitted (to *Anal. Chem.*).
5. "Silver-Enhanced Colloidal Gold Electrical Detection of DNA Hybridization", J. Wang, R. Polsky, D. Xu, submitted (to *JACS*).



ELSEVIER

Analytica Chimica Acta 431 (2001) 219–224

**ANALYTICA  
CHIMICA  
ACTA**

www.elsevier.com/locate/aca

# Pencil-based renewable biosensor for label-free electrochemical detection of DNA hybridization

Joseph Wang\*, Abdel-Nasser Kawde

*Department of Chemistry and Biochemistry, New Mexico State University, Las Cruces, NM 88003, USA*

Received 25 July 2000; received in revised form 21 November 2000; accepted 21 November 2000

## Abstract

The characteristics and advantages of a renewable DNA hybridization biosensor based on a pencil electrode transducer are described. The surface of this biosensor can be renewed rapidly, by a simple mechanical extrusion, hence, obviating the need for an additional regeneration step. The sensor, thus, responds rapidly to the 'switching' between target and non-complementary oligonucleotide solutions, with the use of fresh surfaces erasing memory effects. The intrinsic redox activity of the target DNA is employed for detecting the duplex formation. Relevant experimental parameters were examined and optimized. The selectivity of the new device was demonstrated for the detection of a single-point mutation in the BRCA1 breast cancer gene. Such low-cost, renewable graphite transducers provide an attractive alternative to conventional carbon electrodes used for transducing DNA hybridization. By eliminating the needs for a regeneration step and an external indicator, the device offers a greatly simplified operation and holds promise for decentralized genetic testing. © 2001 Elsevier Science B.V. All rights reserved.

*Keywords:* DNA hybridization; Mutation detection; Biosensor; Pencil electrode; Breast cancer gene

## 1. Introduction

DNA hybridization biosensors hold an enormous promise for a fast and simple diagnosis of genetic diseases [1,2]. Such devices rely on the immobilization of a single-stranded (ss) oligonucleotide probe onto a miniaturized physical transducer to selectively recognize its complementary (target) sequence in a sample solution. Changes in optical or electrochemical properties are usually used for detecting the duplex formation. The high sensitivity of electrochemical transducers, coupled with their compatibility with miniaturization/microfabrication technologies make

them very attractive for the shrinking of DNA diagnostics [3,4]. Most electrochemical DNA biosensors have relied on traditional gold or carbon disk electrode transducers. Screen-printed (thick-film) transducers have also been proposed for facilitating on-site DNA testing [5,6]. New, easy-to-use electrodes are urgently needed for accelerating the realization of large-scale hybridization assays.

This article describes the characterization and attractive performance of a renewable DNA hybridization biosensor based on a graphite pencil electrode transducer. Pencil writing devices were employed previously in electroanalytical chemistry, e.g. for anodic stripping voltammetric measurements of trace metals [7] or for adsorptive stripping potentiometry of nucleic acids [8]. The present study demonstrates that the pencil electrode is very suitable for supporting the

\* Corresponding author. Tel.: +1-505-646-2140;  
fax: +1-505-646-6033.  
E-mail address: joewang@nmsu.edu (J. Wang).

oligonucleotide probe layer and transducing the DNA hybridization event. Particularly attractive for routine DNA testing is the convenient and rapid (mechanical) surface renewal that obviates the need for an additional regeneration step. Conventional DNA biosensors often require thermal or chemical regeneration steps, involving prolonged incubation in hot water, urea, or sodium hydroxide solutions. In an effort to perform DNA assays more easily and rapidly, the operation of the new renewable electrodes has been combined with an indicator-free chronopotentiometric detection based on the intrinsic redox activity of the target guanine residue [9]. Such a simplified protocol offers the advantages of the appearance of a sensitive signal (over a flat baseline) following the hybridization. The utility of the renewable label-free electrochemical biosensor for the detection of single-base mutated oligonucleotides linked to breast cancer is demonstrated. Such characteristics, optimization, and testing of the pencil-based DNA biosensor are described in the following sections.

## 2. Experimental

### 2.1. Apparatus

Chronopotentiometric measurements were performed with a potentiometric stripping unit PSU20 (Radiometer) controlled by a PC using the TAP2 software (Radiometer). The electrode system consisted of the 'pencil' working electrode, a Ag/AgCl (3 M NaCl) reference electrode (Model RE-1, BAS) and a platinum counter electrode.

A Pentel pencil Model P205 (Japan) was used as a holder for the pencil lead. Electrical contact with the lead was achieved by soldering a metallic wire to the metallic part that holds the lead in place inside the pencil. The pencil was fixed vertically with 8 mm of the pencil lead extruded outside and 6 mm of the lead immersed in the solution. Such length corresponds to an active electrode area of 9.82 mm<sup>2</sup>. Details of the pencil electrode were described earlier [8]. An array of 300  $\mu$ l glass wells was used for accommodating the immobilization, hybridization, detection, and wash solutions. Stirring was achieved with a 5 mm magnetic stirring bar.

### 2.2. Working electrode materials

The pencil leads were obtained from Pentel Co. LTD, Japan and named Hi-polymer Super C505 (black lead) of types 6H, HB, F, B, and 4H. All leads had a total length of 60 mm and a diameter of 0.5 mm. The pencil leads were used as-received.

### 2.3. Reagents

Sigma provided the sodium acetate buffer (3 M, pH 5.2 at 25 °C; Catalog no. S-7899), sodium phosphate dibasic (Catalog no. S-3264), sodium phosphate monobasic (Catalog no. S-3139) and sodium chloride (Catalog no. S-3014). All chemicals were free of RNase and DNase and were used as-received. All water and pipet tips were sterilized by autoclaving for 30 min (120 °C).

Oligo(dC)<sub>20</sub>, oligo(dG)<sub>20</sub>, oligo(dA)<sub>20</sub>, inosine-substituted E908X-WT, E908X-WT and E908X-Mut [10] oligonucleotides, were acquired from Life Technologies (Grand Island, NY). The latter had the following sequences (with the bold letter represents the base substitution):

Immobilized probe:

E908X-WT(1)



Target:

E908X-WT



Non-complementary oligomer:

E908X-Mut



Stock solutions (1000 mg/l) of the various oligonucleotides were prepared with autoclaved water and kept frozen.

### 2.4. Procedure

Each measurement was performed using a new 6 mm long graphite lead surface, and involved the probe immobilization, the hybridization, and chronopotentiometric detection steps.

#### 2.4.1. Immobilization of the probe

A short (30 s) electrochemical pre-treatment at +1.4 V (using the blank acetate buffer solution; 0.2 M, pH 5.0) preceded the immobilization step. A pre-treated pencil lead electrode was immersed in a stirred 200  $\mu$ l acetate buffer solution containing the oligo(dC)<sub>20</sub> (or inosine-substituted E908X-WT oligonucleotide) probe; an ‘immobilization’ potential of +0.50 V was applied for 2 min.

#### 2.4.2. Hybridization

The electrode was rinsed with 5 mM phosphate buffer (pH 7.0) for 5 s and was immersed in the stirred target solution (0.1 M NaCl/0.05 M phosphate buffer, pH 7.0; 200  $\mu$ l) for a desired time, while holding its potential at +0.5 V.

#### 2.4.3. Chronopotentiometric transduction

The electrode was then rinsed with 0.2 M acetate buffer for 5 s, and transferred to a quiescent acetate buffer solution (0.2 M, pH 5.0). The chronopotentiometric detection of the target guanine was accomplished using a constant current of +5.0  $\mu$ A and a final potential of +1250 mV.

### 3. Results and discussion

Early work in this laboratory demonstrated the utility of pencil electrodes for adsorptive stripping potentiometric measurements of trace nucleic acids [8]. The effective adsorptive pre-concentration of DNA and RNA onto composite graphite surface was, thus, combined with the electro-oxidation of the accumulated nucleic acid. Here, we expand the scope of pencil electrodes as transducers for DNA hybridization biosensors. As desired for rapid and simplified decentralized testing, the new renewable biosensor has been combined with a label-free protocol based on the intrinsic redox activity of the target guanine residue in connection to the use of guanine-free (inosine-substituted) probes [9]. Fig. 1A displays chronopotentiometric hybridization signals at the oligo(dC)<sub>20</sub>-modified pencil electrode following sequential exposures of new surfaces to solutions of the target oligo(dG)<sub>20</sub> (a) and non-complementary oligo(dA)<sub>20</sub> (b) oligonucleotides. The renewable sensor responds rapidly to such ‘switching’ between target and non-complementary

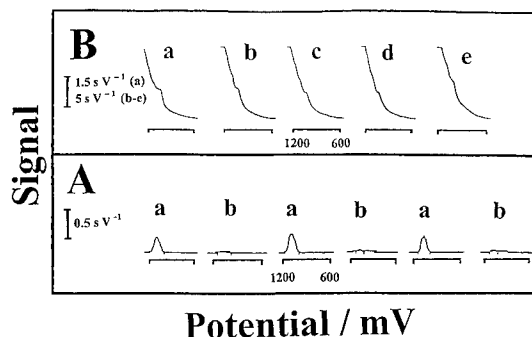

Fig. 1. (A) Chronopotentiometric hybridization signals following sequential 2 min exposures of individual oligo(dC)<sub>20</sub>-coated pencil sensor surfaces to 100 mg/l solutions: (a) of the target (oligo(dG)<sub>20</sub>); and (b) the non-complementary (oligo(dA)<sub>20</sub>) in a stirred 0.1 M NaCl/0.5 M phosphate buffer (pH 7.0) solution at +0.5 V, followed by a 5 s rinse in acetate buffer solution (0.2 M, pH 5.0), using a 6 mm long 6H pencil lead. Pre-treatment at +1.40 V for 30 s, followed by a 2 min immobilization at +0.50 V using the stirred 20 mg/l oligo(dC)<sub>20</sub>/acetate buffer solution. The stripping was performed in a quiescent 0.2 M acetate buffer solution (pH 5.0) using an applied oxidative current of +5.0  $\mu$ A. (B) Evaluation of different types of pencil leads. Chronopotentiometric hybridization signals (before baseline correction) recorded after a 2 min hybridization. Leads: 6H (a); HB (b); F (c); B (d) and 4H (e). Other conditions and concentrations, as in Fig. 1(A).

oligonucleotide solutions, with the use of fresh surfaces erasing memory effects. While a well-defined guanine oxidation signal is observed in the presence of the target (a), no response is observed for the non-complementary sequence (b). The response is not affected by residuals from the previous target signal, hence, obviating the need for prolonged chemical or thermal regeneration steps. The absence of carry-over effects is coupled to a stable guanine hybridization signal. Notice also the favorable signal-to-background characteristics despite the extreme peak potential. Such a favorable response is attributed to the use of the computerized chronopotentiometric transduction mode (with its sophisticated data smoothing and baseline fitting).

We evaluated different types of pencil leads for transducing the hybridization event. For this purpose, we examined the actual signal-to-background characteristics using the raw (unprocessed) chronopotentiometric data. Such hybridization data, obtained at five different pencil leads following a 2 min hybridization, are compared in Fig. 1B. Substantial differences in

the target guanine signals and background response are observed at the various types of pencil leads, with the 6H one (a) displaying the most favorable signal-to-background characteristics. Large background signals, and inferior signal-to-background characteristics accompany the large guanine response observed at the other leads (b–e). The different profiles of Fig. 1B reflect changes in the composition and roughness of pencil leads. Pencil leads are composed of graphite, a polymeric binder, and other additives (e.g. clays). These, along with the different porosities, can influence both the probe immobilization (i.e. coverage and/or orientation) and the redox activity of the target guanine residue. All subsequent work, thus, employed the 6H pencil lead. Note that the HB pencil lead displayed the most favorable response in adsorptive stripping measurements of DNA [8].

Fig. 2 examines the influence of relevant experimental variables upon the response of the renewable pencil biosensor. The device permits an extrusion of graphite lead of different lengths. As expected, the

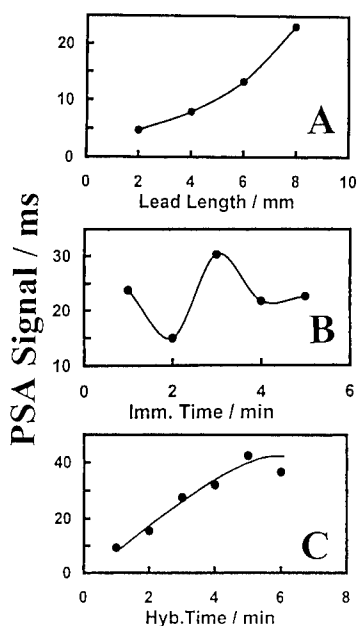

Fig. 2. Effect of the electrode length (A), probe immobilization time (B) and hybridization time (C): (A) immobilization and hybridization times, 2 min; (B) lead length, 6 mm, hybridization time, 2 min; (C) lead length, 6 mm, immobilization time, 2 min. Other conditions, as in Fig. 1A(a).

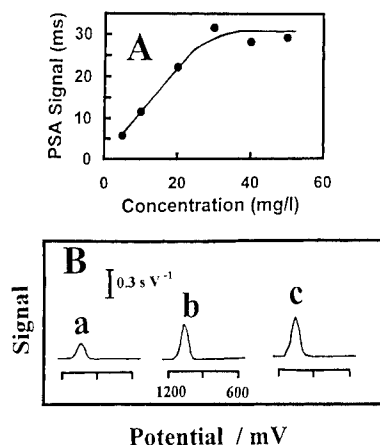

Fig. 3. (A) Calibration curve for target oligo(dG)<sub>20</sub> using a pencil lead (type 6H). (B) Potentiograms for different target oligo(dG)<sub>20</sub> concentrations: (a) 10; (b) 20; and (c) 30 mg/l. Probe immobilization time, 3 min. Other conditions, as in Fig. 1A(a).

length of the lead (i.e. its surface area) has a profound effect upon the hybridization signal (A). The target guanine peak increases slowly upon extending the length from 2 to 4 mm and more rapidly between 4 and 8 mm. All subsequent work employed 6 mm electrodes that allow 10 hybridization/detection cycles using a single 60 mm long lead. The probe immobilization time also has a marked effect upon the response (B). The signal decreases between 1 and 2 min immobilization, then rises to a maximum at 3 min, and decreases again between 3 and 4 min. The exact reason for this complex profile is not fully understood. It may reflect the fact that a higher surface coverage results in an unfavorable orientation, i.e. lower accessibility of the target and reduced hybridization efficiency. The extent of hybridization, and, hence, the sensitivity of the biosensor, are strongly dependent upon the duration of the hybridization reaction (C). As expected, the hybridization signal increases linearly with the hybridization time between 1 and 5 min, after which it levels off.

Quantitative evaluation is based on the dependence of the hybridization peak area on the concentration of the target DNA. Fig. 3 displays calibration data obtained with the indicator-free renewable biosensor. The chronopotentiometric response increases linearly with the target concentration up to 30 mg/l, and levels off at higher concentrations (A). Such

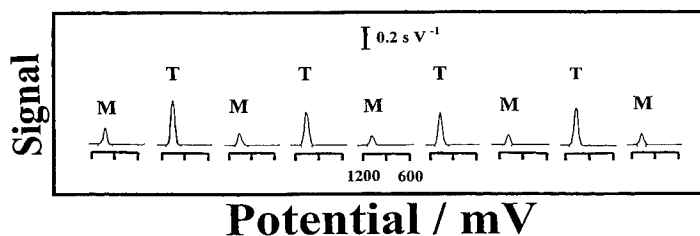

Fig. 4. Chronopotentiometric hybridization signals following sequential exposures of individual pencil sensor surfaces to (M) one base-mismatch E908X-Mut solution (100 mg/l) and (T) E908-WT solution (100 mg/l) as a target. Other conditions, as in Fig. 1A(a). See Section 2 for sequence information.

curvature reflects the saturation of surface hybridization sites.

The initial linear portion has a sensitivity of 1.033 ms/l/mg (with a correlation coefficient, 0.998). An extended linear range is expected in connection to shorter hybridization times. Typical guanine hybridization signals from this series, for target concentrations ranging from 10 to 30 mg/l, are also shown in Fig. 3B(a–c). A detection limit of around 0.5 mg/l, i.e. 100 ng in the 200  $\mu$ l sample volume used, can, thus, be estimated following a short (2 min) hybridization time. Longer (20–30 min) hybridization periods would allow the direct detection of sub (ng/ml) target concentrations. Yet, the detection of even lower levels, essential for routine clinical applications, would require the coupling of the sensor with a PCR amplification, use of dendritic DNA probes, or much longer hybridization times.

A major advantage of the new biosensor is its convenient and rapid mechanical renewal. Such renewal leads to a reproducible performance. The precision of the device was estimated from a series of six repetitive of the oligo(dG)<sub>20</sub> target (100 mg/l; conditions, as in Fig. 1A(a)). Such series resulted in a mean peak area of 26.7 ms, with a relative standard deviation of 3.0%, and no signal loss during the repetitive runs.

We assessed the selectivity of the renewable DNA biosensor, and demonstrated its utility in connection to the detection of a specific point mutation in the BRAC1 gene. Such replacement of guanine (G) with thymine (T) in the E908X-WT oligonucleotide has been linked to familial breast and ovarian cancers [10]. Fig. 4 displays the response to sequential exposures of the device to solutions of the target (T) and mismatch (M) sequences. A large guanine peak (of

ca. 19.2 ms) is observed following the immersion in the target solution. In contrast, significantly smaller signals (of around 5.5 ms) are observed following exposure to the single-base mismatch oligonucleotide. Note that such high selectivity was achieved without a stringent control of the hybridization conditions. Such mismatch discrimination indicates great promise for the diagnostics of breast cancer, although the analysis of real samples would require an amplification step (based on the detection limits reported above) and a proper sample processing. An even higher specificity could be achieved in connection to the use of more selective PNA probes [11]. We are also examining the use of controlled electric fields for imparting higher selectivity.

In conclusion, we have demonstrated the attractive performance of renewable pencil electrodes for the biosensing of DNA hybridization. Such performance compares favorably with that of conventional carbon electrodes commonly used for transducing DNA hybridization. The simple and fast regeneration step enhances the day-to-day practicality of the device and holds great promise for decentralized genetic testing. The new device, thus, offers a promising alternative for microfabricated (screen-printed) electrodes when fast and cheap hybridization assays are concerned. Even though the concept was demonstrated in connection to label-free chronopotentiometric detection, other electrochemical protocols can be readily combined with the renewable pencil biosensor. More developmental work, particularly further improvements in the sensitivity and sample preparation, would be required prior to the realization of decentralized clinical testing. Besides addressing the issues of sensitivity and sample pre-treatment, we are integrating a battery-operated

electronic microcontroller (potentiostatic circuitry and 'smart' data processor), as well as the reference and counter electrodes, on the pencil holder. We are also performing additional developmental work for addressing the needs of routine wide-scale breast cancer screening.

### Acknowledgements

J.W. acknowledges the financial support from the US Army Medical Research (Award no. DAMD17-00-1-0366) and the National Institutes of Health (Grant no. R01 14549-02). A.K. acknowledges a fellowship from the Egyptian government.

### References

- [1] T.K. Christopoulos, *Anal. Chem.* 71 (1999) 425.
- [2] J. Wang, *Anal. Chem.* 71 (1999) 328.
- [3] S.R. Mikkelsen, *Electroanalysis* 8 (1996) 15.
- [4] J. Wang, *Chem. Europ. J.* 5 (1999) 1681.
- [5] J. Wang, X. Cai, B. Tian, H. Shiraishi, *Analyst* 121 (1996) 965.
- [6] G. Marrazza, I. Chianella, M. Mascini, *Anal. Chim. Acta* 387 (1999) 297.
- [7] A.M. Bond, P.J. Mason, J. Schiewe, V. Vicente-Beckett, *Anal. Chim. Acta* 345 (1997) 67.
- [8] J. Wang, A. Kawde, E. Sahlin, *Analyst* 125 (2000) 5.
- [9] J. Wang, G. Rivas, J.R. Fernandes, J.L.L. Paz, M. Jiang, R. Waymire, *Anal. Chim. Acta* 375 (1998) 197.
- [10] D. Tong, M. Stimpfl, A. Reinthaller, N. Vavra, S. Mullauer-Ertl, S. Leodolter, R. Zeillinger, *Clin. Chem.* 45 (1999) 976.
- [11] J. Wang, *Biosensors Bioelectron.* 13 (1998) 757.

## SURVEY AND SUMMARY

# From DNA biosensors to gene chips

Joseph Wang\*

Department of Chemistry and Biochemistry, New Mexico State University, Las Cruces, NM 88003, USA

Received February 17, 2000; Revised May 30, 2000; Accepted June 26, 2000

### ABSTRACT

**Wide-scale DNA testing requires the development of small, fast and easy-to-use devices. This article describes the preparation, operation and applications of biosensors and gene chips, which provide fast, sensitive and selective detection of DNA hybridization. Various new strategies for DNA biosensors and gene chips are examined, along with recent trends and future directions. The integration of hybridization detection schemes with the sample preparation process in a 'Lab-on-a-Chip' format is also covered. While the use of DNA biosensors and gene chips is at an early stage, such devices are expected to have an enormous effect on future DNA diagnostics.**

### INTRODUCTION

Few scientific areas have witnessed dramatic changes of the magnitude observed recently in DNA diagnostics. With the completion of the human genome, we are just at the beginning of a revolution in genetic analysis. The information obtained from the project opens the door to tremendous analytical opportunities ranging from diagnostic tests for mutations to the assessment of medical treatment. To continue these advances, to exploit these opportunities, and to address the growing market needs in the 21st Century, future devices must link high performance, with speed, simplicity and low cost.

The aim of the present article is to review recent efforts in the areas of DNA biosensors, gene chips and miniaturized ('Lab-on-a-Chip') DNA analyzers. The goal is to connect recent activities in these closely-related areas, and to introduce the concepts of DNA biosensors and 'Lab-on-a-Chip' to the readers of this journal. DNA biosensors and gene chips are of considerable recent interest due to their tremendous promise for obtaining sequence-specific information in a faster, simpler and cheaper manner compared to traditional hybridization assays. Recent advances in developing such devices thus opens up new opportunities for DNA diagnostics. Although an attempt has been made to cover in this review the range of latest activities and trends, this is not a comprehensive review.

### DNA BIOSENSORS

Biosensors are small devices which utilize biological reactions for detecting target analytes (1). Such devices intimately

couple a biological recognition element (interacting with the target analyte) with a physical transducer that translates the biorecognition event into a useful electrical signal (Fig. 1). Common transducing elements, including optical, electrochemical or mass-sensitive devices, generate light, current or frequency signals, respectively. There are two types of biosensors, depending on the nature of the recognition event. Bioaffinity devices rely on the selective binding of the target analyte to a surface-confined ligand partner (e.g. antibody, oligonucleotide). In contrast, in biocatalytic devices, an immobilized enzyme is used for recognizing the target substrate. For example, sensor strips with immobilized glucose oxidase have been widely used for personal monitoring of diabetes.

DNA biosensors, based on nucleic acid recognition processes, are rapidly being developed towards the goal of rapid, simple and inexpensive testing of genetic and infectious diseases (2,3), and for the detection of DNA damage and interactions (4). Unlike enzyme or antibodies, nucleic acid recognition layers can be readily synthesized and regenerated for multiple use.

### Sequence-specific hybridization biosensors

Hybridization biosensors rely on the immobilization of a single-stranded (ss) DNA probe onto the transducer surface. The duplex formation can be detected following the association of an appropriate hybridization indicator or through other changes accrued from the binding event.

*Surface chemistry and biochemistry.* The immobilization of the nucleic acid probe onto the transducer surface plays an important role in the overall performance of DNA biosensors and gene chips. The immobilization step should lead to a well-defined probe orientation, readily accessible to the target (5,6). The environment of the immobilized probes at the solid surface depends upon the mode of immobilization and can differ from that experienced in the bulk solution. Depending upon the nature of the physical transducer, various schemes can be used for attaching the DNA probe to the surface. These include the use of thiolated DNA for self assembly onto gold transducers (gold electrodes or gold-coated piezoelectric crystals), covalent linkage to the gold surface via functional alkanethiol-based monolayers, the use of biotylated DNA for complex formation with a surface-confined avidin or streptavidin, covalent (carbodiimide) coupling to functional groups on carbon electrodes, or a simple adsorption onto carbon surfaces. As in solution-based hybridization assays, conditions for interfacial hybridization events (e.g. ionic strength, temperature,

\*Tel: +1 505 646 2140; Fax: +1 505 646 6033; Email: joewang@nmsu.edu

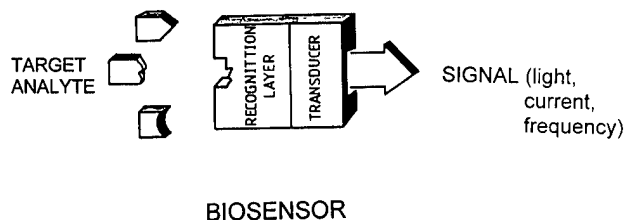

**Figure 1.** Biosensors: the intimate coupling of biorecognition and signal transduction.

presence of accelerators) have to be optimized. Chemical and thermally-induced dehybridization of the resulting duplex is often used for regenerating the interface.

Recent advances in nucleic acid recognition can enhance the power of DNA biosensors. For example, the introduction of peptide nucleic acid (PNA) has opened up exciting opportunities for DNA biosensors. PNA is a DNA mimic in which the sugar-phosphate backbone is replaced with a pseudopeptide one. The unique structural, hybridization and recognition features of solution-phase PNA (7) can be readily extrapolated onto transducer surfaces in connection with the design of highly-selective DNA biosensors. Such use of surface-confined PNA recognition layers imparts remarkable sequence specificity onto DNA biosensors (including detection of single-base mismatches) and offers other attractive advantages (including greater latitude in the selection of experimental conditions) (8).

DNA dendrimers can be used for imparting higher sensitivity onto DNA biosensors. These tree-like superstructures possess numerous single-stranded arms that can hybridize to their complementary DNA sequence. A greatly increased hybridization capacity and hence a substantially amplified response is achieved by immobilizing these dendritic nucleic acids onto the physical transducer (9).

**Optical biosensors.** Optical detection of DNA hybridization has attracted considerable attention. DNA optical biosensors commonly rely on a fiber optic to transduce the emission signal of a fluorescent label. Fiber optics are devices that carry light from one place to another by a series of internal reflections. The operation of fiber-optic DNA biosensors typically involves placement of a ssDNA probe at the end of the fiber and monitoring the fluorescent changes resulting from the association of a fluorescent compound (indicator) with the double-stranded (ds) DNA hybrid. The first DNA optical biosensor, developed by Krull and coworkers (10), relied on the use of an ethidium bromide indicator. Extremely low (femtomolar) detection limits have been achieved in connection with other fluorescent indicators (e.g. PicoGreen). Walt's group (11) developed a fiber-optic DNA sensor array for the simultaneous detection of multiple DNA sequences. Hybridization of fluorescently-labeled complementary oligonucleotides was monitored by observing the increase in fluorescence that accompanied binding. A different optical transduction, based on evanescent wave devices, can offer real-time label-free optical detection of DNA hybridization (12,13). These biosensors rely on monitoring changes in surface optical properties (shift in resonance angle due to change in the interfacial refractive

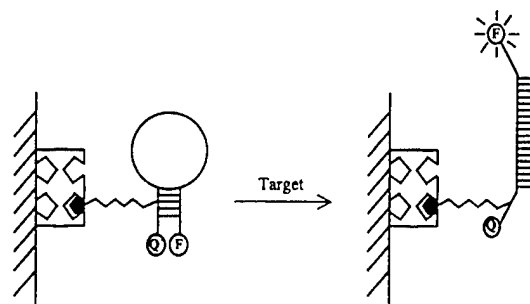

**Figure 2.** The operation of MB based optical DNA biosensors. The hybridization event induces conformational reorganization that separates the quencher from the fluorophore. [Reprinted with permission from (16). Copyright 1999 American Chemical Society.]

index) resulting from the surface binding reaction. Such devices thus combine the simplicity of surface plasmon resonance with the sensitivity of wave guiding devices. The coupling of chemiluminescence with sandwich hybridization, magnetic bead capture and flow injection operation has been used for the rapid detection of hepatitis B virus DNA (14).

*In situ*, label-free, optical detection can be achieved through changes in other optical properties. For example, a novel nanoparticle-based colorimetric detection offers great promise for direct detection of DNA hybridization (15). In this case, a distance change, accrued from the hybridization event, results in changes of the optical properties of the aggregated functional gold nanoparticles. Another new innovative approach for the direct fluorescent detection of DNA hybridization relies on the use of molecular beacons (MBs) (16). MBs are oligonucleotides with a stem-and-loop structure, labeled with a fluorophore and a quencher on the two ends of the stem, that become fluorescent upon hybridization (Fig. 2). In addition to their direct monitoring capability, MB probes offer high sensitivity and specificity.

**Electrochemical biosensors.** Electrochemical devices have also proven very useful for sequence-specific biosensing of DNA (17,18). The inherent miniaturization of such devices and their compatibility with advanced microfabrication technology make them excellent candidates for DNA diagnostics. Electrochemical detection of DNA hybridization usually involves monitoring a current response under controlled potential conditions (in a manner analogous to most hand-held meters used by sufferers of diabetes for measuring their blood glucose level). The hybridization event is commonly detected via the increased current signal of a redox indicator (that recognizes the DNA duplex) or from other hybridization-induced changes in electrochemical parameters (e.g. conductivity or capacitance). Mikkelsen's team, that pioneered the use of redox indicators, demonstrated its utility for detecting the cystic fibrosis  $\Delta F508$  deletion sequence associated with 70% of cystic fibrosis patients (19). A detection limit of 1.8 fmol was demonstrated for the 4000-base DNA fragment in connection to a  $\text{Co}(\text{bpy})_3^{3+}$  indicator. High selectivity towards the disease sequence (but not to the normal DNA) was achieved by performing the hybridization at an elevated ( $43^\circ\text{C}$ ) temperature.

Such use of the electrochemical transduction mode requires that proper attention be given to the choice of the indicator and its detection scheme. New redox indicators, offering greater discrimination between ss and dsDNA are being developed for attaining higher sensitivity. The use of a threading intercalator ferrocenyl naphthalene diimide (20) that binds to the DNA hybrid more tightly than usual intercalators and displays small affinity to the single-stranded probe has been very successful.

The use of enzyme labels also offers great promise for electrochemical detection of DNA hybridization. Heller's group (21) demonstrated that a direct amperometric monitoring of the hybridization event can be achieved in connection to the use of horseradish-peroxidase labeled target. In this system, the hybridization event resulted in the 'wiring' of the enzyme to the transducer (via an electron-conducting redox hydrogel), hence leading in a continuous hydrogen-peroxide electro-reduction current. Willner's group (22) illustrated that multiple amplifications can be achieved by coupling of a peroxidase enzyme label with the surface accumulation of the phenol reaction product.

Increased attention has been given recently to new label-free electrochemical detection schemes which offer faster and simpler assays. For example, it is possible to exploit changes in the intrinsic electroactivity of DNA (e.g. the guanine oxidation peak) accrued from the hybridization event (23,24). To overcome the limitations of the probe sequences (absence of G), guanines in the probe sequence were substituted by inosine residues (pairing with Cs) and the hybridization was detected through the target DNA guanine signal (23). A greatly amplified guanine signal, and hence hybridization response, was obtained by using the  $\text{Ru}(\text{bpy})_3^{2+}$  redox mediator (24). Direct, label-free, electrical detection of DNA hybridization has also been accomplished by monitoring changes in the conductivity of conducting polymer molecular interfaces, e.g. DNA-modified polypyrrole films (25,26). Eventually, it would be possible to eliminate these polymeric interfaces and to exploit different rates of electron-transfer through ss and dsDNA for probing hybridization (including mutation detection via the perturbation in charge transfer through DNA). Recent activity in this direction is encouraging (27).

The electrochemical response of the G nucleobase is also very sensitive to the DNA structure and can thus be used for probing DNA damage or interactions. Changes in the guanine oxidation, and of other intrinsic DNA redox signals, have thus been used for detecting chemical and physical damage (4,28).

**Mass-sensitive devices.** Another useful indicator-free detection scheme relies on the use of quartz crystal microbalance (QCM) transducers. The QCM is an extremely sensitive mass-measuring device, that allows dynamic monitoring of hybridization events (29). QCM hybridization biosensors consist of an oscillating crystal with the DNA probe immobilized on its surface. The increased mass, associated with the hybridization reaction, results in a decrease of the oscillating frequency. This is illustrated in Figure 3 (30) where the high sensitivity of QCM transducers was coupled with the remarkable specificity of PNA probes towards the detection of a single-base alteration in the *p53* gene. A highly-sensitive microgravimetric device was also developed for detecting the Tay-Sachs genetic disorder (31). QCM transducers have been used for investigating other DNA interactions, including real-time detection of protein-DNA

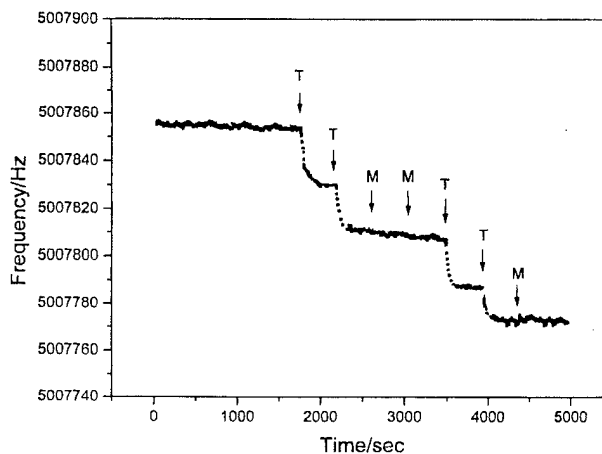

**Figure 3.** Frequency-time response of a PNA/QCM to additions of the target (T) and mismatch (M) oligonucleotides. The hybridization event results in decreased frequency, reflecting the increased mass of the crystal. [Reprinted with permission from (30). Copyright 1997 American Chemical Society.]

binding (32) or monitoring of enzymatic cleavage reactions (33). Analogous acoustic wave devices were developed for monitoring the binding of anticancer drugs to DNA (34).

## DNA MICROARRAYS

The analysis of complex DNA samples and acquisition of sequence and expression information would require the integration of multiple biosensors in connection with DNA microarrays (35,36). A number of terms, like DNA arrays, gene chips or biochips, are often being intermixed to describe these devices. The most attractive features of these devices are the miniaturization, speed and accuracy. Accordingly, this DNA microchip technology offers an enormous potential for rapid multiplex analysis of nucleic acid samples, including the diagnosis of genetic diseases, detection of infectious agents, measurements of differential gene expression, drug screening or forensic analysis (35,36). Such use of DNA microarrays is thus revolutionizing many aspects of genetic analysis.

Such hybridization chips are fabricated from glass, silicon or plastic supports, and comprise thousands of 10–100  $\mu\text{m}$  reaction zones onto which individual oligonucleotides have been deposited. This results in high densities (up to  $10^6$  sites/ $\text{cm}^2$ ) in connection with typical 1–2  $\text{cm}^2$ -size chips. The exact number of probes varies in accordance with the application. The actual construction of gene chips involves the immobilization or synthesis of an array of DNA probes on a solid support. High-density DNA arrays often require the use of physical delivery (e.g. microjet deposition technology), involving the dispensation of picoliter volumes onto discrete locations on the chip. It is essential to activate the surface for a covalent attachment of the oligonucleotide probes.

Successful implementation of DNA chip technology requires development of methods for fabricating the probe arrays, detecting the target hybridization, algorithms for analyzing the data, and reconstructing the target sequence. Such array technology thus integrates molecular biology,

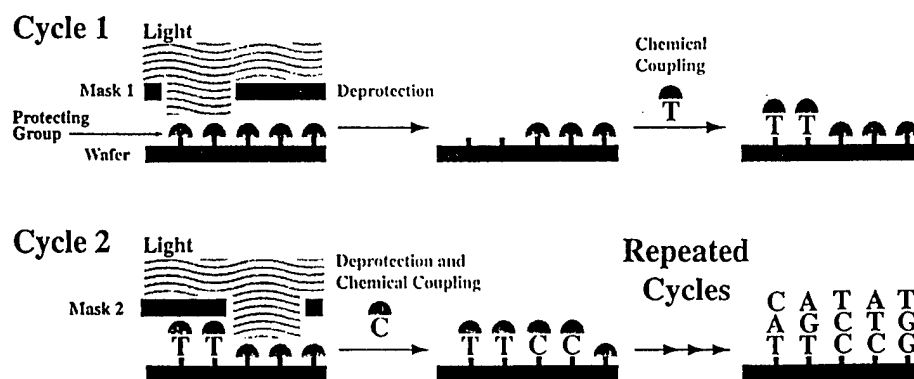

**Figure 4.** The light directed probe array synthesis process used for the preparation of Affymetrix's GeneChip.

advanced microfabrication/micromachining technologies, surface chemistry, analytical chemistry, software, robotics and automation; i.e. a truly interdisciplinary field. The automation of gene chip systems greatly facilitates their production and accelerates their operation, while eliminating human errors (accrued from the sample handling). The detection of the DNA hybridization (at the individual spots) relies on the signal generated by the binding event. Unlike individual biosensors (described earlier), scanning or imaging the chip surface is essential for obtaining the complete hybridization pattern. Fluorescence imaging and mass spectroscopy are commonly used for such 'reading' of the chips. The former usually relies on confocal laser scanning. Bioinformatics tools are used to relate the complexity of the data into useful information. In the following sections, selected examples of DNA arrays developed by various major companies are described.

The GeneChip system of the array pioneer, Affymetrix (Santa Clara, CA), provides the sequence information by hybridization with a set of target DNA fragments prepared from one or more genes of interest (37,38). The system consists of four integrated parts: a disposable DNA probe array, a fluidic station for introducing the test sample, a scanner to read the data, and software to control the instrument and process the data. The probe array consists of an assembly of oligonucleotides of known sequence in a site-specific arrangement on a silicon surface. A photolithographic-combinatorial chemistry strategy is used to synthesize large numbers of DNA probes in specific locations on a chip (Fig. 4). The fluorescence intensity data, captured from the scanner, are used with computer files (containing the sequences and location of all the probes) to provide the DNA profiling of the test sample. Affymetrix's DNA microarray chip technology is rapidly moving out from the feasibility phase into the application phase. The company has a number of GeneChips for screening for breast cancer, for detecting mutations in the HIV genome and in the *p53* tumor-suppressor gene, or for identifying bacterial pathogens.

Hyseq Inc. (Sunnyvale, CA) is collaborating with Perkin-Elmer in designing a universal microarray DNA 'Superchip' system that facilitates sequencing by hybridization (SBH). In the Hychip system, capture probes on the chip surface hybridize to target DNA and are covalently bound to the

labeled probes that also hybridize to the target DNA in an adjacent position. A fluorescence spot indicates the side-by-side binding of the unknown DNA with the probe and tagged probe. The process is repeated with another labeled probe and dedicated software figures out what the DNA sequence must be. The same chip can be used for detecting point mutations related to genetic diseases, cancer or infectious diseases.

Clinical Micro Sensors (Pasadena, CA) is developing a small, battery-operated instrument, based on electrochemical detection of DNA hybridization, for meeting the needs of point-of-care diagnosis. This electrochemical route is ideal for shrinking the hardware (compared to that used for generating fluorescence hybridization patterns). The company, that recently formed an alliance with Motorola, relies on DNA-label complexes that are connected to the electrode by phenylacetylene 'molecular wires' embedded in a self-assembled monolayer of alkane thiols. The layer also protects the surface, hence facilitating the analysis of complex biological samples.

DNA microarrays offer great promise for monitoring gene expression in humans. Technology developed by Brown and co-workers uses RNA expression in biochips to identify differential gene expression relevant to different biological states (39). The gene-expression arrays of Incyte Pharmaceuticals Inc. (Palo Alto, CA) are based on fluorescent-labeled probes and competitive hybridization; the differential gene expression is being measured through competitive hybridization of two mRNA sets isolated from normal and diseased samples, and labeled with different-colored fluorescent tags. Scanning for the two colors and using dedicated expression analysis software allow researchers to quantify expression changes in healthy versus diseased samples. An ink-jet printing technology is used for localizing the (500–5000 bp long) probes on a glass substrate. The Atlas™ microarrays of Clontech Inc. (Palo Alto, CA) also provide sensitive detection of gene expression in connection to fluorescent dyes and glass or Nylon substrates.

#### 'LAB-ON-A-CHIP'

Another active field is the integration of the sample preparation and DNA array detection in the so-called 'Lab-on-a-Chip' configuration (40,41). The goal of this technology is to fully

integrate multiple processes, including sample collection and pretreatment with the DNA extraction, amplification, hybridization and detection, on a microfluidic platform. The ability to perform all the steps of the biological assay on a single self-contained microchip promises significant advantages in terms of speed, cost, sample/reagent consumption, contamination, efficiency and automation (including parallel sample processing). Such miniaturization of the analytical instrumentation will enable transportation of the laboratory to the sample source (as desired for point-of-care testing). The preparation of these credit-card sized microlaboratories commonly relies on advanced microfabrication and micromachining technologies, using processes common in the manufacture of electronic circuitry. Sophisticated devices have thus been fabricated with pumps, valves, heaters, filters, along with the corresponding fluidic network. On-chip fluid manipulations have been demonstrated for sequentially transporting nanoliter samples through a network of microchannels, mixing of sample and reagents, dispensing of samples, DNA restriction digestion and electrically-driven separations (42).

A variety of microstructures have been proposed for on-chip PCR amplification (43,44). For example, PCR amplification has been performed by continuously flowing the sample through three well-defined temperature controlled zones on a glass microchip (43). The pattern of the chip layout determined the relative time a fluid element is exposed to each temperature zone. An array of PCR microchips, based on multiple reaction chambers with resistive heaters was developed at the Lawrence Livermore National Laboratory (44). A microchip device for cell lysis, multiplex PCR and electrophoretic sizing has also been described (Fig. 5; 42). Voltages, applied through electrodes placed within the individual reservoirs (circles in Fig. 5), are used to drive the electroosmotic flow. Such electroosmotic 'pumping' obviates the need for mechanical pumps or valves, with the channel intersections serving as 'virtual injection valves'.

Nanogen Inc. (San Diego, CA) has developed an electronic sample preparation process. The company is addressing each step in the sample-to-result process on microfabricated chip-based devices (45). This includes the integration of electronic cell separation, electronic sample transport, electronically-accelerated hybridization and electronic denaturation. Controlled electric fields have been used for discriminating among oligonucleotide hybrids with varying binding strengths (including between complete match and single-base mismatch) and to expel the unhybridized DNA. Such fine-tuned electronic stringency selection obviates the need for extensive washing. The electronically-regulated sample preparation process was demonstrated for the dielectrophoretic separation of *Escherichia coli* from blood cells (46). After the isolation, the bacteria were lysed by a series of high-voltage pulses. A variety of microelectronic chips including 25, 100, 400, 1600 and 10 000 addressable test sites have been fabricated by Nanogen Inc. The 10 000 test site chip is being developed for drug discovery applications.

Microfabricated devices are also attractive for high-throughput electrically-driven DNA separations. For example, Woolley *et al.* (47) described capillary electrophoresis microchips that allow DNA sizing of 12 samples in parallel with a resolution of 10 bp and higher throughputs than conventional

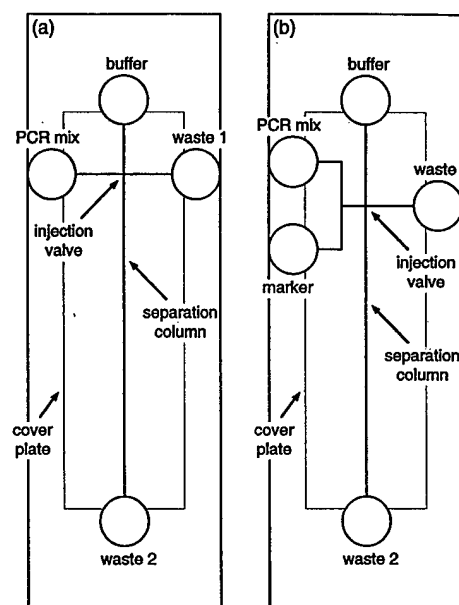

**Figure 5.** Schematic of microchips used for cell lysis, PCR amplification and electrophoretic analysis (a), and for sizing of PCR products with a marker (b). [Reprinted with permission from (42). Copyright 1998 American Chemical Society.]

techniques. The first commercially available product based on microfluidic technology is the HP 2100 Bioanalyzer (Hewlett Packard). This instrument integrates the sample handling and electrophoretic separation. The disposable LabChip™ has multiple interconnected reservoirs for samples, sizing ladder, sieving matrix and buffers. Assays are available for analyzing restriction digestions with DNA fragments 100–12 000 bases long, and for determining size and concentration information for DNA fragments 100–7500 bases long.

## CONCLUSIONS

Over the past decade we have witnessed intense activity aimed at developing DNA biosensors and gene chips. Such devices offer considerable promise for obtaining the sequence-specific information in a faster, simpler and cheaper manner compared to traditional hybridization assays. These DNA microarray and biosensor technologies are rapidly advancing and applications ranging from genetic testing to gene expression and drug discovery have been demonstrated. Further scaling down, particularly of the support instrumentation, should lead to hand-held DNA analyzers. Innovative efforts, coupling fundamental biological and chemical sciences with technological advances in the fields of micromachining and microfabrication should lead to even more powerful devices that will accelerate the realization of large-scale genetic testing. A wide range of new gene chips and DNA biosensors are thus expected to reach the market in the coming years. While offering remarkable tools for genetic analysis, proper applications of these new devices would still require a solid intellectual input.

## ACKNOWLEDGEMENTS

DNA work in the author's laboratory is funded by NIH (grant RR 14549-01) and by the US Army Medical Research.

## REFERENCES

- Taylor,R.F. and Schultz,J.S. (1996) *Handbook of Chemical and Biological Sensors*. Institute of Physics Publishing, Bristol, UK.
- Christopoulos,T.K. (1999) *Anal. Chem.*, **71**, 425R-438R.
- Zhai,J., Hong,C. and Yang,R. (1997) *Biotechnol. Adv.*, **15**, 43-58.
- Palecek,E., Fojta,M., Tomschick,M. and Wang,J. (1998) *Biosens. Bioelectron.*, **13**, 621-628.
- Herne,T. and Tarlov,M.J. (1997) *J. Am. Chem. Soc.*, **119**, 8916-8920.
- Piunno,P.A., Watterson,J., Wust,C. and Krull,U. (1999) *Anal. Chim. Acta.*, **400**, 73-89.
- Nielsen,P. (1999) *Acc. Chem. Res.*, **32**, 624-630.
- Wang,J., Palecek,E., Nielsen,P., Rivas,G., Cai,X., Shiraiishi,H., Dontha,N., Luo,D. and Farias,P. (1996) *J. Am. Chem. Soc.*, **118**, 7667-7671.
- Wang,J., Jiang,M., Nilsen,T. and Getts,R. (1998) *J. Am. Chem. Soc.*, **120**, 8281-8282.
- Piunno,P., Krull,U., Hudson,R., Damha,M. and Cohen,H. (1995) *Anal. Chem.*, **67**, 2635-2643.
- Ferguson,J.A., Boles,T., Adams,C. and Walt,D. (1996) *Nat. Biotechnol.*, **14**, 1681-1684.
- Watts,H., Yeung,D. and Parkes,H. (1995) *Anal. Chem.*, **67**, 4283-4289.
- Thiel,A., Frutos,A., Jordan,C., Corn,R. and Smith,L. (1997) *Anal. Chem.*, **69**, 4984-4956.
- Chen,X., Zhang,X., Chai,Y., Hu,W., Zhang,Z., Zhang,X. and Cass,A.E. (1998) *Biosens. Bioelectron.*, **13**, 451-458.
- Storhoff,J., Elghanian,R., Mucic,C., Mirkin,C. and Letsinger,R. (1998) *J. Am. Chem. Soc.*, **120**, 1959-1964.
- Fang,X., Liu,X., Schuster,S. and Tan,W. (1999) *J. Am. Chem. Soc.*, **121**, 2921-2922.
- Mikkelsen,S.R. (1996) *Electroanalysis*, **8**, 15-19.
- Wang,J. (1999) *Chem. Eur. J.*, **5**, 1681-1685.
- Millan,K.M., Saraulo,A. and Mikkelsen,S.R. (1994) *Anal. Chem.*, **66**, 2943-2948.
- Takenaka,S., Uto,Y., Saita,H., Yokoyama,M., Kondo,H. and Wilson,D. (1998) *Chem. Commun.*, 1111-1112.
- de Lumley,T., Campbell,C. and Heller,A. (1996) *J. Am. Chem. Soc.*, **118**, 5504-5508.
- Patolsky,F., Katz,E., Bardea,A. and Willner,I. (1999) *Langmuir*, **15**, 3703.
- Wang,J., Rivas,G., Fernandes,J., Paz,J.L., Jiang,M. and Waymire,R. (1998) *Anal. Chim. Acta.*, **375**, 197-203.
- Johnston,D.H., Glasgow,K. and Thorp,H.H. (1995) *J. Am. Chem. Soc.*, **117**, 8933-8938.
- Korri-Youssoufi,H., Garnier,F., Srivtava,P., Godillot,P. and Yassar,A. (1997) *J. Am. Chem. Soc.*, **119**, 7388-7391.
- Wang,J., Jiang,M., Fortes,A. and Mukherjee,B. (1999) *Anal. Chim. Acta.*, **402**, 7-12.
- Holmlim,R.E., Dandliker,P.J. and Barton,J.K. (1997) *Angew Chem. Int. Ed. Engl.*, **36**, 2714-2718.
- Wang,J., Rivas,G., Ozsoz,M., Grant,D., Cai,X. and Parrado,C. (1997) *Anal. Chem.*, **69**, 1457-1460.
- Okahata,Y., Matsunobo,Y., Ijio,K., Murakami,A. and Makino,M. (1992) *J. Am. Chem. Soc.*, **114**, 8299-8300.
- Wang,J., Nielsen,P.E., Jiang,M., Cai,X., Fernandes,J., Grant,D., Ozsoz,M., Beglieter,A. and Mowat,M. (1997) *Anal. Chem.*, **69**, 5200-5202.
- Bardea,A., Dagan,A., Ben-Dov,I., Amit,B. and Willner,I. (1998) *Chem. Commun.*, 839-841.
- Nikura,K., Nagata,Y. and Okahata,Y. (1996) *Chem. Lett.*, 863-866.
- Wang,J., Jian,M. and Palecek,E. (1999) *Bioelectrochem. Bioenerg.*, **48**, 477-480.
- Su,H., Williams,P. and Thompson,M. (1995) *Anal. Chem.*, **67**, 1010-1016.
- Service,R. (1998) *Science*, **282**, 396-399.
- Ramsey,G. (1998) *Nat. Biotechnol.*, **16**, 40-45.
- Gette,W. and Kreiner,T. (1997) *Am. Lab.*, March issue, 15-17.
- Lipshutz,R., Morris,D., Chee,M., Hubbell,E., Kozal,M., Shah,N., Shen,N., Yang,R. and Fodor,S. (1995) *Biotechnology*, **19**, 442-445.
- Iyer,V., DeRisi,J., Eisen,M., Ross,D., Spellman,P., Hudson,J., Schuler,G., Lashkari,D., Shalon,D., Botstein,D. and Brown,P. (1997) *FASEB J.*, **11**, 1571.
- Burke,D.T., Burns,M.A. and Mastrangelo,C. (1997) *Genome Res.*, **7**, 189-197.
- Harrison,D.J., Fluri,K., Seiler,K., Fan,Z., Effenhauser,C. and Manz,A. (1993) *Science*, **261**, 895-997.
- Waters,L.C., Jacobson,S., Kroutchinina,N., Khandurina,J., Foote,R. and Ramsey,J.M. (1998) *Anal. Chem.*, **70**, 158-162.
- Kopp,M.U., de Mello,A. and Manz,A. (1998) *Science*, **280**, 1046-1050.
- Woolley,A.T., Hadley,D., Landre,P., de Mello,A., Mathies,R.A. and Northrup,M.A. (1996) *Anal. Chem.*, **68**, 4081-4086.
- Sosnoweki,R.G., Tu,E., Butler,W., O'Connell,J. and Heller,M.J. (1997) *Proc. Natl Acad. Sci. USA*, **94**, 1119-1123.
- Cheng,J., Sheldon,E., Wu,L., Gerrue,L., Carrino,J., Heller,M. and O'Connell,J. (1998) *Nat. Biotechnol.*, **16**, 541-545.
- Woolley,A.T., Senasbaugh,G. and Mathies,R. (1997) *Anal. Chem.*, **69**, 2181-2186.

## GENOMAGNETIC ELECTROCHEMICAL ASSAYS OF DNA HYBRIDIZATION

Joseph Wang\*, Danke Xu, Arzum Erdem,<sup>1</sup> Ronen Polsky, and Marcos A.  
Salazar

Department of Chemistry and Biochemistry

New Mexico State University

Las Cruces, NM 88003, U.S.A.

\*Corresponding author. Fax: 1-505-646-2649. e-mail: [joewang@nmsu.edu](mailto:joewang@nmsu.edu)

<sup>1</sup> On leave from Ege University, Faculty of Pharmacy, 35100, Bornova-Izmir, Turkey.

## ABSTRACT

An electrochemical genomagnetic hybridization assay has been developed to take advantage of a new and efficient magnetic separation/mixing process, the amplification feature of enzyme labels, and single-use thick-film carbon transducers operated in the pulse-voltammetric mode. It represents the first example of coupling a magnetic isolation with electrochemical detection of DNA hybridization. The new protocol employs an enzyme-linked sandwich solution hybridization, with a magnetic-particle labeled probe hybridizing to a biotinylated DNA target that captures a streptavidin-alkaline phosphatase. The  $\alpha$ -naphthol product of the enzymatic reaction is quantitated through its well-defined, low-potential (+0.1V vs. Ag/AgCl) differential pulse voltammetric peak at the disposable screen-printed electrode. The efficient magnetic isolation is particularly attractive for electrical detection of DNA hybridization which is commonly affected by the presence of nonhybridized nucleic acid adsorbates. The new biomagnetic processing combines such magnetic separation with a low-volume magnetic mixing, and allows simultaneous handling of 12 samples. The attractive bioanalytical behavior of the new enzyme-linked genomagnetic electrical assay is illustrated for the detection of DNA segments related to the breast-cancer BRCA1 gene.

**Keywords:** DNA assay, Electrochemistry, Magnetic separation, Enzyme label.

Ref-6

**METAL NANOPARTICLE BASED ELECTROCHEMICAL  
STRIPPING POTENTIOMETRIC DETECTION OF DNA  
HYBRIDIZATION**

Joseph Wang\*, Danke Xu, Abdel-Nasser Kawde, and Ronen Polsky

Department of Chemistry and Biochemistry  
New Mexico State University  
Las Cruces, New Mexico 88003

\*Corresponding author

## ABSTRACT

A new nanoparticle-based electrical detection of DNA hybridization, based on electrochemical stripping detection of the colloidal gold tag, is described. In this protocol the hybridization of a target oligonucleotide to magnetic-bead linked oligonucleotide probes is followed by binding of the streptavidin-coated metal nanoparticles to the captured DNA, dissolution of the nanometer-sized gold tag, and potentiometric stripping measurements of the dissolved metal tag at single-use thick-film carbon electrodes. An advanced magnetic processing technique is used to isolate the DNA duplex and to provide low-volume mixing. The influence of relevant experimental variables, including the amounts of the gold nanoparticles and the magnetic beads, the duration of the hybridization- and gold dissolution steps, and parameters of the potentiometric stripping operation upon the hybridization signal is examined and optimized. Transmission Electron Microscopy (TEM) micrographs indicate a three-dimensional network structure, consisting of magnetic beads linked together through hybridized DNA strands and 5-nm gold particles. The new electrochemical stripping metallogenomagnetic protocol couples the inherent signal amplification of stripping metal analysis, with discrimination against nonhybridized DNA, the use of microliter sample volumes and disposable transducers, and hence offers great promise for decentralized genetic testing.

# SILVER-ENHANCED COLLOIDAL GOLD ELECTROCHEMICAL STRIPPING DETECTION OF DNA HYBRIDIZATION

Joseph Wang,\* Ronen Polsky and Danke Xu

Department of Chemistry and Biochemistry, New Mexico State University, Las Cruces, New Mexico 88003

\*Corresponding author; e-mail: [joewang@nmsu.edu](mailto:joewang@nmsu.edu)

RECEIVED DATE (will be automatically inserted after manuscript is accepted).

Nanoparticle-based materials offer excellent prospects for chemical and biological sensing because of their unique optical and mechanical properties<sup>1</sup>. Silver deposition on gold nanoparticles is commonly used in histochemical microscopy to visualize DNA-conjugated gold particles. Mirkin and co-workers have developed DNA sensors using hybridization-induced changes in (distance-dependent) optical properties of gold-particle modified oligonucleotides,<sup>2</sup> and a scanometric DNA array based on silver amplification of a hybridization event.<sup>3</sup> Silver enhancement was also used for detecting single viral copies using in situ hybridization, providing an alternative for in-situ polymerase chain reaction.<sup>4</sup> Inspired by such novel use of gold nanoparticle labeling and subsequent silver enhancement, the present communication aims at developing an analogous electrical route for gene detection. In particular, we wish to demonstrate the detection of DNA hybridization in connection to measurement of the deposited silver by the extremely sensitive technique of electrochemical stripping metal analysis.<sup>5</sup> While the new silver-enhanced colloidal gold stripping detection strategy is presented below in connection to DNA hybridization, it represents an attractive alternative to histochemical imaging of protein- and antibody-conjugated nanoparticles.

Figure 1 outlines the steps of the new particle-based bioelectronic protocol. A streptavidin-coated magnetic latex sphere (A) is bound to a biotinylated DNA probe (B). The hybridization event between the target nucleic acid and the captured probe (C), is followed by binding of streptavidin-coated 20nm colloidal gold to the biotinylated target (D), and 10 min of catalytic silver precipitation onto the gold nanoparticles (E). The silver is then dissolved, and detected at a disposable thick-film carbon electrode (F) using a potentiometric stripping protocol.

The new protocol thus couples the inherent signal amplifications of nanoparticle-promoted silver precipitation and of stripping metal analysis, with effective discrimination against nonhybridized DNA, the use of microliter sample volumes and single-use transducers, and hence offers great promise for decentralized genetic testing. Its attractive performance has been illustrated for the detection of DNA segments related to the BRCA1 breast cancer gene. Figure 2A

1. a. Templeton, A.; Wuelfing, W.P.; Murray, R.W. *Acc. Chem. Res.* **2000**, *33*, 27; b. Liu, J.; Alvarez, J.; Kaifer, A. *Adv. Mater.* **2000**, *12*, 1381; c. Dubertret, B.; Calame, M.; Libchaber, A.J. *Nature Biotechnol.* **2001**, *19*, 365.

2. Storhoff J.J.; Elghanian R.; Mucic R.C.; Mirkin C.A.; Letsinger R.L. *J. Am. Chem. Soc.*, **1998**, *120*, 1959.

3. Taton T.A.; Mirkin A.A.; Letsinger R.L. *Science*, **2000**, *289*, 1757.

4. Zehbe I.; Hacker G.W.; Su H.C.; Hauser-Kronberger C.; Hainfeld J.F.; Tubbs R. *American J. Pathology*, **1997**, *150*, 1553.

5. Wang, J. *Analytical Electrochemistry (2nd edition)*, Wiley, New York, **2000**

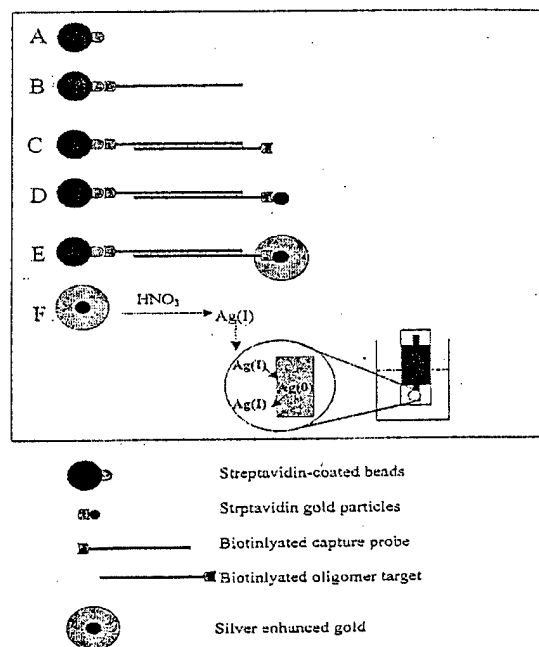

**Figure 1.** Schematic representation of the analytical procedure. (A) Introduction of the streptavidin-coated beads; (B) addition and capture of the biotinylated probe; (C) addition of the biotinylated target and the hybridization event; (D) addition of the streptavidin-gold particles; (E) addition of the silver enhancer and formation of metallic silver tag; (F) dissolution of the silver tag and its stripping potentiometric detection.

shows the stripping response of the gold tag, from a sample containing 200ng/mL (1.6 pmol) nucleic-acid target (using 1M HBr/0.1mM Br<sub>2</sub> as the dissolution and detection solutions),<sup>6</sup> while Figure 2B shows the corresponding silver hybridization stripping response after silver enhancement, dissolution, and deposition (in the 'Silver-Enhancer Solution', a 50% HNO<sub>3</sub> medium, and 0.1M HNO<sub>3</sub>/0.1M KNO<sub>3</sub> electrolyte, respectively). The well-defined silver signal ( $E_p=0.23V$ ) is 125 times greater than that of the gold tag (1580ms vs 12.5ms; note the different scales). Substantially smaller signals are observed for a 50-fold excess (10 $\mu$ g/mL) of non-complementary DNA, and for a 3-fold excess of the three-base mismatched oligomer (Fig. 1C and D, respectively). Such minimization of non-specific binding is attributed to the efficient magnetic separation, i.e., removal of nonhybridized DNA. The mixture response of Fig. 2E also reflects the discrimination against excess of unwanted constituents. Also shown (Figure 2F) is the signal for a 5ng/mL breast cancer DNA target, which indicates a low detection limit of around 0.2ng/mL (32pM). This corresponds to 10pg (1.5fmol) in the 50  $\mu$ L hybridization solution (in connection to a 20 min hybridization). Substantially lower detection limits are expected in connection to longer hybridization periods and/or deposition times. The electrochemical route offers a well-defined concentration dependence. A calibration experiment over the 20-1000ng/mL range resulted in a linear response (with a slope of 3.28ms.mL/ng). Most favorable stripping

6. Dequaire M.; Degrand C.; Limoges B. *Anal. Chem.*, **2000**, *72*, 5521.

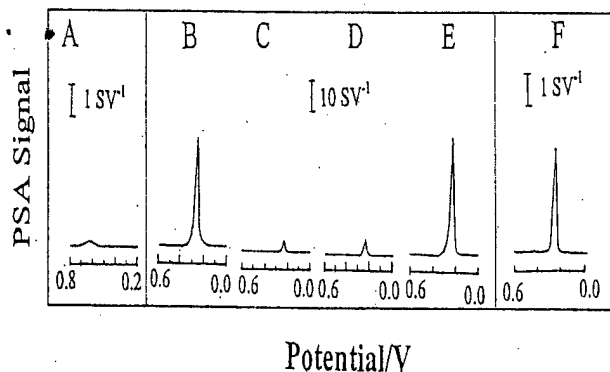

**Figure 2.** Chronopotentiometric stripping response for DNA detected by monitoring the gold nanoparticle tag (A) and the silver enhancer tag (B-F): 200ng/mL target (A); 200ng/mL target (B); 10 $\mu$ g/mL noncomplementary strand (C); 600ng/mL three-base mismatched strand (D); a mixture of 200ng/mL target and 10 $\mu$ g/mL noncomplementary strand (E); and 5ng/mL target (F).

detection of the dissolved silver tag was obtained using deposition at  $-0.5$  V and a stripping current of  $3\mu$ A. The peak area increased linearly with the deposition time over the 0.5-10 min range, with 10 min deposition yielding ca. 83-fold enhancement of the response (vs. that without accumulation).

The ultimate objective of the silver enhancement is to cause catalytic deposition of silver (on the gold tags), while avoiding spontaneous deposition onto other components of the system. Because analogous optical methods rely on a threshold amount of silver for visualization, excess silver ions is not of major concern. In contrast, an excess of silver can affect the reliability of the stripping-based electrical detection. It has been shown that the polyanionic DNA backbone itself can act as a nucleation site for silver growth through cation exchange with sodium and ion-pair complexation to the DNA bases.<sup>7</sup> Such adsorption of silver ions on the captured probe can lead to undesired background contributions. These 'blank' signals can be eliminated by adding a sodium thiosulfate fixer solution (that transfers the silver cation into the  $\text{Ag}(\text{S}_2\text{O}_3)_2^-$  anion),<sup>8</sup> and by controlling the silver precipitation time. Precipitation periods shorter than 11 min assured that only the Au particle tags are coated with silver, with a 10 min period offering the best tradeoff between high sensitivity and selectivity.

Such initial silver nucleation onto the Au tags leads to a continuous deposition of silver on silver, and eventually to coverage of the entire structure. A transmission electron micrograph before the silver enhancement showed a three-

7. Braun E.; Eichen Y.; Sivan U.; Ben-Yoseph G. *Nature*, 1998, 391, 775.

8. Henn R.W., *Neblett's Handbook of Photography and Repography Materials, Processes and Systems*, 1977, Litton Educational Publishing Inc., p. 114.

dimensional aggregate of the magnetic spheres (linked through the DNA hybrids and Au nanoparticles). In silver enhancement. Dissolution of this precipitate results in a high silver level, e.g., 13 $\mu$ g/mL, as was indicated from comparison of the stripping response for a standard 100ng/mL silver solution and for the silver precipitated in connection to the hybridization of 5ng/mL contrast, a non-uniform distribution of deposited silver, covering the entire aggregate, was

In conclusion, we described a novel electrochemical method for detecting DNA hybridization based on the precipitation of silver onto gold nanoparticle tags. The dramatic signal amplification advantage of the silver-enhanced colloidal gold stripping detection has been combined with an efficient magnetic removal of non-complementary DNA. The new method represents an attractive addition to the arsenal of electrochemical strategies for DNA analysis,<sup>9,10</sup> and offers great promise for gene detection, in general. Autometallographic studies (e.g., of immunological reactions) should also benefit from the attractive performance, simplicity, and portability of the new approach. The creation of DNA arrays, yielding multiple silver stripping peaks (corresponding to the individual sites) can be envisioned.

9. Palecek, E.; Fojta, M. *Anal. Chem.* 2001, 73, 75A.

10. Wang, J. *Chem. Eur. J.* 1999, 5, 1681

#### ACKNOWLEDGMENT:

Financial support from the US Army Medical Research (Award No. DAMD17-00-1-0366) and the National Institutes of Health (Grant No. R01 14549-02) is gratefully acknowledged.