

REPORT DOCUMENTATION PAGE

Form Approved
OMB NO. 0704-0188

Public Reporting burden for this collection of information is estimated to average 1 hour per response, including the time for reviewing instructions, searching existing data sources, gathering and maintaining the data needed, and completing and reviewing the collection of information. Send comment regarding this burden estimates or any other aspect of this collection of information, including suggestions for reducing this burden, to Washington Headquarters Services, Directorate for Information Operations and Reports, 1215 Jefferson Davis Highway, Suite 1204, Arlington, VA 22202-4302, and to the Office of Management and Budget, Paperwork Reduction Project (0704-0188,) Washington, DC 20503.

1. AGENCY USE ONLY (Leave Blank)		2. REPORT DATE 30 Jun 01	3. REPORT TYPE AND DATES COVERED Final Report - 1 Dec 00 - 30 Jun 01 01 May 00 - 01 Jan 01	
4. TITLE AND SUBTITLE Helicopter Rotor Antenna			5. FUNDING NUMBERS MIPR OMNACAR063 ARO MIPR	
6. AUTHOR(S) Dr. Ronald J. Pogorzelski and Dr. Vaughn P. Cable				
7. PERFORMING ORGANIZATION NAME(S) AND ADDRESS(ES) Jet Propulsion Laboratory, California Institute of Technology 4800 Oak Grove Drive Pasadena, CA 91109-8099			8. PERFORMING ORGANIZATION REPORT NUMBER 3365-01-FPR1 [JPL Task Plan 80-5238]	
9. SPONSORING / MONITORING AGENCY NAME(S) AND ADDRESS(ES) U. S. Army Research Office P.O. Box 12211 Research Triangle Park, NC 27709-2211			10. SPONSORING / MONITORING AGENCY REPORT NUMBER 40420-EL 40420.1-EL	
11. SUPPLEMENTARY NOTES The views, opinions and/or findings contained in this report are those of the author(s) and should not be construed as an official Department of the Army position, policy or decision, unless so designated by other documentation.				
12 a. DISTRIBUTION / AVAILABILITY STATEMENT Approved for public release; distribution unlimited.			12 b. DISTRIBUTION CODE	
13. ABSTRACT (Maximum 200 words) This effort was directed toward demonstration of the efficacy of a concept for mitigation of the rotor blade modulation problem in helicopter communications. An antenna is envisioned with radiating elements mounted on the rotor and rotating with it. The rf signals are coupled to the radio stationary with respect to the airframe via a coupler of unique design. The coupler has an rf cavity within which a mode is established and the field distribution of this mode is sampled by probes rotating with the radiating elements. In this manner the radiated pattern is "despun" with respect to the rotor. Theoretical analysis has indicated that this arrangement will be less susceptible to rotor blade modulation that would be a conventional fixed mounted antenna. A small coupler operating at S-band was designed, fabricated, and mounted on a mockup representative of a helicopter body. A small electric motor was installed to rotate the rotor portion of the coupler along with a set of radiating elements during testing. This test article was evaluated using the JPL Mesa Antenna Measurement Facility to establish its ability to mitigate rotor blade modulation. It was found that indeed such a coupler will result in a despun pattern and that such a pattern can be effective in mitigation of rotor blade modulation.				
14. SUBJECT TERMS Helicopter Antenna, Rotary Joint, Rotor Blade Modulation			15. NUMBER OF PAGES 24	
			16. PRICE CODE	
17. SECURITY CLASSIFICATION OR REPORT UNCLASSIFIED	18. SECURITY CLASSIFICATION ON THIS PAGE UNCLASSIFIED	19. SECURITY CLASSIFICATION OF ABSTRACT UNCLASSIFIED	20. LIMITATION OF ABSTRACT UL	

20010731 123

MASTER COPY: PLEASE KEEP THIS "MEMORANDUM OF TRANSMITTAL" BLANK FOR REPRODUCTION PURPOSES. WHEN REPORTS ARE GENERATED UNDER THE ARO SPONSORSHIP, FORWARD A COMPLETED COPY OF THIS FORM WITH EACH REPORT SHIPMENT TO THE ARO. THIS WILL ASSURE PROPER IDENTIFICATION. NOT TO BE USED FOR INTERIM PROGRESS REPORTS: SEE PAGE 2 FOR INTERIM PROGRESS REPORT INSTRUCTIONS.

MEMORANDUM OF TRANSMITTAL

U.S. Army Research Office
ATTN: AMSRL-RO-BI (TR)
P.O. Box 12211
Research Triangle Park, NC 27709-2211

- Reprint (Orig + 2 copies)
- Technical Report (Orig + 2 copies)
- Manuscript (1 copy)
- Final Progress Report (Orig + 2 copies)
- Related Materials, Abstracts, Theses (1 copy)

CONTRACT/GRANT NUMBER: JPL Task Plan No. 80-5238, entitled "Helicopter Rotor Antenna Breadboard," NAS7-1407, Task Order 15337
REPORT TITLE: "Helicopter Rotor Antenna"

is forwarded for your information.

SUBMITTED FOR PUBLICATION TO (applicable only if report is manuscript):

Sincerely,

Carol A. Fisher
Contract Administrator
Contracts Management Office

Helicopter Rotor Antenna

Final Progress Report

Statement of the Problem

Modern military helicopters require communications capability in a number of frequency bands including HF, VHF, and UHF including both AM and FM. A major problem in providing such capability has been identifying appropriate antenna types and locations. The difficulties are due to interference both internally and externally generated, rotor blade modulation, and propagation effects in the operational environment. Antennas currently in use include blade type monopoles, towel bars, and whips and these are located in a wide variety of positions and locations on the airframe. While some perform better than others, all suffer from rotor blade and airframe effects which reduce their effectiveness. One location that has not been used to our knowledge is the main rotor itself although its attractiveness from an rf point of view has been recognized by many designers working in this arena. The main deterrent to use of the rotor has been the possible deleterious effects on the aerodynamic effectiveness of the rotor. A secondary deterrent has been the issue of conveying the rf power from the transmitter to the rotating blades. We believe that the concept proposed here deals effectively with both of these issues and may provide a flexible high performance antenna suitable for all relevant frequency bands and for both horizontal paths and satcom applications.

Objective

JPL's overall objective is to develop an antenna integrated with the main rotor of a helicopter which can facilitate communications both over linearly polarized direct line of sight horizontal links and via circularly polarized satellite link. When used for horizontal line of sight communications, the antenna is to provide angle of arrival information by virtue of its despun azimuthal modal patterns.

The specific objective of the effort reported here is the fabrication and testing of a laboratory model rotor antenna to investigate and quantify its anticipated reduced susceptibility to rotor blade modulation.

Approach

The present antenna is based on the following underlying concept. If one establishes within a cylindrically symmetric radio frequency cavity a mode of oscillation, one may sample the fields of this mode with probes connected to radiating elements and thus radiate the modal energy into free space. The fields of the cavity mode will determine the excitation of the radiating elements. If the mode excitation probes are fixed with respect to the airframe, the cavity mode fields will also be so fixed. If now these cavity

fields are coupled to radiating elements via fixed probes inserted into the cavity, clearly the radiation pattern will be fixed with respect to the airframe. However, the key feature of this concept is that if the output probes are rotated about the centerline of the cavity, the radiation pattern will remain fixed with respect to the airframe regardless of the rotation. It is expected that this fixed nature of the pattern will result in significantly reduced susceptibility to rotor blade modulation.

A test of this concept was conducted by fabricating a suitable coaxial cavity from aluminum and installing input and output probe loops. The output probes were connected to wire radiating elements and the input probes were excited through a beamforming network consisting of a 90 degree hybrid and two power dividers arranged to excite the TE_{11} mode of the coaxial structure. In addition, tests were performed in the presence of a simulated airframe consisting of aluminum plates.

Summary of Important Results

It was shown that the coupler based on the despinning concept does indeed produce a radiation pattern which is essentially fixed in both magnitude and phase with respect to the input probes. This both provides for communications and permits derivation of angle of arrival information. Comparison with a more conventional configuration consisting of a dipole beneath spinning rotor blades shows a fivefold reduction in rotor modulation effects. Similar effectiveness was demonstrated both with and without the simulated airframe. The details of the measurements and a discussion of their implications may be found in the technical report listed below.

Participating Scientific Personnel

Dr. Ronald J. Pogorzelski
Dr. Vaughn P. Cable

Technical Reports

Helicopter Rotor Antenna, JPL Task Plan No. 80-5238, June 30, 2001.



Helicopter Rotor Antenna

JPL Task Plan No. 80-5238

a research and development project for the
United States Army Research Office



Technical Report
June 30, 2001

Contact:

Dr. Ronald J. Pogorzelski, Supervisor
Spacecraft Antenna Research Group
Mail Stop 138-307
Jet Propulsion Laboratory
California Institute of Technology
4800 Oak Grove Drive
Pasadena, CA 91109-8099
(818)354-3835 FAX: (818)393-0050
pogo@jpl.nasa.gov

The work reported herein was carried out at the Jet Propulsion Laboratory, California Institute of Technology and was supported by the U. S. Army Research Office through an agreement with the National Aeronautics and Space Administration.

Table of Contents

Abstract	1
Introduction	1
Objective	1
The Concept	2
The Design of the Coupler	3
Fabrication of the Coupler and Mockup	5
Measurements	9
Discussion of Results	21
Concluding Remarks	21
Further Work <i>Partially</i> Funded by ARO	22
References	22

Helicopter Rotor Antenna

Technical Report

Abstract

This effort was directed toward demonstration of the efficacy of a concept for mitigation of the rotor blade modulation problem in helicopter communications. An antenna is envisioned with radiating elements mounted on the rotor and rotating with it. The rf signals are coupled to the radio stationary with respect to the airframe via a coupler of unique design. The coupler has an rf cavity within which a mode is established and the field distribution of this mode is sampled by probes rotating with the radiating elements. In this manner the radiated pattern is "despun" with respect to the rotor. Theoretical analysis has indicated that this arrangement will be less susceptible to rotor blade modulation than would be a conventional fixed mounted antenna. A small coupler operating at S-band was designed, fabricated, and mounted on a mockup representative of a helicopter body. A small electric motor was installed to rotate the rotor portion of the coupler along with a set of radiating elements during testing. This test article was evaluated using the JPL Mesa Antenna Measurement Facility to establish its ability to mitigate rotor blade modulation. It was found that indeed such a coupler will result in a despun pattern and that such a pattern can be effective in mitigation of rotor blade modulation.

Introduction

Modern military helicopters require communications capability in a number of frequency bands including HF, VHF, and UHF including both AM and FM. A major problem in providing such capability has been identifying appropriate antenna types and locations. The difficulties are due to interference both internally and externally generated, rotor blade modulation, and propagation effects in the operational environment. Antennas currently in use include blade type monopoles, towel bars, and whips and these are located in a wide variety of positions and locations on the airframe. While some perform better than others, all suffer from rotor blade and airframe effects which reduce their effectiveness. One location that has not been used to our knowledge is the main rotor itself although its attractiveness from an rf point of view has been recognized by many designers working in this arena. The main deterrent to use of the rotor has been the possible deleterious effects on the aerodynamic effectiveness of the rotor. A secondary deterrent has been the issue of conveying the rf power from the transmitter to the rotating blades. We believe that the concept proposed here deals effectively with both of these issues and may provide a flexible high performance antenna suitable for all relevant frequency bands and for both horizontal paths and satcom applications.

Objective

JPL's overall objective is to develop an antenna integrated with the main rotor of a helicopter which can facilitate communications both over linearly polarized direct line of sight horizontal links and via circularly polarized satellite link. When used for horizontal line of sight communications, the antenna is to provide angle of arrival information by virtue of its despun azimuthal modal patterns.

The specific objective of the effort reported here is the fabrication and testing of a laboratory model rotor antenna to investigate and quantify its anticipated reduced susceptibility to rotor blade modulation.

The Concept

Rotor blade modulation of radiation from an antenna on a helicopter can arise in two ways. First, if the antenna is placed on the fuselage, the radiation is periodically scattered by the rotor blades as they rotate through the field. See Figure 1. If, on the other hand, the antenna is placed on the rotor, the motion of the radiating elements themselves causes modulation both because of the varying path length to the antenna at the other end of the link and because of periodically varying interactions between the radiating elements and the airframe itself. Now, if the fields radiated by the moving elements were fixed in space, these periodic variations would be eliminated.

The present antenna is based on the following underlying concept. If one establishes within a cylindrically symmetric radio frequency cavity a mode of oscillation, one may sample the fields of this mode with probes connected to radiating elements and thus radiate the modal energy into free space. The fields of the cavity mode will determine the excitation of the radiating elements. If the mode excitation probes are fixed with respect to the airframe, the cavity mode fields will also be so fixed. If now these cavity fields are coupled to radiating elements via fixed probes inserted into the cavity, clearly the radiation pattern will be fixed with respect to the airframe. However, the key feature of this concept is that if the output probes are rotated about the centerline of the cavity, the radiation pattern will remain fixed with respect to the airframe regardless of the rotation. This feature is illustrated in Figure 1.

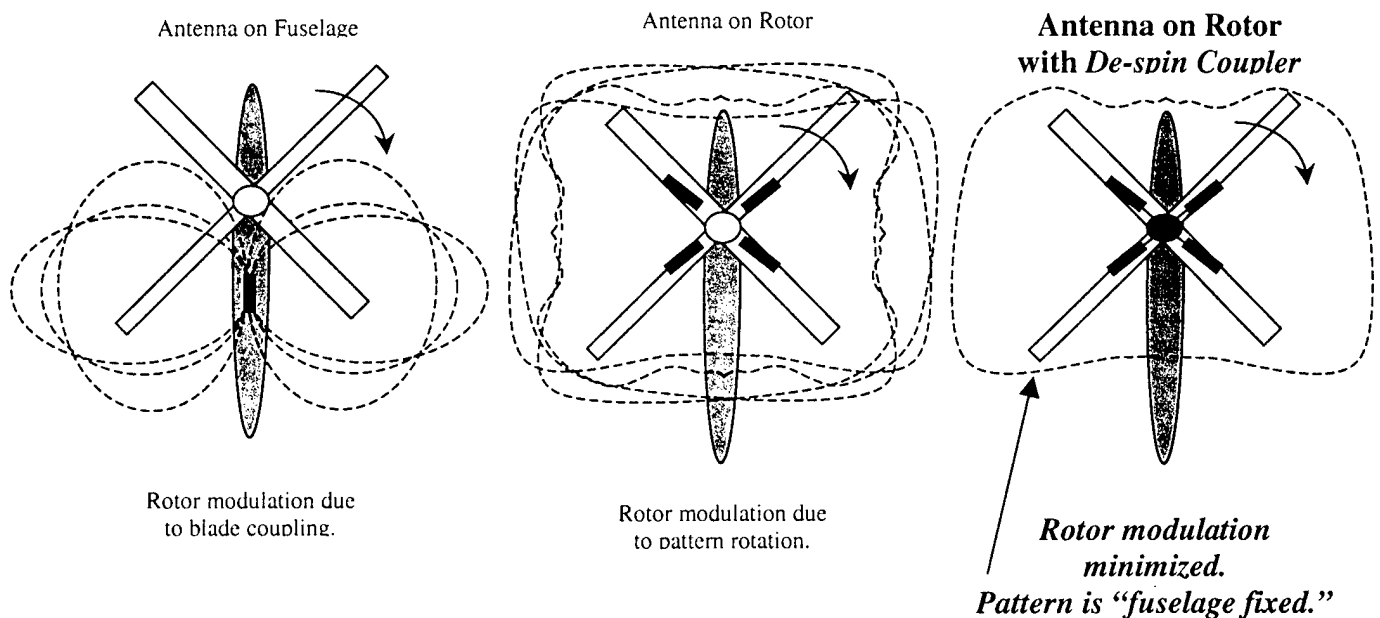

Figure 1. Pattern variation with rotor modulation

The Design of the Coupler

To implement the above concept, a cylindrical coaxial cavity is envisioned. At the input end of the cylinder, four loops are installed which couple to the magnetic field at the end cap of the cavity. At the output end of the cavity there are four output loops which similarly couple to the magnetic field at the output cap of the cavity. The output cap and these probe loops will be free to rotate about the centerline of the cavity. Simple radiating elements (monopoles) are connected to the output probes and arranged in a circle on top of the cavity to radiate into free space. The dimensions of the cavity are selected such that the TEM coaxial mode, the TE_{11} coaxial mode, and the TE_{21} coaxial mode propagate and all other coaxial modes are beyond cutoff. The TEM mode has no azimuthal variation while the other two propagating modes have one cycle of variation in azimuth. The axial length of the cavity is chosen so that the TE_{11} mode is resonant and diametrically opposed probes are arranged to couple strongly to this mode. Two sets of probes are arranged at right angles and excited 90 degrees apart in phase so as to create a rotating TE_{11} mode in the cavity which will excite the output probes in a 90 degree phase sequence. When connected to vertical monopoles arranged in a circle on top of the cavity, this will result in an azimuthally uniform pattern with one cycle of phase variation in azimuth. When the radiated field is measured, the stationary nature of the pattern will be manifest in a constant phase as the radiating elements are rotated about the coupler centerline.

The coupler designed to operate at 3 GHz according to the above specifications is shown in Figure 2. Using the well-known theory of coaxial waveguides [1], one finds that for the dimensions shown, the TEM mode resonates at 2.62 GHz (and harmonics thereof) while the TE_{11} mode resonates as desired at 3 GHz. The TE_{21} mode resonates at 3.96 GHz while the higher order modes resonate above 5 GHz and are cutoff. The excitation probes are located halfway between the inner and outer walls of the coaxial waveguide. At this location they do not couple to the TE_{21} mode. Moreover, the phasing of the excitation of the probes is orthogonal to the azimuthal variation of the TE_{21} mode. Thus, the TE_{11} mode is selectively excited. The fields of the TE_{11} mode are shown in Figure 3 in which the arrangement of coupling loops appropriate to this mode is also indicated. In coupling to this mode, these two loops may be fed through a 180 degree hybrid coupler or one of the loops can be physically reversed in the cavity and the two fed with a power divider. This latter technique is the one used in the measurements to be described below.

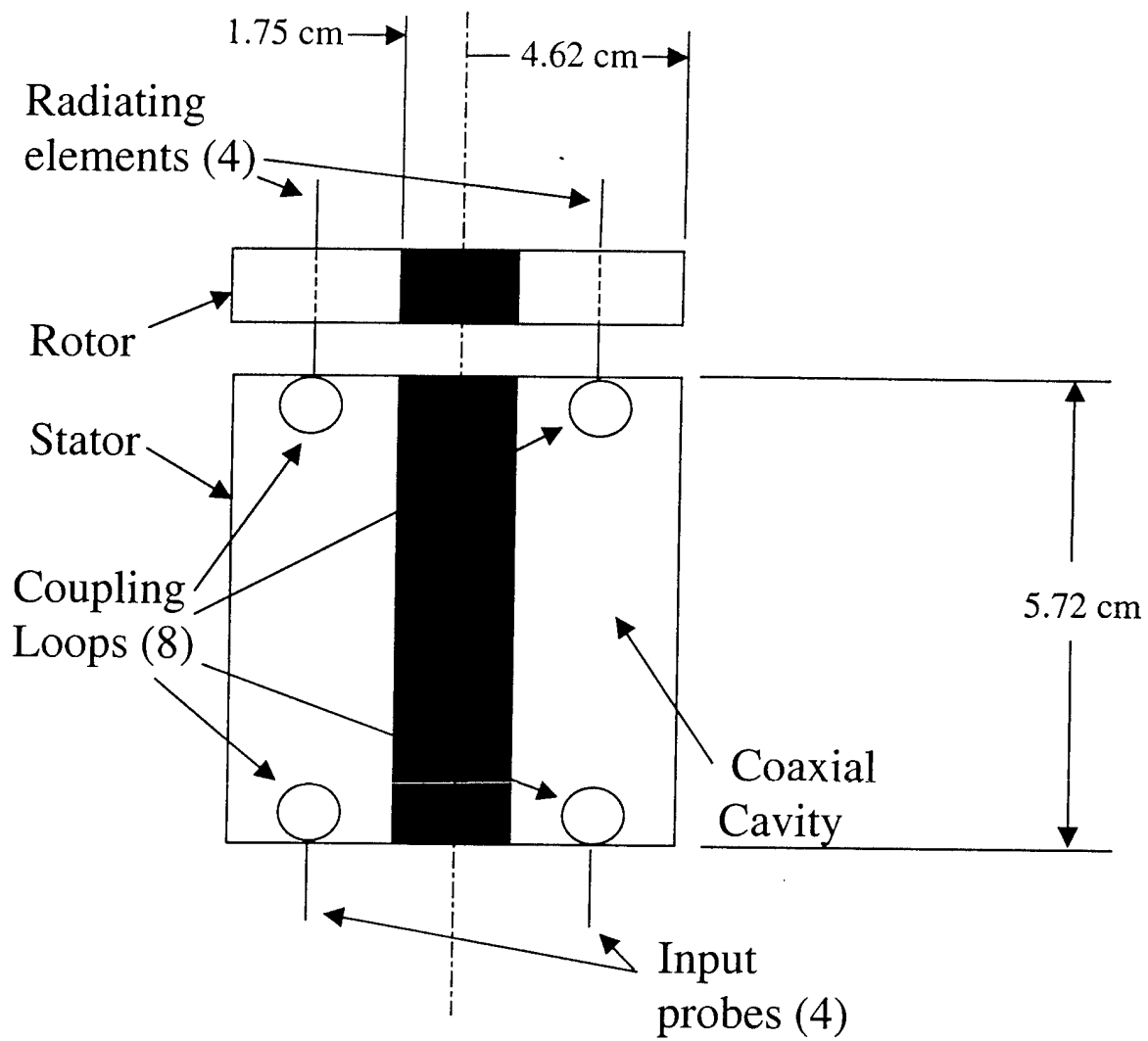

Figure 2. Coupler design.

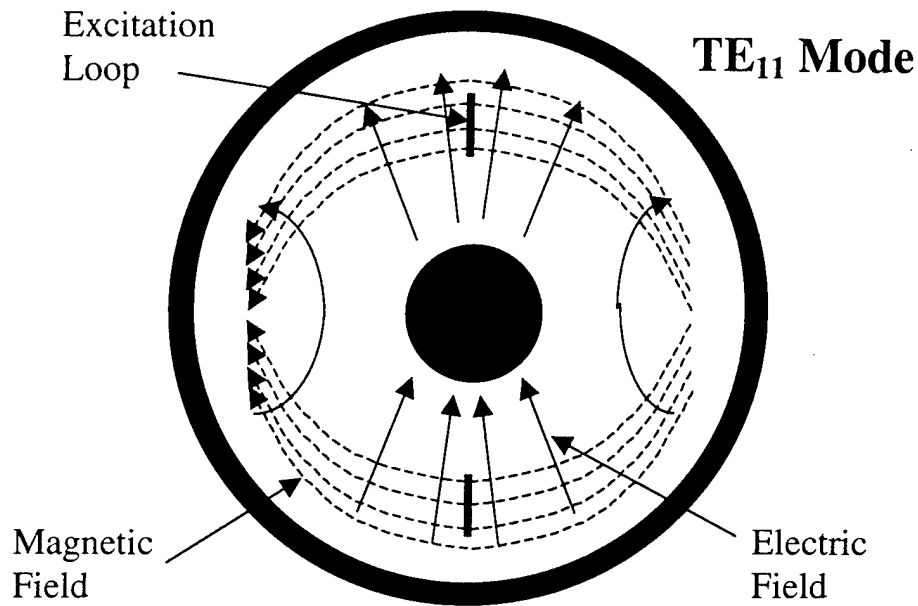

Figure 3. Field distribution of the TE_{11} mode.

Fabrication of the Coupler and Mockup

The coaxial cavity consists of an aluminum cylinder (9.24 cm inner dia., 1.0 cm wall, 5.72 cm len.), two close-fitting aluminum endcaps (top & bottom), a 3.49 cm diameter aluminum centerpost (center conductor), and 8 SMA bulkhead flange connectors. Four equally spaced connectors with 1.0 cm diameter loop-probes were placed on each endcap; four input probes on the bottom (stator) and four output probes spinning with the top (rotor). The output probes were arranged with loop-planes normal to the circumferential direction and were oriented with magnetic fields directed in the same CCW sense. The input probes were also arranged with their loop-planes normal to the circumferential direction, but the orientation of diametrically opposite loops was reversed. See Figure 4 below.

To assemble the cavity, the centerpost was press-fitted into the bottom endcap and the bottom endcap was attached to the cylinder. The top endcap formed a slip-fit to the cylinder top and centerpost, hence, the top was free to spin. The cavity assembly was mounted to an aluminum interface plate and a d.c. motor and drive assembly was attached to interface plate with a belt to drive the top endcap. See Figure 5 below.

Vertically polarized radiation was obtained by inserting four wire monopoles into the output connectors. However, since the diameter (circle) of output connectors on the rotor was $.67\lambda$, the initial section of each element was bent radially inward to bring the diameter of the effective array down to $.4\lambda$. See Figure 6 below.

Horizontal polarization was obtained by replacing the four monopoles with a turnstile of bent wires. The upper most portion of each wire was bent radially outward to form one-half of a $\frac{1}{2}\lambda$ dipole. Opposite pairs were fed from a small diameter center section of "balanced" vertical feed lines. The phasing between these crossed dipoles was 90° (turnstile) due to the excitation of dual orthogonal TE_{11} modes in the cavity. See Figure 6 below.

Simulated helicopter "body-tail" plates (76 cm len. body, 25 cm high tail) were attached to the interface plate and rotor blade was attached to the cavity rotor. This assembly was fitted to a positioner mounting plate to facilitate radiation pattern measurements as shown in Figure 7. For tests without the rotor blade, an large aluminum disk was attached to the cavity rotor in an attempt to hide the cavity-motor assembly and , therefore, to isolate the multipath to the tail section only. The cavity assembly with the aluminum disk and body-tail plates mounted to the positioner is shown in Figure 8.



Rotor

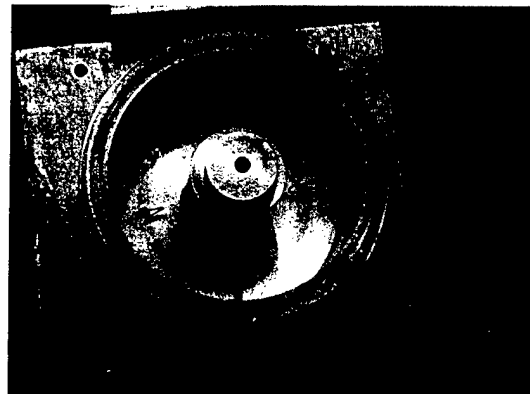

Stator

Figure 4. Interior of the coupler.

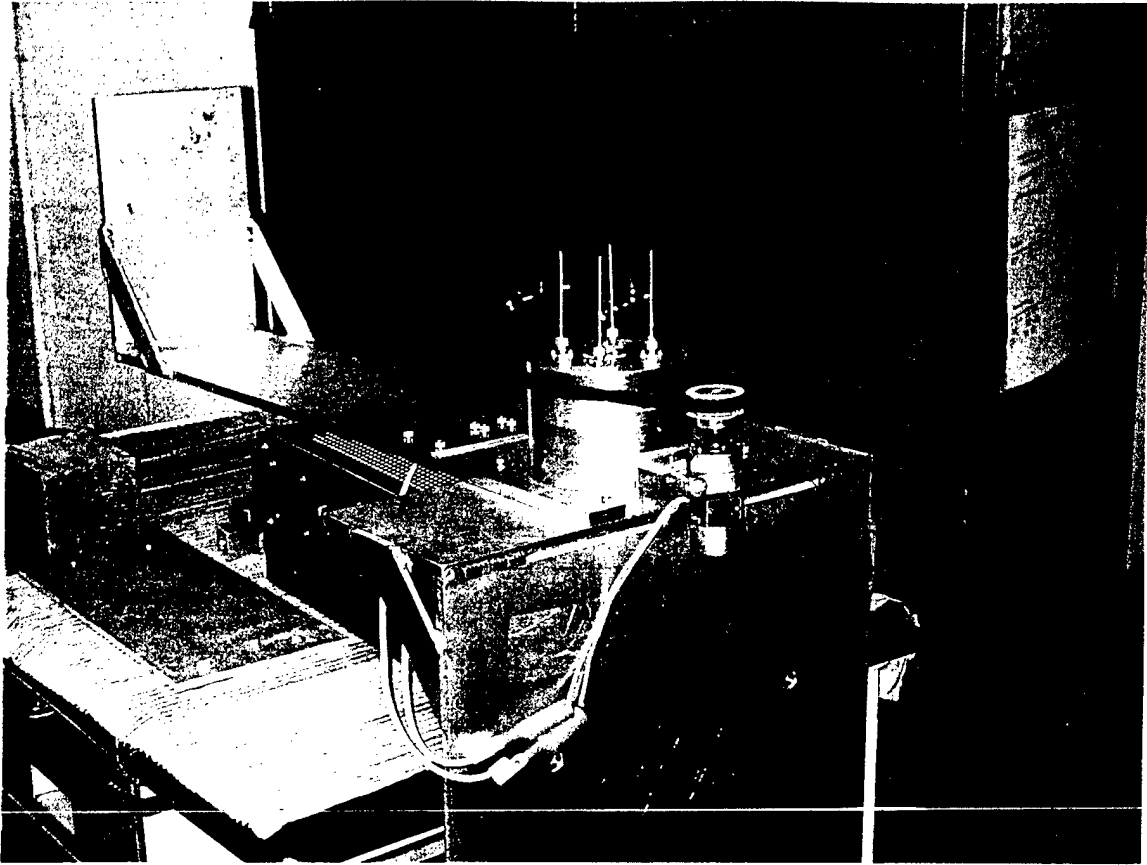
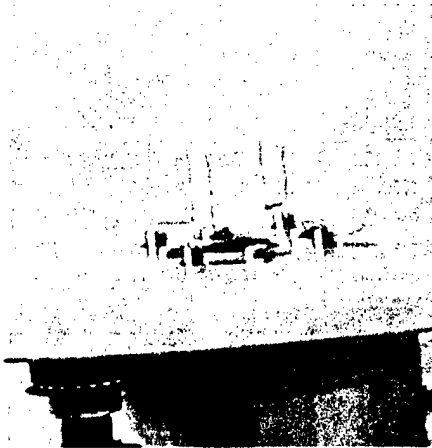
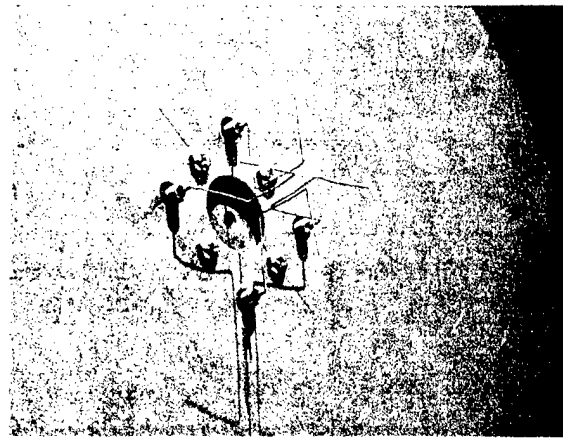

Figure 5. Assembled cavity with motor and belt drive.



Bent Vertical Monopoles



Horizontal Turnstile

Figure 6. Radiating elements on output ports.

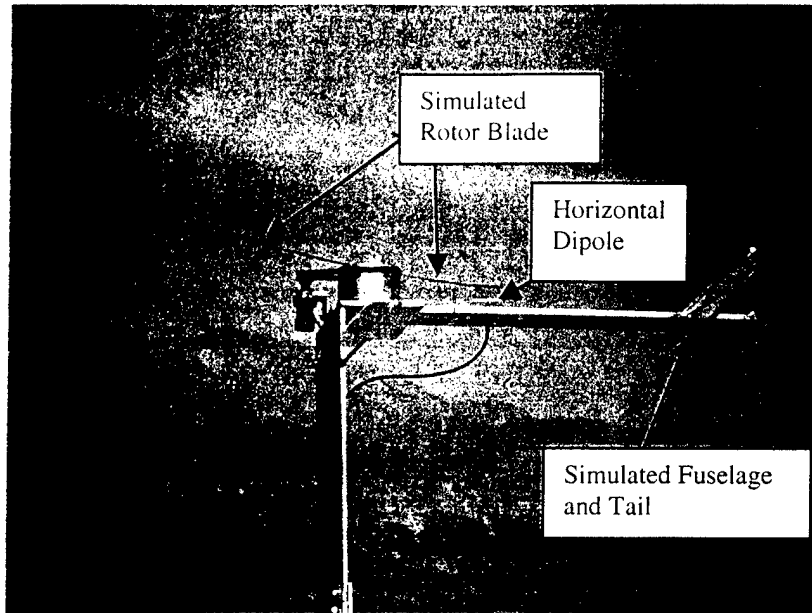

Figure 7. Cavity assembly with rotor blade and body-tail plates mounted to positioner. The single dipole antenna on the body was used to demonstrate rotor blade modulation.

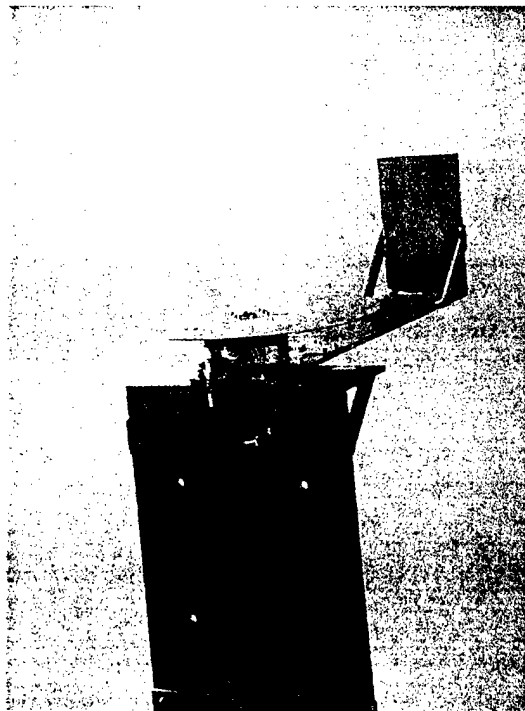

Figure 8. Cavity assembly with aluminum disk and body-tail plates mounted to positioner.

Measurements

A network analyzer spectral scan of S_{12} for the coupler from one input probe to one output probe is shown in Figure 9 and the resonant peaks of the three propagating modes are evident. The peaks near 5 GHz and above are due to higher order cutoff modes as well as the harmonics of the TEM mode resonance.

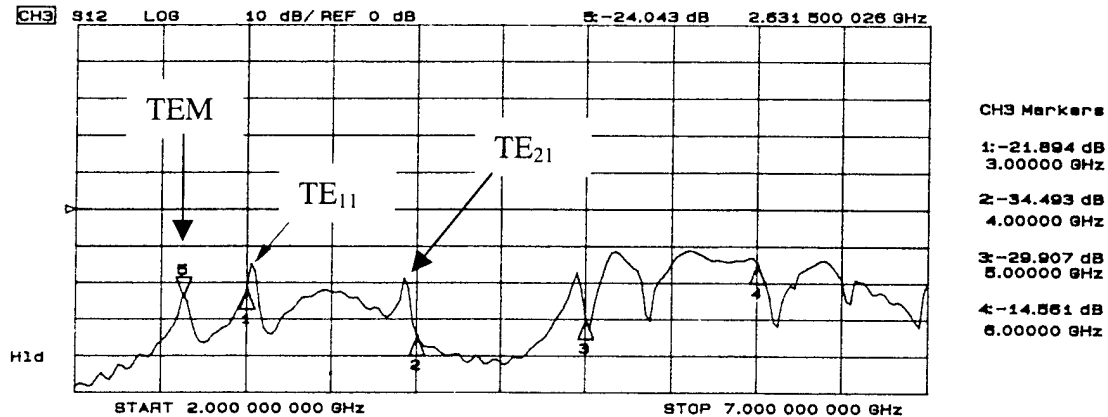

Figure 9. S_{12} of the coupler in Figure 4.

Next a pair of TE_{11} modes was excited by feeding two power dividers through a 90 degree hybrid coupler. The opposing loops were arranged to couple to the TE_{11} mode and the two TE_{11} modes thus excited were 90 degrees out of phase as shown in Figure 10. The aluminum disk was used to hide the cavity-motor assembly (see Figure 8). Using this configuration patterns were measured for five fixed positions of the rotor portion of the coupler; i.e., 0, 45, 90, 135 and 180 degrees. These are shown in Figures 11a – 11e. These patterns show that the amplitude is nearly azimuthally isotropic while the phase cycles through 360 degrees as the azimuth angle varies from -180 to $+180$ degrees as expected for the two TE_{11} modes excited. The pattern shown in Figure 12 was taken with the rotor portion of the coupler driven by the motor. The oscillations are indicative of the degree of azimuth independence of the radiation pattern of the radiating array on top of the coupler. Variations in the cavity mode field with azimuth appear in this figure as the variations with azimuth of the average over the rapid oscillations. Note that the phase does not cycle with rotation. Thus, this phase may be used to derive azimuth angle of arrival information when receiving a signal.

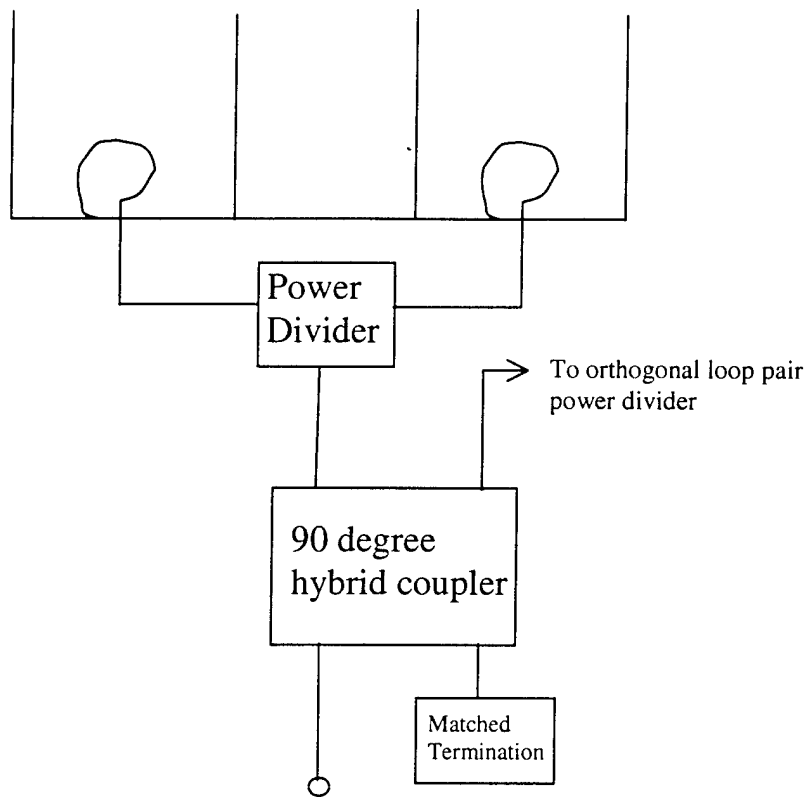

Figure 10. Feed arrangement for two TE₁₁ modes phased 90 degrees apart.

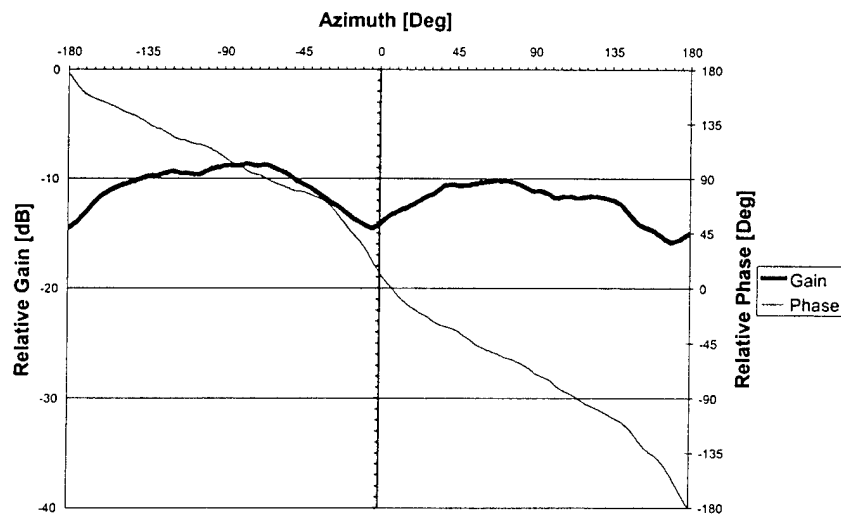

Figure 11a. Radiation patterns with rotor fixed at 0 degrees.

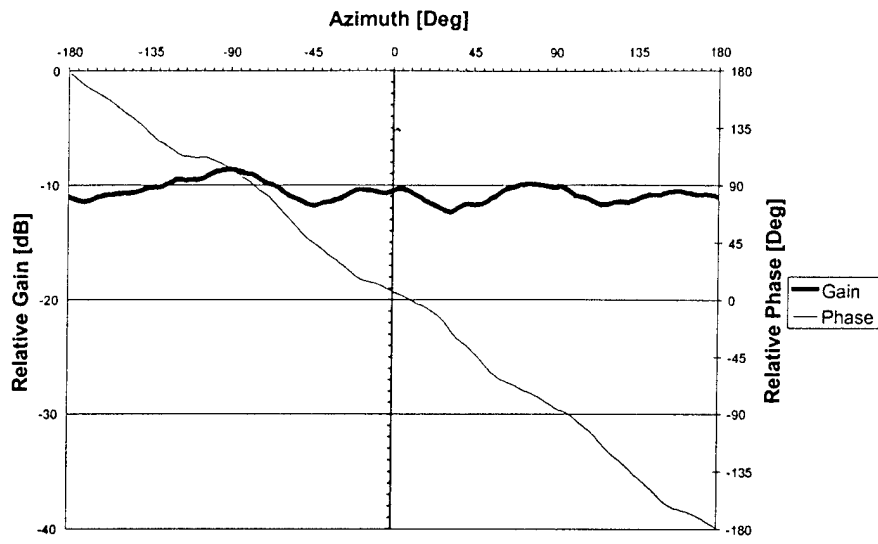

Figure 11b. Radiation patterns with rotor fixed at 45 degrees.

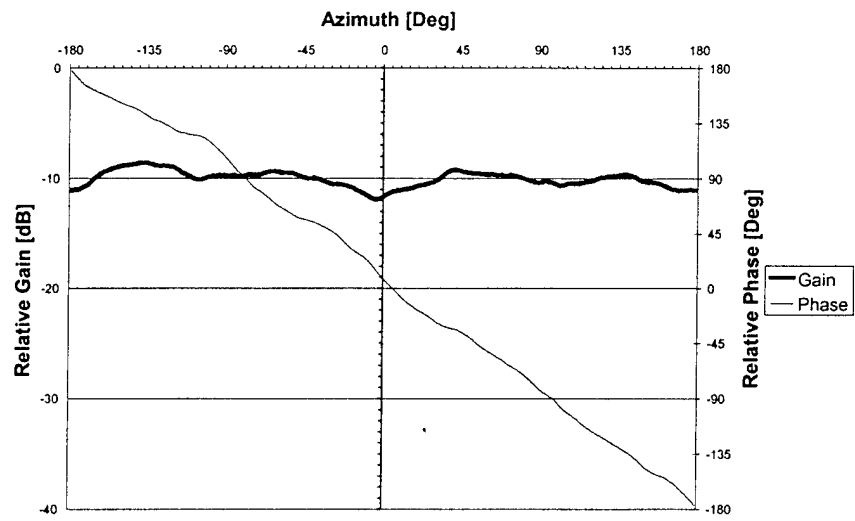

Figure 11c. Radiation patterns with rotor fixed at 90 degrees.

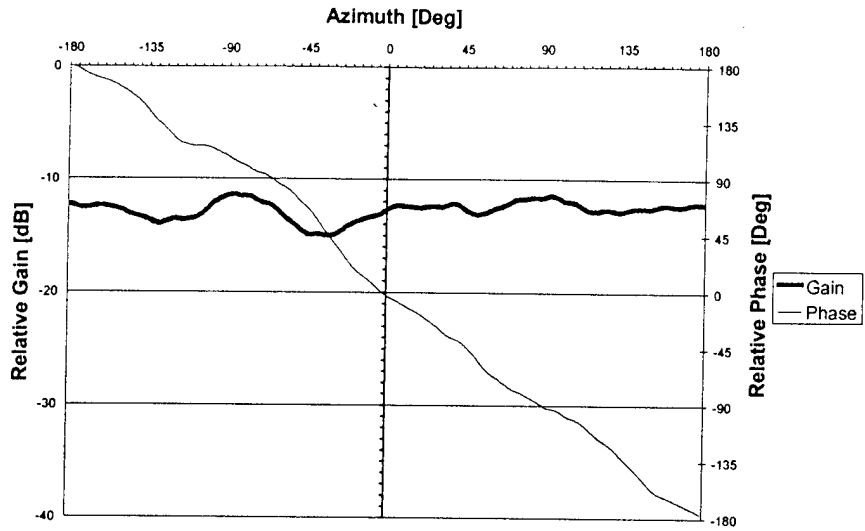

Figure 11d. Radiation patterns with rotor fixed at 135 degrees.

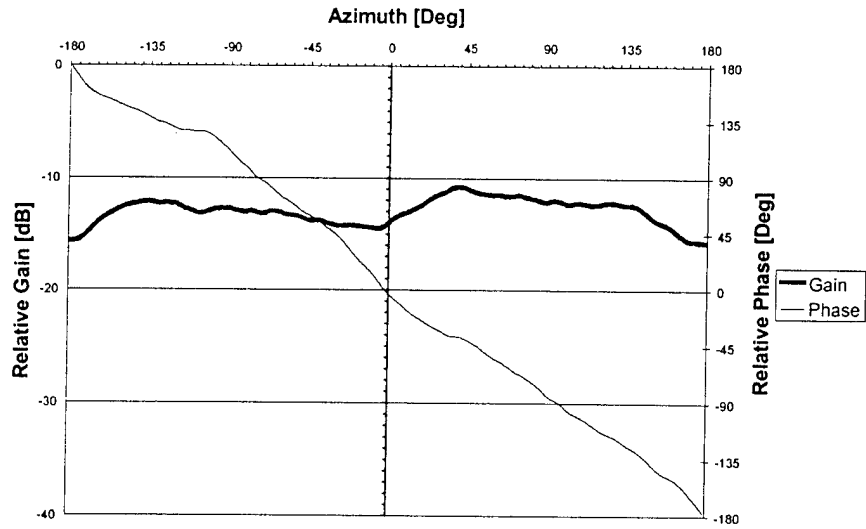

Figure 11e. Radiation patterns with rotor fixed at 180 degrees.

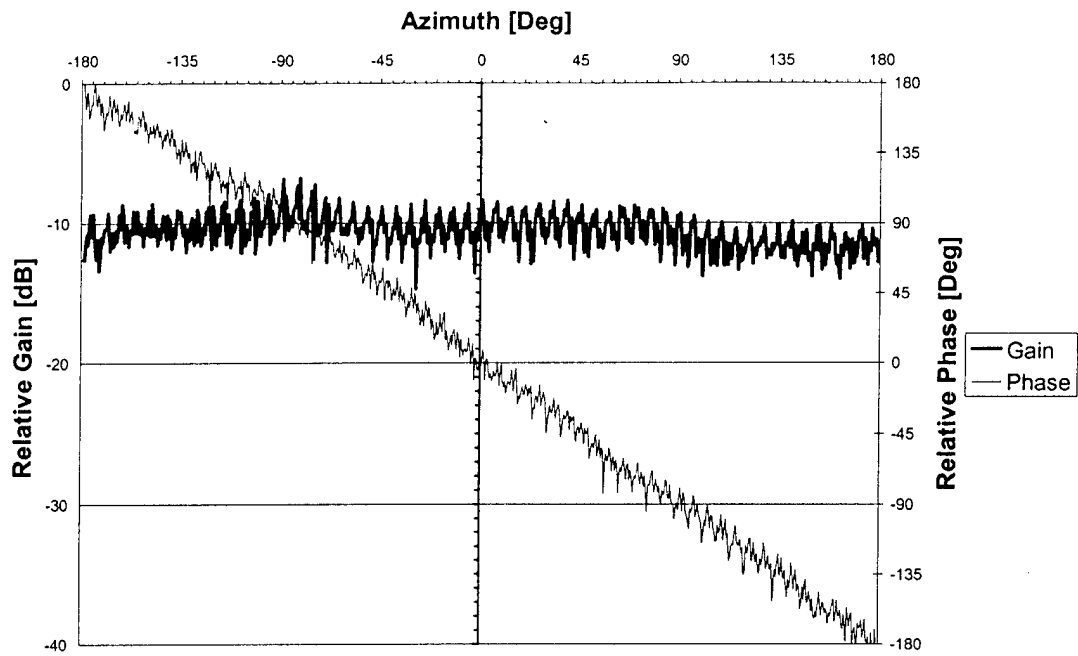

Figure 12. Radiation pattern with rotor spinning.

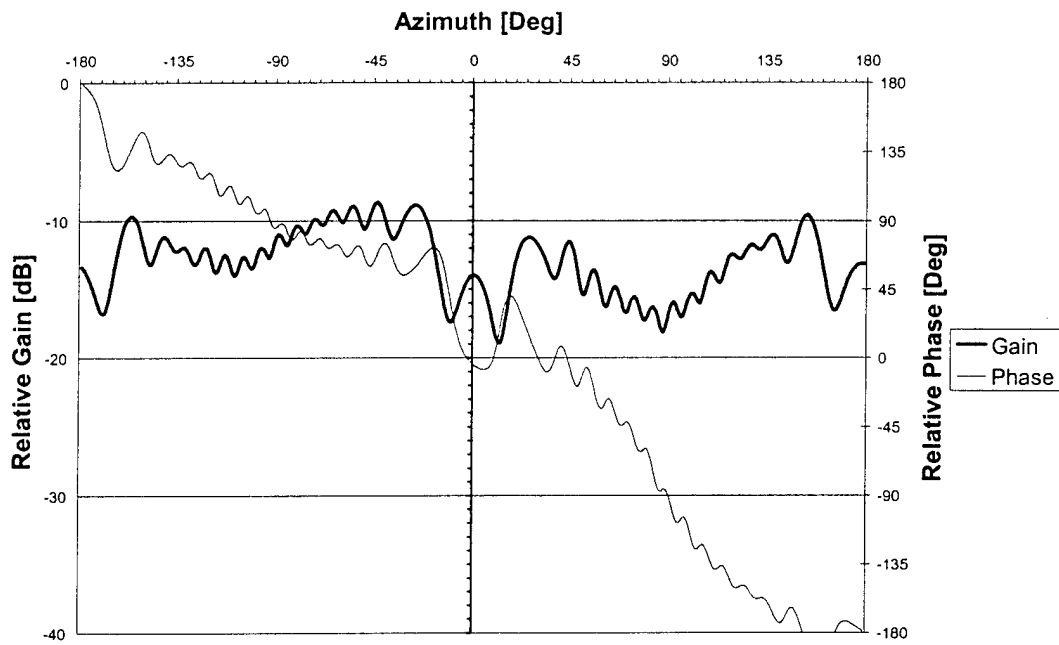

Figure 13a. Radiation pattern for rotor at 0 degrees with simulated tail.

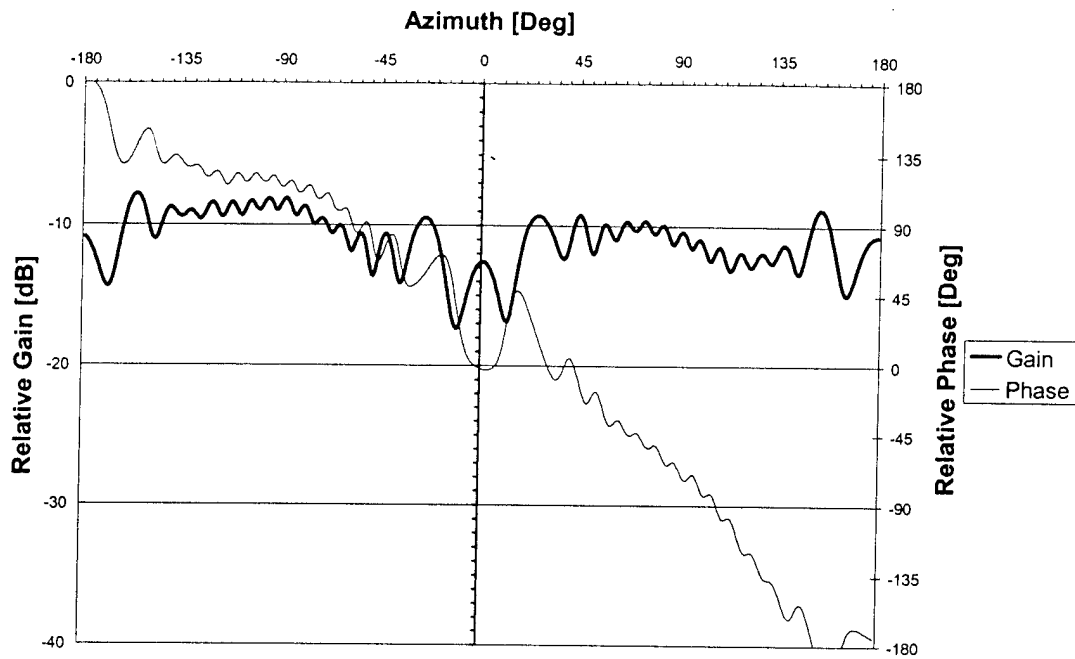

Figure 13b. Radiation pattern for rotor at 45 degrees with simulated tail.

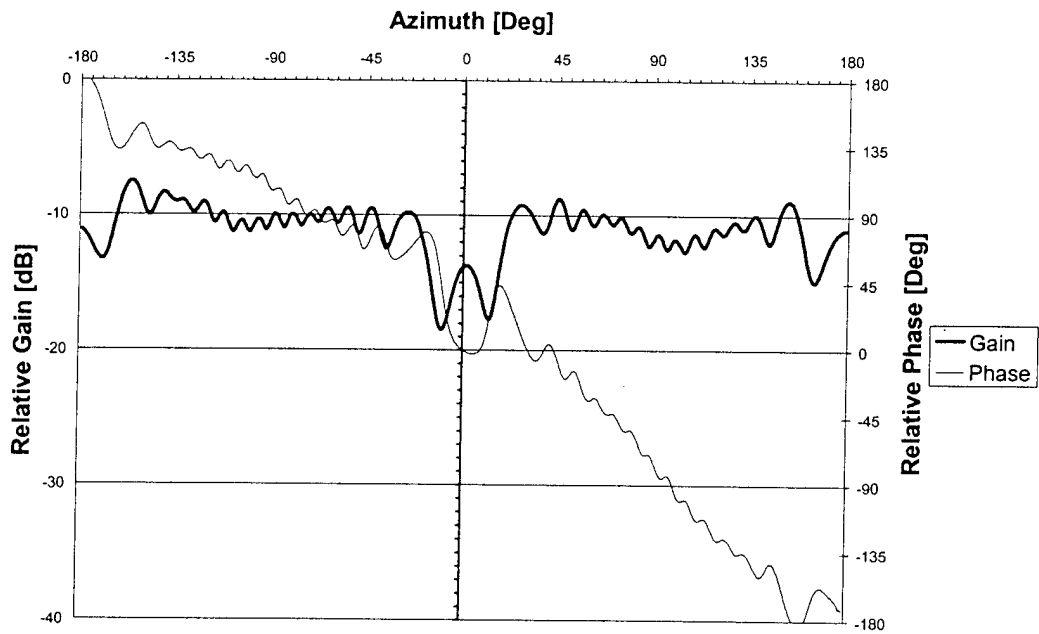

Figure 13c. Radiation pattern for rotor at 90 degrees with simulated tail.

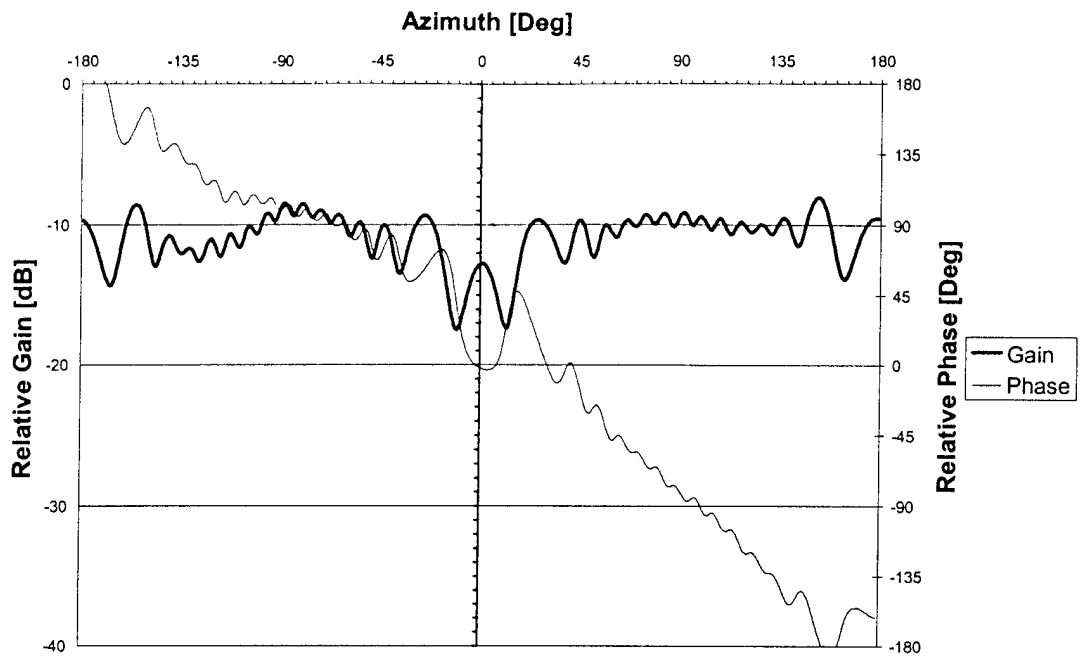

Figure 13d. Radiation pattern for rotor at 135 degrees with simulated tail.

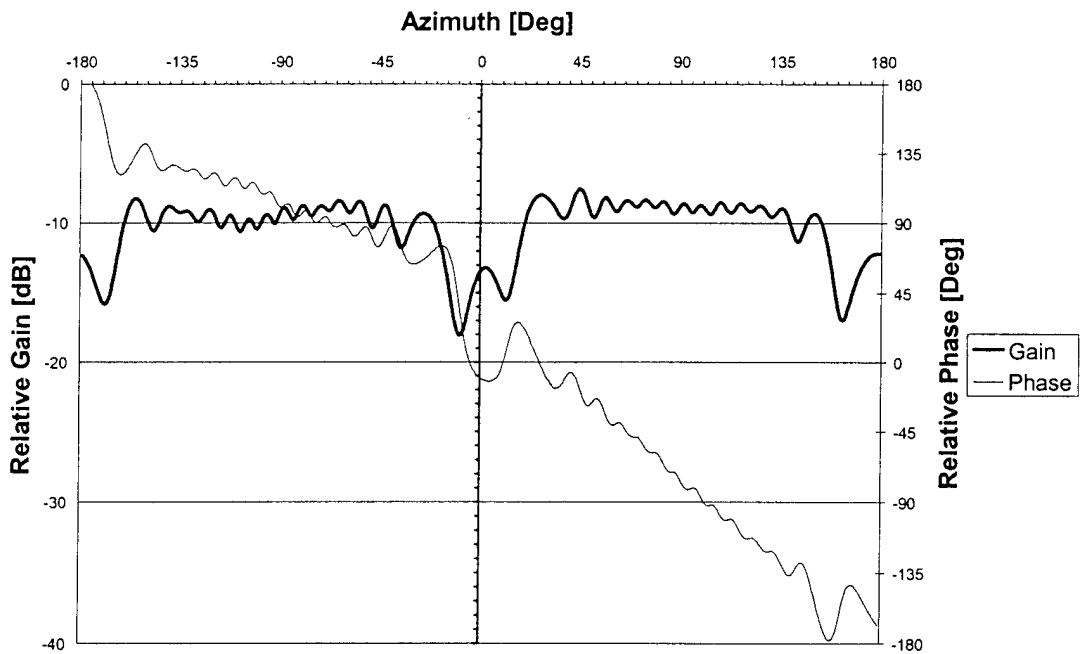

Figure 13e. Radiation pattern for rotor at 180 degrees with simulated tail.

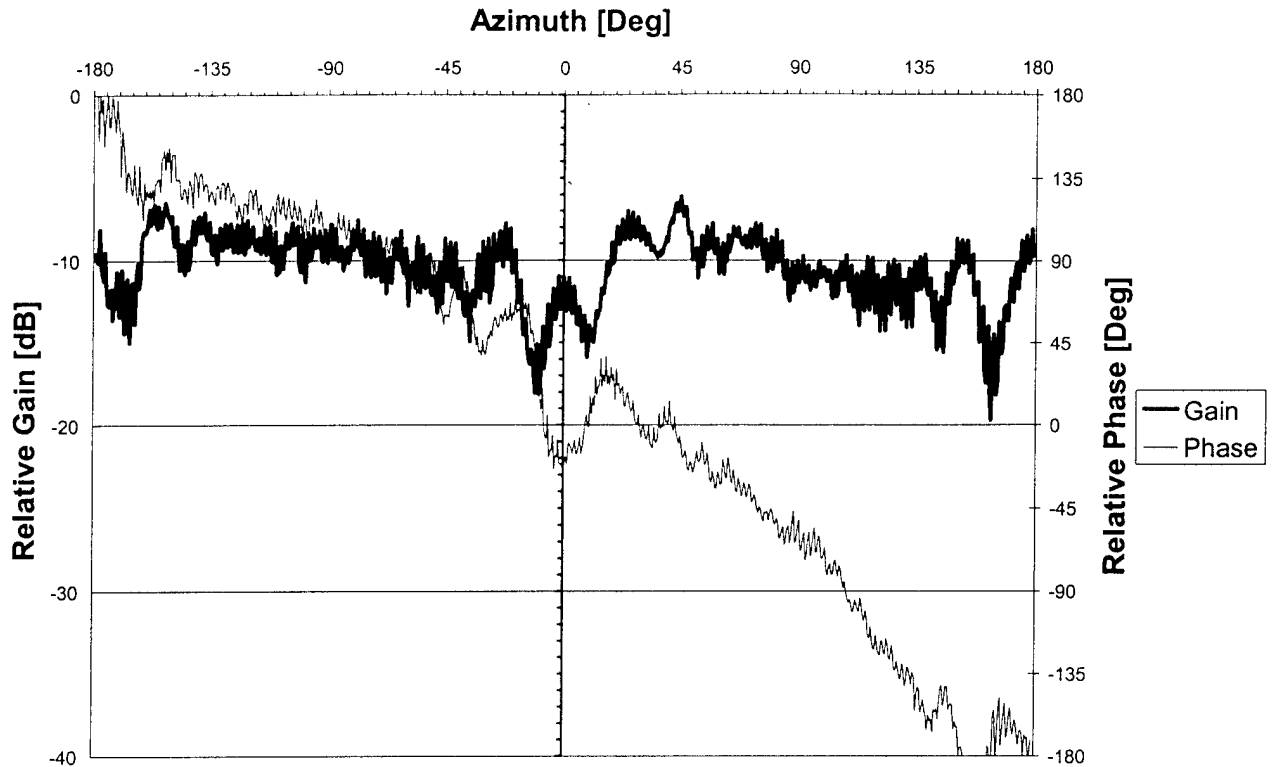

Figure 14. Radiation pattern for spinning rotor with simulated tail.

The measurements shown in Figure 13 were taken with the simulated airframe (aluminum bracket) in place. Here again, an aluminum disk was used to hide the cavity-motor assembly (see Figure 8). Here we see that the pattern is not isotropic but remains fixed with respect to the airframe as the coupler rotor is indexed. Figure 14 shows the result of continuous rotation analogous to Figure 12. Angle of arrival measurement is more difficult here because the phase curve is distorted due to interaction with the tail. This, however, can be calibrated because the pattern is fixed with respect to the airframe.

Finally, a measurement was taken of the pattern of a dipole mounted on the simulated airframe (see Figure 7). In this case, two simulated rotor blades were added to the rotor, replacing the aluminum disk. The resulting pattern of the dipole is shown in Figure 15. Figure 16 shows the result of rotating the rotor blades to simulate the usual rotor modulation situation. Figures 17 and 18 show the corresponding results with the simulated tail in place.

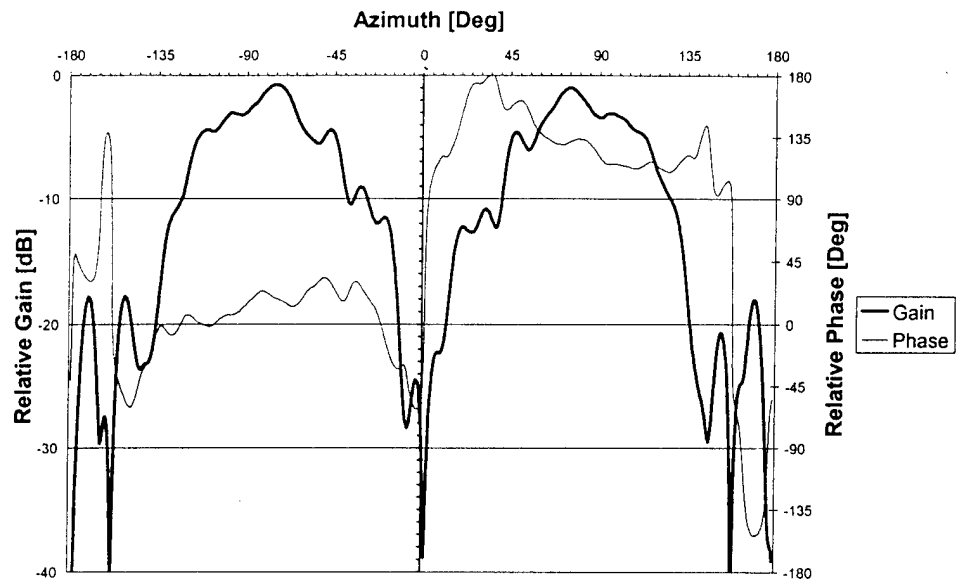

Figure 15. Pattern of fixed horizontal dipole with fixed rotor.

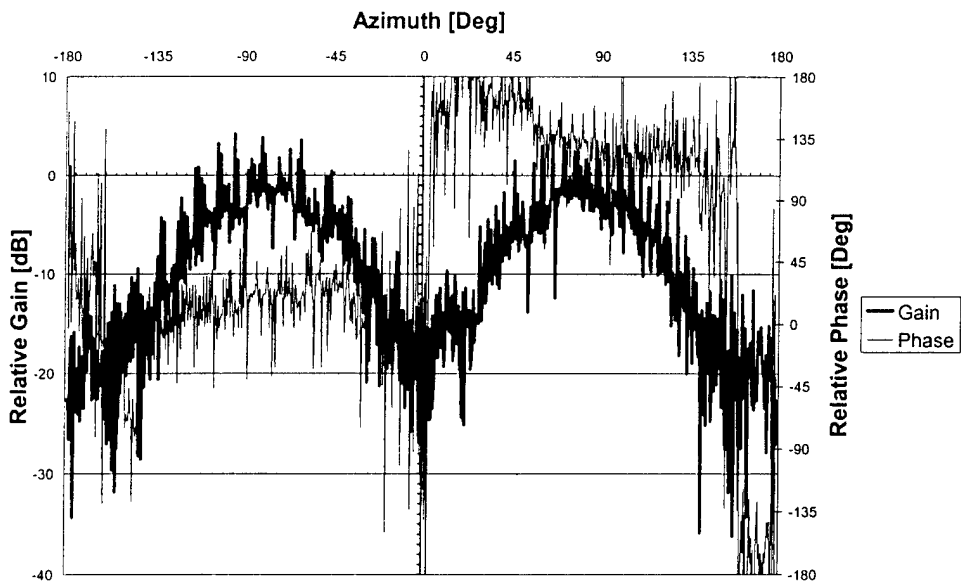

Figure 16. Pattern of fixed horizontal dipole with spinning rotor.

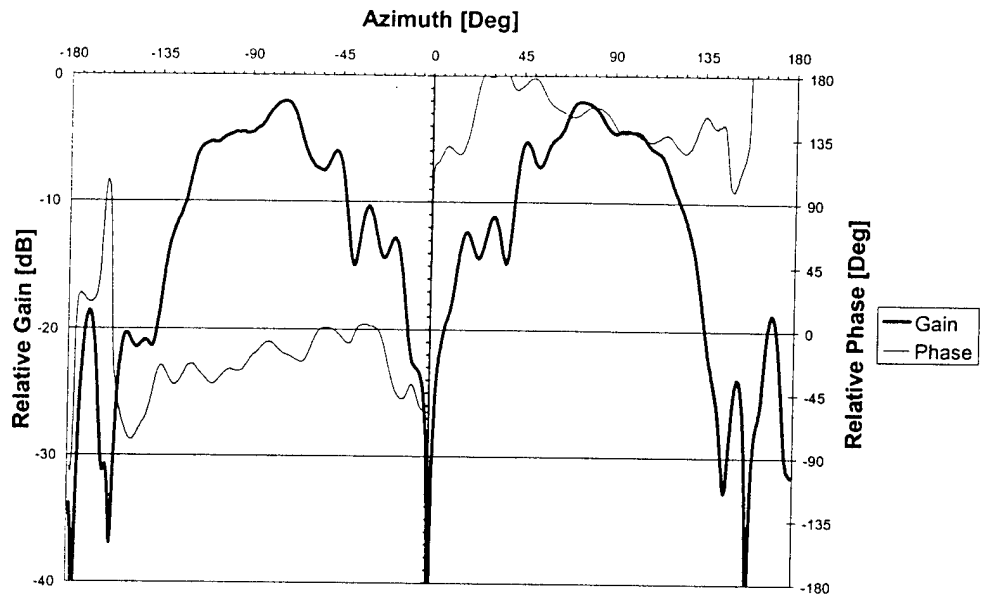

Figure 17. Pattern of fixed horizontal dipole for fixed rotor with simulated tail.

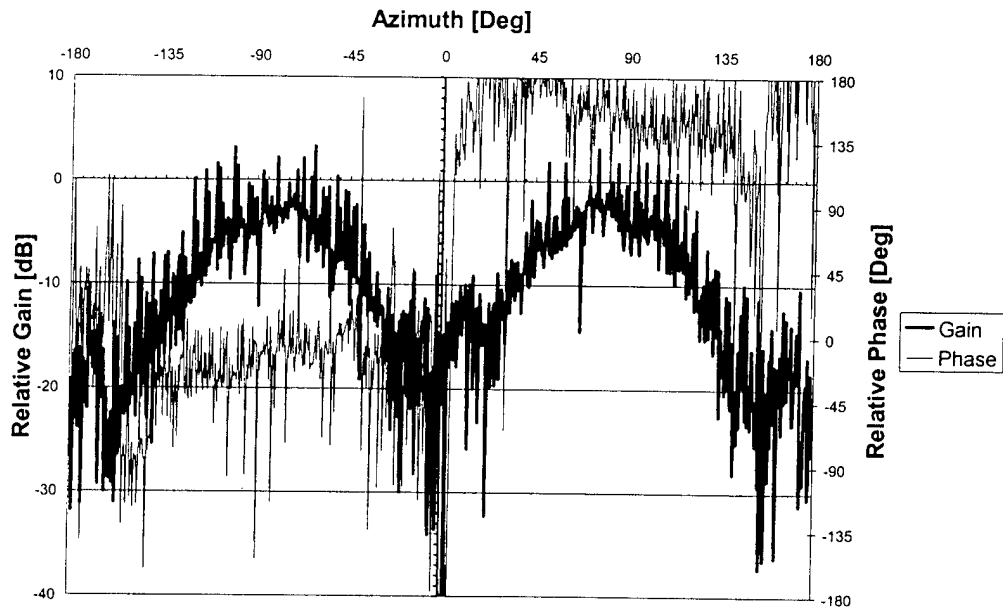

Figure 18. Pattern of fixed horizontal dipole for spinning rotor with simulated tail.

Finally, the vertical monopoles on the rotor were replaced with horizontal monopoles corresponding to horizontal polarization and patterns were measured for three fixed rotor positions with no rotor blade, no disk, and not tail. These patterns are shown in Figure 19. Figure 20 shows the result of spinning the rotor during the measurement.

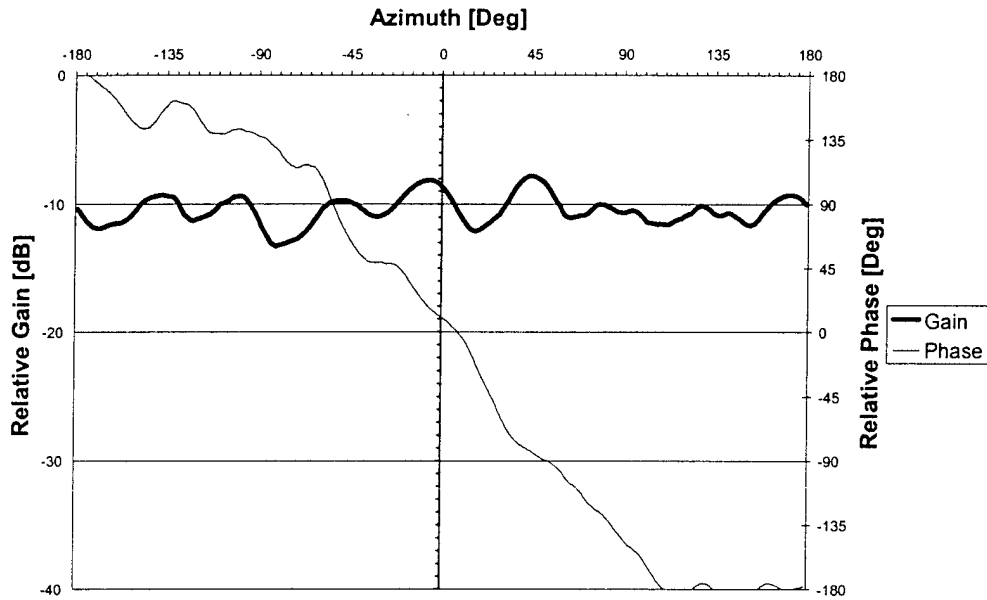

Figure 19a. Radiation pattern of horizontal monopoles with rotor fixed at 0 degrees.

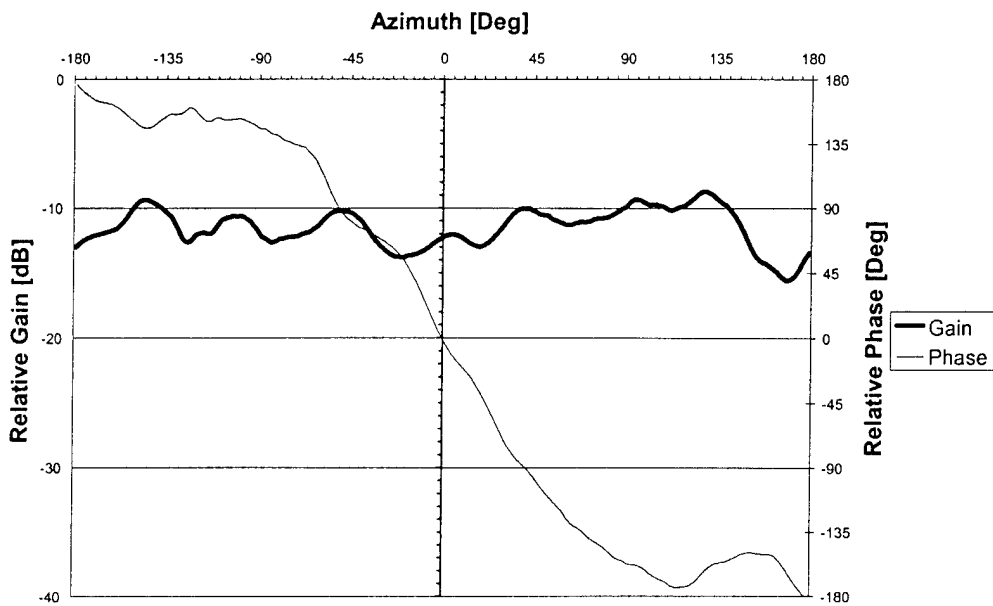

Figure 19b. Radiation pattern of horizontal monopoles with rotor fixed at 45 degrees.

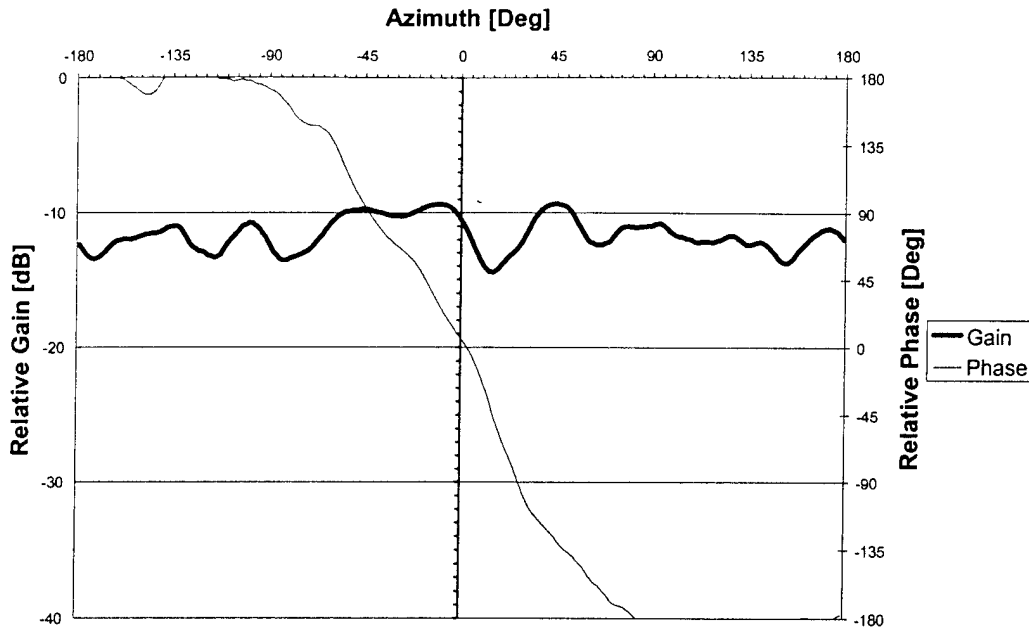

Figure 19c. Radiation pattern of horizontal monopoles with rotor fixed at 90 degrees.

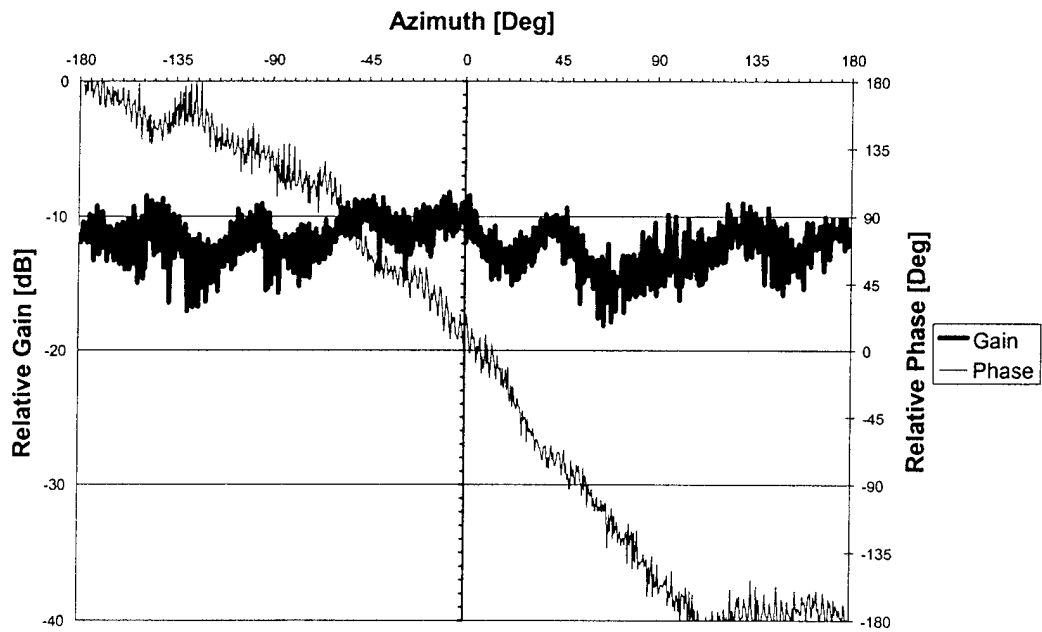

Figure 20. Radiation pattern of horizontal monopoles with spinning rotor.

Discussion of Results

From the results shown in Figures 11 through 20 one may infer a number of conclusions concerning the efficacy of pattern despinning in mitigation of rotor blade modulation effects. Beginning with Figure 11 we see that the pattern amplitude is nearly azimuthally uniform in amplitude and that the pattern phase varies nearly linearly at a rate consistent with the TE_{11} mode of the coaxial cavity. Furthermore, as the rotor is clocked through several fixed azimuthal positions, the pattern stays relatively constant in magnitude and phase. This allows one to anticipate that the signal variation with rotation of the rotor at a fixed azimuth will be fairly small and this fact is confirmed by the results shown in Figure 12. Here the rotor modulation is about ± 2 dB in amplitude and about ± 10 degrees of phase. We believe that this level can be reduced by careful adjustment of the cavity excitation and by moving the vertical monopoles closer to the axis of rotation.

Figures 13 and 14 indicate that similar results are obtained in the presence of the simulated fuselage (tail). In particular, it is clear that the pattern is fixed with respect to the airframe regardless of rotation of the rotor. This is an important feature of the coupler in that it unequivocally demonstrates the despinning effect.

For comparison purposes, the pattern of a horizontal dipole on the simulated fuselage was measured and, as shown in Figure 16, the resulting rotor modulation is about ± 10 dB in amplitude and about ± 50 degrees of phase, or about five times greater than that observed using the despinning coupler. Again, we believe that the modulation level with the coupler can be further reduced with more careful adjustment of the coupling loops, a study of which was not consistent with current resources.

Finally, Figures 19 and 20 indicate that similar performance may be obtained in horizontal polarization. These results again highlight the pattern despinning effect in that the original pattern shape of the fixed rotor configuration is clearly visible in the spinning rotor measurements. This is clear evidence that the underlying pattern is not rotating.

Concluding Remarks

The measurement program described here clearly demonstrates that the operating principles of the JPL rotor antenna coupler are sound and that such a coupler can be effective in mitigating rotor modulation effects. The reference measurement of a dipole modulated by a rotor blade pair showed approximately ± 10 dB of modulation. This is somewhat greater than the ± 1.5 to 3 dB average level reported recently by Birtcher, Balanis, and DeCarlo at 100 MHz.[2] This scales to approximately 1.7GHz for our model size which is very roughly half our measurement frequency. While this is highly dependent on the particular physical configuration, it does point up the fact that the ± 2 dB level of the current coupler should be improved by more careful adjustment of the coupling loops and possibly better mode control in the cavity.

Further Work *Partially* Funded by ARO

In an effort to more fully understand the cavity modes, measurements of the field distribution in the cavity were made. It was noted that a field amplitude variation with azimuth of about 3 dB was present and that this variation occurred once per 360 degrees of azimuth. Such variation is consistent with the simultaneous presence of the TE_{11} and TEM modes. To eliminate the TEM mode while preserving the desired TE_{11} mode, the center post of the cavity was cut near the output end cap. This reduced the azimuthal variation of the cavity field to 0.3 dB indicating the potential for very significant reduction in the rapid oscillations shown in Figures 12, 14, and 20. Unfortunately, resources did not permit successful demonstration of this effect via far field pattern measurement.

References

1. N. Marcuvitz, Waveguide Handbook, McGraw-Hill, New York, 1951, pp. 72-80.
2. C. R. Birtcher, C. A. Balanis, and D. DeCarlo, "Rotor-Blade Modulation on Antenna Amplitude Pattern and Polarization: Predictions and Measurements," *IEEE Trans. Electromagnetic Compatibility*, 41, 384-393, Nov. 1999.