

O

F

S

D

**Instruction Manual for Ultrasonic
Noise Recording System**

Mark L. Readhead

DSTO-GD-0285

DISTRIBUTION STATEMENT A
Approved for Public Release
Distribution Unlimited

Instruction Manual for Ultrasonic Noise Recording System

Mark L. Readhead

**Maritime Operations Division
Aeronautical and Maritime Research Laboratory**

DSTO-GD-0285

ABSTRACT

A portable system for recording ambient noise in the sea has been developed. It is suitable for ultrasonic frequencies and can digitise up to a rate of 1 MHz. The hydrophone is attached to the end of a lightweight aluminium pole of 4.5 m extension, which can be dismantled into 1.5 m lengths for ease of transport. The hydrophone has an integral preamplifier which is powered by batteries. The analogue to digital conversion is performed in a box with similar dimensions to a laptop computer. It is powered by another similarly-sized box of rechargeable batteries. The process is controlled by and the data is stored on a laptop computer. Software has been written to display the spectra of the ambient noise. Instructions on the use of the hardware and software are provided.

APPROVED FOR PUBLIC RELEASE

20010801 106

DEPARTMENT OF DEFENCE
DEFENCE SCIENCE & TECHNOLOGY ORGANISATION

DSTO

AQ FOI-10-2153

Published by

*DSTO Aeronautical and Maritime Research Laboratory
PO Box 4331
Melbourne Victoria 3001 Australia*

*Telephone: (03) 9626 7000
Fax: (03) 9626 7999
© Commonwealth of Australia 2001
AR-011-857
April 2001*

APPROVED FOR PUBLIC RELEASE

Instruction Manual for Ultrasonic Noise Recording System

Executive Summary

A portable system for measuring underwater ultrasonic ambient noise has been developed for use by the Maritime Operations Division of DSTO and the Hydrographic Department of the Royal Thai Navy. This report details the instructions on how to use this equipment, covering both the hardware and software aspects.

The hydrophone used is an ITC 8257 model, for which receive sensitivity curves and beam patterns are provided. The hydrophone is clamped to the base of a collapsible 4.5 m pole for easy deployment over the side of a boat. The hydrophone has an integral preamplifier which is powered by a DC-power supply box containing replaceable D-cells.

The analogue to digital conversion is done in a laptop-sized Iotech box at rates to 1 MHz with 12-bit resolution. This module is powered by a similarly sized box containing rechargeable batteries. The output of the conversion is sent to a laptop computer for storage on a hard disk. The data can be later downloaded to a Jaz disk.

The data collection is controlled by the laptop using an Iotech program. This configures the sampling board, collects the data and transfers it to the computer's hard disk. The data is analysed with programs written in Matlab, to produce a spectrum of an extended sample of data. A second program displays a short section of data and its corresponding spectrum. This enables the user to zoom in on transients and examine their spectral content.

Contents

1. INTRODUCTION	1
2. HARDWARE	1
2.1 HardwareOverview	1
2.2 Hydrophone Deployment	1
2.3 Hydrophone	3
2.4 Analogue to digital conversion	6
2.5 Computer storage	6
3. SOFTWARE	7
3.1 Software Overview	7
3.2 Daq Configuration	7
3.3 WaveView	8
3.4 PostView	10
3.5 WbkSpectra.m	10
3.6 WbkSnap.m	12
4. REFERENCES	13
5. APPENDIX	14

1. INTRODUCTION

A lightweight system has been designed for easy deployment and measurement of high frequency ambient noise spectra. It consists of a hydrophone, collapsible pole, power supply, analogue to digital conversion box and laptop computer. It is intended that the system can be deployed from a small boat and the data recorded within a few minutes.

2. HARDWARE

2.1 Hardware overview

The high frequency noise spectra are measured with a directional hydrophone attached to the end of a 4.5 m pole. The hydrophone has an integral preamplifier requiring power from the surface. This is provided by a box containing expendable batteries. The output from the hydrophone is fed into a sampling card contained in a box. This is powered by a rechargeable battery pack. The digitised signal is sent to a notebook computer, where it is logged on a hard disk. The data can later be copied onto a Jaz disk.

2.2 Hydrophone deployment

Figure 1 shows the pole to which the hydrophone is to be attached. It consists of three hollow aluminium tubes, each of 1.5 m length, which are bolted together with two short hollow tubes. Assembly is aided by lubricating those sections of aluminium which slide together. When assembled the total length is 4.5 m.

At the base is a two-orientation holder into which the hydrophone is clamped. It has two clamps, one to hold the hydrophone so that it points along the axis of the pole (vertically), the other to hold it so that it points perpendicular to the pole (horizontally). It would be attached to point along the axis of the pole (vertically) when the operator wishes to record the ambient noise predominantly originating directly below on the sea floor.

More commonly the hydrophone would be attached to the other clamp, so that it points perpendicularly to the pole (horizontally). In this case it would be used to record ambient noise coming in from the side. When deployed the operator should note in which direction (e.g. N or NE) the hydrophone is pointing. This is aided by looking at the orientation of the hydrophone with respect to the nuts and bolts holding the sections of the pole together. When the hydrophone and pole are lowered into the water, either the nut or bolt visible above the water surface will point in the direction of the hydrophone. The hydrophone beam pattern of the receiving response is broad, so that the direction does not need to be very precise.

Once the hydrophone has been clamped in position, the cable should be cable-tied to the pole at a few positions along its length. The cable tie closest to the hydrophone should not place strain on the junction of cable and hydrophone. Figure 2 shows the pole assembled, with the hydrophone attached in the perpendicular orientation.

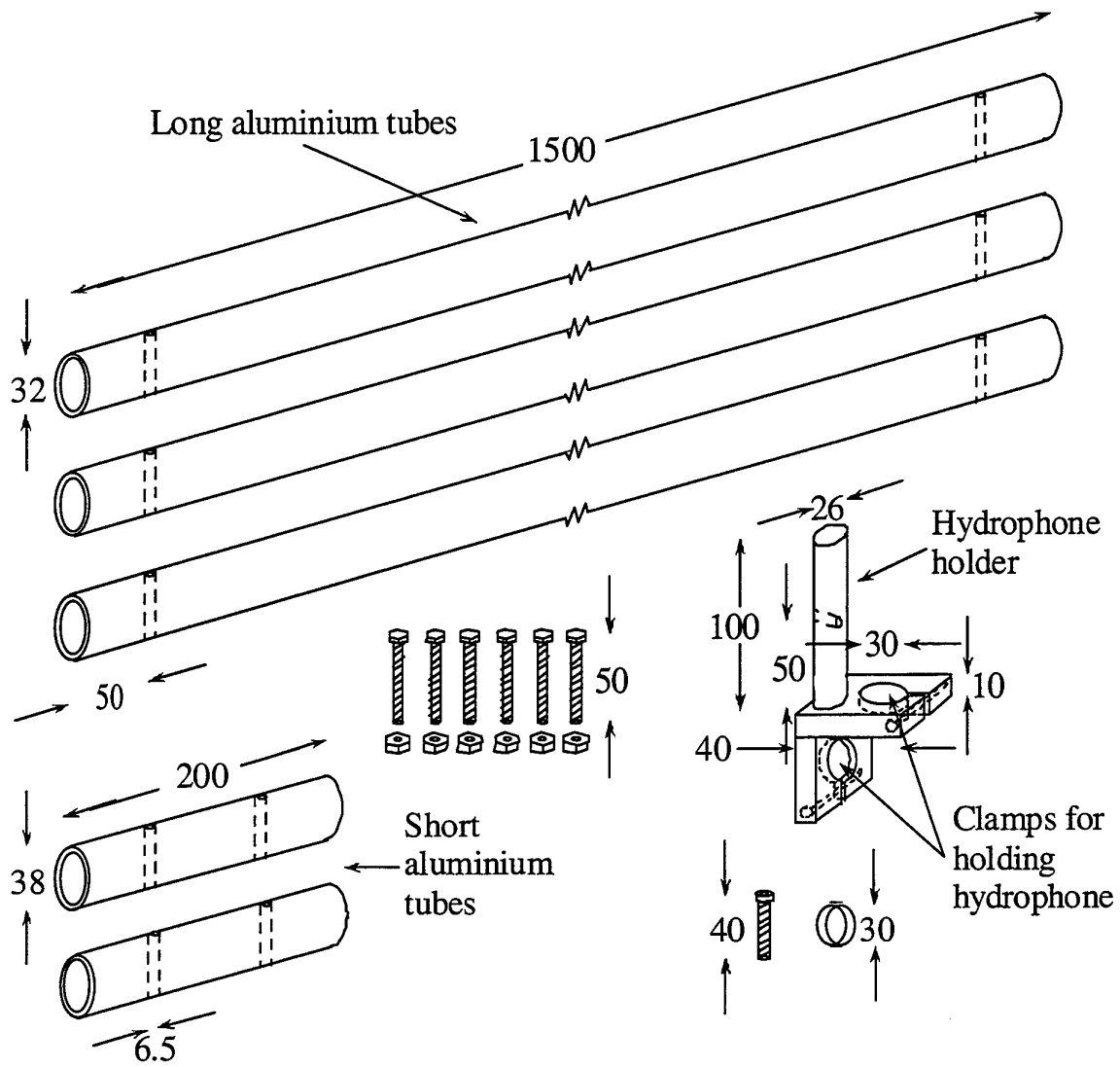

Figure 1. Components of pole assembly. All dimensions are in mm.

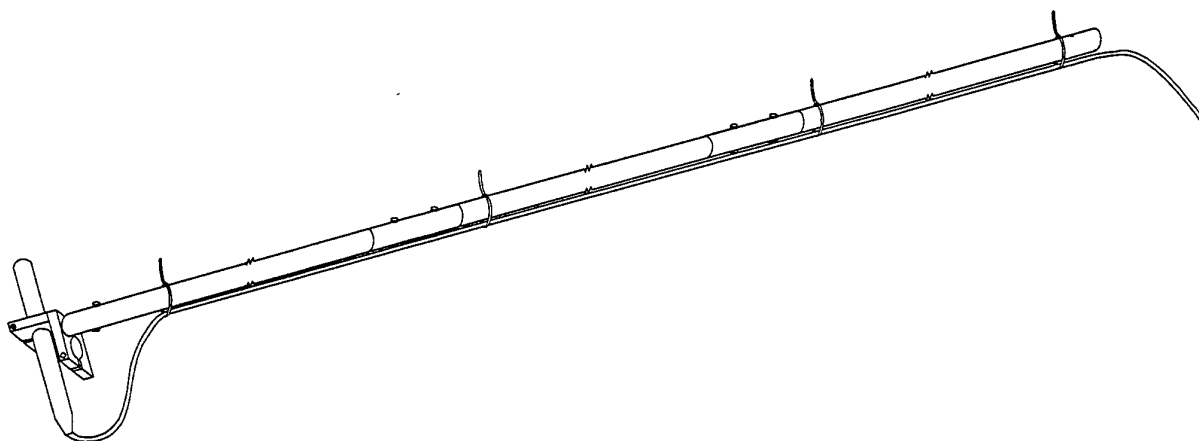

Figure 2. Extension pole assembled with the hydrophone attached in the perpendicular orientation.

To deploy the hydrophone, the pole is simply held vertically over the side of a boat. As the pole is light, there should be little difficulty maintaining the vertical orientation. The operator should note the direction in which the hydrophone is pointing, and recording can begin.

2.3 Hydrophone

Ambient noise decreases with frequency, often by about 18 dB per decade of frequency. Consequently, the noise which can be measured at high frequencies is low and cannot easily be measured with most hydrophones. For example, ITC makes two omni-directional models, the 6050 and 6080, but their response falls off sharply above 75 and 55 kHz, respectively. Their omni-directional model 1089 operates to 300 kHz, but unfortunately has quite a low sensitivity. To gain sufficient sensitivity it is necessary to use a hydrophone which becomes increasingly directional at higher frequencies.

Two hydrophones have been provided, both ITC 8257 models, with serial numbers of 265 and 266. They have integral preamplifiers and are very sensitive, but are directional. Hence, the importance, noted above, of recording the direction in which the hydrophone is pointing when attached to the pole and deployed over the side of a boat. This directionality has the advantage, however, of providing an estimate of the directionality of the sea noise.

Figure 3 shows the sensitivity curves of the two hydrophones. These were measured at Woronora Dam. They have been digitised and incorporated into the Matlab analysis software (see below). The beam patterns at 10, 50, 80 and 150 kHz shown in Figure 4 were provided by the manufacturer. They have been used to

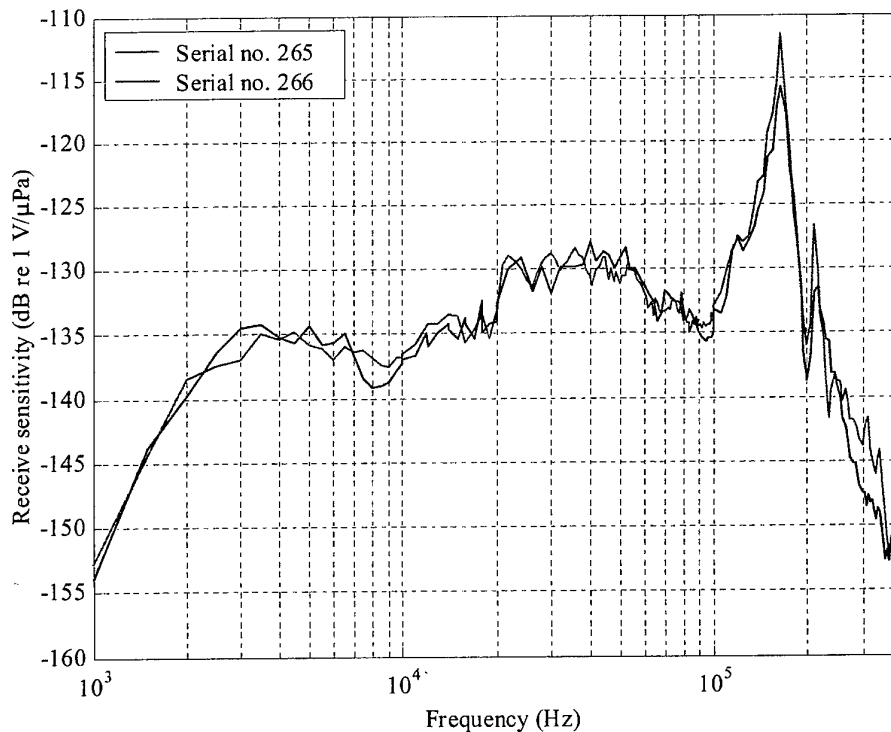

Figure 2. Sensitivity curves for the ITC 8257 hydrophones.

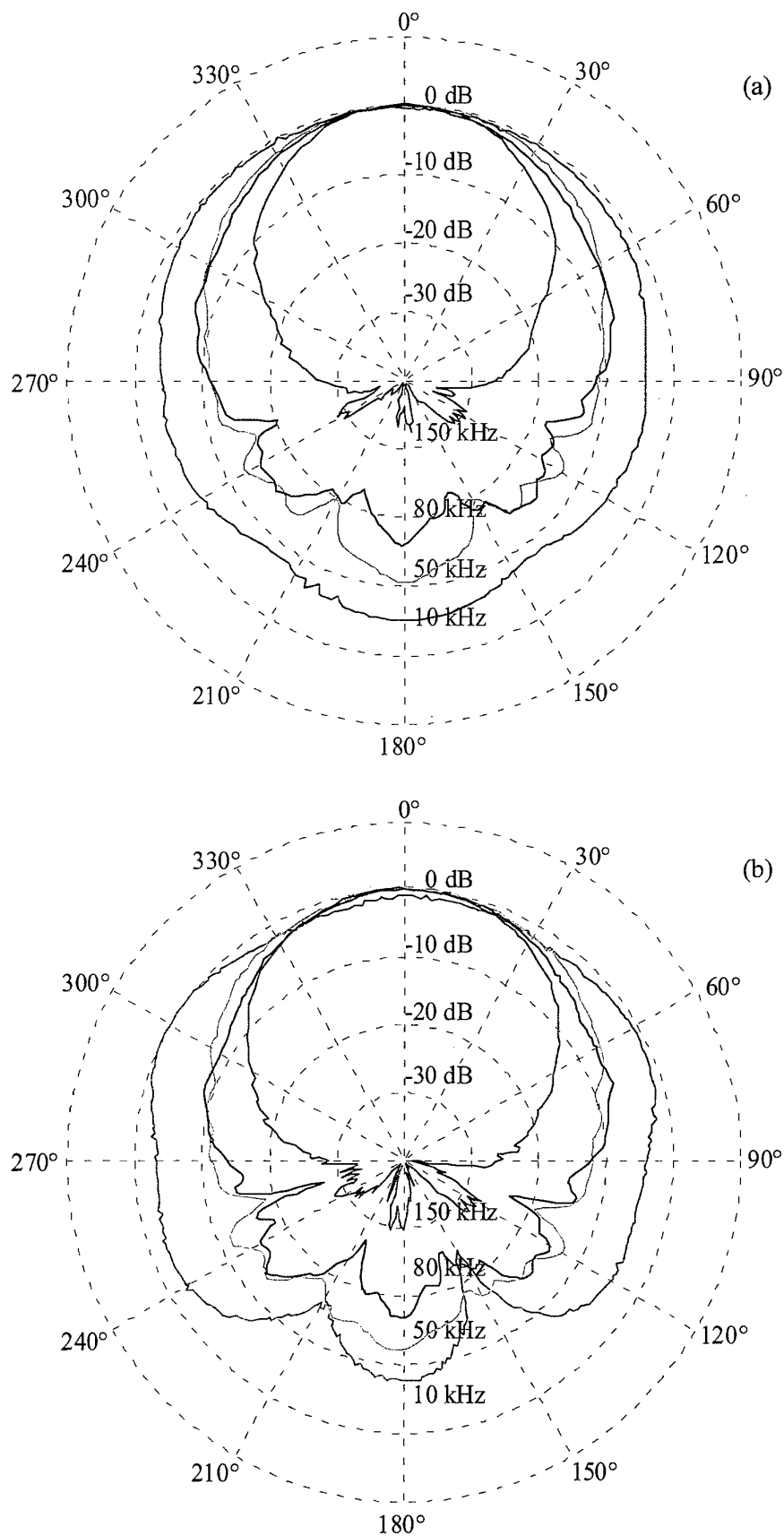

Figure 4. Beam patterns of the ITC 8257 hydrophones, a) serial number 265; b) serial number 266.

calculate a conversion to what would be measured with an omni-directional hydrophone, but the correction is only approximate above 100 kHz.

Parameters affecting the lowest ambient noise which can be measured with a hydrophone include its sensitivity and the input noise of any preamplifier. Due to the high sensitivity of the ITC 8257 and the performance of the components used in the preamplifier, this model hydrophone can record quite low ambient noise levels, at least to 200 kHz. At higher frequencies its performance degrades. Figure 5 shows the lowest levels which can be measured up to 350 kHz. Although the hydrophone can be used above 200 kHz, for ambient noise measurements the signal will frequently be below this noise floor, so that part of a spectrum calculated above 200 kHz may be in error. Unless the ambient noise is at least 10 dB above the noise floor shown in Figure 5, a correction must be made to remove the contribution of amplifier noise (see Appendix).

An ITC 8257 hydrophone requires 25 mA at +15 V to power the preamplifier. This is provided by a power supply containing 10 D-cells soldered together. These batteries should provide about 400 hours of power. As the D-cells become exhausted and the voltage from the power supply drops, the hydrophone will continue to operate, but its preamplifier gain will drop significantly once the voltage has fallen below 12 V. As this will result in measurement errors, the batteries should be replaced before this stage is reached, preferably by the time the voltage has fallen to 13 V. The battery voltage can be measured at the white (positive) and black (negative) test points, but should be done under load, i.e. with the hydrophone plugged in and the power supply switched on.

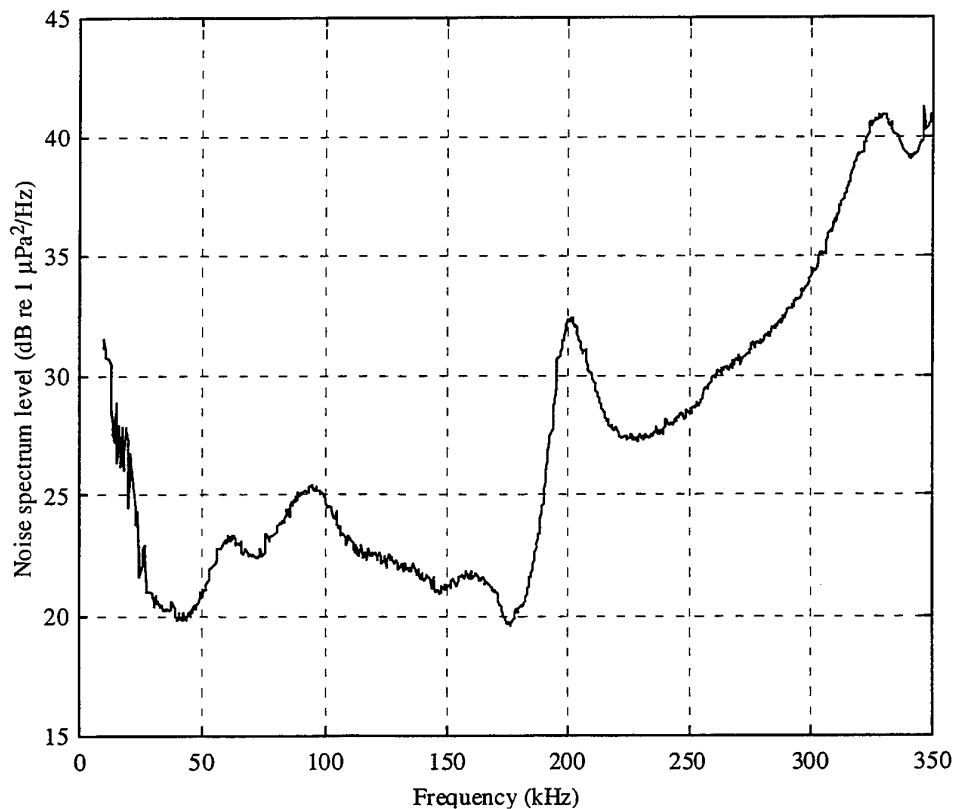

Figure 5. Lowest ambient noise level which can be measured by an ITC 8257 hydrophone in water.

To operate the hydrophone simply plug the 5-pin XLR connector at the end of the cable into its mate on the side of the power supply box and turn the switch on. To conserve battery life, only switch on when recording data. The output signal from the hydrophone is available via the BNC connector, also on the side of the power supply box.

2.4 Analogue to digital conversion

Analogue to digital conversion is achieved with an Iotech WaveBook/512 system. This provides up to 1 MHz sampling with 12-bit resolution. To increase sample size at the fast conversion rates, 128 MB of internal RAM has been installed. Although the WaveBook has eight input channels, usually only one will be used to record the high frequency spectra. The coaxial cable from the hydrophone power box should be plugged into the "Ch1" BNC socket on the side panel at the front.

The WaveBook can be powered from the mains by using the small AC power adaptor (model number TR9CG2700N05-AI), however it should not be powered from the mains for data recording. The power adaptor is a switchable type and emits switching spikes throughout the frequency range of interest. These electromagnetic emissions will be picked up by the cables and superimposed on the ambient noise signal from the water. This will unnecessarily complicate the data collection.

For recording data, the WaveBook should be powered by the DBK30A rechargeable battery module. A short cable with 5-pin DIN connectors on either end is provided for this purpose. This should be connected from the "power out" socket of the DBK30A to the "power in" socket of the WaveBook.

When fully charged, the DBK30A can power the WaveBook for about 3 hours. The DBK30A itself can be charged with the AC power adaptor (model number PSA242) plugged into its "power in" socket on the side panel at the back of the WaveBook. The DBK30A should take about 2 hours to charge, but again this should not be done when recording data.

2.5 Computer storage

The signal from the WaveBook goes to a Mitac 6033 notebook computer via a WBK20 PC Card to Parallel Port Adaptor. This card is inserted into one of the computer's Type II PC-Card sockets on the left-hand side panel of the computer, with the label facing upwards. The cable joining the WaveBook to this card has a 25-pin D connector on one end and a small edge connector on the other end. The D connector plugs into the "to computer" socket on the WaveBook, with the edge connector locking onto the WBK20 card.

The maximum transfer rate from the WaveBook to the Mitac computer is approximately 447 k samples/s. Although the card can transfer at more than twice this rate, the bottleneck is in the transfer from the Type II PC socket to computer BUS. At acquisition rates of less than 447 k samples/s, data can be collected continuously, until the hard disk fills up. At higher sample rates data is stored in the extra 128 MB of memory inserted into the WaveBook. At the maximum sample rate of 1 M samples/s, approximately 60 seconds of data can be collected, at 2 bytes/sample, before this memory is full. The data is then transferred at 447 k samples/s into the computer. Thus at 1 M samples/s, 60 seconds is the maximum period of time over which data can be collected.

As the data is collected it is transferred to the computer's 6 GB hard disk. At high data rates this hard disk will soon fill up, so the data can be downloaded to a 2 GB Jaz disk. The Jaz drive is powered by its own AC power adaptor (again this should be turned off when data recording is in progress). The data is transferred via a Jaz PCMCIA to Fast SCSI II Adaptor, which is inserted into the computer's other Type II PC-Card socket on the left-hand side panel of the computer. The cable joining this card to the drive also has a small edge connector which connects to the card. The SCSI connector on the other end of the cable connects to the Jaz drive.

The computer can be run off the mains with the included AC power adaptor, but this should not be done when recording data, for the same reasons as outlined above for the WaveBook's AC power adaptor. Likewise, an external monitor should not be used, as this too will add unwanted electromagnetic interference. If an external monitor must be used, say because the built-in monitor is hard to see in sunlight, it should be turned off as soon as possible after data collection has commenced, and only turned back on when it is certain that the data acquisition has been completed.

3. SOFTWARE

3.1 Software overview

The WaveBook is set up via a utility called "Daq Configuration" and data acquisition is controlled through a Windows program called "WaveView". This initialises the WaveBook, controls the collection and transfer of data to the computer, and stores it on hard disk. WaveView can store the data in various formats. If stored in one particular format, the data can be viewed with "PostView", which enables the time traces to be seen. If stored in binary the data can be analysed with two programs written in "Matlab", WbkSpectra.m and WbkSnap.m. One of these calculates the spectrum over an extended sample of data; the other displays a short sample of data and calculates its corresponding spectrum.

3.2 Daq Configuration

When the WBK20 PC Card to Parallel Port Adaptor was installed on the computer, software was added to allow configuration of the data transfer to the computer. Within Windows 98's "Start>Settings>Control Panel" is this utility, "Daq Configuration". The "Add Device" button was used to add a WaveBook, which is listed in the Device Inventory as "WaveBook 0". Highlighting WaveBook 0 and pressing the "Properties" button, the Device Settings are seen to have been set up as

Device Name	WaveBook 0
Device Type	WaveBook
Parallel Port	LPT2
Protocol	Fast EPP (wbk/20/21)

To check that the hardware is functioning correctly with the WaveBook switched on and connected to the computer, the "Test Hardware" tab can be chosen, followed by the "Resource Test" button. A dialogue box will ask confirmation that the device is properly configured, connected and powered on before proceeding. After pressing "Yes", there will be a delay of a few seconds. If all is functioning normally the "Test Results" will be filled in with

Resource Tests

Base Address Test → Passed

Performance Tests

Adc Fifo Input Speed → 447xxx samples/sec

where the three digits represented by "xxx" will vary slightly from one test to another. The speed of approximately 447 ksamples/sec is achieved with the Mitac 6300 notebook. Other computers will achieve different transfer rates. For example, a Toshiba Tecra500CDT can transfer 417 ksamples/sec.

If the hardware was not functioning correctly, because, for example, the WaveBook was switched off, when the "Resource Test" button was selected, the "Test Results" will quickly return "Error – Could not open device".

When the testing is successful, not only do the above test results appear, but a button labelled "WBK30 FIFO Test" appears next to the "Test Hardware" button. Although not normally tested, the "WBK30 FIFO Test" button can also be selected to test the extra 128 MB memory added to the WaveBook. As the resultant dialogue box notes, the test can take up to 8 minutes, so after confirming a desire to proceed, and waiting several minutes, the "Test Results" will be filled in with

WBK30 FIFO Test → Passed

3.3 WaveView

The data acquisition software is accessed through "Programs>WaveBook Software>WaveView 7.3". If functioning correctly the window shown in Figure 6 should appear after a few seconds. It is important that "WaveView – WAVEVIEW.CFG (WaveBook 0)" appear across the window title. If instead "WaveView – WAVEVIEW.CFG (Simulation Only)" appears, go to the "System>Select Device..." menu and choose "WaveBook 0" from the "Device Inventory".

If instead of starting seamlessly, the error message "No device at specified port (AttReal)" appears, hit "OK". The next window to appear has the title "WaveViewStartUp" and the message "Cannot make connection to the device WaveBook 0". Choose the "Retry" button. More than one attempt may be necessary before success is attained. Continual failure will correspond to the "Resource Test" of the "Daq Configuration" utility also failing. This failure is usually due to the WaveBook not being switched on, or the cable between the WaveBook and computer being loose.

Within "WaveView – WAVEVIEW.CFG (WaveBook 0)" the "Channel Configuration" should be set so that channel 1 is "On" with a range of "-5.0 to 5.0V". All other channels should be "Off".

Several options can be set in "System>Options...":

1. Under the "Performance" tab "Use data packing" should be selected. The defaults of "Factory Calibration Table" and use of the "Total memory in your computer (MB)" should also be used.

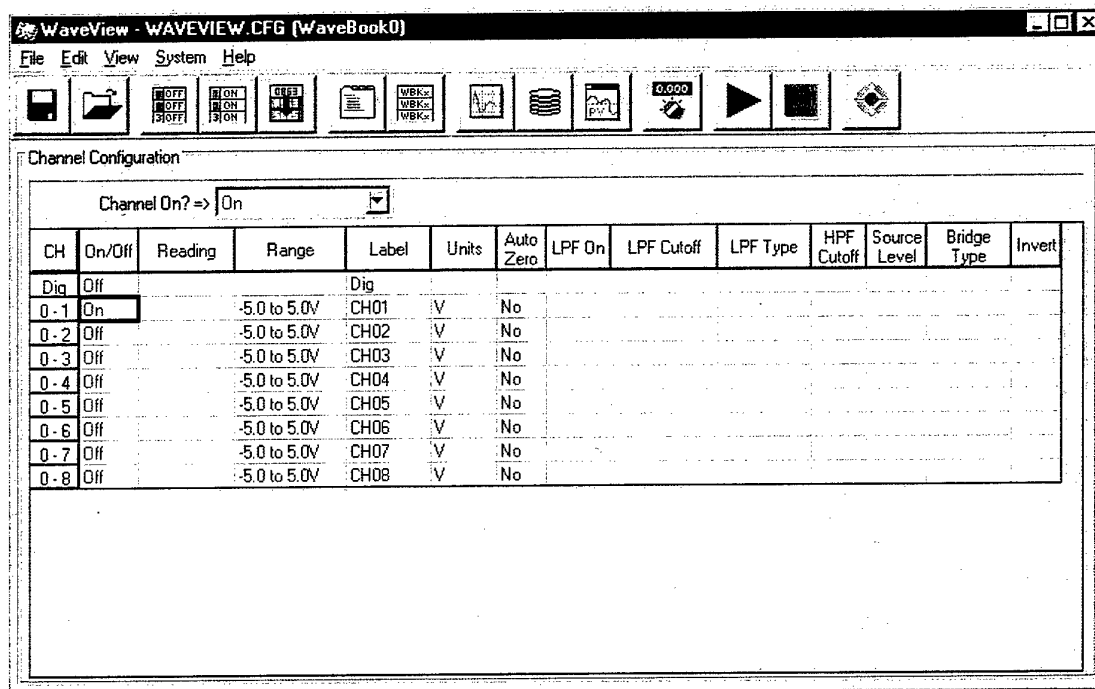

Figure 6. WaveView configuration screen display.

- Under the "Data Files" tab, normally only the "Raw Binary" "Data Format" should be selected. This provides the fastest data collection. Although the subsequent data analysis is done with Matlab, don't select the "Matlab" data format, as this is slow, wastes hard disk space and the analysis programs have been written to use raw binary data anyway. If PostView (see below) is to be used, mainly to quickly look at the sinusoidal voltage signal, the "PostView Binary" data format should also be selected. However, this should not be selected if PostView is not going to be used, as again it slows down the data acquisition and wastes hard disk space. So that the data files are not accidentally overwritten, "Confirm File Replace" is normally selected.
- Under the "Memory Module" tab, the "Pre-Trigger Mode" is not normally selected. "Overflow Protection" is usually enabled.

Details about the data sample rate and the length of the data record are set in "View>Acquisition Configuration". The "Convention" for "Duration" and "Rate" are set to "Seconds" and "Frequency", respectively. The "Pre-Trigger" "Duration" is set to "0 s", whilst the "Post-Trigger" "Duration" is set to the desired sampling time, e.g. "30 s" will collect 30 s of ambient noise data.

To satisfy the Nyquist theorem, the sampling rate is usually set to at least twice the maximum frequency of interest. As noted above, the hydrophones can be used to record spectra to 200 kHz, so the sampling rate should be set to at least twice this rate. A sampling rate of 500 kHz is recommended. Hence both the "Pre-Trigger" and "Post-Trigger" "Rate" should be set to "500 kHz". Note that WaveView does not write this rate into the file and it is essential that it be noted separately by the operator, as the value will be needed for the subsequent analysis.

The "Trigger Source" should be set to "Immediate" so that the commencement of data collection is controlled by the press of a mouse button.

Data collection is initiated through "View>Direct to Disk". The operator should enter a "Filename" and "Base Path" in the "Data Destination" frame. There is no need to add an extension to the file name as this will be added automatically. A suitable base path is "C:\My Documents\Noise Data\ ", although this sub-directory should be created beforehand in the Windows environment. If only raw binary data (recommended) is being collected, the data file will be recorded in the sub-directory "BIN" (short for 'binary') of the base path. This can be seen in the frame detailing the path. The "File Types" button can be used to access the data file types (see above) and add or remove various file types. The sub-directories, such as "POSTVIEW" if "PostView Binary" is selected, will be shown in this path frame.

To start collecting data, use the mouse to click on the green arrow, which acquires one shot. If the file name does not already exist, data collection will commence immediately. If the file name already exists and "Confirm File Replace" was selected in "System>Options>Data Files", a warning message will be displayed. Data collection will only commence when this warning has been attended to.

Upon commencement, the "Current State" will report "Triggered" and the "Number of Scans" will start to increment. After some time the "Current State" will report "Transferring" as data is transferred to the computer. If "PostView Binary" was also selected the "Current State" will also report "Processing" and again confirmation of the file name will be requested if that name already exists.

With data collection underway, the process can be aborted by mouse clicking on the red "Stop" button.

3.4 PostView

If the data was also stored as PostView binary it can be viewed with "PostView". This can be started from the "View>PostView..." menu of WaveView, or from the Windows environment via "Programs>WaveBook Software>PostView". When started for the first time a "Chart Setup Wizard" will be activated. The default will display the "Simple" tab, with "Create 1 Charts with one channel assigned per chart" and "Start with CH01". Hit the "Create Charts" button to create this.

If PostView was invoked from WaveView it will automatically display part of the data file just collected. If started from the Windows environment it will display a dialogue box asking for the name of the file to open.

The voltage trace will be displayed, and this can be scrolled through using the slider bar at the bottom. A series of buttons on the right control the voltage scale and centre line.

3.5 WbkSpectra.m

PostView is mainly used to view the voltage trace, but cannot be used for spectral analysis. Matlab programs have been provided for this purpose. The main program to use is "WbkSpectra.m". This is invoked from Matlab's command line by typing in "WbkSpectra" and then pressing the "Enter" button. This will produce a GUI (Figure 7) used to control the spectral analysis. Programs which control the GUI

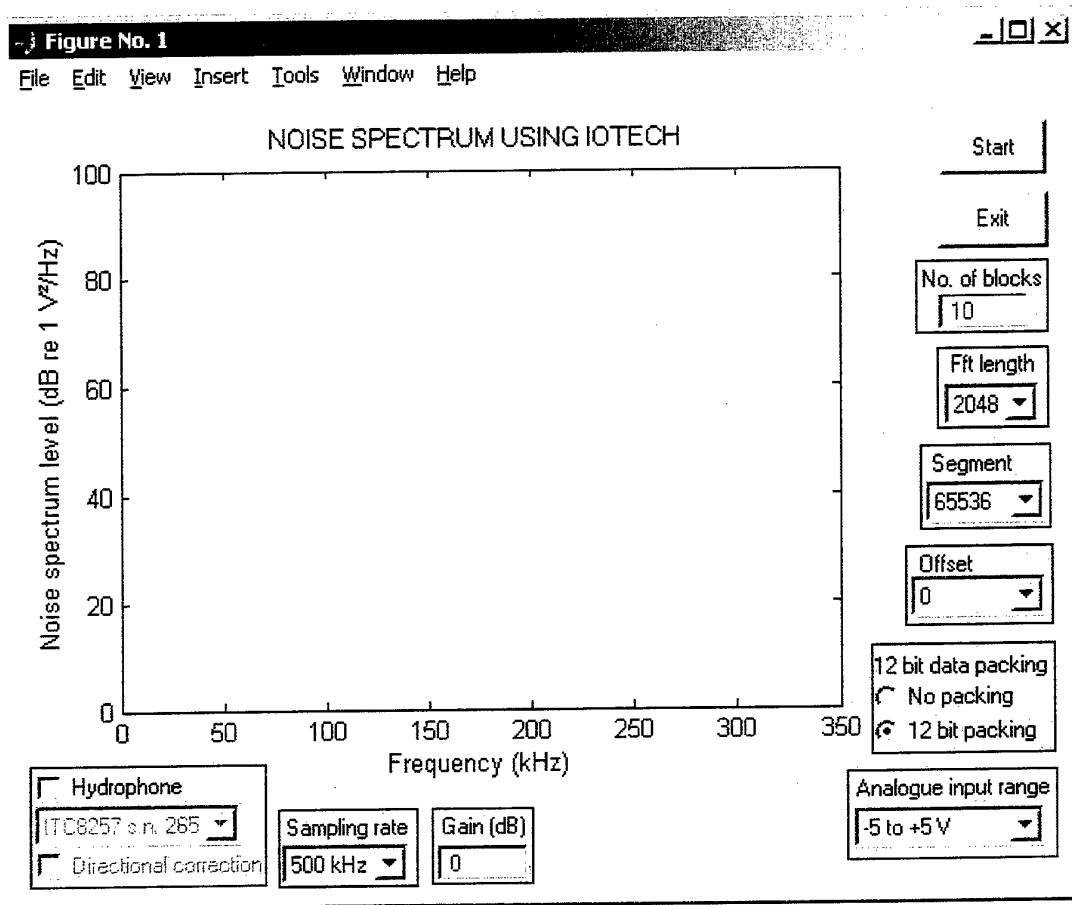

Figure 7. Matlab GUI for WbkSpectra.m

are: WbkSpectra.m, WbkSpectraFig.m, WbkSpectraCallback.m, and WbkSpectraFig.mat.

The abscissa displays the frequency in kHz. The default scale is from 0 to 350 kHz, but this changes to match the frequencies over which the hydrophone has been calibrated and the sampling rate. For example, if the sampling rate was 500 kHz, the scale will run from 0 to 250 kHz.

The default ordinate units are "dB re 1 V²/Hz" in which the 12-bit data is taken from the raw binary data file, converted to volts and then the noise spectrum level calculated from this. By selecting "Hydrophone" the units are converted to a pressure in the water, and are given in "dB re 1 μ Pa²/Hz". If a hydrophone has been selected, two choices are given corresponding to the two ITC 8257 hydrophones. That with the appropriate serial number should be selected, so that the correct calibration is used in the conversion from a voltage to a pressure. A directional correction can also be incorporated to convert the spectrum levels to that which would be recorded by an omni-directional hydrophone, but as noted above, this is only approximate.

The default sampling rate is "500 kHz", but this should be changed, if required, to match the sampling rate used when recording the data with WaveView. The gain will usually be the default of "0 dB", unless an extra amplifier was inserted between the hydrophone and the WaveBook. The "Analogue input range" should match that used with WaveView, which will normally be the default of "-5 to +5 V". The default

data packing regime is "12 bit packing" which will match that which was selected under WaveView's "System>Options>Performance" tab.

The "Offset" refers to where in the data, processing should commence. Usually this will be "0", corresponding to the first bit of data, but two delayed offsets are provided if the first section of data should be avoided. The most likely reason is that an electronically noisy piece of equipment, such as a cathode ray tube monitor, was used in place of the laptop's monitor and was turned off after the acquisition began so as to reduce electromagnetic interference.

When satisfied with the input parameters, the "Start" button can be pushed. This calls up a dialogue box from which the appropriate binary data file can be selected. When one has been chosen, hit the "Open" button and the program starts to read data from the selected file.

The spectrum is calculated using Welch's method of averaging modified periodograms (Welch, 1970; Oppenheim and Schafer, 1975: 553). The "Segment" of data points is split into smaller portions, windowed with a Hanning window, and fast Fourier transformed with "Fft length"-point FFTs with 50% overlap to provide multiple spectra, which are averaged. The default segment size of "65536" and fft length of "2048" produce satisfactory results. At a sampling rate of 500 kHz this corresponds to just 0.13 s of data, so further averaging is required. This is achieved by averaging over several blocks of contiguous data segments. For example, by selecting the "No. of blocks" to be "10", averaging is over a total data record of 1.3 s in the above example. This is satisfactory for a quick analysis, but a block size of "100", or 13 s of data, is needed to produce relatively smooth spectra.

The spectrum can be printed out using the figure window's "File>Print" menu. The standard Windows set up and options apply. Some of the printing options are also configured in "File>Preferences...", by selecting the "Figure Copy Template".

The "Exit" button is used to exit from the program, but clicking on the figure window's "X" button will also close the program.

3.6 WbkSnap.m

A second Matlab program, 'WbkSnap.m', is provided to allow spectral analysis of selected sections of the recording. This is also invoked from Matlab's command line by typing in "WbkSnap" and then pressing the "Enter" button. Again a GUI (Figure 8) is produced to control the spectral analysis. Programs which control the GUI are: WbkSnap.m, WbkSnapFig.m, WbkSnapCallback.m, and WbkSnapFig.mat. Most of the edit boxes and buttons are the same as for WbkSpectra.m, but this time two graphical windows are displayed. The upper graph displays the sinusoidal voltage trace of the segment of data; the lower graph displays its corresponding spectrum, calculated as described above.

To select the appropriate data file, the "Start" button is again clicked on. The first segment of data, after the offset, is read from the file and displayed in the upper graph. Its spectrum is calculated and displayed on the lower graph. The mouse can be used to zoom in on part of the voltage trace, and by left-clicking the mouse on the grey background area outside the graphs, the spectrum corresponding to that portion is displayed in the lower graph. The zooming and recalculation of the spectrum can be repeated several times. This zooming feature is particularly useful for looking at short voltage transients, such as snaps from snapping shrimp.

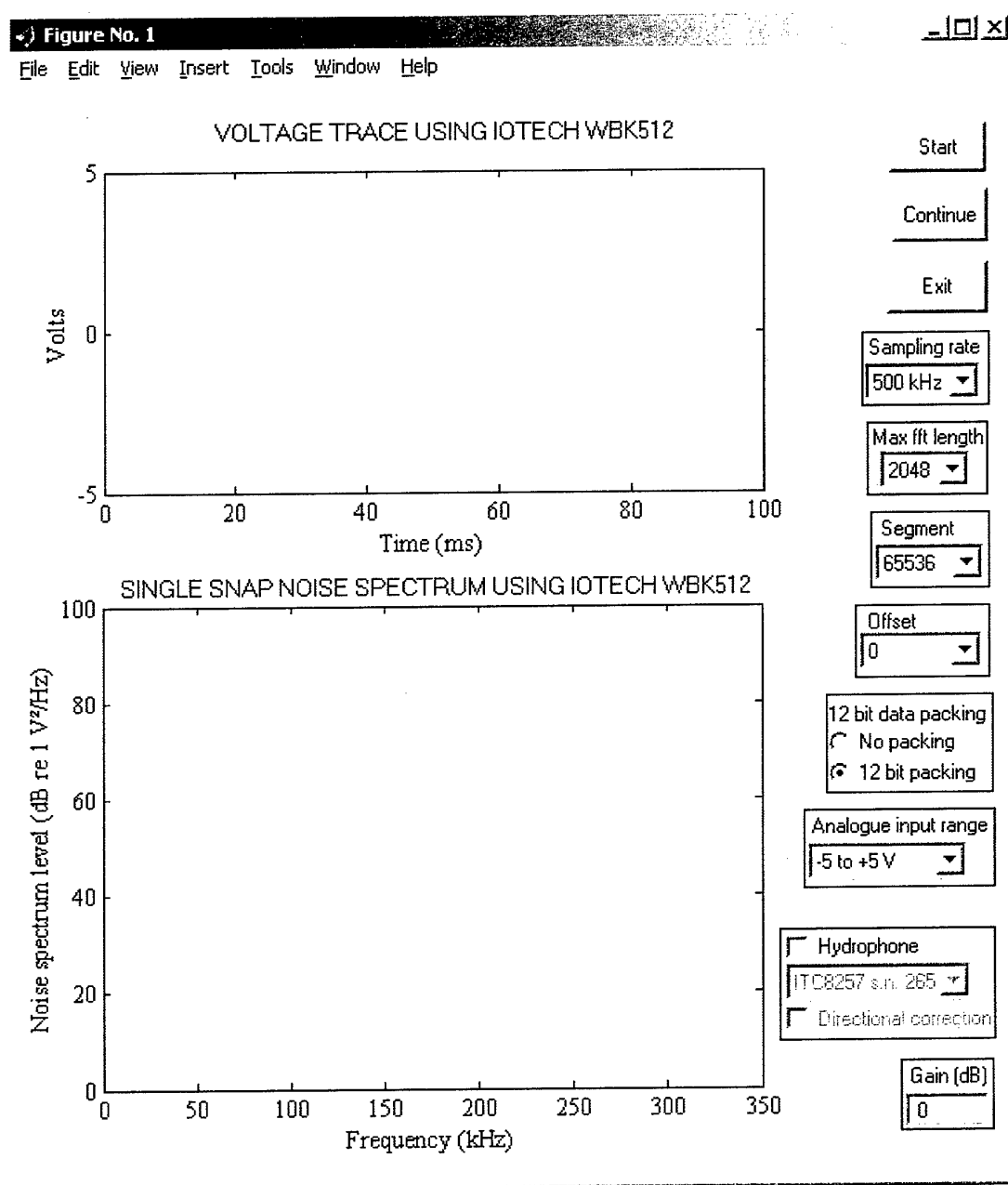

Figure 8. Matlab GUI for WbkSnap.m

When finished with a segment of data, the "Continue" button is used to move on to the next segment of data, and zooming can commence again. To exit from the program, use either the "Exit" button or the window's "X" button.

4. REFERENCES

- Oppenheim, A.V., and Schaffer, R.W. (1975). *Digital signal processing*, Prentice-Hall, Englewood Cliffs, N.J., 585 pp.
- Welch, P.D. (1970). "The use of fast Fourier transform for the estimation of power spectra: a method based on time averaging over short, modified periodograms", *IEEE Trans. Audio Electroacoust.*, **AU-15**, 70-73.

5. APPENDIX

In section 2.3 it was noted that for frequencies above 200 kHz the sea noise spectral levels may be close to the noise floor of the hydrophone and its preamplifier, shown in Figure 5. For all frequencies for which the ambient noise does not exceed this noise floor by at least 10 dB, the following correction is required.

In essence the mean square noise voltage output by the hydrophone should be subtracted from the ambient sea noise voltage recorded, prior to conversion to the dB scale. Thus the corrected ambient sea noise spectral level is

$$10 \log(\bar{V}_{sn}^2 - \bar{V}_{hn}^2)$$

where \bar{V}_{sn}^2 is the mean square ambient sea noise voltage and \bar{V}_{hn}^2 is the mean square noise from the hydrophone/preamplifier itself. Since WbkSpectra.m and WbkSnap.m output spectral levels in dB and the noise floor shown in Figure 5 is in dB,

$$10 \log\left(10^{SN/10} - 10^{HN/10}\right)$$

is more convenient to use. In this case SN is the sea noise level calculated by WbkSpectra.m or WbkSnap.m, in dB, and HN is the hydrophone noise floor shown in Figure 5, also in dB.

DISTRIBUTION LIST

Instruction Manual for Ultrasonic Noise Recording System

Mark L. Readhead

AUSTRALIA

DEFENCE ORGANISATION

Task Sponsor

Chief Maritime Operations Division

S&T Program

Chief Defence Scientist }
FAS Science Policy } shared copy
AS Science Corporate Management }
Director General Science Policy Development }
Counsellor Defence Science, London (Doc Data Sheet)
Counsellor Defence Science, Washington (Doc Data Sheet)
Scientific Adviser to MRDC Thailand (Doc Data Sheet)
Scientific Adviser Policy and Command
Navy Scientific Adviser (Doc Data Sheet and distribution list only)
Scientific Adviser - Army (Doc Data Sheet and distribution list only)
Air Force Scientific Adviser
Director Trials

Aeronautical and Maritime Research Laboratory

Director
Research Leader Mine Warfare
Dr Doug Cato
Dr Mark Readhead

DSTO Library and Archives

Library Fishermans Bend (Doc Data Sheet)
Library Maribyrnong (Doc Data Sheet)
Library Salisbury
Australian Archives
Library, MOD, HMAS Stirling
Library, MOD, Pyrmont
US Defense Technical Information Center, 2 copies
UK Defence Research Information Centre, 2 copies
Canada Defence Scientific Information Service, 1 copy
NZ Defence Information Centre, 1 copy
National Library of Australia, 1 copy

Capability Systems Staff

Director General Maritime Development (Doc Data Sheet only)
Director General Aerospace Development (Doc Data Sheet only)

Knowledge Staff

Director General Command, Control, Communications and Computers (DGC4) (Doc Data Sheet only)
Director General Intelligence, Surveillance, Reconnaissance, and Electronic Warfare (DGISREW)R1-3-A142
CANBERRA ACT 2600 (Doc Data Sheet only)
Director General Defence Knowledge Improvement Team (DGDKNIT) R1-5-A165, CANBERRA ACT 2600 (Doc Data Sheet only)

Army

Stuart Schnaars, ABCA Standardisation Officer, Tobruck Barracks, Puckapunyal, 3662 (4 copies)
SO (Science), Deployable Joint Force Headquarters (DJFHQ) (L), MILPO Gallipoli Barracks, Enoggera QLD 4052 (Doc
Data Sheet only)

Intelligence Program

DGSTA Defence Intelligence Organisation
Manager, Information Centre, Defence Intelligence Organisation

Corporate Support Program

Library Manager, DLS-Canberra

UNIVERSITIES AND COLLEGES

Australian Defence Force Academy
Library
Head of Aerospace and Mechanical Engineering
Librarian, Flinders University

OTHER ORGANISATIONS

NASA (Canberra)
AusInfo

OUTSIDE AUSTRALIA**ABSTRACTING AND INFORMATION ORGANISATIONS**

Library, Chemical Abstracts Reference Service
Engineering Societies Library, US
Materials Information, Cambridge Scientific Abstracts, US
Documents Librarian, The Center for Research Libraries, US

INFORMATION EXCHANGE AGREEMENT PARTNERS

Acquisitions Unit, Science Reference and Information Service, UK
Library - Exchange Desk, National Institute of Standards and Technology, US

ROYAL THAI NAVY

Capt Witoon Tantigun, Director, Oceanographic Division, Hydrographic Dept, Royal Thai Navy, Bangkok 10600,
Thailand
Lt Siriwat Siriwatanakul, Oceanographic Division, Hydrographic Dept, Royal Thai Navy, Bangkok 10600, Thailand
Lt Pannart Nakbubpa, Oceanographic Division, Hydrographic Dept, Royal Thai Navy, Bangkok 10600, Thailand

SPARES (5 copies)

Total number of copies: 46

DEFENCE SCIENCE AND TECHNOLOGY ORGANISATION DOCUMENT CONTROL DATA				1. PRIVACY MARKING/CAVEAT (OF DOCUMENT)			
2. TITLE Instruction Manual for Ultrasonic Noise Recording System			3. SECURITY CLASSIFICATION (FOR UNCLASSIFIED REPORTS THAT ARE LIMITED RELEASE USE (L) NEXT TO DOCUMENT CLASSIFICATION) Document (U) Title (U) Abstract (U)				
4. AUTHOR(S) Mark L. Readhead			5. CORPORATE AUTHOR Aeronautical and Maritime Research Laboratory PO Box 4331 Melbourne Vic 3001 Australia				
6a. DSTO NUMBER DSTO-GD-0285		6b. AR NUMBER AR-011-857		6c. TYPE OF REPORT General Document		7. DOCUMENT DATE April 2001	
8. FILE NUMBER 490-6-94	9. TASK NUMBER REN 99/036		10. TASK SPONSOR CMOD		11. NO. OF PAGES 14	12. NO. OF REFERENCES 2	
13. URL ON THE WORLD WIDE WEB http://www.dsto.defence.gov.au/corporate/reports/DSTO-GD-0285.pdf			14. RELEASE AUTHORITY Chief, Maritime Operations Division				
15. SECONDARY RELEASE STATEMENT OF THIS DOCUMENT <i>Approved for Public Release</i>							
OVERSEAS ENQUIRIES OUTSIDE STATED LIMITATIONS SHOULD BE REFERRED THROUGH DOCUMENT EXCHANGE, PO BOX 1500, SALISBURY, SA 5108							
16. DELIBERATE ANNOUNCEMENT No Limitations							
17. CASUAL ANNOUNCEMENT Yes							
18. DEFTTEST DESCRIPTORS Underwater ambient noise, ultrasonic frequencies, spectrum analysis							
19. ABSTRACT A portable system for recording ambient noise in the sea has been developed. It is suitable for ultrasonic frequencies and can digitise up to a rate of 1 MHz. The hydrophone is attached to the end of a light weight aluminium pole of 4.5 m extension, which can be dismantled into 1.5 m lengths for ease of transport. The hydrophone has an integral preamplifier which is powered by batteries. The analogue to digital conversion is performed in a box with similar dimensions to a laptop computer. It is powered by another similarly-sized box of rechargeable batteries. The process is controlled by and the data is stored on a laptop computer. Software has been written to display the spectra of the ambient noise. Instructions on the use of the hardware and software are provided.							

