

61918 P

NASA TECHNICAL NOTE

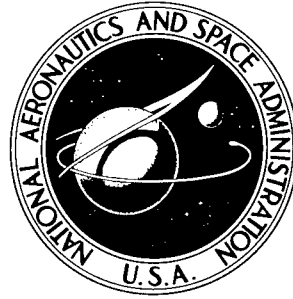

NASA TN D-2949

NASA TN D-2949

PROPERTY OF:

DISTRIBUTION STATEMENT A
Approved for Public Release
Distribution Unlimited

**STRENGTH COMPARISON OF FLAWED
SINGLE-LAYER AND MULTILAYER AISI 301
STAINLESS-STEEL PRESSURE VESSELS
AT CRYOGENIC TEMPERATURES**

by William S. Pierce

*Lewis Research Center
Cleveland, Ohio*

20010720 154

NASA TN D-2949

STRENGTH COMPARISON OF FLAWED SINGLE-LAYER AND
MULTILAYER AISI 301 STAINLESS-STEEL PRESSURE
VESSELS AT CRYOGENIC TEMPERATURES

By William S. Pierce

Lewis Research Center
Cleveland, Ohio

NATIONAL AERONAUTICS AND SPACE ADMINISTRATION

For sale by the Clearinghouse for Federal Scientific and Technical Information
Springfield, Virginia 22151 - Price \$1.00

STRENGTH COMPARISON OF FLAWED SINGLE-LAYER AND MULTILAYER AISI 301 STAINLESS-STEEL PRESSURE VESSELS AT CRYOGENIC TEMPERATURES

by William S. Pierce
Lewis Research Center

SUMMARY

5/1/67
An experimental investigation was conducted to determine the strengths of single-layer and multilayer scale model tanks of AISI 301 stainless steel containing sharp notches and having the same total wall thickness. Material was used for both the single-layer and multilayer tanks having 60- and 70-percent cold reduction. The tanks were pressurized to burst at -320° and -423° F. Smooth, sharp-edge-notch, and sharp-center-notch tensile specimens were tested to provide data for correlation with the tank strengths. The results indicate that an increase of burst stress of approximately 15 to 20 percent for the flawed multilayer tanks can be obtained relative to the comparable single-layer flawed tanks. Three multilayer tanks exhibited failure of the outer layer prior to complete tank failure. This characteristic could provide a fail-safe type of design. Although the multilayer method of construction reduced the notch sensitivity in the tanks, the more notch-ductile 60-percent cold-reduced material was still found to permit higher burst strengths than the 70-percent cold-reduced material where there was a sharp notch in the tank wall.

INTRODUCTION

The importance of weight reduction of the propellant tanks and other pressurized structures of space vehicles has led to a highly concentrated effort to find materials that have a maximum usable strength to weight ratio. Materials in themselves, however, are not the only factor to be considered in designing for light weight. Higher structural strengths can also be obtained with the same materials through ingenuity in design and fabrication techniques. One such method that has been considered is that of producing a tank having walls composed of a number of layers of thin metal sheet (ref. 1). The possibility of a critical flaw existing in more than one layer in the same position would be

remote. If a crack started to propagate, the propagation could not continue through the entire wall thickness but would be restricted to a single layer. In addition, the local area around the crack could be relieved, and the resultant load could be transferred or shifted to the other layers before the critical crack length had been experienced. Thus, one advantage of multilayer wall construction appears to be the increased resistance to crack propagation. A further advantage of a multilayer approach could be a possible improvement in the resistance of structures to manmade surface flaws, such as tool marks and scratches, which probably would exist only on the surface of the outer layer. Also, it might be possible to use a higher strength condition (through cold rolling or heat treatment) of the same material in a thinner gage for the multilayer tank than could be readily used in the thicker gage of a single-layer tank. Disadvantages of the multilayer system include complications in the wrapping process and in making satisfactory joints.

Because of the potential advantages of the multilayer system, an experimental investigation was conducted in which scale model tanks were tested to determine the relative strength of single-layer and multilayer tanks containing sharp-notch flaws. The evaluation of the system was carried out at -320° and -423° F because of the current interest in liquids hydrogen and oxygen as propellants. The material was AISI 301 stainless steel in two conditions of cold work (60- and 70-percent cold reduction).

This report presents the results of burst tests of the scale model tanks of both single-layer and multilayer construction at -320° and -423° F. In addition, the results of extensive tensile tests are presented to give smooth, sharp-edge-notch, and sharp-center-notch data for correlating with the tank burst results. A method of correlation (ref. 2), which is a modification of the Irwin approach, is used as the basis for showing the structural strength advantages of the multilayer system in the presence of sharp notches.

APPARATUS AND PROCEDURE

Material

All test specimens were fabricated from the same heat of AISI 301 stainless steel. The material was in the form of 18-inch-wide sheets, 0.0055 and 0.022 inch thick with cold reductions in each thickness of 60 and 70 percent. The chemical analysis showed an alloying content of 0.11 carbon, 1.02 manganese, 0.024 potassium, 0.013 sulfur, 0.38 silicon, 17.43 chromium, 7.21 nickel, 0.49 molybdenum, and 0.16 percent copper.

Tensile Specimens

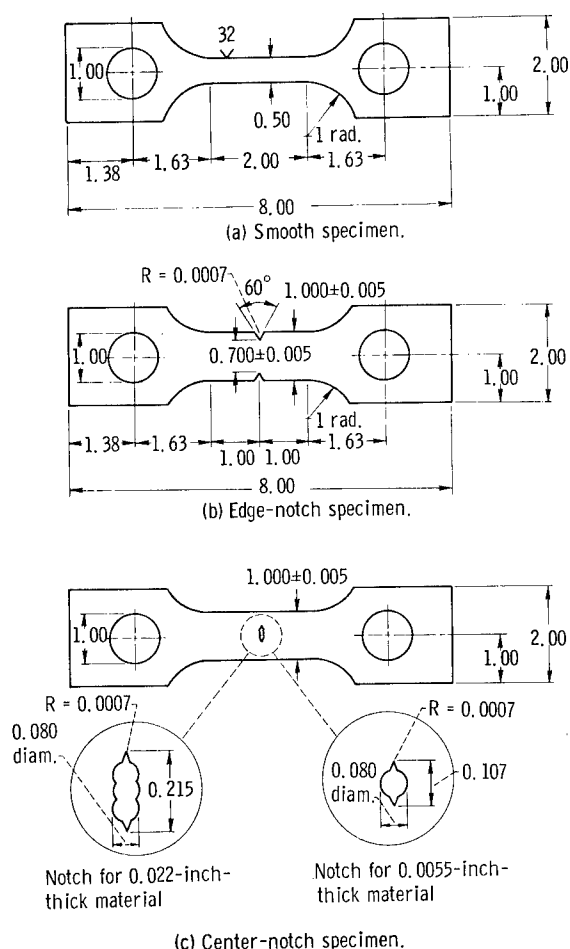

Figure 1. - Tensile specimen configuration. (Dimensions in inches.)

transverse specimens. The longitudinal direction of the tensile specimens corresponds to the hoop direction in the tank specimens. Three specimens were run for each test condition.

Tests were also conducted on specimens containing weld joints. These specimens were fabricated by using the same weld schedule and materials used on the tank specimens. The specimens are shown in figure 2. The specimens of the nominal 0.022-inch-thick material were fabricated by overlapping the sheet material 2.5 inches and spot welding in a chevron pattern. Specimens of the 0.0055-inch material were fabricated in a manner that duplicated the configuration of the joint in the multilayer tanks. These specimens consisted of five layers of 0.0055-inch sheet; the three inner layers extended the full length of the specimen. One of the outer layers extended from one end of the specimen to 1 inch beyond the transverse center line of the joint. The other outer layer extended from the opposite end of the specimen to 1 inch beyond the transverse center line of the joint. The outermost layer and adjacent layer on one side were welded to-

The smooth, sharp-edge-notch, and sharp-center-notch tensile specimen configurations used for this investigation are shown in figures 1(a), (b), and (c), respectively. The data from the edge-notch specimens were included for comparison purposes only and were not used in the analysis. The 0.022-inch material contained machined center notches 0.215 inch in length. The 0.0055-inch material contained 0.107-inch machined center notches. The two notch lengths were selected to correspond with those used in the tanks. The reason for two notch lengths is explained in detail in the section RESULTS AND DISCUSSION. The notch root radius was made as sharp as possible by using conventional machining techniques. This radius was measured and found to be approximately 0.0007 inch for all specimens. The notch configuration was based on that used in reference 2 and was made to correspond with that used in the tank specimens. The notch was oriented normal to the direction of loading in both the longitudinal (rolling direction) and

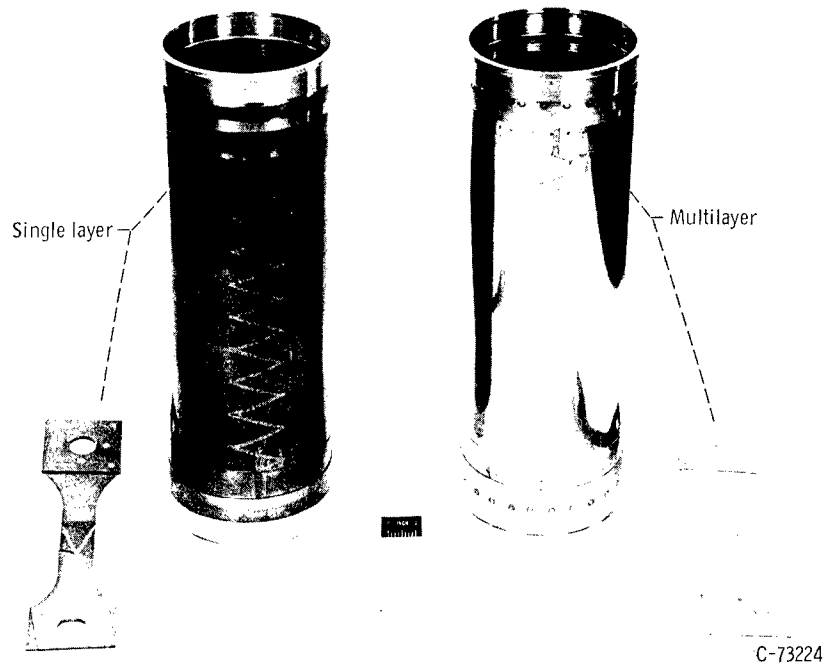

Figure 2. - Single-layer and multilayer AISI 301 stainless-steel test specimens.

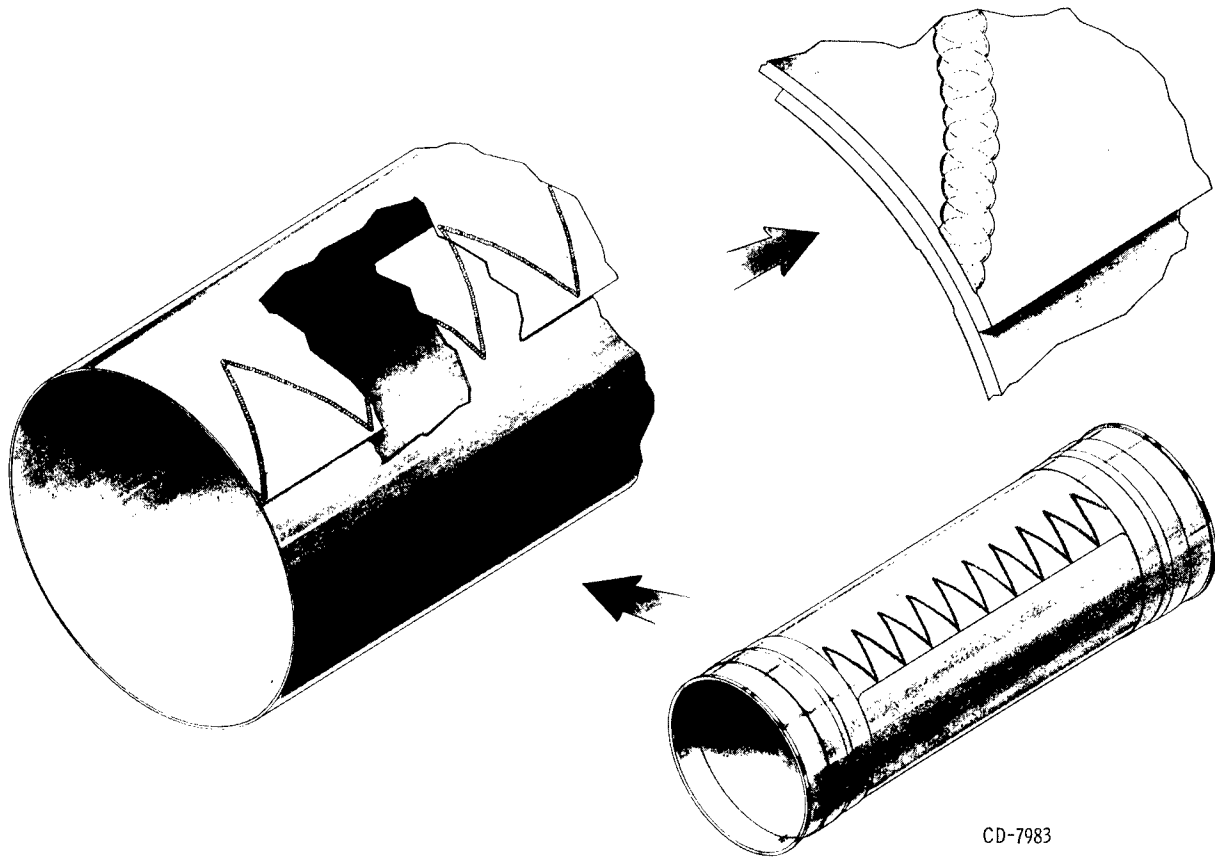
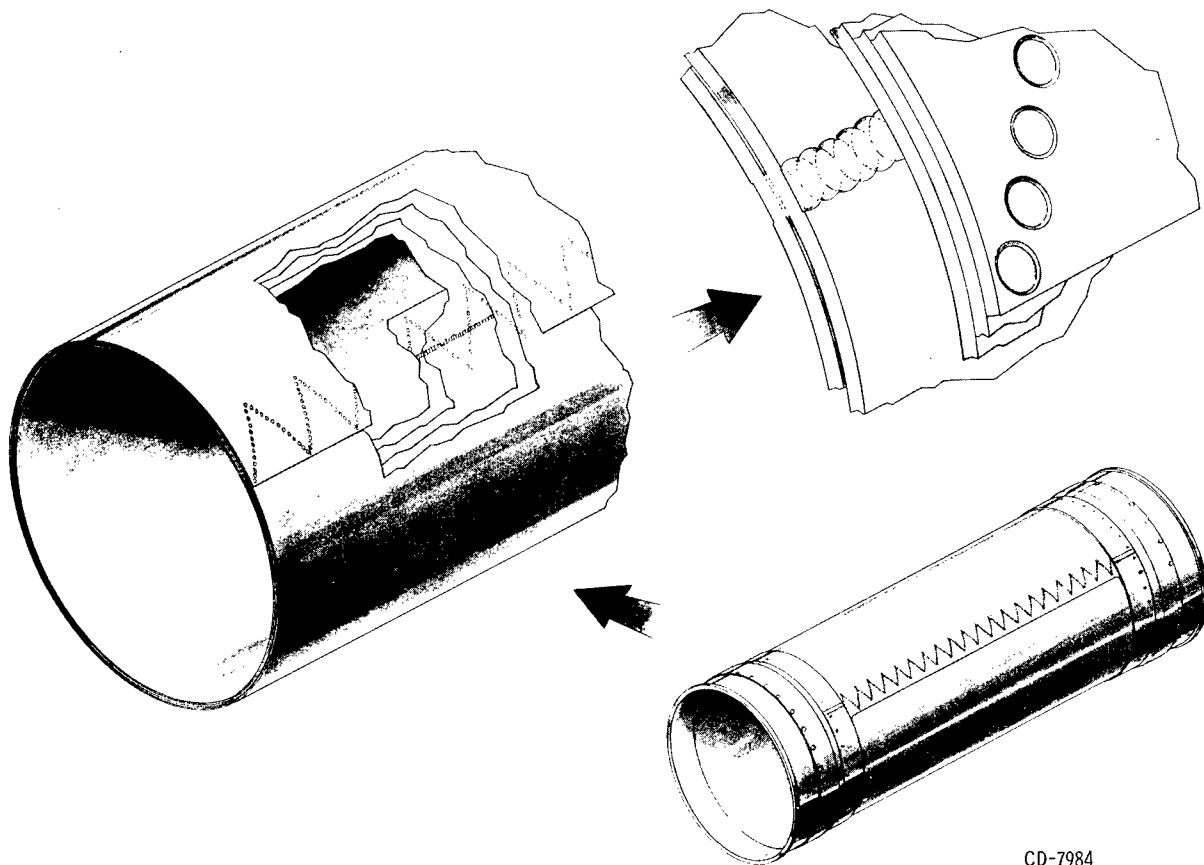

Figure 3. - Single-layer tank construction.



CD-7984

Figure 4. - Multilayer tank construction.

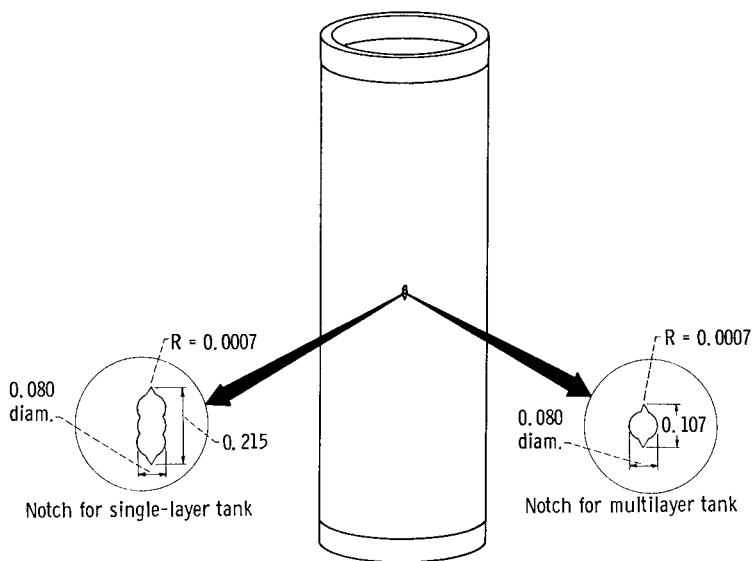

Figure 5. - Notch configuration and orientation in biaxial test specimens. (Dimensions in inches.)

gether with a transverse weld of overlapping spot welds. This procedure was used on the first lap in the tanks to form a pressure seal. In addition, a chevron pattern of spot welds was used to tie all five layers together in a pattern identical to that used in the tank specimen. The weld patterns used for both the single-layer and multilayer tensile specimens were identical to those used in the tank specimens (figs. 3 and 4) discussed in the next section.

Scale Model Tanks

Scale model tanks 6 inches in diameter and 18 inches long were fabricated from the sheet material. The single-layer tanks were 0.022-inch in thickness and were formed by rolling the material into a circular shape and overlapping in a longitudinal joint having an overlapping spot weld pattern as shown in figure 3. The multilayer tanks were constructed of 0.0055-inch-thick material rolled onto a mandrel. The first layer contained a longitudinal seam of overlapping spot welds which acted as a seal. Three more layers were then added. All layers were formed from a single continuous sheet 18 inches wide. At the seam all the layers were tied together by a chevron patterned spot welded joint as shown in figure 4. Special built-up ends were added to all tanks for attachment of removable heads as discussed in reference 3. Figure 2 shows two of the actual tank specimens and their corresponding tensile specimens.

Figure 5 shows the orientation and configuration of the notch in the tank or biaxial test specimen. The notch was oriented in the tank axial direction, which corresponds to the transverse direction of the rolled sheet material. The notches in the single-layer tanks were formed by drilling through with a number 47 drill three overlapping holes and then machining two notches diametrically opposite one another. In the multilayer specimens the notch was placed in the flat sheet prior to the tank fabrication and was located to fall 180° from the weld joint. In this case only one number 47 hole was drilled through the sheet. The resultant 0.107-inch-long notch was through only the outside layer. Three identical specimens were tested at each test condition.

Testing Procedure

Because the biaxial specimens for this study were open-ended cylinders, it was necessary to place special end closures on the cylinders in order to form a complete pressure vessel. This entire unit was then placed in a cryostat and submerged in and filled with either liquid hydrogen or liquid nitrogen depending on the desired test temperature. The vessels or tanks were pressurized to burst using gaseous helium as the pressurizing medium. The through notch in the single-layer tanks was sealed for pressurizing with a composite internal patch consisting of a layer of 0.002-inch Mylar tape, a layer of 0.010-

inch stainless-steel shim, and additional overlapping layers of Mylar tape. It is believed that the patch did not add appreciably to the cylinder strength, nor did it affect the fracture mechanism. P.S.
45

Tests of this type utilizing liquid hydrogen as a test medium require a specially designed facility. A detailed description of the test cell, cryostat, and cylindrical specimen end closures is found in reference 3.

The tensile specimens were tested in a universal testing machine. Strain was measured by using a clamp-on linear-variable differential-transformer extensometer with a 2-inch gage length. The results were obtained on an autographic stress-strain recorder (ref. 4). The specimens were placed inside a cryostat and submerged in the cryogenic fluid to obtain the desired test temperature.

BASIS OF DATA ANALYSIS

Because two notch lengths were involved and the material properties of the 0.0055- and 0.022-inch-thick sheet were somewhat different, it was necessary to select a suitable basis for comparing the failure stresses of the single-layer and multilayer tanks. The basic method selected is attributable to Irwin (ref. 5) with suitable modifications as employed in reference 2. This method uses the theory of elasticity to give a single parameter characterization of the intensity of the stress field surrounding a crack tip in a structural member or a test specimen. Unstable crack growth is supposed to occur when the stress intensity factor K reaches a level characteristic of the material known as the fracture toughness K_C .

On the basis of this fracture criteria, Irwin suggested an expression for the stress at fracture for a finite-width center-notch flat sheet:

$$\sigma = \frac{K_C}{\left[W \tan \frac{\pi}{W} \left(a + \frac{K_C^2}{2\pi\sigma_{ys}^2} \right) \right]^{1/2}} \quad (1)$$

where

- σ gross section fracture stress
- K_C fracture toughness
- W gross width of specimen
- a 1/2 of central crack length at moment of fast fracture
- σ_{ys} uniaxial yield stress

$$\frac{K_C^2}{2\pi\sigma_{ys}^2} \quad \text{uniaxial plastic-zone correction term}$$

The effect of local stress relaxation due to plastic flow near the end of the crack tip in a material having some degree of ductility is considered to be sufficiently approximated by an effective increase in the critical crack length at the moment of fast fracture. The magnitude of the increase, called the plastic-zone correction, is the term $K_C^2/2\pi\sigma_{ys}^2$ in equation (1).

In the development of the correlation equation for pressure vessels, the uniaxial plastic-zone correction term of Irwin's equation was modified experimentally for the biaxial stress state of a pressure vessel by the parameter of correlation b_G . The use of this parameter is one method of applying corrections for (1) an increase in yield strength under biaxial stress, (2) the effects of pressure vessel wall curvature, and (3) the effects of bulging around the crack tip, to at least a limited extent, from internal pressure. Thus, the correlation equation, when Irwin's method is used as a basis and where a/W is very small, can take the following form:

$$\sigma_H = \frac{K_{CN}}{\left[\pi \left(a_0 + \frac{b_G K_{CN}^2}{2\pi\sigma_{ys}^2} \right) \right]^{1/2}} \quad (2)$$

where

- σ_H hoop fracture stress
- K_{CN} nominal fracture toughness computed from eq. (1) by replacing a with a_0
- a_0 1/2 the initial length of the machined notch
- b_G parameter of correlation
- σ_{ys} uniaxial yield stress

The nominal fracture toughness K_{CN} based on the original crack length was used to correlate the data since no crack growth measuring instrumentation, particularly for cryogenic temperatures, was available at the time of testing. Also, in practice, the original crack size is a practical parameter to use in calculating acceptable stress levels for a structure with a known flaw.

RESULTS AND DISCUSSION

Table I lists the average mechanical properties of the AISI 301 stainless steel used

throughout this investigation. Table II presents the weld joint strengths of both the tanks and tensile specimens. The average hoop stresses at failure for each temperature, cold reduction, and tank type are listed in table III. Average strain values at 1000 psi pressure for the tanks are listed in table IV.

Tensile Properties

Smooth tensile strength. - In figures 6 and 7 are plotted the ultimate and yield strengths against temperature for the longitudinal and transverse directions, 60- and 70-percent cold reductions, and nominal 0.022- and 0.0055-inch thicknesses. The yield strength for all conditions increased with a decrease in temperature. The most pronounced increase took place between -320° and -423° F. The ultimate strength for the

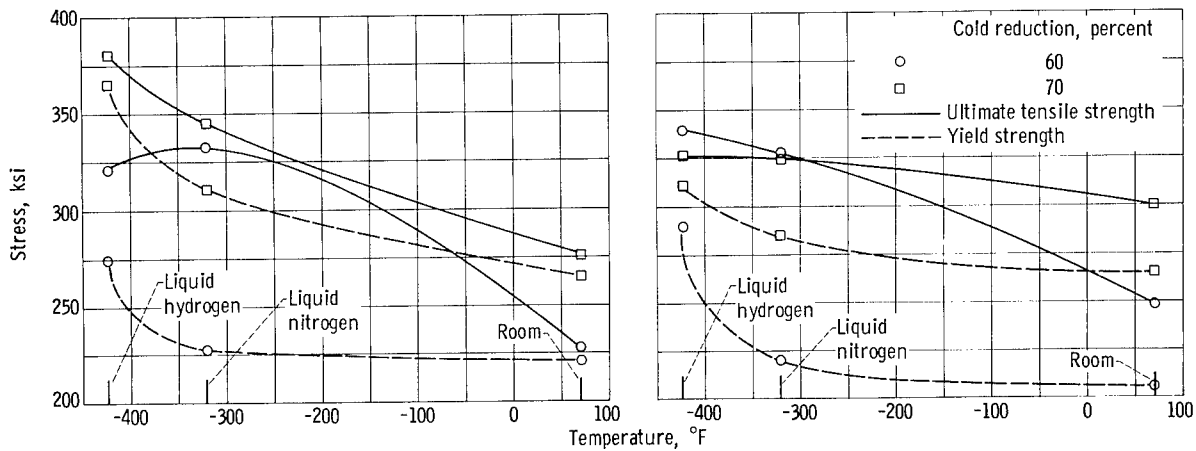

(a) Longitudinal direction. (b) Transverse direction.
Figure 6. - Strength properties of 0.0055-inch-thick AISI 301 stainless steel as function of temperature.

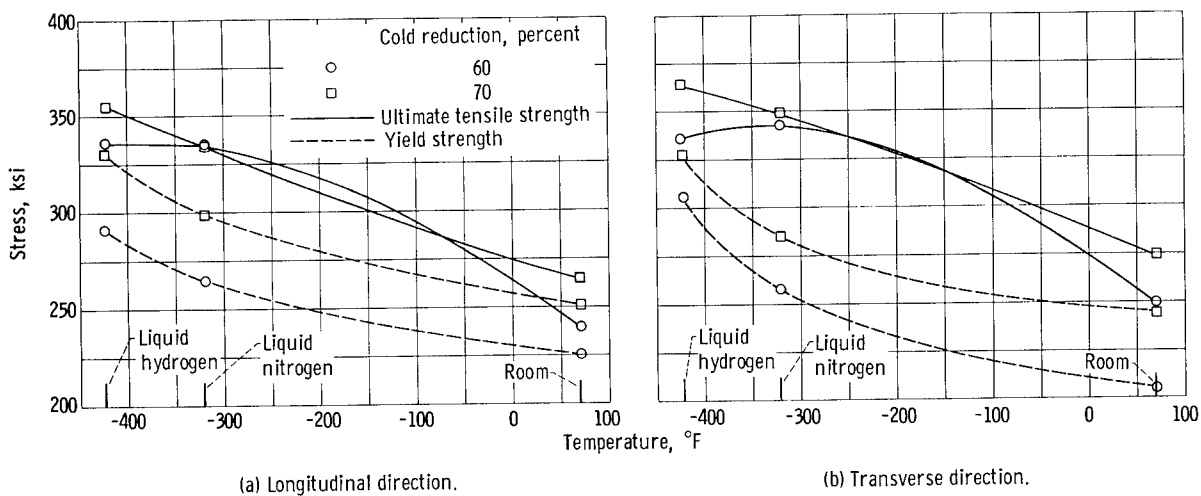

(a) Longitudinal direction. (b) Transverse direction.
Figure 7. - Strength properties of 0.022-inch-thick AISI 301 stainless steel as function of temperature.

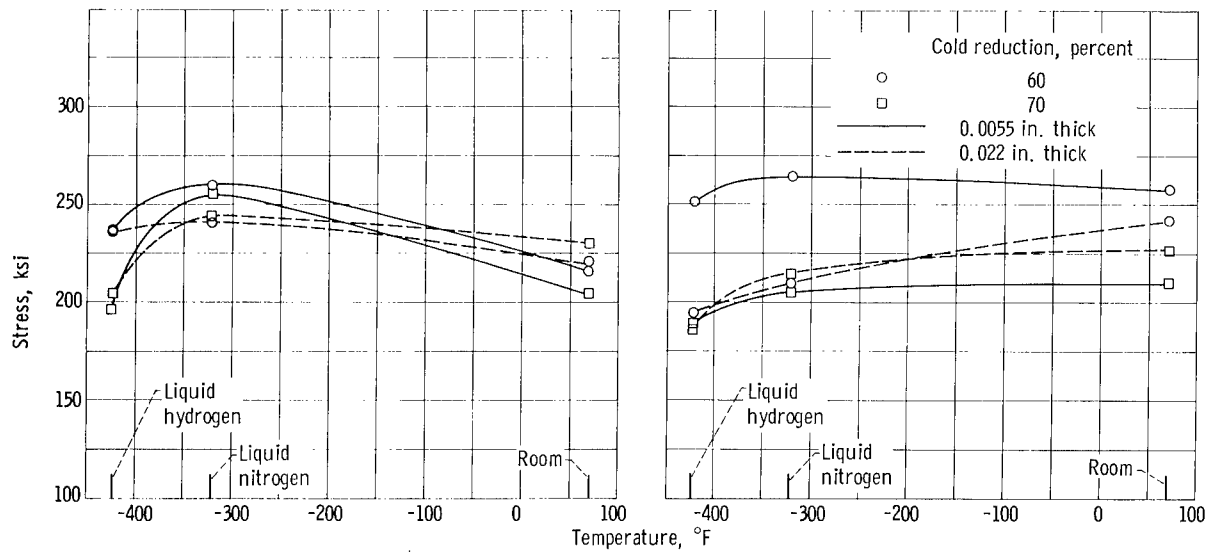

(a) Longitudinal direction. (b) Transverse direction.
 Figure 8. - Center-notch strength properties of AISI 301 stainless steel as function of temperature.

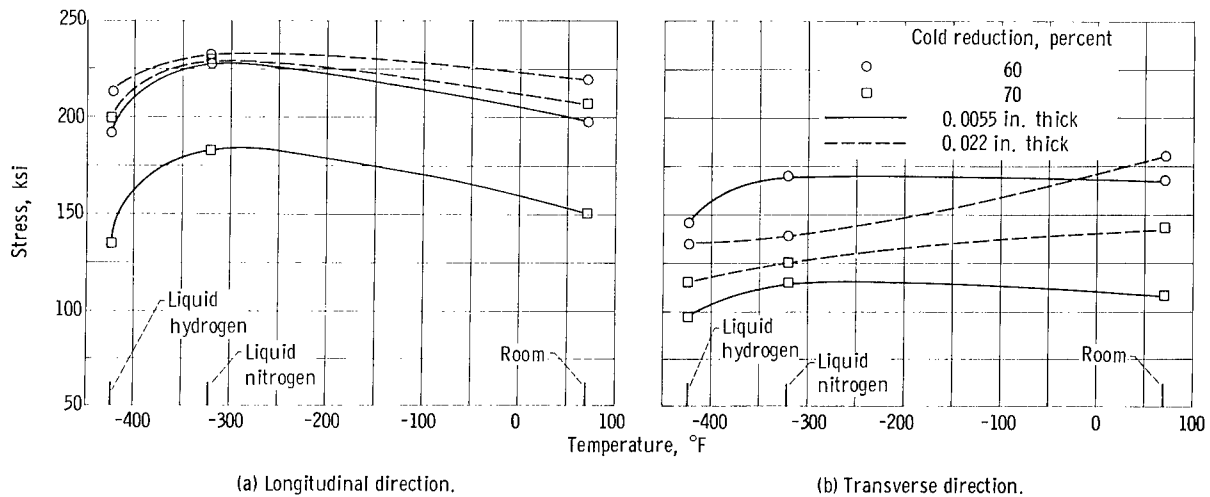

(a) Longitudinal direction. (b) Transverse direction.
 Figure 9. - Edge-notch strength properties of AISI 301 stainless steel as function of temperature.

70-percent cold-reduced material exhibited an almost linear increase as the temperature decreased. For the 60-percent cold-reduced sheet, the ultimate strength increases with decreasing temperature down to -320°F , but shows no consistent trend below this temperature.

Notch tensile strength. - The center-notch strength against temperature results are shown in figure 8. In the longitudinal direction, the notch strength increased when going from ambient to -320°F but decreased at -423°F . The 70-percent cold-reduced material exhibited the greatest reduction in strength. In general, in the transverse direction the notch strength was observed to decrease as the temperature decreased. Edge-notch data were included in figure 9 for comparison purposes only and were not used in the

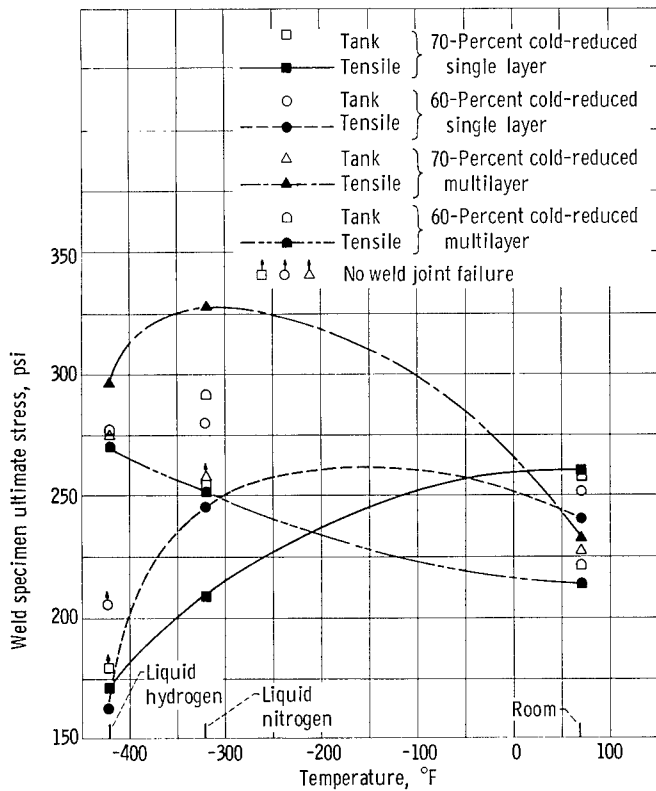

Figure 10. - Weld joint stress variation with temperature.

analysis. However, the K_{CN} values (table I) for the edge-notch 60-percent cold-reduced material were generally higher than those for the center-notch material. For the 70-percent material there appears to be no definite trend; that is, one specimen type did not always show a higher or lower value than the other.

Weld joint strength. - The data for both the tanks and welded tensile specimens are presented in figure 10 and table II. The strengths reported are based on the cross-sectional area away from the welded joint. Curves were drawn through only the tensile data because of a lack of data for tank joint strengths at all three temperatures. The tank data points with arrows attached represent failures that occurred through notches rather than at the weld

joint. Thus, for these points the weld failure stress would be at some value higher than that plotted in the figure.

In general, for a given thickness the weld joints in the 70-percent material were stronger than those in the 60-percent cold-reduced material. Thus, it would appear that the welds did not act as sharp notches, and failure was a function of the original material strength.

Scale Model Tank Strengths

Single-layer against multilayer fracture stress levels. - The comparison of the single-layer and multilayer tank fracture stress levels was complicated by the necessity for two notch lengths. The tanks were originally fabricated with the shorter notch length (0.107 in.) in both the single layer and multilayer. It was found, however, that the single-layer tanks failed at the weld joint rather than at the notch. Failure of the multilayer tanks through the short notch was made possible by the higher weld joint strength of these tanks. To overcome this weld failure problem in the single-layer tanks, it was decided to increase the notch length on these tanks to a point that would cause failure through the notch. Tensile tests were conducted to determine the required notch length, which was found to be 0.215 inch. It was not possible to change the notch length in the

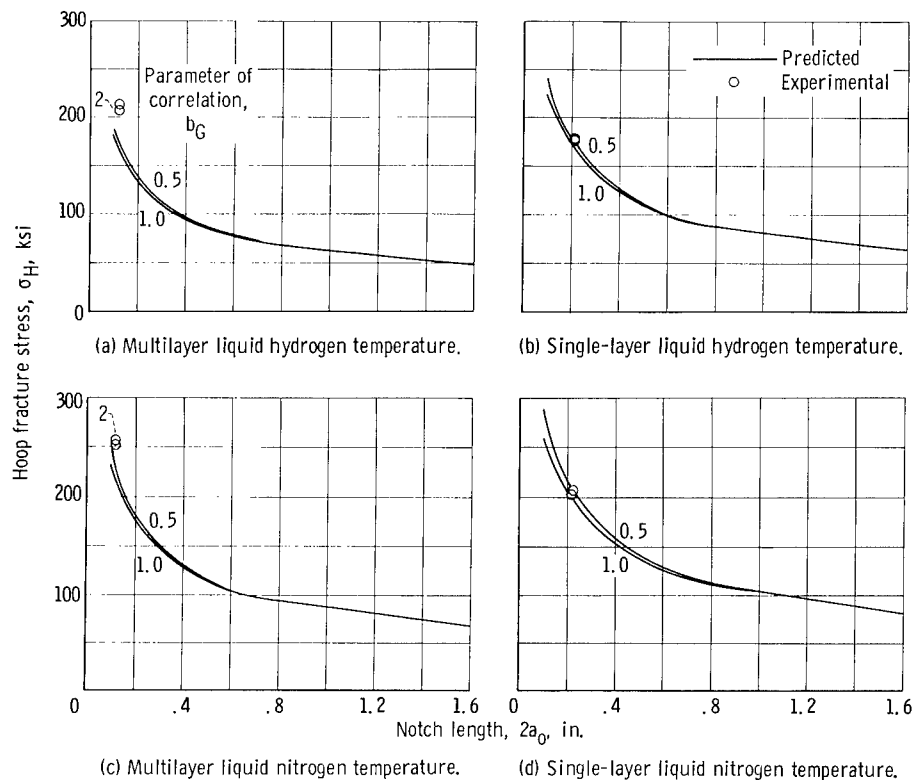

Figure 11. - Comparison of stress as function of notch length for multilayer and single-layer tanks (70-percent cold reduction).

multilayer tanks because the notches were placed in the flat sheet prior to fabrication.

Because two notch lengths were involved, a direct comparison of tank burst strengths for single-layer and multilayer tanks is not meaningful. A comparison can be made, however, by determining the relation between the actual tank failure stress for each tank configuration and the predicted failure stress based on uniaxial tensile data. This comparison was accomplished by substituting the appropriate values of a_0 , σ_{YS} , and K_{CN} from tensile data into equation (2) and hence predicting the burst hoop fracture stress σ_H for the tanks. The value of b_G used in the equation was selected by reviewing burst data obtained in reference 2 for 2014-T6 aluminum tanks. It was found in this research that values of b_G in the region of 0.5 provided a good correlation between uniaxial tensile data and tank burst strengths. In lieu of more appropriate information for AISI 301 stainless steel, values of 0.5 and 1.0 were used in the present calculations to indicate the extent of the effect of this parameter on the prediction of the tank burst strengths. A mean value for b_G of 0.75 was used in calculating all percentage deviations. When this approach is used, the curves in figures 11 and 12 of notch length against hoop-fracture stress were obtained. These curves are predictions of failure stresses for tanks with through notches that have a wall thickness of 0.022 inch (single layer) or 0.0055 inch (one layer of the multilayer). Superimposed on the curves are the results of the actual tank failures. The stresses plotted were calculated by multiplying the tank pressure times

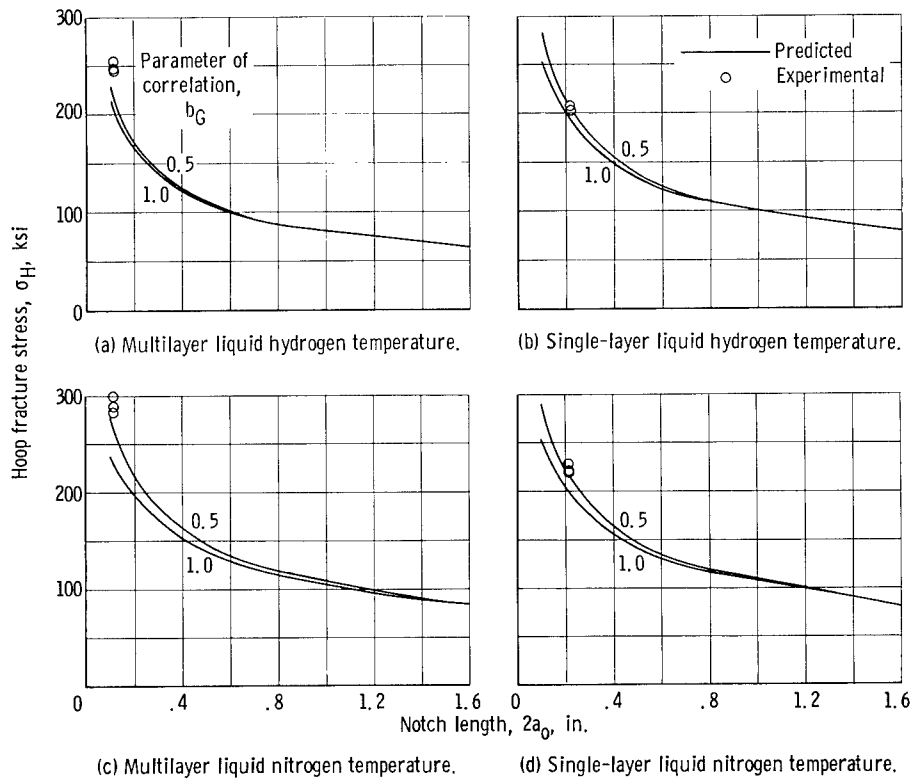

Figure 12. - Comparison of stress as function of notch length for multilayer and single-layer tanks (60-percent cold reduction).

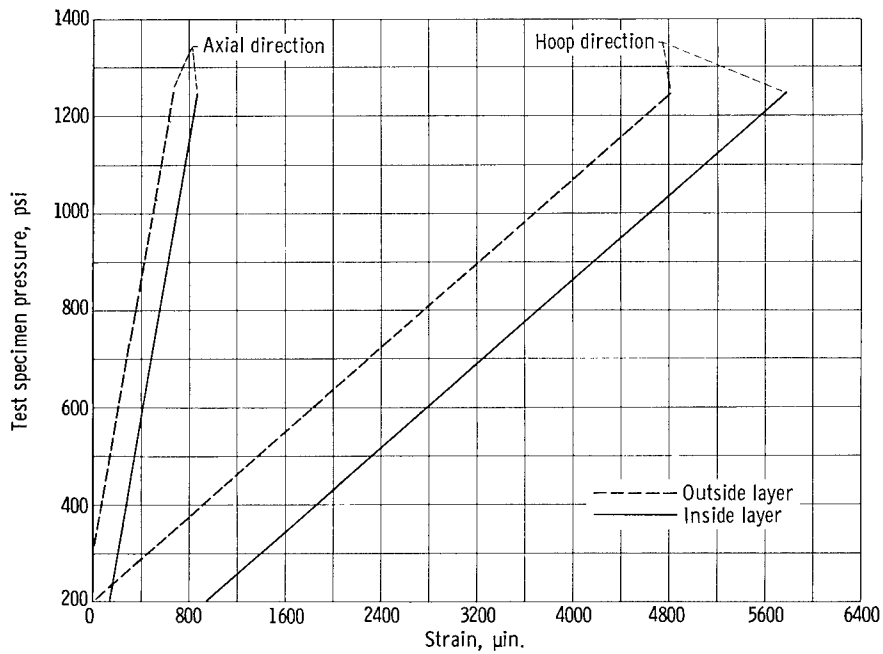

Figure 13. - Typical strain as function of pressure plot for multilayer tanks.

the radius and by dividing by the total wall thickness. Three specimens were run for each temperature and tank type. The data points for the single-layer tanks fall between or very close to the calculated curves. Based on the assumption that the curves do represent failure for single-layer through notches, the multilayer tanks were superior in all cases since the experimental results fell above the predicted curves. At -423° F the 70-percent cold-reduced material exhibited a 20-percent increase in burst stress over the predicted value from the curve (fig. 11(a)). For the same conditions, the single-layer tanks (fig. 11(b)) show a maximum deviation of approximately 5 percent from the average predicted value when $b_G = 0.75$. At -320° F an increase of 15 percent was observed for the multilayer tanks (fig. 11(c)). Here the predicted value for the single-layer tanks was the same as the experimental (fig. 11(d)). The 60-percent cold-reduced multilayer tanks at both -423° and -320° F show approximately a 17-percent increase in burst stress (figs. 12(a) and (c)). The burst stresses for the single-layer tanks were from 2 to 6 percent higher than the predicted values (figs. 12(b) and (d)). In figure 12(c), for the 60-percent cold-reduced material the predicted curves for multilayer tanks at -320° F were computed from the tensile data as before; however, the curves are probably not reliable because the material exhibits notch ductile characteristics (net fracture stress greater than yield stress).

In addition to the restraint on crack propagation in the multilayer tanks previously discussed, the increased strength exhibited by these tanks may also have resulted from their inherent resistance to the detrimental effect of the bulge that forms around the crack area. The increase in the localized stress at the crack tip due to this bulge effect would reduce the ultimate strength or burst pressure of a single-layer tank.

Also, it is important to note that the failure stresses for both single-layer and multilayer tanks were lower for the 70-percent cold-reduced material than for the 60-percent material, even though the higher cold-reduced sheet exhibited greater yield and ultimate strength. Thus, for many applications at cryogenic temperatures, cold reductions in excess of 60 percent would probably not be satisfactory even if the multilayer approach is used.

Inner and outer strain levels. - On the multilayer tanks strain gages were placed on the inside surface of the inner layer and on the outside surface of the outer layer in order to give an indication of the stress distribution in the layers. Figure 13 shows typical strain against pressure curves. Note that the outside layer exhibited approximately 1000 microinches less hoop strain than the inside layer. This was probably due to lack of sufficient tension on the sheet material during tank fabrication. Too much tension, however, would result in buckling of the inside layer. An optimum sheet tension during fabrication would probably result in a more uniform strain being carried by each layer.

The lower stress level on the outer layer, where the notch was located, probably accounts for some of the increased strength of the multilayer tanks shown in figures 11

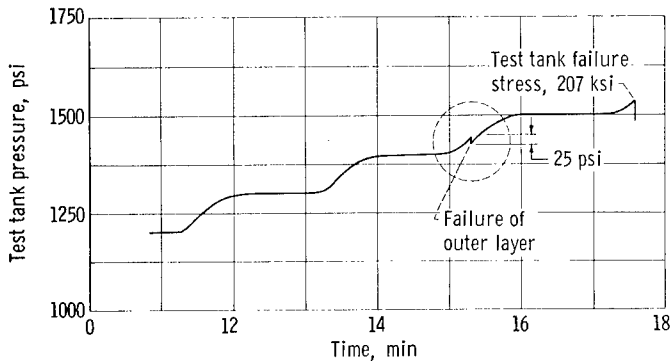

Figure 14. - Pressure as function of time plot for multilayer tank at -423° F.



Figure 15. - Typical failure for single-layer and multilayer tanks.

and 12. Calculations have indicated, however, that this effect accounts for only part of the fracture strength increase shown.

Outer-layer failures. - During bursting of the multilayer tanks, failure of the outer layer (which contained the sharp notch) was observed prior to final burst in three out of twelve tests. This failure did not disrupt the structural integrity of the tank. Figure 14 is a reproduction of the pressure against time plot for such a test at -423° F. At the instant failure of the outer layer occurred, a pressure drop of 25 psig took place inside the tank. This was due to the increase in strain on the remaining layers with a resultant volume increase. Final failure of the tank occurred with an increase in pressure of 50 to 75 psig (3 to 5 percent of burst pressure). It is important to note here that failure of the outer layer did not necessarily mean catastrophic failure of the tank. Such a structure when subjected to surface damage could mean the difference between fail safe and catastrophic failure. Figure 15 illustrates the difference between the two types of tank failure.

Two-cycle failures. - Problems were encountered during testing of

some of the tanks which required shutdown of the test. The test specimen would be warmed up to ambient temperature, dried out, and scheduled to run again at a future date. Three such tanks, on the second cycle, had failure occur at hoop stresses lower than the hoop stress previously obtained on the first cycle. Other two-cycle tanks that were subjected to much lower stresses on the first cycle did not show this same trend. The stress levels, temperature, and tank description are summarized in table V. In the one instance the failure stress was 11 percent less than the original hoop stress obtained

on the first cycle. One probable explanation of this is that the austenitic stainless underwent a phase change to the more notch sensitive martensite. This effect has been observed (ref. 6) under conditions of low temperature and high stress followed by a warming period at ambient temperature. Another possible reason is that crack growth during the first cycle would result in a lower stress level for crack growth initiation on the second cycle.

SUMMARY OF RESULTS

Based on the analysis of the data, it appears that the multilayer scale model tanks used in this investigation were superior to the single-layer tanks from the standpoint of structural strength in the presence of sharp notches. The burst stresses of the multilayer tanks were 15 to 20 percent higher than the predicted value of burst stress for similar single-layer tanks. The maximum difference between measured and predicted burst stress for all single-layer tanks was 6 percent. The increased strength exhibited by the multilayer tanks may have partially resulted from the load shifting to the inner layers before the critical crack length was experienced in the outer layer. Also, the inherent resistance of these tanks to the detrimental effect of the bulge, which forms around the crack area, may have contributed to this added strength.

During bursting of the multilayer tanks, failure of the outer layer (which contained the sharp notch) was observed prior to complete tank failure. Such a structure when subjected to surface damage could mean the difference between fail safe and catastrophic failure.

The premature failures of three tanks following a previous high pressure cycle may be attributed to the changing of the austenitic stainless to the more notch sensitive martensitic phase. This effect has been observed under conditions of low temperature and high stress followed by a period of time at ambient temperature.

Failure stresses for both single-layer and multilayer tanks were lower for the 70-percent cold-reduced material than for the 60-percent material, even though the higher cold-reduced sheet exhibited greater yield and ultimate stress. Thus, for many applications at cryogenic temperatures, cold reductions of above 60 percent would probably not be satisfactory even if the multilayer approach to construction is utilized.

Lewis Research Center,
National Aeronautics and Space Administration,
Cleveland, Ohio, May 4, 1965.

REFERENCES

1. Voth, R. J. : The Correlation of Laboratory Specimens and Strip Wound Pressure Vessel Tests. Mechanical and Metallurgical Behavior of Sheet Materials, Proc. Seventh Sagamore Ordnance Materials Res. Conf., Aug. 16-19, 1960.
2. Getz, D. L. ; Pierce, W. S. ; and Calvert, H. F. : Correlation of Uniaxial Notch Tensile Data with Pressure-Vessel Fracture Characteristics. Paper No. 63-WA-187, ASME, 1963.
3. Calvert, H. F. ; and Kemp, R. H. : Determination of Pressure Vessel Strengths at -423° F as Influenced by Notches of Various Radii. Paper No. 520B, SAE, 1962.
- 4. Orange, Thomas W. : Tensile Coupon Tests of Cryoformed AISI 301 Stainless-Steel Pressure Vessels at Cryogenic Temperatures. NASA TN D-2202, 1964. *NAS. 259*
5. Irwin, G. R. : Fracture Testing of High-Strength Sheet Materials Under Conditions Appropriate for Stress Analysis. Rept. No. 5486, Naval Res. Lab., July 27, 1960.
6. Watson, J. F. ; and Christian, J. L. : A Study of Austenite Decomposition at Cryogenic Temperatures. Rept. No. ERR-AN-057, General Dynamics/Astronautics, June 9, 1961.

TABLE I. - AVERAGE TENSILE PROPERTIES OF COLD REDUCED AISI 301 STAINLESS STEEL

Cold reduction, percent	Thickness, in.	Direction	Test temperature, °F	Ultimate tensile strength, ksi	Yield strength (0.2 percent offset), ksi	Elastic modulus, psi	Net center-notch tensile strength, ksi	Center notch to yield strength ratio	Center-notch nominal fracture toughness, K_{CN} , ksi√in.	Net edge-notch tensile strength, ksi	Edge notch to yield strength ratio	Edge-notch nominal fracture toughness, K_{CN} , ksi√in.
60	0.0220	Longitudinal	70	239	225	25.6×10 ⁶	221	0.982	129.8	219	0.974	146.5
			-320	335	264	27.0	241	.913	136.9	232	.879	147.1
			-423	336	291	27.3	236	.811	126.2	213	.732	129.6
	0.0054	Transverse	70	249	210	30.2×10 ⁶	192	0.914	107.1	180	0.867	113.4
			-320	342	257	30.5	159	.619	79.5	139	.541	78.8
			-423	336	306	31.4	144	.471	69.4	135	.441	75.0
70	0.0226	Longitudinal	70	227	221	27.1×10 ⁶	216	0.977	100.6	197	0.891	126.4
			-320	332	227	30.7	259	1.141	139.2	227	1.000	155.0
			-423	321	274	27.4	235	.858	101.1	192	.701	113.6
	0.0056	Transverse	70	248	211	31.1×10 ⁶	207	0.981	97.7	167	0.792	102.2
			-320	327	219	32.6	214	.977	99.4	170	.776	103.5
			-423	340	289	32.7	200	.692	80.0	147	.505	82.4
70	0.0226	Longitudinal	70	264	251	25.5×10 ⁶	230	0.916	131.0	207	0.824	128.6
			-320	334	298	26.3	243	.815	129.9	229	.768	138.7
			-423	355	330	27.6	204	.618	101.8	200	.606	116.6
	0.0056	Transverse	70	274	244	30.2×10 ⁶	177	0.725	92.2	143	0.586	82.3
			-320	348	285	32.2	164	.575	80.9	125	.439	69.7
			-423	363	327	33.0	136	.416	65.5	116	.355	63.7
70	0.0056	Longitudinal	70	276	265	27.5×10 ⁶	204	0.770	84.8	150	0.556	86.3
			-320	345	311	31.5	255	.820	107.9	182	.585	104.4
			-423	381	366	30.5	197	.538	76.7	135	.507	74.1
	0.0056	Transverse	70	299	266	32.1×10 ⁶	160	0.602	63.1	108	0.406	59.4
			-320	324	285	33.3	155	.544	60.2	115	.403	63.1
			-423	326	311	35.4	138	.444	52.9	97	.312	53.3

TABLE III. - AVERAGE HOOP STRESS OF AISI 301 STAINLESS

STEEL TANKS AT FAILURE

Cold reduction, percent	Type of tank	Thickness, in.	Test temperature, °F	Gross ^a hoop stress, ksi	Average gross hoop stress, ksi
60	Single layer	0.022	-320	228	222
				220	
				218	
	Multilayer	0.022	-320	284	291
				290	
				300	
70	Single layer	0.023	-320	247	249
				244	
				255	
	Multilayer	0.022	-320	204	204
				203	
				206	
Single layer	0.023	-423	180	179	
			180		
			178		
Multilayer	0.022	-320	253	256	
			258		
			258		
Single layer	0.023	-423	213	210	
			209		
			207		

^aAll failures occurred through the notch.

TABLE II. - AVERAGE WELD JOINT STRENGTH

Cold reduction, percent	Number of layers at weld joint	Thickness of each layer, in.	Test temperature, °F	Ultimate tensile strength of welded tensile ^a specimens, ksi	Tank ^a hoop stress, ksi
60	2	0.0220	70	241	252
			-320	246	280
			-423	162	b>205
	5	0.0054	70	214	222
			-320	252	292
			-423	270	278
70	2	0.0226	70	260	259
			-320	209	254
			-423	172	b>179
	5	0.0056	70	233	228
			-320	328	b>258
			-423	296	275

^aStress based on area away from weld joint.

^bFailure occurred through notch rather than weld joint.

6197
H. Wagner

ERRATA

NASA TECHNICAL NOTE D-2949

STRENGTH COMPARISON OF FLAWED SINGLE-LAYER AND
MULTILAYER AISI 301 STAINLESS-STEEL PRESSURE
VESSELS AT CRYOGENIC TEMPERATURES

by William S. Pierce

October 1965

The following tables should be added to the report:

TABLE IV. - AVERAGE STRAIN VALUES OF TANK TEST SPECIMENS AT 1000 PSI LOAD

Cold reduction, percent	Type of tank	Test temperature, °F	Average hoop strain inside layer, μ in.	Average hoop strain outside layer, μ in.	Average longitudinal strain inside layer, μ in.	Average longitudinal strain outside layer, μ in.
60	Single layer	-320	----	4200	----	760
	Multilayer	-320	4800	4100	----	700
	Single layer	-423	----	4100	----	700
	Multilayer	-423	4700	3700	500	700
70	Single layer	-320	----	4400	----	800
	Multilayer	-320	4300	3500	----	760
	Single layer	-423	----	4200	----	760
	Multilayer	-423	4400	3400	----	770

TABLE V. - TEST TANK FAILURE STRESSES AFTER
PREVIOUS HIGH PRESSURE CYCLE

Cold reduction, percent	Type of tank	Test temperature, °F	Hoop stress (first cycle), ksi	Hoop stress (second cycle) failure, ksi
60	Single layer	-423	203	190
70	Single layer	-423	180	169
60	Multilayer	-423	248	221

"The aeronautical and space activities of the United States shall be conducted so as to contribute . . . to the expansion of human knowledge of phenomena in the atmosphere and space. The Administration shall provide for the widest practicable and appropriate dissemination of information concerning its activities and the results thereof."

—NATIONAL AERONAUTICS AND SPACE ACT OF 1958

NASA SCIENTIFIC AND TECHNICAL PUBLICATIONS

TECHNICAL REPORTS: Scientific and technical information considered important, complete, and a lasting contribution to existing knowledge.

TECHNICAL NOTES: Information less broad in scope but nevertheless of importance as a contribution to existing knowledge.

TECHNICAL MEMORANDUMS: Information receiving limited distribution because of preliminary data, security classification, or other reasons.

CONTRACTOR REPORTS: Technical information generated in connection with a NASA contract or grant and released under NASA auspices.

TECHNICAL TRANSLATIONS: Information published in a foreign language considered to merit NASA distribution in English.

TECHNICAL REPRINTS: Information derived from NASA activities and initially published in the form of journal articles.

SPECIAL PUBLICATIONS: Information derived from or of value to NASA activities but not necessarily reporting the results of individual NASA-programmed scientific efforts. Publications include conference proceedings, monographs, data compilations, handbooks, sourcebooks, and special bibliographies.

Details on the availability of these publications may be obtained from:

SCIENTIFIC AND TECHNICAL INFORMATION DIVISION
NATIONAL AERONAUTICS AND SPACE ADMINISTRATION
Washington, D.C. 20546