

ARMY RESEARCH LABORATORY



# Fabrication and Evaluation of Welded Ti-6Al-4V Test Sections

by Scott Grendahl, Daniel Snoha,  
and Brijmohan Roopchand

ARL-TR-2533

June 2001

Approved for public release; distribution is unlimited.

20010806 128

The findings in this report are not to be construed as an official Department of the Army position unless so designated by other authorized documents.

Citation of manufacturer's or trade names does not constitute an official endorsement or approval of the use thereof.

Destroy this report when it is no longer needed. Do not return it to the originator.

# Army Research Laboratory

Aberdeen Proving Ground, MD 21005-5069

---

ARL-TR-2533

June 2001

---

## Fabrication and Evaluation of Welded Ti-6Al-4V Test Sections

Scott Grendahl and Daniel Snoha  
Weapons and Materials Research Directorate, ARL

Brijmohan Roopchand  
U.S. Army Armament Research, Development, and Engineering Center

---

Approved for public release; distribution is unlimited.

---

---

## Abstract

---

There has been wide support for the continued reduction in weight of heavy armor combat systems. Of course no one is willing to give up performance with this reduction in weight. This program investigated the feasibility of utilizing Ti-6Al-4V as an alternate armor material for the M1 Abrams turret glacis as opposed to the presently utilized RHA steel. Two turret glacis test sections were fabricated from Ti-6Al-4V armor plate, and one was fabricated from RHA steel. These sections were ballistic tested vs. common threats. The weld joint design is described from a theoretical basis as well as functional performance. The ballistic results of all test sections are discussed in detail, and recommendations for future work are provided.

---

## Contents

---

<b>List of Figures</b>	<b>v</b>
<b>List of Tables</b>	<b>vii</b>
<b>1. Introduction</b>	<b>1</b>
<b>2. Fabrication of the ARL Test Section</b>	<b>1</b>
<b>3. Joint Designs</b>	<b>2</b>
<b>4. ARL Test Section Ballistic Results</b>	<b>2</b>
4.1 Discussion of ARL Ballistic Testing .....	8
4.2 Fabrication of the GDLS Test Section .....	9
<b>5. GDLS Test Section Ballistic Results</b>	<b>9</b>
5.1 Discussion of GDLS Ballistic Testing.....	11
5.2 Assessment of ARL Weld Joints .....	12
<b>6. Tensile Testing</b>	<b>27</b>
<b>7. Chemistry</b>	<b>28</b>
<b>8. Conclusions</b>	<b>28</b>
<b>Distribution List</b>	<b>29</b>
<b>Report Documentation Page</b>	<b>31</b>

INTENTIONALLY LEFT BLANK.

---

## List of Figures

---

Figure 1. Schematic of the front plate to top plate weld joint.....	2
Figure 2. Schematic of the front plate to side plate weld joint.....	3
Figure 3. Schematic of the front plate to base plate weld joint.....	3
Figure 4. Schematic of back plate to top plate weld joint.....	4
Figure 5. Schematic of back plate to side plate weld joint.....	4
Figure 6. Schematic of the top plate to side plate weld joint.....	5
Figure 7. ARL overview, schematic 1.....	6
Figure 8. ARL overview, schematic 2.....	6
Figure 9. ARL overview, schematic 3.....	7
Figure 10. Photograph of the tertiary cracking along the base plate of the ARL test section.....	7
Figure 11. Schematic of the redesigned front to base plate weld joint.....	8
Figure 12. GDLS overview, schematic 1.....	9
Figure 13. Design of GDLS back to top plate weld vs. test section.....	9
Figure 14. Photograph of the GDLS test section back to top and back to side weld designs.....	10
Figure 15. GDLS overview, schematic 2.....	11
Figure 16. Photograph of the GDLS test section failure of the base plate.....	11
Figure 17. Macro cross section of the front plate to top plate weldment.....	12
Figure 18. Cross section of the front plate to top plate weld bead.....	13
Figure 19. Cross section showing a fine crack in the front plate to top plate weldment.....	13
Figure 20. Front to top plate fusion zone with grain growth across weld pass boundaries.....	14
Figure 21. Front plate to top plate weldment showing approximately 1/8-in HAZ.....	14
Figure 22. Macro cross section of the front to side plate weldment.....	15
Figure 23. Cross section depicting the front to side plate fusion zone.....	15
Figure 24. Front to side plate weld root.....	16
Figure 25. Front to side plate middle of the fusion zone.....	16

Figure 26. Front to side plate weld cap.....	17
Figure 27. Macro cross section of the front to base plate.....	17
Figure 28. Cross section of the front to base plate fusion zone.....	18
Figure 29. Cross section of the front to base plate weld root.....	18
Figure 30. Cross section of the middle of the fusion zone of the front to base plate weld.....	19
Figure 31. Cross section of the front to base plate weld cap.....	19
Figure 32. Macro cross section of the back to top plate.....	20
Figure 33. Cross section of the back to top plate weld fusion zone.....	20
Figure 34. Cross section of the root of the back to top plate weldment.....	21
Figure 35. Cross section of the middle of the fusion zone of the back to top plate weldment.....	21
Figure 36. Cross section of the cap of the back to top plate weldment.....	22
Figure 37. Macro cross section of the base to side plate weldment.....	22
Figure 38. Cross section of the back to side plate weld fusion zone.....	23
Figure 39. Cross section of the root of the back to side plate weldment.....	23
Figure 40. Cross section of the middle of the back to side plate weld fusion zone.....	24
Figure 41. Cross section of the back to side plate weld cap.....	24
Figure 42. Macro cross section of the top to side plate weldment.....	25
Figure 43. Cross section of the top to side plate weld fusion zone.....	25
Figure 44. Cross section of the root of the top to side plate weldment.....	26
Figure 45. Cross section of the middle of the top to side plate weld fusion zone.....	26
Figure 46. Cross section of the cap of the top to side plate weldment.....	27

---

## List of Tables

---

Table 1. Tensile results from the ARL Ti-6-4 test section. ....	27
Table 2. ARL and GD test section chemistry results for heat R3392 and R2494.....	28

INTENTIONALLY LEFT BLANK.

---

## 1. Introduction

---

The U.S. Army Tank-automotive and Armament Command (TACOM), Tank Automotive Research Development and Engineering Center (TARDEC) initiated a program through the titanium MANTECH program to evaluate the feasibility of creating a functional titanium test section representing part of an M1 Abrams turret. The test section simulating the M1 turret glacis was developed jointly by the M1 PM office, General Dynamics Land Systems (GDLS), and the U.S. Army Research Laboratory (ARL) Weapons and Materials Research Directorate (WMRD). The test section was designed to contain a classified armor package. Both GDLS and ARL-WMRD separately designed and created Ti-6Al-4V test sections for evaluation. Additionally, GDLS created an RHA test section. Since the GDLS design would be proprietary, TACOM wanted ARL-WMRD to support the program by creating a separate test section. Both titanium designs, as well as an RHA test section, included the identical armor package and were tested against a KE, CE, and shock projectile. The approximate size of the test sections was 63 × 38 × 28 in.

---

## 2. Fabrication of the ARL Test Section

---

The titanium plate utilized by ARL-WMRD was Ti-6Al-4V (ASTM Grade 5) manufactured by Timet (Titanium Metals Corporation) and procured through TACOM. The plates were manufactured from 34-in vacuum arc remelt (VAR) ingots from heat no. R3392. Based on prior experience with joining titanium, ARL chose to plasma cut the sides and the top of the test section and use conventional machining for the front and back. The backing strips for the welds were water jet cut. After several design iterations, it was decided that joints would be modified from full machining with interlocking steps. The modification included the incorporation of tacked on backing strips to maximize the cross-sectional area of the weld and to minimize the machining necessary to maintain the test schedule of the program. Schematics of the individual joint designs are included in the next section of this report. All joints were ground with silicon carbide grinding wheels and solvent (normalized propyl bromide) cleaned prior to welding. The latter was more than likely superfluous. Plates exceeding 1 in were preheated to 125 °F prior to welding. Backing strips were tack welded onto the plates prior to final assembly to prevent the root pass from experiencing arc blow through, contain shield gases, and aid in assembly of the structure. The welds were fabricated with 0.045-in extra low interstitial (ELI) titanium wire. ELI wire was utilized to provide extra ductility within the welds.

A 3-in trailing shield and backing shield were utilized when appropriate, in conjunction with 100% argon shielding gas. Interpass temperature was kept within 250 °F between all passes. Each pass was made at 20–25 in/min forehand travel, and was cleaned with a stainless wire brush before applying the next weld. All weld starts and stops were ground with tree-shaped tungsten carbide burrs on a rotary tool. The weld process utilized was pulse metal inert gas (MIG) at 300 A, and the wire feed was approximately 800 ft/min.

---

### 3. Joint Designs

---

The ARL-WMRD joint designs incorporated 60° openings (when feasible) and backing strips to prevent arc blow through. Lands of 1/8 in were specified at the roots of the welds. Figures 1–6 present the schematics of the joint designs of the ARL-WMRD test section. The schematics are not drawn to scale. The weld joints between the sides and the base were fillet welds.

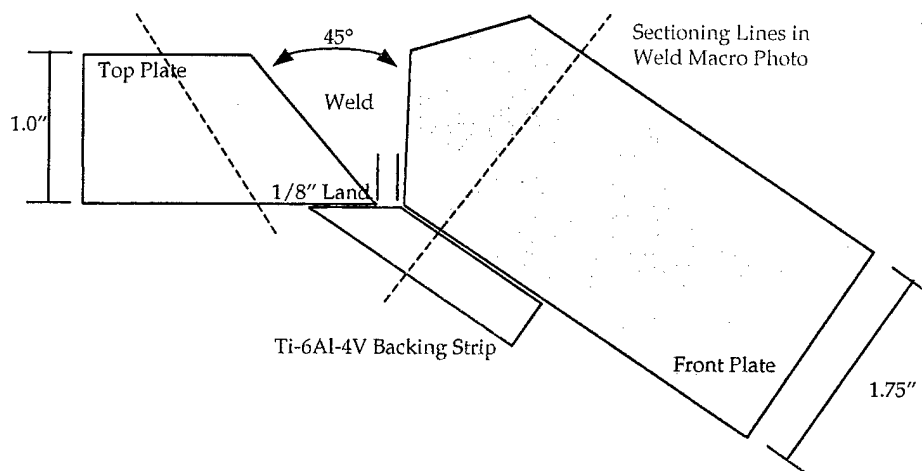

Figure 1. Schematic of the front plate to top plate weld joint.

---

### 4. ARL Test Section Ballistic Results

---

The first ballistic shot was a KE round that completely penetrated the target. The second round, a CE round, left only a 1/2-in penetration hole in the back plate,

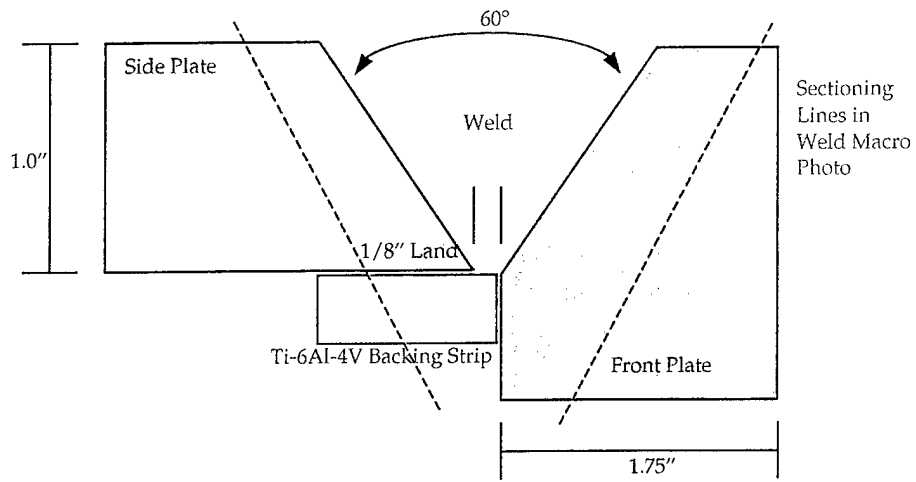

Figure 2. Schematic of the front plate to side plate weld joint.

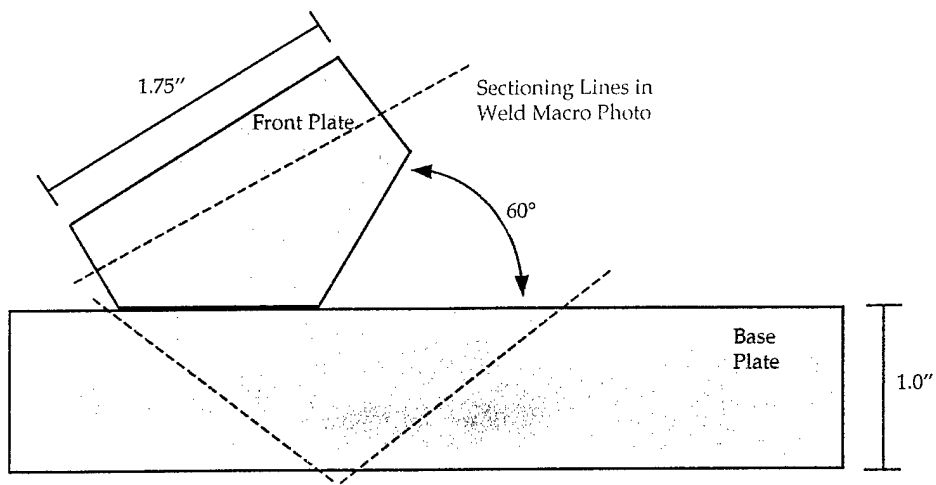

Figure 3. Schematic of the front plate to base plate weld joint.

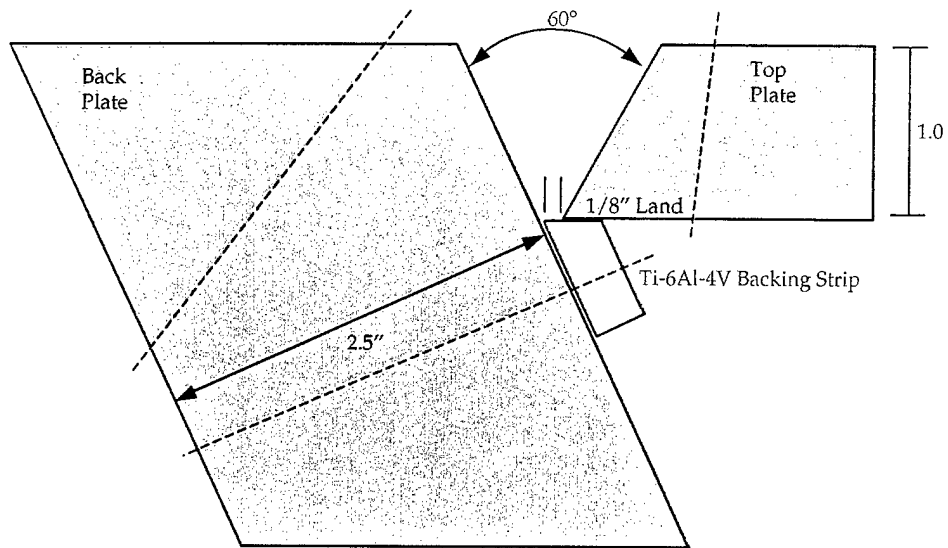

Figure 4. Schematic of back plate to top plate weld joint.

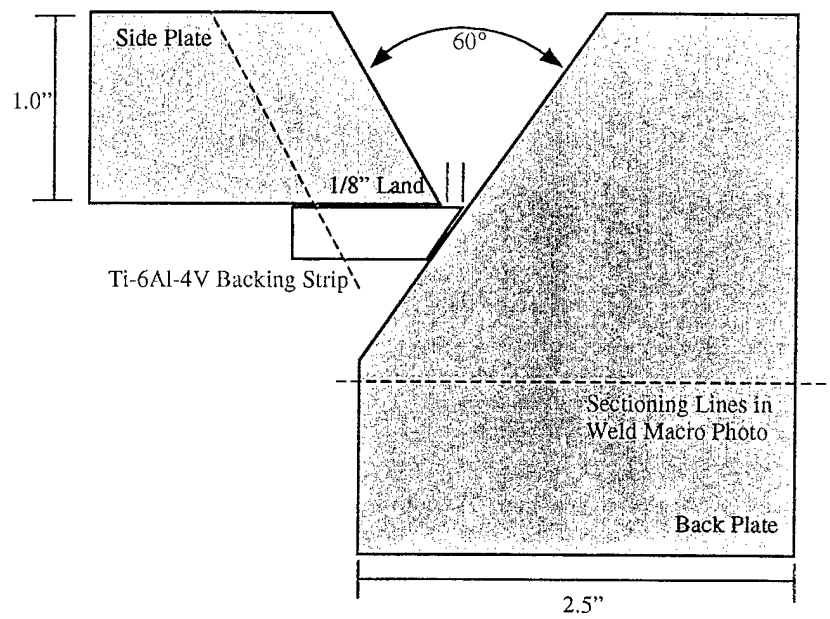

Figure 5. Schematic of back plate to side plate weld joint.

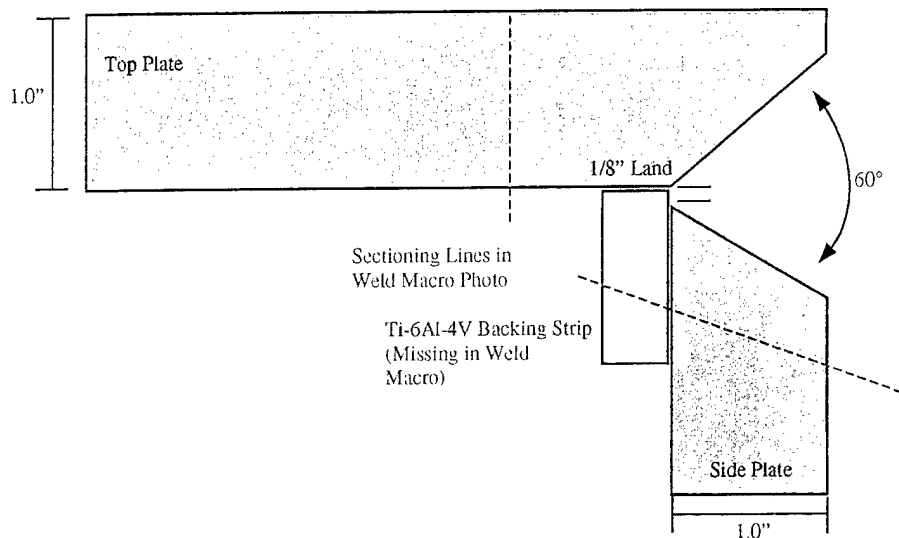

Figure 6. Schematic of the top plate to side plate weld joint.

but was still considered a penetration. The third and final round was a shock round to test the weld toughness, the result of which was considerable cracking. The ARL section had its primary fracture from this round at the top back left hand side (LHS) of the box, point A in Figure 7. Inspection revealed that the inside surface of the top plate in that area had taken an impact load from the armor package during the ballistic event (See GDLS Test Section Ballistic Results). Consequently, the top plate to back plate joint failed from overpressure down a 23-in span, point A, along the weld. The top 1/4-1/2 in of this weld zone failed in shear. Beyond this region, cracking advanced out of the weld joint and proceeded into the base material of the top plate, most likely as a result of the lifting hook being welded across the plate interface in this area (see schematic). Cracking progressed through the top plate, until the right hand side (RHS) of the top to side plate joint was reached at the approximate halfway point (Figure 7, point B). The crack then turned and followed the top to side plate joint approximately 6 in before arresting. The other end of the crack, emanating from the primary fracture, met (at the top back LHS corner, point C) with a crack from a secondary fracture that initiated at the base of the LHS gusset support (Figures 7 and 8, point D). In all likelihood, cracking originated from this area due to the fact that several weld beads converge here. This area was almost directly behind the point of collision of the round as it impacted the back plate (or impacted the armor package that, in turn, impacted the back plate). Failure most likely occurred here because the weld beads were discontinuous in this area.

The secondary fracture, crack no. 1 in Figure 8, ran along the back to bottom plate interface and continued approximately 30 in until it arrested. Crack no. 2 proceeded to the LHS (from front orientation) bottom back corner and wrapped

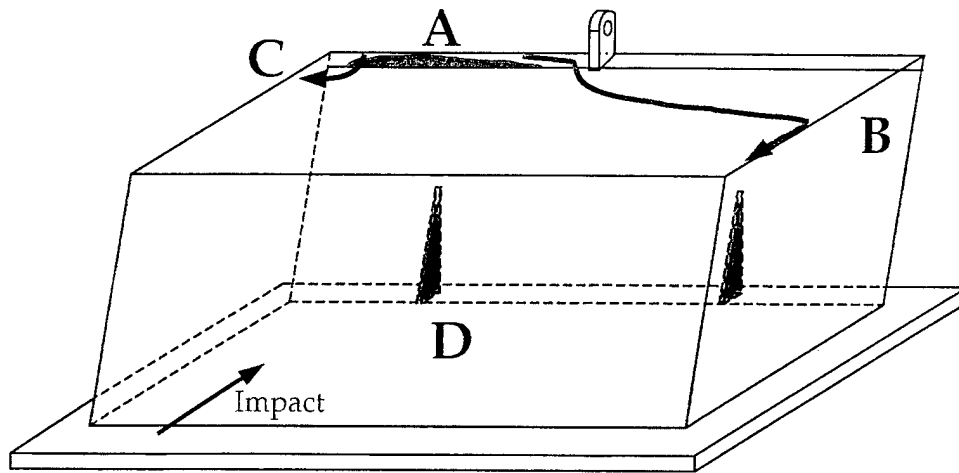

Figure 7. ARL overview, schematic 1.

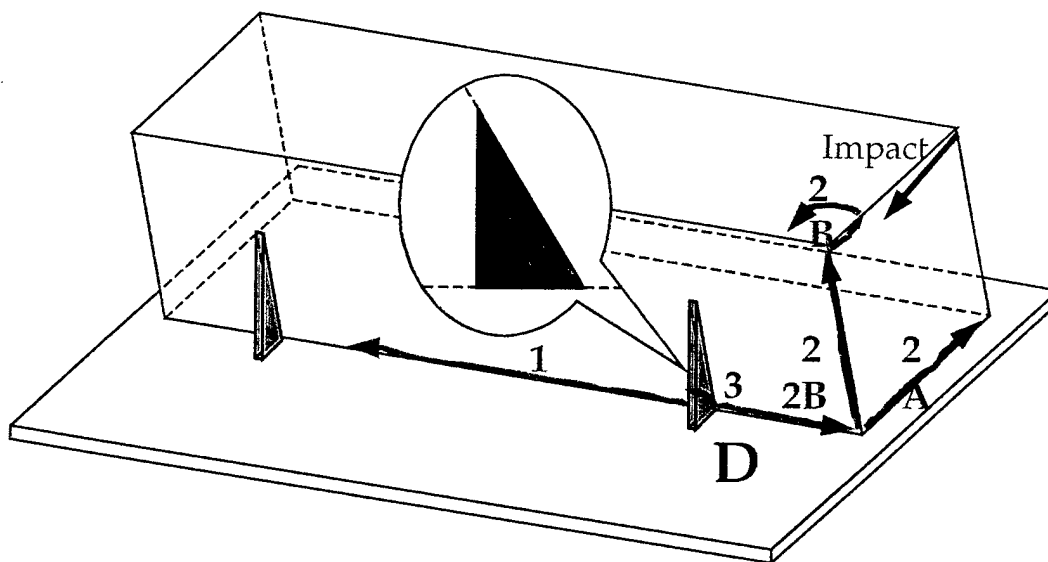

Figure 8. ARL overview, schematic 2.

around the edge of the box. It then split in two, cracks 2A and 2B. Crack 2A proceeded along the LHS to the bottom weld interface approximately 15 in where it arrested. Crack 2B ran along the LHS back to the side weld interface and curled around the top of the plate where it met with the crack from the primary fracture and arrested. Crack no. 3 proceeded directly into the base material of the LHS gusset and ran entirely through the support; Figure 8 shows the details.

Tertiary fracture occurred entirely within the base plate material from the entry of the shock round in the front plate. The 1-in-thick base plate failed along a 14-in section due to the bending moment and stresses from the impacting projectile. This can be observed in Figure 9, point E, and in Figure 10. This crack can most likely be eliminated from a simple redesign of the front to base plate weld and would not occur on a vehicle due to the joint design differences.

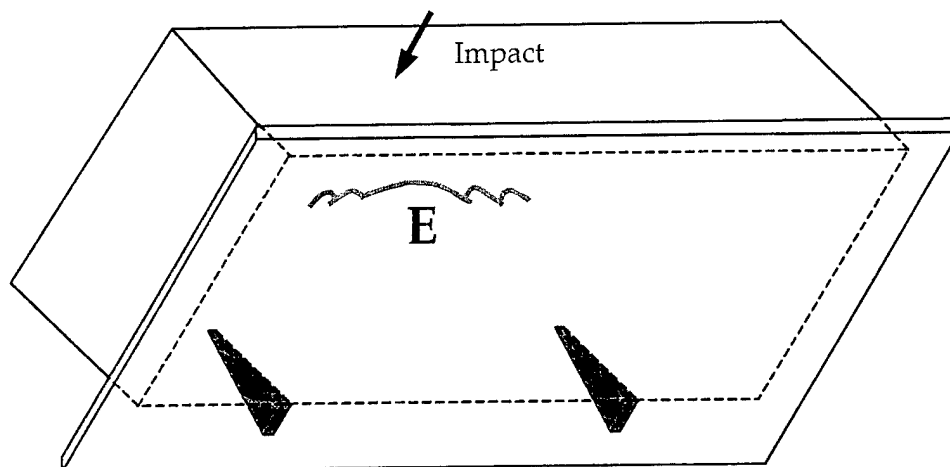

Figure 9. ARL overview, schematic 3.

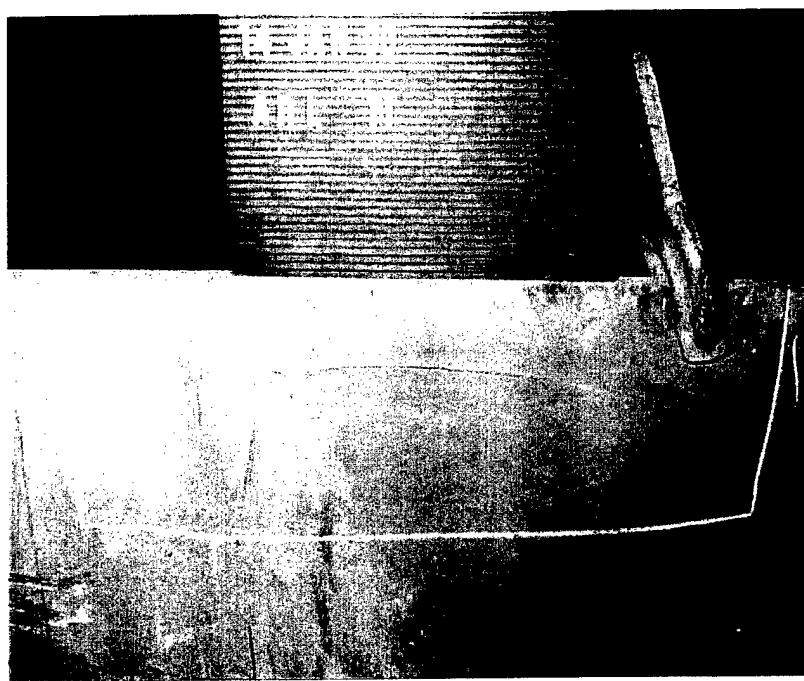

Figure 10. Photograph of the tertiary cracking along the base plate of the ARL test section.

#### 4.1 Discussion of ARL Ballistic Testing

The tertiary fracture occurred first, but is of the least significance. It was ARL's understanding that during the construction of the test section, the base plate needed a lip around the box so it could be held in place on the test stand. A tank turret would not need this lip nor incorporate it in its design. Figure 11 depicts a simple redesign of the front to bottom weld interface that would change the stress configuration, drastically reducing the likelihood of cracking in this area.

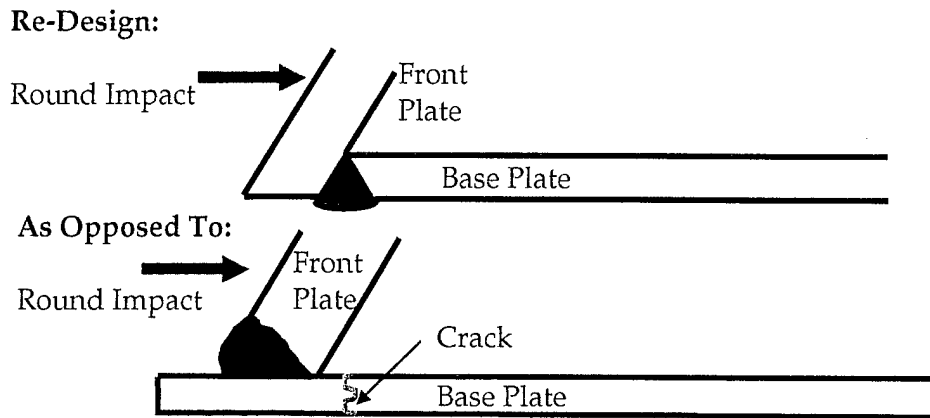

Figure 11. Schematic of the redesigned front to base plate weld joint.

The secondary fracture most likely occurred from a combination of a lack of weld material along the back to base plate interface and the stop/start point of six weld root passes being in the corner of the gusset. A redesign of the welding in this area would result in the entire back plate to base plate interface being welded before the addition of the gusset supports. The fact that the GDLS test section had more weld metal in this area, a very similar weld design, continuous weld beads, and minimal cracking in this area substantiates this (See GDLS Test Section Ballistic Results). The main point here is that ARL believes the cracking originated from a fault in the welding procedure (discontinuous weld beads), not from a fault in the weld design.

The primary fracture occurred as a result of overpressure. This indicates that the weld was not tough (a measure of both strength and ductility) enough to stop cracking from initiating. Preventing crack initiation can eliminate crack progression. The results of the other welds on both the ARL and GDLS test section (in the case of the back plate to bottom plate interface discussed previously) indicate a nearly functional weld process. However, the stresses on the top plate to back plate interface still need to be lowered. In the opinion of ARL, the top plate should be increased in thickness to approximately 1.5 in to allow for a larger weld area to reduce the stress at this interface. It should be noted that the RHA box also had significant cracking (10–15 in) in this area.

## 4.2 Fabrication of the GDLS Test Section

The GDLS test section was fabricated from heat R2494 Timet Ti-6Al-4V material. The exact procedure is not known.

---

## 5. GDLS Test Section Ballistic Results

---

The GDLS test section had its primary fracture originate at the top back LHS of the box, point A in Figure 12.

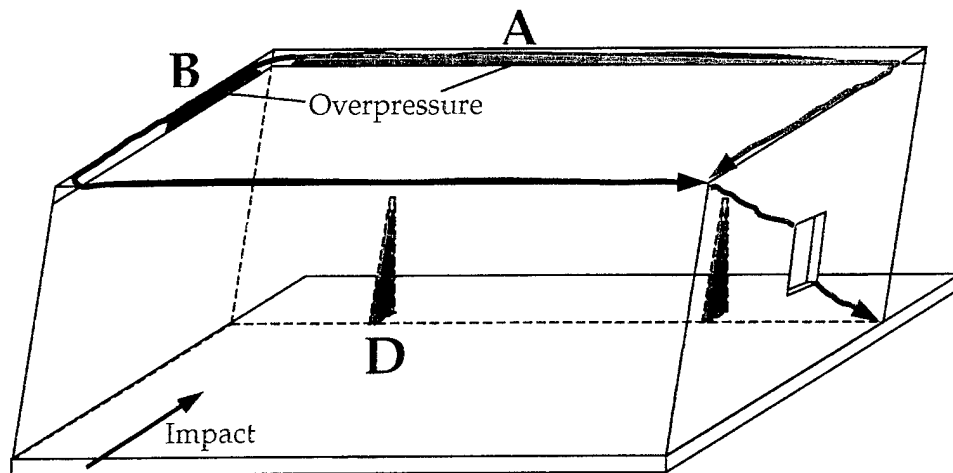

Figure 12. GDLS overview, schematic 1.

It was apparent that the inside surface of the top plate in that area had taken an impact from the armor package. There were linear deformation marks on the inside surface of the top plate that matched the configuration of the armor package. Additionally, the GDLS box weld interface did not match the proposed design of the region, as observed in the picture of the weld failure (see Figures 13 and 14). The top to back plate interface was designed as shown in Figure 13, however; the test section also had an extra step shown.

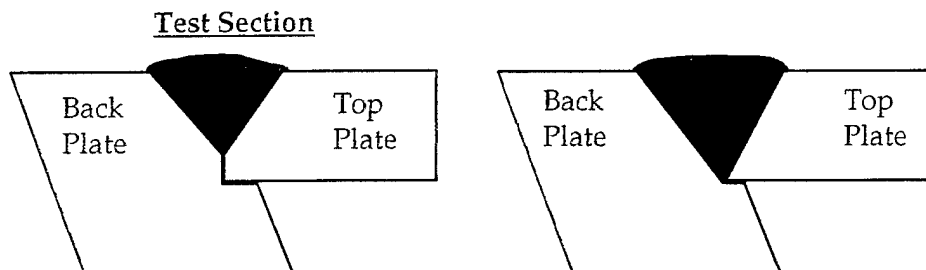

Figure 13. Design of GDLS back to top plate weld vs. test section.

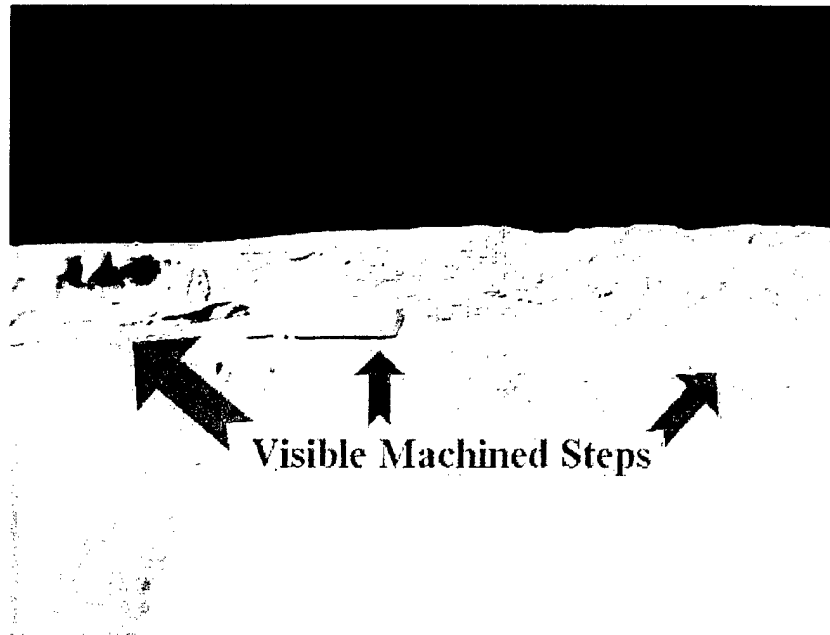

Figure 14. Photograph of the GDLS test section back to top and back to side weld designs.

This extra step was detrimental to the strength of the weld. As a result, the top plate to back plate weld failed from overpressure along a 46-in span along the weld (2/3 of the welded length). The top 1/4–1/2 in of this weld zone failed in shear. There also existed overpressure failure along a 10-in span on the back LHS of the top to side plate interface (see Figure 12, point B). Beyond these regions, the crack paths continued along the top plate welds until both crack fronts met at the top front RHS of the box and the top plate was entirely removed in one piece. A crack then proceeded into the RHS side plate base material, diagonally through the air vent in the RHS side plate, and arrested at the back bottom RHS corner of the test section.

The secondary fracture occurred along the inside back to LHS side plate and back to base plate interfaces. The back to side plate failure originated from overpressure along a 17-in section toward the bottom of that interface (see Figure 15, point C). Cracks progressed along the back to bottom plate weld interface. From the other end of the overpressure zone, cracking advanced into the base material of the LHS side plate until it met the crack path of the top plate from the primary failure (see Figure 15, point D).

Finally, since both sides of the box were in some way fractured, there was nothing to prevent the box from folding back on itself (except the strength of the bottom plate). The gussets supported the back plate, and since the bottom plate was already weakened by the crack along the back plate to bottom plate interface, the bottom plate failed catastrophically at its interface with the back plate (see Figure 16).

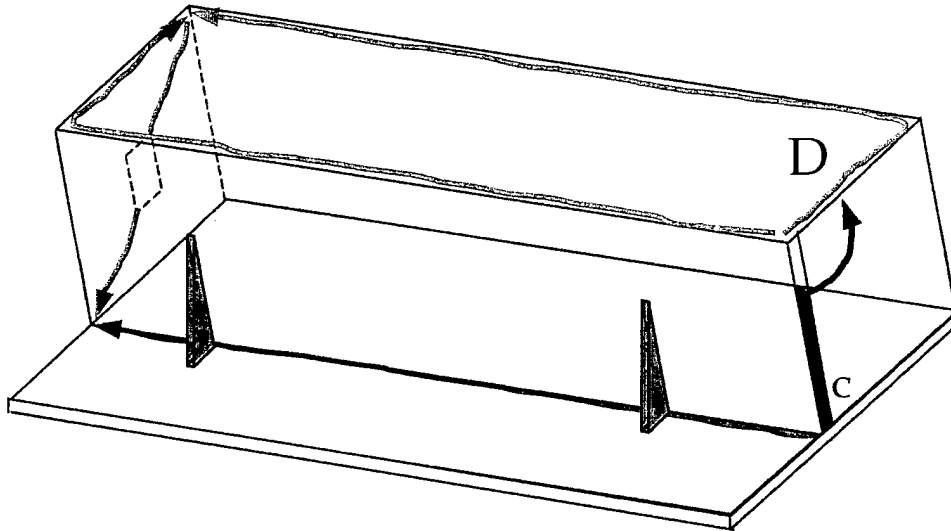

Figure 15. GDLS overview, schematic 2.



Figure 16. Photograph of the GDLS test section failure of the base plate.

### 5.1 Discussion of GDLS Ballistic Testing

Several separate areas of overpressure existed after the shock testing. Some of these areas were also of significant size. The areas where the overpressure mode of failure existed need improvement in the weld toughness and strength. Redesigning the welds, changing the weld material, and/or optimizing the welding process and parameters can accomplish this.

## 5.2 Assessment of ARL Weld Joints

Six of the weld joints were assessed after ballistic testing. Metallography and tensile testing were performed, including both transverse and longitudinal tensile tests. Kroll's reagent was utilized to reveal the grain structure of the base material and the weldment. The multiple pass weld technique can clearly be observed in the photographs. The weldments contained a heat affected zone (HAZ) of approximately 1/8 inch in size bordering the weld fusion zone. The HAZ consisted of equiaxed primary  $\alpha$  and  $\beta$  with some  $\beta$  decomposition products. The weld fusion zone revealed epitaxial grain growth through the multiple passes. The microstructure consisted of retained  $\beta$  and  $\beta$  decomposition products most likely including Widmanstatten  $\alpha$  and  $\beta$ , massive  $\alpha$ , and  $\alpha'$  and  $\alpha''$  martensites, although these were not confirmed through electron microscopy.

Figures 17–21 depict the cross sections of the front plate to top plate weld joint, as shown schematically in Figure 1. Figures 22–26 depict the front to side plate weld cross sections, as shown schematically in Figure 2.

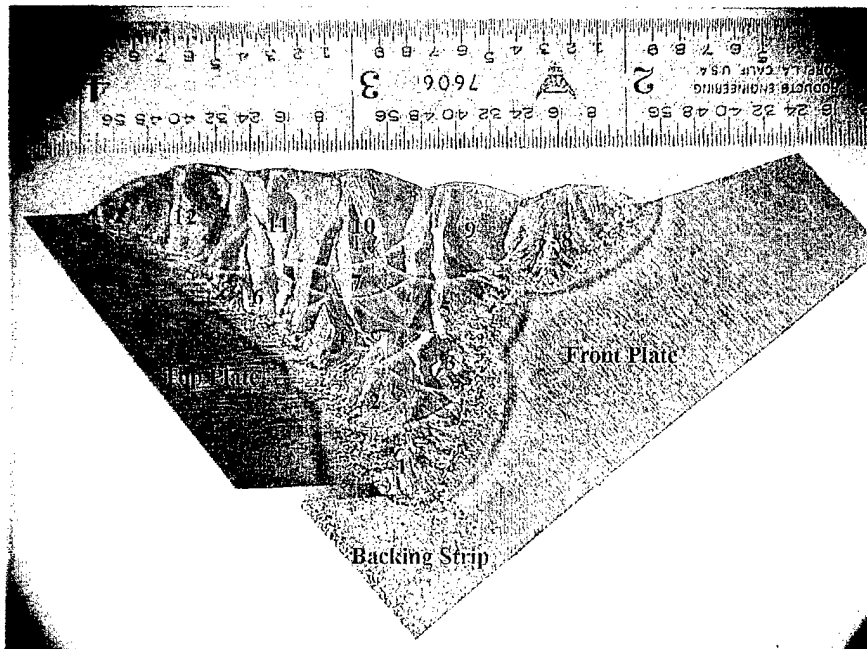

Figure 17. Macro cross section of the front plate to top plate weldment.

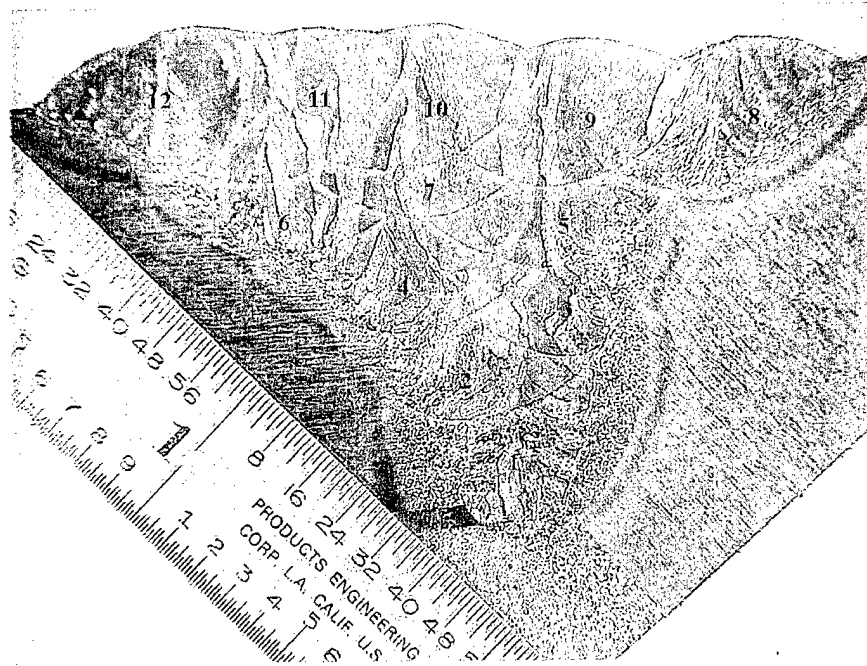

Figure 18. Cross section of the front plate to top plate weld bead.

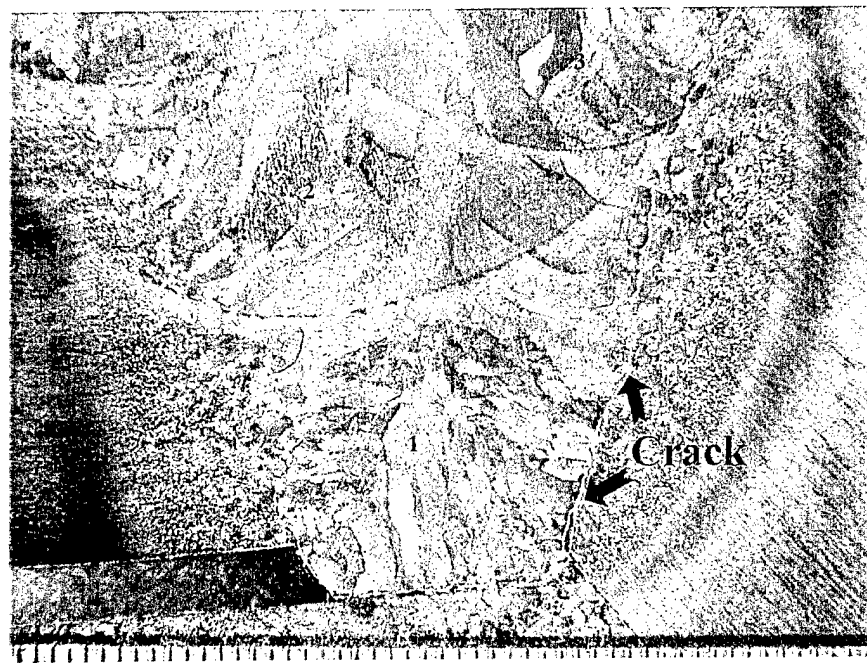

Figure 19. Cross section showing a fine crack in the front plate to top plate weldment.

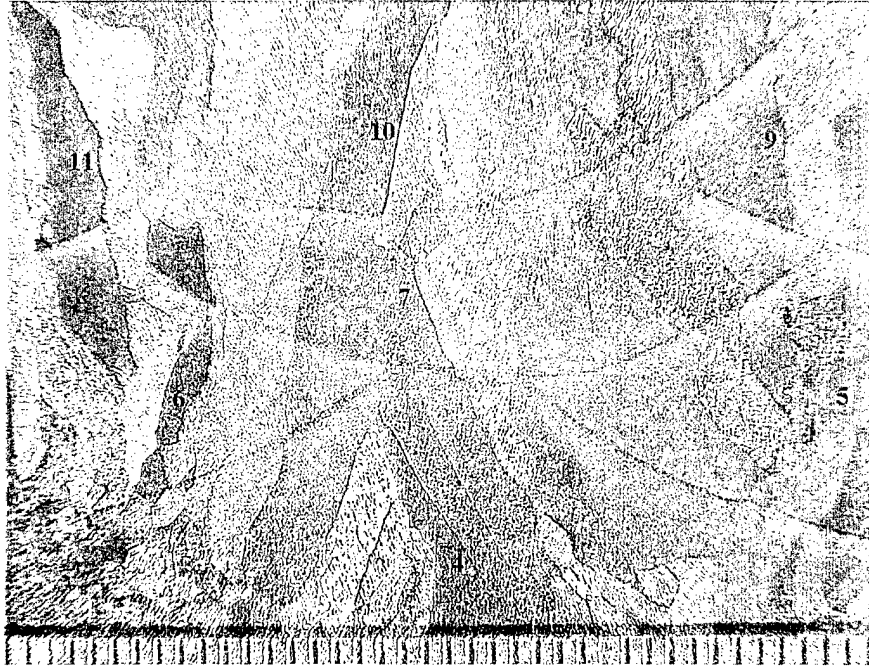

Figure 20. Front to top plate fusion zone with grain growth across weld pass boundaries.

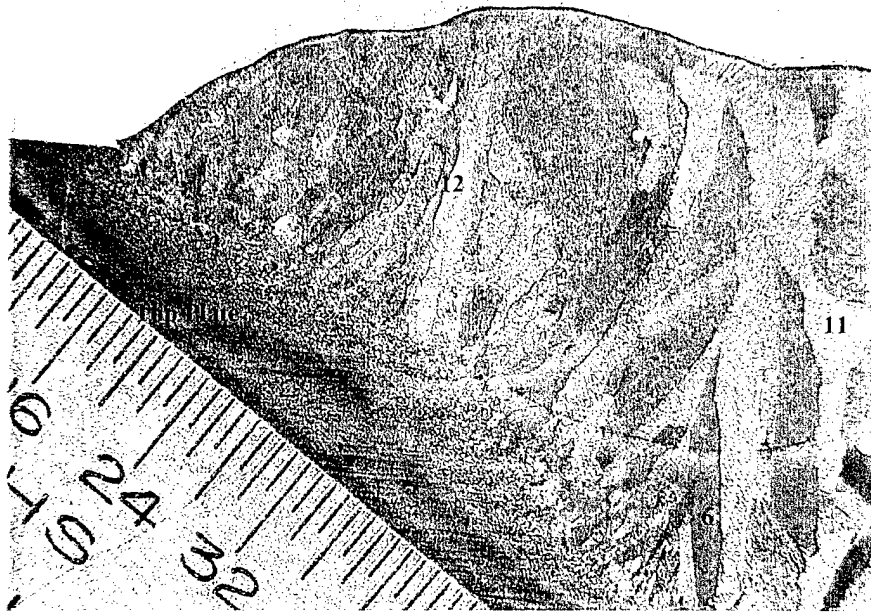

Figure 21. Front plate to top plate weldment showing approximately 1/8-in HAZ.

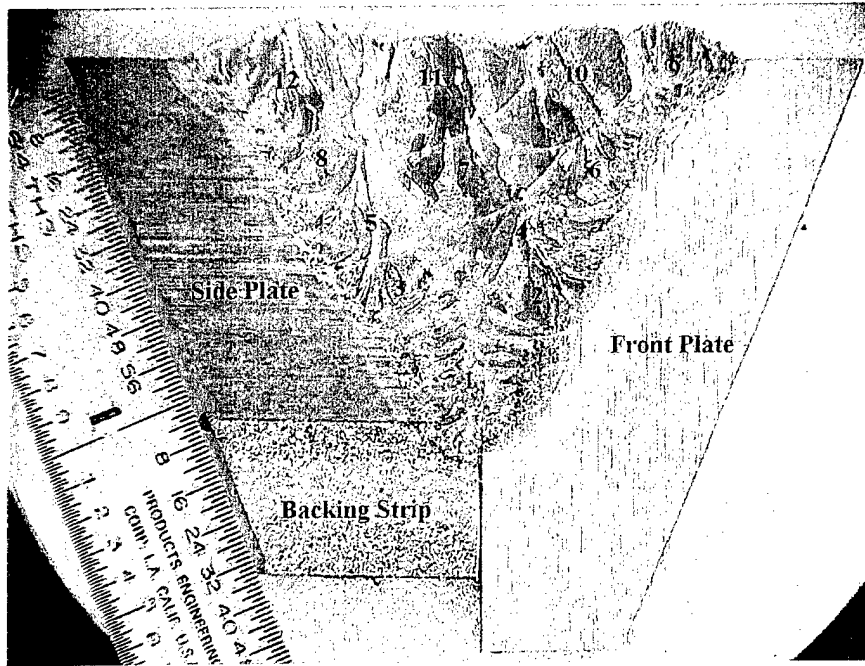

Figure 22. Macro cross section of the front to side plate weldment.

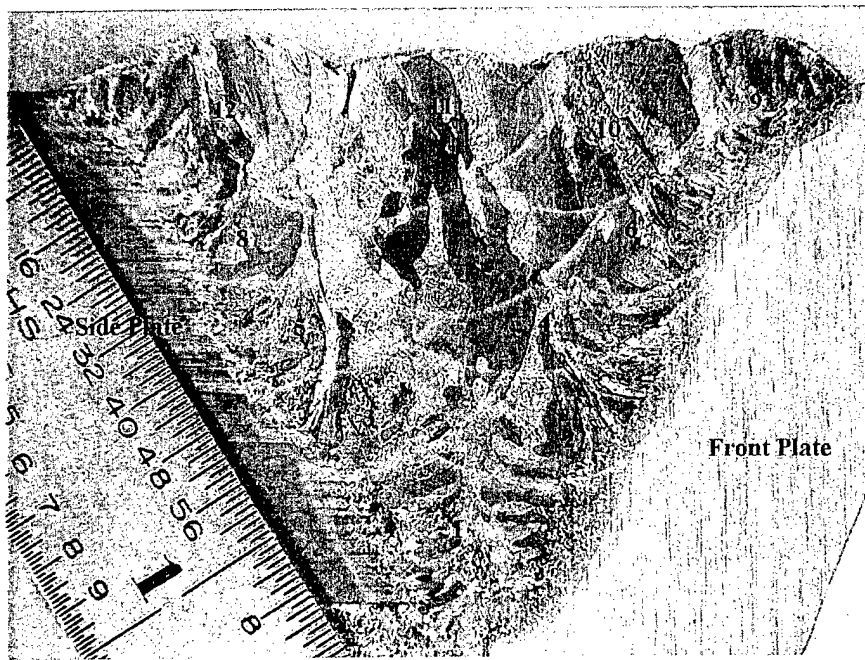

Figure 23. Cross section depicting the front to side plate fusion zone.



Figure 24. Front to side plate weld root.

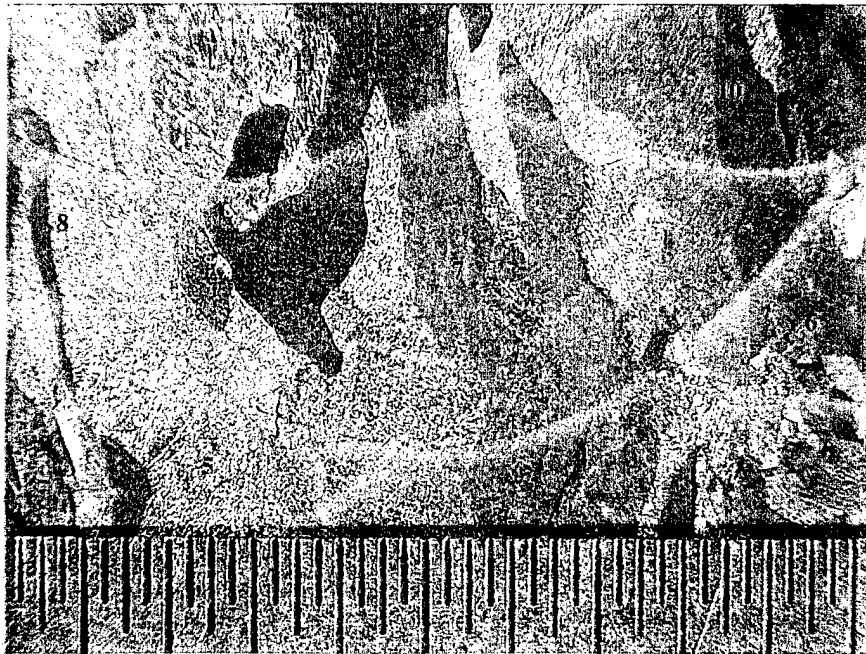

Figure 25. Front to side plate middle of the fusion zone.

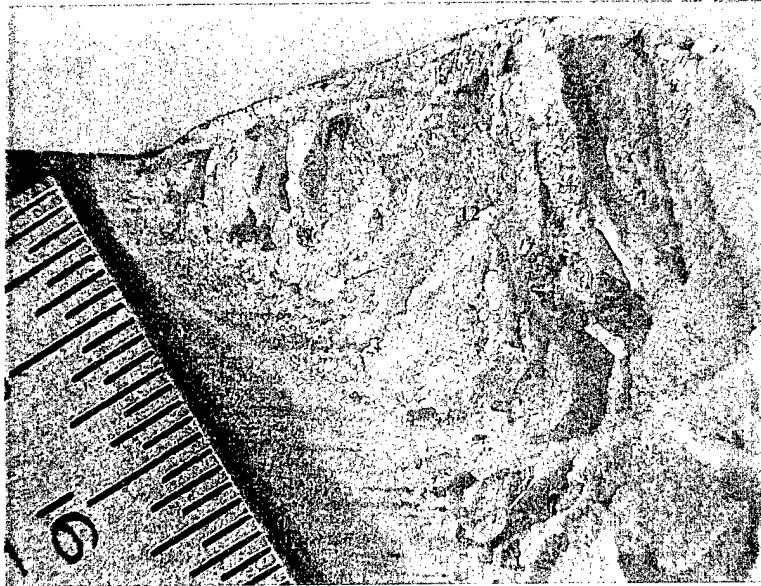

Figure 26. Front to side plate weld cap.

Figures 27–31 depict the front to base plate weld cross sections, as shown schematically in Figure 3, while Figures 32–36 depict the base to top plate weld cross sections, as shown schematically in Figure 4.

Figures 37–41 depict the base to side plate weld cross sections, as shown schematically in Figure 5.

Similarly, Figures 42–46 depict the top to side plate weld cross sections, as shown schematically in Figure 6.

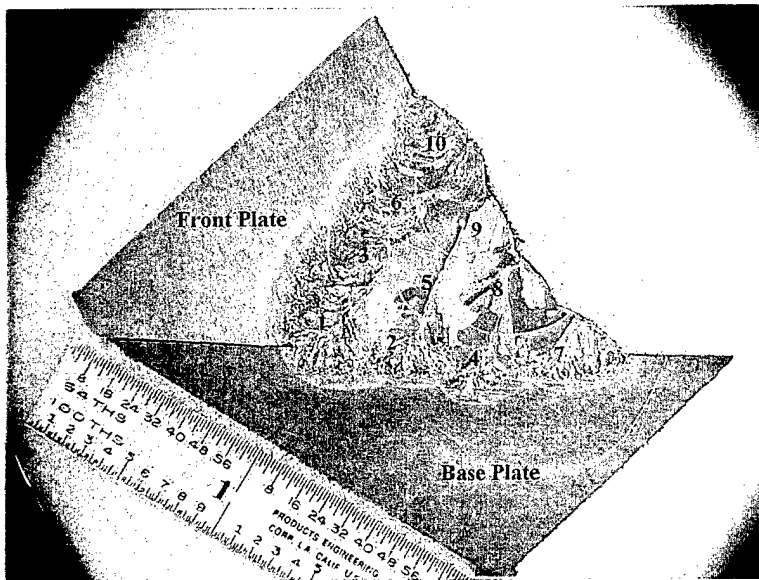

Figure 27. Macro cross section of the front to base plate.

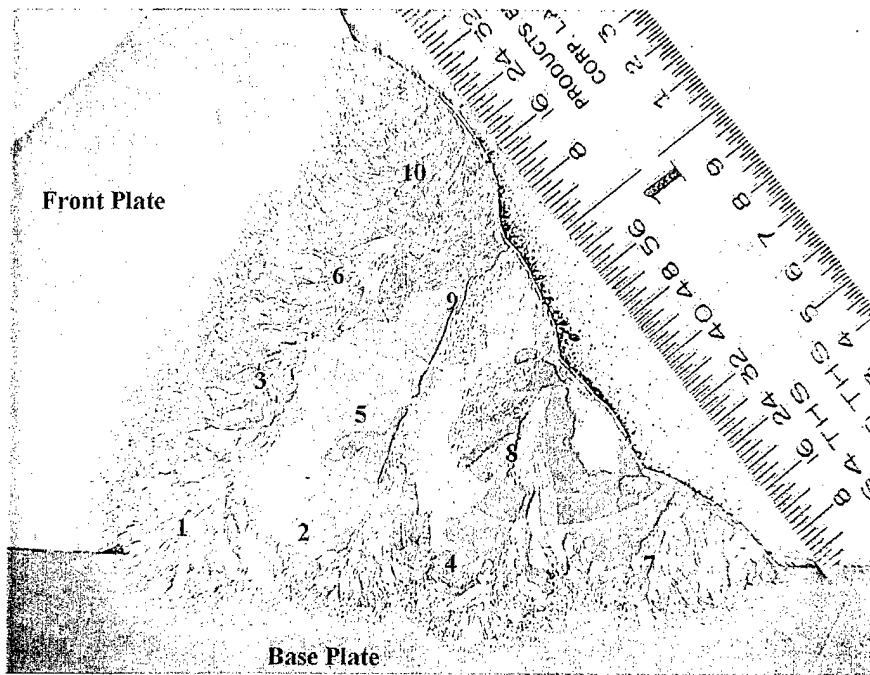

Figure 28. Cross section of the front to base plate fusion zone.

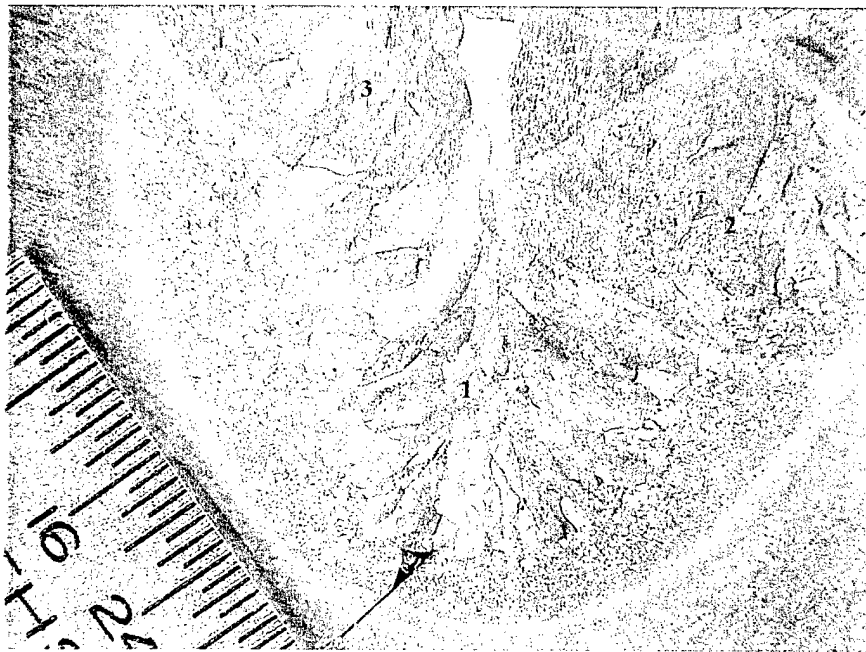

Figure 29. Cross section of the front to base plate weld root.

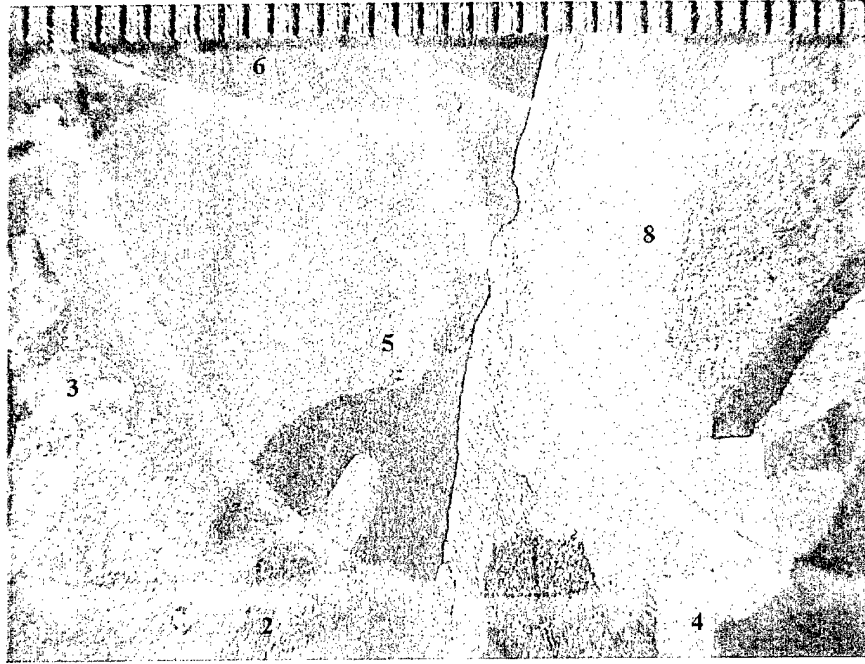

Figure 30. Cross section of the middle of the fusion zone of the front to base plate weld.

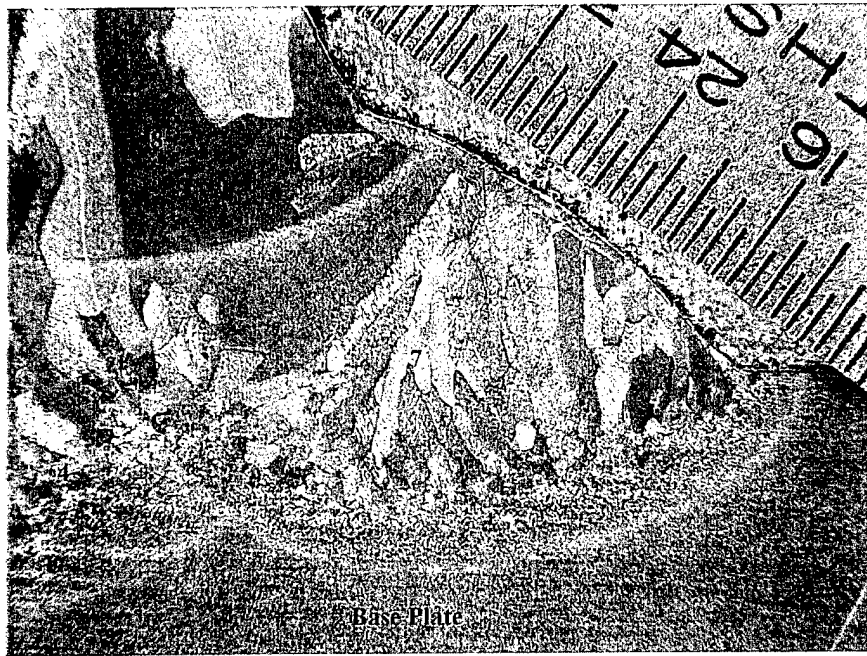

Figure 31. Cross section of the front to base plate weld cap.

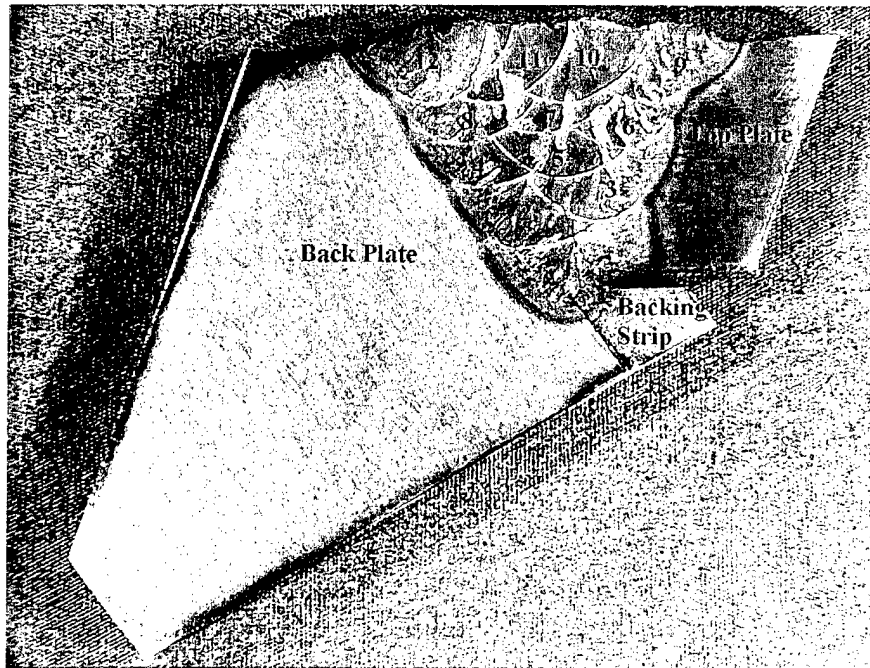

Figure 32. Macro cross section of the back to top plate.

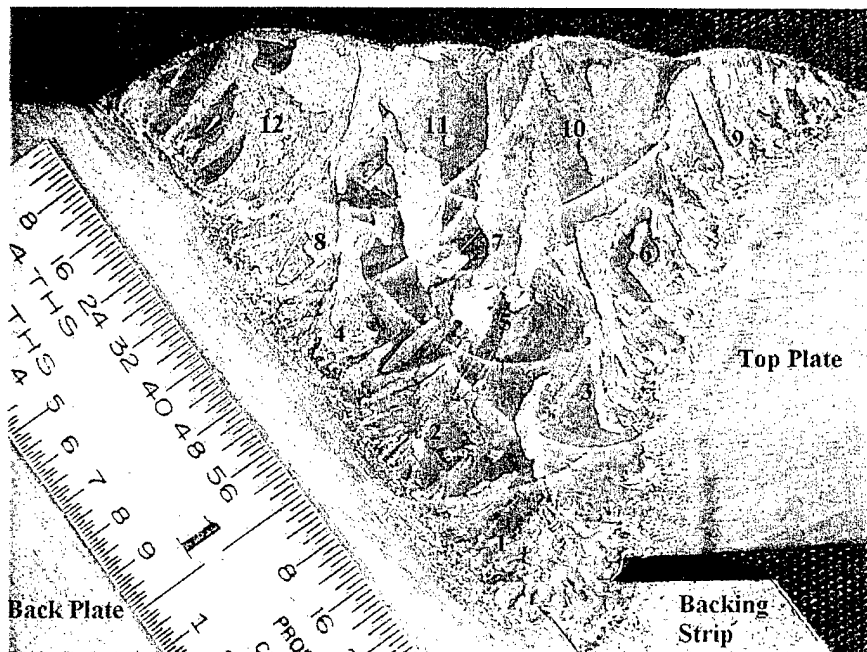

Figure 33. Cross section of the back to top plate weld fusion zone.

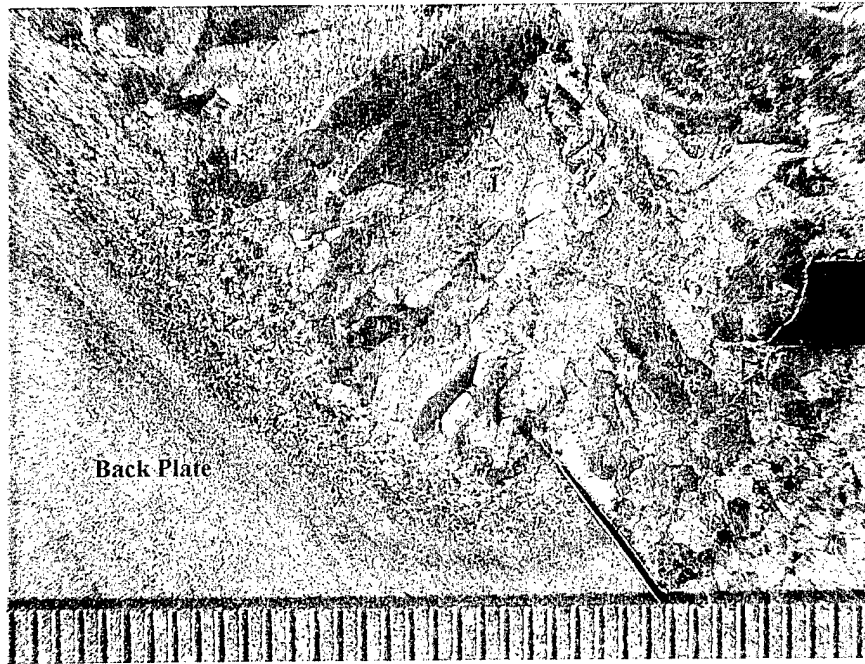

Figure 34. Cross section of the root of the back to top plate weldment.

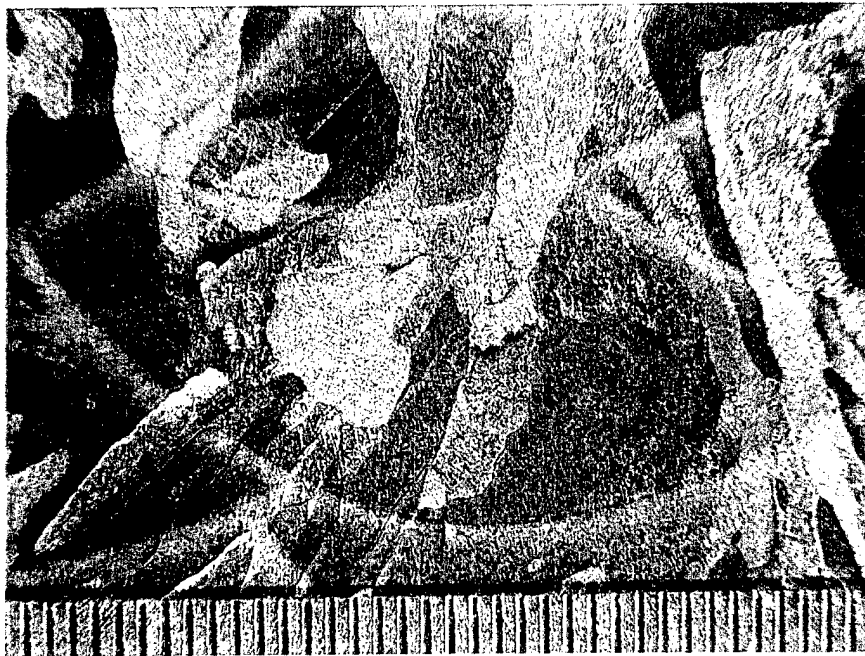

Figure 35. Cross section of the middle of the fusion zone of the back to top plate weldment.

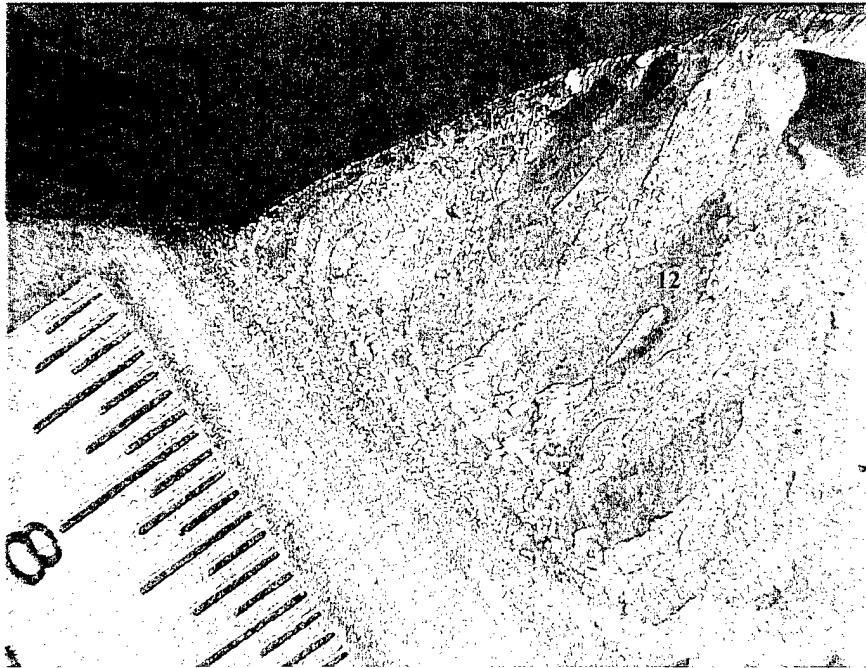

Figure 36. Cross section of the cap of the back to top plate weldment.

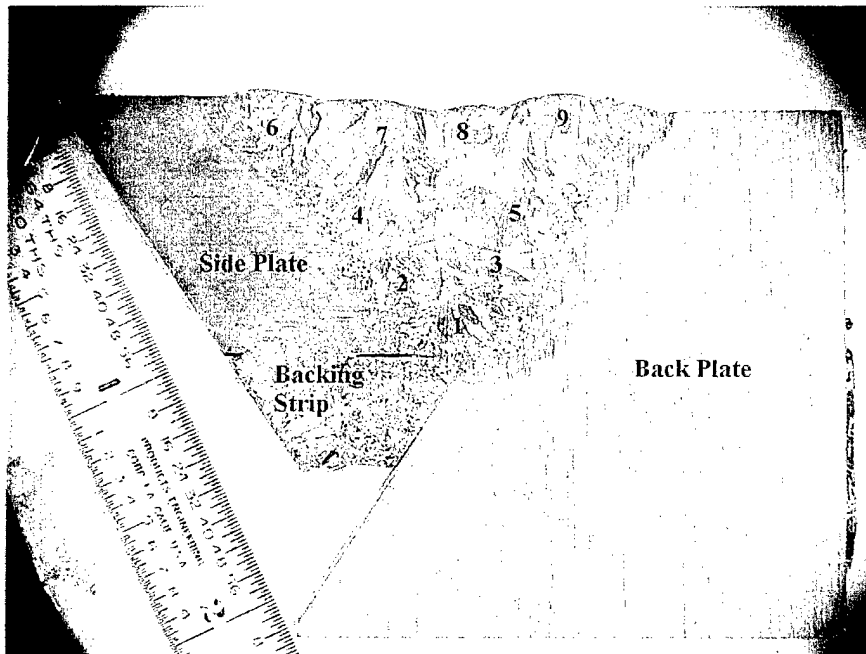

Figure 37. Macro cross section of the base to side plate weldment.

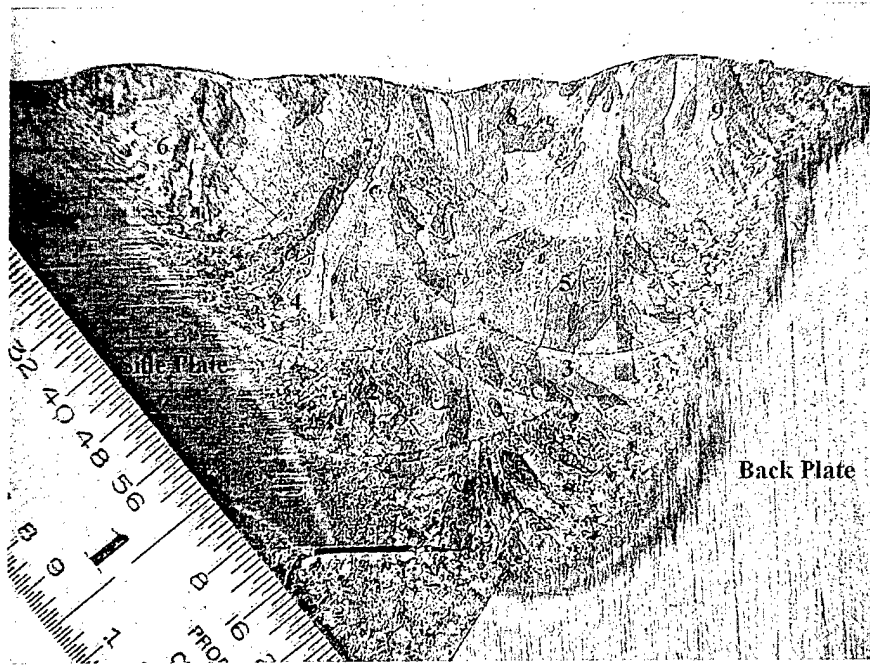

Figure 38. Cross section of the back to side plate weld fusion zone.

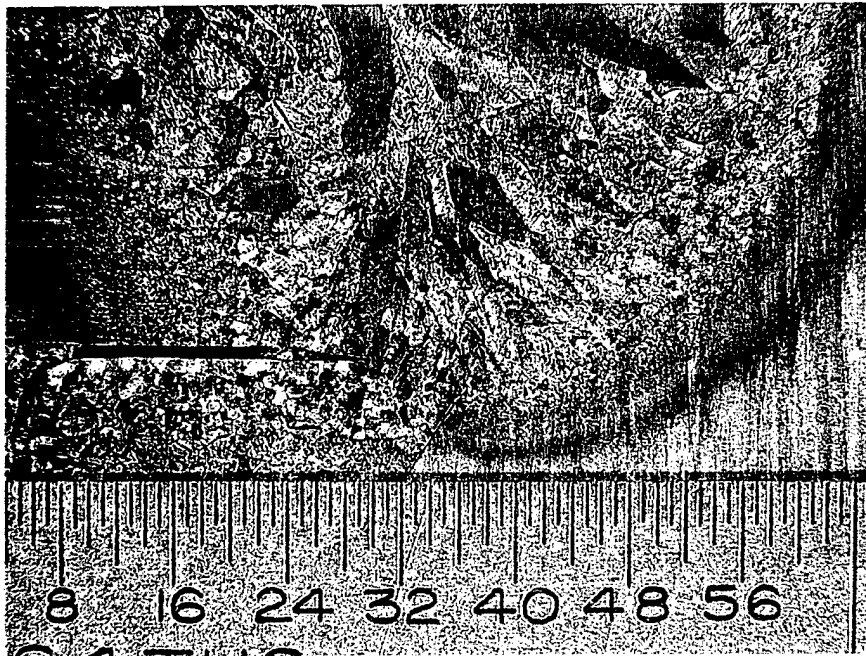

Figure 39. Cross section of the root of the back to side plate weldment.



Figure 40. Cross section of the middle of the back to side plate weld fusion zone.

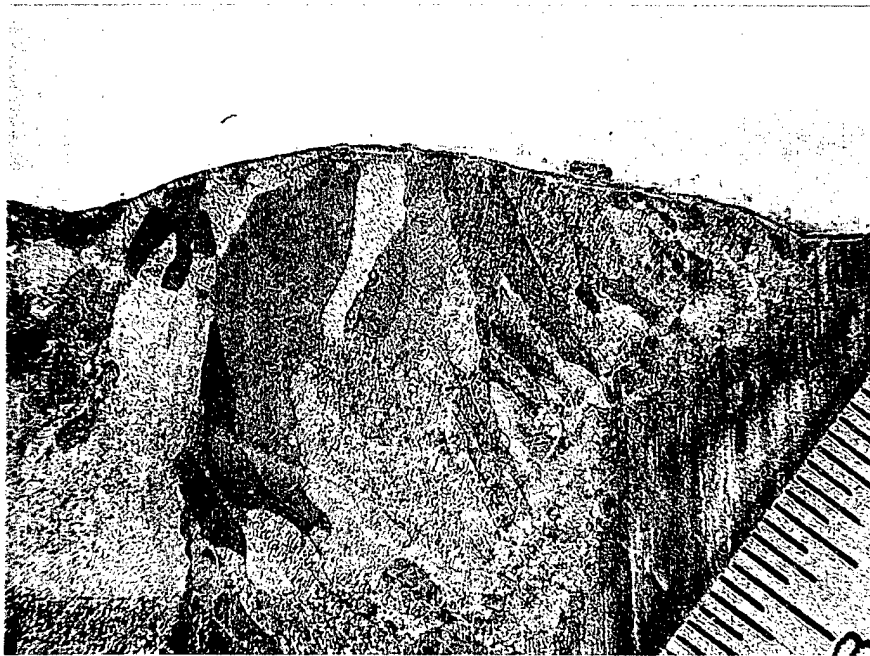

Figure 41. Cross section of the back to side plate weld cap.

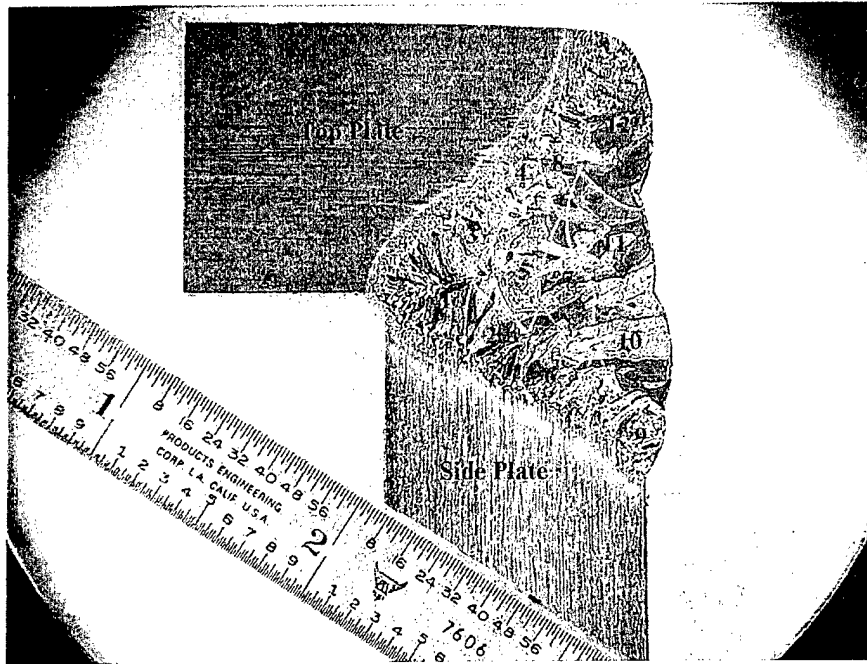

Figure 42. Macro cross section of the top to side plate weldment.

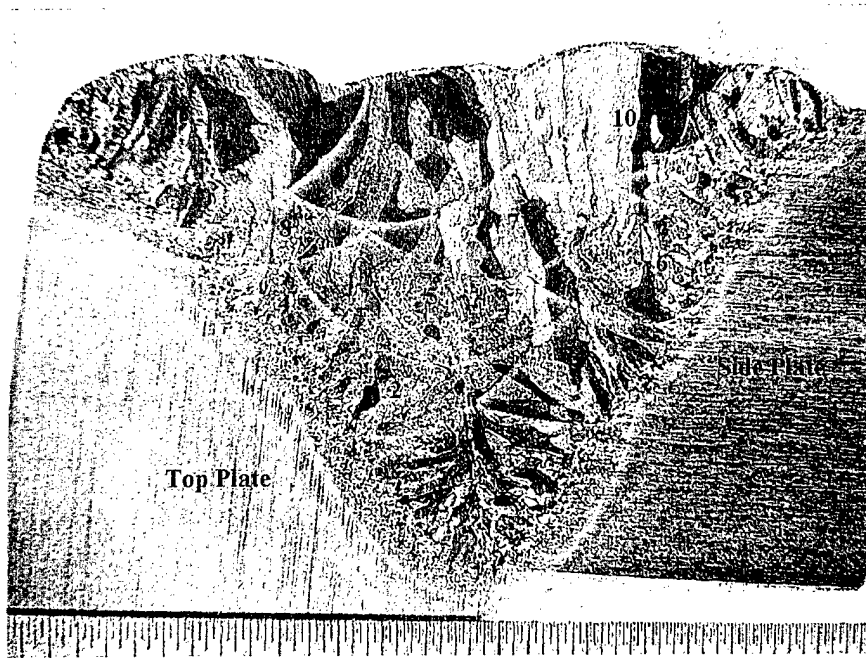

Figure 43. Cross section of the top to side plate weld fusion zone.

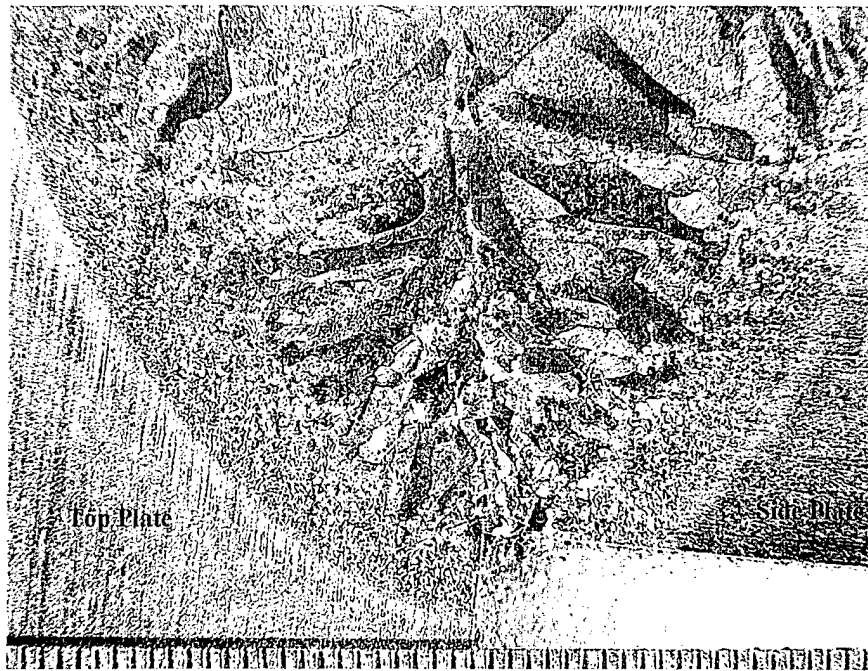

Figure 44. Cross section of the root of the top to side plate weldment.

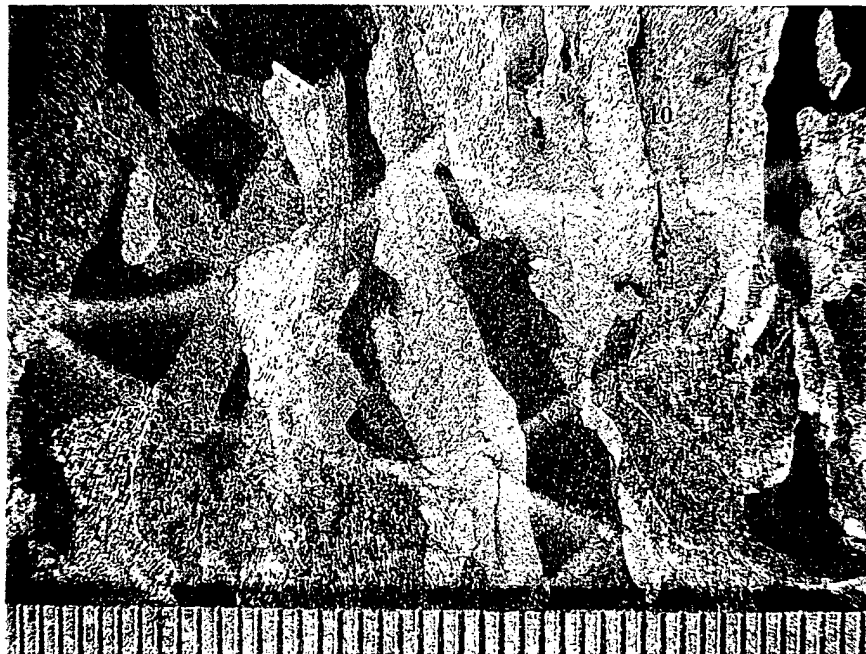

Figure 45. Cross section of the middle of the top to side plate weld fusion zone.

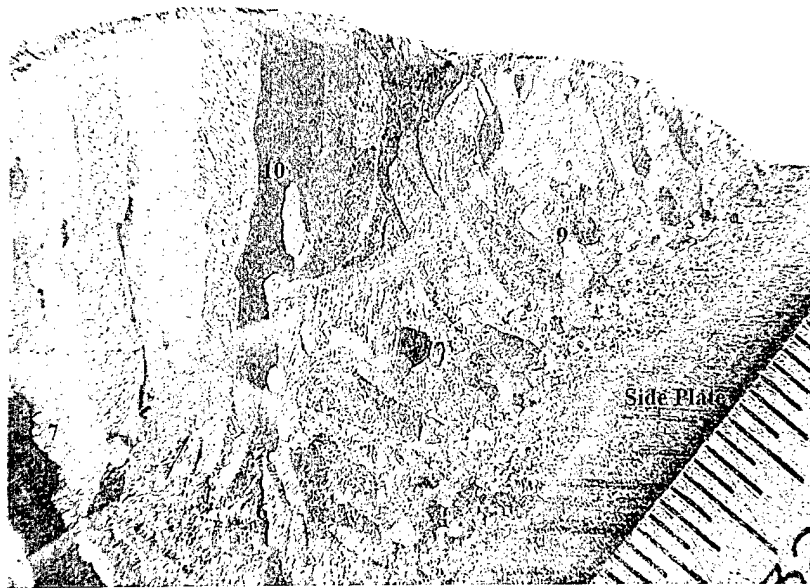

Figure 46. Cross section of the cap of the top to side plate weldment.

## 6. Tensile Testing

Weldments of the ARL test section were set aside for tensile testing. Tensile testing was performed on the weldments of test section in both the longitudinal (all weld metal) and transverse directions. Five specimens were prepared and tested in each direction. Yield strength, tensile strength, elongation, and reduction in area were all recorded. Table 1 depicts the results of the work.

Table 1. Tensile results from the ARL Ti-6-4 test section.

Specimen Number	Diameter (in)	Area (in <sup>2</sup> )	Yield Strength (ksi)	Tensile Strength (ksi)	Elongation (%)	Reduction in Area (%)
Trans. 1	0.252	0.0499	145	148	8	12
Trans. 2	0.252	0.0499	131	147	6	8
Trans. 3	0.252	0.0499	132	148	8	12
Trans. 4	0.252	0.0499	132	150	7	9
Trans. 5	0.252	0.0499	133	151	9	9
Long. 1	0.250	0.0491	130	145	6	9
Long. 2	0.251	0.0495	133	141	7	12
Long. 3	0.252	0.0499	131	143	7	8
Long. 4	0.252	0.0499	128	142	8	16
Long. 5	0.252	0.0499	134	148	9	10

---

## 7. Chemistry

---

The chemistry of the titanium heat utilized to fabricate the material of the test section is included for convenience in Table 2.

Table 2. ARL and GD test section chemistry results for heat R3392 and R2494.

—	Fe	C	N	O	H	Al	V	Sn	Zr	Mo	Cr	Cu	Ni	Pd
R3392	0.016	0.022	0.009	0.175	0	6.15	3.95	0.005	0.003	0.008	0.000	0.003	0.000	0.000
R2494	0.185	0.024	0.009	0.170	0	6.505	3.935	0.005	0.006	0.011	0.000	0.004	0.000	0.000

---

## 8. Conclusions

---

The fabrication and ballistic testing of a titanium test section was completed. The subsequent analysis showed that while there was considerable cracking of some of the weldments, potential exists for using titanium as a tank turret material. While it was not a goal of this program to optimize a welding process for Ti-6Al-4V, the weld design and process utilized by ARL proved more effective than the corresponding GDLS design and process. Based upon the fact that both titanium test sections and the RHA test section cracked significantly when subjected to the shock round, it is suggested that more optimization work is needed for both the design of the weld joints and the welding process for titanium. However, the effort should not be abandoned based on these results.

<u>NO. OF COPIES</u>	<u>ORGANIZATION</u>
2	DEFENSE TECHNICAL INFORMATION CENTER DTIC OCA 8725 JOHN J KINGMAN RD STE 0944 FT BELVOIR VA 22060-6218
1	HQDA DAMO FDT 400 ARMY PENTAGON WASHINGTON DC 20310-0460
1	OSD OUSD(A&T)/ODDR&E(R) DR R J TREW 3800 DEFENSE PENTAGON WASHINGTON DC 20301-3800
1	COMMANDING GENERAL US ARMY MATERIEL CMD AMCRDA TF 5001 EISENHOWER AVE ALEXANDRIA VA 22333-0001
1	INST FOR ADVNCD TCHNLGY THE UNIV OF TEXAS AT AUSTIN 3925 W BRAKER LN STE 400 AUSTIN TX 78759-5316
1	DARPA SPECIAL PROJECTS OFFICE J CARLINI 3701 N FAIRFAX DR ARLINGTON VA 22203-1714
1	US MILITARY ACADEMY MATH SCI CTR EXCELLENCE MADN MATH MAJ HUBER THAYER HALL WEST POINT NY 10996-1786
1	DIRECTOR US ARMY RESEARCH LAB AMSRL D DR D SMITH 2800 POWDER MILL RD ADELPHI MD 20783-1197

<u>NO. OF COPIES</u>	<u>ORGANIZATION</u>
1	DIRECTOR US ARMY RESEARCH LAB AMSRL CI AI R 2800 POWDER MILL RD ADELPHI MD 20783-1197
3	DIRECTOR US ARMY RESEARCH LAB AMSRL CI LL 2800 POWDER MILL RD ADELPHI MD 20783-1197
3	DIRECTOR US ARMY RESEARCH LAB AMSRL CI IS T 2800 POWDER MILL RD ADELPHI MD 20783-1197
	<u>ABERDEEN PROVING GROUND</u>
2	DIR USARL AMSRL CI LP (BLDG 305)

NO. OF  
COPIES ORGANIZATION

3 PM CRUSADER  
SFAE GCSS CR E  
BLDG 171A  
B ROOPCHAND  
PICATINNY ARSENAL NJ  
07806-5000

ABERDEEN PROVING GROUND

30 DIR USARL  
AMSRL WM MD  
S GREND AHL

REPORT DOCUMENTATION PAGE			Form Approved OMB No. 0704-0188	
Public reporting burden for this collection of information is estimated to average 1 hour per response, including the time for reviewing instructions, searching existing data sources, gathering and maintaining the data needed, and completing and reviewing the collection of information. Send comments regarding this burden estimate or any other aspect of this collection of information, including suggestions for reducing this burden, to Washington Headquarters Services, Directorate for Information Operations and Reports, 1215 Jefferson Davis Highway, Suite 1204, Arlington, VA 22202-4302, and to the Office of Management and Budget, Paperwork Reduction Project(0704-0188), Washington, DC 20503.				
1. AGENCY USE ONLY (Leave blank)		2. REPORT DATE June 2001	3. REPORT TYPE AND DATES COVERED Final, January 1999–September 2000	
4. TITLE AND SUBTITLE Fabrication and Evaluation of Welded Ti-6Al-4V Test Sections			5. FUNDING NUMBERS 622105AH84	
6. AUTHOR(S) Scott Grendahl, Daniel Snoha, and Brijmohan Roopchand*				
7. PERFORMING ORGANIZATION NAME(S) AND ADDRESS(ES) U.S. Army Research Laboratory ATTN: AMSRL-WM-MD Aberdeen Proving Ground, MD 21005-5069			8. PERFORMING ORGANIZATION REPORT NUMBER ARL-TR-2533	
9. SPONSORING/MONITORING AGENCY NAMES(S) AND ADDRESS(ES)  U.S. Army Tank-automotive and Armaments Command, Heavy Combat Systems Business Unit, AMSTA-TR, Warren, MI 48397-5000			10. SPONSORING/MONITORING AGENCY REPORT NUMBER	
11. SUPPLEMENTARY NOTES *U.S. Army Armament Research, Development, and Engineering Center, Picatinny Arsenal, NJ 07806				
12a. DISTRIBUTION/AVAILABILITY STATEMENT Approved for public release; distribution is unlimited.			12b. DISTRIBUTION CODE	
13. ABSTRACT (Maximum 200 words)  There has been wide support for the continued reduction in weight of heavy armor combat systems. Of course no one is willing to give up performance with this reduction in weight. This program investigated the feasibility of utilizing Ti-6Al-4V as an alternate armor material for the M1 Abrams turret glacis as opposed to the presently utilized RHA steel. Two turret glacis test sections were fabricated from Ti-6Al-4V armor plate, and one was fabricated from RHA steel. These sections were ballistic tested vs. common threats. The weld joint design is described from a theoretical basis as well as functional performance. The ballistic results of all test sections are discussed in detail, and recommendations for future work are provided.				
14. SUBJECT TERMS titanium, welding, mechanical tests, ballistic testing			15. NUMBER OF PAGES 38	
			16. PRICE CODE	
17. SECURITY CLASSIFICATION OF REPORT UNCLASSIFIED	18. SECURITY CLASSIFICATION OF THIS PAGE UNCLASSIFIED	19. SECURITY CLASSIFICATION OF ABSTRACT UNCLASSIFIED	20. LIMITATION OF ABSTRACT UL	

INTENTIONALLY LEFT BLANK.

**USER EVALUATION SHEET/CHANGE OF ADDRESS**

This Laboratory undertakes a continuing effort to improve the quality of the reports it publishes. Your comments/answers to the items/questions below will aid us in our efforts.

- 1. ARL Report Number/Author ARL-TR-2533 (Grendahl) Date of Report June 2001
- 2. Date Report Received \_\_\_\_\_
- 3. Does this report satisfy a need? (Comment on purpose, related project, or other area of interest for which the report will be used.) \_\_\_\_\_  
\_\_\_\_\_
- 4. Specifically, how is the report being used? (Information source, design data, procedure, source of ideas, etc.) \_\_\_\_\_  
\_\_\_\_\_
- 5. Has the information in this report led to any quantitative savings as far as man-hours or dollars saved, operating costs avoided, or efficiencies achieved, etc? If so, please elaborate. \_\_\_\_\_  
\_\_\_\_\_
- 6. General Comments. What do you think should be changed to improve future reports? (Indicate changes to organization, technical content, format, etc.) \_\_\_\_\_  
\_\_\_\_\_  
\_\_\_\_\_

CURRENT ADDRESS	_____
	Organization
	_____
	Name <span style="float: right;">E-mail Name</span>
	_____
	Street or P.O. Box No.
	_____
	City, State, Zip Code

7. If indicating a Change of Address or Address Correction, please provide the Current or Correct address above and the Old or Incorrect address below.

OLD ADDRESS	_____
	Organization
	_____
	Name
	_____
	Street or P.O. Box No.
	_____
	City, State, Zip Code

(Remove this sheet, fold as indicated, tape closed, and mail.)  
**(DO NOT STAPLE)**