

AFRL-ML-TY-TP-2001-0031



**Recirculating Ventilation System
in an Integrated Maintenance Hangar
Supporting B-1B and KC-135 Aircraft**

Joseph D. Wander
Air Force Research Laboratory
139 Barnes Drive, Suite 2
Tyndall AFB, FL 32403-5323

Brian S. Adams, Stephen T. Gibbs
366 CE/CECM
1030 Liberator Street
Mountain Home AFB, ID 83648-5442

Christopher A. Williston
366 AMDS/SGPB
90 Hope Drive
Mountain Home AFB, ID 83648-1000

Approved for Public Release; Distribution Unlimited

**AIR FORCE RESEARCH LABORATORY
MATERIALS & MANUFACTURING DIRECTORATE
AIR EXPEDITIONARY FORCES TECHNOLOGIES DIVISION
139 BARNES DRIVE, STE 2
TYNDALL AFB FL 32403-5323**

20010806 115

NOTICES

USING GOVERNMENT DRAWINGS, SPECIFICATIONS, OR OTHER DATA INCLUDED IN THIS DOCUMENT FOR ANY PURPOSE OTHER THAN GOVERNMENT PROCUREMENT DOES NOT IN ANY WAY OBLIGATE THE US GOVERNMENT. THE FACT THAT THE GOVERNMENT FORMULATED OR SUPPLIED THE DRAWINGS, SPECIFICATIONS, OR OTHER DATA DOES NOT LICENSE THE HOLDER OR ANY OTHER PERSON OR CORPORATION; OR CONVEY ANY RIGHTS OR PERMISSION TO MANUFACTURE, USE, OR SELL ANY PATENTED INVENTION THAT MAY RELATE TO THEM.

THIS TECHNICAL PAPER HAS BEEN REVIEWED AND IS APPROVED FOR PUBLICATION. ORIGINALLY PRESENTED TO THE 94th ANNUAL MEETING AND EXHIBITION, AIR & WASTE MANAGEMENT ASSOCIATION, ORLANDO, FLORIDA, 26 JUNE 2001. *PROCEEDINGS OF THE AIR & WASTE MANAGEMENT ASSOCIATION'S 94th ANNUAL CONFERENCE & EXHIBITION* IS AVAILABLE AS A CD-ROM FROM WWW.AWMA.ORG



JOSEPH D. WANDER, Ph.D
Program Manager



LYNN L. BORLAND, Major, USAF, BSC
Chief, Weapons Systems Logistics Branch

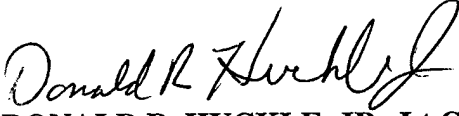

DONALD R. HUCKLE, JR., Lt Col, USAF
Chief, Air Expeditionary Forces Technologies Division

This report is published in the interest of scientific and technical information exchange and does not constitute approval or disapproval of its ideas or findings.

Do not return copies of this report unless contractual obligations or notice on a specific document requires its return.

REPORT DOCUMENTATION PAGE

Form Approved
OMB No. 0704-0188

Public reporting burden for this collection of information is estimated to average 1 hour per response, including the time for reviewing instructions, searching existing data sources, gathering and maintaining the data needed, and completing and reviewing the collection of information. Send comments regarding this burden estimate or any other aspect of this collection of information, including suggestions for reducing this burden, to Washington Headquarters Services, Directorate for Information Operations and Reports, 1215 Jefferson Davis Highway, Suite 1204, Arlington, VA 22202-4302, and to the Office of Management and Budget, Paperwork Reduction Project (0704-0188), Washington, DC 20503.

1. AGENCY USE ONLY (Leave blank)		2. REPORT DATE 26 June 2001	3. REPORT TYPE AND DATES COVERED Meeting abstract / 990901-010531	
4. TITLE AND SUBTITLE Recirculating Ventilation System in an Integrated Maintenance Hangar Supporting B-1B and KC-135 Aircraft			5. FUNDING NUMBERS Uncontracted work supported by MHAFB O&M funds	
6. AUTHORS Joseph D. Wander, Brian S. Adams, Stephen T. Gibbs, and Christopher A. Williston				
7. PERFORMING ORGANIZATION NAME(S) AND ADDRESS(ES) 366 AMDS/SGPB 90 Hope Drive Mountain Home AFB, ID 83648-1000			8. PERFORMING ORGANIZATION REPORT NUMBER	
9. SPONSORING/MONITORING AGENCY NAME(S) AND ADDRESS(ES) AFRL/MLQL 139 Barnes Drive, Suite 2 Tyndall AFB, FL 32403-5323			10. SPONSORING/MONITORING AGENCY REPORT NUMBER AFRL-ML-TY-TP-2001-0031	
11. SUPPLEMENTARY NOTES Technical monitor: Dr Joe Wander, AFRL/MLQL, 850-283-6240 [DSN 523-6240] Presented 010626, in <i>Proceedings 94th Annual Conference, Air & Waste Management Association, Orlando</i>				
12a. DISTRIBUTION/AVAILABILITY STATEMENT Distribution unlimited.			12b. DISTRIBUTION CODE A	
13. ABSTRACT (Maximum 200 words) During 1998 the Corps of Engineers (CoE) built an integrated maintenance hangar (Building 198) to support maintenance of B-1B and KC-135 aircraft at Mountain Home Air Force Base (MHAFB). Recirculation of 80% of the exhaust air was included in the design as an energy conservation measure, and carbon adsorption was applied to the exhaust stream to capture VOCs. Routine Industrial Hygiene exposure sampling for chromate and for isocyanates was conducted by MHAFB staff during application of prime and top coats, respectively, and all measurements were below the repetitive method detection limits. However, although the CoE design delivered provided strong air movement in most areas inside the hangar, the ventilation field included many regions of intense turbulence, in which the application of paint is difficult. Some amelioration of turbulence was accomplished by adjustment of baffles and vents at the exits from the ventilation ducts, and the hangar is now in routine use, setting a concrete precedent for operating in Recirculating ventilation mode under the <i>de minimis</i> "violation" defined by OSHA and applied to 29 CFR 1910.107 (d) (9). [MHAFB is planning an eventual hangar modification project to relocate the ventilation intakes and exhaust, to even out the airflow pattern.]				
14. SUBJECT TERMS solvent, spray painting, recirculation, ventilation, exposure, heating, energy conservation			15. NUMBER OF PAGES 17	
			16. PRICE CODE	
17. SECURITY CLASSIFICATION OF REPORT UNCLASSIFIED	18. SECURITY CLASSIFICATION OF THIS PAGE UNCLASSIFIED	19. SECURITY CLASSIFICATION OF ABSTRACT UNCLASSIFIED	20. LIMITATION OF ABSTRACT UL	

NSN 7540-01-280-5500

Computer Generated

STANDARD FORM 298 (Rev 2-89)
Prescribed by ANSI Std Z39-18
298-102

Recirculating Ventilation System in an Integrated Maintenance Hangar Supporting B-1B and KC-135 Aircraft

Paper # 710

Joseph D. Wander

AFRL/MLQL, 139 Barnes Drive, Suite 2, Tyndall AFB, Florida 32403-5323

Brian S. Adams, Stephen T. Gibbs

366 CE/CECM, 1030 Liberator Street, Mountain Home AFB, Idaho 83648-5442

Christopher A. Williston

366 AMDS/SGPB, 90 Hope Drive, Mountain Home AFB, Idaho 83648-1000

ABSTRACT

Dividing the filtered exhaust from a large spray-painting facility and returning a portion of it in the intake stream is a simple, direct way to recover energy used to condition outdoor air. Under conditions of proper design, operation, and maintenance, returning contaminants are so diluted that workers' health risks are not measurably affected. OSHA has acknowledged that 29 CFR 1910.107 (d) (9) is not a basis for a citation.

Mountain Home Air Force Base, which heats extensively during eight months each year, is operating a large-aircraft maintenance facility in which 80% of 260 kcfm of ventilation air that is filtered and passed through a carbon adsorption bed is recirculated into the hangar with 50 kcfm of conditioned fresh air. The balance [~2 kcfm] infiltrates to keep the facility at negative pressure. Annual energy savings to ventilate 17 hours/week are estimated at \$20–40K, depending on the fraction of energy consumed as electricity. The treatment also attenuates VOC emissions from the facility by an order of magnitude, relieving pressure on the base's permitted limit.

Excepting a number of inconclusive chromium samples, all occupational exposure samples measured during coating-related activities have been below method detection limits that were smaller than the OEL, and the facility is approved to operate without restriction. Coating application is not uniform—owing to extreme deviations from laminarity of the airflow—but usable, and the facility now runs at design capacity, while continuing efforts incrementally improve patterns of airflow.

This paper describes the design and function of the hangar, with emphasis on the ventilation system, a method of estimating energy costs, occupational exposure

measurements and applicable standards, and lessons of general interest for organizations considering installing or modifying an aircraft painting facility.

INTRODUCTION

The design of fixed-wing aircraft requires that conventional enclosed structures in which they are maintained be very large to accommodate the plane and allow room for free movement of painters and other maintenance personnel. Airflows of the order of magnitude of Mcfm are required to achieve uniform ventilation of such facilities at 100 ft/min as specified in 29 CFR 1910.94 (c)(6)(i) and 1910.107 (b)(5). Heating, ventilation, and air-conditioning (HVAC) costs vary with location, but are proportional to the total volume of air handled, and contribute significantly to the cost of aircraft maintenance.

Pollutant air emissions from aircraft spray painting operations are regulated under Title III of the Clean Air Act as amended in 1990 and subsequently implemented in the aerospace coatings NESHAP.¹ Efficient filtration of particulate contaminants is required. However, facilities have a choice about volatile organic compounds (VOCs): they may (1) apply a technology to remove and destroy 81% or more of the VOCs in the traditional coating, or (2) accept some compromise of the properties of the coating and apply *compliant materials* (coatings containing less than a specified amount of VOC). In areas that are not in attainment with CAA Title I ozone standards, it may be significant to compliance strategies that a controlled process emits less than half as much VOC as the corresponding operation conducted with low-VOC coatings.

Life-cycle cost—the total cost from inception to disposal—has evolved into a determining consideration for the military. *E.g.*, DoD Directive 5000.1 (now 10 years old) repeatedly calls for intelligent management of risks to achieve economy. Implementation of alternative ventilation methods in large painting facilities offers significant reductions to the cost of aircraft maintenance, consistent with DoD's guidance. Three approaches to decreasing ventilation costs will be considered below:

Local Ventilation

Painting is a local operation, conducted by one or a few painters working at sufficient separation to avoid contaminating each other with oversprayed coating material. The toxicity of these materials is considered sufficient that both civilian and military regulations mandate elaborate personal protective clothing and equipment (PPE), including an independent supply of breathing air, for personnel in the area. Global dilution of the narrow region of contamination propagating downwind from the painter results in a huge volume of slightly contaminated air in the exhaust. An obvious approach is to contain only the immediate vicinity in which painting is actively conducted, which would decrease the ventilation cross-section by two orders of magnitude. Indeed, a 1991 patent² describes such a system, but engineering requirements to control movement of the enclosure and to contain the airborne contaminants present formidable challenges to implementation of this concept.

Exhaust Recirculation

Because the principal toxicants [chromium in primers and isocyanates in topcoats] are effectively involatile, exhaust filters complying with the NESHAP standard capture ~99% of them. Because the plume is not contained, mixing downstream of the painter dilutes the local concentration of VOCs by two or three orders of magnitude. Thus—within the capacity of conventional exposure-sampling methods to discriminate—concentrations measured in the painter's breathing zone are so large that a background concentration of overspray-derived contaminants in the exhaust will be indistinguishable from that of fresh air. Because the requirement for PPE is intrinsic to the materials used in the process, the painter remains adequately protected.

In the ideal, conceptual process sketched in Figure 1, a portion ($1/r$) of the air drawn through the particle filters by the exhaust blower e is exhausted directly through the carbon adsorber to the atmosphere. The reciprocal of this fraction, r , is defined as the *recirculation ratio*. The recirculating stream is the remaining $(1-1/r)$ fraction, which is drawn through the particle filters by the recirculation blower r . The recirculating stream is drawn back, together with a slightly smaller amount of conditioned fresh air than was exhausted, mixed, and pushed through the intake duct by the intake blower i in a continuous process. The push-pull interaction of the two blowers combines with limiting the volume of makeup air to keep all regions inside the ventilation system and work area at negative pressure relative to all surrounding areas.

Because aircraft are streamlined along the flight axis, alignment of the flight axis parallel or antiparallel to the ventilation stream provides the closest approximation to uniform airflow across the aircraft surfaces. Compared to a constant process producing a mean concentration c_0 in directly exhausted air, applying recirculation as diagrammed will raise³ the mean ambient concentration in the booth by an amount that approaches $c_0 r$ as the steady-state limit. LaPuma⁴⁻⁶ has expanded this idea into a computational model from which average concentrations of selected toxicants in air may be estimated for painting and a number of other maintenance operations in a space of specified dimensions at arbitrary recirculation ratios, as a tool to aid in facility design. Instantaneous concentrations will vary somewhat around this average, both within the enclosure and with time; however, a more-precise treatment of concentrations and motion in four dimensions would be prohibitively complex and would necessarily yield a probabilistic result rather than an exact value.

The consequential source of toxicants is airborne paint particles that do not deposit on the surface being painted (overspray). Under favorable conditions, motion in the air stream surrounding the painter brings toxicants into his breathing zone at concentrations two to three orders of magnitude larger than the recirculated background concentration, which seldom if ever attains the steady-state value because paint guns are rarely operated continuously. This is also far too complex a behavior to model⁶ precisely, but it should be clear that the movement of a fixed amount of air and the distribution of contaminants

freshly delivered into it will not be significantly affected by connecting the ductwork between the exhaust and intake plenums. Both intuition and the modeling results suggest a generalization that incorporating recirculation will not degrade the performance of a competent ventilation system. However, recirculation definitely will not ameliorate the problems⁷ of an inadequate ventilation system, and it should *never* be used in one.

Figure 1. Airflows in an Idealized Recirculating Ventilation System. To Promote Infiltration, Blower *i* Moves Less Air Than Blowers *r* and *e*.

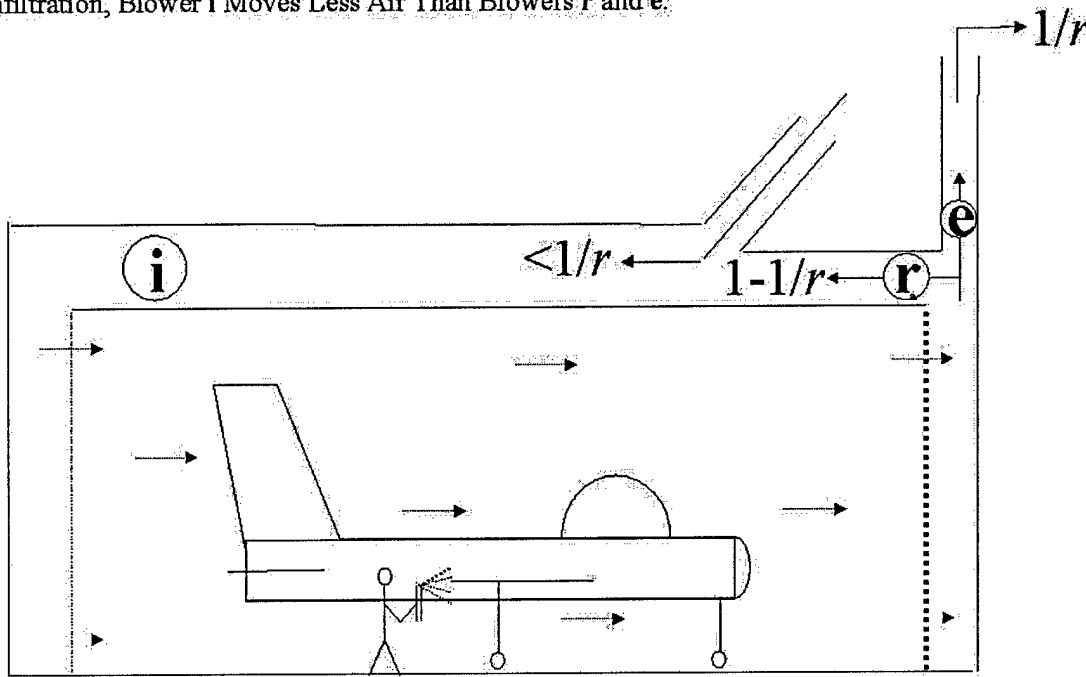

The engineering to incorporate recirculation is simple and adds only minimally to the complexity of maintaining the painting facility. Several benefits derive from recirculation, which decreases the net passage of air through the facility by a factor of r , while retaining the same air movement within the working space. *E.g.*, for 100 kcfm ventilation at 80% recirculation, the fraction exhausted = $0.20 = 1/5 = 1/r$, $r = 5$, and net air consumption by the facility decreases to 20 kcfm. Energy consumption by the HVAC unit decreases by the same 80%, and equipment and construction costs decrease by a smaller factor. An incidental benefit is that the net emission of particles is decreased slightly by repeated passage through the filters. And an option that may be opened is application of a VOC destruction technology, for which the cost is determined by the volume of air treated.

Decreased Ventilation Rate

General wisdom about painting in strong winds implies that the efficiency of deposition of paint droplets increases over some range of decreasing ventilation rates. Optimizing airflow for paint deposition would entail significant implications to cost management: decreased HVAC costs, decreased paint consumption, increased filter life, and decreased HazWaste generation. The ventilation rates specified in 29 CFR 1910.94 (c)(6)(i) and

1910.107 (b)(5) appear to be prudent, arbitrary values, and they also appear⁸ to be an unenforceable standard. In practice, permissible exposure limits (PELs, defined in 29 CFR 1910.1000) and lower explosive limits (LELs [29 CFR 1910.94 (c)(6)(ii)]) will serve as the criteria⁸ for enforcement actions. It is not unreasonable to speculate that the combination of lower particle “concentrations” and decreased local turbulence will afford the added benefit of decreasing the flux of toxicants to which the painter is exposed at flows still sufficient to clear overspray from the painting area (and breathing zone).

Many facilities casually adopt this ventilation option by exempting and continuing to operate booths and hangars that drift below the standards for air movement, as long as PEL and LEL measurements remain compliant. This practice epiphenomenally attains the intent of DoDD 5000.1; however, a systematic study of deposition and exposure is needed to develop a basis for designed engineering implementation of the technique as a means for cost management.

BUILDING 198, MOUNTAIN HOME AFB

Background

Mountain Home Air Force Base (MHAFB) is located in SW Idaho, in high desert terrain. Actual heating and cooling requirements to maintain facility temperatures of 65–78 °F during FY 1999 are presented in Table 1. The table shows that for a period of five months the average temperature remained near 30 °F.

Month	Heating		Cooling		Month	Heating		Cooling	
	99/00	30-yr	99/	30-yr		99/00	30-yr	99/	30-yr
Aug	17	62	303	301	Mar	737	714	0	2
Sep	118	194	34	126	Apr	355	488	0	20
Oct	378	456	0	24	May	154	290	20	74
Nov	1059	817	0	0	Jun	22	130	155	186
Dec	1085	1063	0	0	Jul	2	44	349	351
Jan	1034	1121	0	0	Aug	0	62	318	301
Feb	698	859	0	0					

Missions at MHAFB include simple and intermediate-level maintenance of two models of large aircraft, KC-135 tankers and B-1B bombers. Building 198 was erected during 1997–1998 to contain operations to maintain mechanical and electronic systems as well as coatings, and office and storage space are included as well. As a cost-containment measure MHAFB incorporated an 80% recirculating ventilation system in the design specifications. To limit the impact of the painting operations to its air permit the base also incorporated a bank of activated carbon filters, scaled to remove at least 90% of VOCs

from the exhaust. A destructive treatment system was considered, but the predicted emission rate of about 1 ton/year of VOC was too small for anything other than a retentive carbon adsorption system to be economical to install and operate. MHAFB's initial design specifications also included horizontal, tail-to-nose air movement, but this instruction was lost in the course of developing and approving designs.

Two views of the building are reproduced as Figures 2 and 3. Aircraft enter nose in from the right of Figure 2, through the set of suspended doors visible in Figure 3, which close to form a nominal seal. The workspace is approximately hexagonal, 180 feet long and 160 feet side-to-side. This allows approximately 10 feet of clearance between the walls and the ends and wingtips of the aircraft. As specified in Figure 1, half as much air is supplied fresh as is exhausted, creating a negative pressure gradient with respect to both the outside and the remainder of the building. Infiltration of air through imperfections in the enclosure ensures that airborne contaminants are confined to the interior of the work area and the ventilation and exhaust system.

Figure 2. West Face of Building 198, Mountain Home AFB.

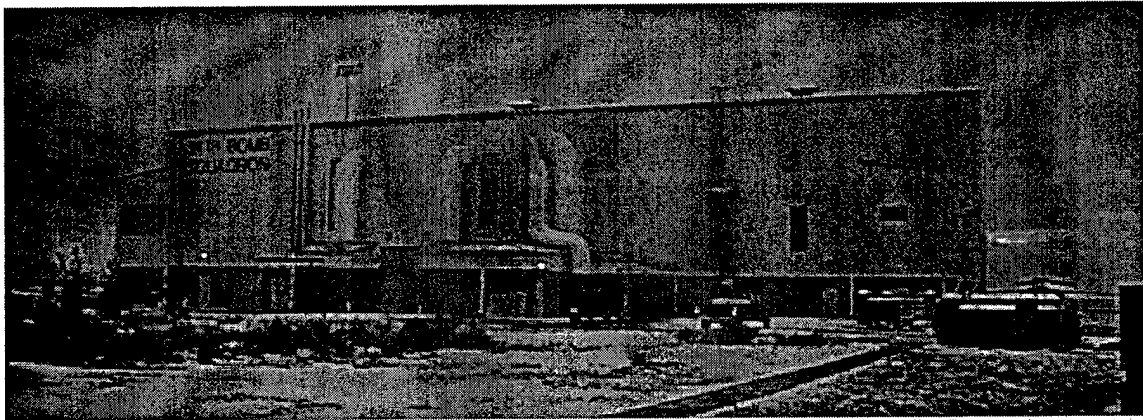
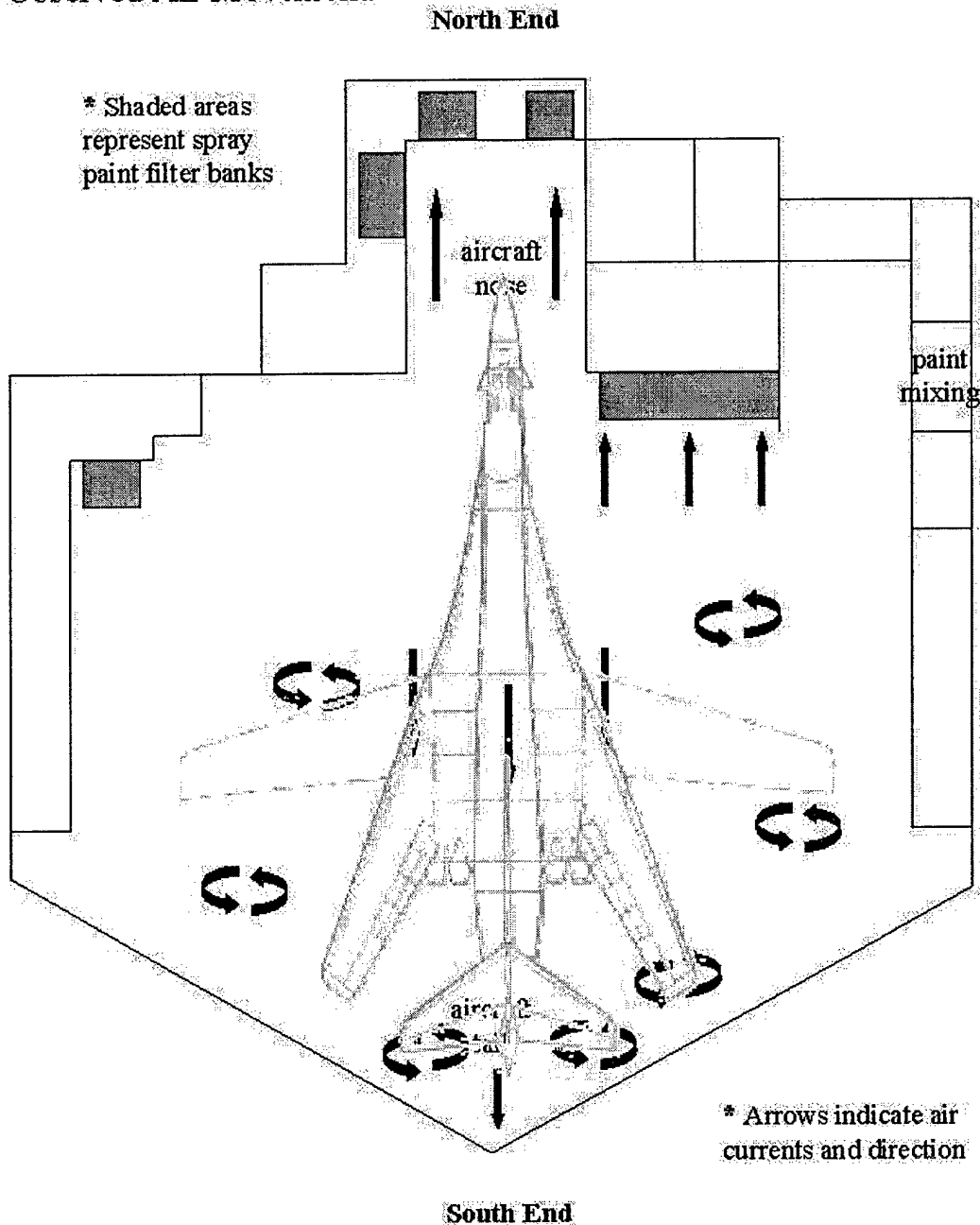

Figure 3. Front (South) Face of Building 198, Mountain Home AFB.



Figure 4. Top View of Painting Area, Building 198, Showing Observed Air Movement.



Necessary³ safety measures are incorporated. Concentrations of VOCs are continuously measured on both sides of the carbon system, and monitored in a partitioned control room. The measurements inside serve to ensure that operations—but not ventilation—will be interrupted if some catastrophe were to cause an excessive concentration. This includes the LEL in principle, but in practice the PELs are much lower and would trigger any emergency process shutdown. To limit the likelihood of spontaneous ignition⁹ of the carbon bed, a small amount of air movement is maintained through the carbon filters when the ventilation system is not operating.

As the hangar was delivered, four vents on the ceiling focused 210 kcfm of recirculated air onto the fuselage. A second set of vents delivered 50 kcfm of fresh (makeup) air onto the nose of the aircraft, between the main jet and the exhaust filters (which accept 260 kcfm). Figure 4 is a top view of the work area, showing airflow patterns that were visualized with a smoke generator in January 2000. Figure 5 illustrates the relative placement of ducts delivering recirculated and fresh air. The placement of the fresh air ducts both aggravates turbulence in the main air movement pattern and excludes most of the fresh air from the working area. The upper plot in Figure 6 catalogues variations in velocity (+ is forward) measured 28 March 2000 across the leading edge of a B-1B. Interviews with painting staff the same day revealed that application and drying characteristics changed drastically over short distances, and that extensive recoating to achieve visibly complete coverage consumed more paint than expected.

Figure 5. Airflows Inside Building 198. Separate Blowers Deliver Fresh (f), exhaust (e), and Recirculated (r) Air Through Independent Ducts. Opposing Flows Create Turbulence, Which Was Partially Tuned Out by Adjusting Louvers.

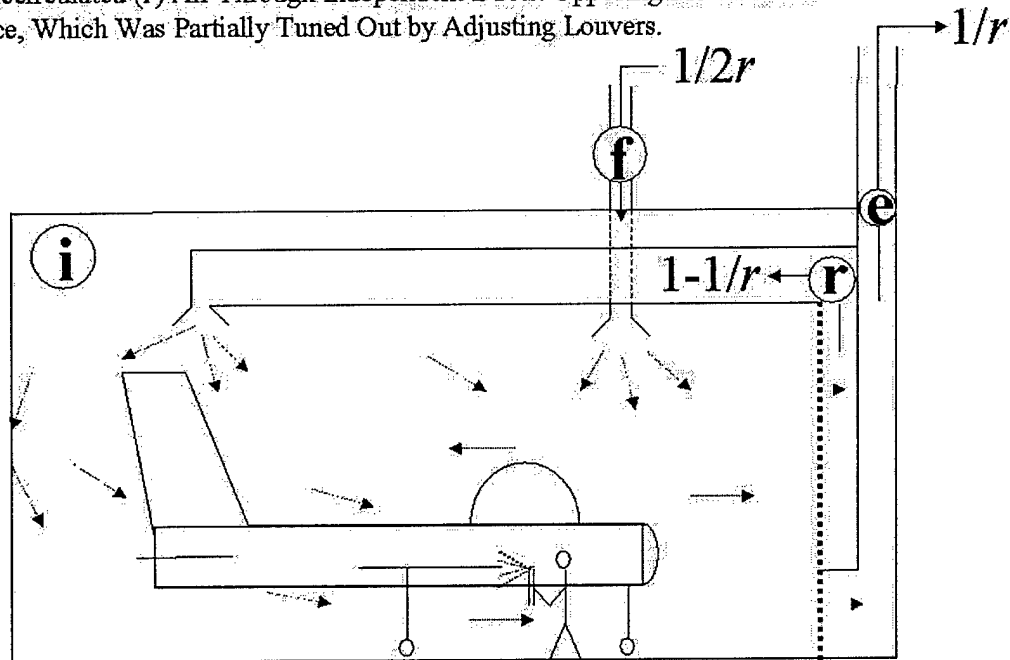

A recommendation that adjustments be made to the louver settings was implemented 23 June 2000, by personnel riding a cherry picker. Three iterations of adjustments and measurements resulted in a more-usable compromise, described by the lower plot in Figure 6. Air circulation approximates a cyclonic pattern around the center of the plane, so a job that faces upwind on one side of the plane faces downwind on the other. However, velocity gradients are much less drastic and only a few spots fall outside a range of 50–125 feet/minute of air movement. Air movement remains somewhat better above than below the wings and fuselage. However, the continuing presence of “dead” regions near the centers of eddies is an unsatisfactory condition—air movement is provided to clear overspray and vapor from both the job and personnel working in the

area. These do not clear effectively from regions of dead air, so improvements to date have decreased but not eliminated this fault, which we are still working to fix.

Figure 6. Air Movement at the Leading Edge of the Wings of a B-1B Aircraft in Building 198 Before (Upper) and After (Lower) Three Iterations of Adjustments to Orientation of Exit Ducts and Louvers.

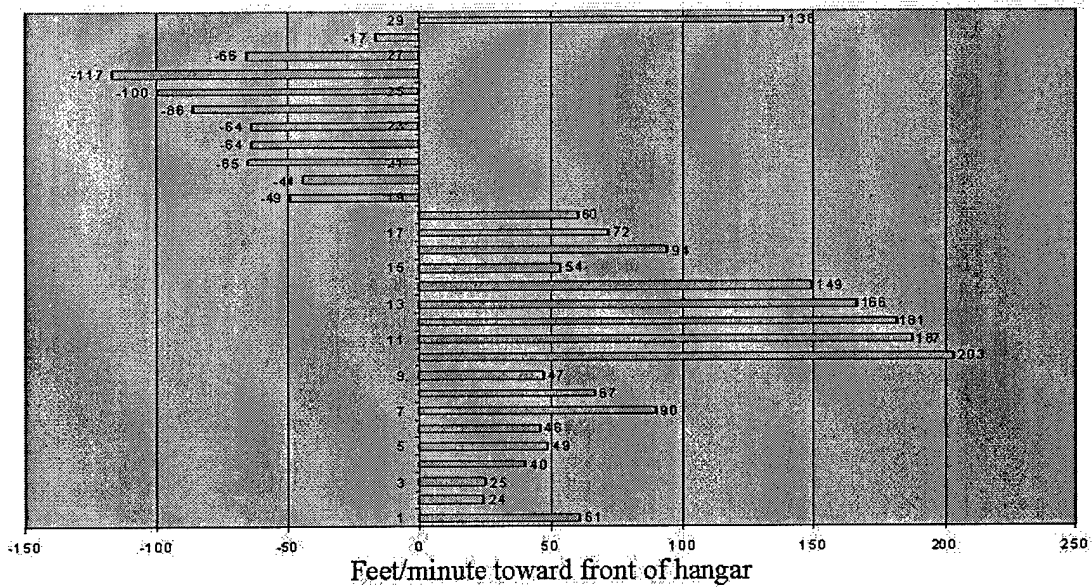
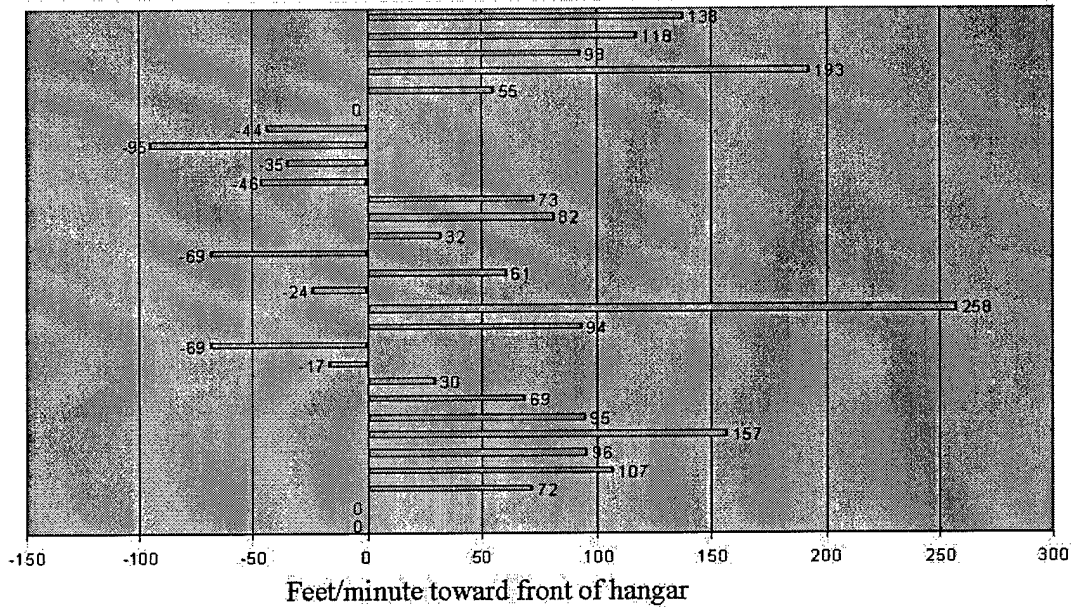

This process was conducted with an aircraft in place to accommodate the perturbation of airflow patterns caused by introducing an object into the stream, and measurements were taken across the leading edge of the wings because this is a region in which air movement is required. The same protocol—with the aircraft most-often repaired and painted in place—is recommended for all painting area surveys. Note also that air movement through filter faces is a necessary but not sufficient condition for adequate ventilation of a

painting workspace—air can channel around the outside the working volume or change direction before entering the filter face. In one painting insert within a large hangar at another base, air delivered from overhead ducts swept the ceiling and rear wall to the exhaust filters, moving no air in the work area.

A routine personnel and area monitoring survey was conducted 25–27 January 2000 in Building 198. The complete set of results listed in Table 2 is indistinguishable from typical survey results for a conventionally ventilated¹⁰ facility. None of 15 measurements of strontium chromate (SrCrO₄) and 18 measurements of hexamethylene diisocyanate (HDI) detected either substance. Detection limits for HDI are sufficiently low in these determinations that it can be stated positively that all 18 actual values are less than the permissible exposure limit (PEL). However, detection limits for many of the chromate samples were too high to permit a definitive conclusion about exposure levels. The respiratory protection factor of protective equipment supplied is 50, so the action level for chromate is 0.0125 mg/m³. Proper fitting and use of protective equipment are necessary to achieve full protection, exactly the same as in a conventional painting facility.

Date	Sample Type	Cr ⁺⁶ [mg/m ³]		HDI [mg/m ³]	
		PEL	Measured Concentrations	PEL	Measured Concs.
25 Jan 00	Pers	0.0005	<0.013, <0.018	0.034	<0.003, <0.018
	Area		<0.010, <0.010, <0.012, <0.013, <0.011		<0.002, <0.002,
26 Jan 00	Pers	0.0005	<0.0075	0.034	
	Area		<0.016, <0.016, <0.015, <0.016, <0.0090, <0.0075		<0.0003, <0.003, <0.0003
27 Jan 00	Pers	0.0005		0.034	<0.0008, <0.001
	Area		<0.0069		<0.0009, <0.003, <0.0008, <0.0003, <0.0004, <0.001, <0.001, <0.001, <0.001

DISCUSSION

Regulations

Although no direct measurements were made of organic vapors, clearance—as indicated by the data in Table 2—is so efficient that total concentrations of VOCs are certainly of the order of 100 ppm or less outside the immediate plume before the paint gun, consistent with measurements³ in smaller facilities. At regular intervals during operation, sensors in the ducts measure and record total VOC concentrations and compare them to threshold

values. PELs for abundant volatile constituents of these coatings are large enough that no assumption about rates of volatilization could contrive approaching an action level at the time those measurements were taken. Compliance with 29 CFR 1910.1000 necessarily implies compliance with 29 CFR 1910.94 (c)(6)(ii) because LEL>>PEL for all volatile organic solvents used in applying aircraft coatings.

As noted in the introduction, the background concentration of toxicants is deliberately increased by recirculation—which directly increases risk to personnel. However, the results in Table 2 and data from Hill AFB¹⁰ indicate that in a properly designed and maintained facility this should prompt no serious ethical concern. Air movement inside the workplace is not altered. Measured¹⁰ increments to exposure are less than the uncertainty of measurements that would be used to detect it. Gratuitous escalation of risk is clearly unethical but, in balancing acceptability of risk against cost savings, we should acknowledge that the PEL is defined as a threshold for safety.

Function

Although the airflow pattern is not the ideal—homogeneous and laminar—Building 198 adequately and safely serves the purposes for which it was built, and reconfiguring the ventilation system is not considered an urgent priority. The dominant consideration driving the use of recirculation was energy economy. Emission control was included to (and did) minimize the impact of the new facility on the base's air permit.

Month	Savings (MMBTU)			Savings (\$K)	Savings (CO ₂ , Tpy)
	Heating	Humidifying	Total*		
January	583	251	993	3803	78
February	467	192	785	3005	62
March	330	121	538	2056	42
April	210	65	327	1302	27
May	101	24	149	570	12
June	34	5	46	178	4
July	6	0	7	27	1
August	11	1	14	55	1
September	57	11	81	310	6
October	192	59	299	1144	23
November	421	168	701	2686	55
December	572	245	973	3725	76
Total	2986	1141	4913	18815	386

*Includes heating boiler manufacturer's rated efficiency factor of 0.84.

Table 3 is an estimate of the energy savings realized during a typical year (Table 1) of operation for 17 hours/week at a ventilation turnover rate of 52 kcfm. Because the

calculation is based on 30-year-average temperatures sorted into 5-degree bins for three shifts, and uses values for only the shifts worked, the estimates are expected to be accurate. Note that evaporation uses 30% of the space energy required, and that 16% of the energy actually consumed is lost to various inefficiencies.

No comparison to the cost of a conventional ventilation system was made in the development of Building 198, but construction estimates are typically 10–25% lower for recirculating hangars than for conventional facilities. Costs for added ductwork, blowers, and safety devices are generally much less than cost savings resulting from smaller HVAC equipment. Maintenance requirements and costs remain to be verified in practice for Building 198, but industrial facilities¹¹ have successfully used and maintained similar systems for decades and—especially in the current era of privatization—most common military industrial operations differ very little from their commercial counterparts.

CONCLUSIONS AND RECOMMENDATIONS

Personnel exposure measurements for chromate during application of primers and for isocyanates during application of topcoats demonstrated that 80% recirculating ventilation did not produce discriminably elevated health risks for properly protected personnel painting in that environment.

Engineering calculations show that significant avoidances of energy cost and consumption, and of greenhouse gas emissions were achieved by recirculating 80% of the exhaust air:

- \$20K not spent for
- 5 GBTU of fuel not consumed
- 325 tons of greenhouse gases not emitted as direct combustion products, and
- nearly a ton of VOC emissions that might otherwise have pushed MHAFFB from minor to major status under Title V.

Thus the cost–benefit trade of applying recirculation in Building 198 satisfies the intent of DoDD 5000.1—to control costs by managing risks.

Because Building 198 is unexceptional except for the mode of ventilation, favorable cost–benefit trades are expected to be available as a general condition, but several factors must be considered:

- Recirculation contributes nothing to VOC control—it is purely a cost-control device.

- Designs for new Air Force painting operations have historically relied heavily upon existing templates. The ventilation system in Building 198 has demonstrated the practicality and safety of recirculating painting exhausts; however, design faults cause air movement in the painting space not to streamline along the aircraft surfaces, and these elements should not be emulated.
- This demonstration applies only to large painting enclosures. In a 10-foot-by-10-foot booth organic vapors will experience only one-order-of-magnitude dilution from plume to exhaust. Recirculating 80% of that air will increase the average concentration at the painter by roughly half—expected to be easily detectable—and decrease the volume of air exhausted by a mere 5000 cfm. Considering local³ factors, the cost avoidance for conditioning this much air will likely (but not automatically) not be seen as justification for recirculation.
- Each installation is unique, and no best configuration can be defined for all facilities. *E.g.*, if attaining zero emission or extreme limitations on available power dominate design considerations, greater increases in exposure risk might be tolerated.
- The risk–benefit determination assumes a new facility and proper operation. Vigilant policing of both operating and maintenance procedures is necessary to maintain the level of risk subscribed to when the design was drawn.
- [In all painting enclosures] air movement should be measured at the surfaces of a typical work piece in place for painting, both for acceptance testing of a new system and for periodic reevaluations of air movement. Measurements of average airflow at the exhaust plane are not descriptive of the movement of air in the ventilation field.

ACKNOWLEDGEMENTS

The calculations reported in Tables 1 and 3 were performed by Mr. Gerald Doddington, HQ AFCESA/CESM, Tyndall AFB. A number of excellent photographs of the interior of Building 198 were provided by TSgt Terry Nelson, 366 WG/PA, MHAFB.

REFERENCES

1. *National Emission Standards for Hazardous Air Pollutants and Control Techniques Guideline Document for Source Categories: Aerospace Manufacturing and Rework Facilities*; 63 FR 59, pp 15005–15033, March 27, 1998.
2. Smith, C. U.S. Patent 4 926 746, 1991.

3. Hughes, S., Ayer, J., Sutay, R. *Demonstration of Split-Flow Ventilation and Recirculation in an Air Force Paint Spray Booth*, Armstrong Laboratory, Tyndall AFB, Florida 1993; AL/EQ-TR-1993-0002 (EPA/600/R-94/214a); p 8.
4. LaPuma, P.T. *Recirculating Industrial Air: The Impact on Air Compliance and Worker's Safety. Case Study: Hill Air Force Base C-130 Painting Operations*, Air Force Research Laboratory, Tyndall AFB, Florida 1998; AFRL-ML-TY-TR-1998-4524.
5. LaPuma, P.T., and Bolch, W.E. *Applied Occupational and Environmental Hygiene* 1999, 14, 682-690.
6. LaPuma, P.T. *Applied Occupational and Environmental Hygiene* 2001, 16, 1-12.
7. Carpenter, D.R., and Poitras, B.J. *Occupational Health Assessment, Building 2280, Tinker AFB OK*, AF Occupational and Environmental Health Laboratory, Brooks AFB, Texas 1990; AFOEHL Report 90-094CA001EDC.
8. Plummer, J.E. *OSHA Interpretation: The airflow rate required for a spray painting area*. http://www.osha-slc.gov/OshDoc/Interp_data/I19970408A.html
9. Zerbonia, R.A., Brockmann, C.M., Peterson, P.R., Housley, D. *Proceedings Air & Waste Management Association's 93rd Annual Conference and Exhibition* June 2000, Air & Waste Management Association, Pittsburgh, Pa. paper #256.
10. Belser, W.B., Griffie, S.M., Smith, M.H., Palmer, G.R., Wander, J.D. *Proceedings Air & Waste Management Association's 94th Annual Conference and Exhibition* June 2001, Air & Waste Management Association, Orlando, Fla. paper #711.
11. Norton, L.E., Bryan, R.J., Becvar, D.P. *Evaluation of a Paint Spray Booth Utilizing Air Recirculation* US EPA Industrial Environmental Research Laboratory, Cincinnati, Ohio 1984; EPA/600/2-84/143.

KEYWORDS

air pollution control, aircraft painting, compliance strategies, cost containment, life cycle cost, pollution prevention, recirculation, risk benefit, spray painting, ventilation, VOC