



US Army Corps
of Engineers®
Engineer Research and
Development Center

Condition Prediction Model and Component Interaction Fault Tree for Heat Distribution Systems

Charles P. Marsh, Brian A. Temple, and Angela Kim

July 2001

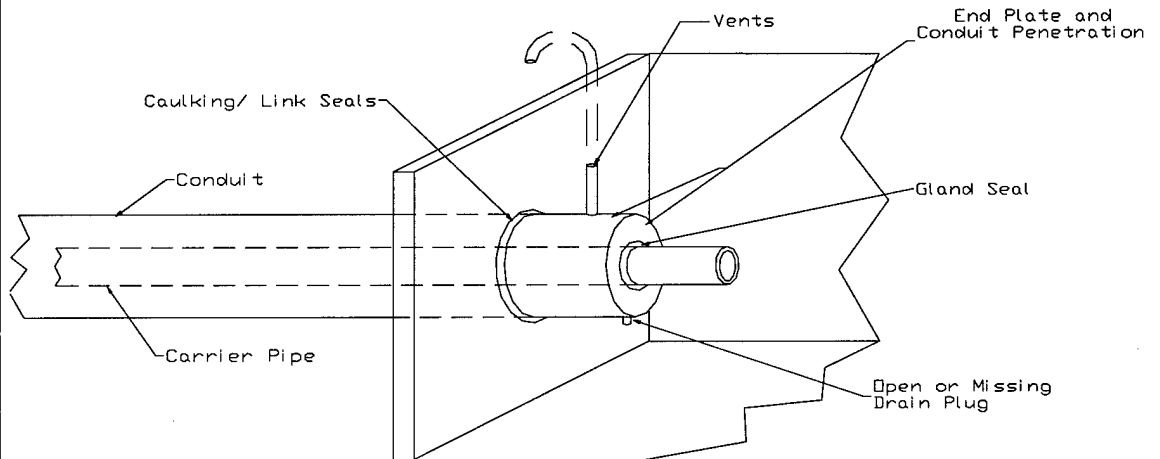

20010807 052

Foreword

This study was conducted for the Directorate of Military Programs, Headquarters, U.S. Army Corps of Engineers under Project 4A162784AT41, "Military Facilities Engineering Technology"; Work Unit CG9, "Smart Water Treatment." The technical monitor was Dale Otteness, CECW-ET.

The work was performed by the Materials and Structures Branch (CF-M) of the Facilities Division (CF), Construction Engineering Research Laboratory (CERL). The CERL Principal Investigator was Dr. Charles P. Marsh. The technical editor was Gordon L. Cohen, Information Technology Laboratory – Champaign. Martin J. Savoie is Chief, CEERD-CF-M, and L. Michael Golish is Chief, CEERD-CF. The Acting Technical Director of the Facility Acquisition and Revitalization business area is Dr. Paul A. Howdyshell. The Acting Director of CERL is Dr. Alan W. Moore.

CERL is an element of the Engineer Research and Development Center (ERDC), U.S. Army Corps of Engineers. The Commander and Executive Director of ERDC is COL John W. Morris III, EN, and the Director is Dr. James R. Houston.

DISCLAIMER

The contents of this report are not to be used for advertising, publication, or promotional purposes. Citation of trade names does not constitute an official endorsement or approval of the use of such commercial products. All product names and trademarks cited are the property of their respective owners.

The findings of this report are not to be construed as an official Department of the Army position unless so designated by other authorized documents.

DESTROY THIS REPORT WHEN IT IS NO LONGER NEEDED. DO NOT RETURN IT TO THE ORIGINATOR.

Contents

Foreword	2
List of Figures	4
1 Introduction	5
Background	5
Objectives.....	6
Approach	6
Mode of Technology Transfer	7
2 Fault and Condition Index Trees	8
HDS Components.....	8
Leak-Related “Chain Reactions”	9
The Applicability of Fault Trees.....	10
Explanation of the Condition Index Tree	14
<i>Manhole Components (L3P1)</i>	15
<i>Above-Ground Components (L3P2)</i>	16
<i>Shallow Trench Components (L3P3)</i>	16
<i>Direct Buried Pipe Components (L3P4)</i>	17
<i>Above-Ground Node (L3P5)</i>	18
3 Condition Index Evaluation	19
4 Conclusion	21
Appendix A: Fault Tree	22
Appendix B: CI Tree	61
Appendix C: Individual Component Graphs	75
Appendix D: Pipe Corrosion Equations	106
CERL Distribution	108
Report Documentation Page	109

List of Figures

Figures

1	Direct buried pipe segment and node.....	8
2	Failure pathway from DB pipe weld failure to heat convection losses.	11
3	Failure pathway from DB pipe weld failure to heat conduction losses.	12
4	Failure pathway for DB pipe weld failure with gland seal failure.....	13
5	Symbols used in the Condition Index tree.	14

1 Introduction

Background

Managers of heat distribution systems (HDSs) have in the past maintained their systems simply by identifying components needing repair and fixing them as necessary. If any preventive maintenance was applied, it generally was motivated by operator experience rather than established procedure. Manufacturer-recommended maintenance schedules have not always been reliable guides for maintaining individual components because manufacturers by definition are not highly motivated to document potential deficiencies in their own products. In other circumstances, where accelerated degradation of a component is caused not by its own deficiencies but by the incorrect operation of a related component, the successful tracking and repair of the problem often requires the long-term attention of a knowledgeable operator.

With the development of Engineered Management Systems (EMSs) by the Construction Engineering Research Laboratory (CERL), Army utility managers gained access to a set of repeatable inspection-based tools to help optimize system operation and prioritize maintenance requirements. In an EMS designed for HDSs, however, tracking the condition of individual components is not sufficient to realistically represent system condition. The components of an HDS are so closely interrelated that the failure of one component frequently degrades or overstresses the entire system. For example:

- If a steam trap fails to remove condensate from the lines, the resulting water hammer can affect the pipes some distance away from the bad steam trap.
- If insulation around carrier pipes degrades, the boiler must work harder than intended to produce enough steam to meet the heating load.
- If an expansion slip joint in a piping network seizes, damaging mechanical stresses may be transferred to segments or joints hundreds of feet away.

Effects such as these can significantly raise system life-cycle costs and reduce performance below specifications. In extreme cases the result could be catastrophic system failure. Therefore, it is essential that an EMS for heat distribution

systems be able to identify, track, and account for such destructive interactions as well as the more obvious component condition issues.

Objectives

The objective of this work was to develop a practical method for predicting the future condition of heat distribution systems.

Approach

Due to considerations stated under "Background," this project included engineering studies of the interactions of the various components that make up the three main types of HDS: *above ground*, *shallow trench*, and *direct buried*.

First, component interactions were analyzed and all possible failure pathways were identified. A comprehensive fault tree was developed for the three main types of HDS (Appendix A). This approach was then adapted to the segment-node and condition index analysis approach (Appendix B) inherent EMSs. In addition, a comprehensive but initial set of component degradation/failure curves were developed. Given the myriad variables, variations, and interactions involved, the development of definitive component degradation and/or reliability curves through physical testing was beyond the scope of this project. However, through the widespread implementation of the HEATER EMS, these initial component failure curves can be refined and collectively improved with data from the field.

The intended use of these results is to assign a condition index (CI) to each component involved with each segment or node. The best values are obtained through direct observation or testing, but if that is not feasible, a default CI value based on age can be assigned from the degradation curves. These values (whether observed or assigned) are then combined and applied to the appropriate fault tree to determine an overall CI for each segment or node. Future condition can be projected by using time as a parameter with which to determine the associated component CI value. If an actual inspection-based component CI value does not match one predicted by the applicable degradation curve, then for future predictive purposes an "apparent age" should be assigned and tracked so the values coincide. As the degradation curves are refined with new data, the true and apparent ages should on average increasingly coincide.

Mode of Technology Transfer

The results of this work are intended to be incorporated into the HEATER EMS software program currently under development by CERL.

2 Fault and Condition Index Trees

HDS Components

Heat distribution systems can be divided into two sets of components: the segment and the node. A *segment* comprises distribution pipes and related components (valves, expansion provisions, joints, etc.) that carry the steam* to the building load. A *node* is an intersection point that connects segments to one another or to the boiler. Nodes may comprise valves for controlling flow, steam traps, expansion provisions, sump pumps, and auxiliary tanks. The pipes from the segments enter the nodes through conduit penetrations. An example of a node-segment combination for a direct buried (DB) pipe system and its node is shown in Figure 1. The illustrated node includes containment wall, conduit penetration, and gland seal. The conduit penetration comprises a drain plug and an air vent pipe. Other common components of nodes (valves, steam trap, man-hole cover, and sump pump, for example) are omitted for visual clarity. The illustrated DB pipe segment comprises a carrier pipe, conduit, insulation, and an annulus between the carrier pipe and conduit.

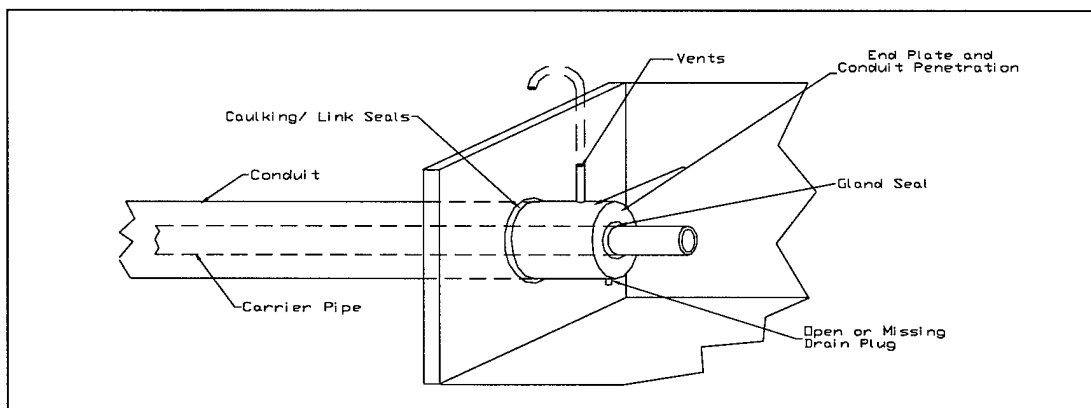

Figure 1. Direct buried pipe segment and node.

* Heat distribution systems may convey low-temperature hot water, high-temperature hot water, or steam. For purposes of brevity, the word "steam" in this report refers generically to the aqueous heat-conveying medium contained in an HDS. More specific terminology is used only where required for technical accuracy.

Leak-Related "Chain Reactions"

An effectively operating HDS keeps steam inside the system and environmental water outside. Not all degradation mechanisms involve "water where it shouldn't be," but many do. If hot water escapes from the system it can damage components through its heat and corrosive properties; infiltration of rain or groundwater also can damage components and degrade overall system performance.

Water can infiltrate an operating HDS through segments, nodes, or both. The example given here addresses infiltration through a node. Water can infiltrate a node through several paths — from the outside through a failed seal, a cracked containment wall, or directly through a manhole cover, for example. On the other hand, leakage from a valve, carrier pipe, or conduit can produce a hot water buildup in the node. A failed gland seal or a hole in the conduit penetration can provide a pathway for leakage to migrate between the segment and the node. Likewise, an air vent or an open drain plug on the conduit penetration will also provide leakage pathways between segments and nodes.

When water finds its way into a node, the interconnection of system components can support a "chain reaction" that ultimately leads to a complete system failure. If a sump pump fails, for example, unwanted water can accumulate in the node and lead to accelerated corrosion of other components such as a steam trap or valve. In other words, a component failure at one location can cause the degradation and failure of another component, as when a corroding valve from the previous example begins to leak on its own. Not surprisingly, then, leakage inside a node can lead to leakage in a connected segment. When this happens over time, new corrosion-related leakage pathways from the node to the pipe segment allow moisture to migrate into the pipe segment annulus. In turn, this moisture in the annulus accelerates corrosion of the conduit, which can then provide pathways for water to infiltrate the pipe segment from the ground. Consequently, the increased fluid presence in the pipe segment further accelerates the degradation of the carrier pipe in the pipe segment.

This type of chain reaction occurs not overnight but over several years. Component failures compound the effects of other failures systemically, greatly reducing the service life of HDS components while increasing both repair costs and utility downtime. In the sequence of events described above, the condition of a single sump pump appears to have a disproportionate impact on the condition of the entire system. Immediate repair of the sump pump would have prevented all related subsequent problems, avoiding (1) strenuous repair efforts by the system

manager, (2) large unbudgeted costs for the system owner, and (3) inconvenience and discomfort for the system user.

Without considering such interactions among components, an inexperienced system manager might incorrectly conclude that the replacement of an inexpensive sump pump is of lower priority than repairing leakage of an in-line valve. Therefore, a decision-support tool engineered to account for such interactions would be of great value to system managers, owners, and end users.

The Applicability of Fault Trees

A fault tree is a kind of flowchart that illustrates component relationships and failure chain reactions. Fault trees have been used for nuclear power plants and other mechanical systems to clarify complex causal chains and their effects. Figures 2, 3, and Figure 4 illustrate a fault tree for a DB node-segment such as the one described in the previous section. Each diagram shows possible failure pathways and their consequences.

A fault tree structure can be modified to represent component effects on other components. In this way, the condition of an entire system may be determined from the condition of its individual components. A quantitative value assigned to a system or its components is called a *condition index* (CI). In EMS terminology, the CI is a numerical value from 100 – 0 (representing perfect condition through complete failure, respectively) that reflects the condition of whatever it is applied to. The EMS defines a critical CI value that indicates component failure. This critical value varies according to the importance and purpose of each component.

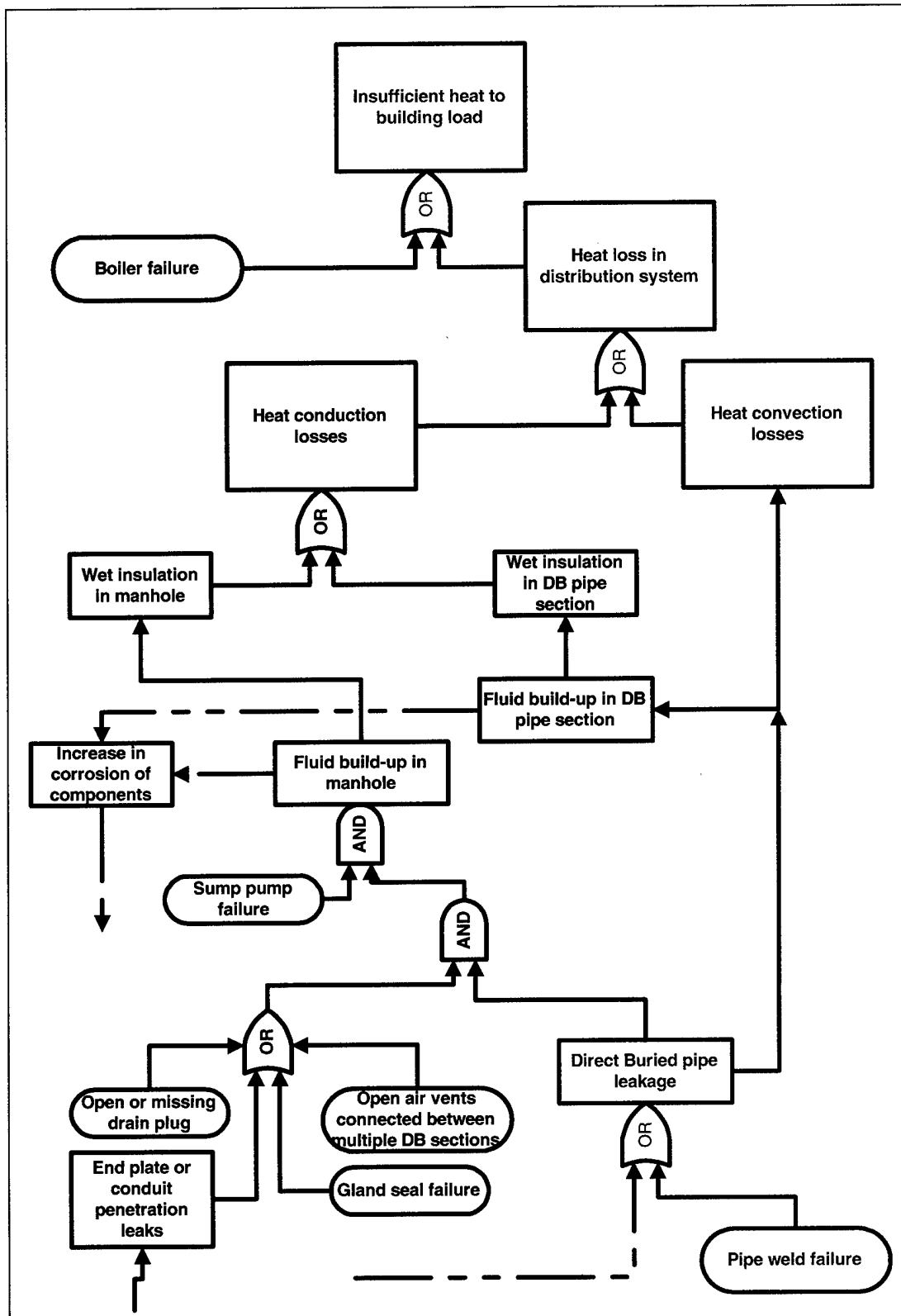

Figure 2. Failure pathway from DB pipe weld failure to heat convection losses.

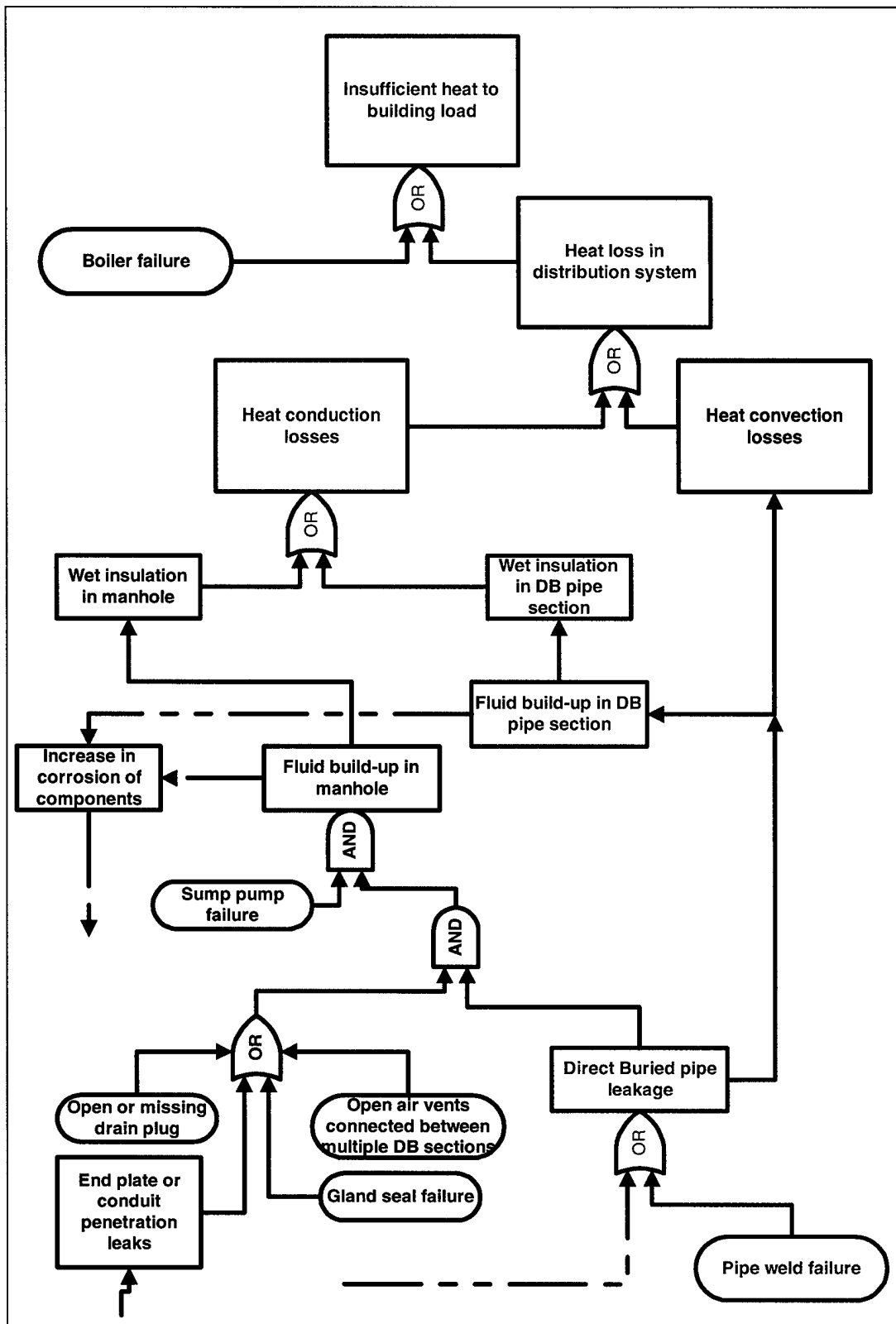

Figure 3. Failure pathway from DB pipe weld failure to heat conduction losses.

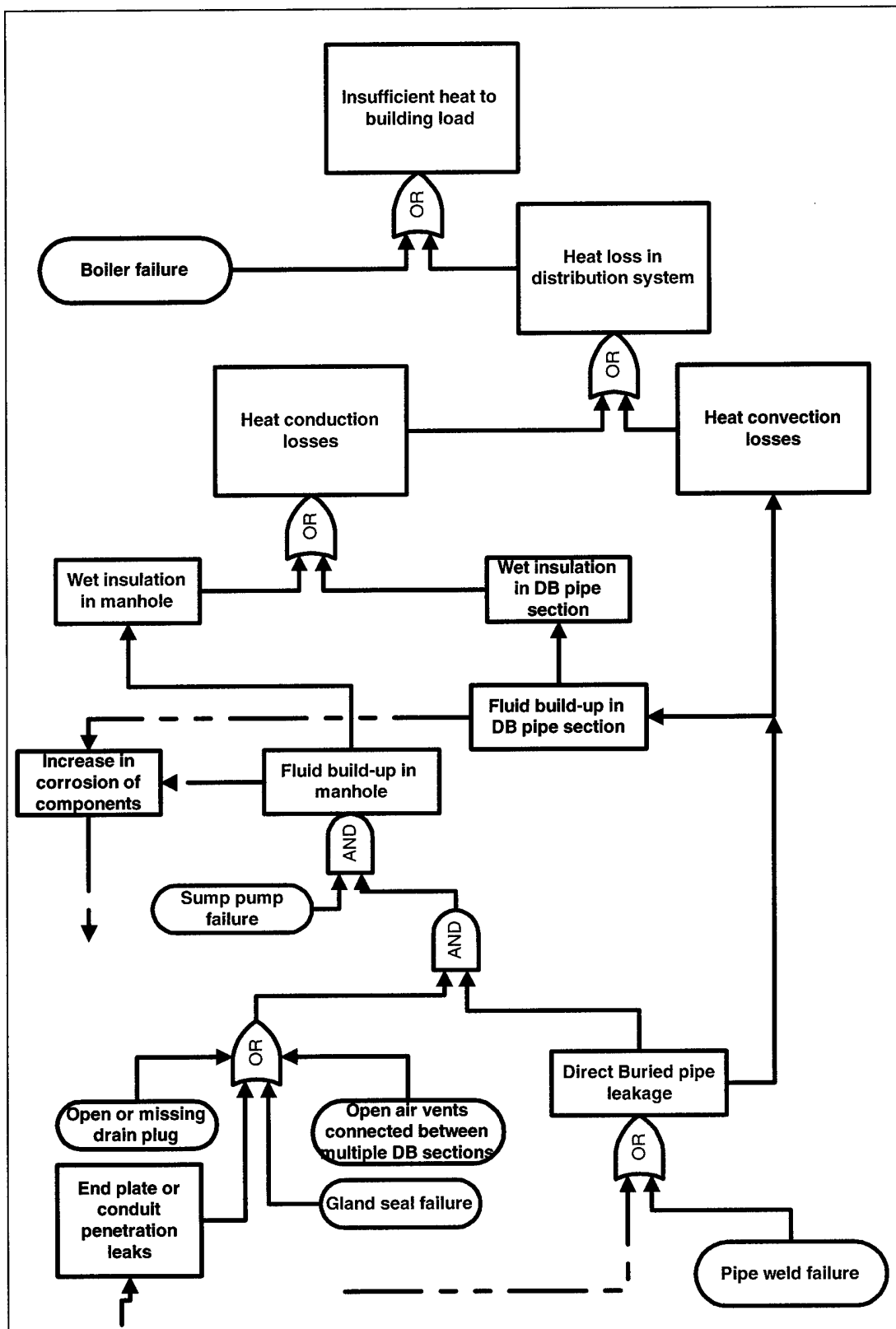

Figure 4. Failure pathway for DB pipe weld failure with gland seal failure.

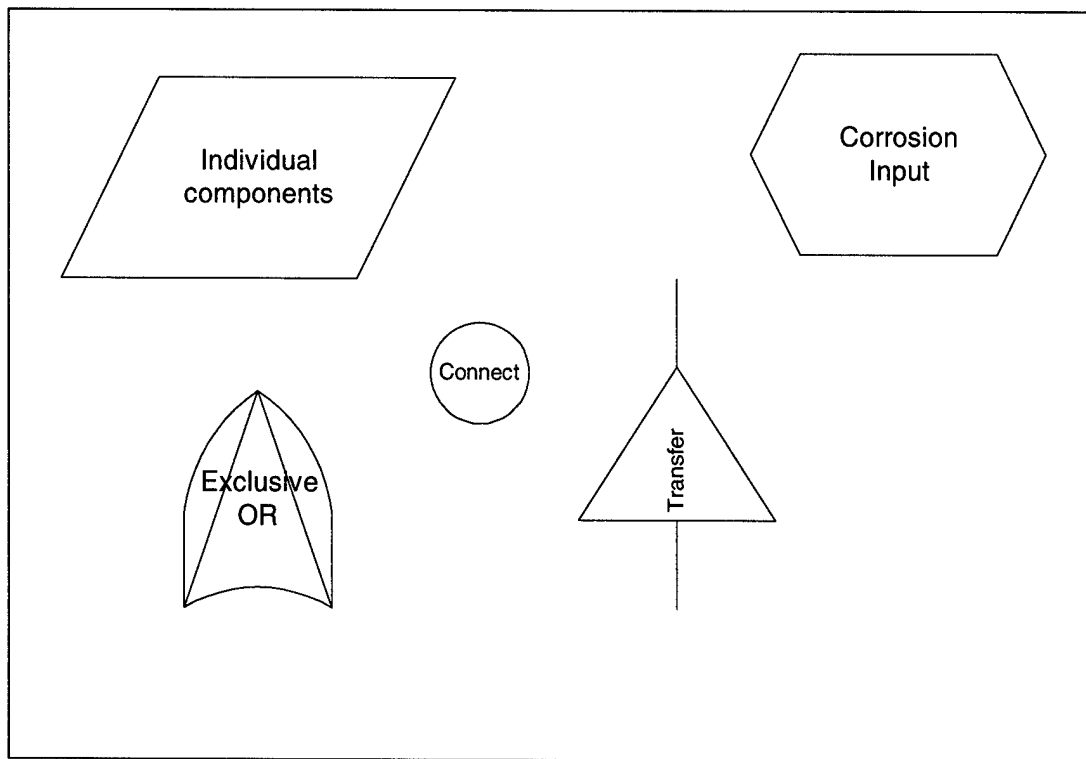

Figure 5. Symbols used in the Condition Index tree.

Explanation of the Condition Index Tree

In the context of an EMS, a CI tree (Appendix B) is a fault tree designed to relate the condition of individual components to the condition of the entire system. The symbols used in the CI tree are shown in Figure 5. Note that the Connect and Transfer symbols are common both to the CI tree and the system fault tree.

Parallelograms represent the individual components or groups of components, and contain the corresponding CI value. The CI values feed into the exclusive OR (ex-or) gates, where the numerical values are averaged to calculate the component CI value. Note that the gland seals, end plates, and conduit penetrations have component labels both in the manhole section and the DB pipe section. The colors and fills for the symbols representing multiple-entry components are kept the same in different sections of the system to assist with identification. The ex-or gate symbols represent the numerical evaluation of the condition indices of the input components for the system of those components. The ex-or gates also organize the structure of the CI tree. The importance of the component is weighted according to how high it is in the tree. For example, carrier pipes input into the tree multiple times to reflect the effects of the pipe on other components and establish the significance of the component's condition on the entire system. The transfer symbols simply connect the CI results from different pages. Consis-

tent colors and fills are used to make the transfer process clear. The hexagon shapes are the corrosion inputs for the corresponding components from empirical equations used in the Micro GPIPER EMS (Guglomo et al. 1992^{*}) and other programs that evaluate the effects of corrosion.

In the condition index (CI) tree, the system is divided into nodes and segments. The node conditions are given by the manhole components (CI tree, Appendix B, Figure B-2, L3P1 input) and the above-ground node components (Figure B-11, L3P5 input). The segments are given by the above-ground components (Figure B-4, L3P2 input), the shallow trench components (Figure B-6, L3P3 input), and DB components (Figure B-8, L3P4 input). Each section is identified by color. Components that interact directly with other components, such as manhole end plates, are kept in their corresponding section color but enter the tree in multiple locations.

Data for all five possible node and segment inputs feed into the final CI for the heat distribution system. All inputs are weighed equally and averaged to arrive at an overall system CI. If one or more inputs do not apply then they are ignored and the weighting of the applicable ones is adjusted accordingly.

The best way to describe a section is to start at the lowest part of the tree and work upward.

Manhole Components (L3P1)

The condition of internal components that can leak into the manhole are given on page L3P1A (Figure B-3). The smaller, less-important components that leak (valves and steam traps, for example) are evaluated at ex-or gate 3MH8 (Figure B-3). This result inputs with the CI of the pipes in the manhole to give a CI for the system at 3MH7 (Figure B-3), and this is transferred to page L3P1 (Figure B-2) by the red transfer symbol outlined in purple. The pipes input higher into the tree since they often leak more water and have a greater effect on the system than the valve and steam trap examples. The CI of the pipe is determined from the condition of the pipe supports and anchors, the amount of pipe corrosion, and data from the inspection form or, lacking that, the default graph. The pipe sup-

^{*} Guglomo, R.C., Vicki L. Van Blaricum, C.D. Page, and Ashok Kumar, *Micro GPIPER Implementation Program*, Technical Report FM-92/04/ADA256755 (CERL, July 1992).

port CI contributes to pipe condition since bad supports or anchors can allow excessive movement or strain that leads to pipe failure. CI values from inspection can be used to override the effects given by CI inputs from the corrosion CI and support CI values.

The CI of the possible internal leakage components inputs into the CI tree on page L3P1 at three locations. The lowest input addresses the buildup of fluid in the manhole due to internal leaks; the next higher input addresses the effects of internal leakage onto the insulation; the highest input addresses the effects of internal leakage on the condition of the entire manhole.

On the bottom of CI tree page L3P1 the averaged CI for external leakage is given at the output of ex-or gate 3MH6 (Figure B-2). This result is weighted with the internal component leakage at gate 3MH5 to give the CI for all sources of water buildup in the manhole. This input is in turn evaluated with the condition of the sump pump and the leakage-flooding alarm system at gate 3MH4 to give a CI value for the manhole's capability to eliminate water buildup. This result then inputs into the condition evaluation of the insulation at gate 3MH2 and the final condition of the system at gate 3MH1. Insulation condition is determined from the amount of internal and external water buildup at gate 3MH2 and the CI value from the inspection data or default graph. Final condition is then evaluated at gate 3MH1 from the state of internal leakage, insulation condition, and the manhole's capability to prevent water buildup.

Above-Ground Components (L3P2)

Leakage from internal components is given on CI tree page L3P2A (Figure B-5). The structure is similar to the manhole section except there are no steam trap or auxiliary components for leakage. The transfer symbol for internal leakage is yellow outlined in blue. It transfers to page L3P2 (Figure B-4) and inputs at the condition evaluation for the insulation (3AG2) and the entire above ground system (3AG1). Condition of the insulation is effected by internal leakage and the condition of the external jacket cover for external leakage onto the insulation. Final system condition is given by the insulation condition and internal leakage status.

Shallow Trench Components (L3P3)

Leakage from internal sources within a shallow trench segment is indicated by the final output of L3P3A (Figure B-7). The structure of page L3P3A is similar to page L3P1A for manholes except for the steam trap leakage factor, and pipe

condition is also affected by roller and slide components in addition to supports and anchors. The transfer of the internal leakage CI is green outlined in red and transfers to page L3P3 (Figure B-8). As in the manhole section the internal leakage transfer inputs into three ex-or gates. The lowest gate, 3ST4, evaluates the CI for water buildup in the shallow trench (ST). Inputs for this are trench wall or joint leakage; trench seal, caulking, or cover leakage; and non-local internal water leakage. This result inputs to the final ST system CI evaluation at gate 3ST1 and gate 3ST3, which evaluate the external leakage onto shallow trench pipe insulation. The output of gate 3ST3 (external leakage onto insulation) and the internal pipe leakage are evaluated at gate 3ST2 along with the insulation CI to provide a value that inputs into the final system CI at 3ST1. The final inputs for the ST system at gate 3ST1 are the internal leakage CI, the insulation CI, and the water buildup CI.

Direct Buried Pipe Components (L3P4)

This system is more complex than the previous two segments. It includes two feedback loops that require two evaluations of different CI values. The method for moving through the CI tree is as follows:

Starting on page L3P4B (Figure B-10), evaluate the inputs for gate 3DB7 to determine the CI for external leakage into the system. Note that the values for the gland seals and other subcomponents come from the corresponding manhole section components, as identified by color.

Next evaluate the CI for the corrosion condition of the conduit pipe (Figure B-14) by evaluating the inputs into gate 3DB6. Then evaluate the CI for leakage into the DB pipe system by evaluating the inputs for gate 3DB5. For the initial loop through the tree, the CI for transfer L3P4C (purple with green outline) is zero and is not weighed into the 3DB5 gate for the CI output. The output of gate 3DB5 gives the condition of the conduit, and this in turn inputs through the L3P4D transfer (yellow with green outline) to page L3P4A. This transfer inputs into the 3DB4 (Figure B-9) gate, which evaluates the DB carrier pipe condition. Factors that influence DB carrier pipe condition are the condition of pipe supports and anchors, the amount of internal and external corrosion, and the amount of external water leakage past the conduit given by transfer L3P4D.

The next step is to evaluate the CI for internal water leakage via gate 3DB3 (Figure B-9). Inputs are carrier pipe condition and the CI of any expansion joints. The CI for internal component leakage is then fed back through the tree via transfer L3P4C, and this transfer reflects the increased degradation of the

conduit by internal water buildup in the annulus. The L3P4C transfer is then inputted into gate 3DB5, along with the previous inputs from gates 3DB6 and 3DB7, to reevaluate the CI of the conduit. The conduit CI reflects the external leakage probability of the system and is inputted through both transfers (L3P4B and L3P4D) into page L3P4A and L3P4, respectively. As before transfer L3P4D is inputted into gate 3DB4 along with the previous CI values for pipe corrosion and pipe supports and anchors to provide the pipe condition of the system. As before, this result is evaluated at gate 3DB3 with the previous CI input for the expansion provisions to give the internal leakage CI for the system. This CI value is now transferred only through transfer L34PA to page L3P4. On page L3P4 (Figure B-8) the transfers L3P4A and L3P4B give the CI for internal and external water leakage respectively. These values are inputs for the insulation condition (gate 3DB2) and the final condition of the DB system (gate 3DB1).

Above-Ground Node (L3P5)

This portion of the CI tree exists to cover the possibility of an above-ground valve station as a node instead of a manhole for above-ground systems. The CI for internal leakage is given by the resulting CI value determined at the top of page 3AGN3 (Figure B-12). For this section the CIs of the valves, auxiliary components, and pipes are affected by the condition of supports, anchors, and the elevated structure supports containing the components. This CI is evaluated by gate 3AGN6 and inputs into valve condition, auxiliary components condition, and gate 3AGN5. The CI for leakage of internal components other than pipes is determined by gate 3AGN4. The CI for the pipes is evaluated at gate 3AGN5, and is inputted by gate 3AGN6 and the corrosion CI. The final internal leakage CI is compiled by gate 3AGN3. Inputs for this gate are the internal leakage CI of non-pipe components and pipe CI. The output of gate 3AGN3 goes to transfer L3P5A, which is purple outlined in light blue. L3P5A inputs on page L3P5 (Figure B-11) to the insulation condition evaluation (gate 3AGN2) and the final system evaluation at gate 3AGN1. As before, the insulation CI is evaluated at gate 3AGN2 by the internal leakage CI and the external jacket cover CI, the latter of which reflects the probability for external leakage onto the insulation. The insulation CI and the internal leakage CI give the above-ground node CI at gate 3AGN1.

3 Condition Index Evaluation

CI values for components are determined by inspections, site-specific and historic graphs of the system's condition over time, or default degradation curves (Appendix C) that predict the condition of the component over time. The components and their age are stored in a separate part of the HEATER program database, and these values are referenced to find the time value for the graphs. The best CI values available for individual components are inserted into the CI tree at locations represented by parallelograms. The individual input values are then averaged at nodes such as 3MH8 or 3STZ to arrive at an overall individual segment or node CI. This process is then repeated for all segments and nodes being evaluated. These values, in turn, can be averaged to arrive at an overall, system-wide CI.

The relative importance of an individual component is accounted for in part by its place in the CI tree hierarchy. CI values obtained from inspection are entered into the database and used as a starting value for the individual component historic graphs. The resulting graphs serve as an indicator and record of the degradation rate over time and can be used to project component failure. These graphs are semi-quantitative representations of the component condition over the life of the system. Any replacement of a component should correspond with either the creation of a new component or a recalibration of component age. Each plot has critical CI values that represent a failure of the component due to standard degradation. A second plot is included on the graph to represent accelerated system degradation owing to component damage or failure. The future condition of components can be projected by identifying CI values at the desired future time using the corresponding CI graphs and evaluating the CIs as shown in the CI tree structure. Components listed in the tree that do not exist in the system described are given a zero CI value and are not weighed into the averaging process for the system. Corrosion condition indices are determined using empirical pipe corrosion equations developed for the SCALER program (see Appendix D). Values of the internal water condition are entered into the equations along with the original wall thickness of the pipes. The thickness of the corroded wall, given as a percentage of original wall thickness, comprises the pipe corrosion CI.

The degradation of an entire node-segment system can be understood by following the individual component degradation through the interrelationships established by the CI tree. System condition over time can be projected using the CI values based on inspection data and/or data from the default degradation curves. This projection provides HDS managers a guideline for estimating future M&R expenditures and a basis for prioritizing repairs.

It is noted that more exact representations of an individual component's condition over time, as they are developed, can be incorporated into the CI tree. As a result of increasing precision at the component level, the accuracy of overall system condition projections also should be expected to increase.

4 Conclusion

The components of heat distribution systems have complex systemic interdependencies, and the failure of any given component in a system can distress other components in ways that are not immediately obvious. The compounding effects of component degradation challenge the performance of an HDS to a far greater extent than it does in many other engineered facility systems. EMSs provide a logical, largely objective set of criteria for inspecting and documenting the condition of a system, but special considerations must apply to an EMS developed for HDSs. Specifically, a HEATER EMS must account for the unique interdependencies of HDS components.

The fault tree paradigm has proven to be useful for tracking the condition of complex mechanical systems such as nuclear power generators. A similar approach to condition tracking and projection can be incorporated into a HEATER EMS by (1) flowcharting component condition interdependencies into fault trees and (2) developing methods and algorithms that compile component condition data into an overall system condition index.

The product of the current study is a CI tree that accounts for all major interdependencies and weights various components according to their level of impact on overall system condition. This CI tree can be incorporated into the HEATER EMS to provide a more realistic method of projecting system condition than would be available through tracking only the conditions of independent components. The general structure of the CI tree allows the user to easily vary the input parameters for one or more individual component conditions and then determine the interconnected and system-wide effects. With experience, the addition of more accurate component profiles is also possible.

Because the interrelationships among HDS components are maintained over time by the structure of the CI tree and the fault tree, the effects of various component repair or replacement can be factored into overall system condition. This capability makes it less complicated to revise system-condition projections for use in scenario-based planning and budgeting.

Appendix A: Fault Tree

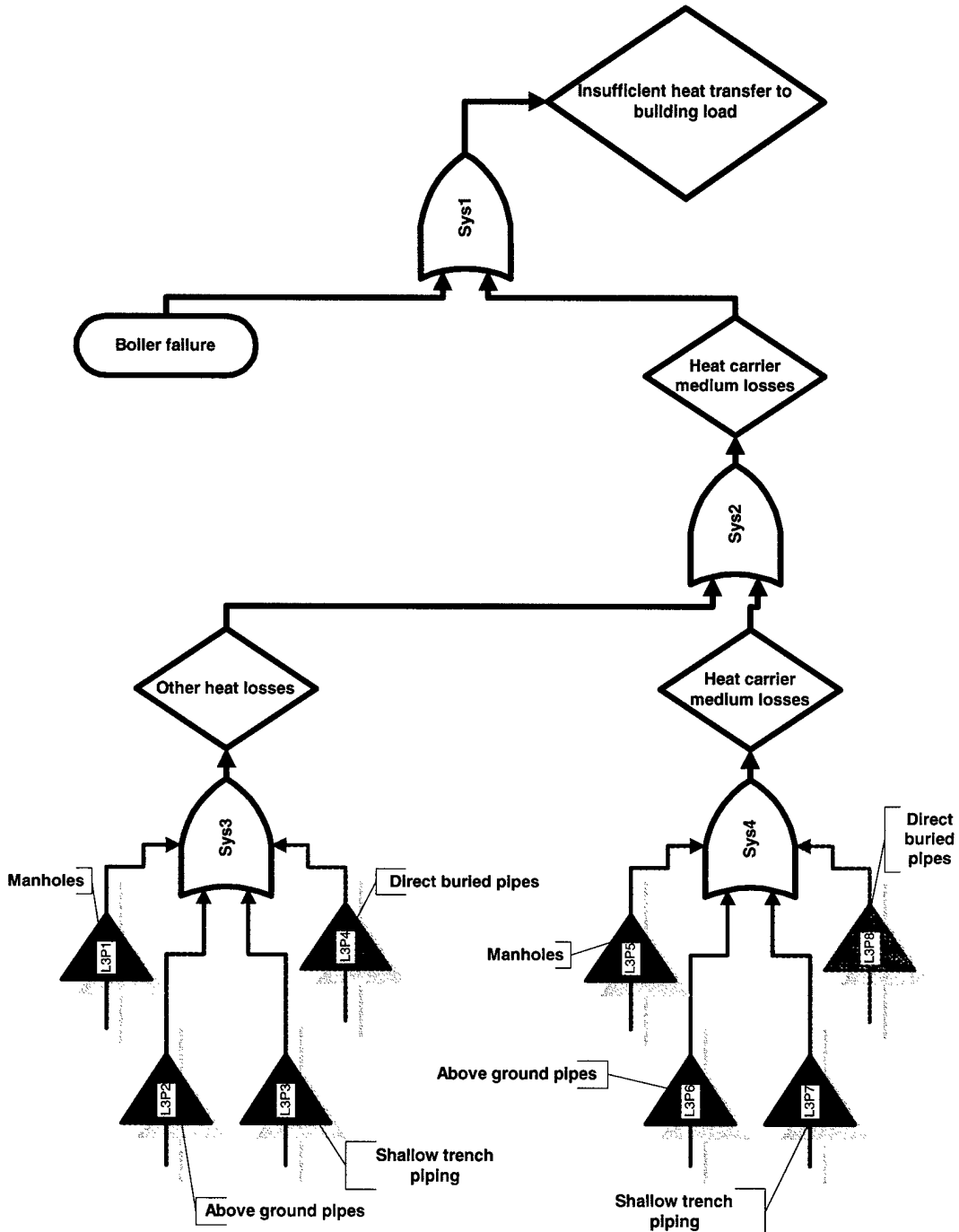

Figure A - 1. Overall heat distribution system fault tree.

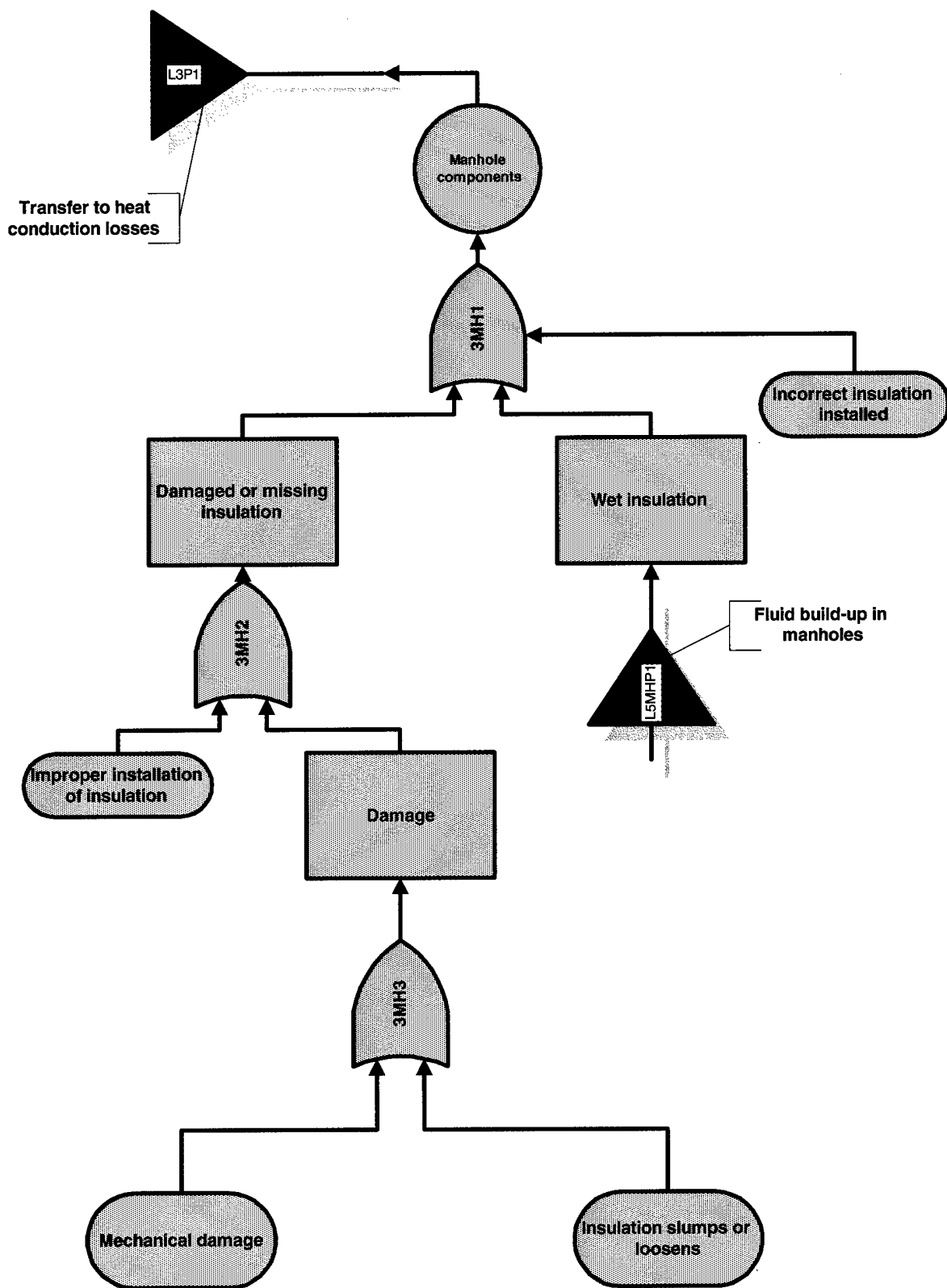

Figure A - 2. Causes of condition heat loss in manholes (inputs to Figure A-1).

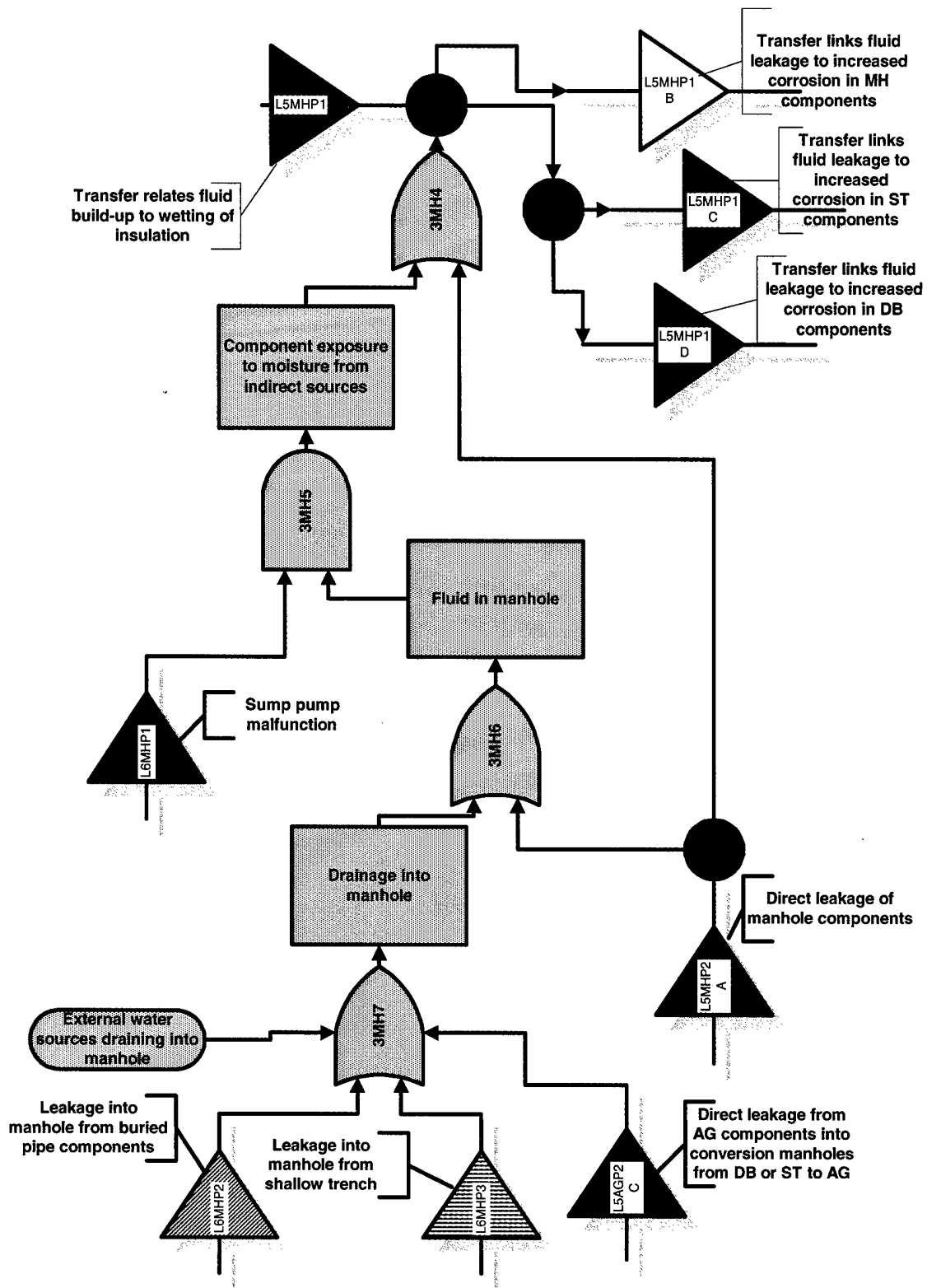

Figure A - 3. Potential sources of fluid build-up in manholes (inputs to Figure A-2).

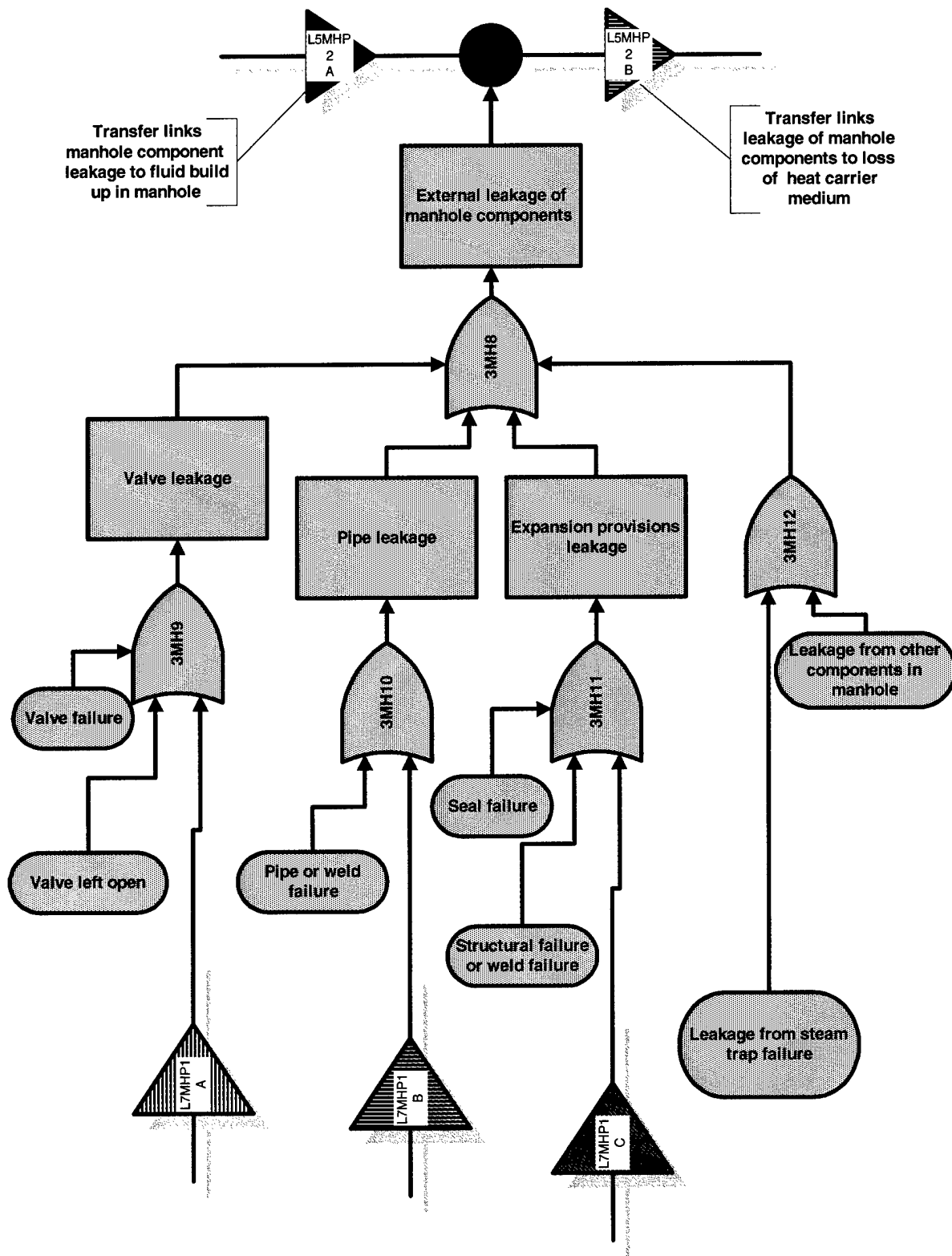

Figure A - 4. Potential sources of direct leakage of manhole components (input to Figure A-3).

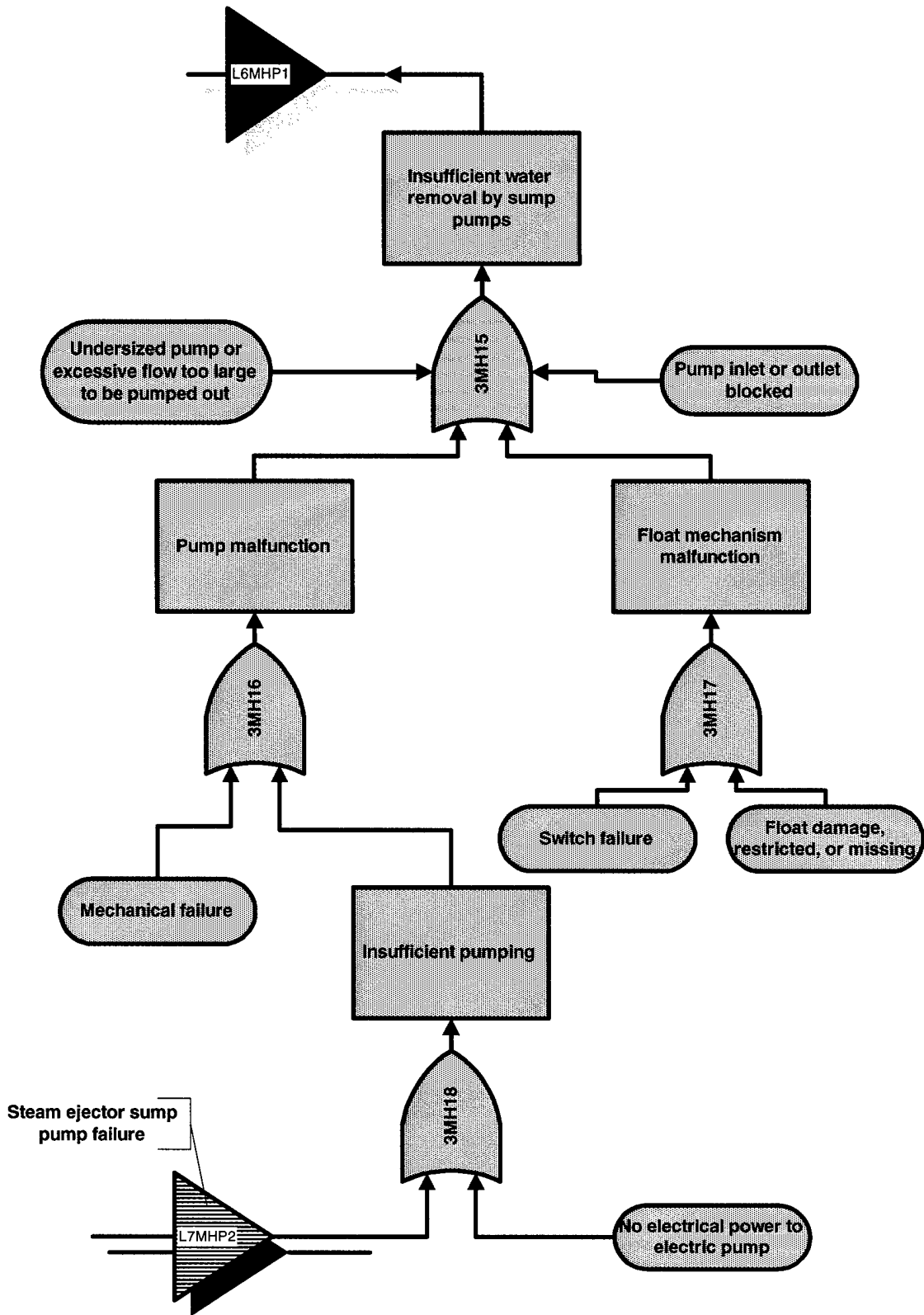

Figure A - 5. Potential causes of sump pump malfunction (input to Figure A-3).

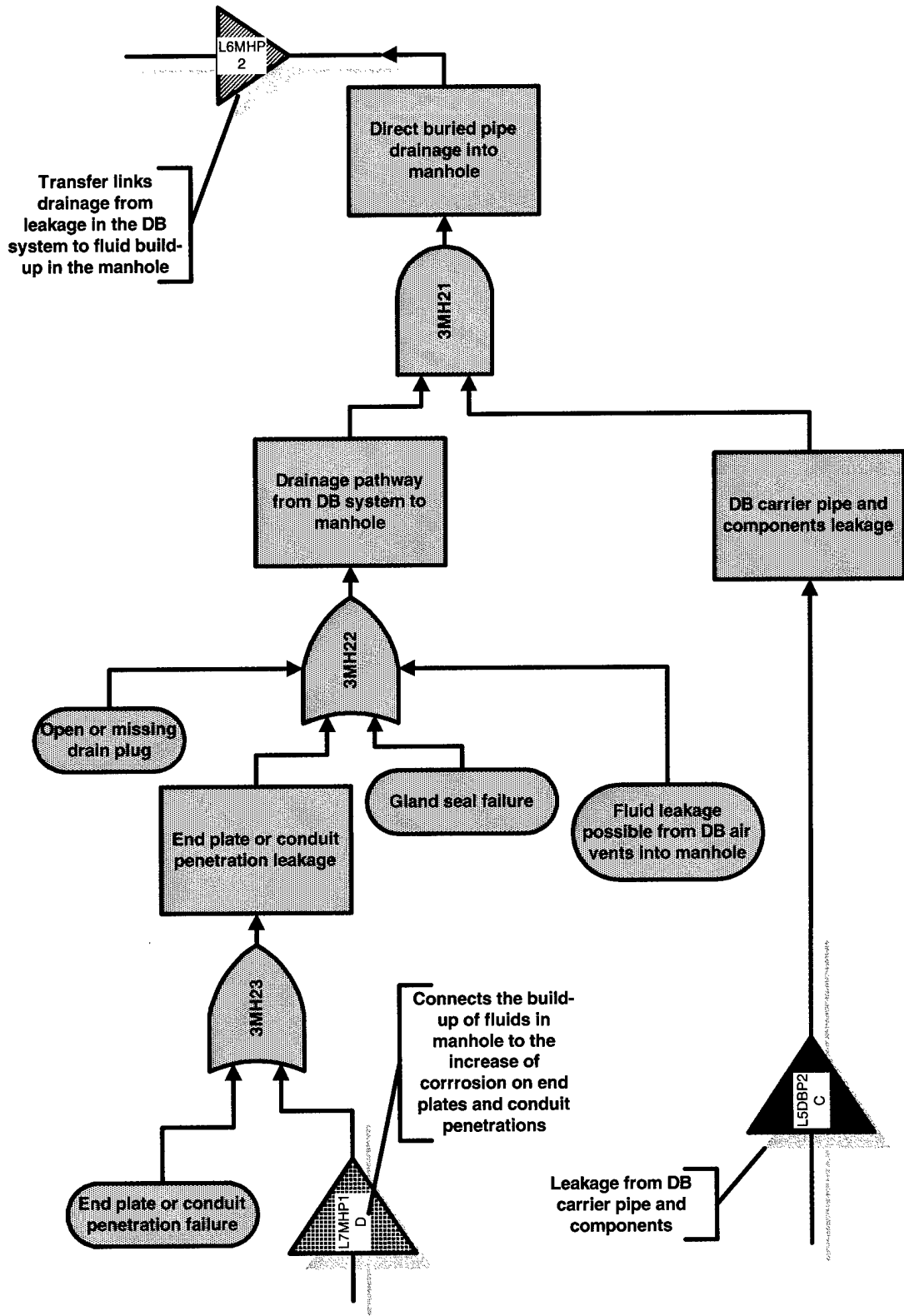

Figure A - 6. Potential sources of leakage into manhole from direct buried pipe components (input to Figure A-3).

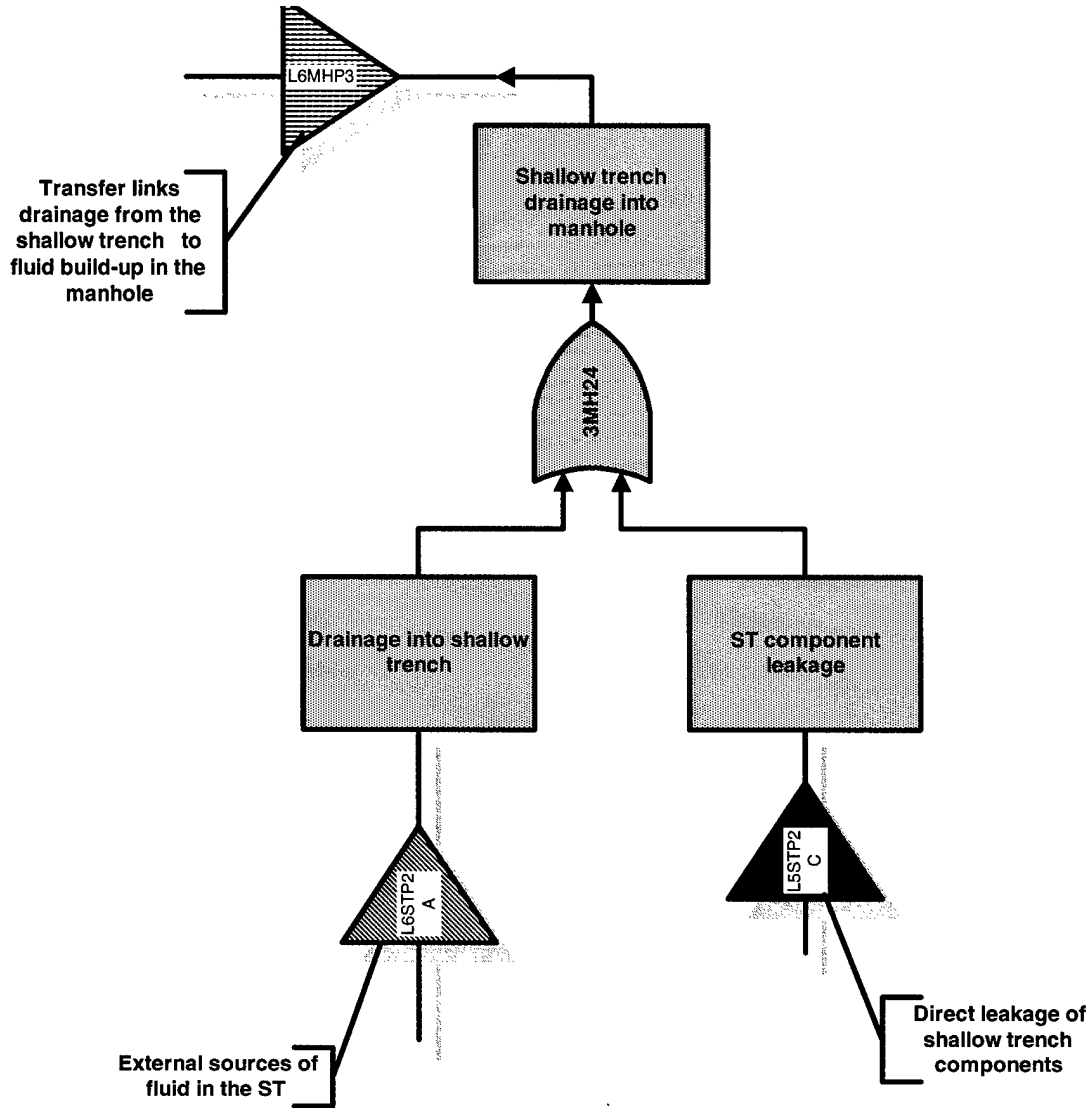

Figure A - 7. Potential sources of leakage into manhole from an associated shallow trench (input into Figure A-3).

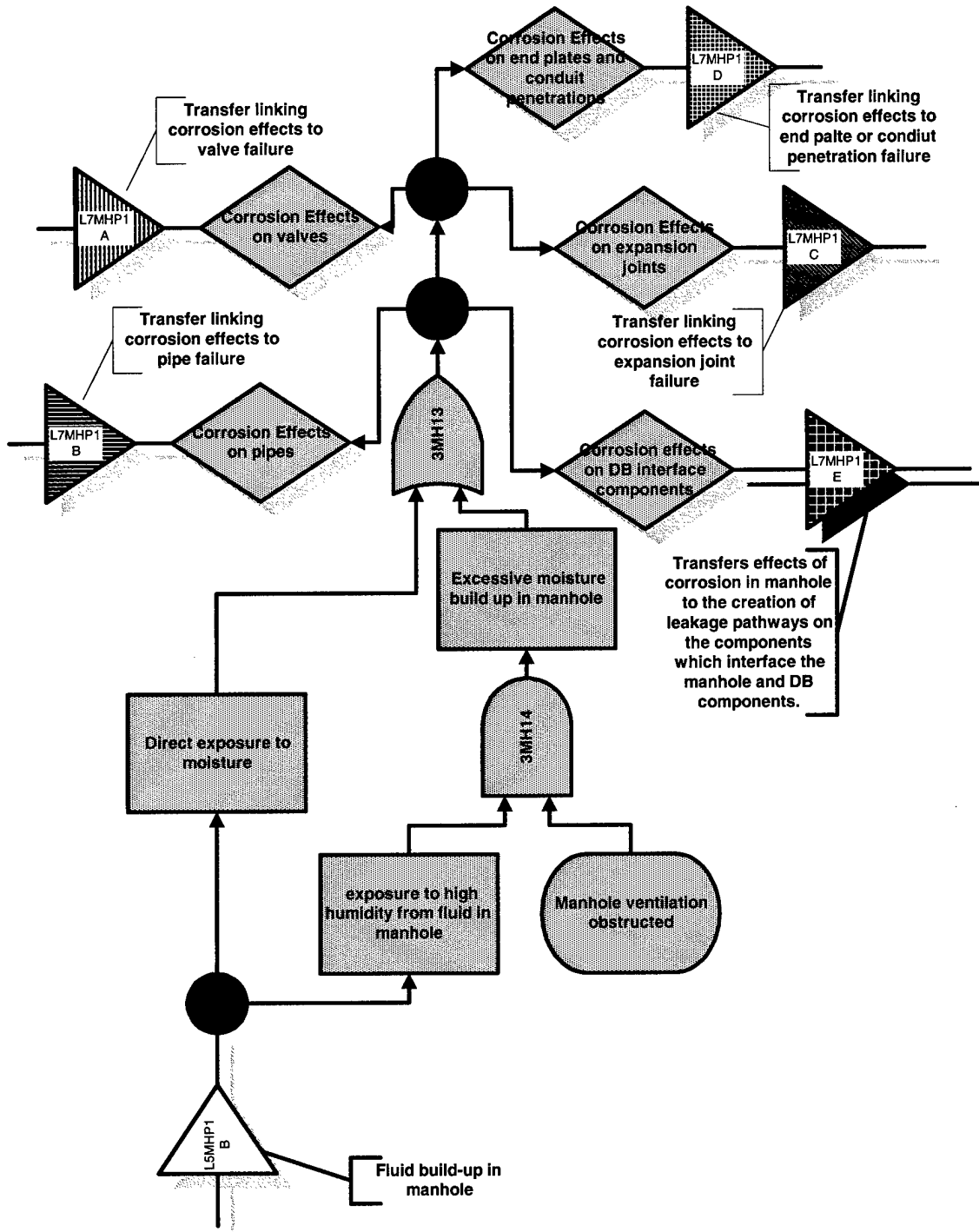

Figure A - 8. Feedback effect of corrosive degradation from moisture of fluid build-up in a manhole (inputs to Figure A-4 and others).

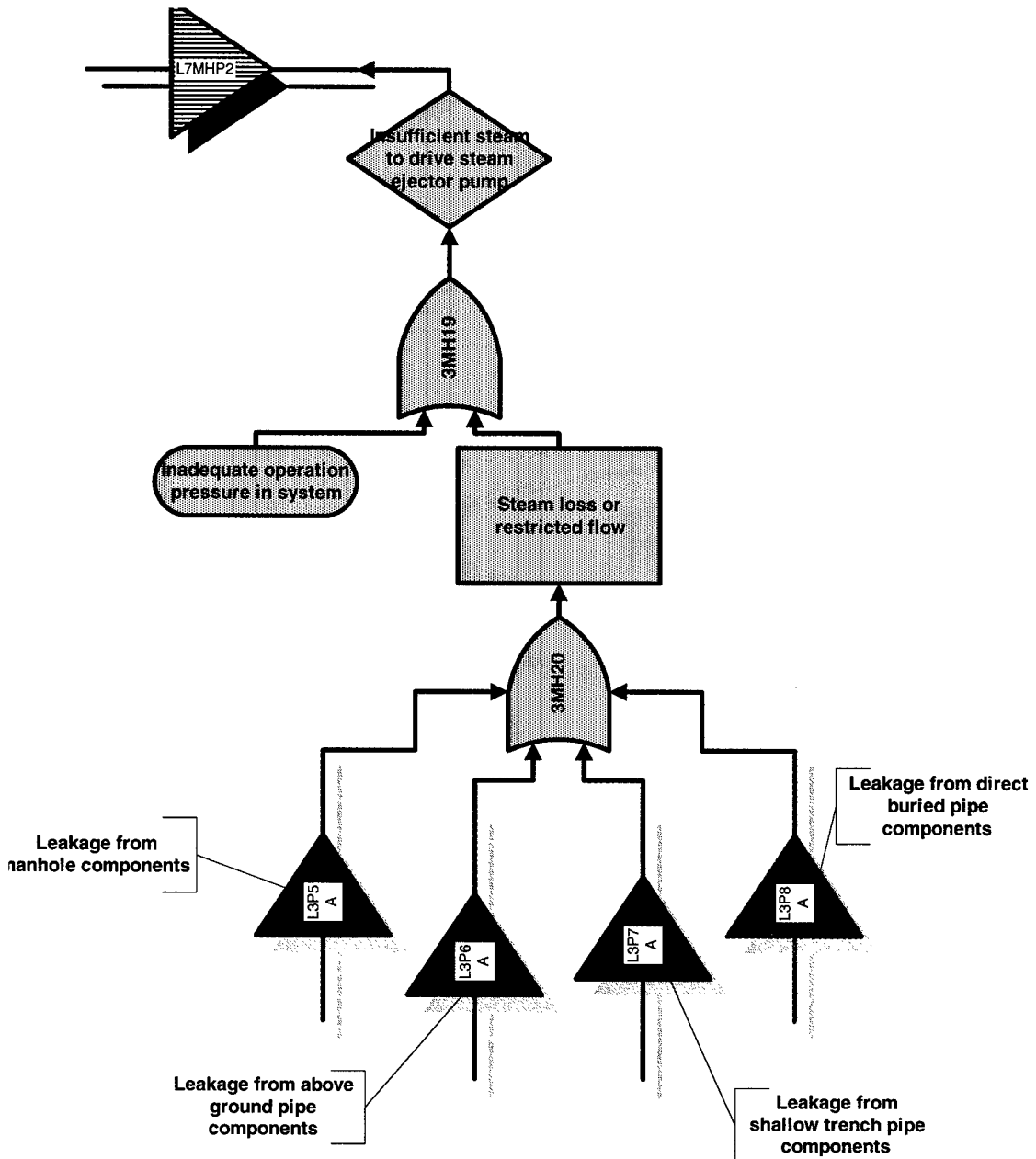

Figure A - 9. Potential causes of carrier pipe steam and/or pressure loss sufficient to prevent effective operation of steam ejector pumps (input into Figure A-5).

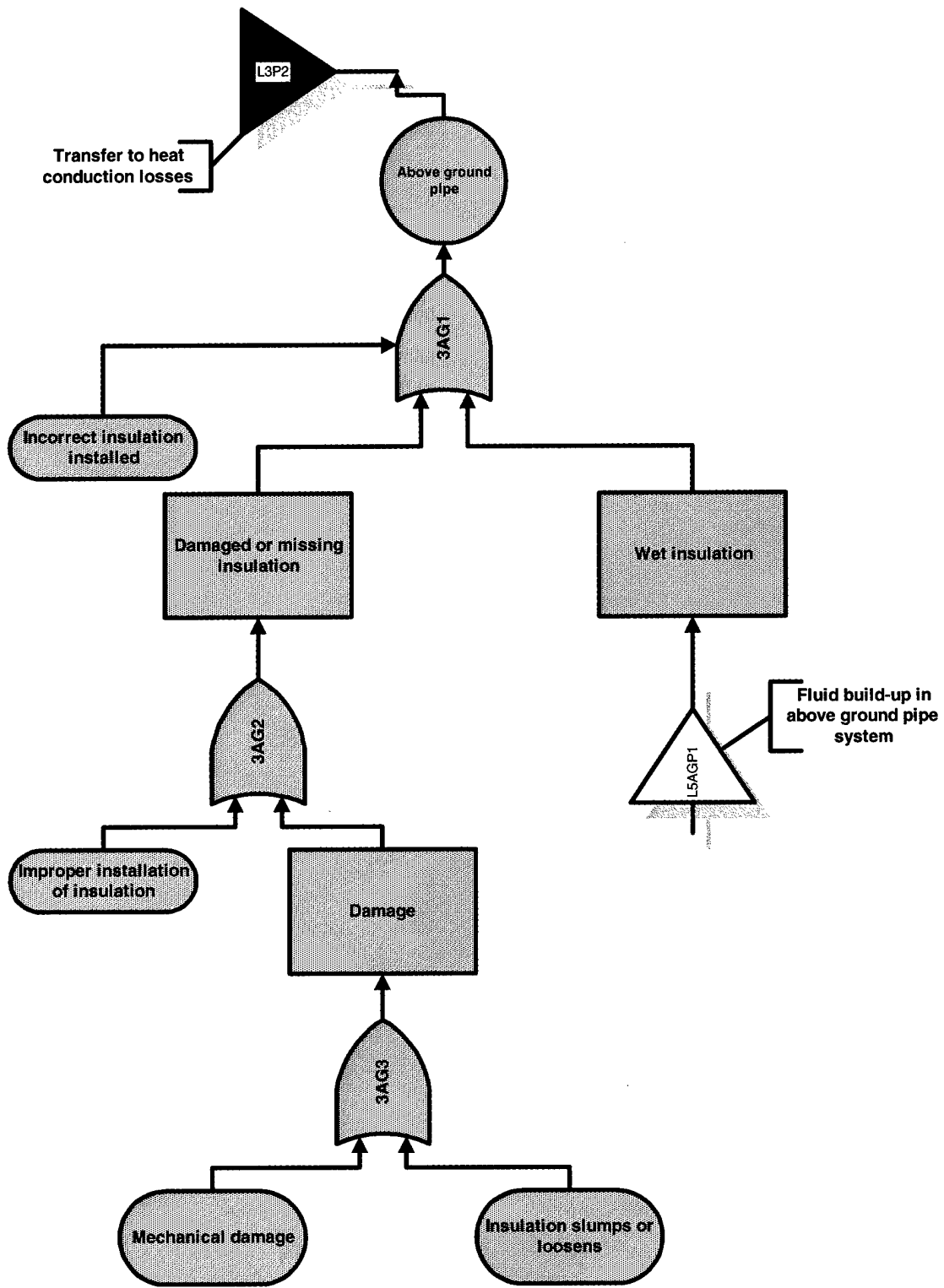

Figure A - 10. Causes of conduction heat loss for above ground piping (input to Figure A-1).

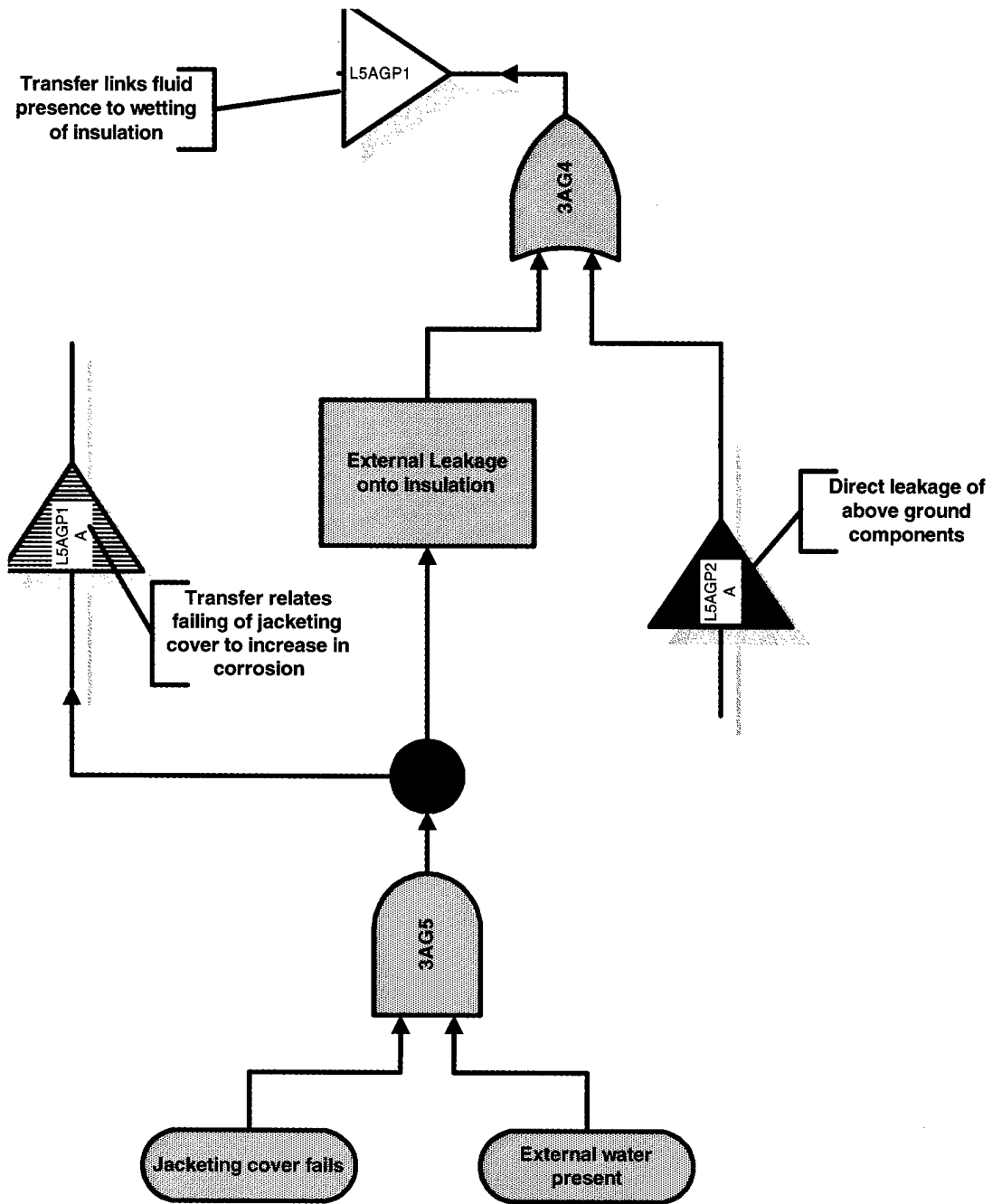

Figure A - 11. Potential causes of wet insulation in above ground piping (input to Figure A-10).

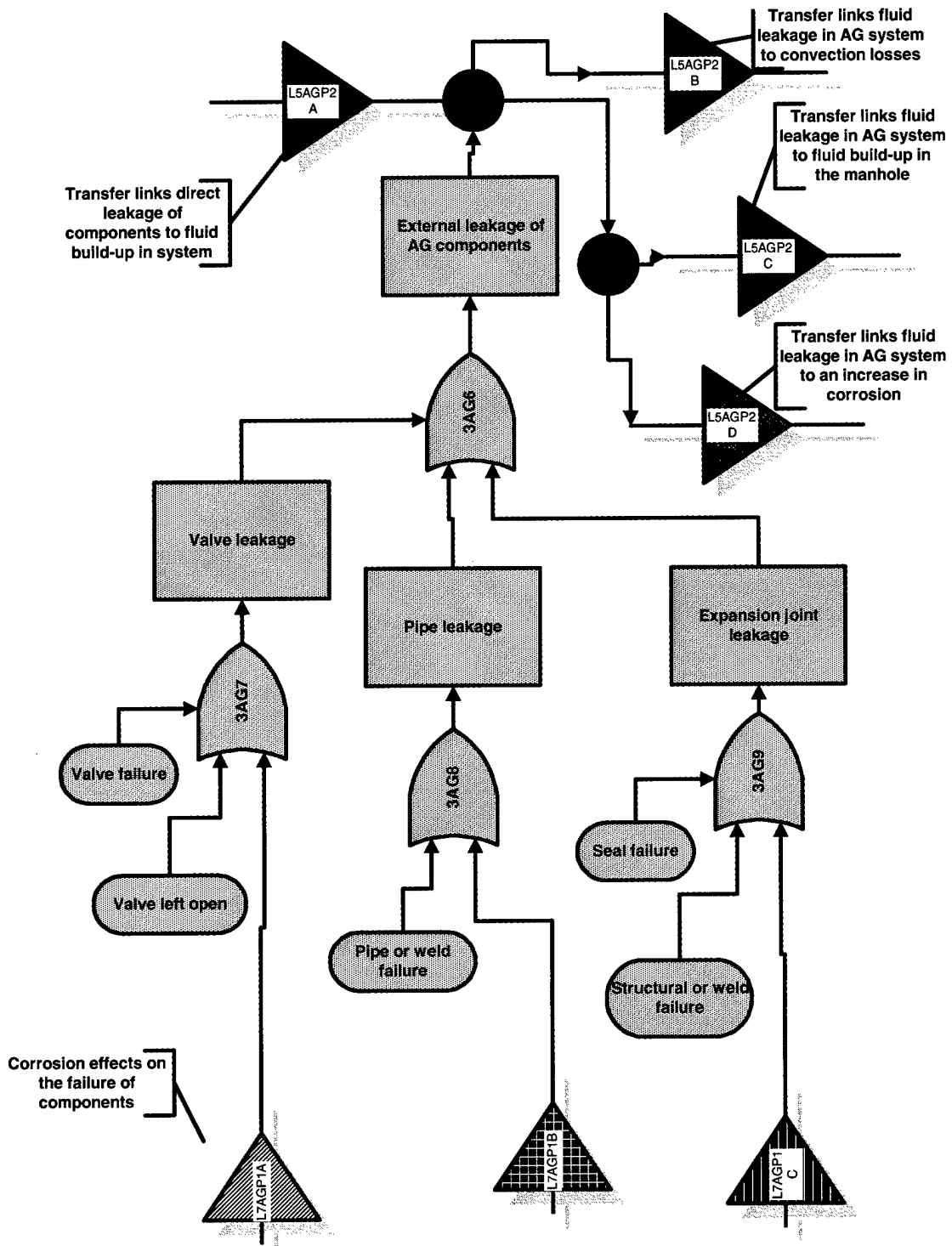

Figure A - 12. Potential causes of carrier pipe leakage in above ground systems (input to A-11).

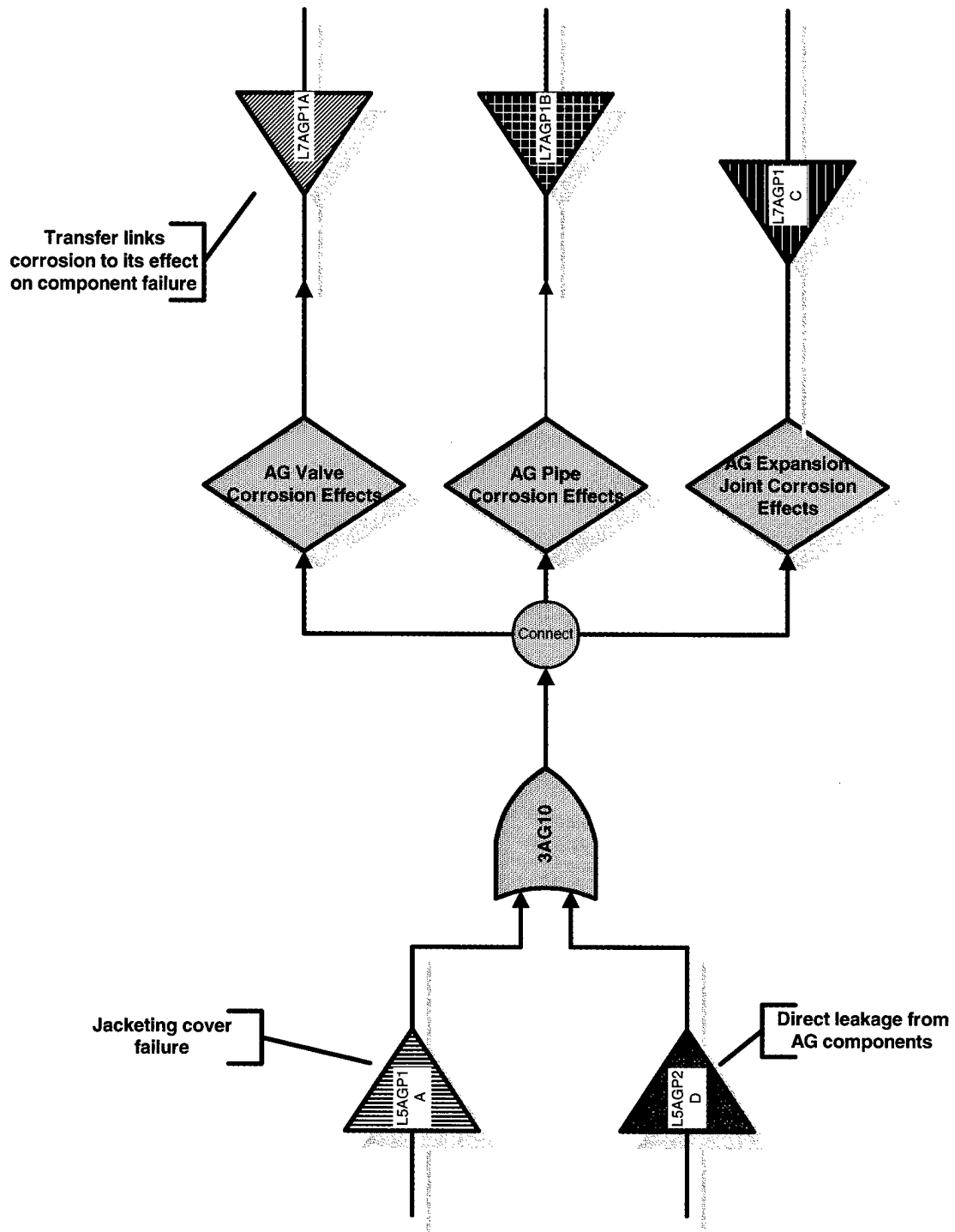

Figure A - 13. Feedback effects of corrosive degradation from both external and internal sources on carrier pipe leakage in above ground systems (input to Figure A-12).

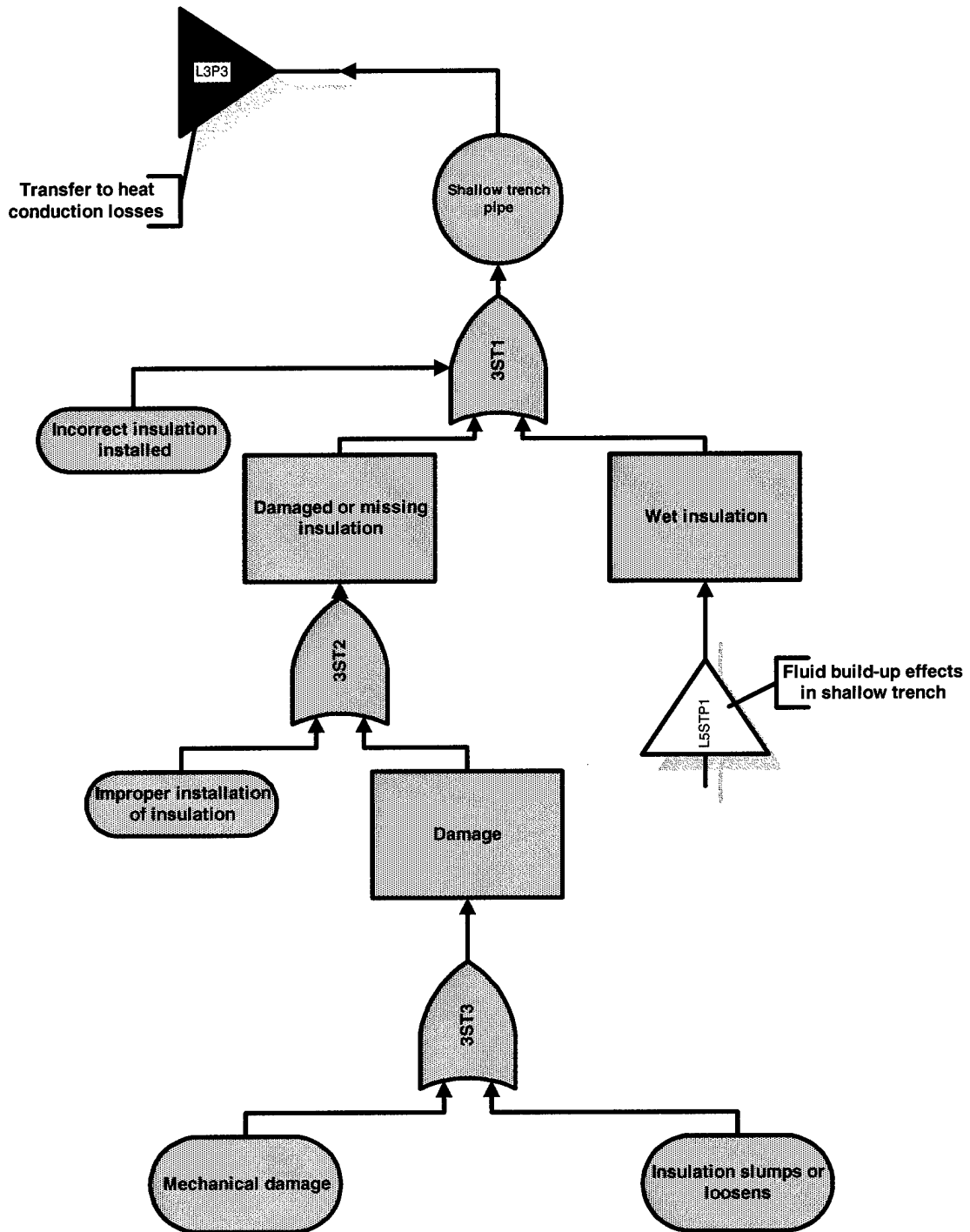

Figure A - 14. Causes of conduction heat loss for shallow trench piping (input to Figure A-1).

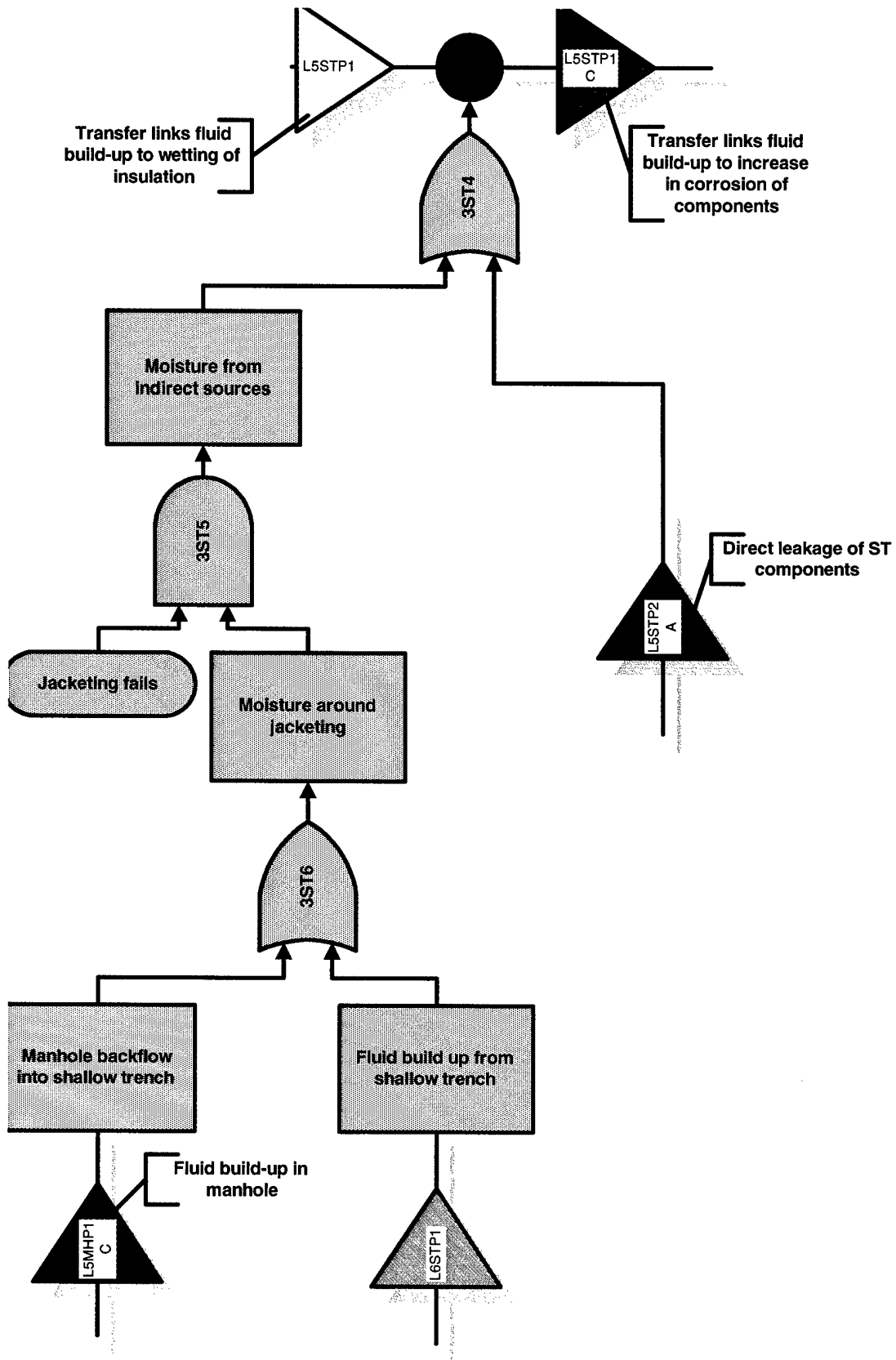

Figure A - 15. Potential causes of wet insulation in shallow trench piping (input to Figure A-14).

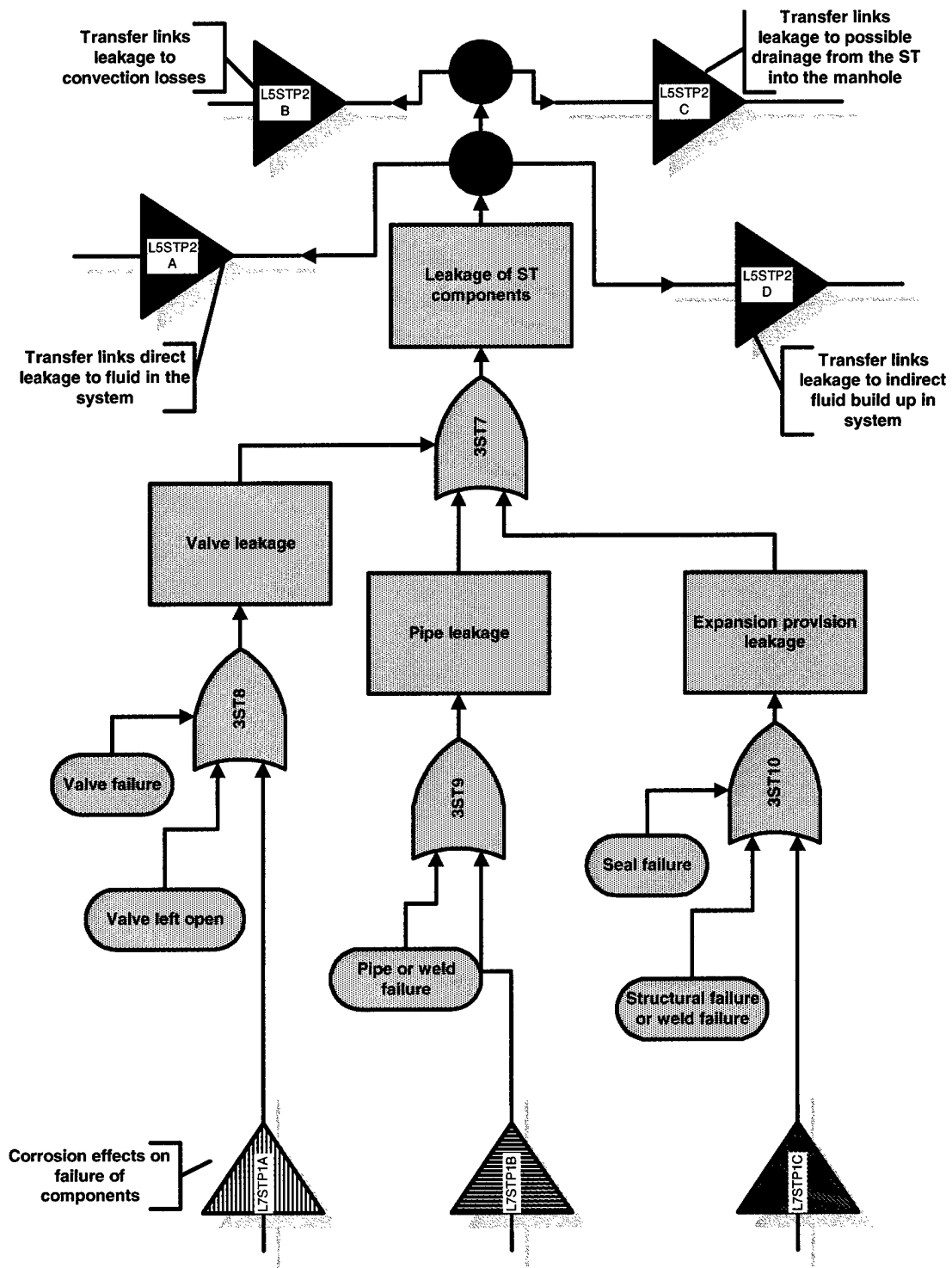

Figure A - 16. Potential causes for carrier pipe leakage in a shallow trench system (inputs to Figures A-15, A-17, and others).

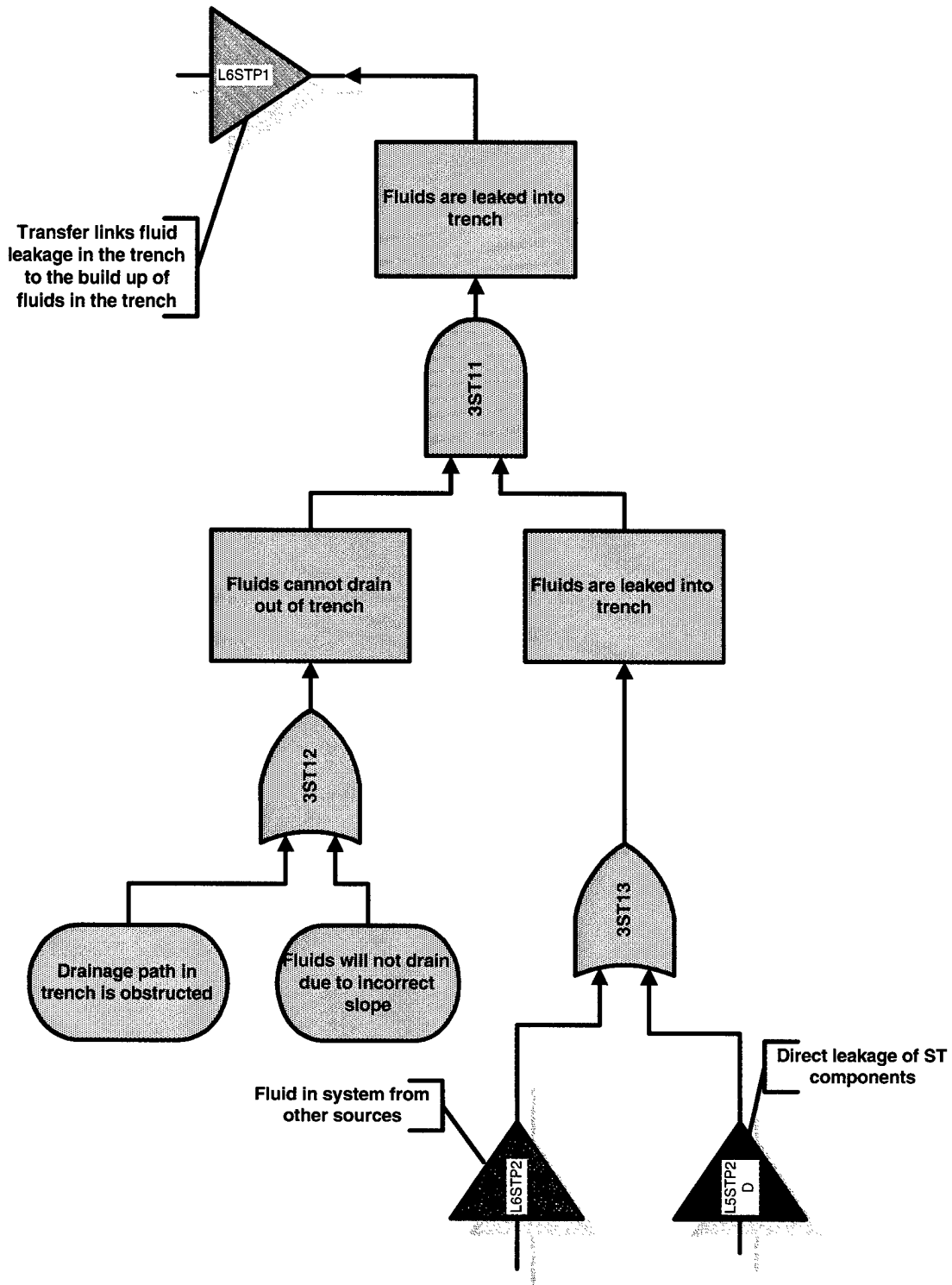

Figure A - 17. Potential sources of water or water build-up within the shallow trench (inputs to Figure A-15).

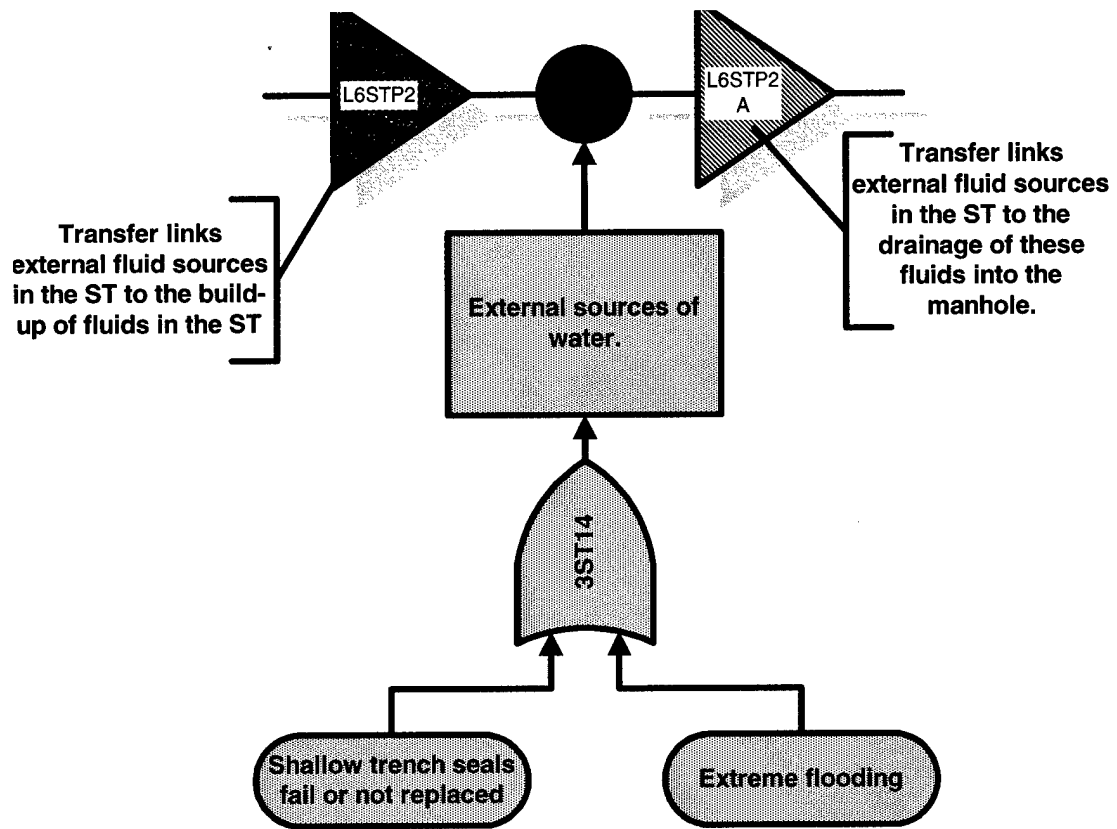

Figure A - 18. Potential sources of external water in shallow trench (input to Figure A-17).

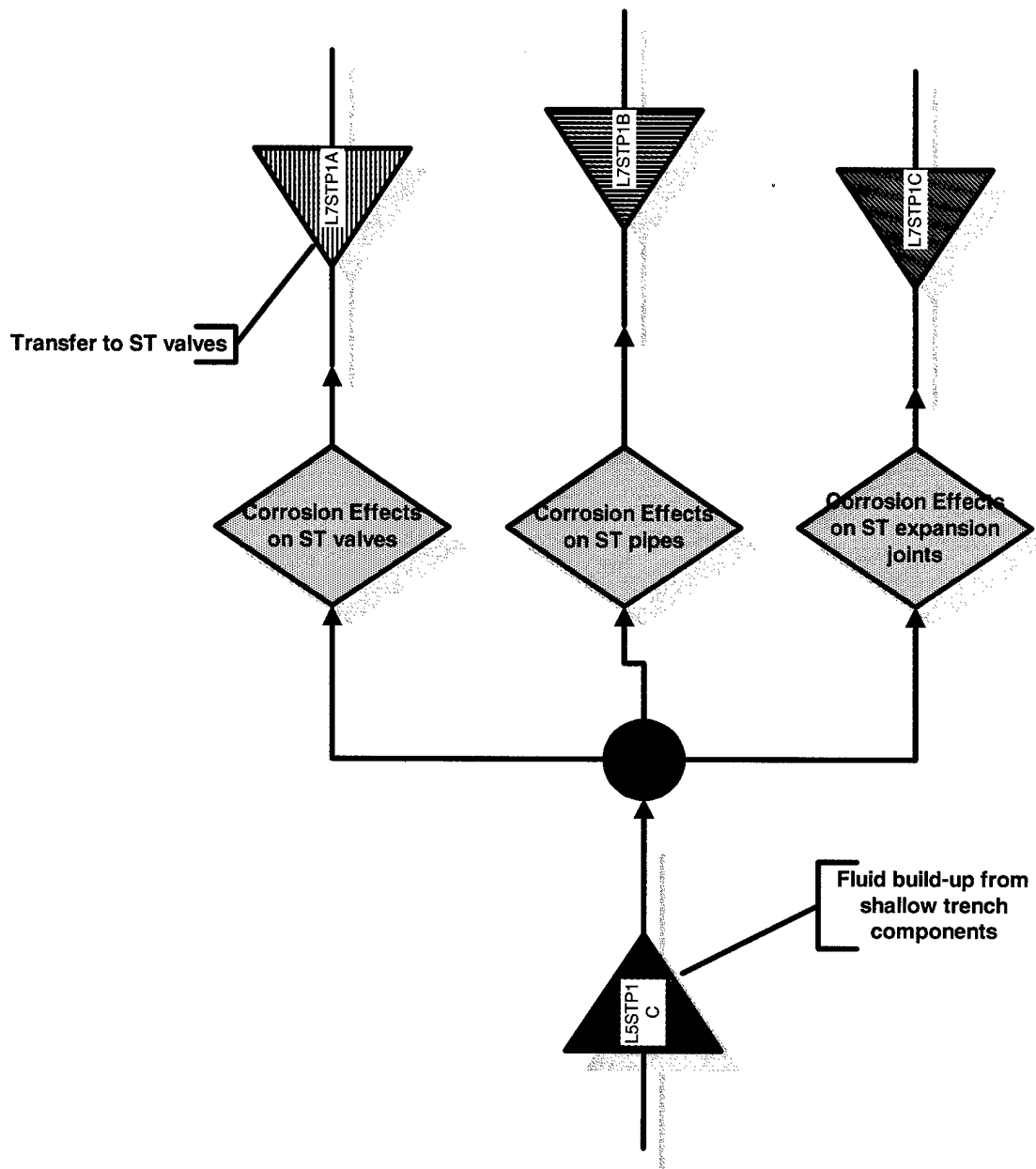

Figure A - 19. Feedback effect of corrosive degradation on carrier pipe leakage derived from internal and external sources of water within the shallow trench (input to Figure A-16).

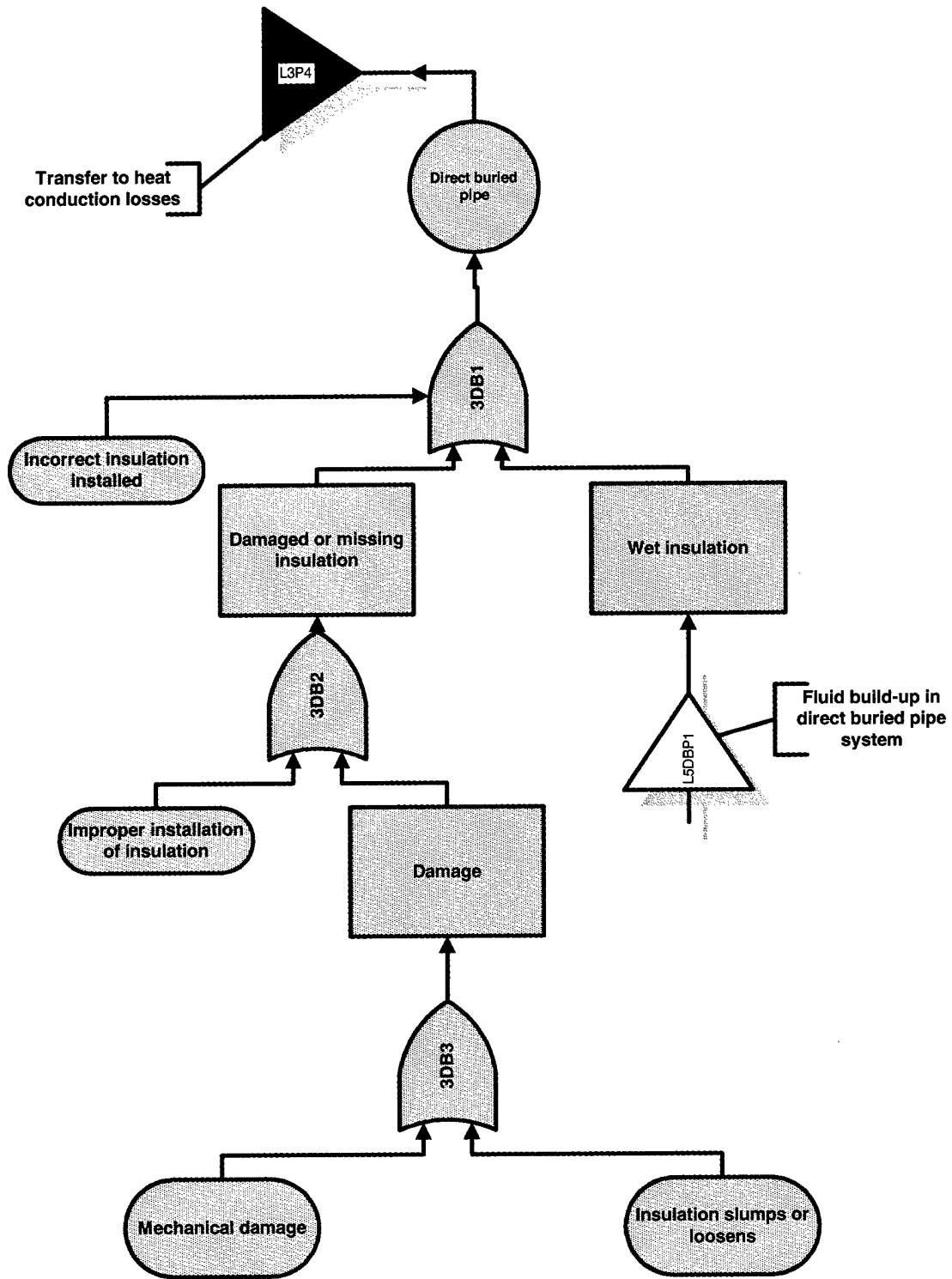

Figure A - 20. Causes of conduction heat losses in direct buried piping (inputs to Figure A-1).

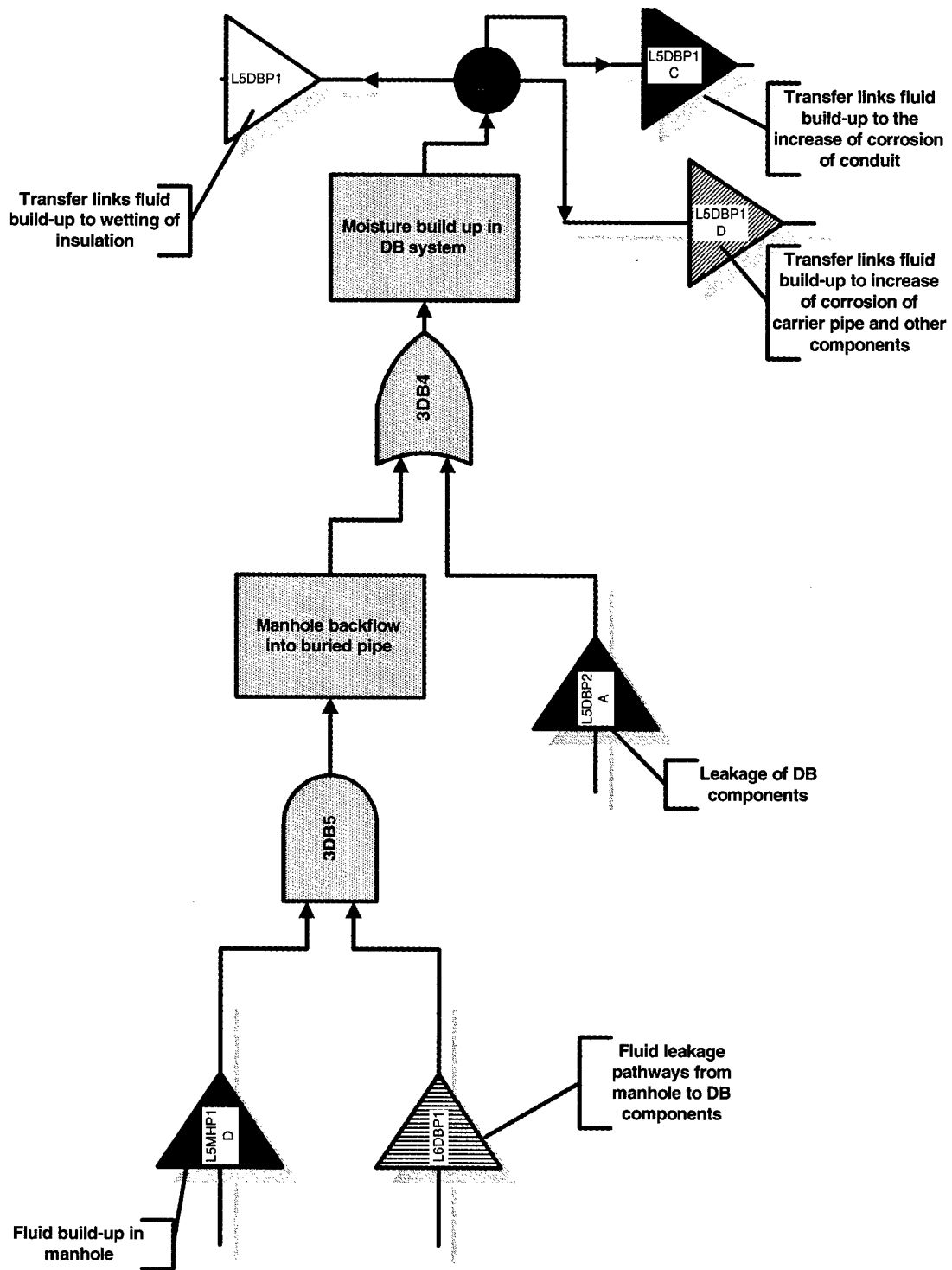

Figure A - 21. Potential sources of fluid build-up (i.e., insulation wetting) within the annular spaces of direct buried piping (input to Figure A-20).

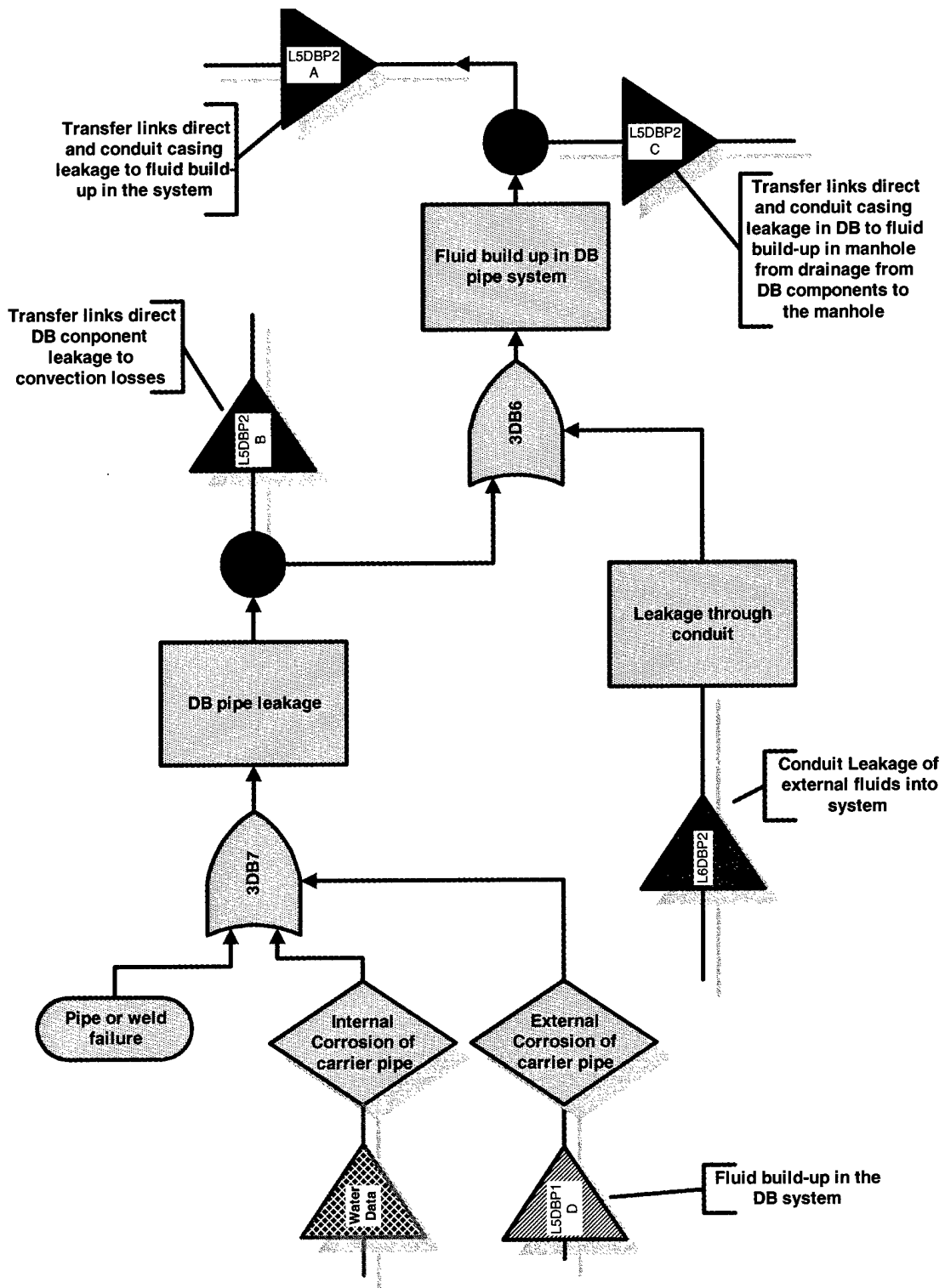

Figure A - 22. Potential sources, both external and internal, of water build-up within the annular spaces from carrier piping or conduit failure (input to Figure A-21).

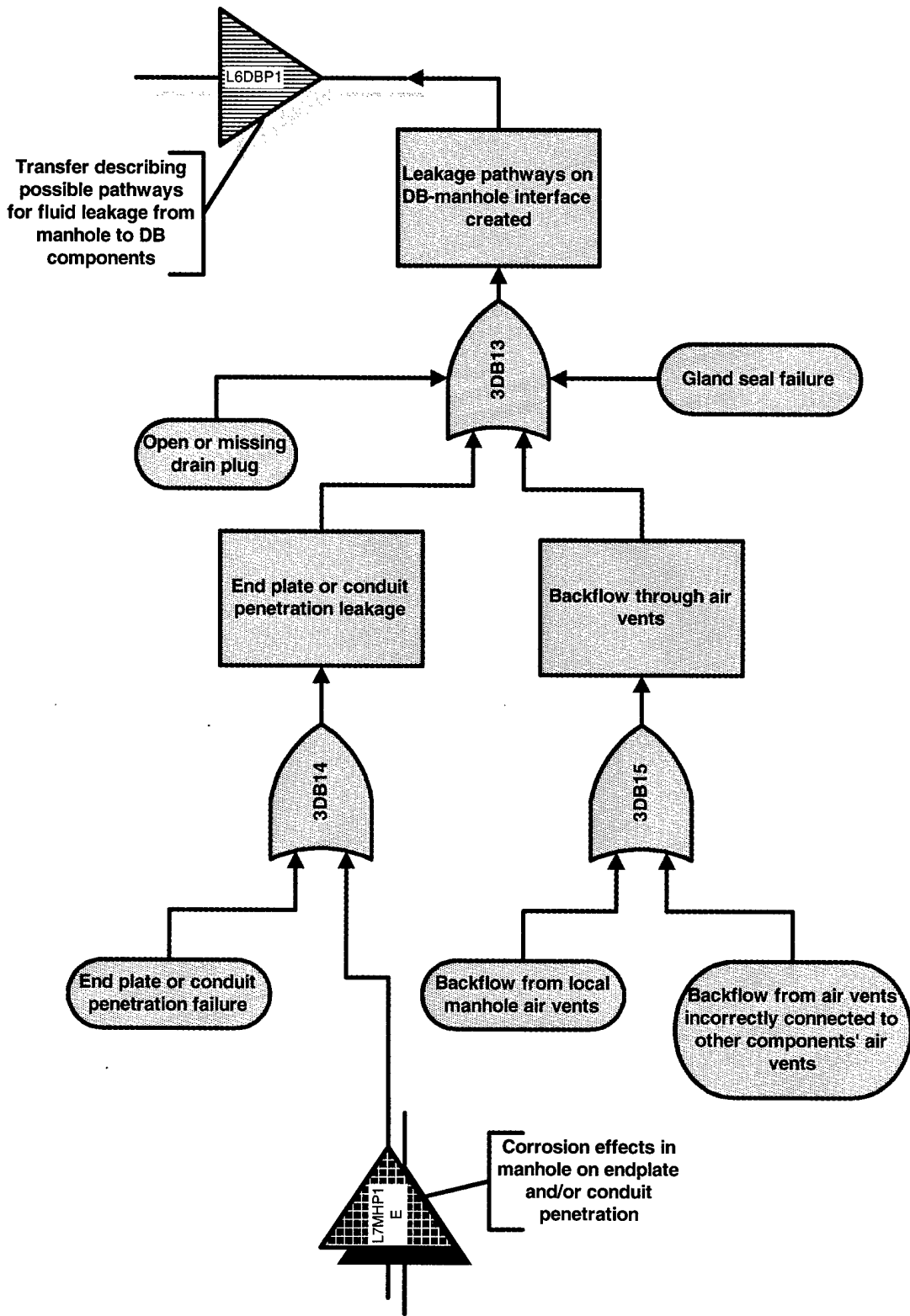

Figure A - 23. Potential sources of water in direct buried piping annular space derived from a manhole (input to Figure A-21).

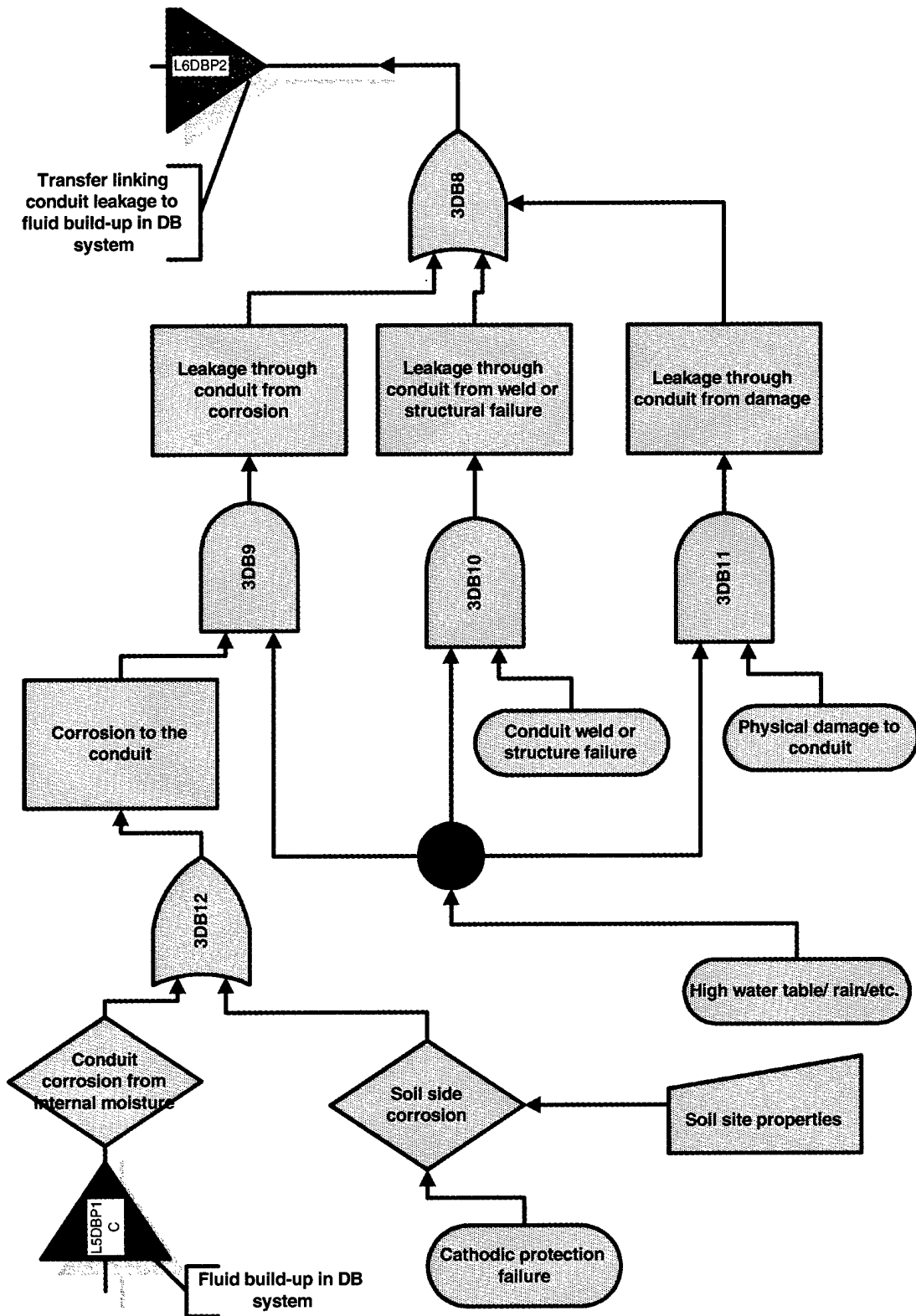

Figure A - 24. Potential causes of conduit failure giving rise to external leakage into annular spaces (input to Figure A-22).

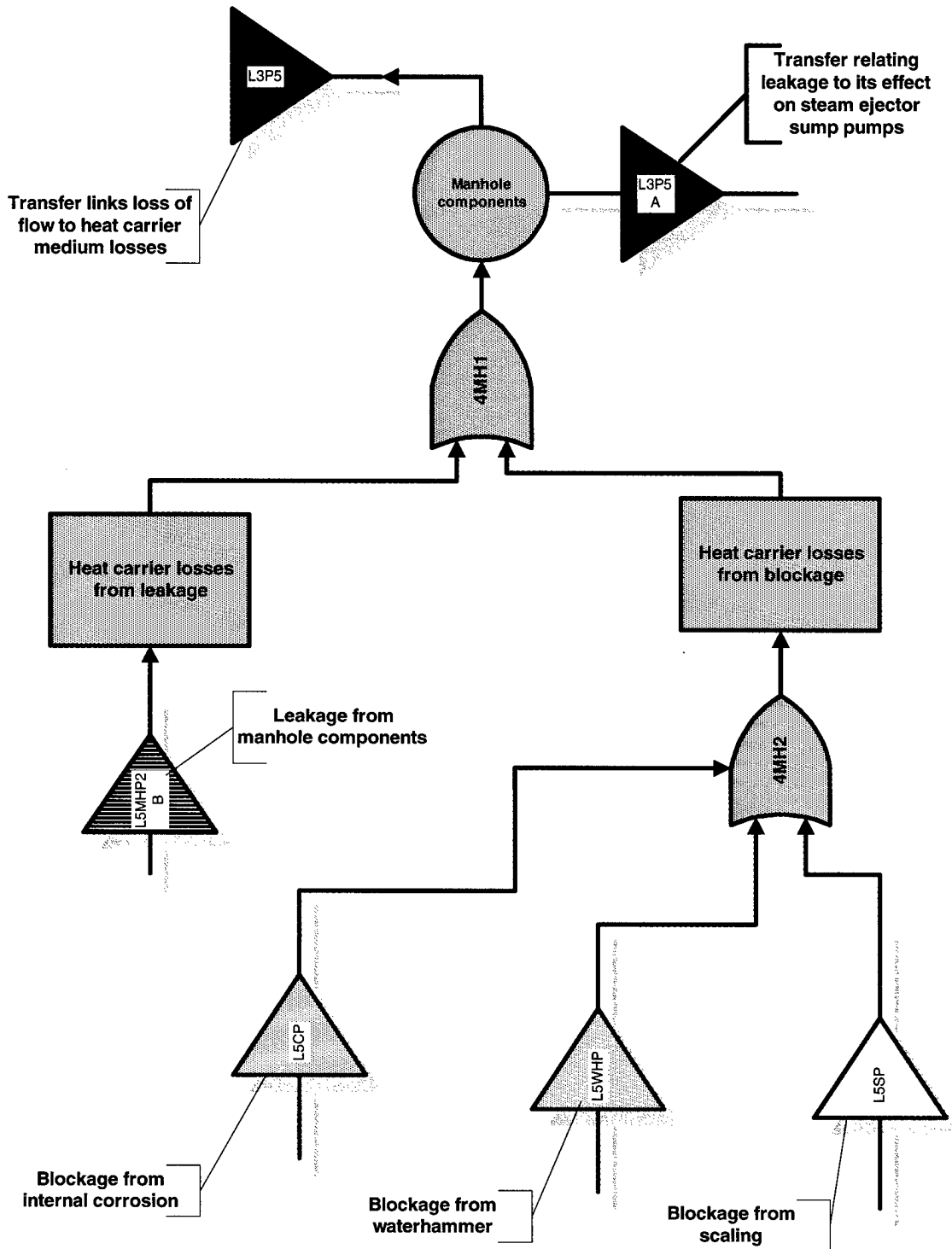

Figure A - 25. Causes of heat carrier medium losses in manholes (input to Figure A-1).

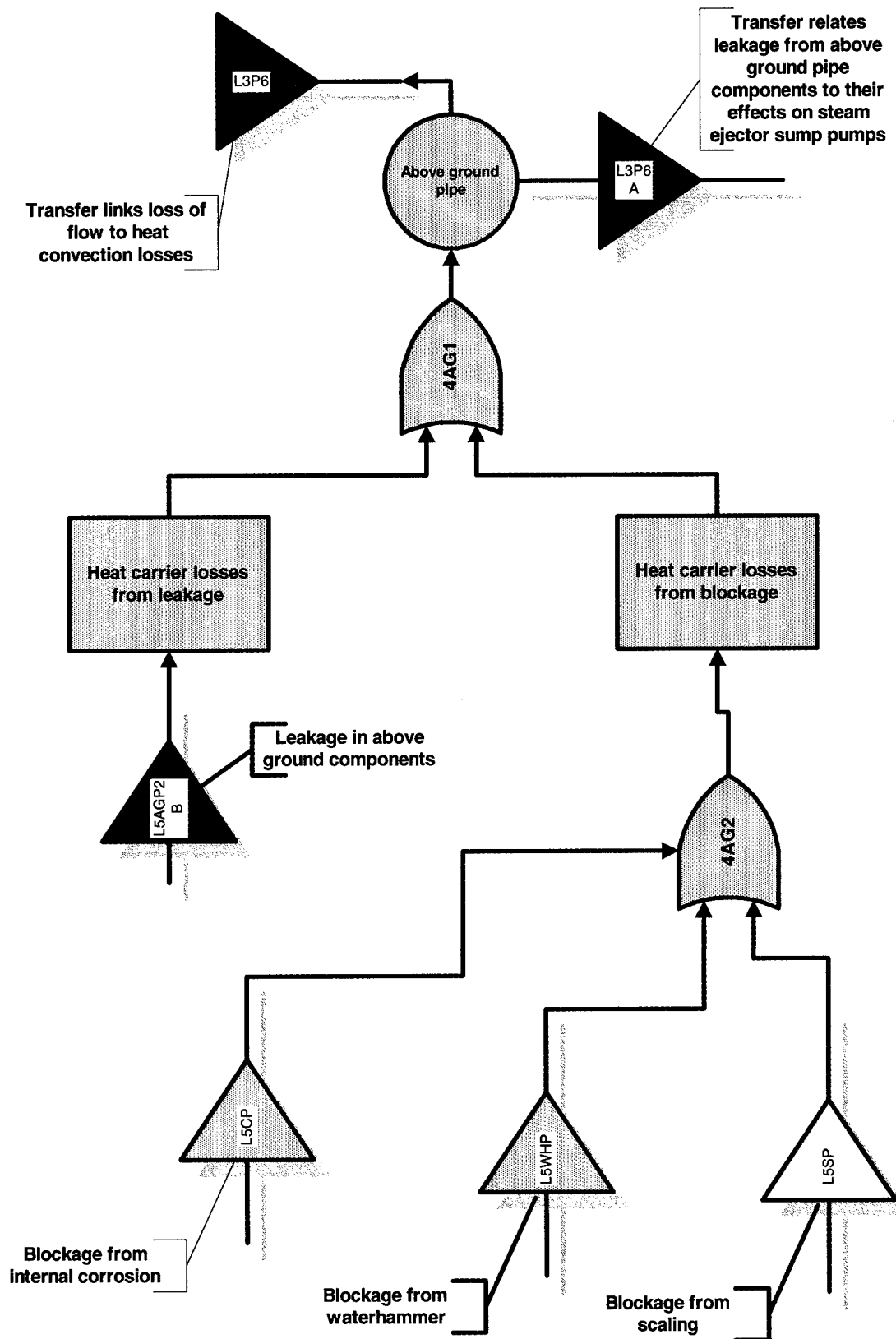

Figure A - 26. Causes of heat carrier medium losses in above ground piping (input to Figure A-1).

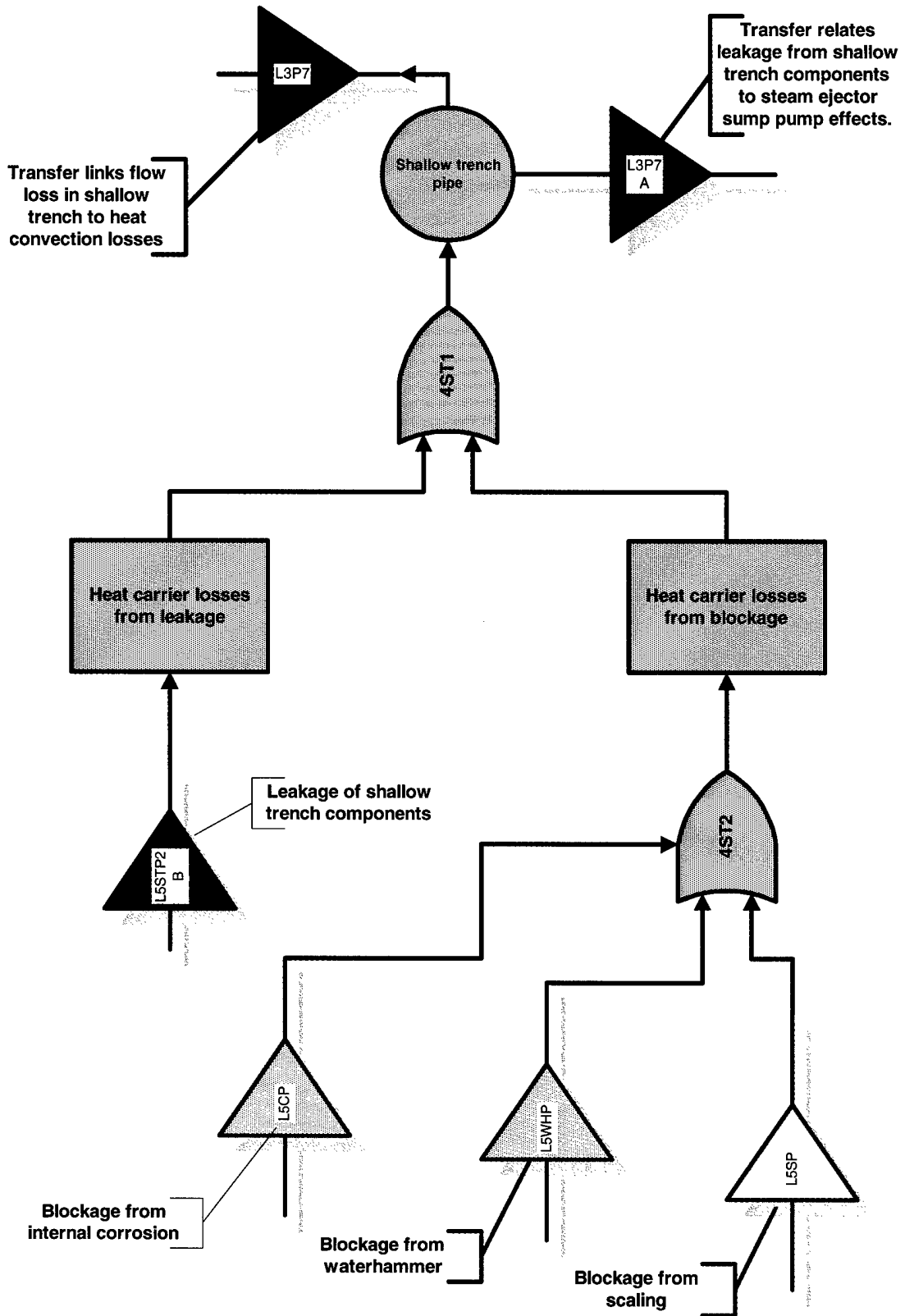

Figure A - 27. Causes of heat carrier medium losses in shallow trench piping (input to Figure A-1).

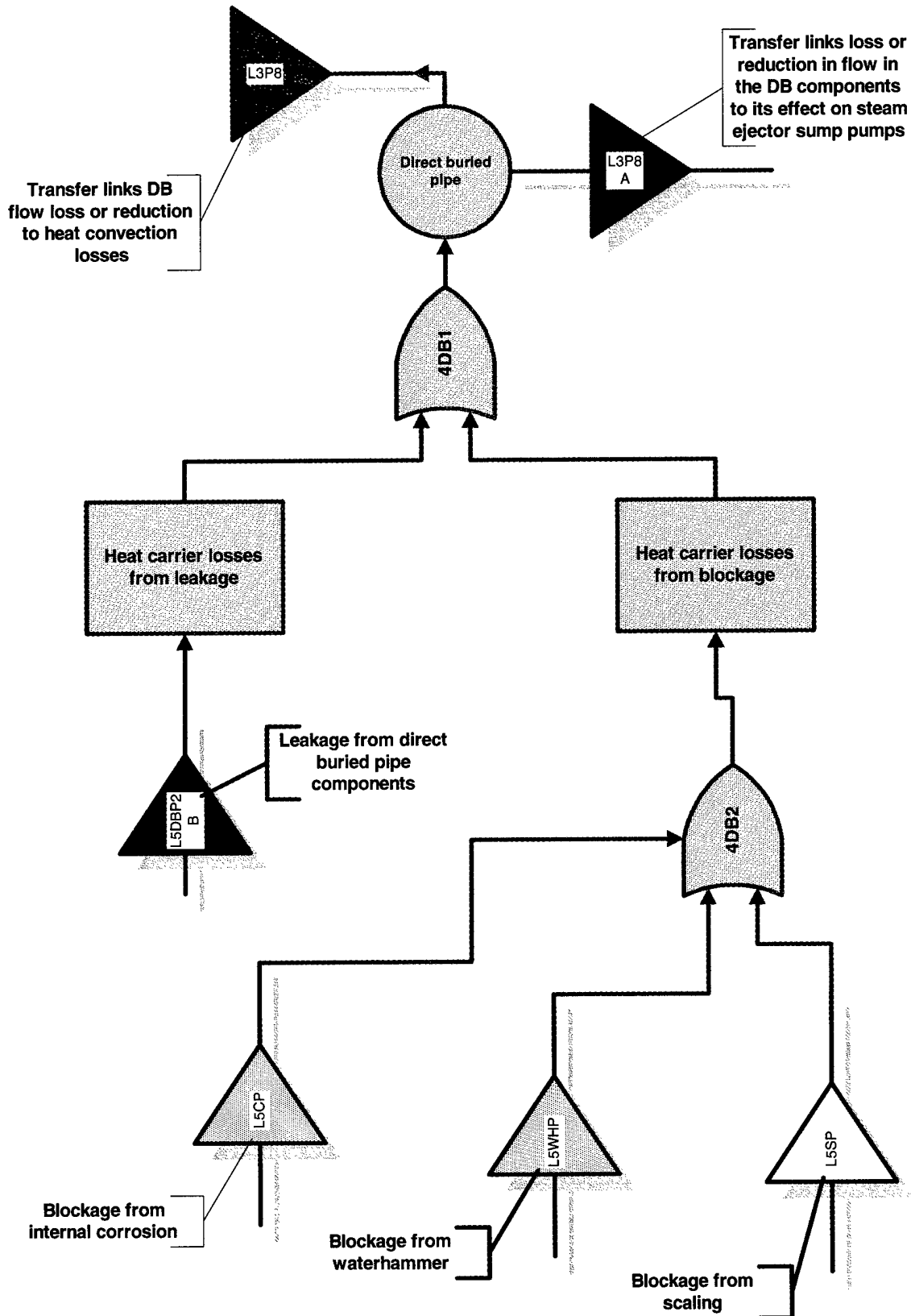

Figure A - 28. Causes of heat carrier medium losses in direct buried piping (inputs to Figure A-1).

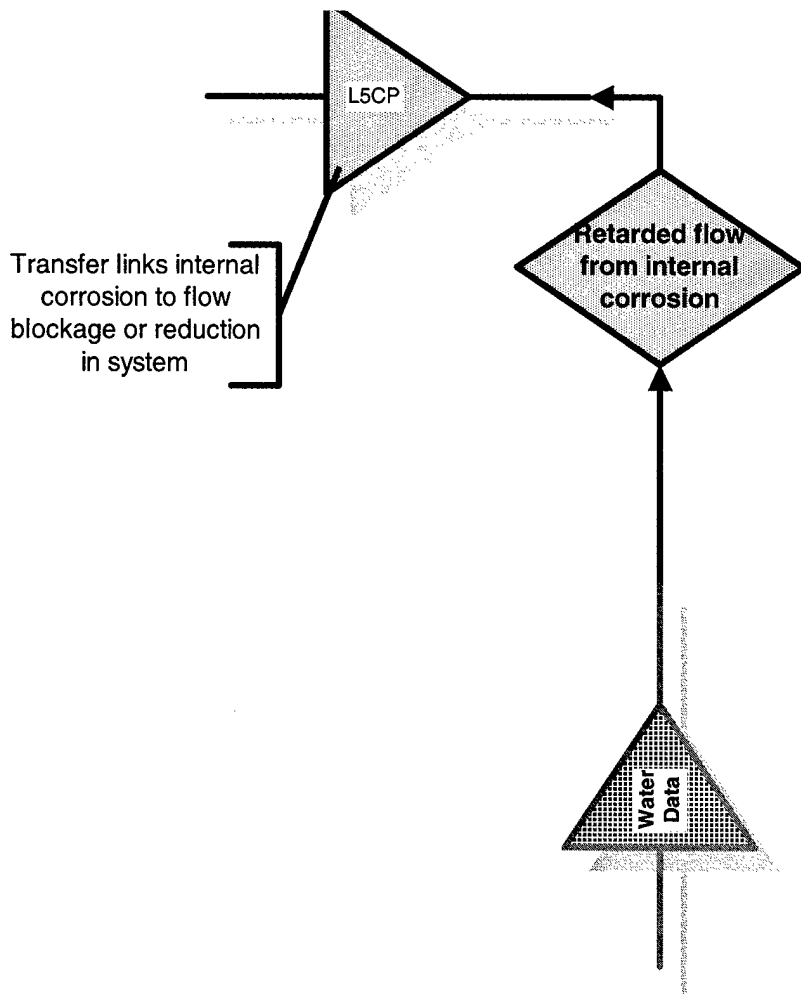

Figure A - 29. Potential cause of carrier pipe internal corrosion giving rise to flow reduction or blockage (input to Figure A-25).

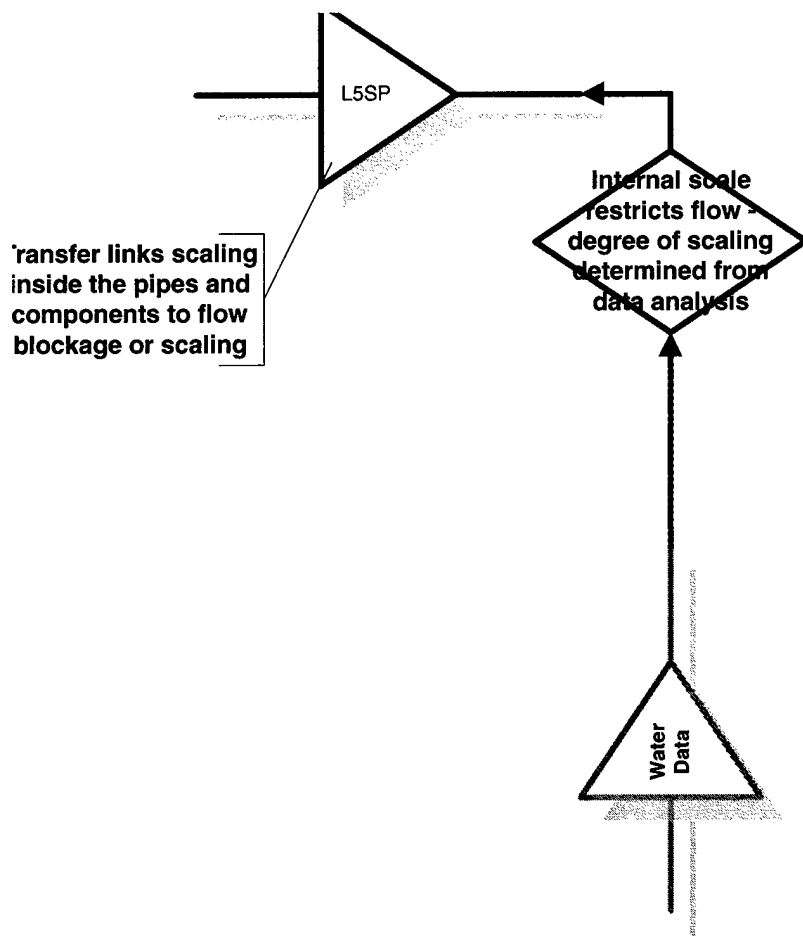

Figure A - 30. Potential cause of carrier pipe internal scaling giving rise to flow reduction or blockage (input to Figure A-25).

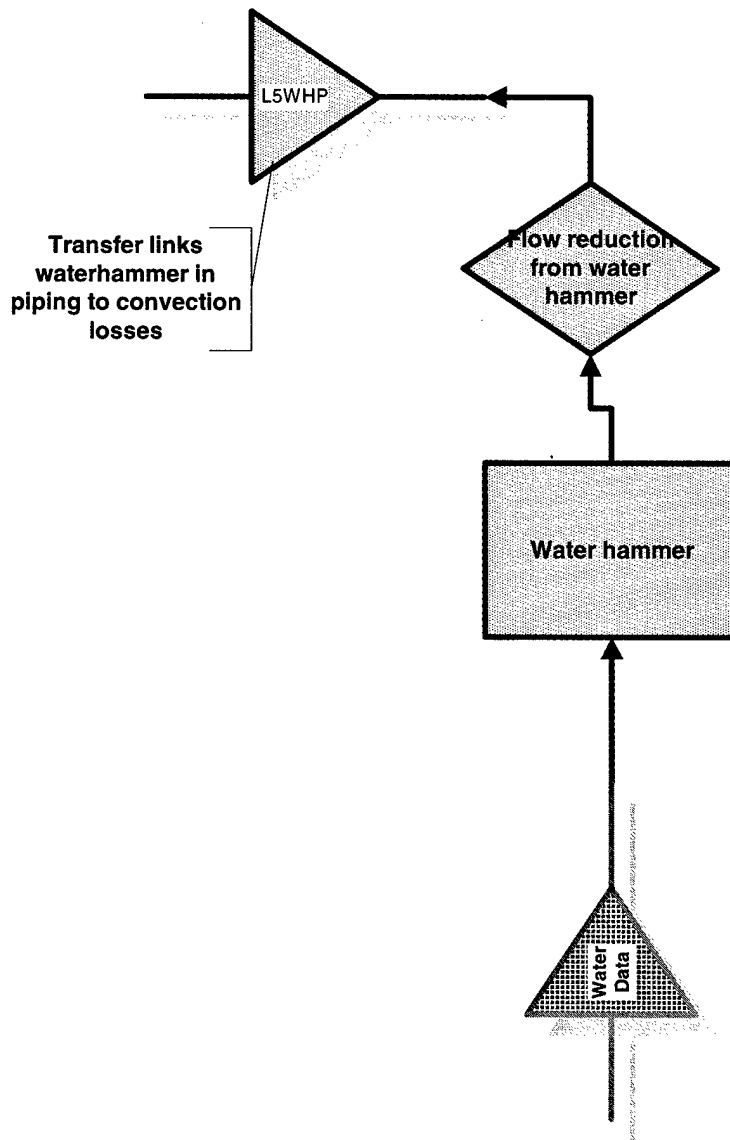

Figure A - 31. Potential cause of carrier pipe flow reduction derived from water hammer (input to Figure A-25).

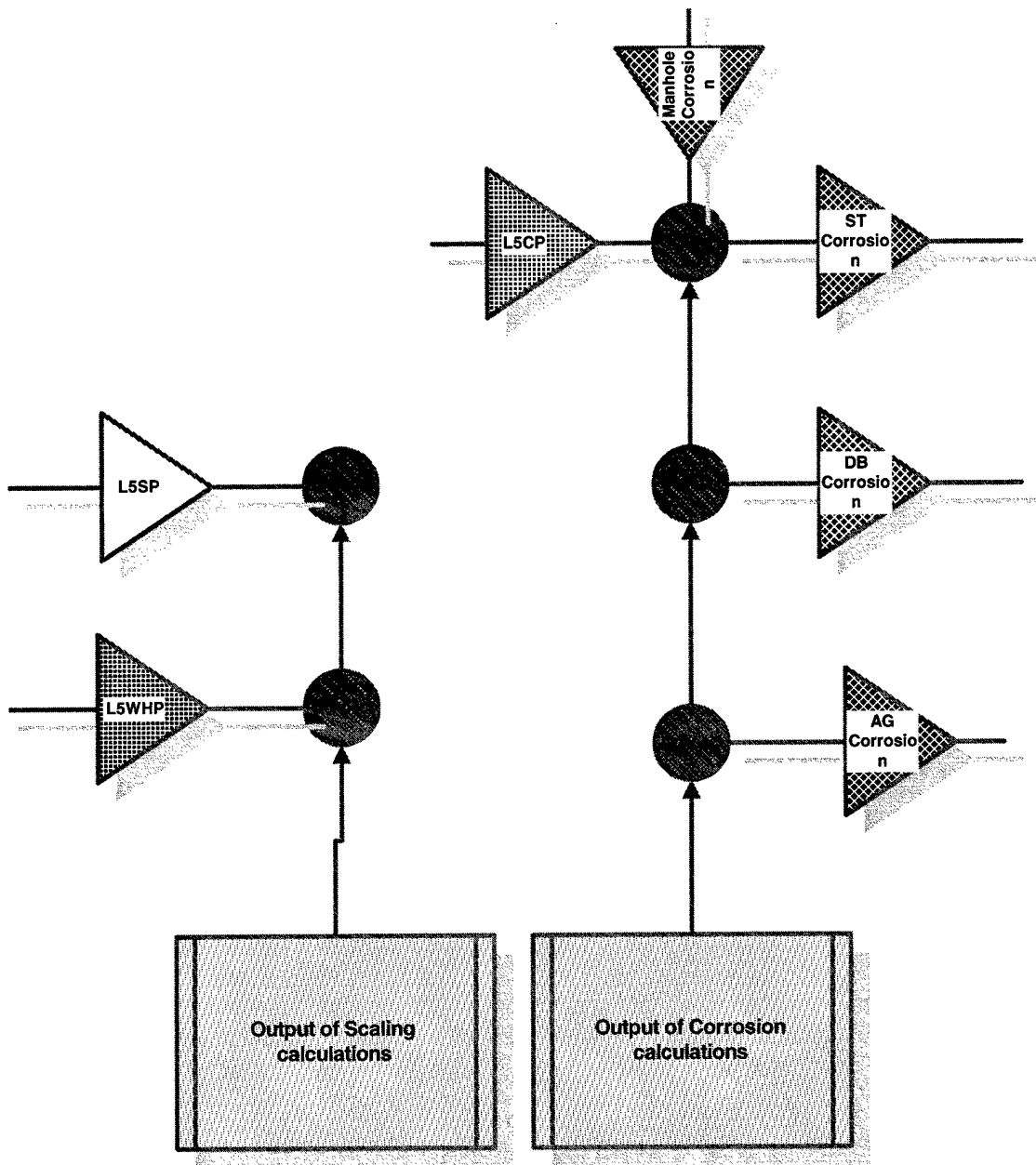

Figure A - 32. Potential causes of carrier pipe internal corrosion or scaling (input to Figure A-25 and others).

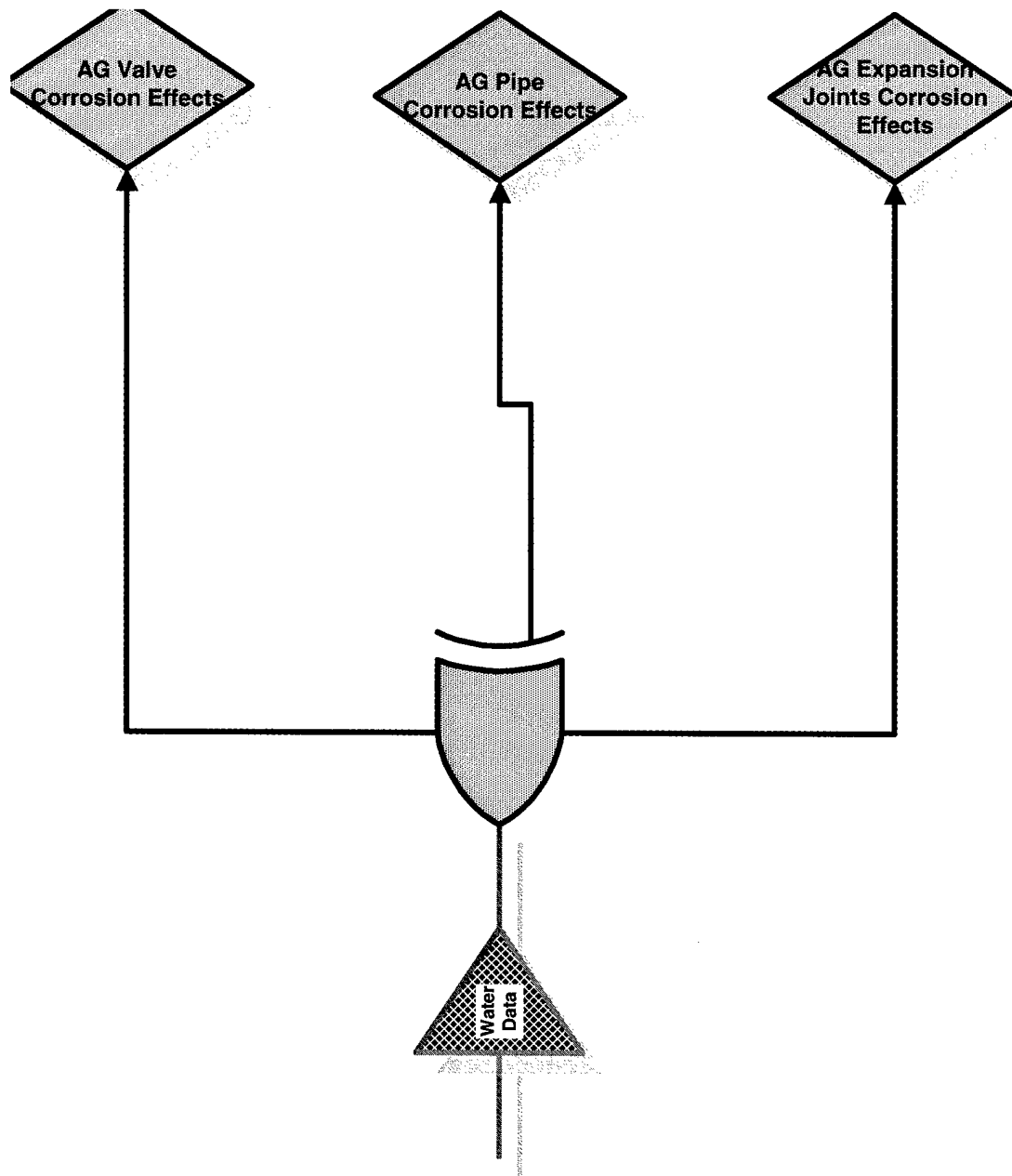

Figure A - 33. Severity of corrosive degradation effects from internal carrier medium leakage based on water data (i.e., water chemistry). These results implicitly feed into Figure A-13.

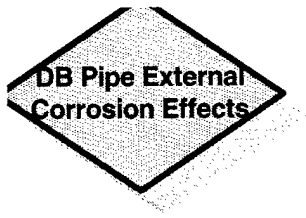

Figure A - 34. Severity of corrosive degradation effects from internal carrier medium leakage based on water chemistry. These results implicitly feed into Figure A-22.

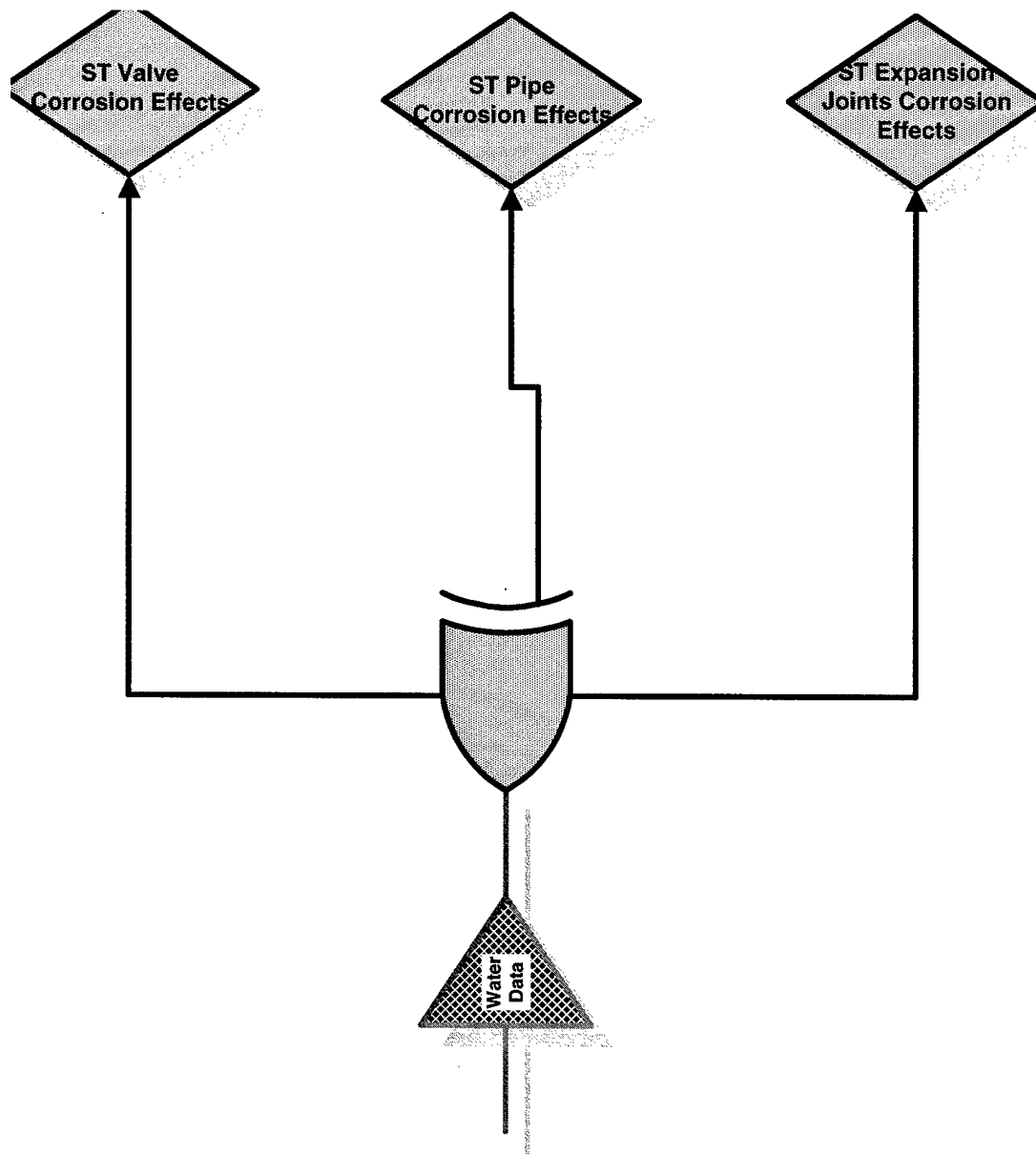

Figure A - 35. Severity of corrosive degradation effects from internal carrier medium leakage based on water chemistry. These results implicitly feed into Figure A-19.

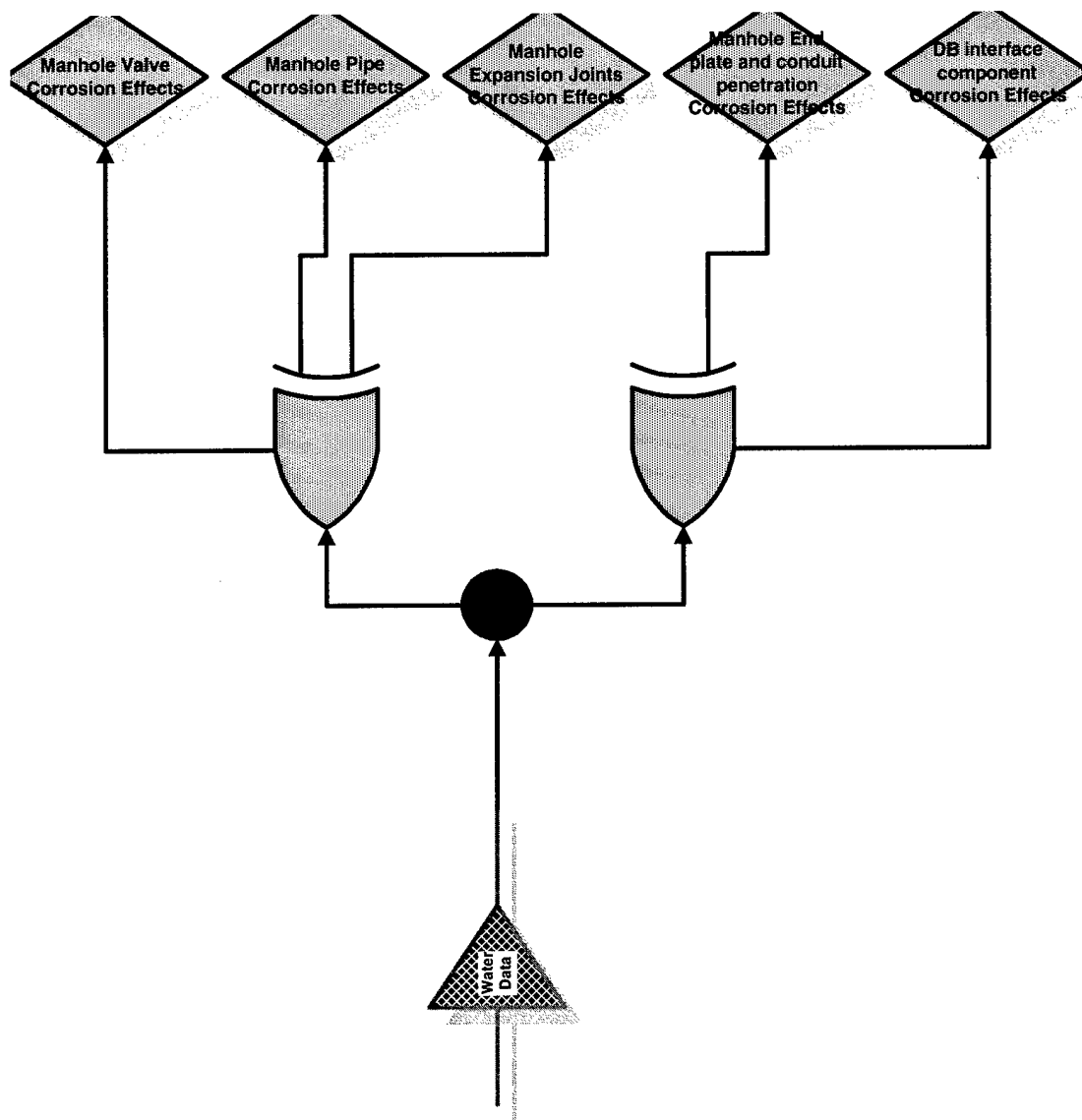

Figure A - 36. Severity of corrosive degradation effects from internal carrier medium leakage based on water chemistry. These results implicitly feed into Figure A-8.

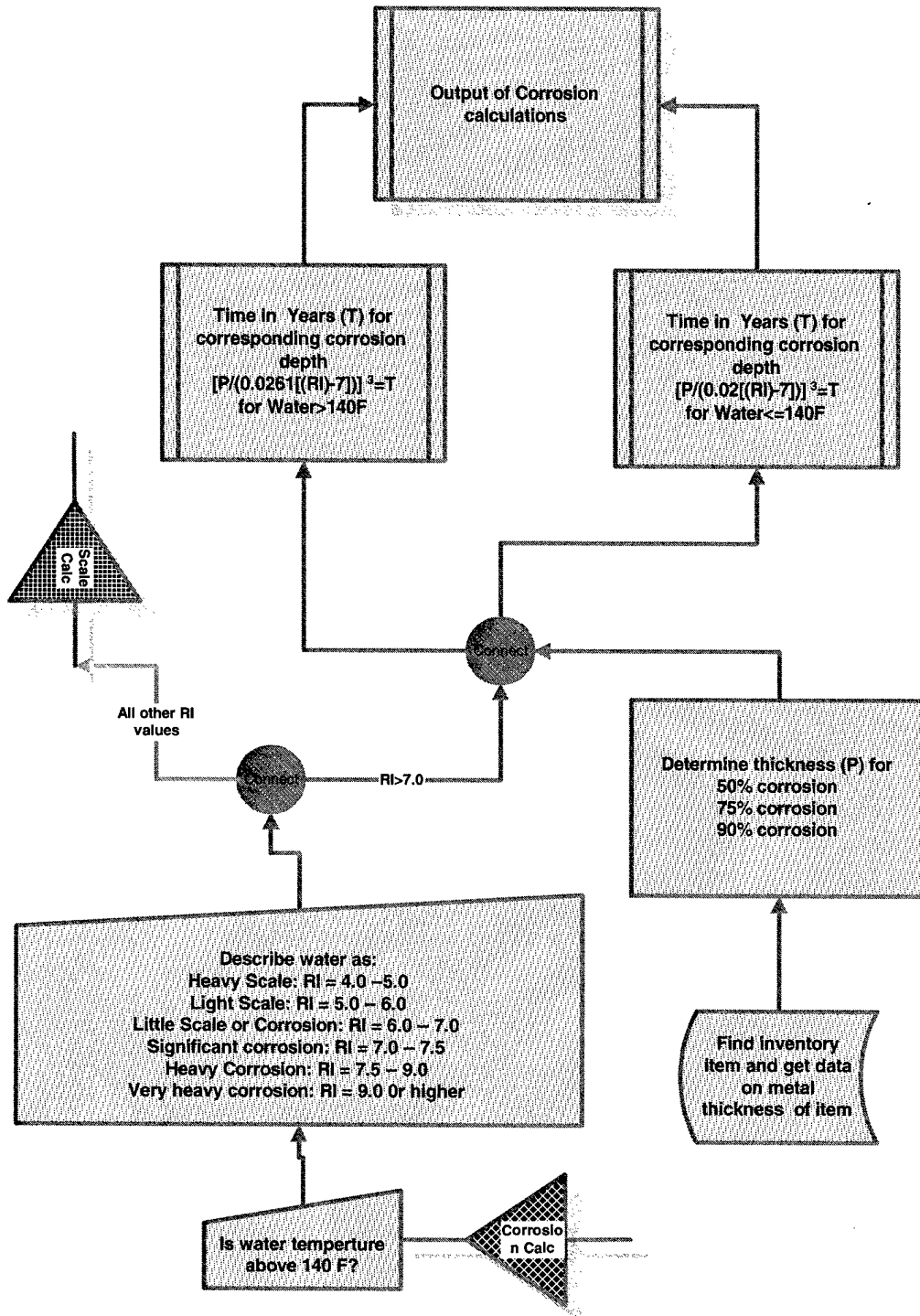

Figure A - 37. Internal carrier pipe corrosion results for input to Figure A-32.

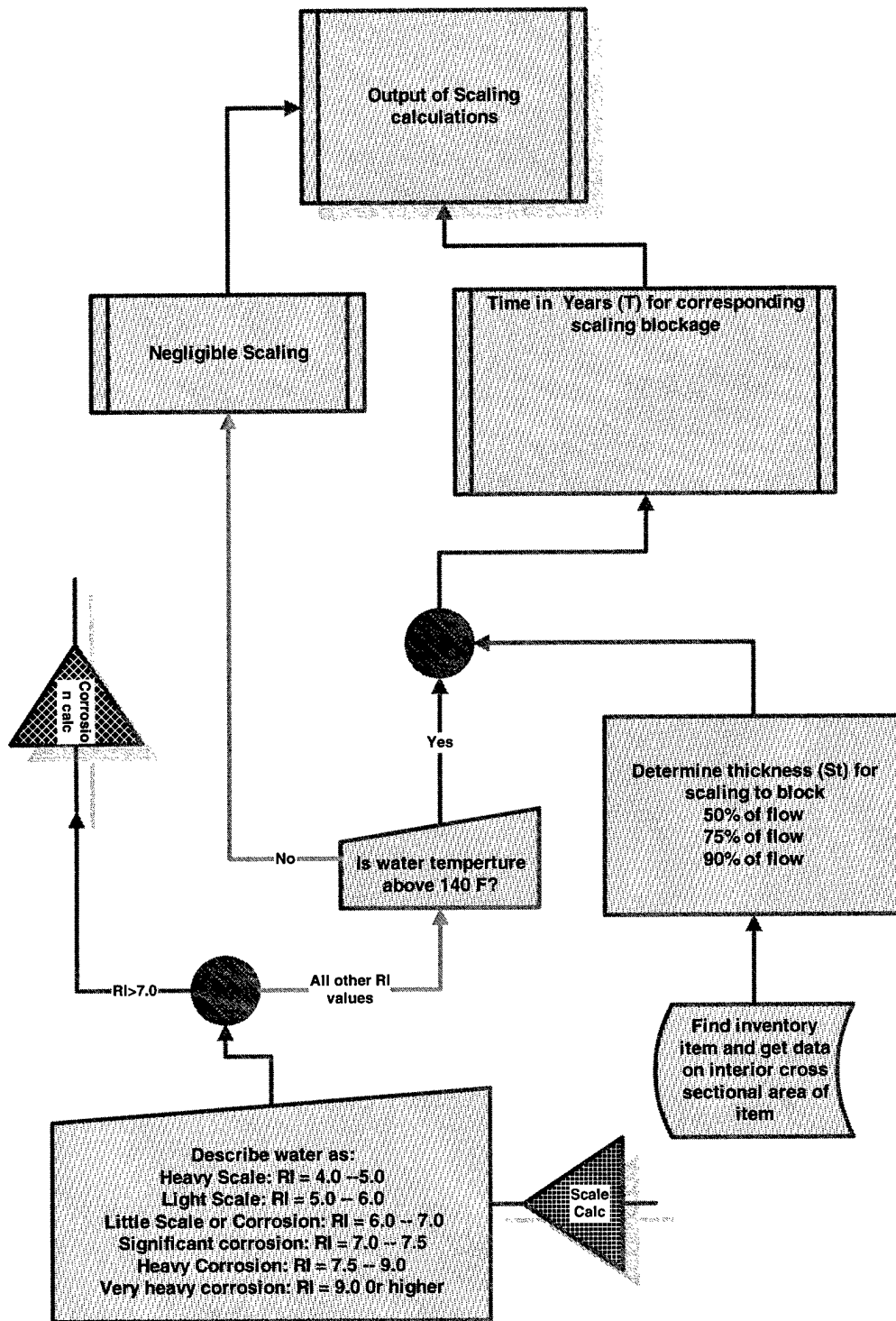

Figure A - 38. Internal carrier pipe scaling results for input to Figure A-32.

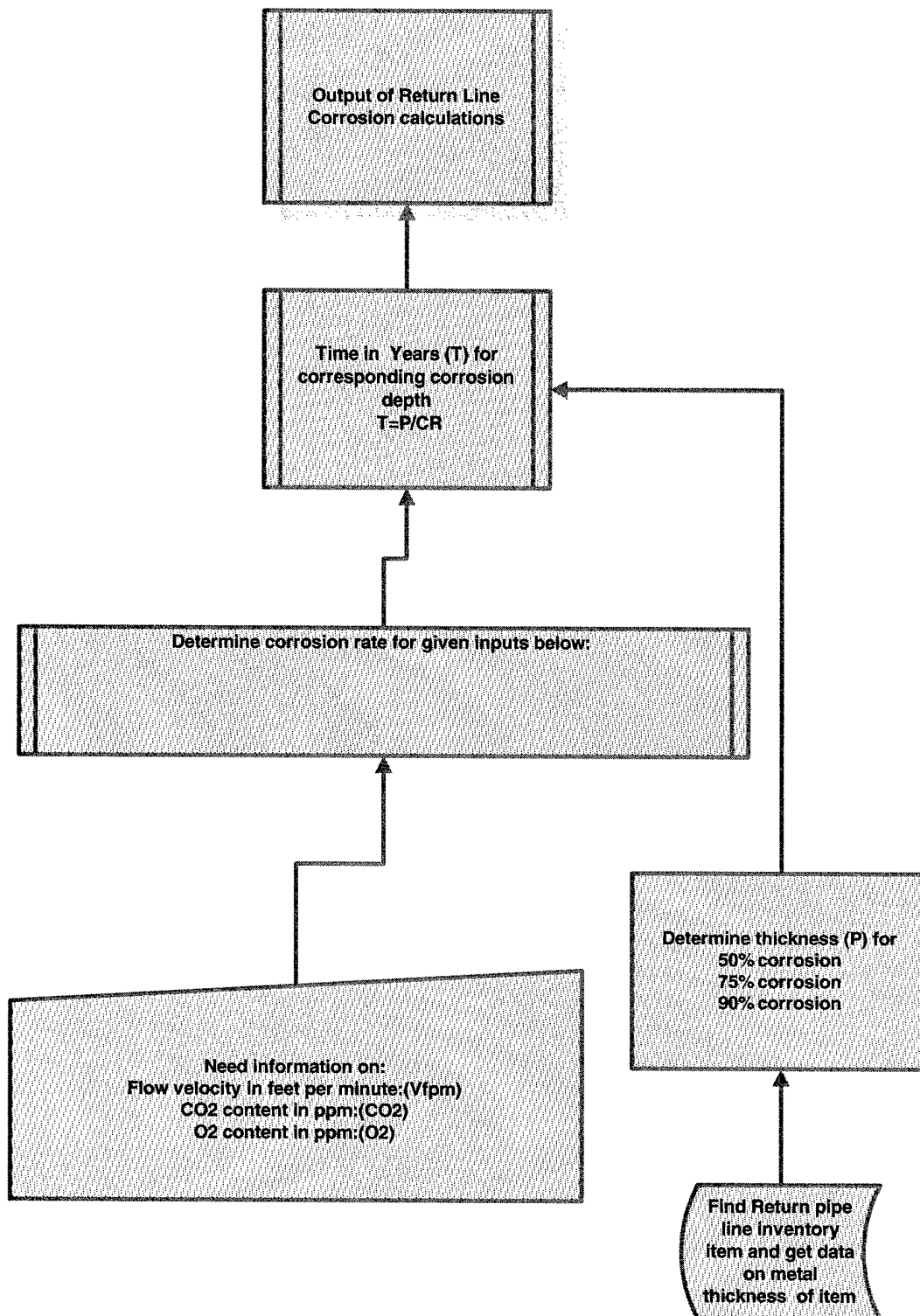

Figure A - 39. Severity of soil side corrosive degradation effects on direct buried conduits. These results implicitly feed into Figure A-24.

Appendix B: CI Tree

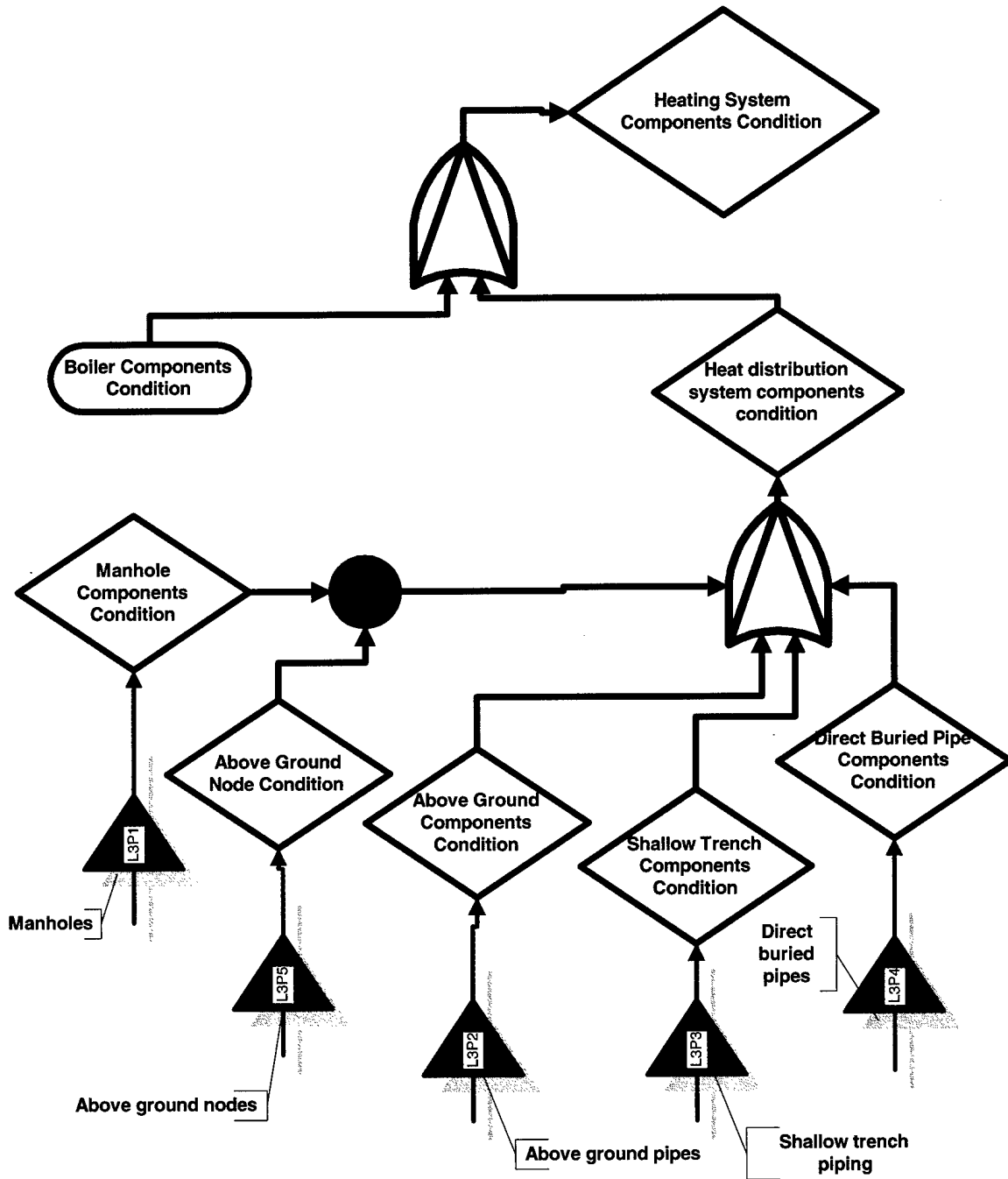

Figure B - 1. Overall Condition index (CI) tree for heat distribution systems.

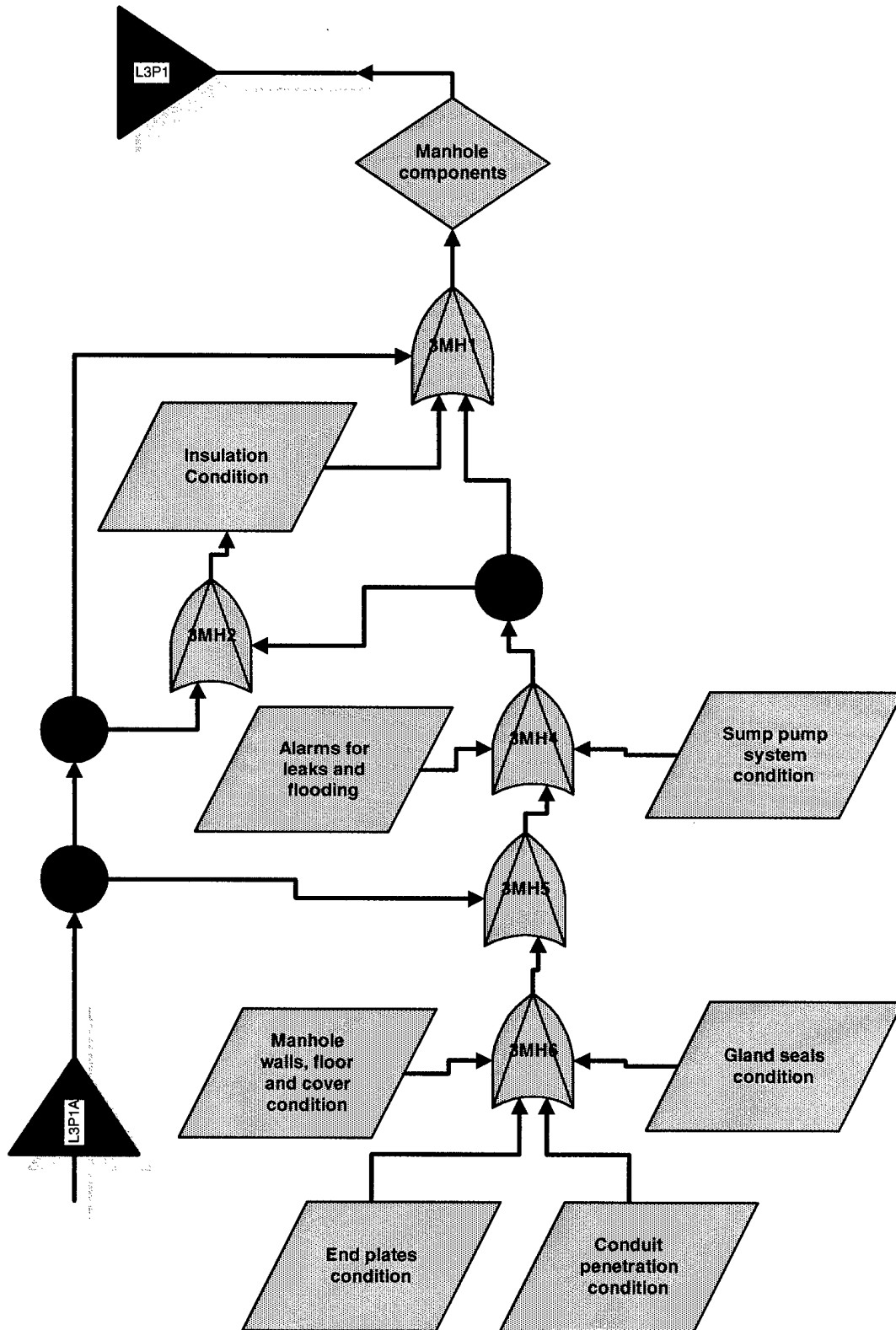

Figure B - 2. Manhole (node) component condition.

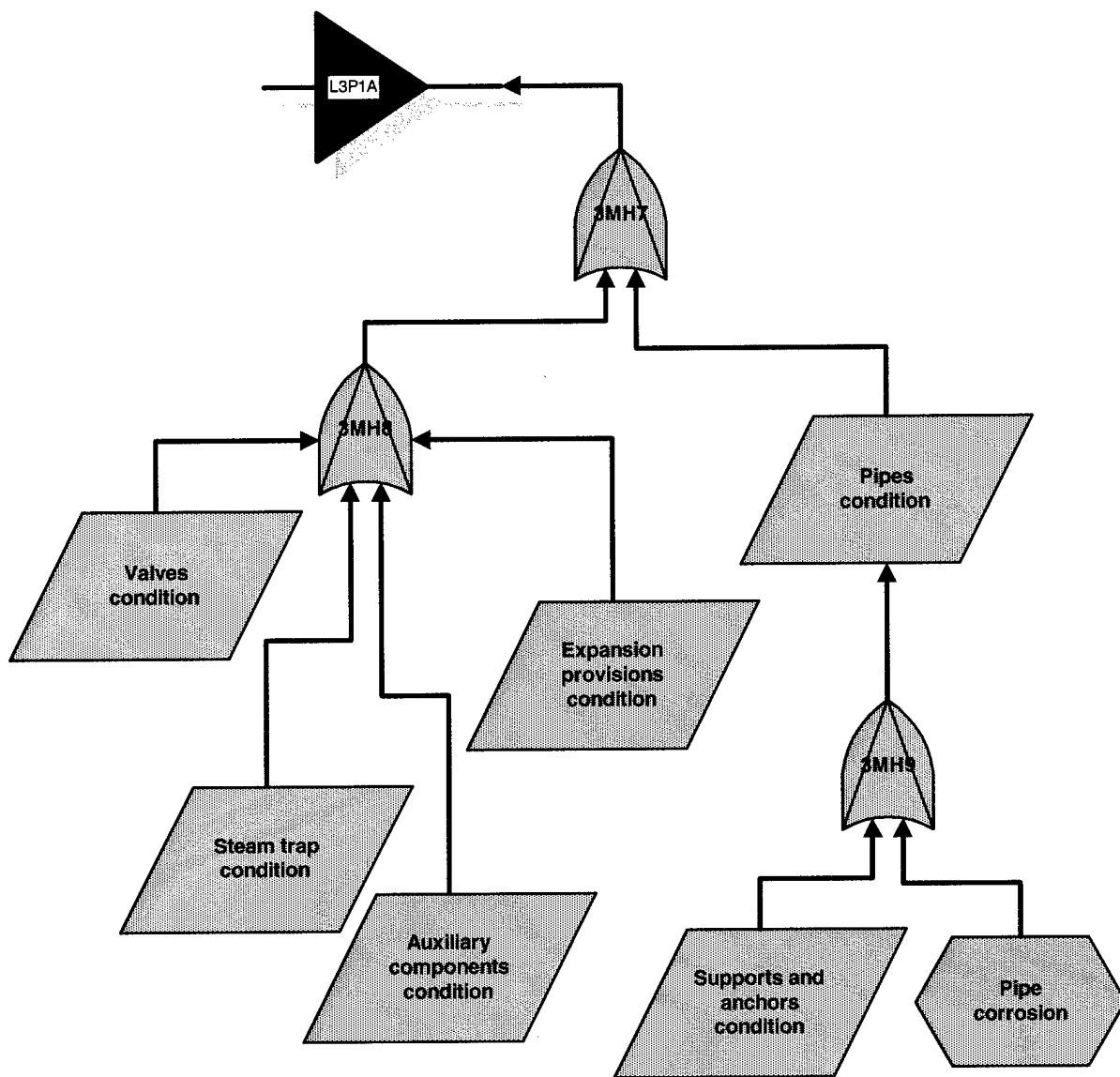

Figure B - 3. Input for manhole (node) component condition shown in Figure B-2.

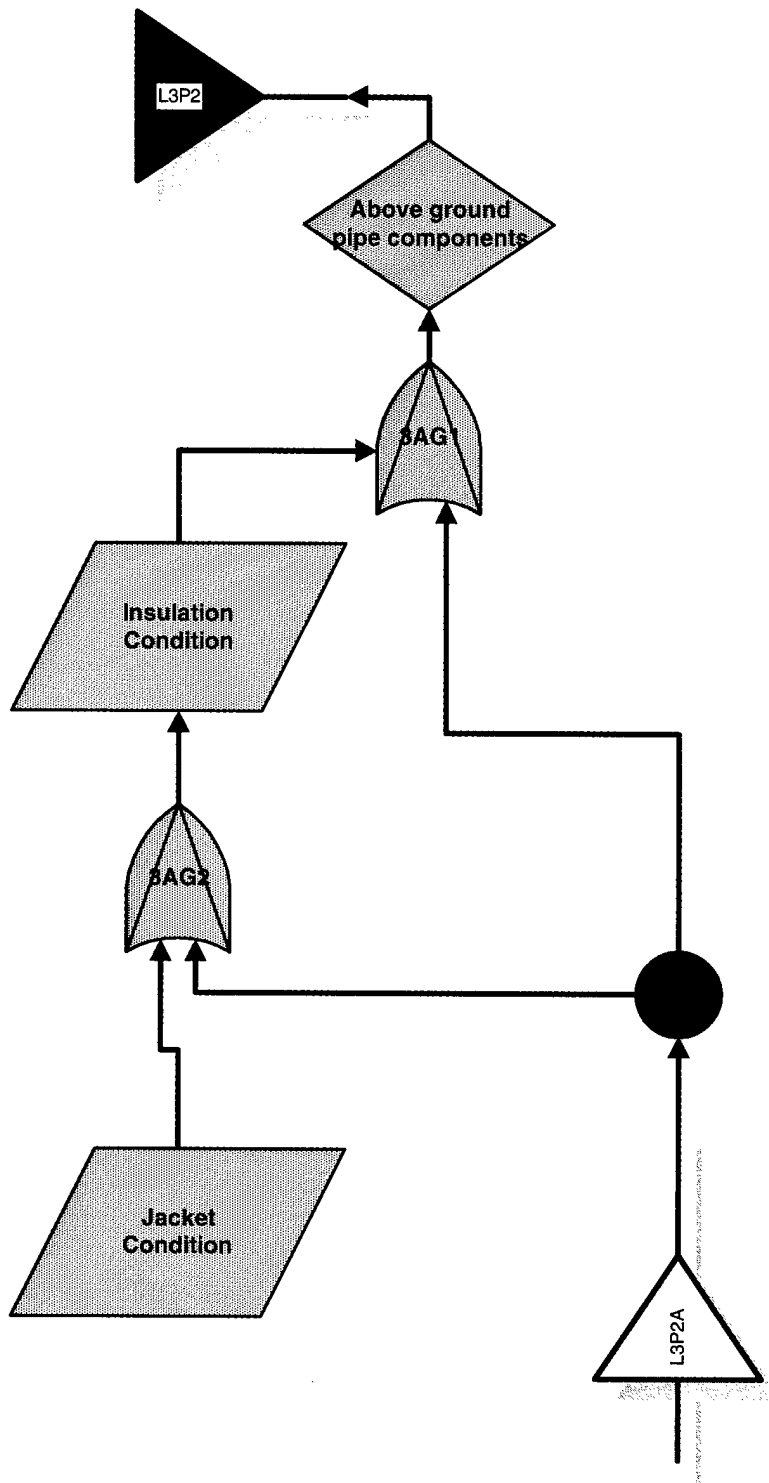

Figure B - 4. Aboveground node component condition.

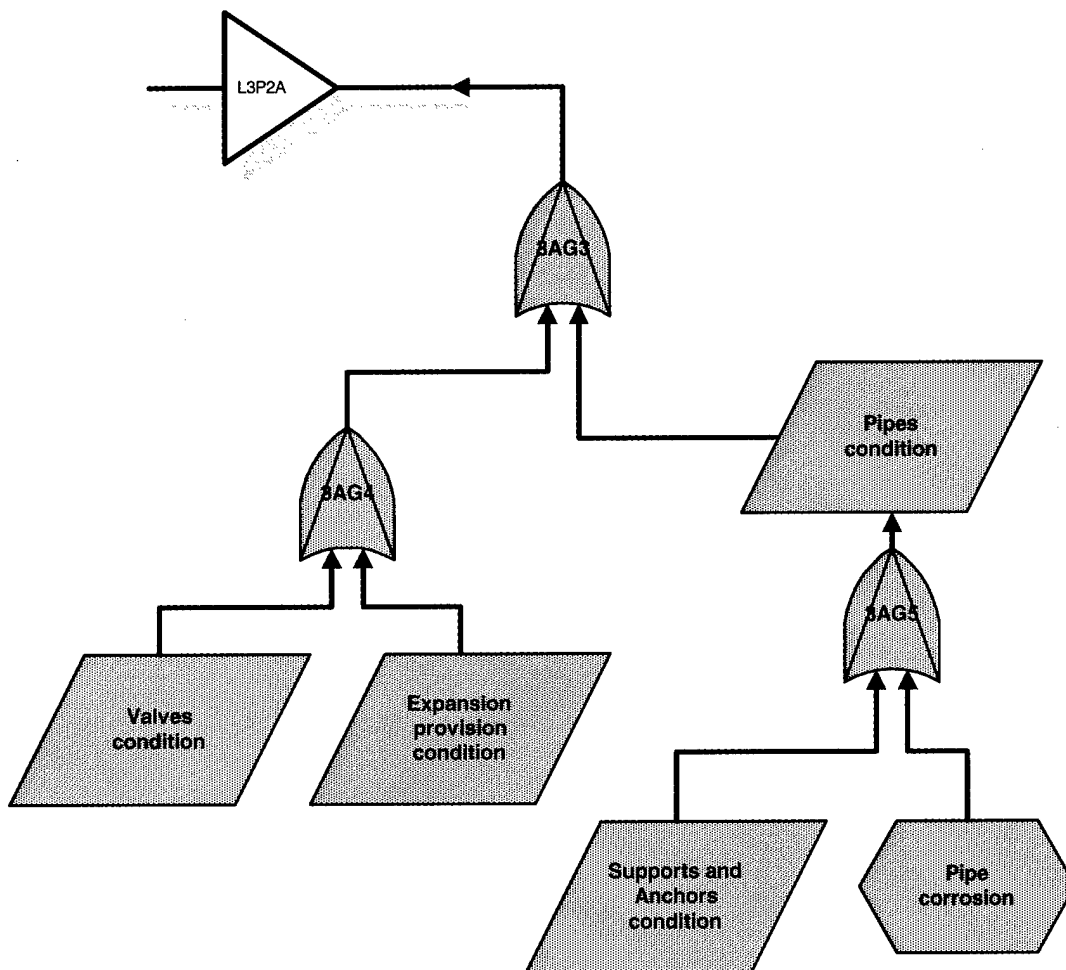

Figure B - 5. Input for aboveground node component condition shown in Figure B-4.

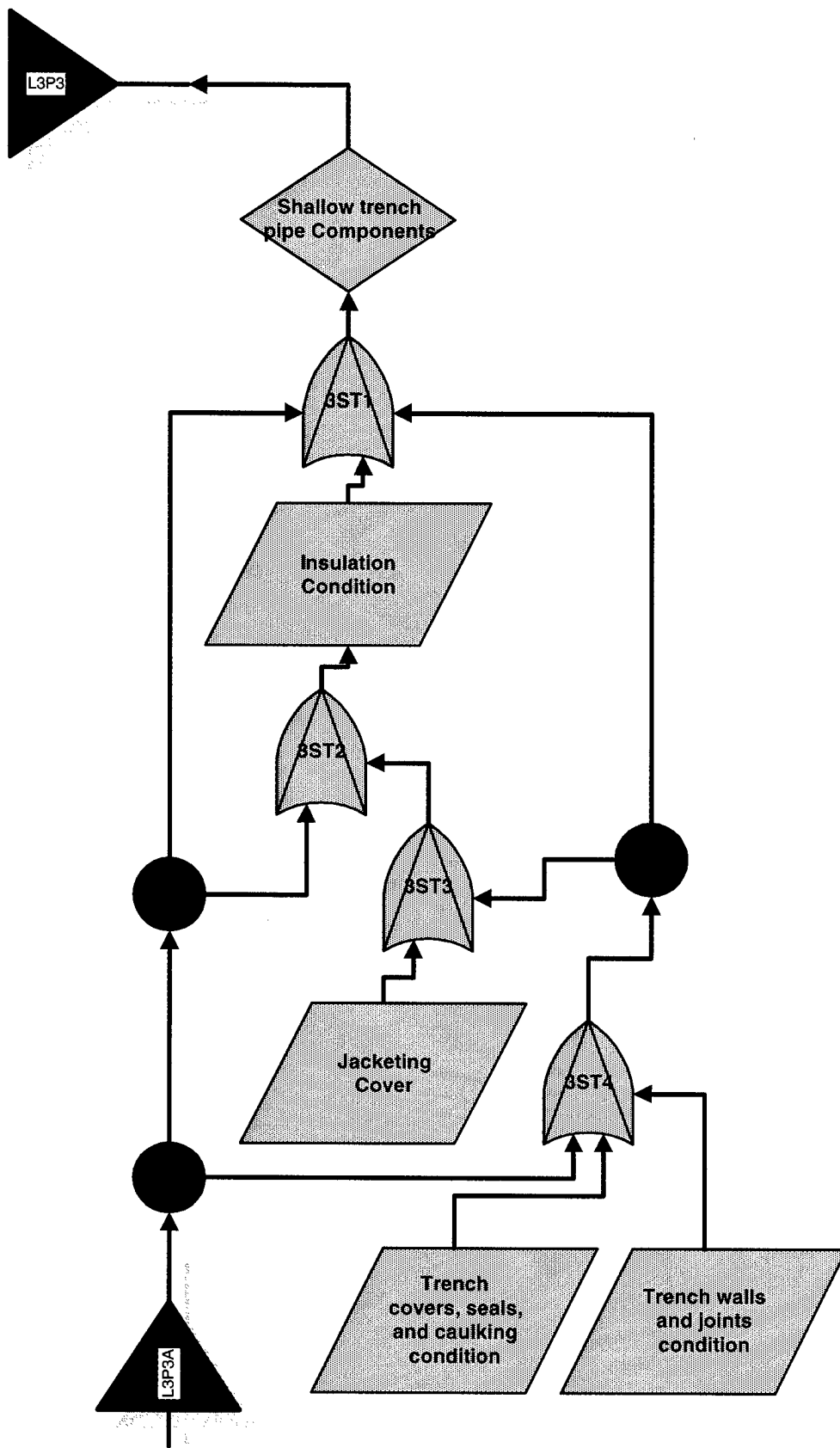

Figure B - 6. Shallow trench segment component condition.

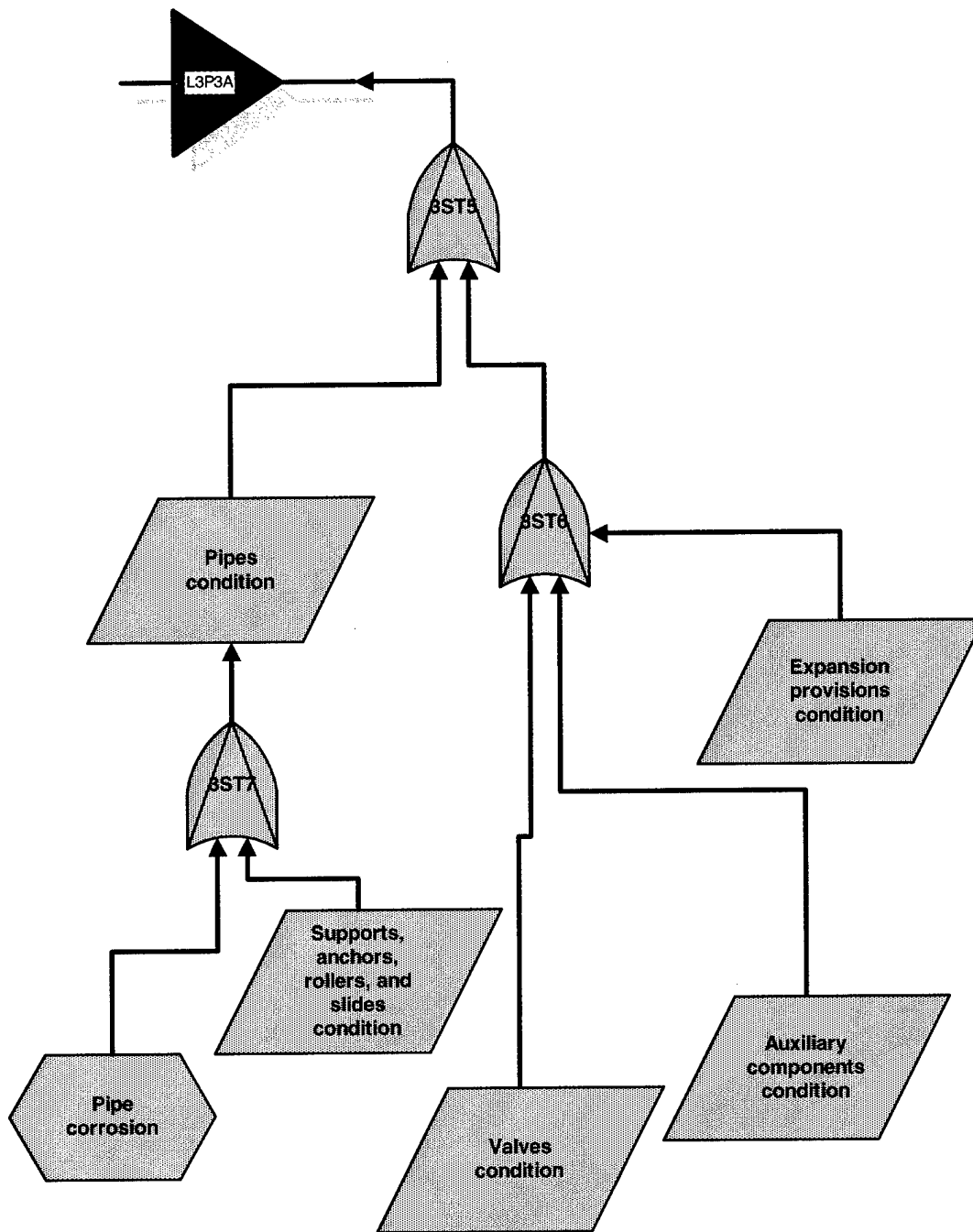

Figure B - 7. Input for shallow trench segment component condition shown in Figure B-6.

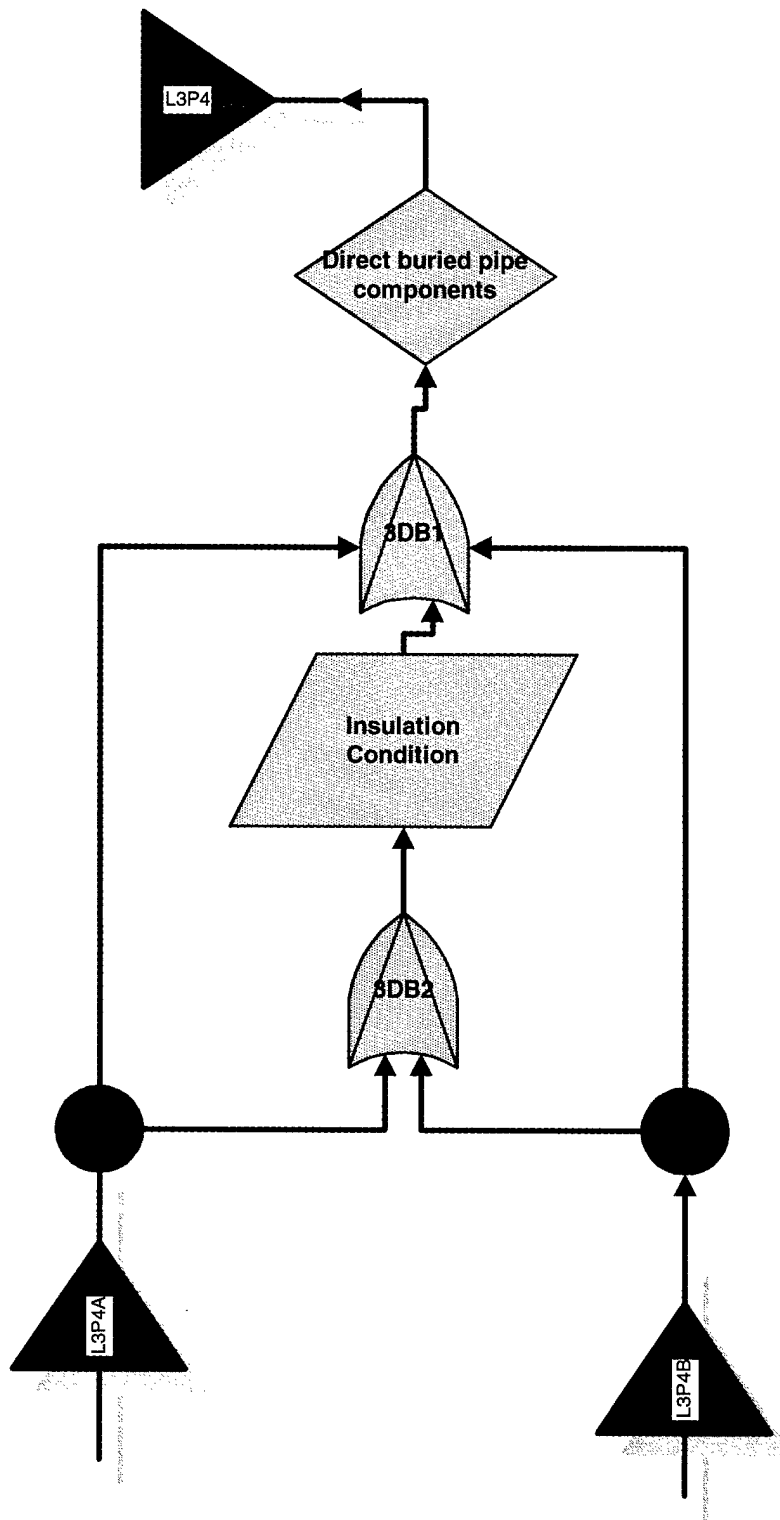

Figure B - 8. Direct buried segment component condition.

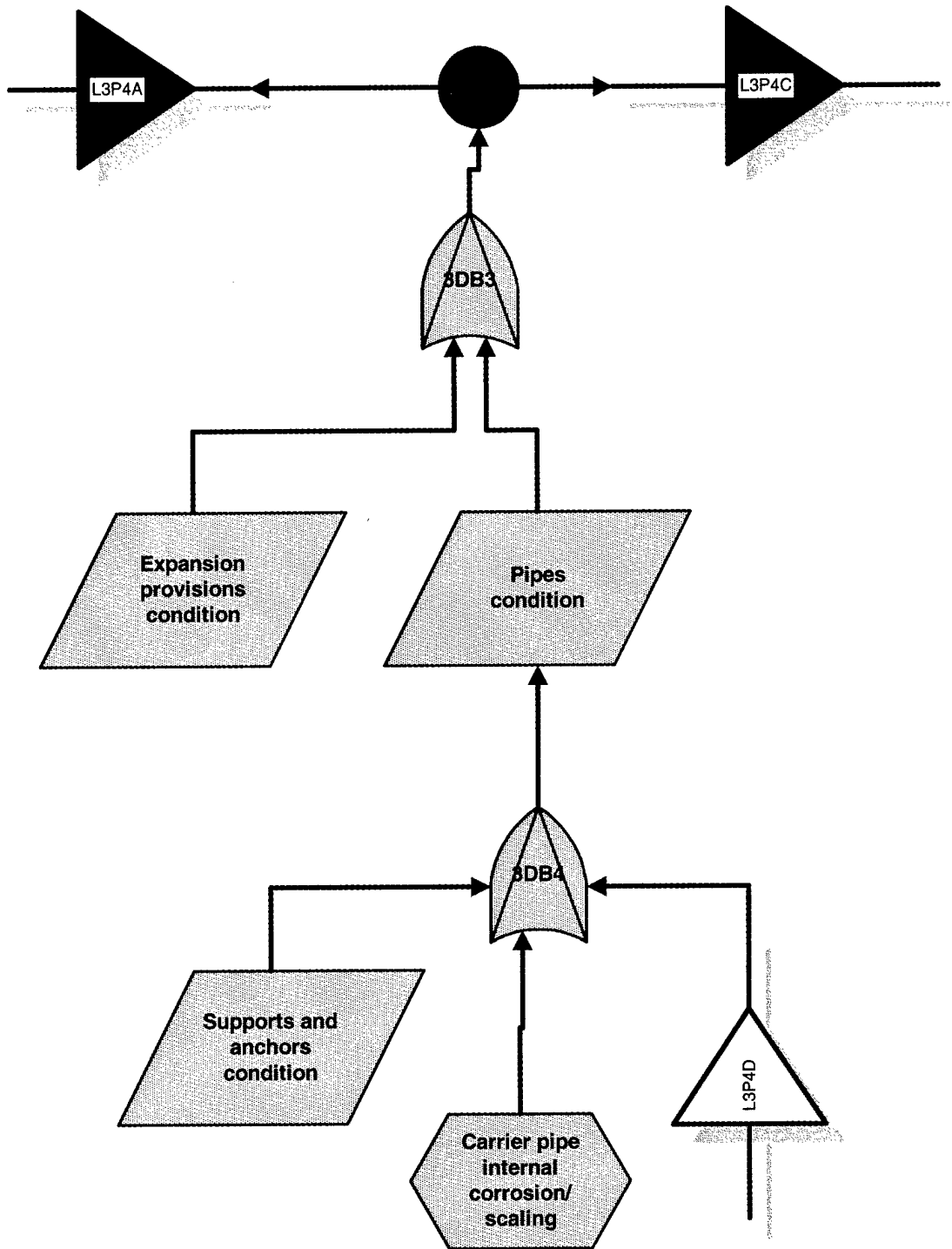

Figure B - 9. Input (L3P4A) for direct buried segment component condition shown in Figure B-8.

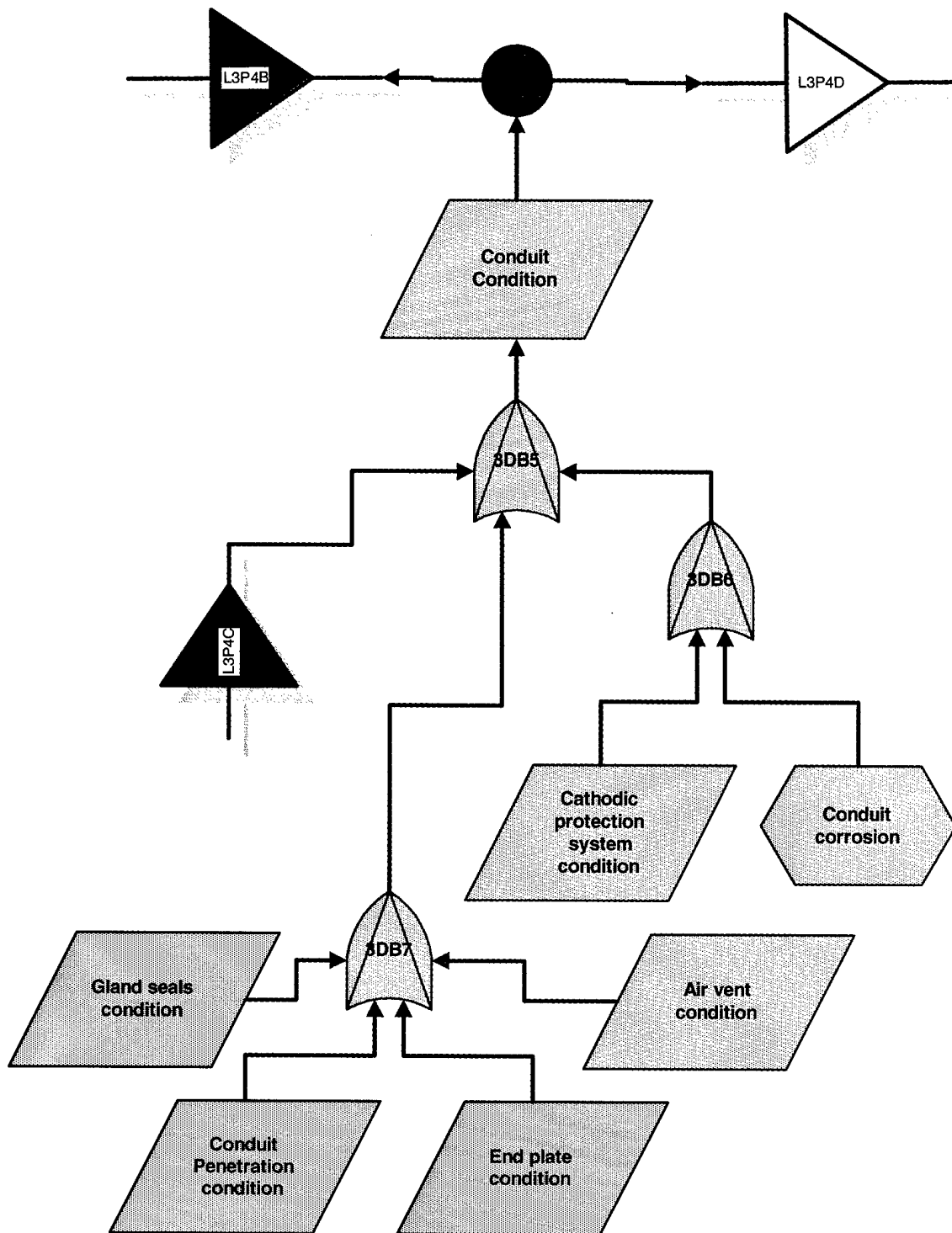

Figure B - 10. Input (L3P4B) for direct buried segment component condition shown in Figure B-8. Note potential interactions of (1) carrier pipe condition affecting the conduit (L3P4C), and (2) conduit pipe condition affecting the carrier (L3P4D). Also note, in pink, the potential effect of specific manhole components on conduit condition.

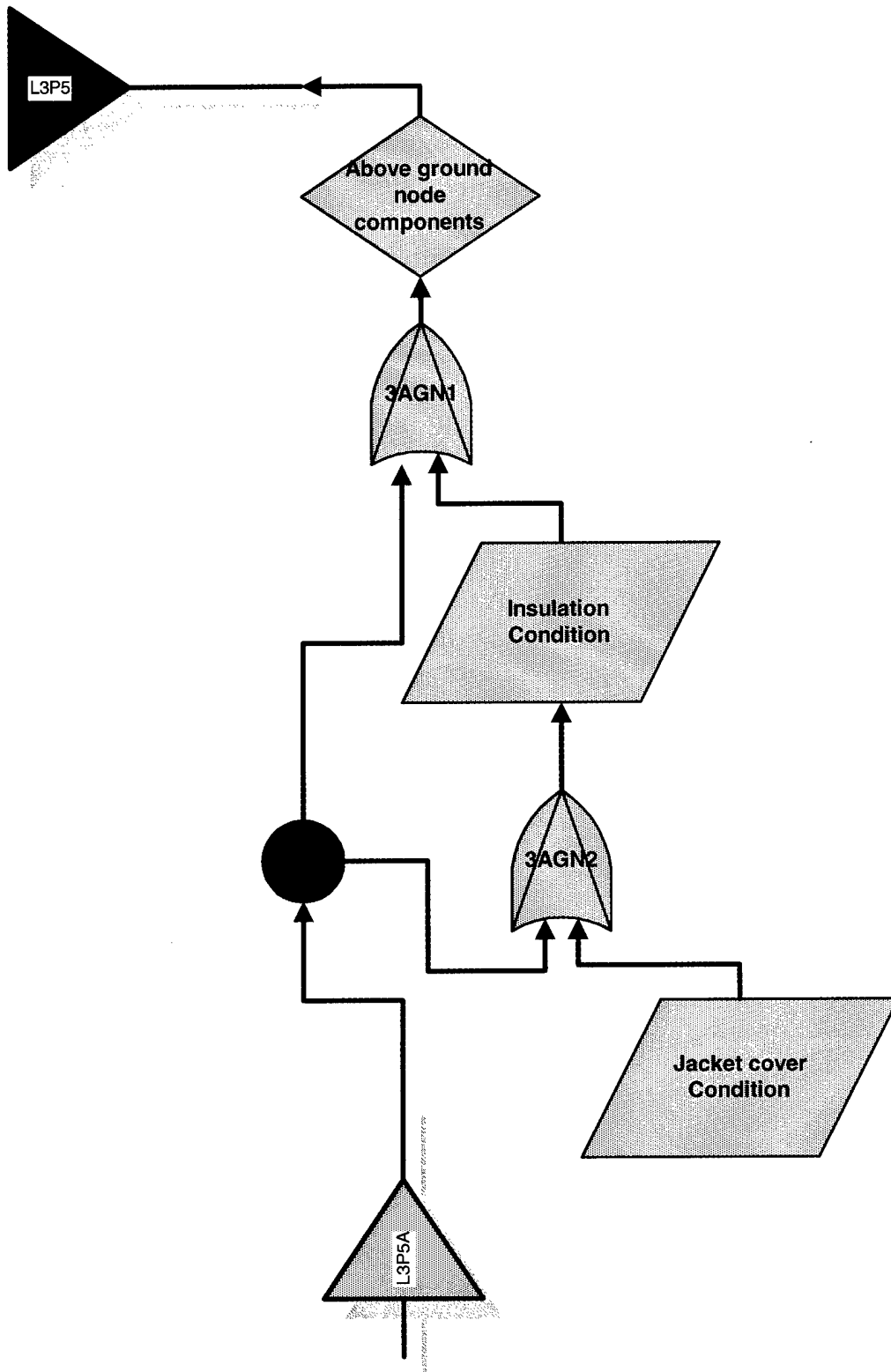

Figure B - 11. Aboveground node component condition.

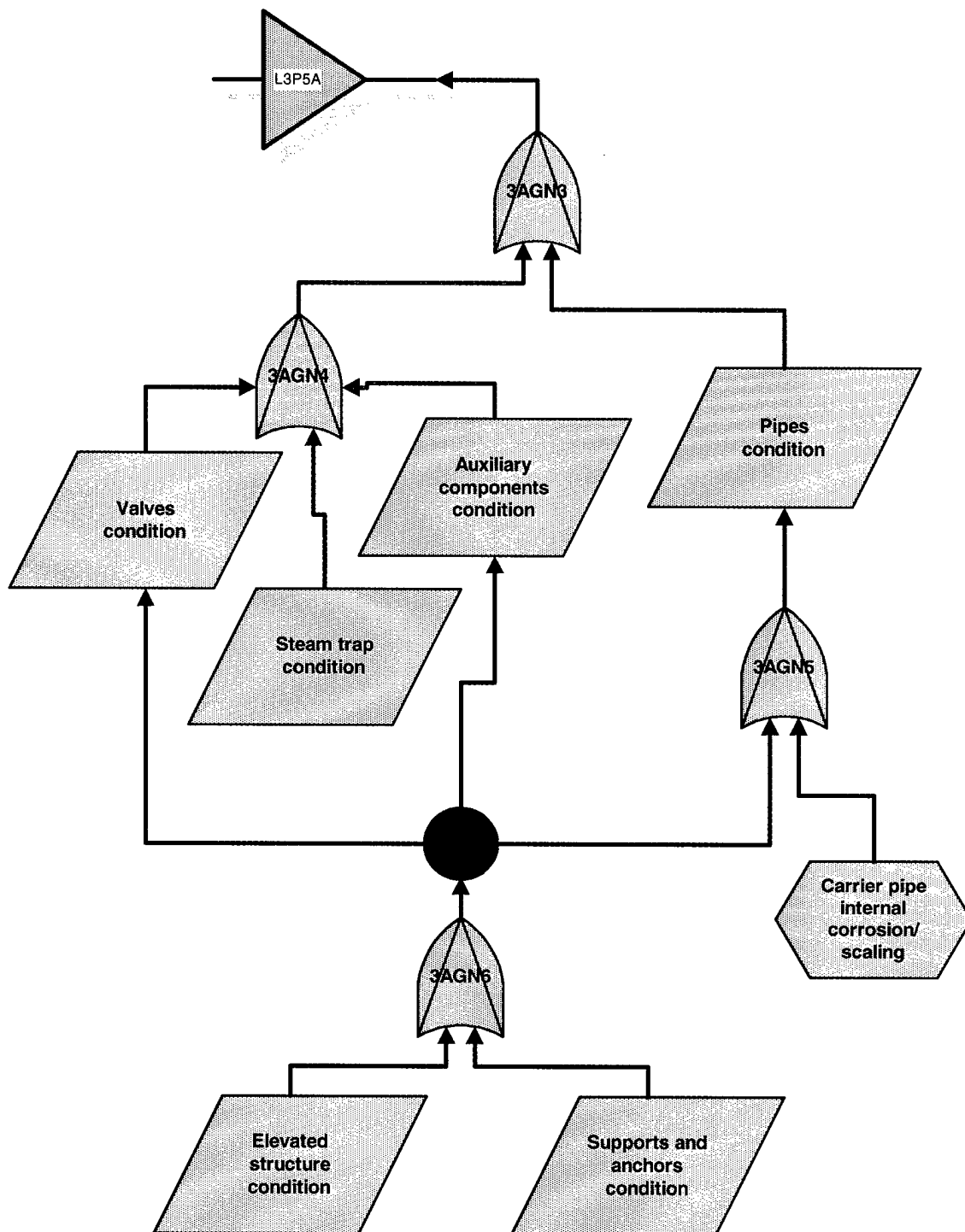

Figure B - 12. Input for aboveground component condition shown in Figure B-11.

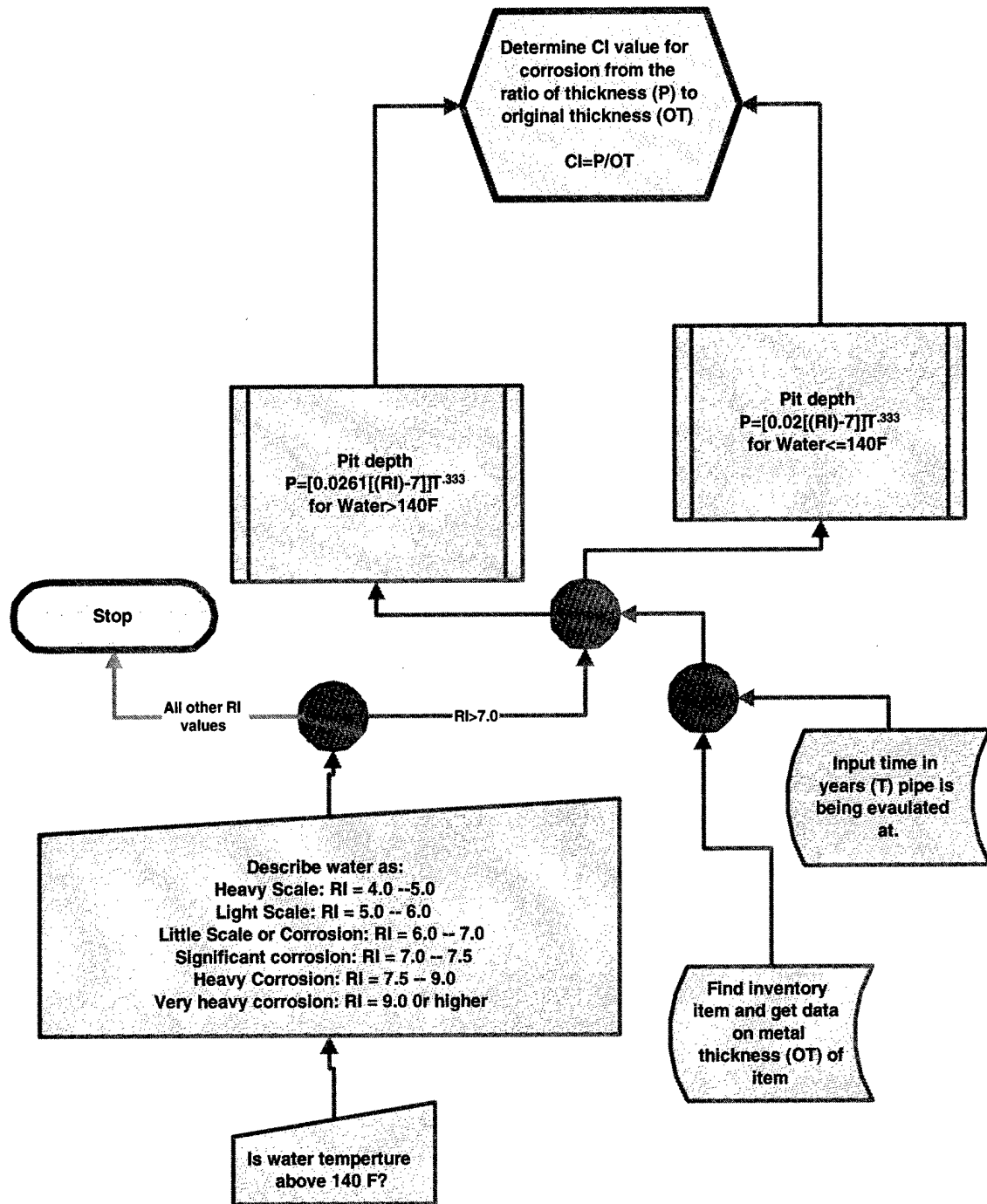

Figure B - 13. Input for "carrier pipe internal corrosion/scaling" shown in Figures B-5, B-7, B-9, and B-12.

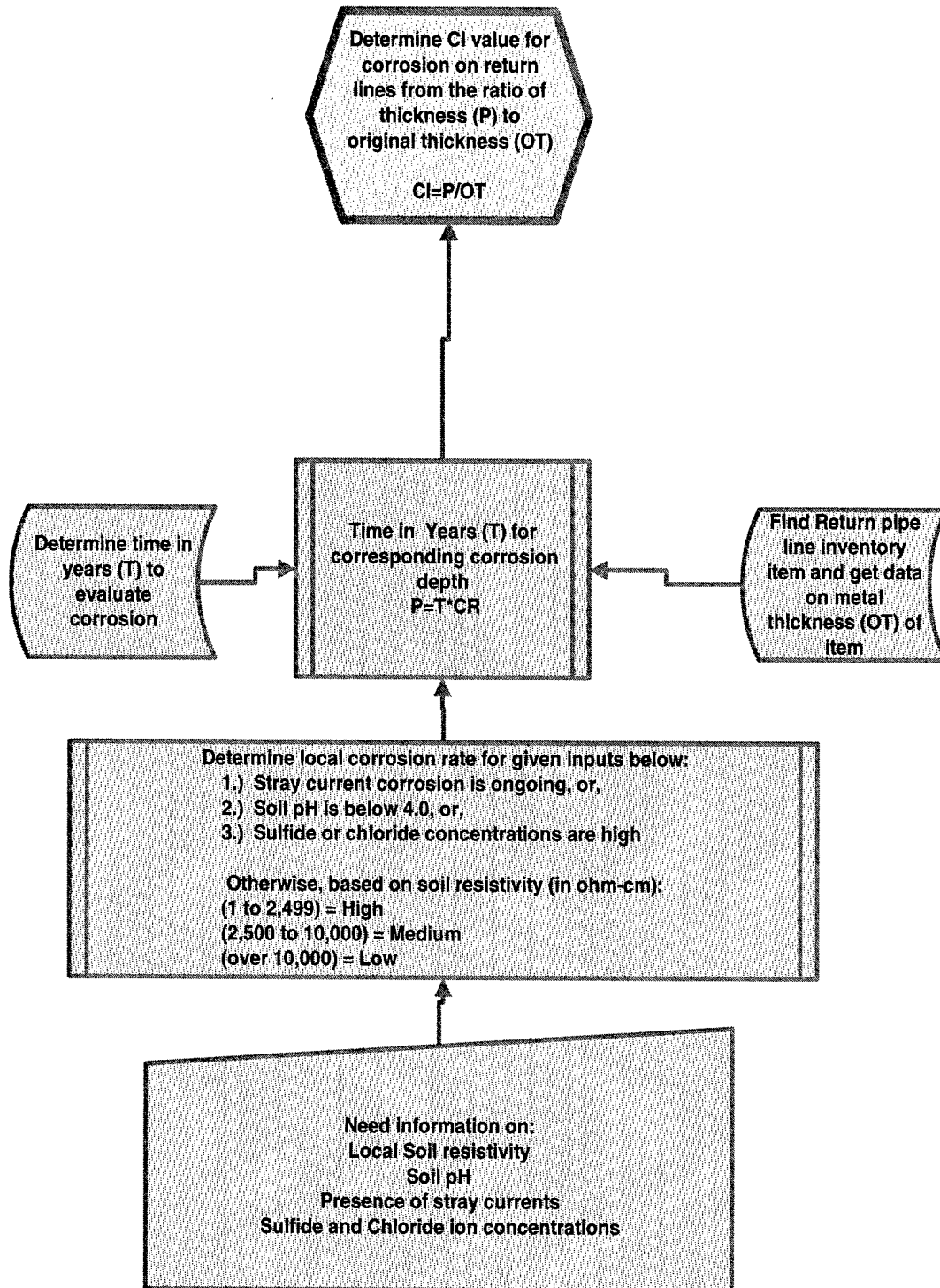
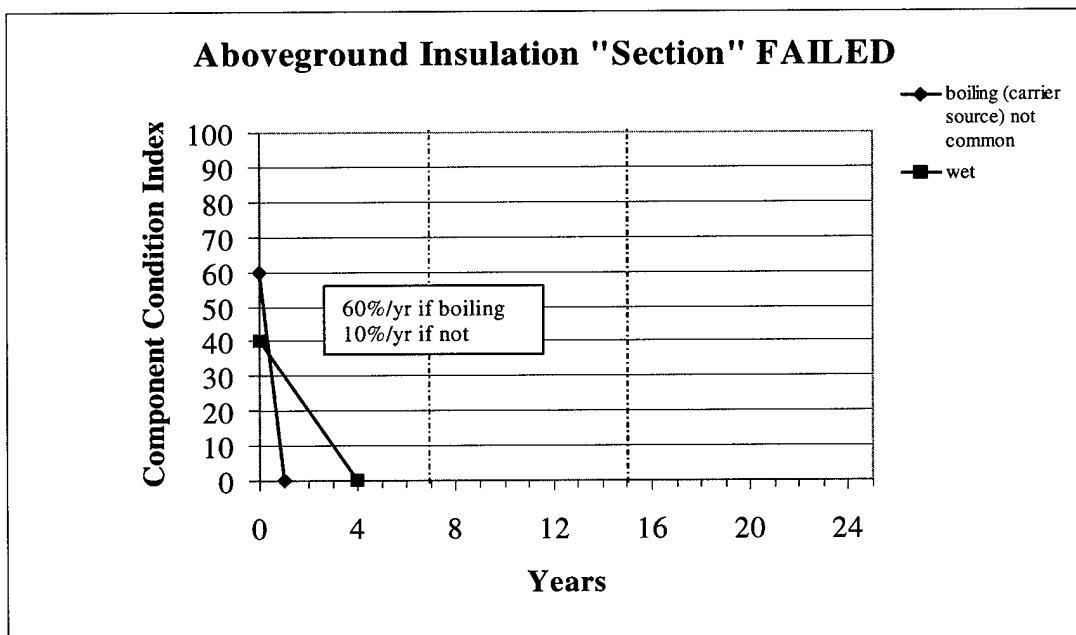
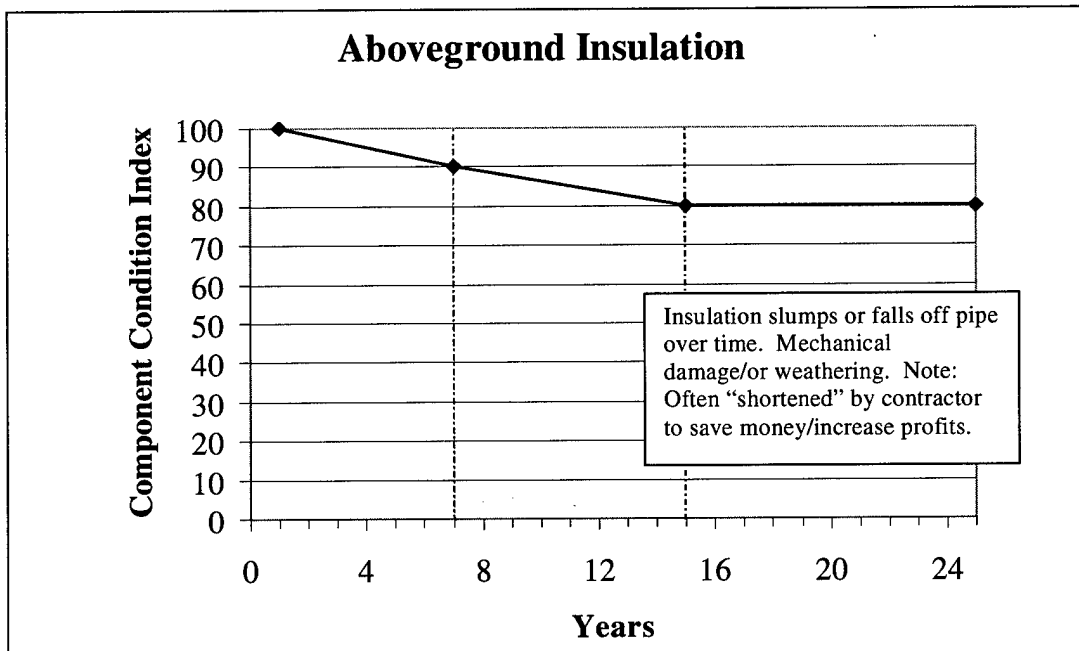
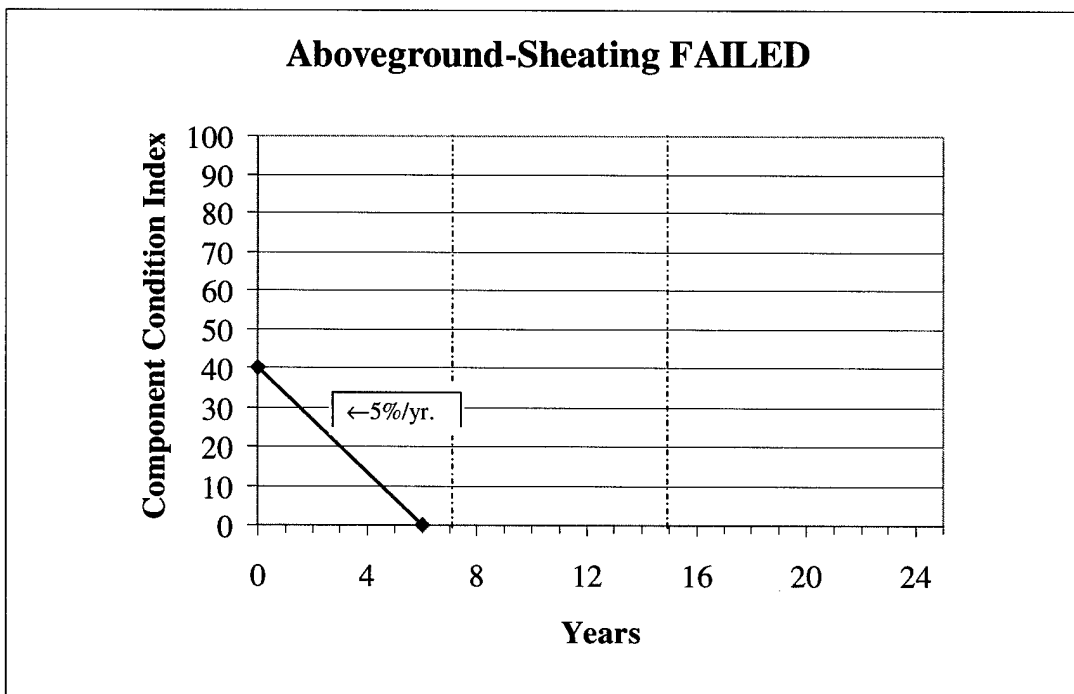
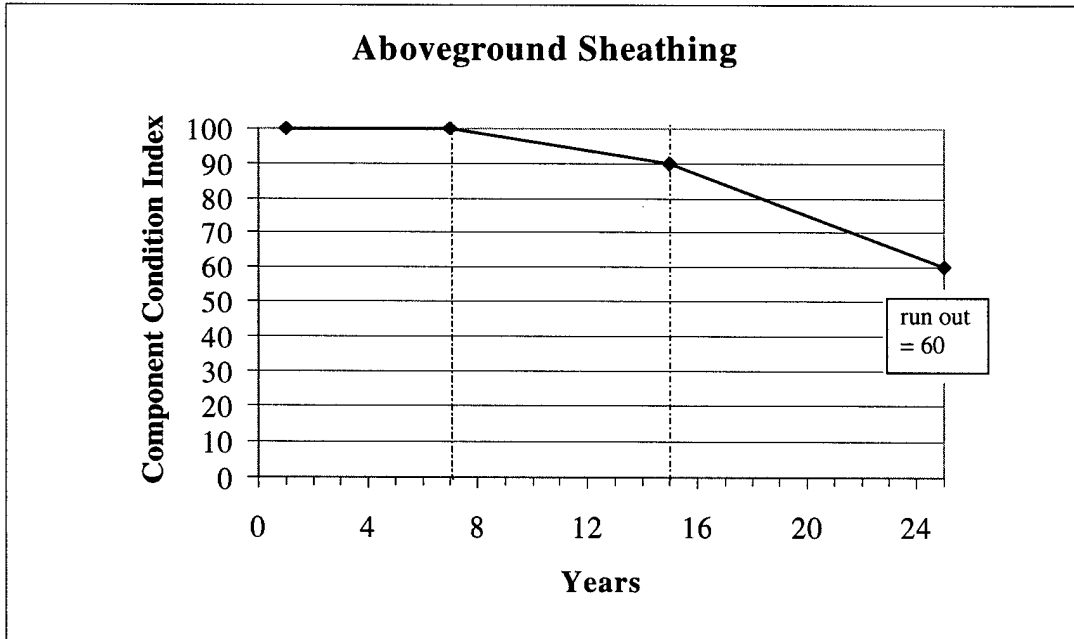

Figure B - 14. Input for "external conduit corrosion" shown in Figure B-10.

Appendix C: Individual Component Graphs



t=0 at failure
 -water intrusion (or from carrier)
 -wetting degrades [a. insulating ability b. mechanical strength]
 -boiling water destroys completely and quickly



(condition of sheathing only)

t=0 at failure; letting water in

-mechanical impact damage

-low profile: walked on

-rare: chlorides in insulation causing accelerated sheathing corrosion

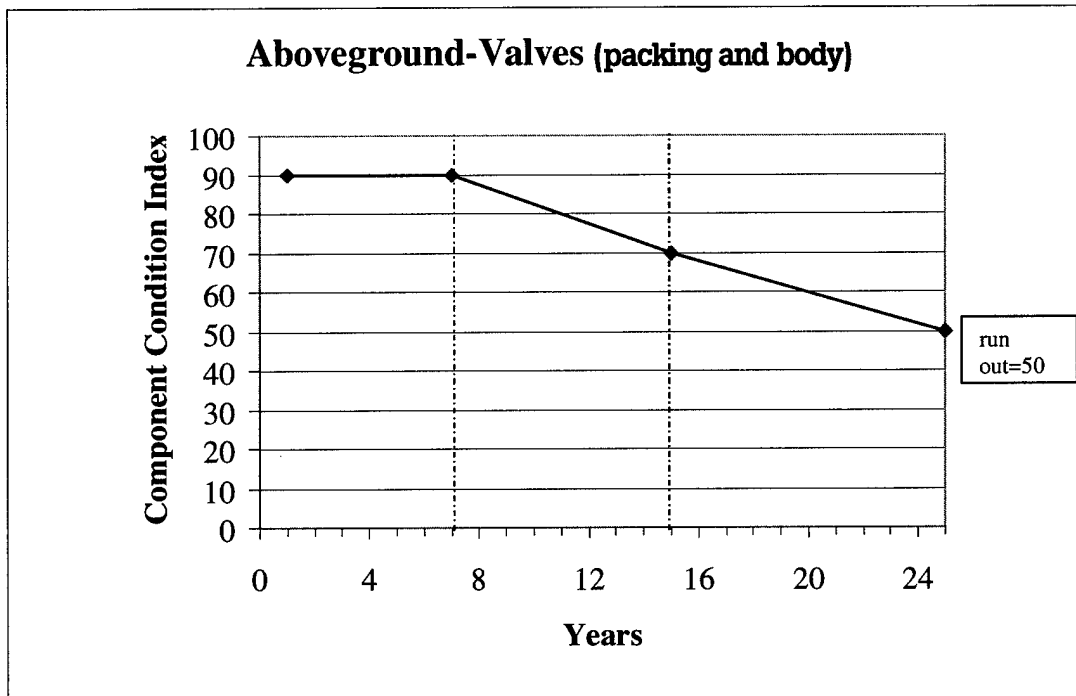

Note: Failure of valve body is very rare.

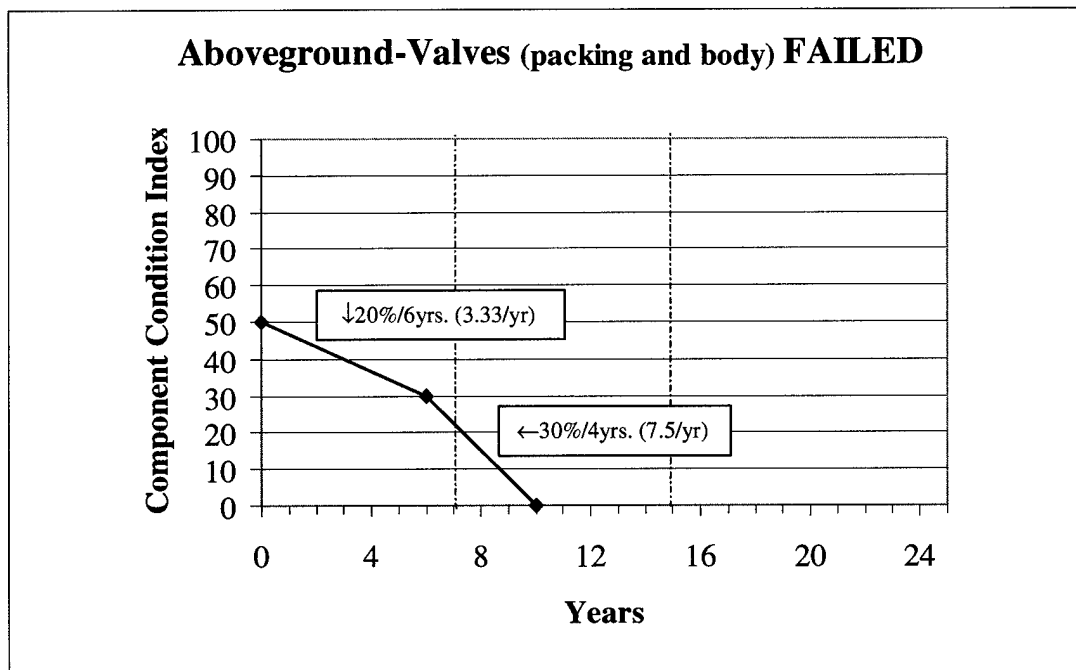

t=0 at failure

-packing leak leading to corrosion

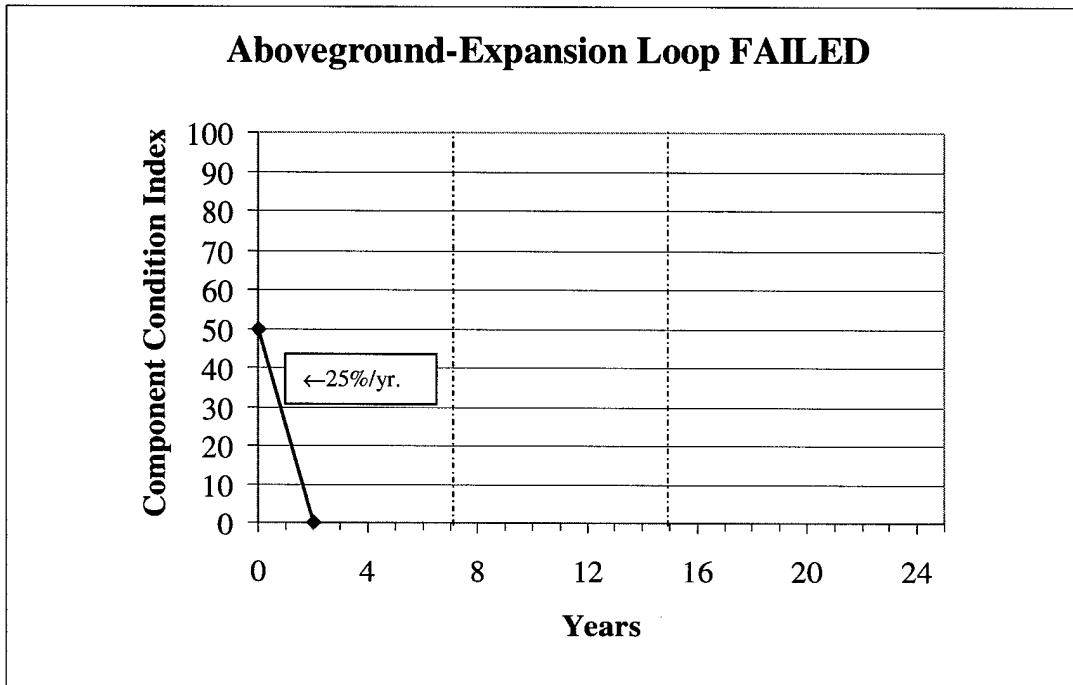
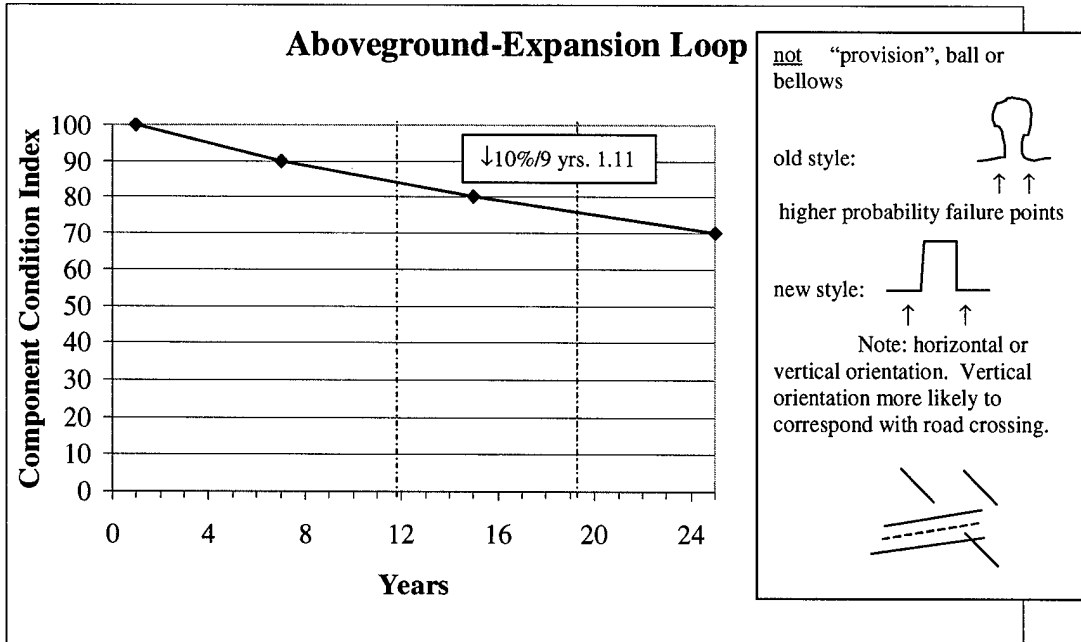

t=0 at failure

Note: For carrier leak from fatigue and/or mold failure (mitered elbows wpecially bad)

Note: A leak under pressure will get worse fairly quickly (and also wet insulation)

Note: Typically start as a trickle.

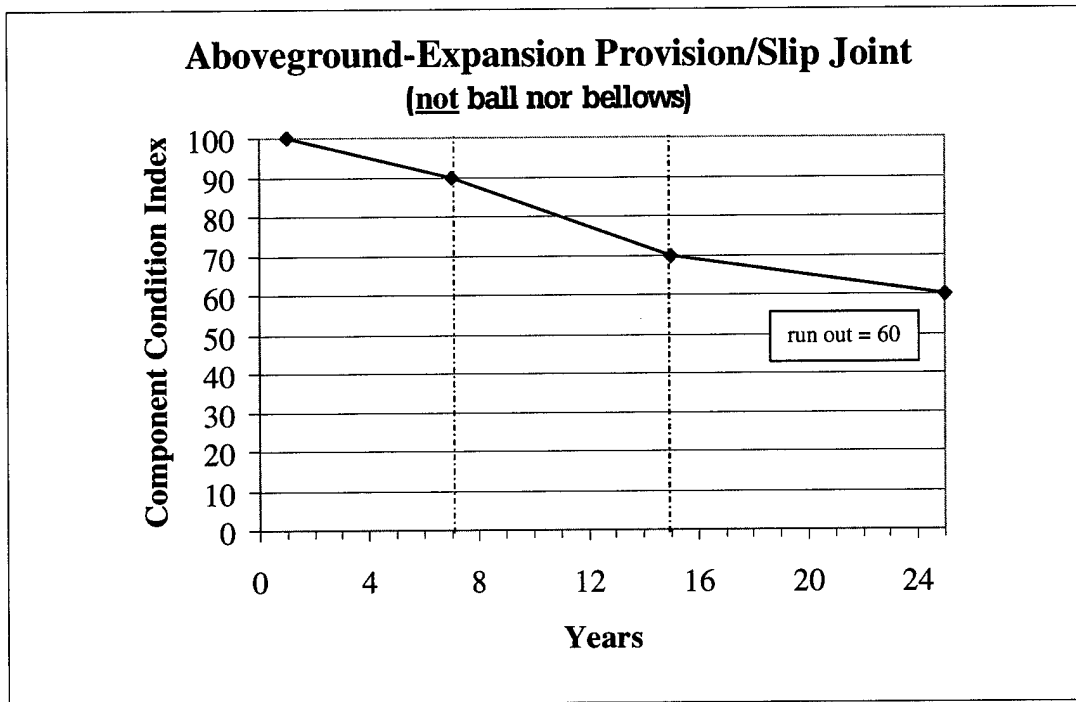

Typically not maintained (lubricated).

Somewhat prone to initial problems-design [length of travel] and installation [alignment]

Can also be a problem when not considered when changing the system

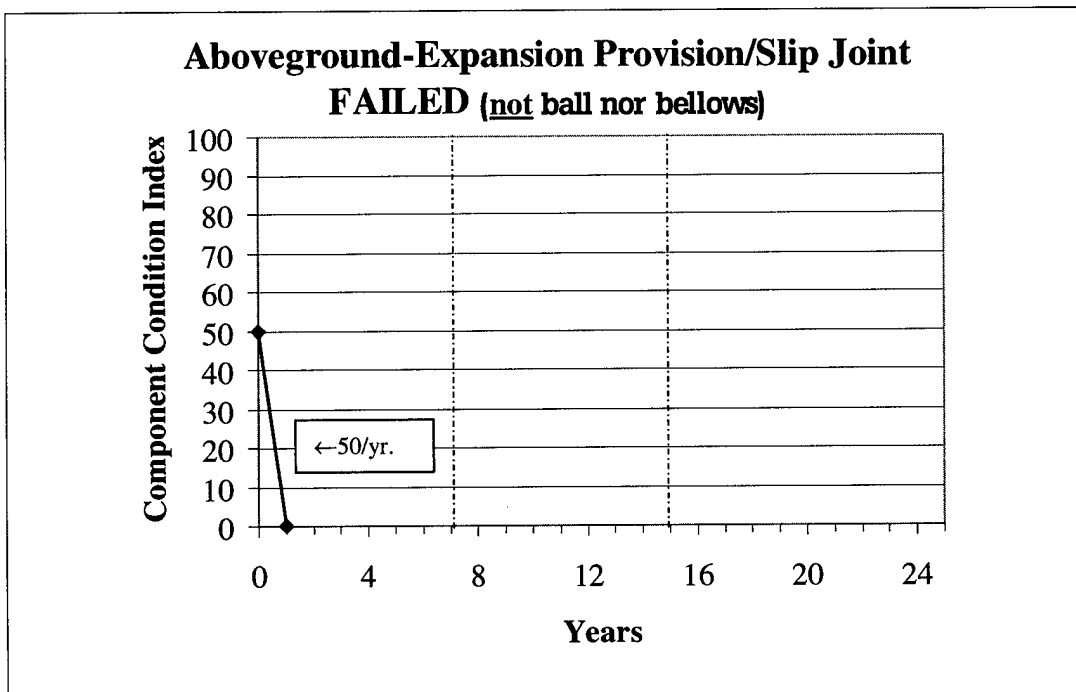

Note 1: In worst case, could interpret supply and be a safety hazard.

Note 2: With two on a single pipe, typically only one operates

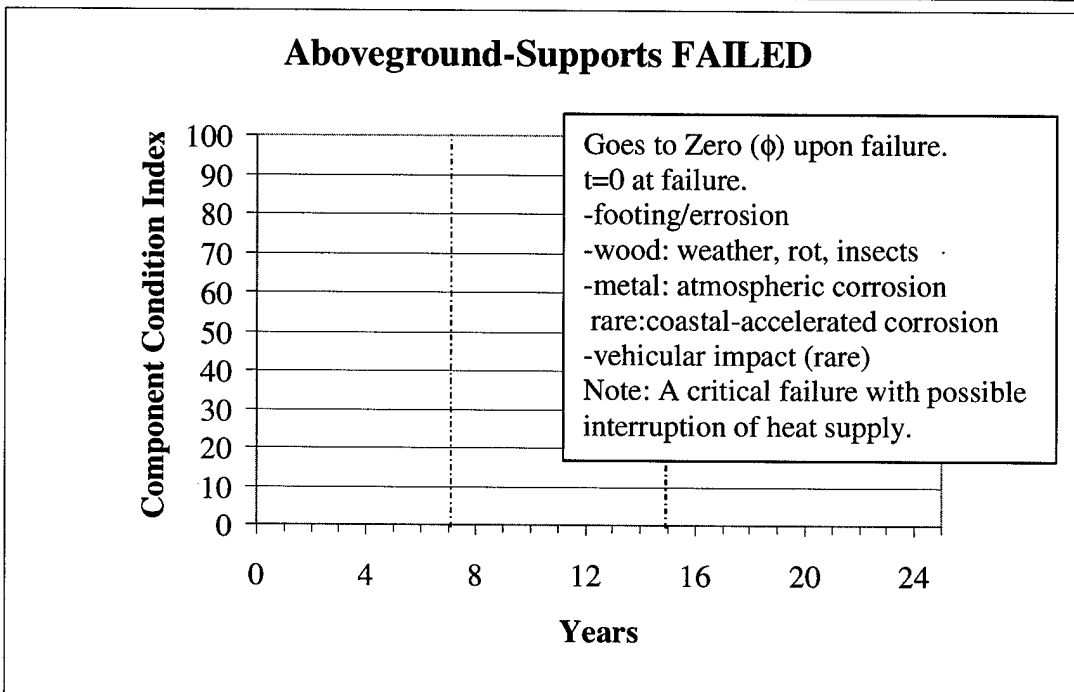
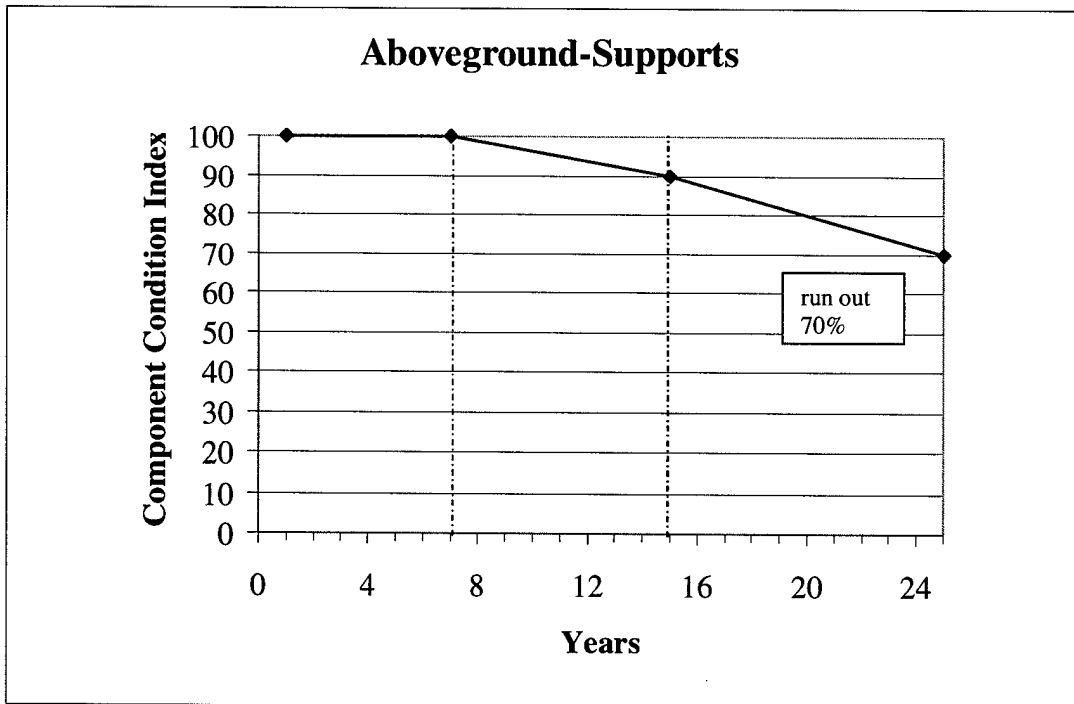

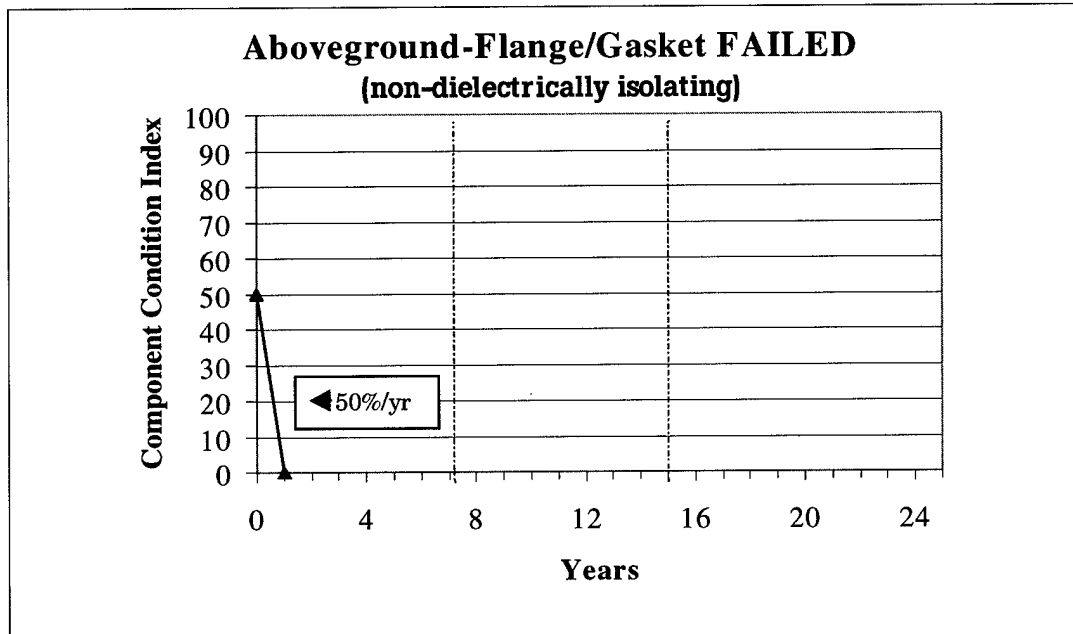
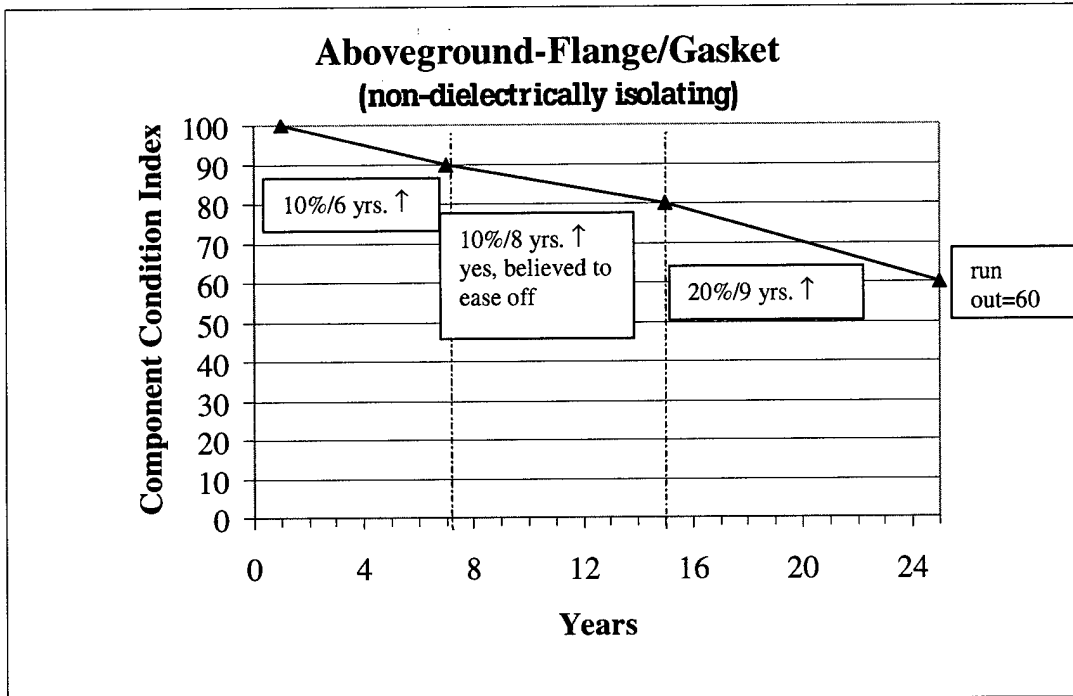

t=0 at failure.

Note: A blowing leak under pressure (even if only aboveground) will 1) lose significant heat, medium, treatment chemicals 2) get more worse quickly.

Note: Also, fairly quickly, the flange face will evade requiring replacements

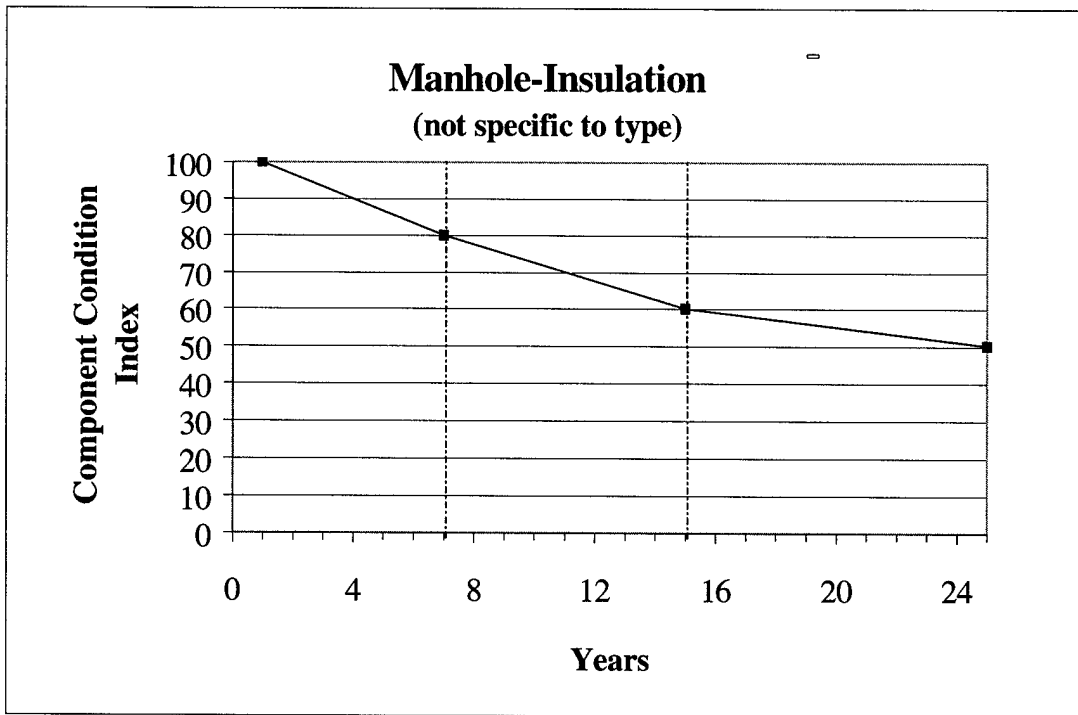

Typically damaged by leakage or flooding and less so by being stepped on. If all gone or off, pipes then 0.

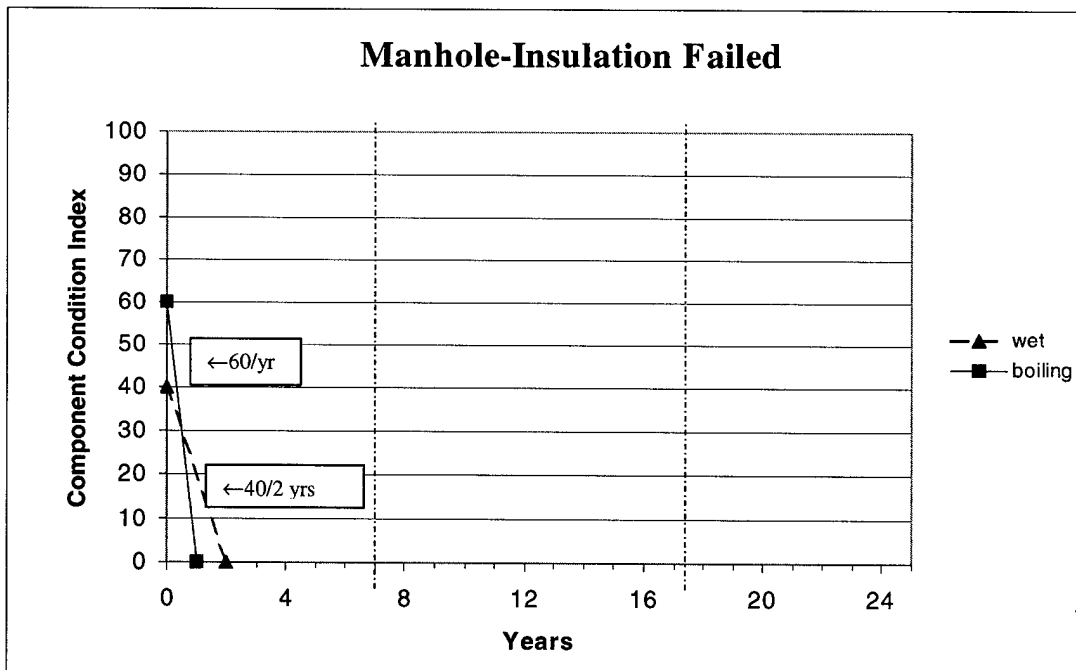

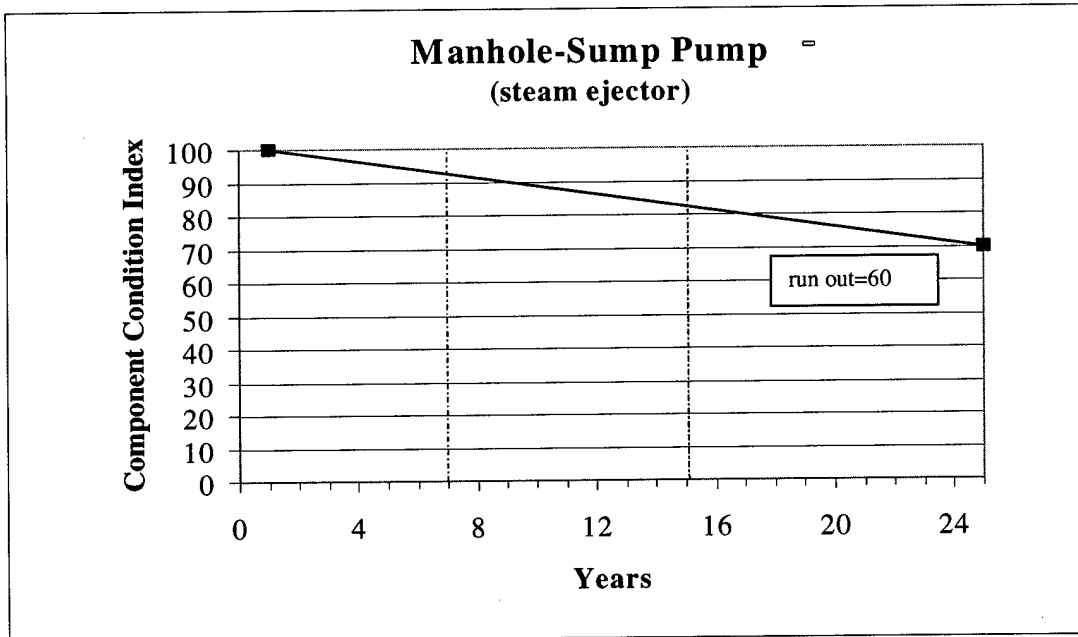

Note1: Only on steam systems.

Note 2: FAILED=not pumping=•.

Note 3: IF no steam being supplied then CI=0 temporarily.

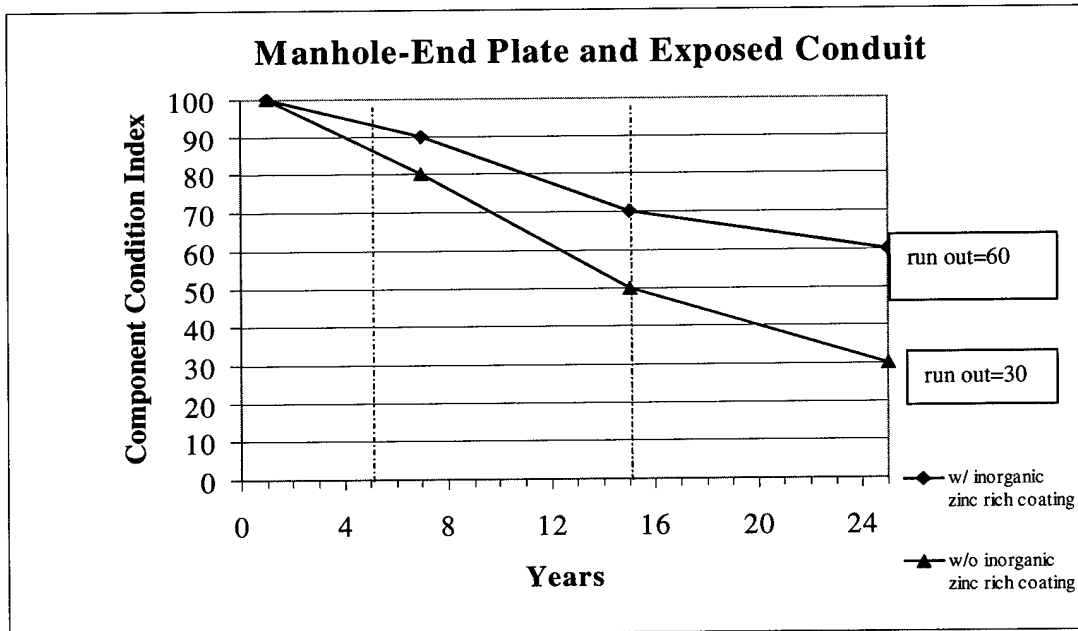

Note:1 Exposed conduit more likely to fail first since thinner.

Note 2: Inorganic zinc rich coating (with no topcoat) will

Note 3: Strongly dependent on manhole enviroment.

Note 4: FAILED=hole (typically from corrosion)=0

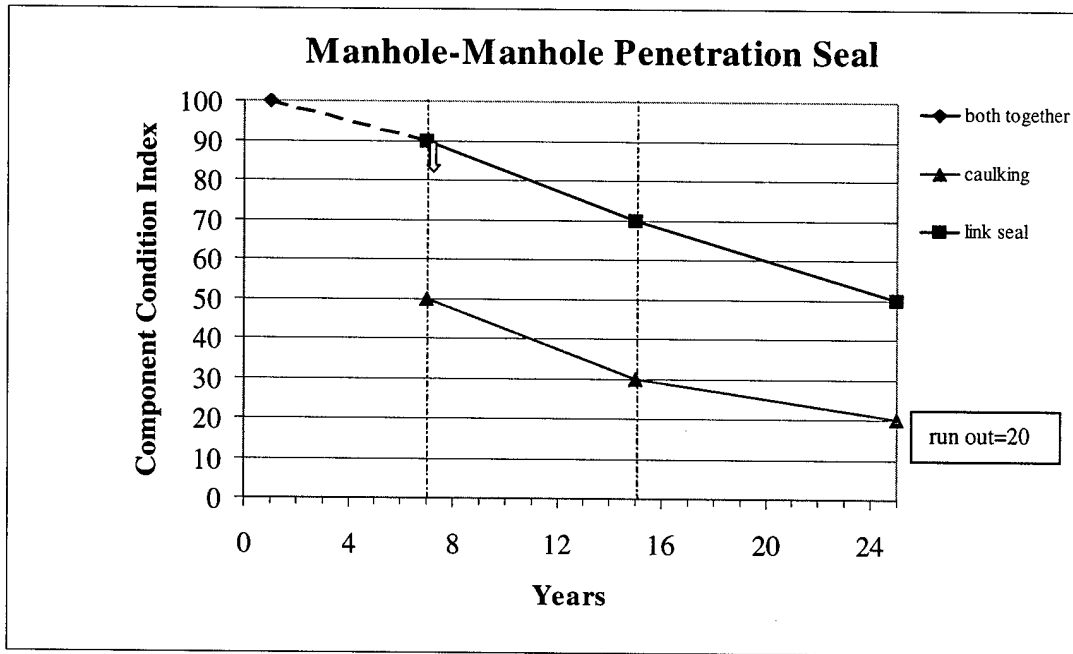

Note: Caulking tends to last about 7 years.

Note: Link seal assumes at least re-tightening.

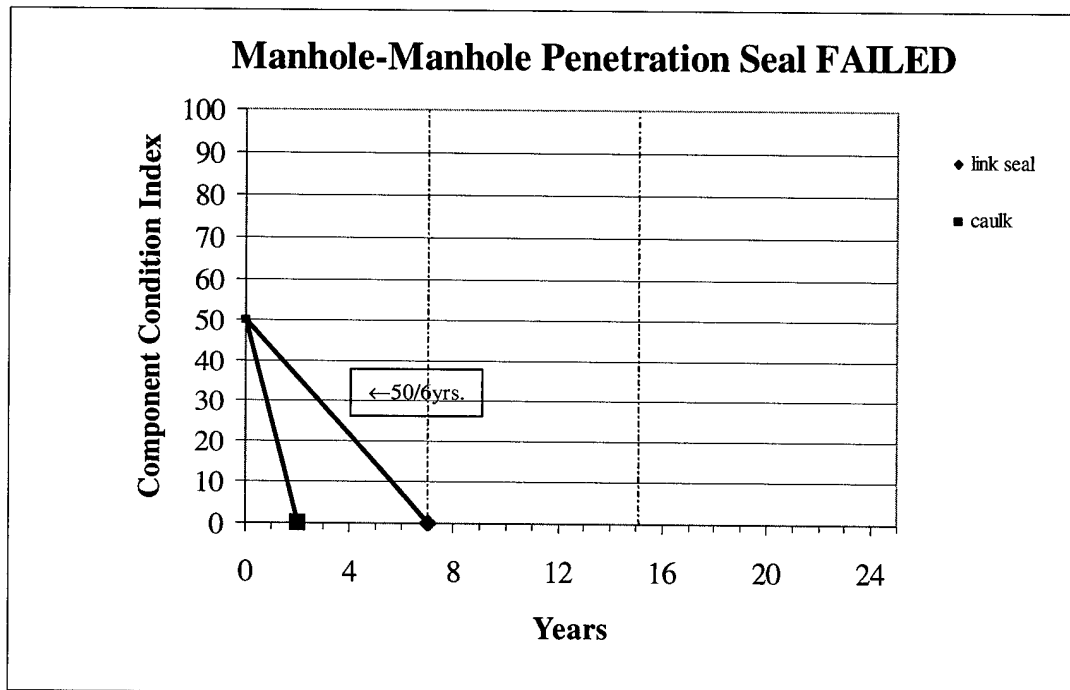

Caulk will fail more quickly (larger in flaw) once a leak starts. Link seal fail rate assumes tightening bolt corrosion and possible polymeric material breakdown

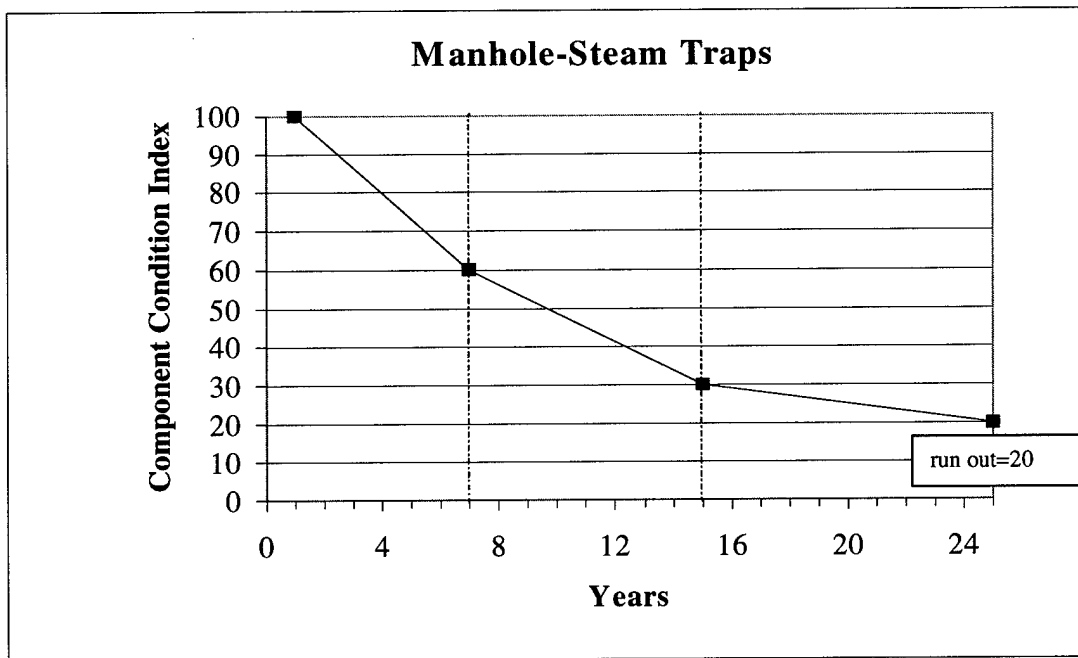

FAILURE=0, according to type, can fail open blowing steam (a considerable waste of energy) or fail closed by not removing any condensate (adds to potential for water hammer).

Note: steam traps are mechanical devices that experiences relatively continuous use

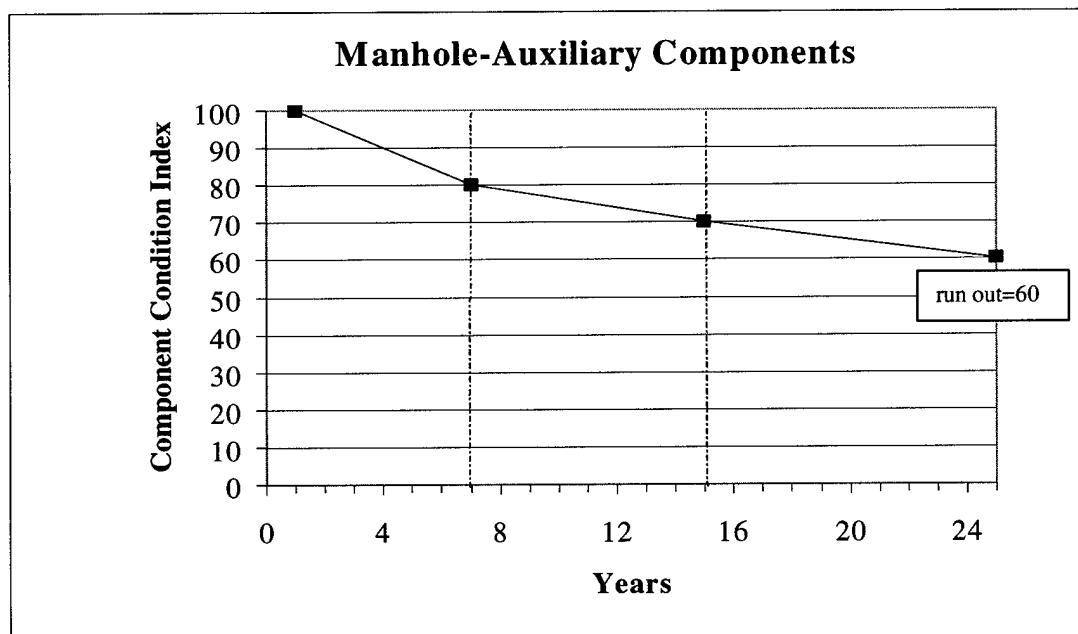

FAILED=0 (not performing intended function).

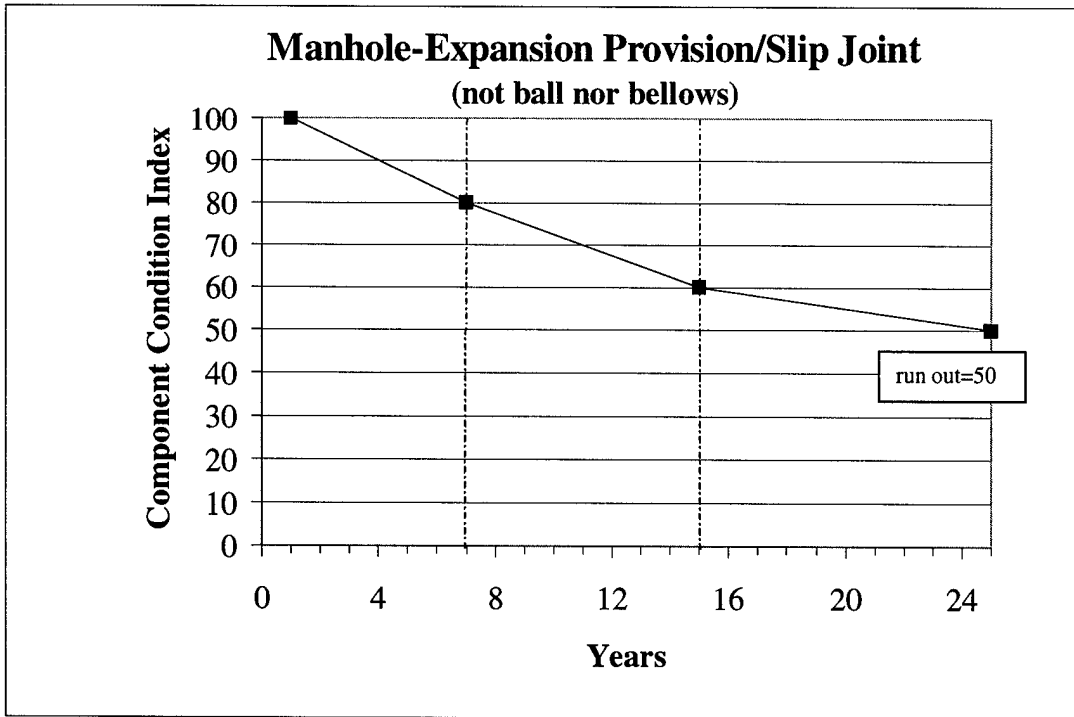

Note: A little more severe compared to aboveground because of typical manhole environments. Manhole-expansion provision (typically do not have loops, and elbows typically don't fail to any significant degree).

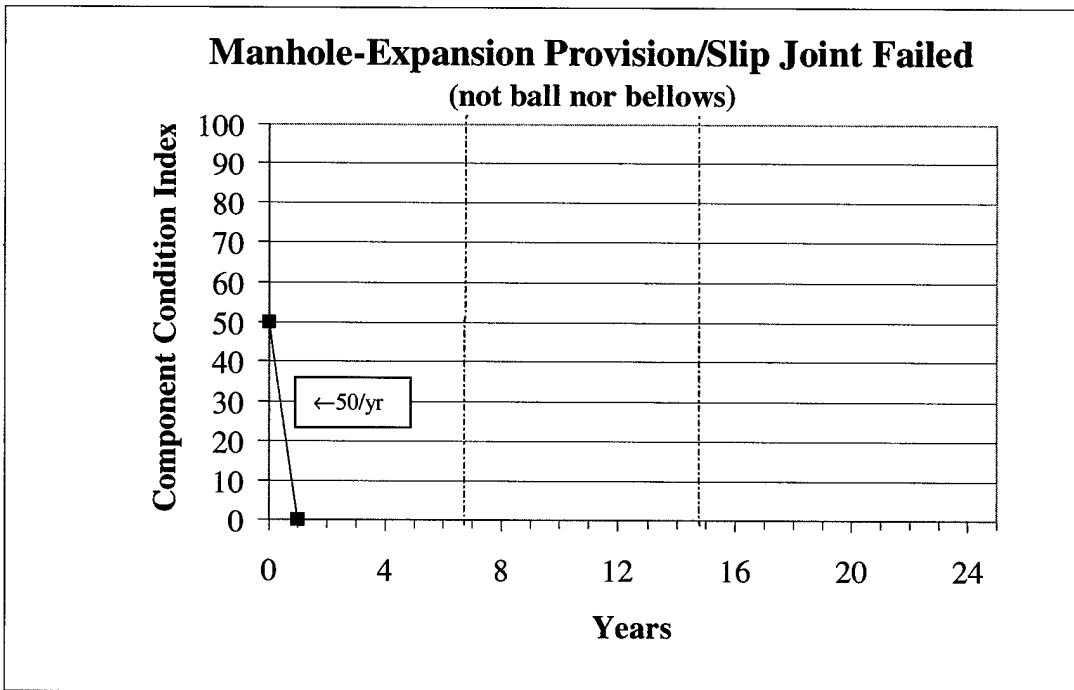

Note: (see failed aboveground-2nd note does not apply)

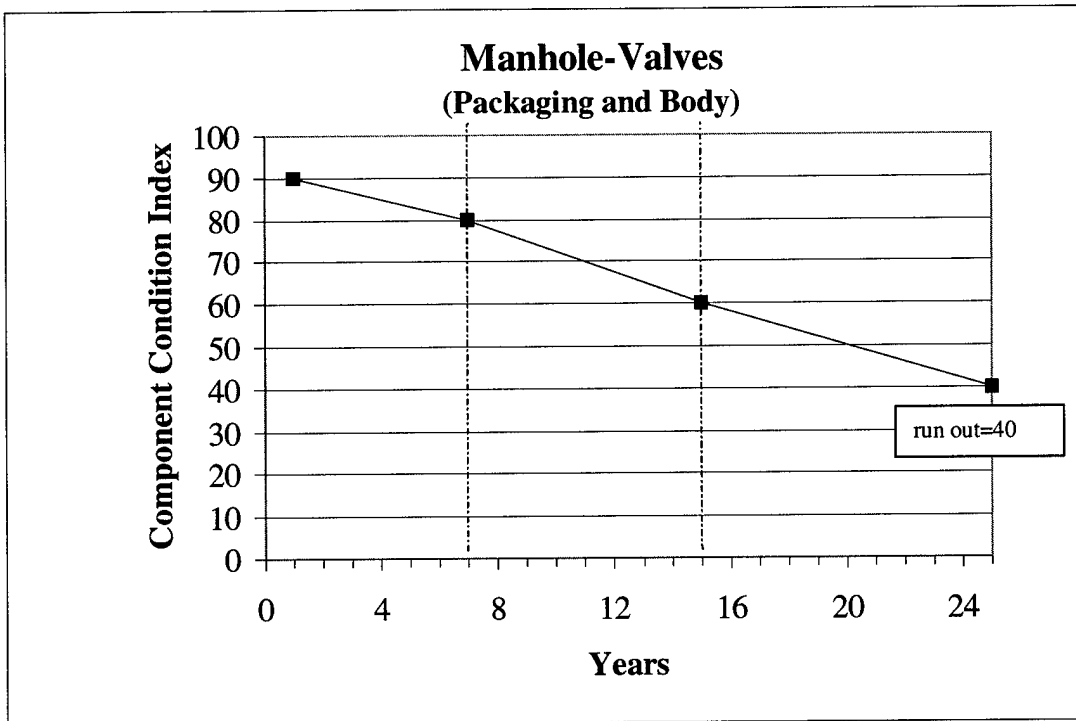

Note: Failure of valve body is rare.

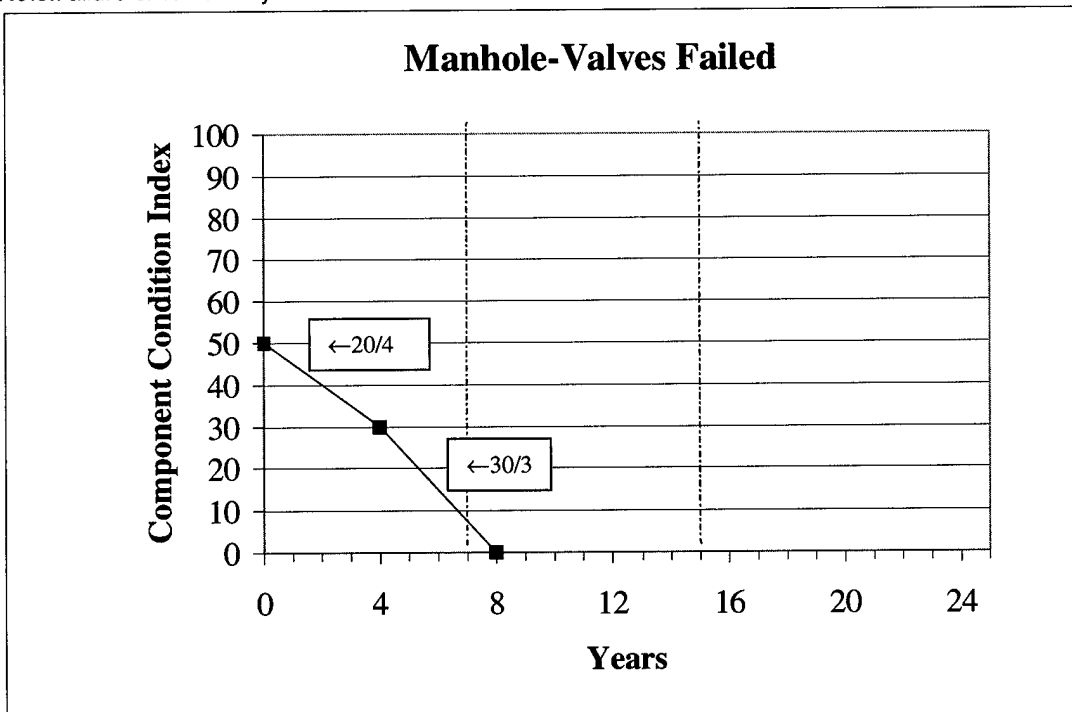

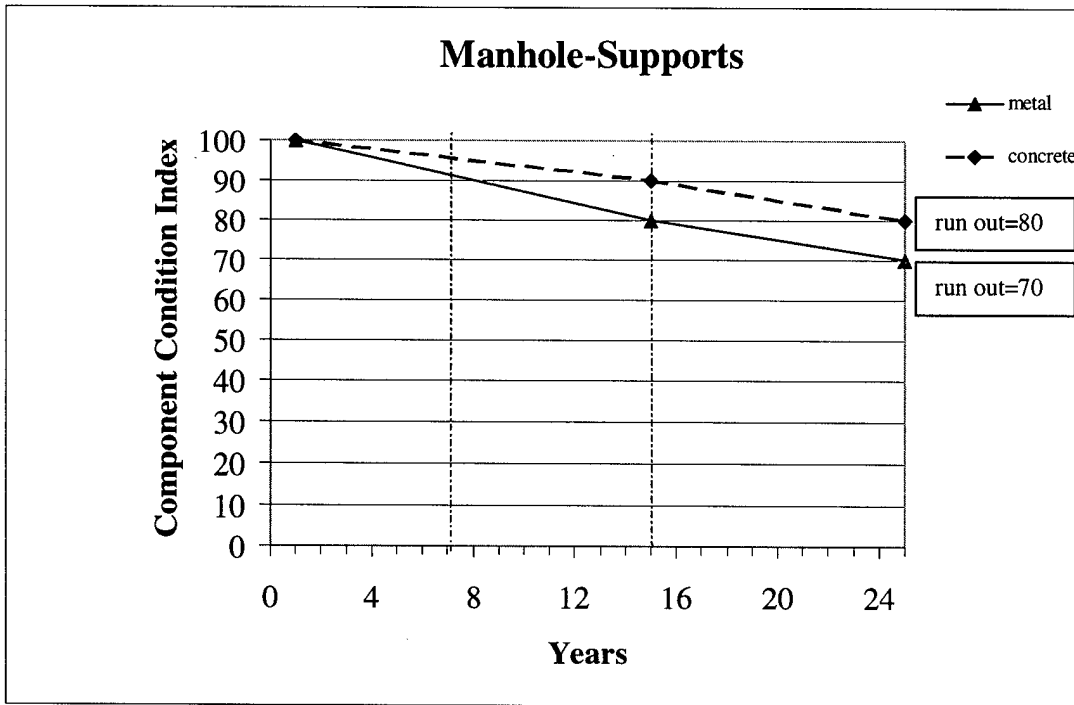

FAILED=•

Note: Standing water can corrode metal supports.

Note: Excessive stress and/or expansive corrosion products can crack concrete supports.

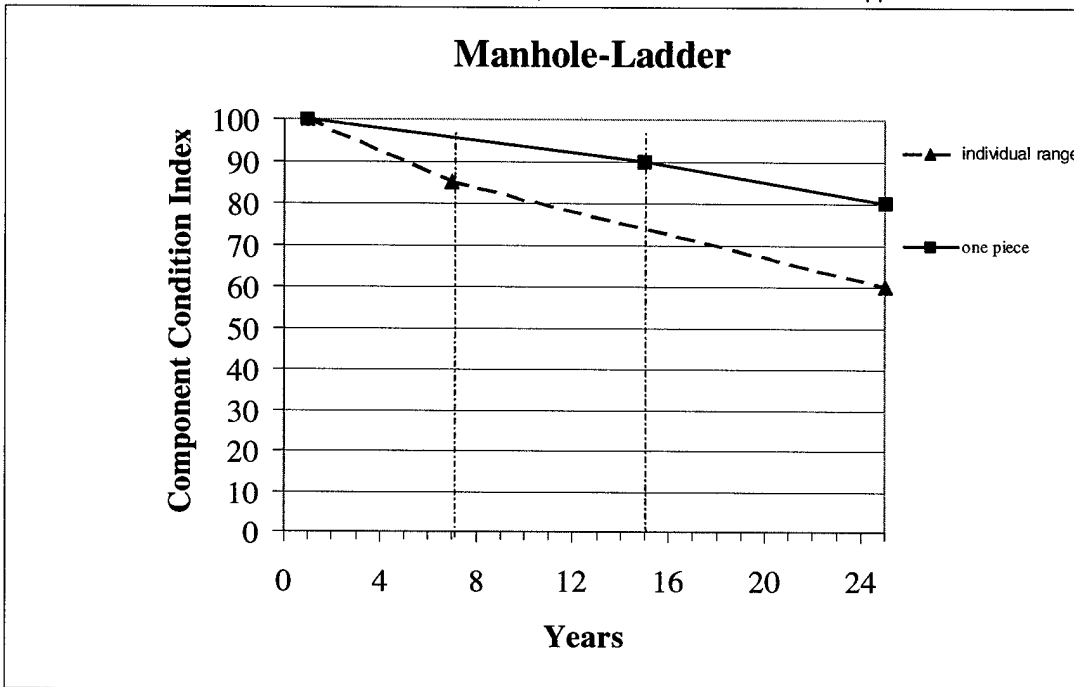

FAILED=• (defined by when unsafe to use)

Note: For safety, this component may need to be replaced for CI of 50 or less.

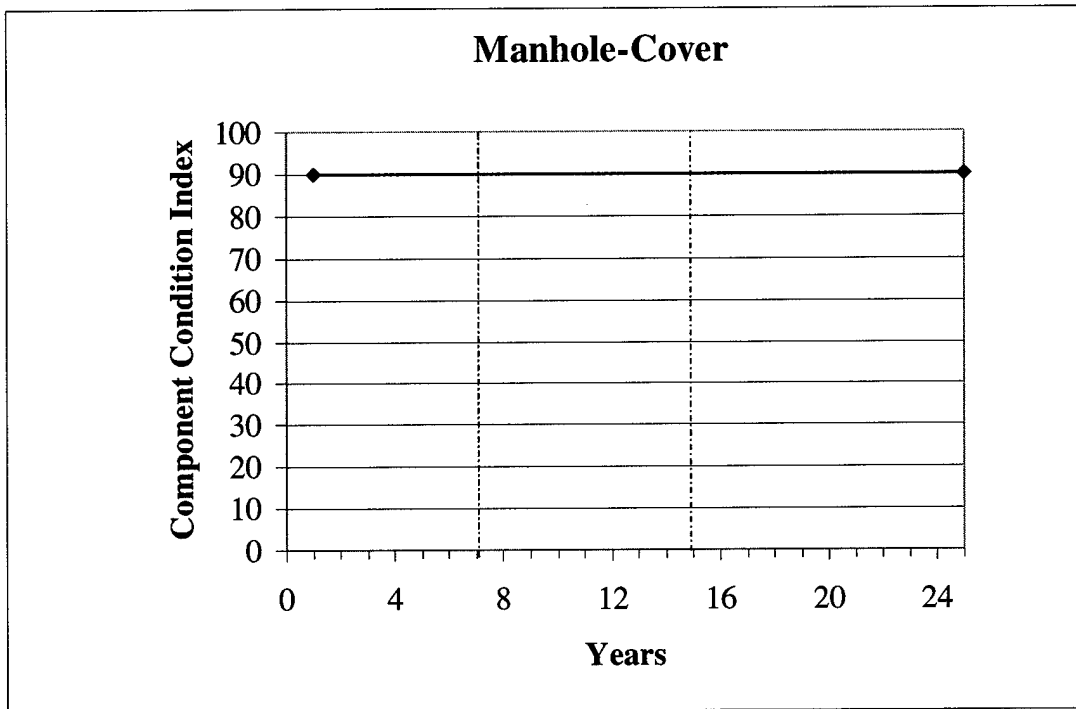

FAILED=0 (but probably not applicable)

Note: For cast concrete, open grate, raised top checkered plate.

Note: Typically do not fail.

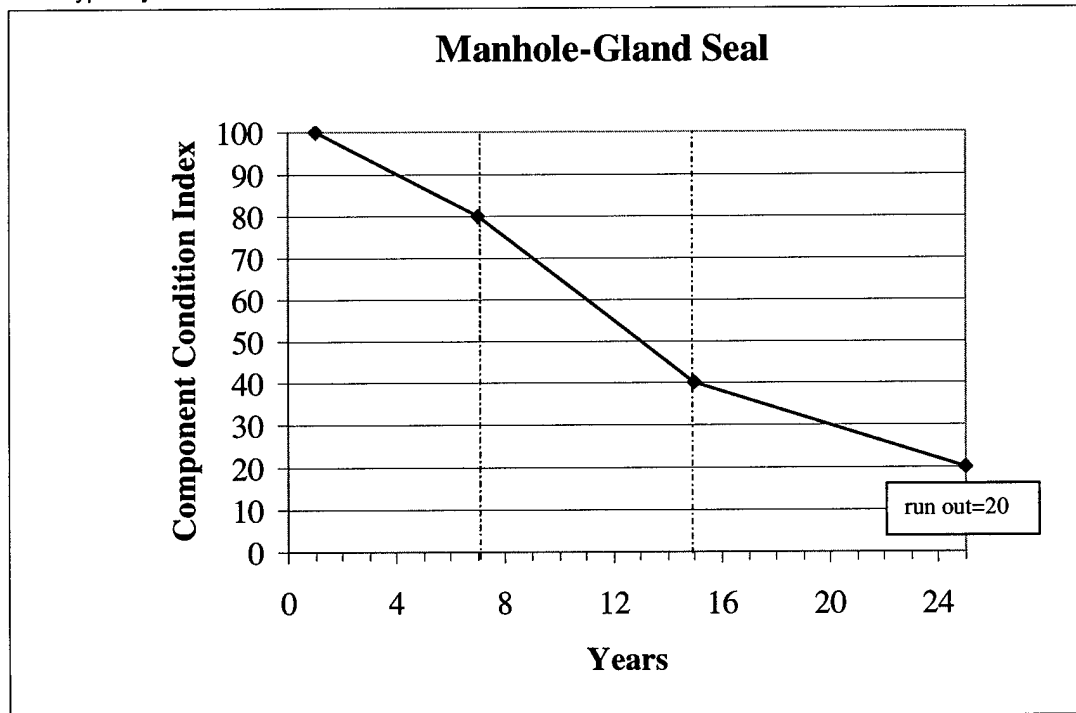

FAILED=0

Note: Either observed to let water pass or cannot be tightened sufficiently for a conduit pressure test.

Note: Require periodic tightening and occasional repacking.

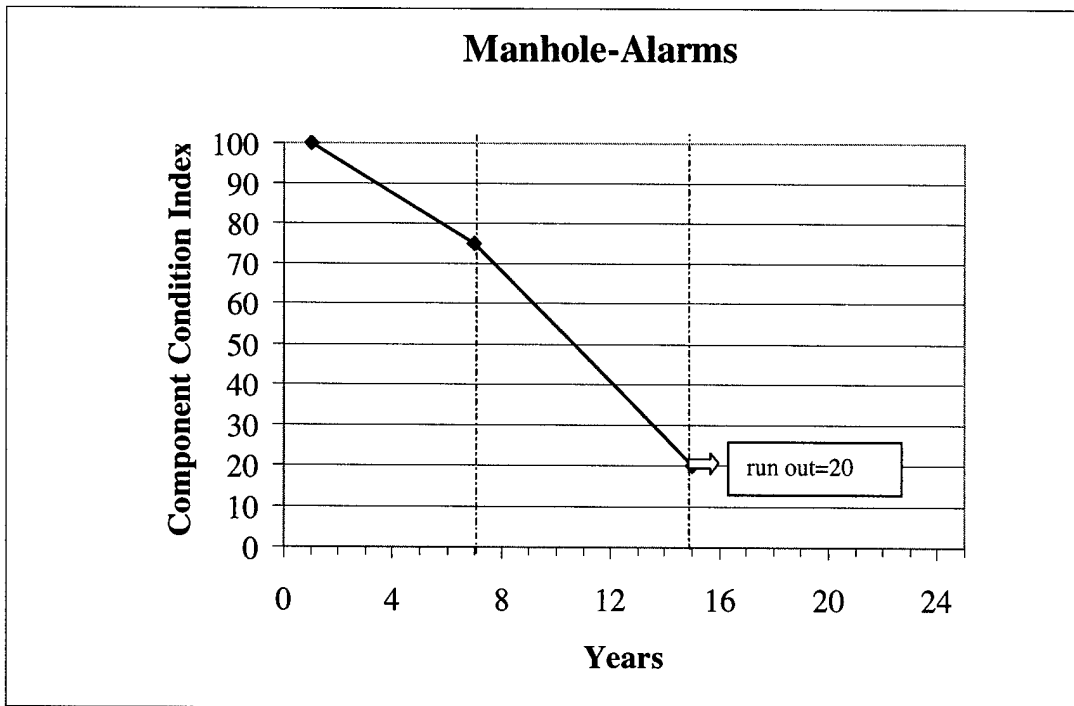

FAILED=0 (no alarm when tested)

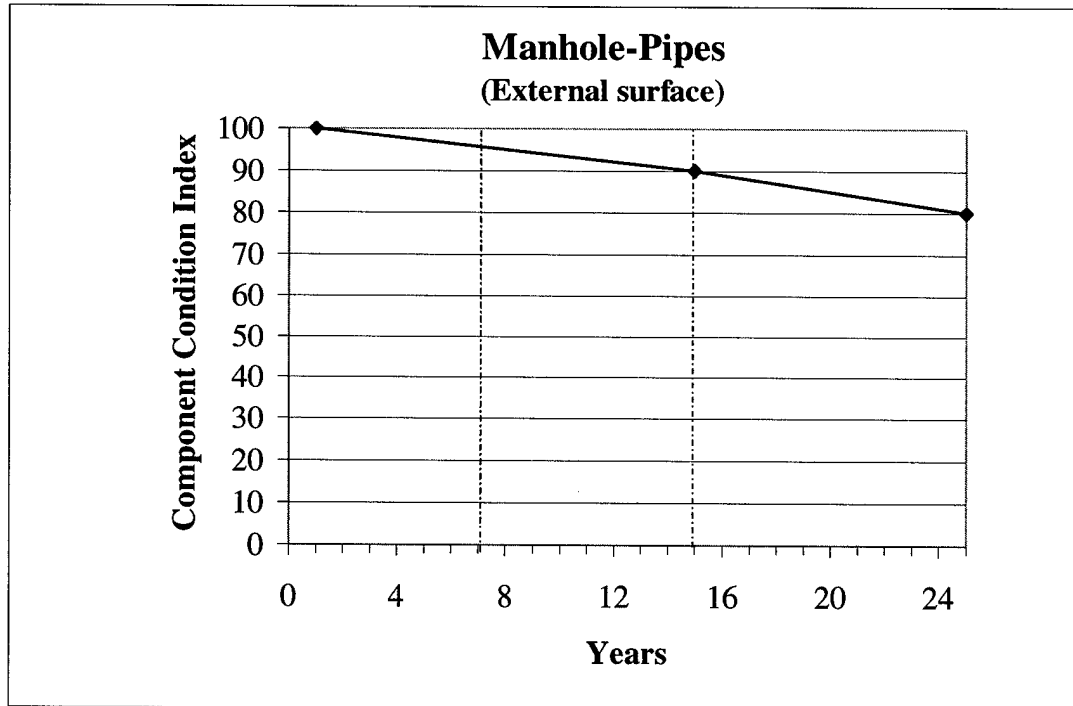

Note: For internal condition index see corrosion model.

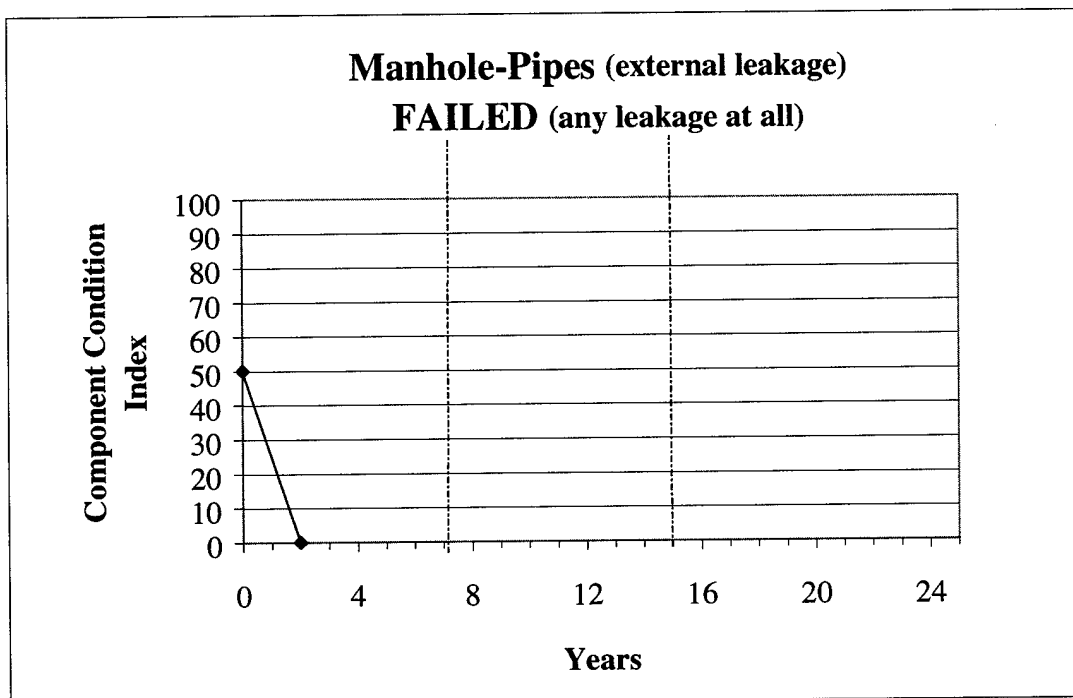

Note: More likely to see condensate pipe leakage due to the more severe internal corrosion.

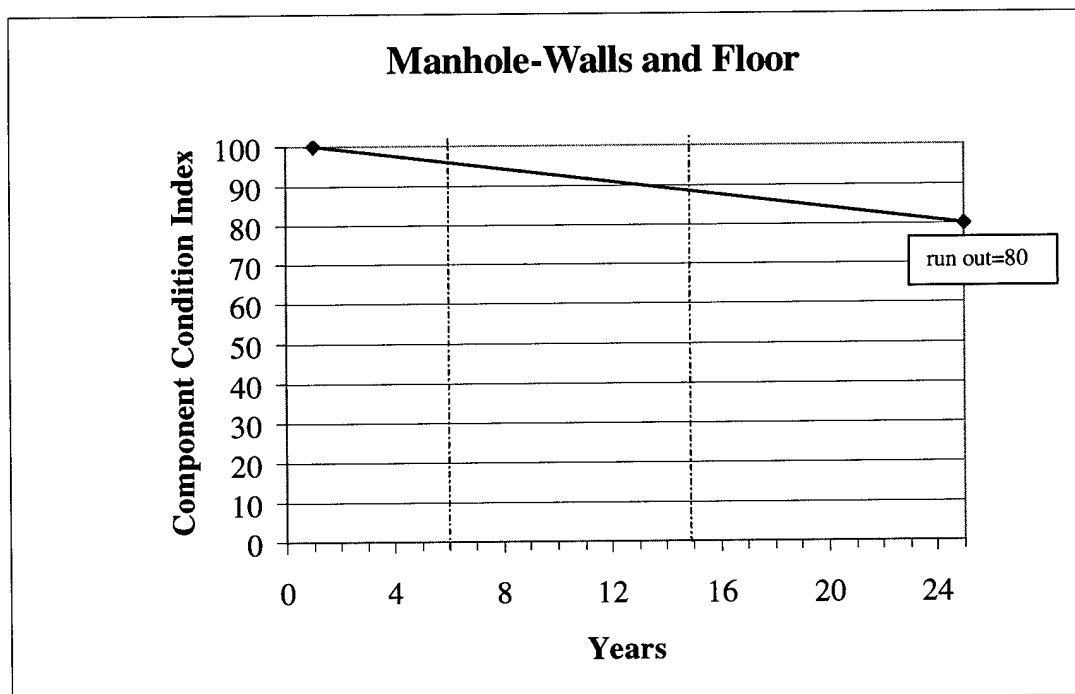

Note: Not applicable to sealable metal manholes.

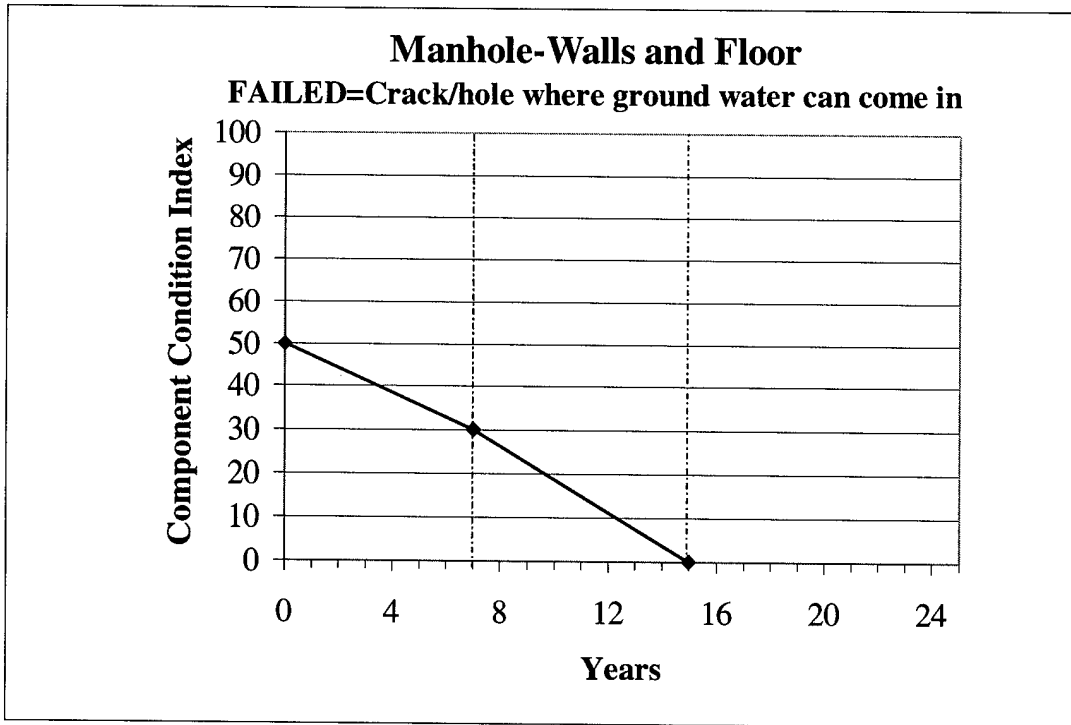

FAILED=not pumping=0

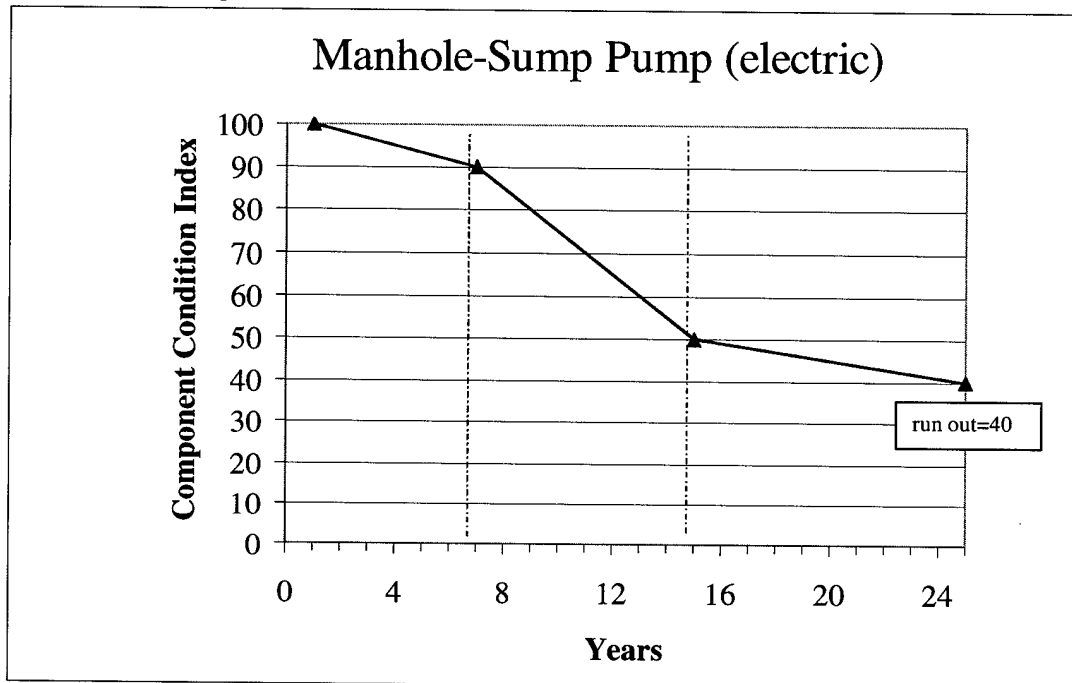

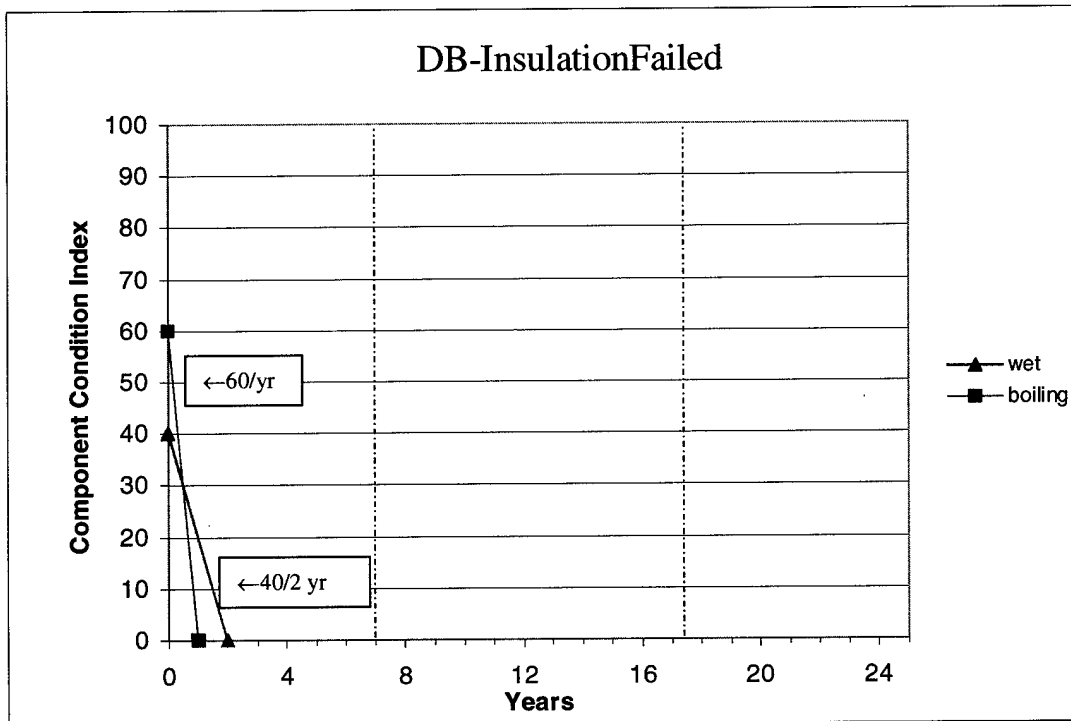
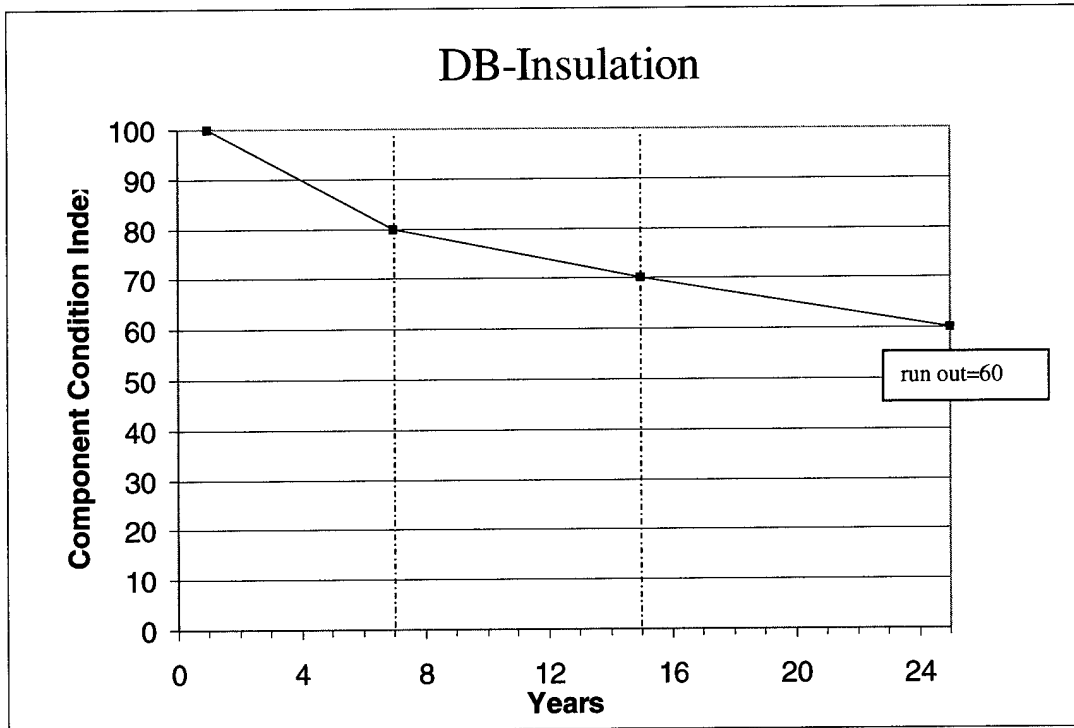

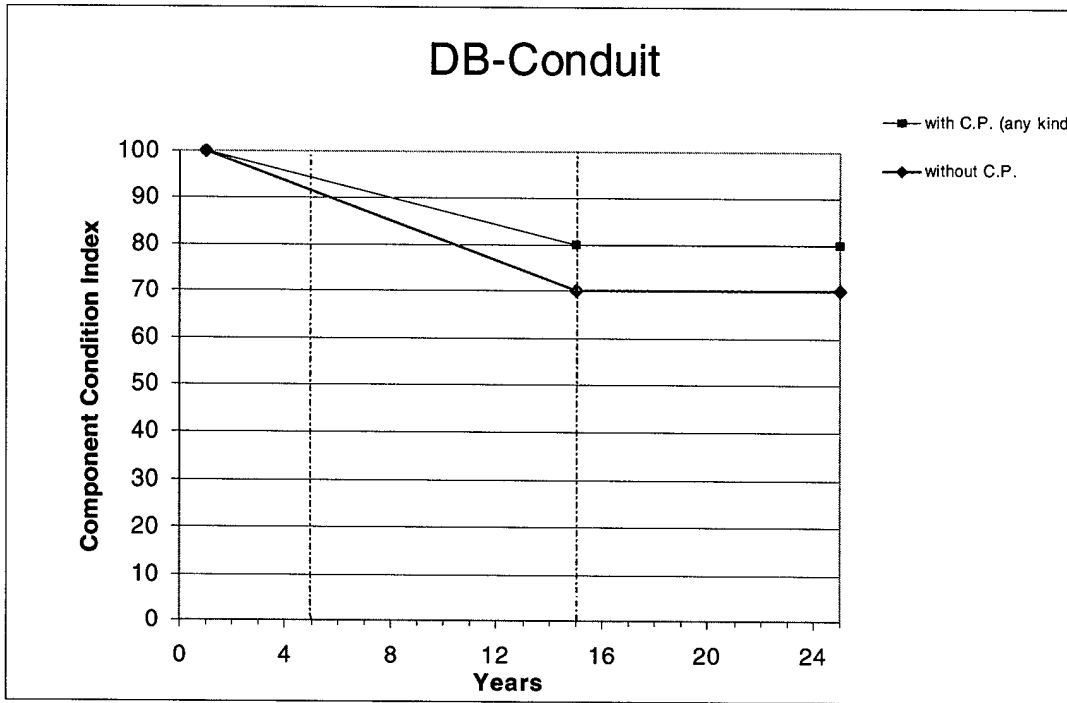

Note: See external corrosion model (g piper or UST related)

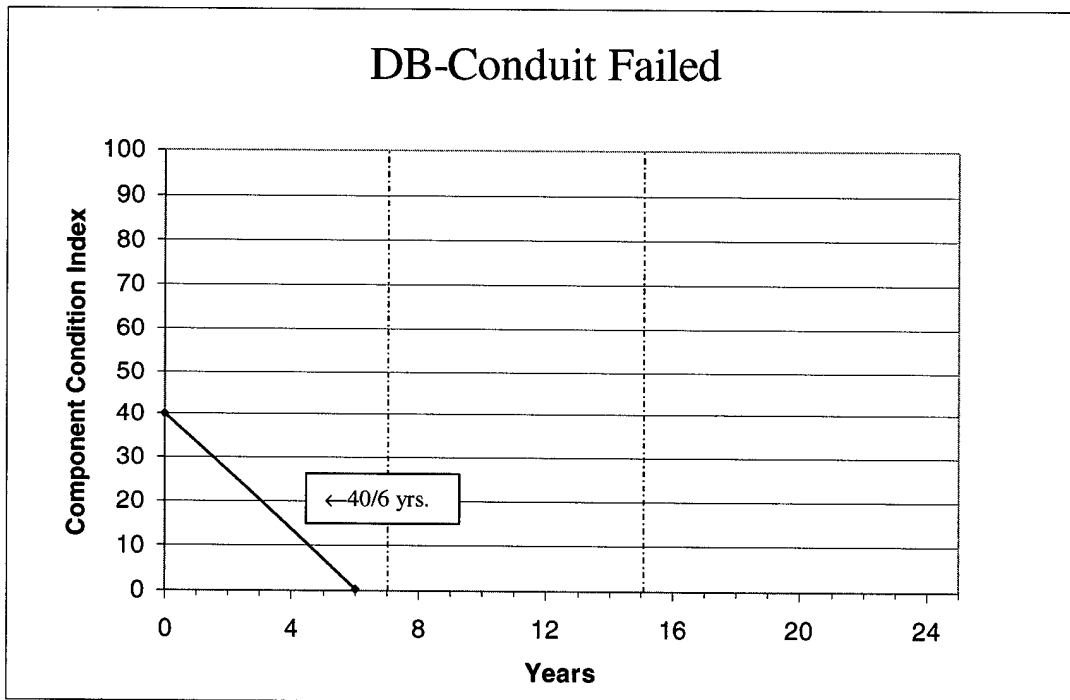

Note: Failed verified by 1) unable to pass a pressure test or 2) water form drain that does not contain treatment chemicals.

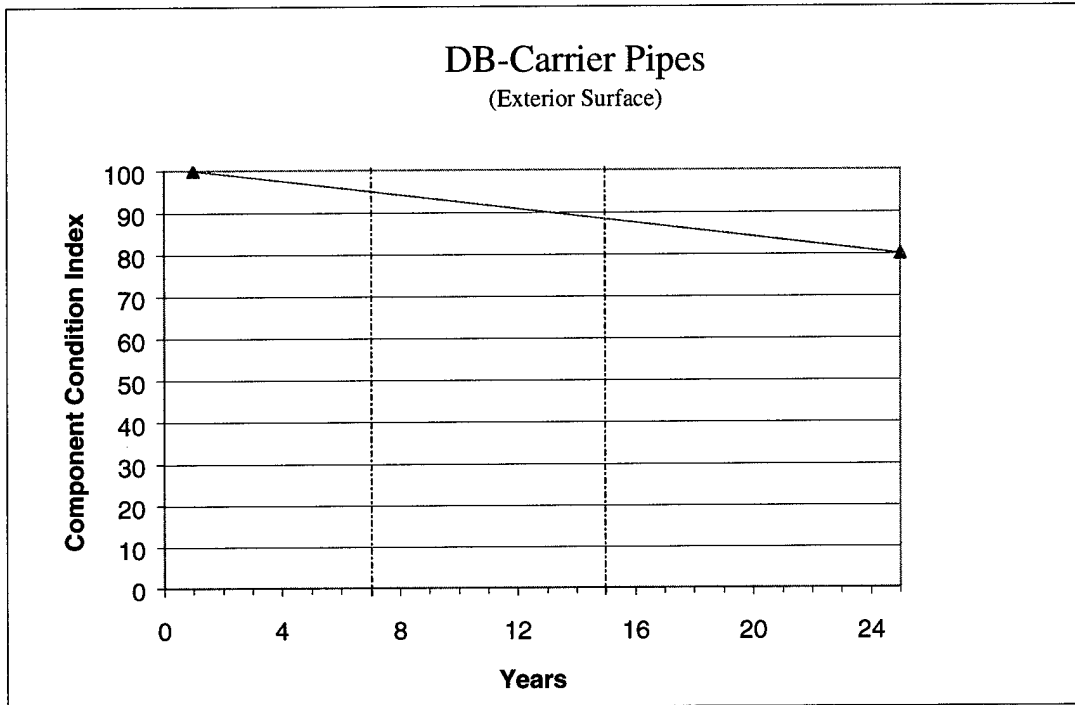

Note: For internal CI see corrosion model.

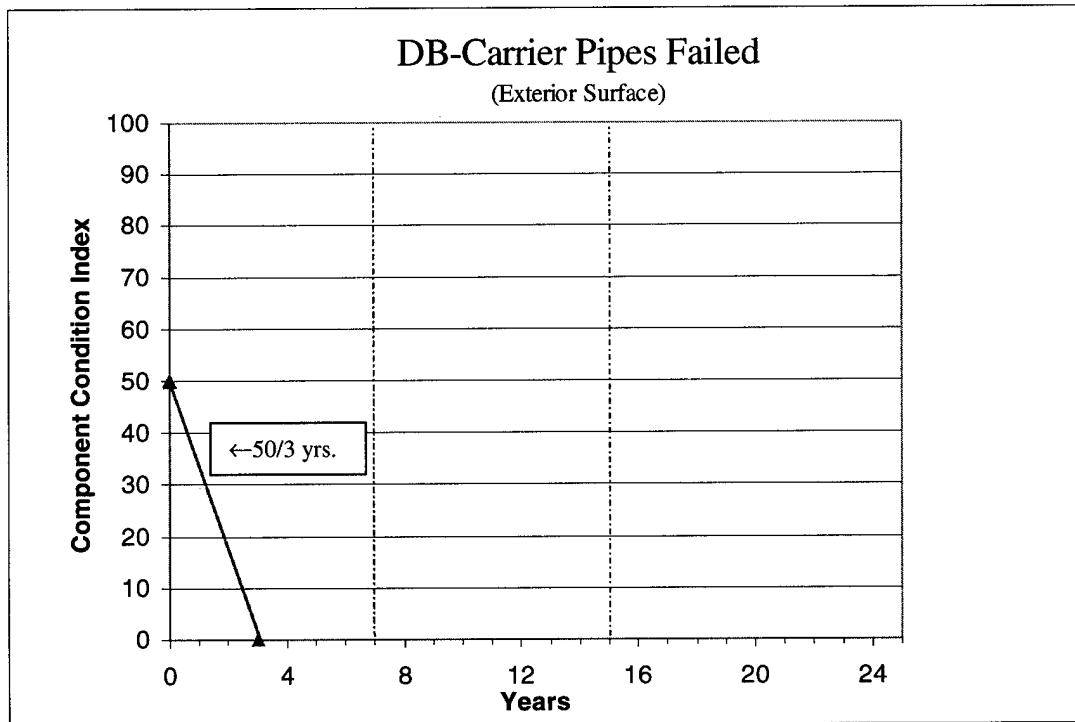

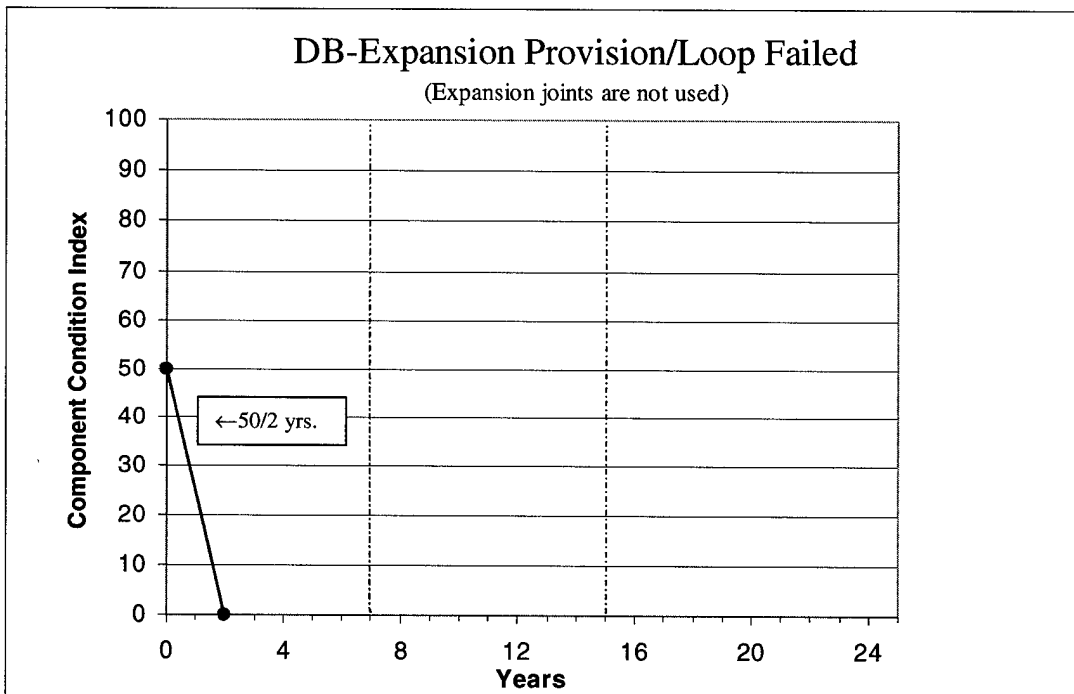
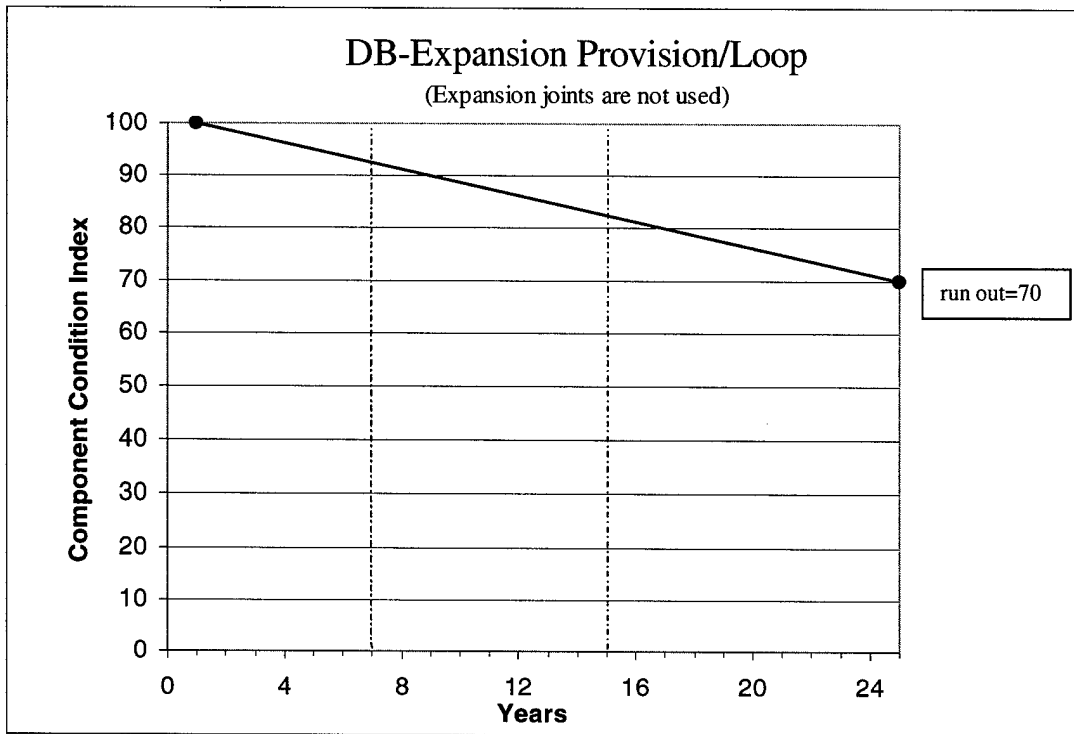

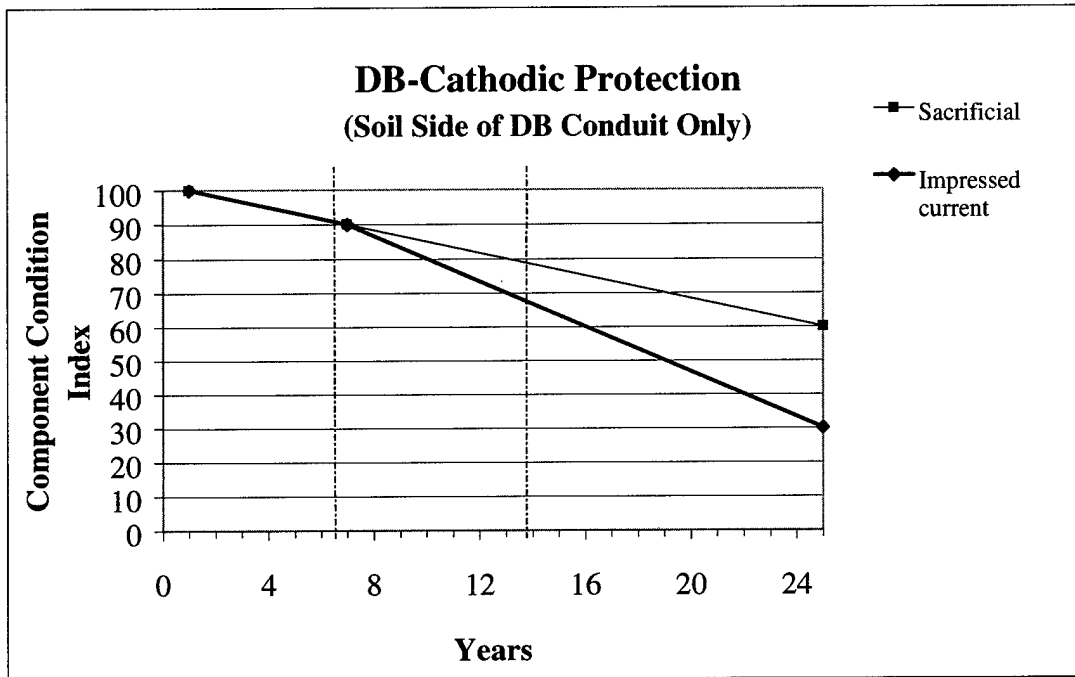

Failed=0

Note: Typically systems are not maintained so sacrificial has better chances. For large projects impressed current systems are more common.

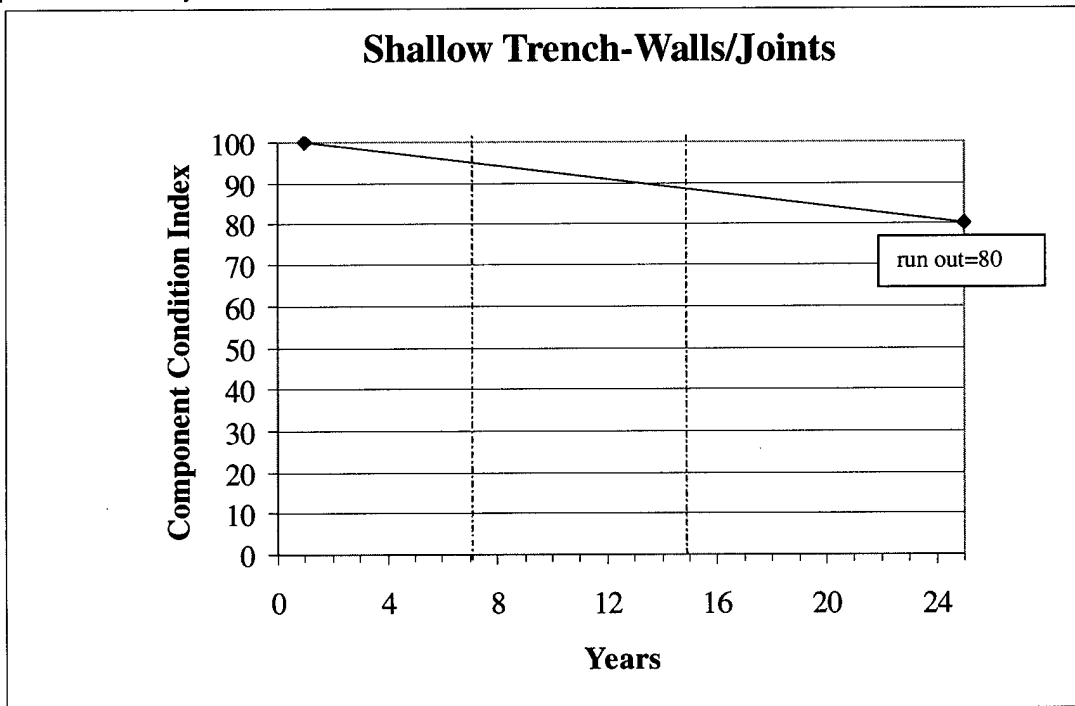

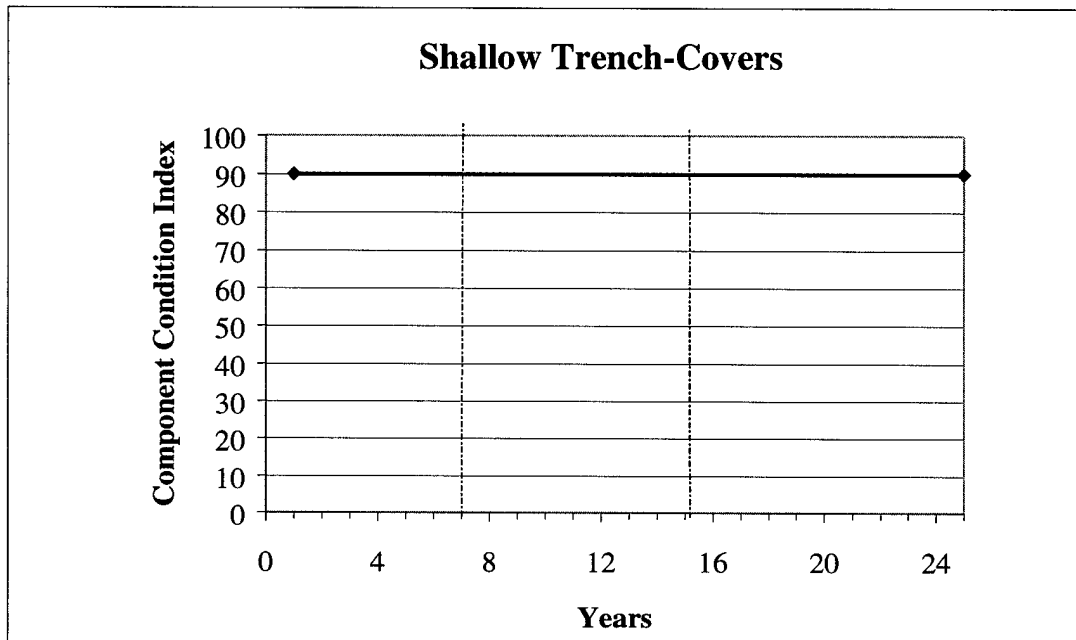
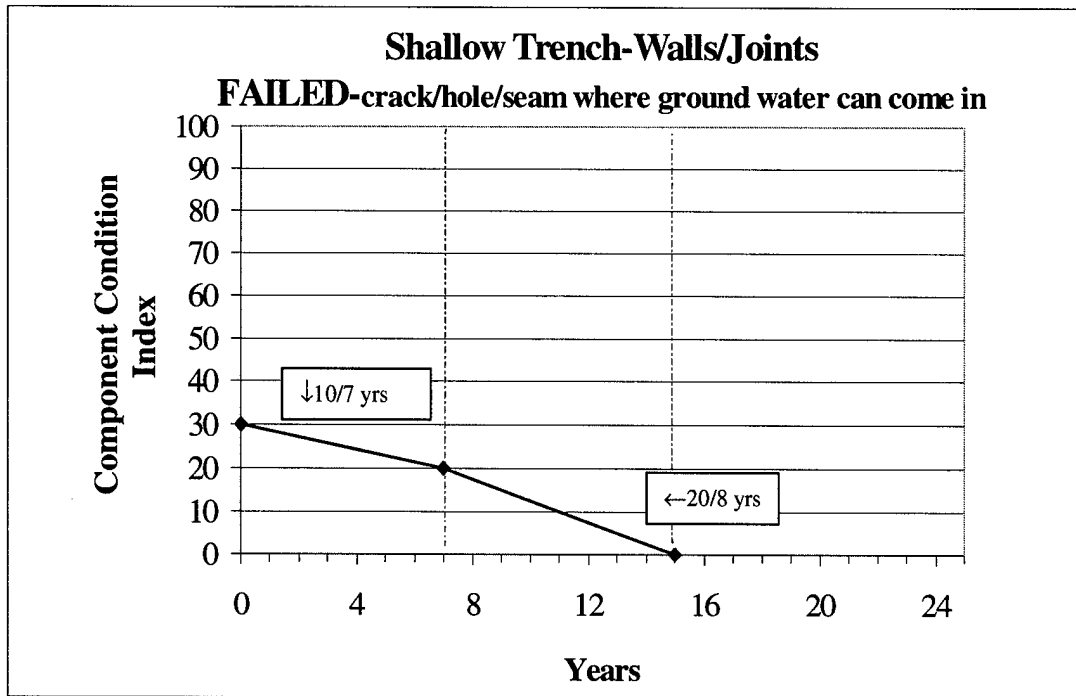

FAILED=70 if neoprene (or other) seals forgotten.

FAILED=0 if structurally unsound (so rare as to not be applicable).

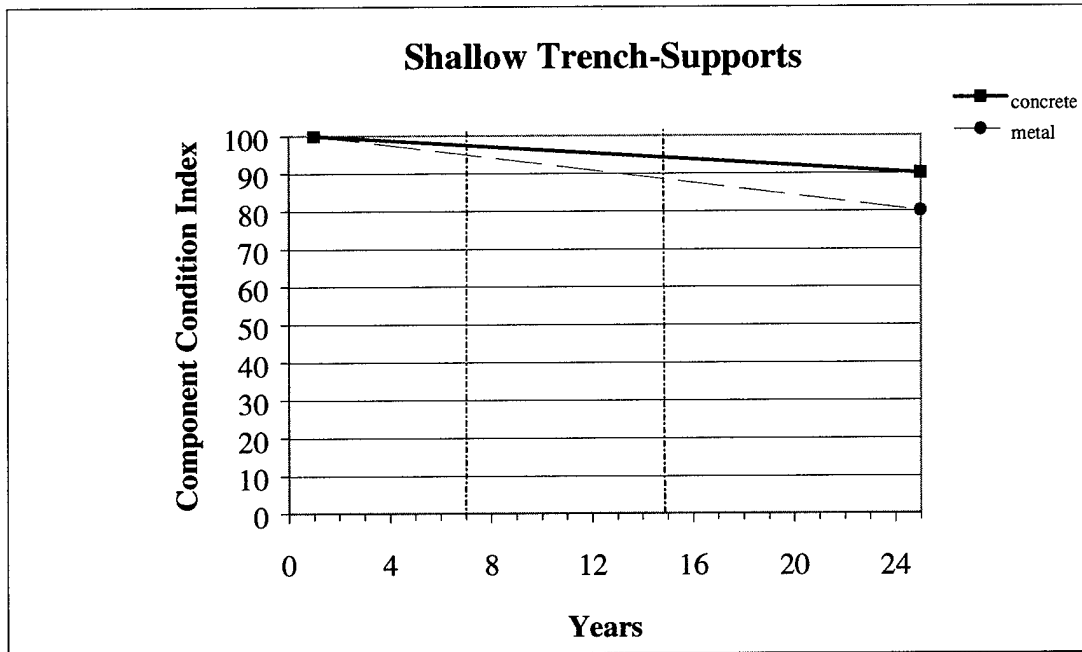

FAILED=40 (one non-support)

FAILED=0 (for two ore more in a row)

Note: Support type determined by predominant material for the first two inches above trench floor.

Note: Slide supports in coastal environments are less reliable compared to rollers.

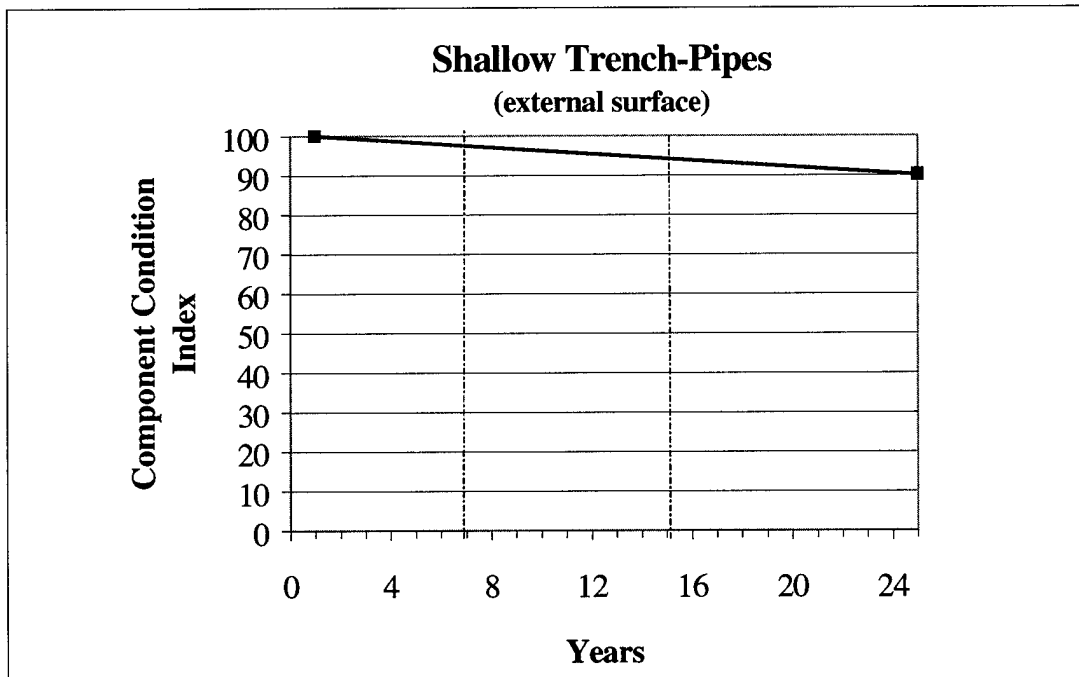

Note: For internal condition index, see corrosion model.

Note: More likely to see condensate pipe leakage due to the more severe internal corrosion

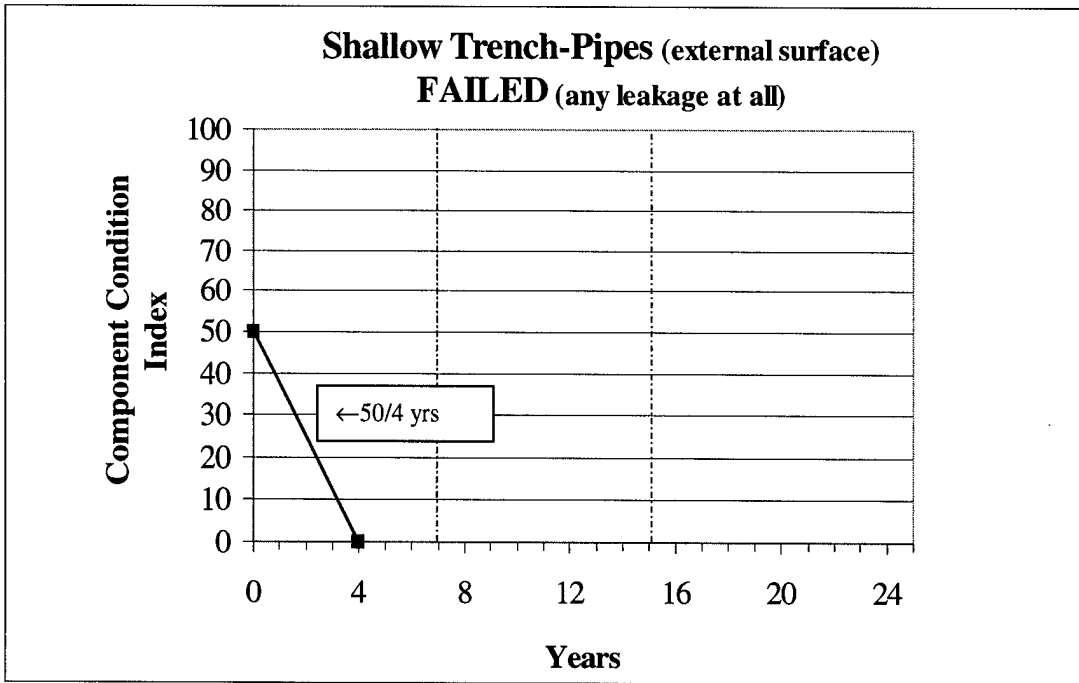

Note: More likely to see condensate pipe leakage due to the more severe internal corrosion

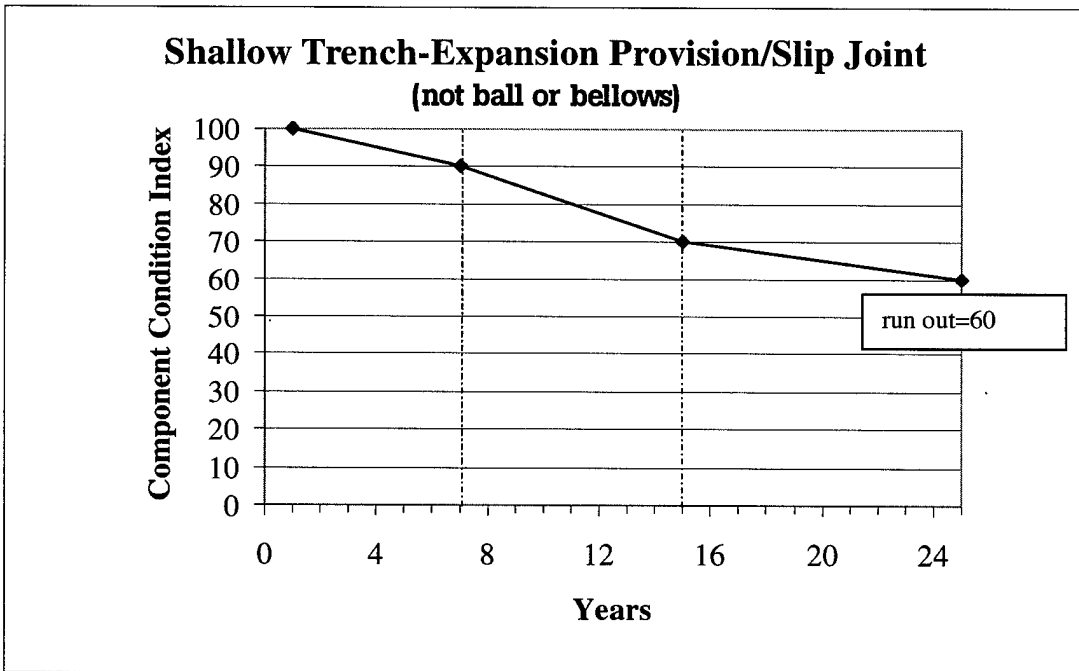

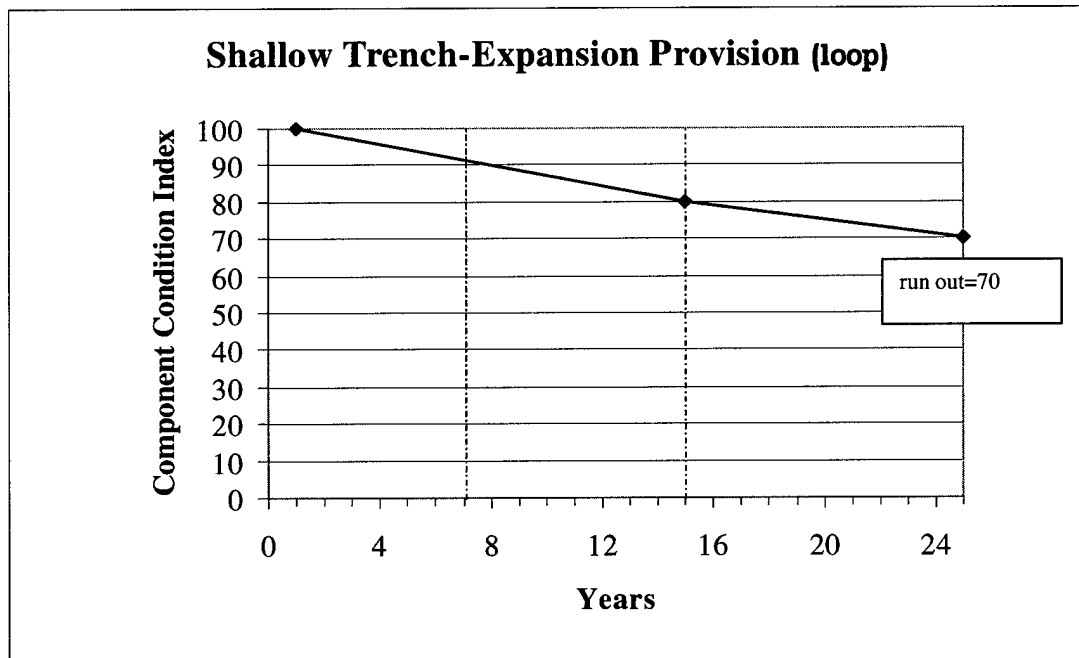
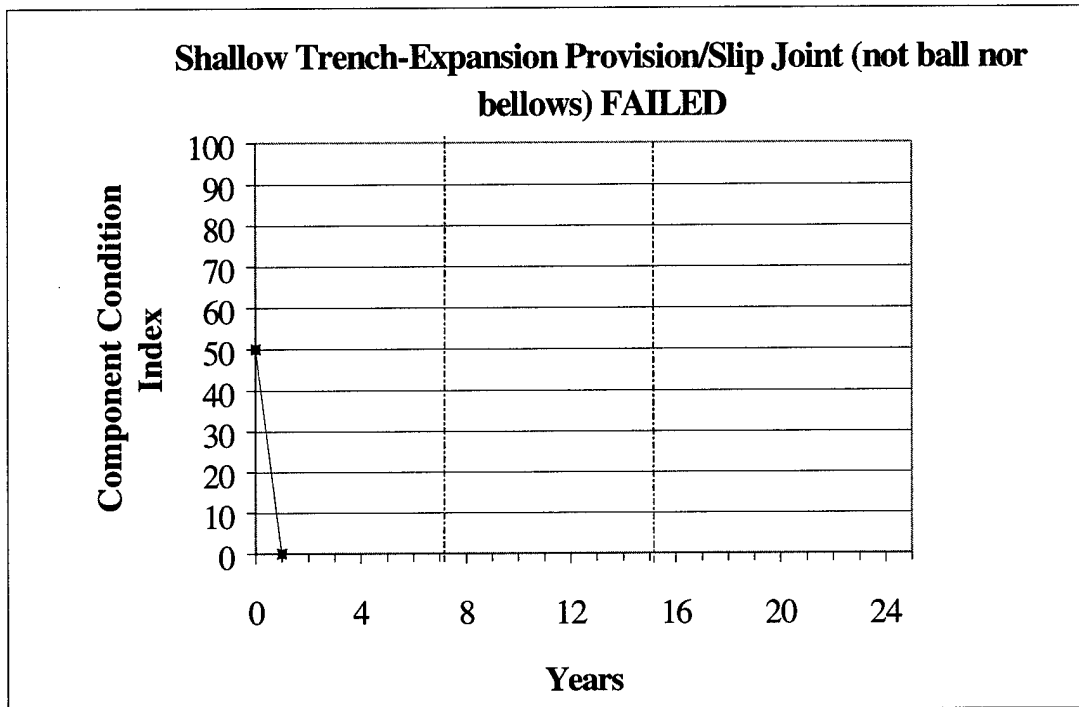

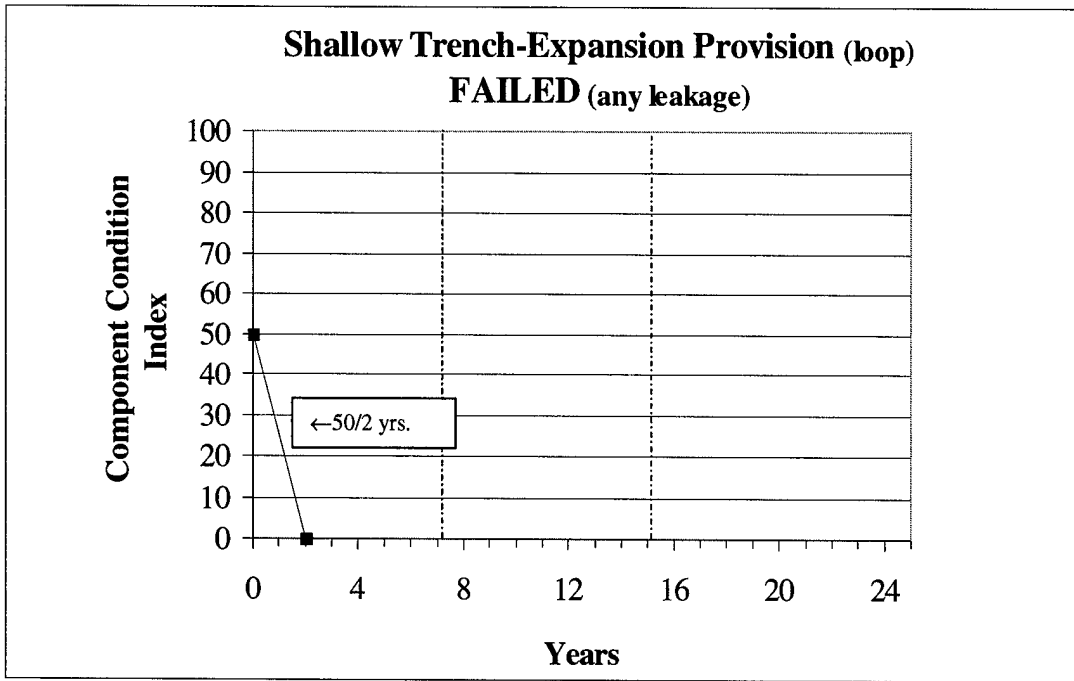

Note: Will not see old style loops

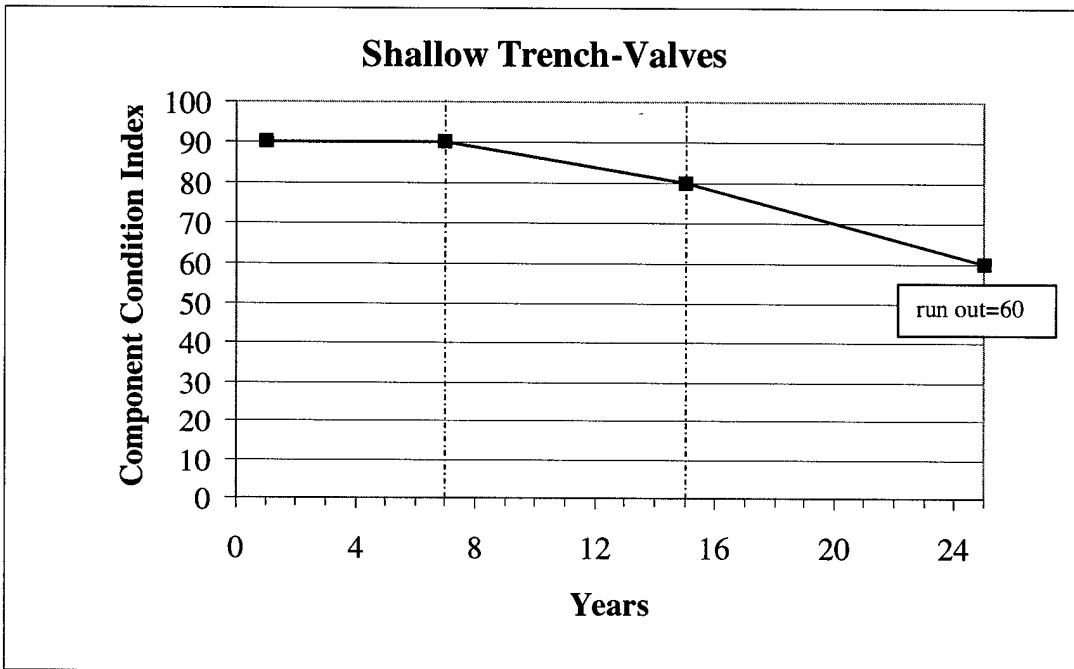

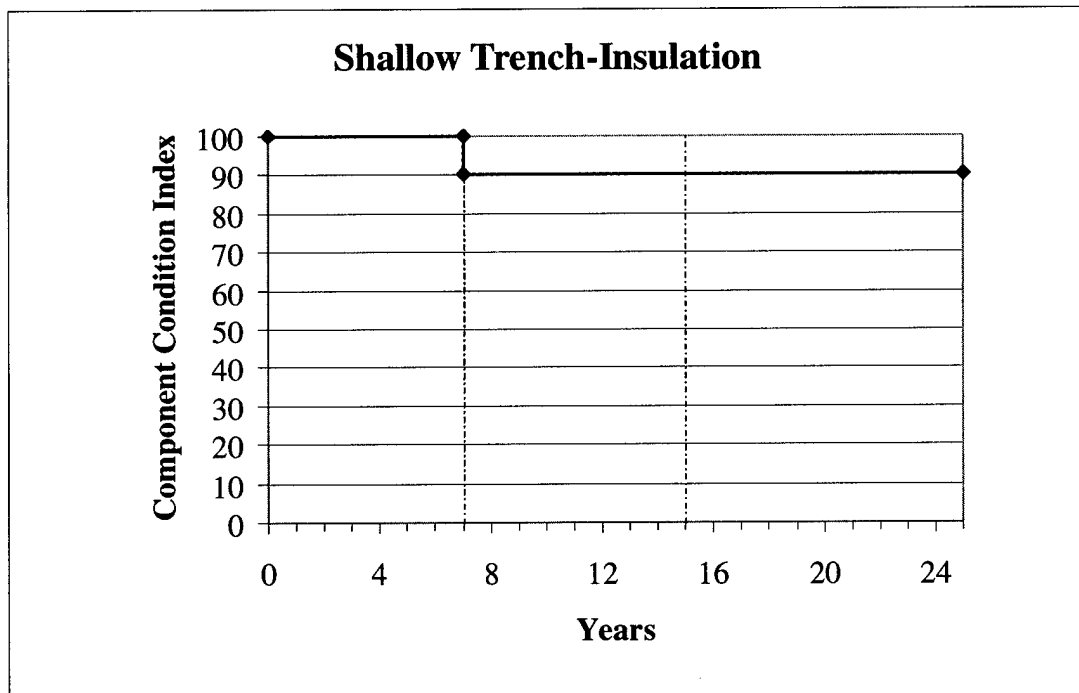
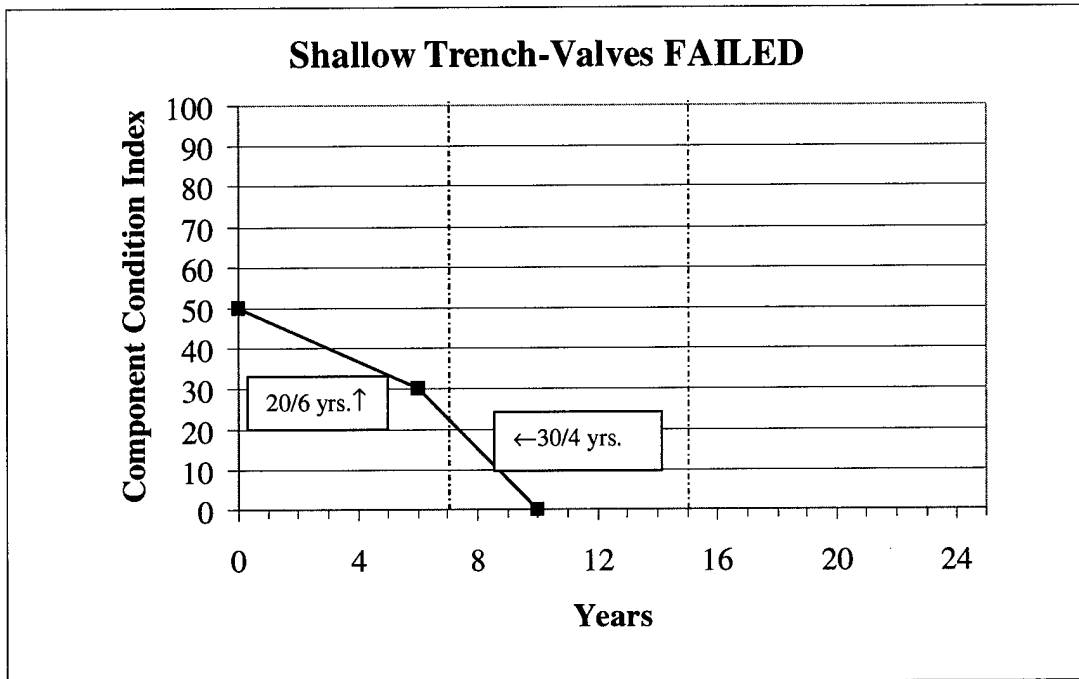

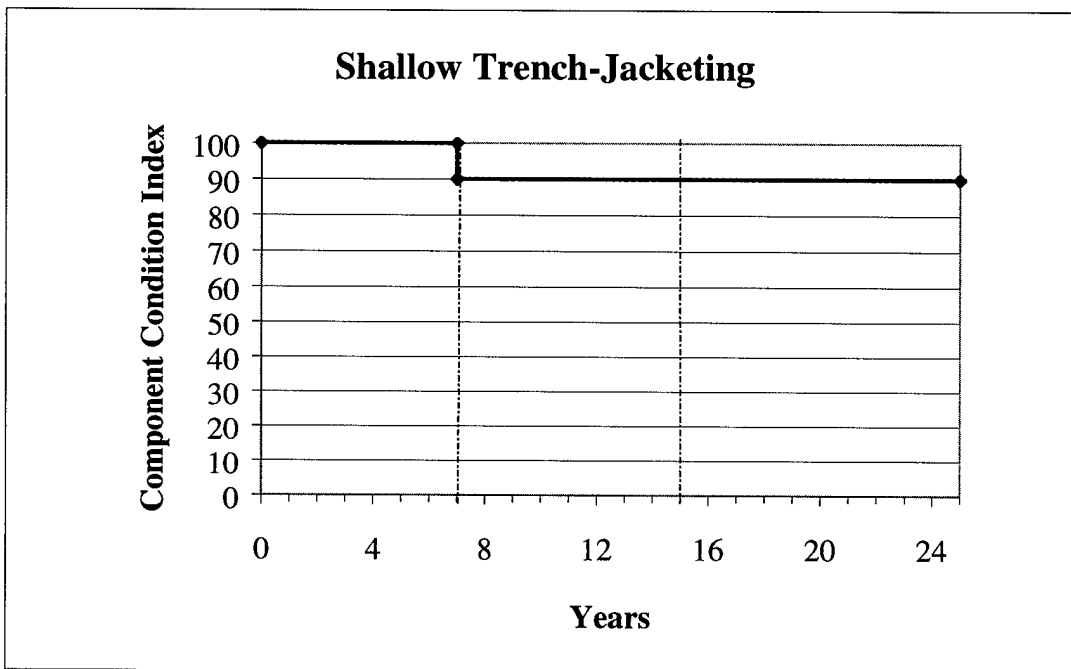
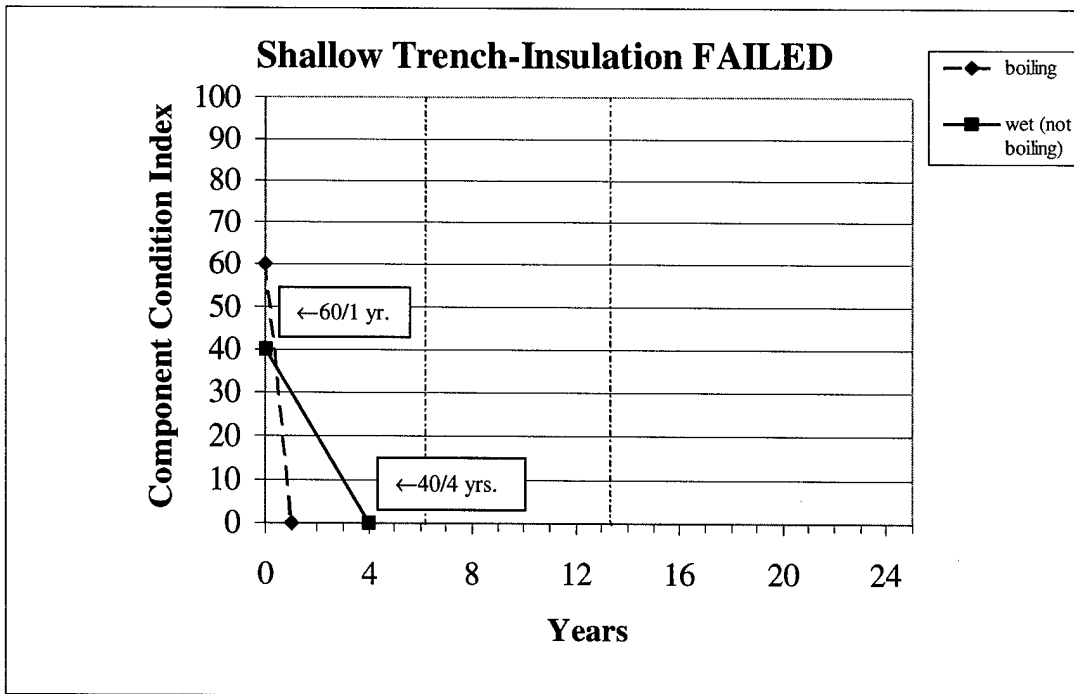

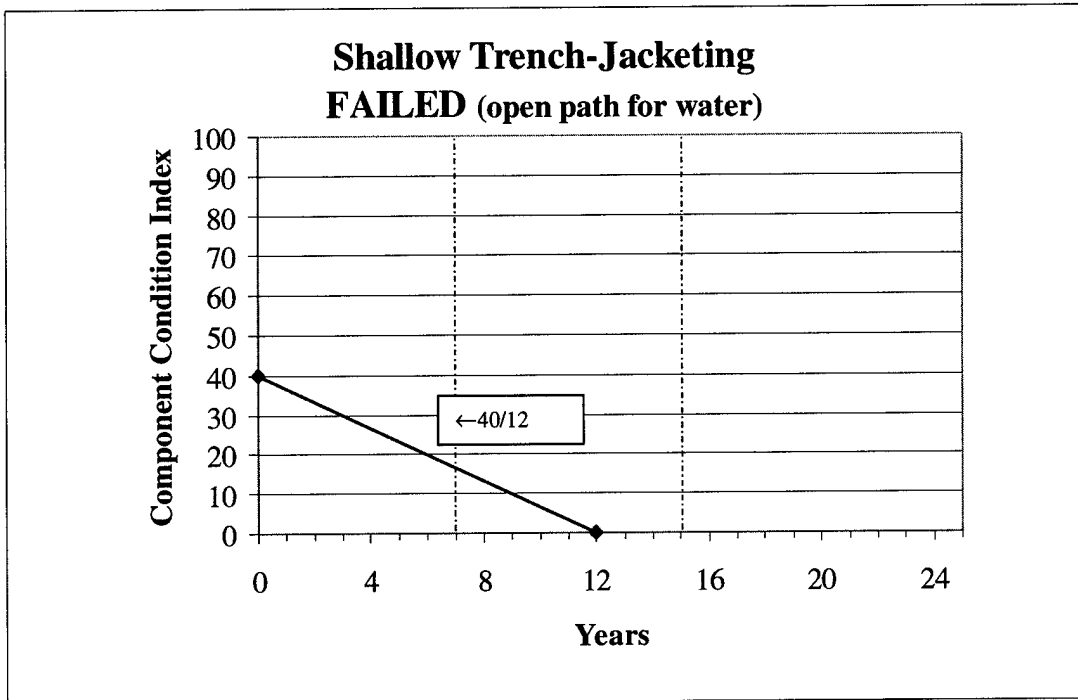

Appendix D: Pipe Corrosion Equations

The SCALER indices* were developed for use with a predictive software package that determined the amount of time to have the onset of either corrosive pitting or blockage due to scale for a percentage of original flow capacity. The SCALER predictions are typically only applicable to water in piping. Additionally, for the corrosion aspects the piping must be a ferrous metal. Inputs for the model include the water's temperature, the Ryznar Stability Index and scale thickness needed to block a fixed percentage of flow.

The Ryznar Stability Index (RI) is used to predict the scaling or corrosive tendencies of a particular water. The RI is calculated by subtracting the actual pH of the water from twice its saturation pH (pH_s), or,

$$\text{RI} = 2 \text{pH}_s - \text{pH}$$

The saturation pH is defined as the pH at which the water is saturated with calcium carbonate (CaCO_3) in solution, and is calculated by,

$$\text{pH}_s = A + B - \log(\text{Ca}) - \log(\text{Alk})$$

where A and B are standard listed constants and Ca and alkalinity (i.e., Alk) are expressed in ppm of CaCO_3 . Various ranges of RI correspond to the general scaling or corrosion tendencies listed in Table D1.

* V.L. Van Blaricum, R.H. Knoll, V.F. Hock, and J.R. Myers, "SCALER Engineered Management System for Internal Potable Water Piping," paper number 176, Corrosion90 conference, Las Vegas, NV, 23 - 27 April 1990, National Association of Corrosion Engineers (NACE).

Table D1. A water's scale/corrosion tendency according to Ryznar Index values.

RI Range	Scale/Corrosion Tendency
4.0 to 5.0	Heavy scale
5.0 to 6.0	Light scale
6.0 to 7.0	Little scale or corrosion
7.0 to 7.5	Significant corrosion
7.5 to 9.0	Heavy corrosion
9.0 or higher	Very heavy corrosion

It was found that for RI values above 7.0 the time to initiate pitting in a pipe could be described in two regimes depending on water temperature. For temperatures above 140 °F* the time, T(yrs), for leakage is given by,

$$T = [P / 0.0261 (RI - 7)]^3$$

where P is the pipe wall thickness as measured in inches. For temperatures at or below 140 °F the time, T(yrs), for leakage is given by,

$$T = [P / 0.02 (RI - 7.0)]^3 = T$$

Alternatively the time for corrosion of less then the entire wall thickness can also be calculated.

For RI values of 7.0 or less, the scaling regime, there is again a difference according to temperature. For temperatures at or below 140 °F there is essentially negligible scaling. For temperatures above 140 °F a number of factors come into play and the associated computer program returns a time, T(yrs), necessary to arrive at a certain thickness of scale resulting in some percentage of reduced flow, including full blockage.

* °F = (°C x 1.8) + 32

CERL Distribution

Chief of Engineers
ATTN: CEHEC-IM-LH (2)
ATTN: CEMP-ET

Engineer Research and Development Center (Libraries)
ATTN: ERDC, Vicksburg, MS
ATTN: Cold Regions Research, Hanover, NH
ATTN: Topographic Engineering Center, Alexandria, VA

Defense Tech Info Center 22304
ATTN: DTIC-O

7
6/01

REPORT DOCUMENTATION PAGE

Form Approved
OMB No. 0704-0188

Public reporting burden for this collection of information is estimated to average 1 hour per response, including the time for reviewing instructions, searching existing data sources, gathering and maintaining the data needed, and completing and reviewing the collection of information. Send comments regarding this burden estimate or any other aspect of this collection of information, including suggestions for reducing this burden, to Washington Headquarters Services, Directorate for Information Operations and Reports, 1215 Jefferson Davis Highway, Suite 1204, Arlington, VA 22202-4302, and to the Office of

1. AGENCY USE ONLY (Leave Blank)		2. REPORT DATE July 2001	3. REPORT TYPE AND DATES COVERED Final		
4. TITLE AND SUBTITLE Condition Prediction Model and Component Interaction Fault Tree for Heat Distribution Systems			5. FUNDING NUMBERS 4A162784AT41 Work Unit GC9		
6. AUTHOR(S) Charles P. Marsh, Brian A. Temple, and Angela Kim					
7. PERFORMING ORGANIZATION NAME(S) AND ADDRESS(ES) Construction Engineering Research Laboratory (CERL) P.O. Box 9005 Champaign, IL 61826-9005			8. PERFORMING ORGANIZATION REPORT NUMBER ERDC/CERL TR-01-35		
9. SPONSORING / MONITORING AGENCY NAME(S) AND ADDRESS(ES) U.S. Army Corps of Engineers ATTN: CECW-ET 441 G Street NW Washington, DC 20314			10. SPONSORING / MONITORING AGENCY REPORT NUMBER		
9. SUPPLEMENTARY NOTES Copies are available from the National Technical Information Service, 5385 Port Royal Road, Springfield, VA 22161					
12a. DISTRIBUTION / AVAILABILITY STATEMENT Approved for public release; distribution is unlimited.			12b. DISTRIBUTION CODE		
13. ABSTRACT (Maximum 200 words) <p>Predictive maintenance of heat distribution systems (HDSs) is highly desirable, but very difficult to cost-effectively execute. Frequent, detailed inspection is largely impractical, and components are subject to complex, obscure interdependencies that can create seemingly unrelated distresses virtually anywhere in the system. An Engineered Management System (EMS) called HEATER is being developed to give Army utility managers a set of repeatable, inspection-based tools to enhance HDS operation and maintenance programs. Inclusion of a condition prediction function in HEATER would be a great asset for planning and cost-optimizing scenario-based preventive maintenance.</p> <p>The objective of the current study was to develop a practical condition prediction method for incorporation into HEATER. The resulting method introduces two new tools: (1) a component interaction fault tree, which accounts for all HDS components and their major interdependencies, and (2) a condition index (CI) tree, which assigns weights to various components according to their level of impact on overall system condition. Inspection data are to be processed through the fault tree, then mapped into the EMS via the CI tree. The resulting EMS output is expected to support scenario-based condition prediction that is significantly more reliable than could be achieved through manual tracking of the separate system components.</p>					
14. SUBJECT TERMS operation and maintenance predictive maintenance			heat distribution systems Engineered Management System (EMS)	HEATER condition rating	15. NUMBER OF PAGES 109
					16. PRICE CODE
17. SECURITY CLASSIFICATION OF REPORT Unclassified	18. SECURITY CLASSIFICATION OF THIS PAGE Unclassified	19. SECURITY CLASSIFICATION OF ABSTRACT Unclassified	20. LIMITATION OF ABSTRACT SAR		