

Radiation Test on a Small DC-DC Converter

20 February 2001

Prepared by

C. H. TRUONG,¹ K. SIRI,² E. J. SIMBURGER,¹ R. C. LACOE,¹
J. C. ROSS,¹ S. BROWN,¹ and A. PRATER¹

¹Electronics and Photonics Laboratory
Laboratory Operations

²Electronics Engineering Subdivision
Electronic Systems Division

Prepared for

SPACE AND MISSILE SYSTEMS CENTER
AIR FORCE MATERIEL COMMAND
2430 E. El Segundo Boulevard
Los Angeles Air Force Base, CA 90245

20010808 078

Engineering and Technology Group

APPROVED FOR PUBLIC RELEASE;
DISTRIBUTION UNLIMITED

This report was submitted by The Aerospace Corporation, El Segundo, CA 90245-4691, under Contract No. F04701-00-C-0009 with the Space and Missile Systems Center, 2430 E. El Segundo Blvd., Los Angeles Air Force Base, CA 90245. It was reviewed and approved for The Aerospace Corporation by B. Jadaszliwer, Principal Director, Electronics and Photonics Laboratory; and A. D. Yarbrough, Principal Director, Electrical & Electronics Systems Department. Michael Zambrana was the project officer for the Mission-Oriented Investigation and Experimentation (MOIE) program.

This report has been reviewed by the Public Affairs Office (PAS) and is releasable to the National Technical Information Service (NTIS). At NTIS, it will be available to the general public, including foreign nationals.

This technical report has been reviewed and is approved for publication. Publication of this report does not constitute Air Force approval of the report's findings or conclusions. It is published only for the exchange and stimulation of ideas.

A handwritten signature in cursive script, reading "Michael S. Zambrana". The signature is written in black ink and is positioned above a horizontal line.

Michael Zambrana
SMC/AXE

REPORT DOCUMENTATION PAGE

Form Approved
OMB No. 0704-0188

Public reporting burden for this collection of information is estimated to average 1 hour per response, including the time for reviewing instructions, searching existing data sources, gathering and maintaining the data needed, and completing and reviewing the collection of information. Send comments regarding this burden estimate or any other aspect of this collection of information, including suggestions for reducing this burden to Washington Headquarters Services, Directorate for Information Operations and Reports, 1215 Jefferson Davis Highway, Suite 1204, Arlington, VA 22202-4302, and to the Office of Management and Budget, Paperwork Reduction Project (0704-0188), Washington, DC 20503.

1. AGENCY USE ONLY (Leave blank)		2. REPORT DATE 20 February 2001		3. REPORT TYPE AND DATES COVERED	
4. TITLE AND SUBTITLE Radiation Test on a Small DC-DC Converter			5. FUNDING NUMBERS F04701-00-C-0009		
6. AUTHOR(S) C. H. Truong, K. Siri, E. J. Simburger, R. C. Lacoce, J. C. Ross, S. Brown, and A. Prater					
7. PERFORMING ORGANIZATION NAME(S) AND ADDRESS(ES) The Aerospace Corporation Laboratory Operations El Segundo, CA 90245-4691			8. PERFORMING ORGANIZATION REPORT NUMBER TR-2001(8555)-5		
9. SPONSORING/MONITORING AGENCY NAME(S) AND ADDRESS(ES) Space and Missile Systems Center Air Force Materiel Command 2430 E. El Segundo Boulevard Los Angeles Air Force Base, CA 90245			10. SPONSORING/MONITORING AGENCY REPORT NUMBER SMC-TR-01-15		
11. SUPPLEMENTARY NOTES					
12a. DISTRIBUTION/AVAILABILITY STATEMENT Approved for public release; distribution unlimited				12b. DISTRIBUTION CODE	
13. ABSTRACT (<i>Maximum 200 words</i>) <p>This report presents the approach to and results of the total dose and dose rate testing on a typical low-power dc-dc converter used in cellular phones, beepers, and other portable devices. The dc-dc power converter under test will be employed to convert the unregulated battery voltage to a regulated 5-V bus in the power system of the PowerSphere power management architecture for micro- and nano-satellites and the Pico-2 picosatellites currently under development by The Aerospace Corporation. The purpose of the test was to characterize the performance of the converter under radiation effects, as well as to determine the level of total dose tolerance at which the converter's performance starts deteriorating. The electrical measurements, focused on key parameters such as regulation control, ripple, and efficiency of the converter, were performed at several levels of total dose up to 100 krad(Si). Performance degradation of the dc-dc converters caused by irradiation effect was analyzed. The irradiation test was performed at both high and low dose rates to evaluate the dose-rate sensitivity of the device. The result of the test was also presented to the Government Microcircuit Application Conference (GOMAC 2001) at San Antonio, Texas, USA, in March 3-8, 2001.</p>					
14. SUBJECT TERMS DC-DC converter, total dose tolerance, dose-rate effects, power converter, irradiation effect				15. NUMBER OF PAGES 19	
17. SECURITY CLASSIFICATION OF REPORT UNCLASSIFIED				16. PRICE CODE	
				20. LIMITATION OF ABSTRACT	
18. SECURITY CLASSIFICATION OF THIS PAGE UNCLASSIFIED		19. SECURITY CLASSIFICATION OF ABSTRACT UNCLASSIFIED		20. LIMITATION OF ABSTRACT	

Acknowledgements

This work was supported by the U.S. Air Force Space and Missile Center under Contract No. F04701-93-C-0094. The authors would like to thank Lester Byington, Richard Mahoney, Jon Osborn, and David Scott of The Aerospace Corporation for technical discussions.

Contents

1. Introduction.....	1
2. Architecture of the DC-DC Converter.....	3
3. Test Description.....	5
4. Test Result.....	7
4.1 Output Voltage	7
4.2 Efficiency.....	9
4.3 Minimum Startup Voltage	11
4.4 Leakage Current	11
4.5 Load Regulation	12
4.6 Line Regulation	12
4.7 Output Voltage Ripple	13
4.8 Step Load Overshoot and Undershoot.....	14
5. Conclusions.....	15
6. Future Work	17
References.....	19

Figures

1. PowerSphere concept and PicoSat.....	1
2. Maxim dc-dc converters under test.....	3
3. Cobalt 60 with the five samples.....	5
4. Irradiation chamber and measurement station.	5
5. Two bias configurations: Power Off and Power On.....	6
6. Output voltage at light load.....	7

7. Output voltage at mid load.	8
8. Output voltage for high input voltage.	8
9. Efficiency at light load.....	9
10. Efficiency at mid load.....	10
11. Efficiency at high input voltage.....	10
12. Minimum startup voltage.....	11
13. Leakage current.....	11
14. Load regulation.	12
15. Line regulation.	13
16. Output ripple.	13
17. Step load overshoot.....	14
18. Step load undershoot.....	14

Table

1. Test Setup Summary.....	6
----------------------------	---

1. Introduction

Small dc-dc converters are used widely in portable devices to convert unregulated battery voltage to a regulated voltage for the main load. These converters are also being employed in small satellite power systems due to their small size and low mass. Among various types of low-voltage and low-power dc-dc converters, the Max 1676, made by Maxim Integrated Products, was selected as the step-up converters to convert power from energy source and storage systems to a regulated 5-V power bus for small satellites such as PowerSphere and PicoSAT as shown in Figure 1. The PowerSphere concept is intended for micro- and nano-satellites, while the PicoSAT is dedicated for picosatellites below one pound. A similar Maxim converter, Max 710, was used in the first successful Pico-1 flight experiment hosted by the OPAL satellite and currently in the second PicoSAT flight Pico-1.1 onboard the Mightysat II.1 host spacecraft slated for release in July 2001. The Max 1676 will be used in the PicoSAT 2 power system for converting battery voltage to a 5-V power bus. To determine the total dose tolerance of the converter in the space environment, a radiation evaluation was performed on samples of this device. The evaluation was based on several electrical measurements made during the irradiation. The measurements emphasized steady-state performance such as line and load regulation, output voltage ripple, and efficiency, as well as the converter's dynamic performance due to step-line and step-load transitions. Since dose-rate effects depend on the types of devices and processing¹ for some devices, the space data compare favorably to the low dose-rate data.² Dose-rate sensitivity of this converter, however, also needs to be determined.

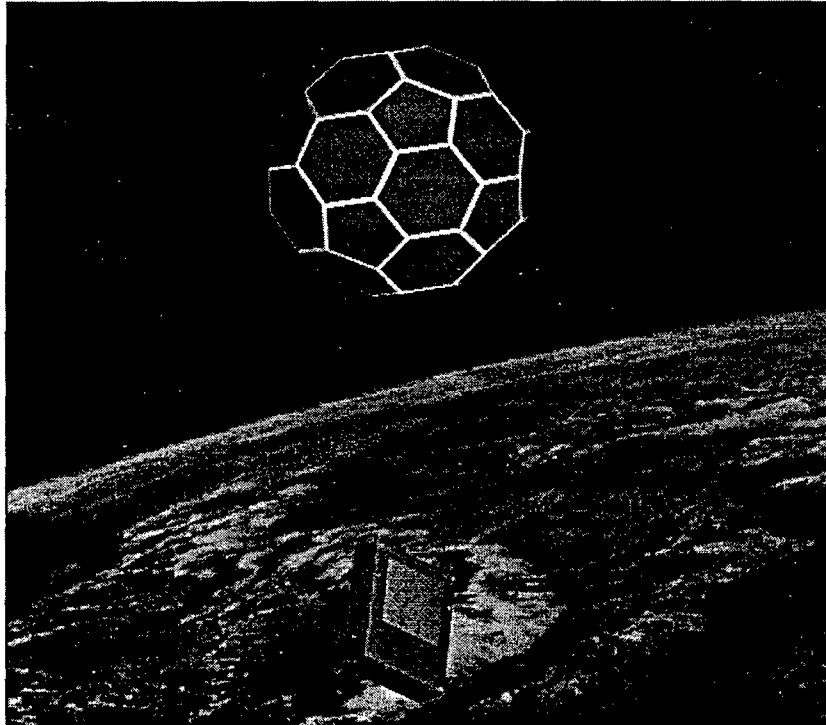

Figure 1. PowerSphere concept and PicoSat.

2. Architecture of the DC-DC Converter

The step-up Maxim dc-dc converters used in the testing employ conventional boost dc-dc topology with synchronous rectification that eliminates the need for an external Schottky diode. The main converter chip is composed of the power stage and control. It is compact and fits in a small package that has the same footprint as an SMT 8-pin as shown in Figure 2. In addition, only one inductor and three capacitors are needed as a minimum to form the step-up converter. According to the data sheet, typical efficiency for 5-V output regulation is 90%. Each converter can start up with voltages as low as 0.9 V and operate down to 0.7 V at light load.

In each converter, one p-channel MOSFET is used as a synchronous rectifier, and one n-channel MOSFET is used as a controlled switch for boosting the output voltage above the input voltage. The converter switching frequency depends on the load and input voltage, and can range up to 500 kHz. The feature of input-current limiting ensures that the output-voltage ripple does not exceed the product of the switch current limit and the filter-capacitor equivalent series resistance (ESR). The converter also provides a +1.3-V reference voltage that can source up to 100 μ A to external circuits. In applications where electromagnetic interference is critical, an internal damping switch can be optionally used with an external damping resistor to minimize the high-frequency ringing superimposed on the output voltage.

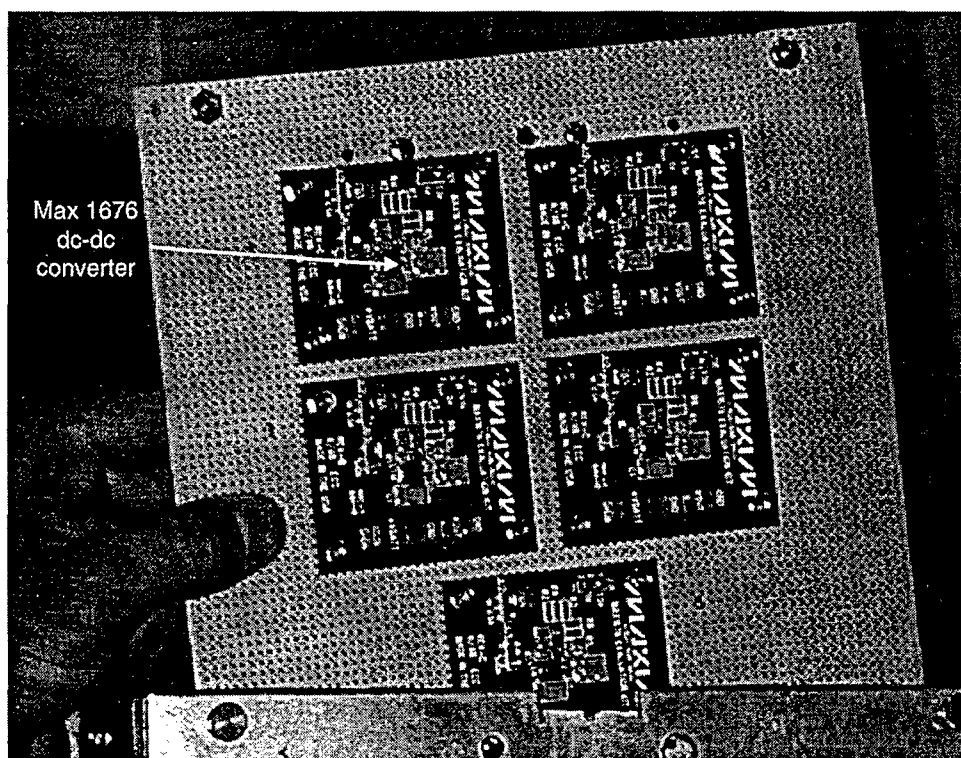

Figure 2. Maxim dc-dc converters under test.

3. Test Description

The total dose radiation test was performed using a Cobalt 60 gamma-ray source in a test facility at The Aerospace Corporation. Figures 3 and 4 show the Co 60 model 484 series irradiation facility at building A6 of Laboratory Operations. In the Co 60 there are four sources providing overlapping dose rates from below 1 rad(Si)/h up to 3,500,000 rad(Si)/h.

During the irradiation testing, two bias configurations were applied. The first bias configuration was power-off with all input and output pins of the samples connected together. This configuration correlates with the mission plan of the PicoSAT 1.1. The tiny satellite will be mounting on the MightySat 2.1 host spacecraft without power-on for one year before the release is activated. The converter in the second bias configuration was powered on with a power supply connected at the input and an electronic load drawing a programmable constant current load at the output. Figure 5 shows the two bias configurations.

The total dose radiation levels were 2.5, 5.0, 7.5, 10.0, 12.5, 15.0, 20.0, 30.0, 50.0, and 100.0 krad(Si). At each total dose level, electrical measurements were made on samples under test to record the response of the converter at different input voltages and load conditions. Data for current and voltage at the input and output of the dc-dc converter under various line voltages and load conditions were collected at the end of each level of total-dose irradiation. Performance parameters such as efficiency, output-voltage ripple, minimum start-up input voltage, and overshoot and undershoot during step-load transitions were used to assess the degradation in regulation control and transient suppression capability of the device.

Three sequences of total dose test were performed. The first total dose test sequence was performed at a high dose rate of 5.73 rad(Si)/s and power-off bias condition for one sample. The second total dose test sequence was performed at a low dose rate of 0.01156 rad(Si)/s and power-off bias condition for five samples. The low dose rate test result presented is the average of the results of five samples with standard deviation error bars. From 50 krad to 100 krad, a slightly raised low dose-rate

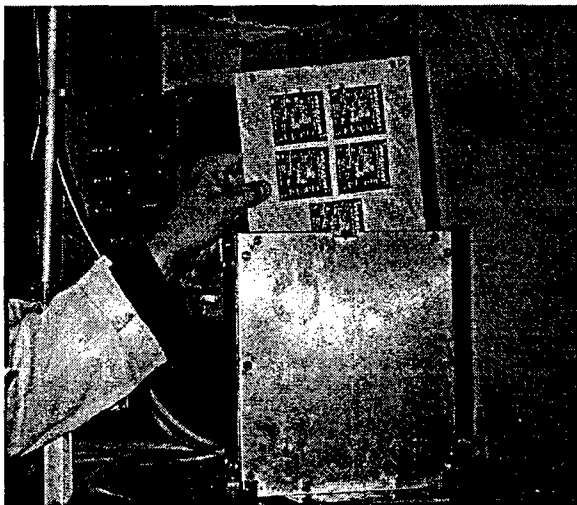

Figure 3. Cobalt 60 with the five samples.

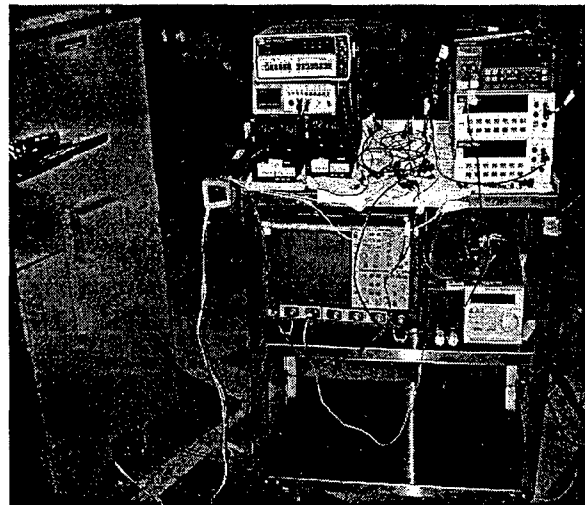

Figure 4. Irradiation chamber and measurement station.

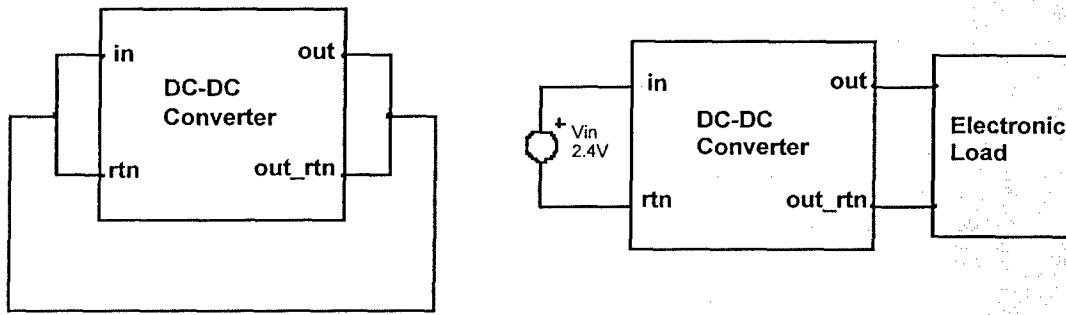

Figure 5. Two bias configurations: Power Off and Power On.

of 0.01929 rad(Si)/s was applied to speed up the test. Finally, the third total dose test sequence was performed at a high dose rate of 5.73 rad(Si)/s and power-on bias condition for two samples. One of the two samples failed between the total dose of 50 and 100 krad levels. The test setup is summarized in Table 1. Effective dose rate for each sequence was also calculated by including the electrical measurement time.

Table 1. Test Setup Summary

Test Sequence	Total Dose krad(Si)	Dose Rate rad/s	Effective Dose Rate rad/s	Bias Condition	Number of Samples	Duration	Result
1	100	High 15	5.73	Power Off	1	5 Hours	Functional
2	100	Low 0.01156 0.01929	0.01337	Power Off	5	87 Days	Functional
3	100	High 15	5.24	Power On	2	5 Hours	1 failed, 1 functional

4. Test Result

Like other commercial parts, the Max 1676 converter was not purely built for space applications. Most of the test results here are compared to the data of the initial measurement at the beginning of the test and the specification limit to evaluate the irradiation sensitivity and tolerance of the device. Also, dose-rate sensitivity is discussed based on the results of high and low dose rate tests. All three sequences of total dose test were completed at the total dose level of 100 krad.

4.1 Output Voltage

The manufacturer's specification on the output voltage is the range between 4.8 and 5.2 V. The converters performed very well in regulation control during the power-off high dose rate test as shown in Figure 6. The output voltage was regulated at around 5 V through the 100-krad total dose irradiation. However, during the low dose rate test, at the 10 krad level, two (out of five) samples lost regulation control because their output voltage was significantly load dependent and not well regulated, but later they were able to recover the regulation control and operated through the end of the test. Moreover, irradiation at low dose rate resulted in an increase in the nominal regulated voltage of the device as compared to the results at the high dose rate. In this case, the output voltage increased to 6 V as the total dose reached 100 krad, well exceeding the 5.2-V maximum voltage specification for normal operation. In the case of power-on at high dose rate, similar increasing output voltage was observed.

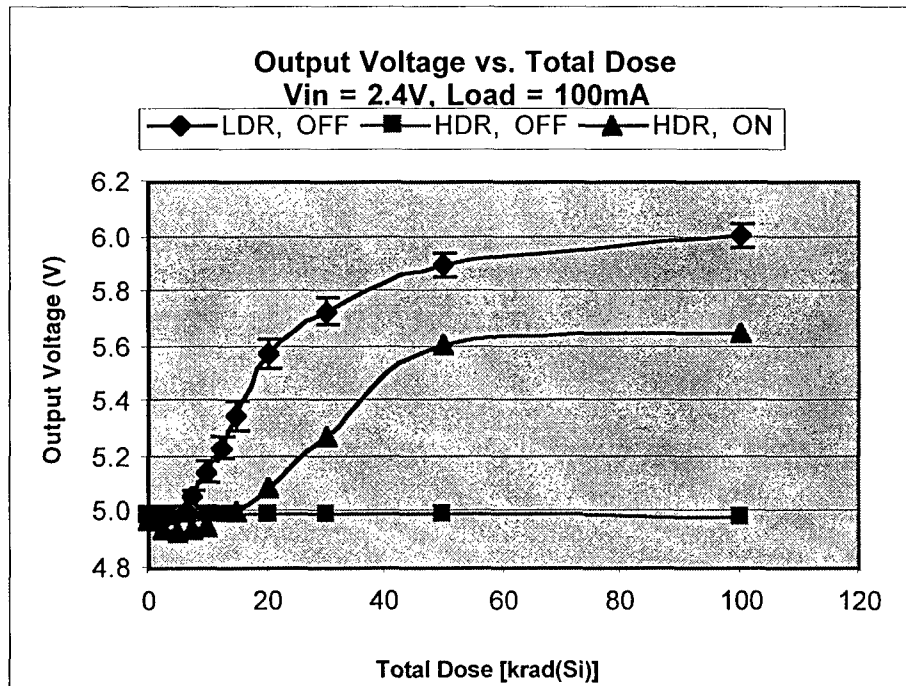

Figure 6. Output voltage at light load.

Output voltage data was also collected for other cases such as mid load and high input voltage. As shown in Figures 7 for the case of 200mA load, the regulated output voltage was drifted down to a lower level instead of drifting to a higher regulated voltage like the case of high input in Figure 8. Radiation effect on the reference circuit was a dominant factor in this result.

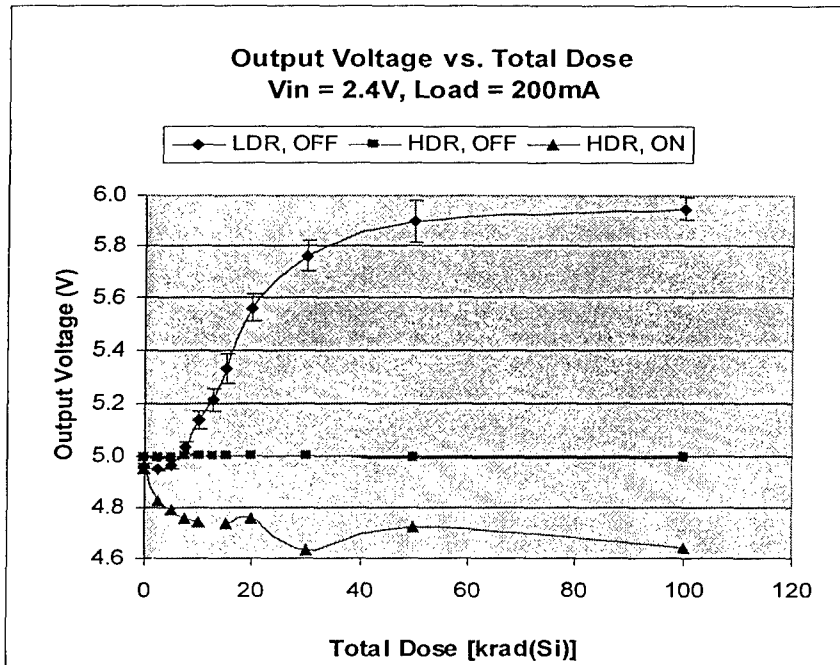

Figure 7. Output voltage at mid load.

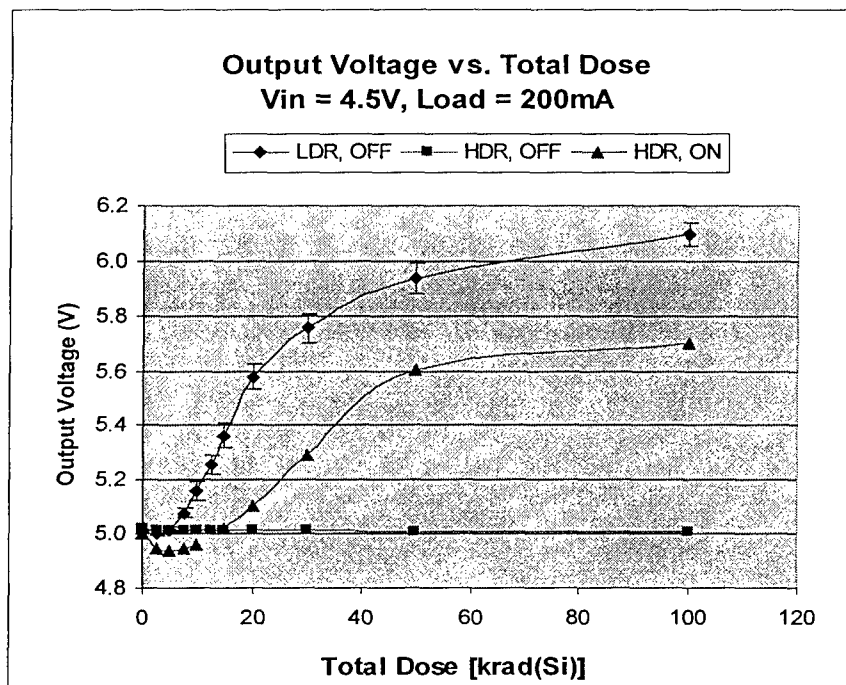

Figure 8. Output voltage for high input voltage.

4.2 Efficiency

From the measurement data, the efficiency of the converter at various load conditions and input voltages was derived for comparisons. As shown in Figure 9, at the light load condition, efficiency stayed in the range of 78% to 86% for both low and high dose rates at power-off condition. Degradation caused by the irradiation effect was not significant. Similar effect was observed in the case of power-on, the efficiency dropped only 6% from 82 to 76%.

At mid load condition, the effect was higher, as shown in Figure 10. In the power-off condition, radiation effect caused a 6 % drop in the case of high dose rate. Due to the abrupt increase of the input current, the degradation reduced the efficiency to 48% at low dose rate, significantly lower than the 74% at the beginning of irradiation. Also, in the power-on condition, the efficiency dropped to 36%. Thus, at full load condition, the converters degraded faster than at the light load condition.

At the higher input voltage of 4.5 V, the input current increased in a slower pace during the irradiation. Therefore, the converter efficiency was maintained within the range of 85 to 90% for all cases, as shown in Figure 11. The fact that converters can achieve higher efficiency at high input voltage condition is a normal characteristic, and the test result further indicates that this characteristic is quite independent from irradiation effects. This result pinpoints a favorable operating zone for defining system requirements.

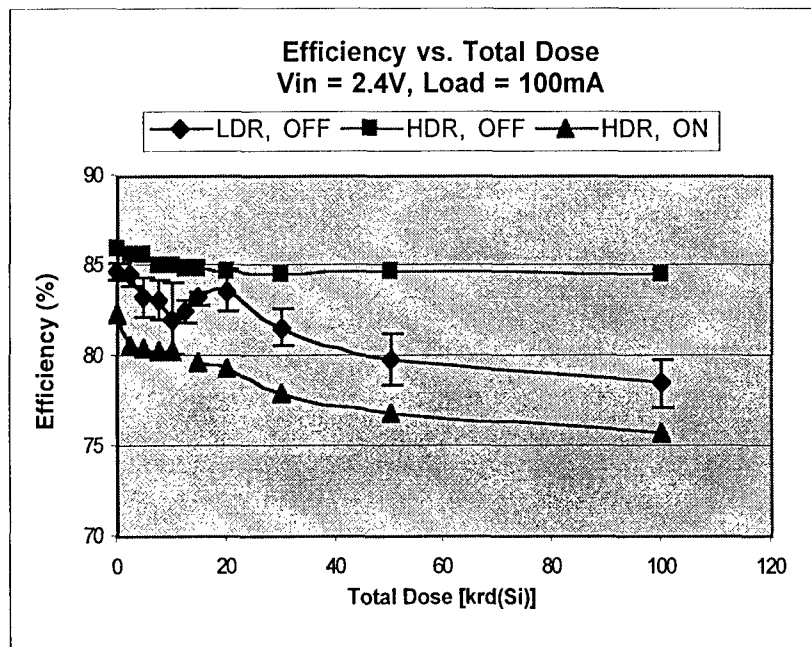

Figure 9. Efficiency at light load.

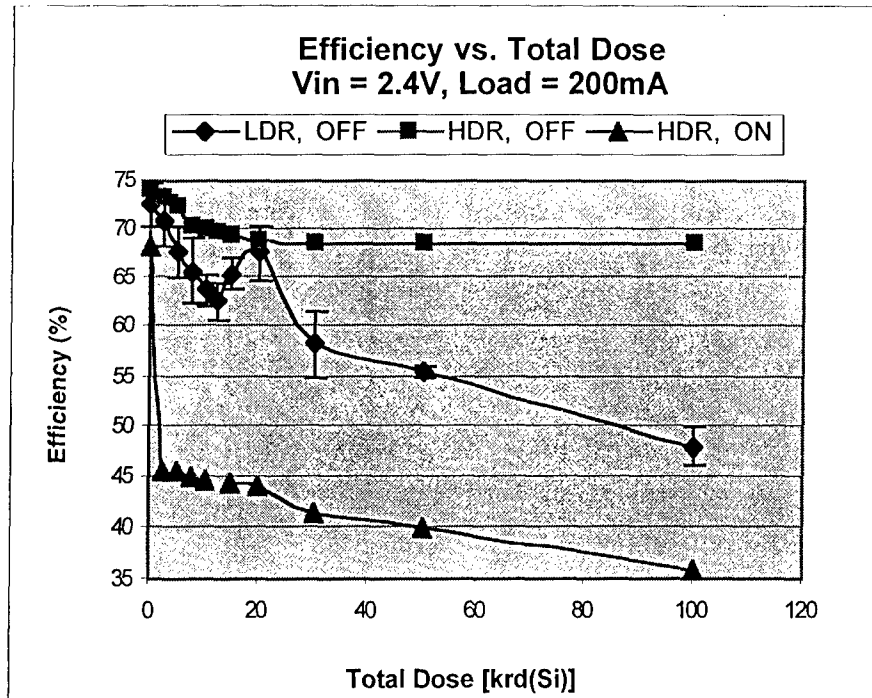

Figure 10. Efficiency at mid load.

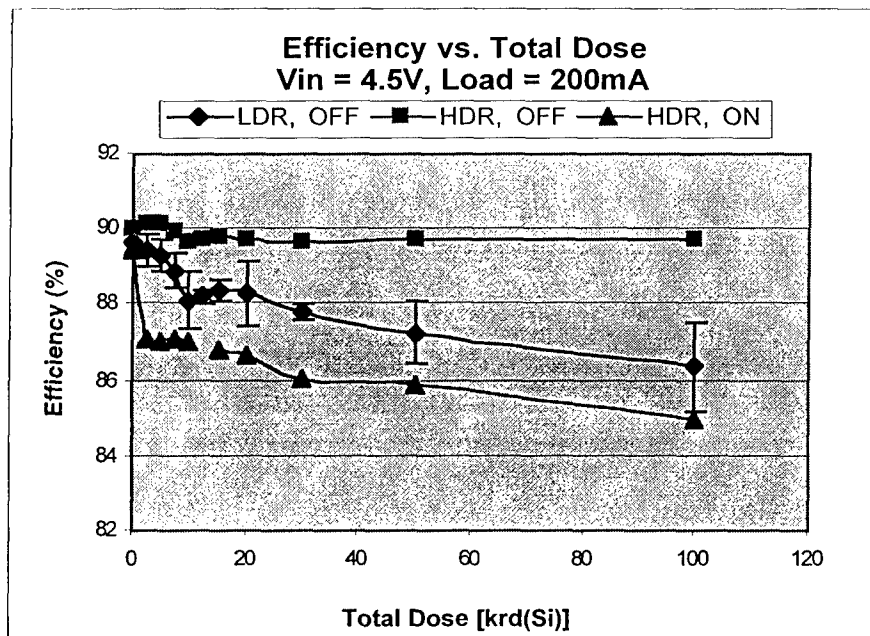

Figure 11. Efficiency at high input voltage.

4.3 Minimum Startup Voltage

The minimum voltage to start up the converters was measured at light load (100 mA) condition. As shown in Figure 12, at power-off condition, the Max 1676 converters required only 1.5 to 1.6 V to start up, and the performance was quite consistent and not changed by total dose effects. Similar constant response was observed at the case of power-on condition. Only the leakage current stayed at a slightly higher range (1.70 V to 1.75 V).

4.4 Leakage Current

Also known as no-load input current, the leakage current was measured at 2.4 V input. The measurement shows that the test at a high dose rate caused greater slope on the increasing leakage current at the beginning than the test at low dose rate. As shown in Figure 13, the leakage current measured

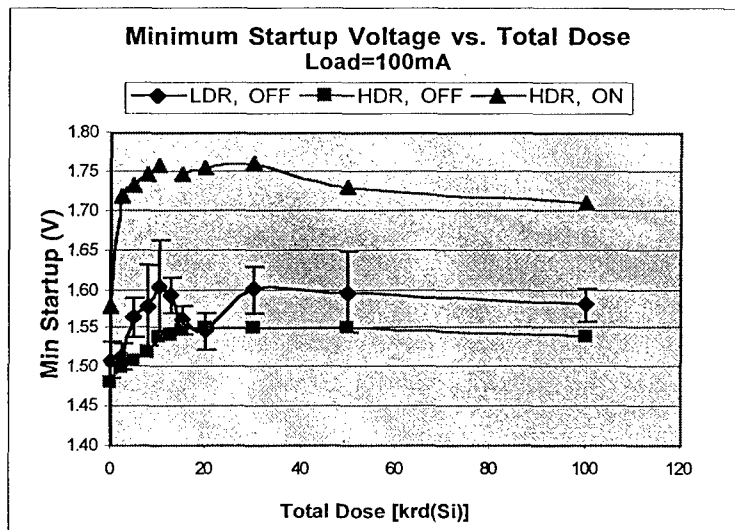

Figure 12. Minimum startup voltage.

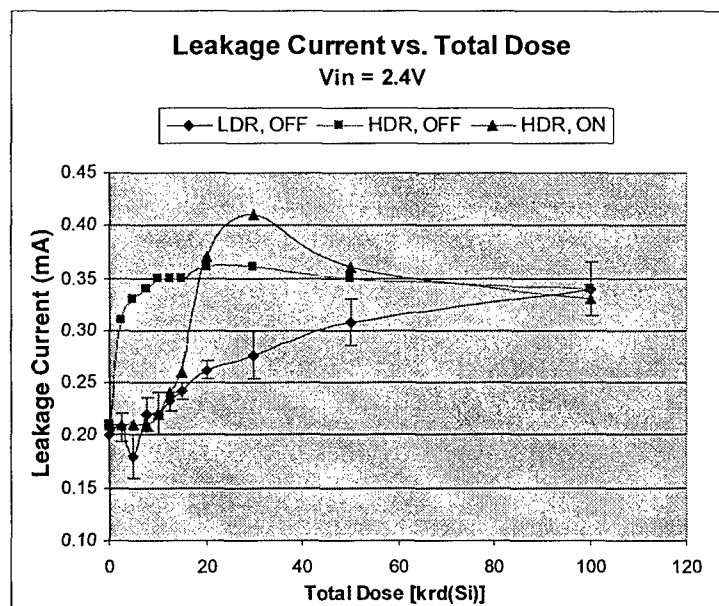

Figure 13. Leakage current

at high dose rates was around 0.35 mA, while at low dose rates the leakage current was in the range from 0.2 to 0.3 mA. However, when approaching 100 krad, all cases merged to the 0.35-mA level. Most of the data appear higher than the manufacturer's specification limit. Sufficient margin should be reserved when allocating power budget for the device at no-load condition since the converter consumed 0.84 mW at no-load condition.

4.5 Load Regulation

Load regulation was the difference between the output voltage response from no load to 200 mA load conditions measured at 2.4-V input. As shown in Figure 14, at power off condition, measurement results show that at high dose rate, the load regulation stayed within 20 mV and had almost no effects from irradiation. At low dose rate, the load regulation increased to 100 mV (less than 2% of output voltage) when the total dose reached 100 krad. The result is favorable since the load current change did not seem to cause significant impact to the output regulation control even operating in irradiated condition. However, at power-on condition, load regulation increased in the same pace with the trend of the output voltage itself.

4.6 Line Regulation

Line regulation was derived from the difference of the output voltage response at full load when input voltage changed from 2.4 to 4.5V. As shown in Figure 15, similar to the result of load regulation, line regulation at high dose rate stayed around 18 mV, and at the low dose rate test, it varied between 50 and 10 mV. The line voltage change did not cause significant impact to the regulation control under irradiation. Similar to the result of load regulation, at power-on condition, line regulation increased with the output voltage as the total dose was accumulated. The output voltage drift-up is a limitation of the chip caused by the radiation effect at the reference voltage circuit. The problem could be corrected by an additional circuit.

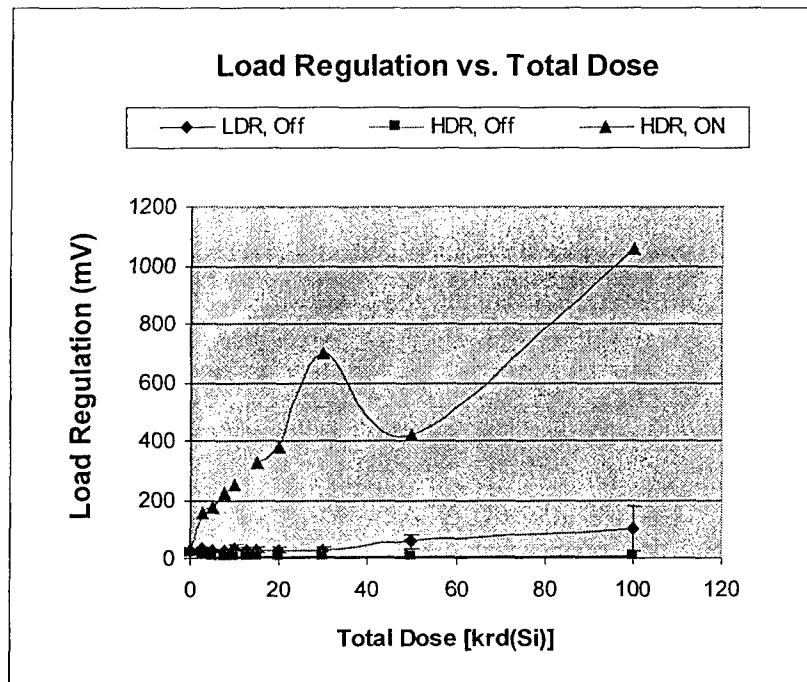

Figure 14. Load regulation.

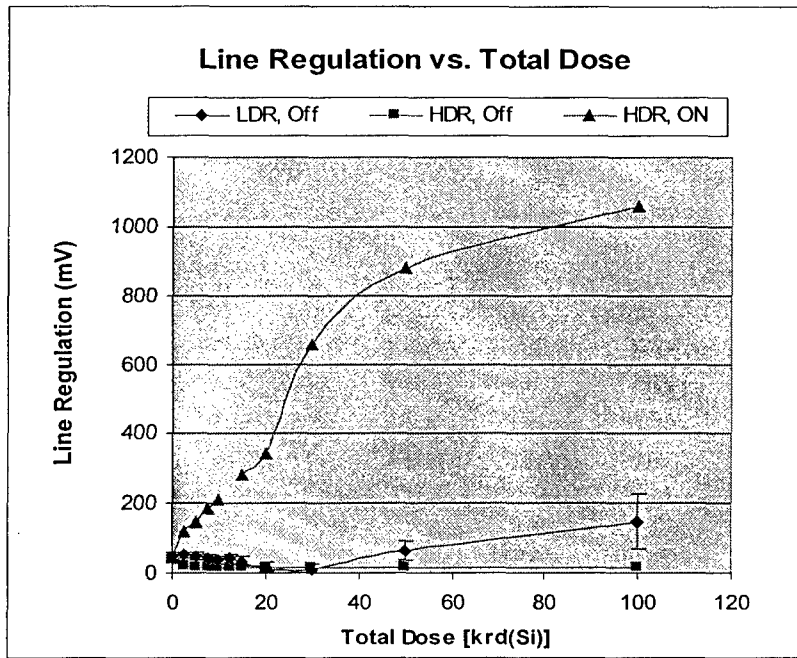

Figure 15. Line regulation.

4.7 Output Voltage Ripple

The output ripple was within 120 mV in the two test sequences: low dose rate with power off and high dose rate with power on as shown in Figure 16. At high dose rate test with power off, the ripple declined from 200 mV to 120 mV as the total dose accumulated. At 100 krad, ripple voltages for all three test series were within 140 mV. Radiation seemed to have little effect on ripple voltage amplitude.

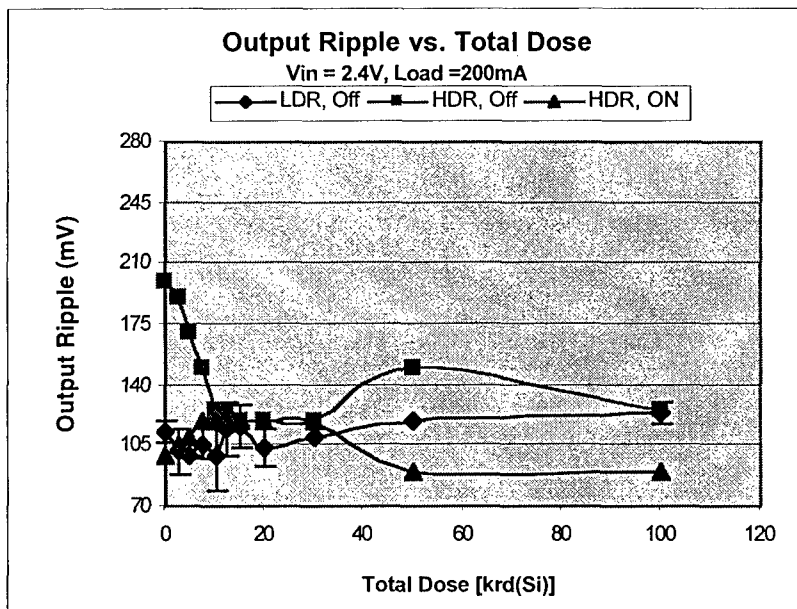

Figure 16. Output ripple.

4.8 Step Load Overshoot and Undershoot

The overshoot and undershoot magnitudes at the output voltage during step-load transition from light to mid load were measured at two test sequences: low dose rate with power off and high dose rate with power on. As shown in Figures 17 and 18, the overshoot level was within 50 mV, and the undershoot level was within 30 mV during the 100 krad total-dose irradiation. These magnitudes are within 1% of the output voltage level. Once again, the strength in regulation control design of these converters was proven

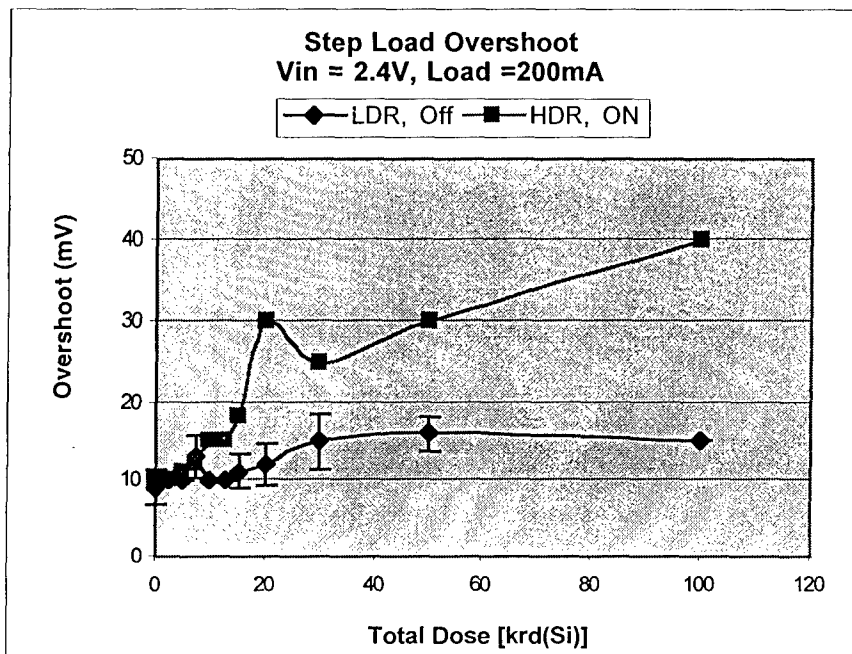

Figure 17. Step load overshoot.

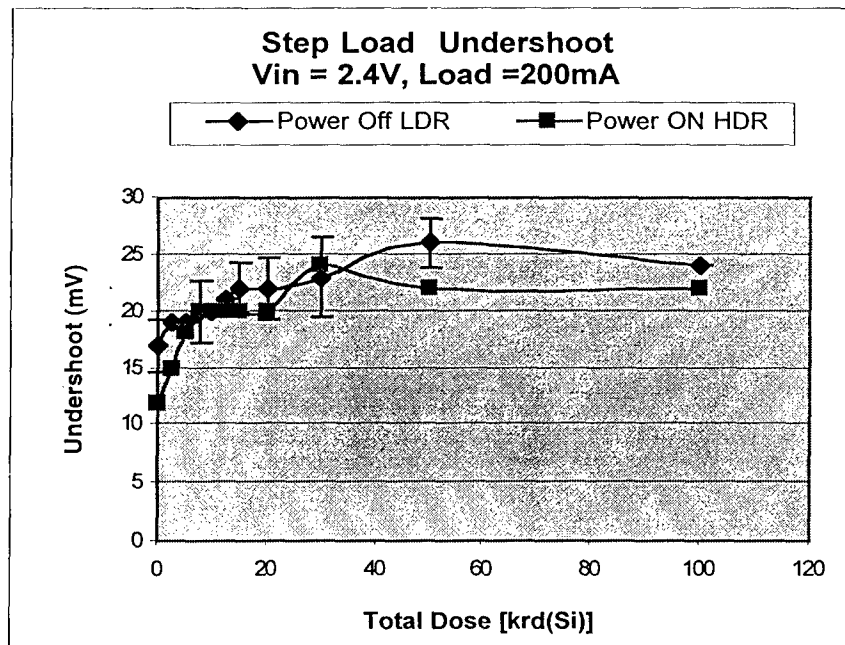

Figure 18. Step load undershoot.

5. Conclusions

Total dose test results for a typical low-voltage and low-power dc-dc converter have been discussed. The commercial device was able to function and maintain regulation control throughout the total dose irradiation at high and low dose rates. Results showed that there is little performance degradation of this converter under appropriate operating conditions. The test has verified the robust control-loop design of this popular low-cost converter from this solid performance data in regulation control. Efficiency remained over 85% and 75% at high input voltage and light load conditions, respectively, after a total dose of 100 krad (Si) was accumulated. However, the low dose-rate irradiation and the power-on bias caused severe effects at the output voltage level as it exceeded the specification significantly, and may not be acceptable to the bus requirements in some applications. This output voltage drift-up is a limitation of the chip but could be fixed by an additional circuit. Overall, the test has determined the tolerance level, sensitive parameters, and high-effect operating zones for the converter in a radiation environment. These results also provide useful information for defining requirements and configuration of the power management and distribution system for the PowerSphere and Picosat 2. Finally, this task demonstrated that testing of a highly integrated electronic device as a total system in a radiation environment can be a useful tool in determining the system level effects of radiation on system performance.

6. Future Work

Future work includes obtaining frequency response characteristics of the converter under irradiation, adding a circuit to limit the output voltage drift, and testing another low input-voltage, low power dc-dc converter made by Texas Instruments Unitrode Division. Results will be accumulated to build a radiation effect database for this type of small converters that is widely used for providing power to payloads.

References

1. A. H. Johnston, "Space Radiation Effects and Hardness Assurance for Linear Integrated Circuits," 1999 Digest of Papers, Government Microcircuit Applications Conference, Vol. XXIV, March 8-11, 1999.
2. J. L. Titus, et al., "Total Dose Response of Bipolar Devices in a Space Environment," 1999 Digest of Papers, Government Microcircuit Applications Conference, Vol. XXIV, March 8-11, 1999.

LABORATORY OPERATIONS

The Aerospace Corporation functions as an "architect-engineer" for national security programs, specializing in advanced military space systems. The Corporation's Laboratory Operations supports the effective and timely development and operation of national security systems through scientific research and the application of advanced technology. Vital to the success of the Corporation is the technical staff's wide-ranging expertise and its ability to stay abreast of new technological developments and program support issues associated with rapidly evolving space systems. Contributing capabilities are provided by these individual organizations:

Electronics and Photonics Laboratory: Microelectronics, VLSI reliability, failure analysis, solid-state device physics, compound semiconductors, radiation effects, infrared and CCD detector devices, data storage and display technologies; lasers and electro-optics, solid state laser design, micro-optics, optical communications, and fiber optic sensors; atomic frequency standards, applied laser spectroscopy, laser chemistry, atmospheric propagation and beam control, LIDAR/LADAR remote sensing; solar cell and array testing and evaluation, battery electrochemistry, battery testing and evaluation.

Space Materials Laboratory: Evaluation and characterizations of new materials and processing techniques: metals, alloys, ceramics, polymers, thin films, and composites; development of advanced deposition processes; nondestructive evaluation, component failure analysis and reliability; structural mechanics, fracture mechanics, and stress corrosion; analysis and evaluation of materials at cryogenic and elevated temperatures; launch vehicle fluid mechanics, heat transfer and flight dynamics; aerothermodynamics; chemical and electric propulsion; environmental chemistry; combustion processes; space environment effects on materials, hardening and vulnerability assessment; contamination, thermal and structural control; lubrication and surface phenomena.

Space Science Application Laboratory: Magnetospheric, auroral and cosmic ray physics, wave-particle interactions, magnetospheric plasma waves; atmospheric and ionospheric physics, density and composition of the upper atmosphere, remote sensing using atmospheric radiation; solar physics, infrared astronomy, infrared signature analysis; infrared surveillance, imaging, remote sensing, and hyperspectral imaging; effects of solar activity, magnetic storms and nuclear explosions on the Earth's atmosphere, ionosphere and magnetosphere; effects of electromagnetic and particulate radiations on space systems; space instrumentation, design fabrication and test; environmental chemistry, trace detection; atmospheric chemical reactions, atmospheric optics, light scattering, state-specific chemical reactions and radiative signatures of missile plumes.

Center for Microtechnology: Microelectromechanical systems (MEMS) for space applications; assessment of microtechnology space applications; laser micromachining; laser-surface physical and chemical interactions; micropropulsion; micro- and nanosatellite mission analysis; intelligent microinstruments for monitoring space and launch system environments.

Office of Spectral Applications: Multispectral and hyperspectral sensor development; data analysis and algorithm development; applications of multispectral and hyperspectral imagery to defense, civil space, commercial, and environmental missions.



**THE AEROSPACE
CORPORATION**

2350 E. El Segundo Boulevard
El Segundo, California 90245-4691
U.S.A.