



AUTOMOTIVE RESEARCH CENTER

Dr. David Gorsich

Director, Automotive Research Center (ARC)

Director, TARDEC Robotics Lab (TRL)

A Partnership of Eight Research Universities

UNIVERSITY OF MICHIGAN (lead)

WAYNE STATE UNIVERSITY

UNIVERSITY OF WISCONSIN

UNIVERSITY OF IOWA

OAKLAND UNIVERSITY

CLEMSON UNIVERSITY

UNIVERSITY OF ALASKA FAIRBANKS

UNIVERSITY OF TENNESSEE



gorsichd@tacom.army.mil

Report Documentation Page

Report Date 29May2001	Report Type N/A	Dates Covered (from... to) -
Title and Subtitle Automotive Research Center	Contract Number	
	Grant Number	
	Program Element Number	
Author(s) Gorsich, David	Project Number	
	Task Number	
	Work Unit Number	
Performing Organization Name(s) and Address(es) Automotive Research Center (ARC)	Performing Organization Report Number	
Sponsoring/Monitoring Agency Name(s) and Address(es) NDIA (National Defense Industrial Association) 211 Wilson BLvd., Ste. 400 Arlington, VA 22201-3061	Sponsor/Monitor's Acronym(s)	
	Sponsor/Monitor's Report Number(s)	
Distribution/Availability Statement Approved for public release, distribution unlimited		
Supplementary Notes Proceedings from 2001 Vehicle Technologies Symposium - Intelligent Systems for the Objective Force 29-31 May 2001 Sponsored by NDIA, The original document contains color images.		
Abstract		
Subject Terms		
Report Classification unclassified	Classification of this page unclassified	
Classification of Abstract unclassified	Limitation of Abstract UU	
Number of Pages 17		



ARC Mission

<http://arc.engin.umich.edu/>

Conduct basic research that advances the state-of-the-art in high fidelity modeling, simulation and testing of military and civilian ground vehicles

Impact:

- **Achieve vehicle design objectives of versatility, high mobility, durability, reliability, low signature, low cost, and fuel efficiency**
- **Provide linkage between automotive suppliers, manufacturers and the military in the critical product development phase**
- **Educate the technical personnel needed to design and support future military/commercial ground vehicles**



The ARC Organization

- A unique synergistic partnership between academia, industry and government based on Research Quads and Case Studies.
- Senior Advisory Board comprising high level industry executives (including Ford, GM and DCX, GDLS, NaviStar, Mechanical Dynamics Inc. and LMS)

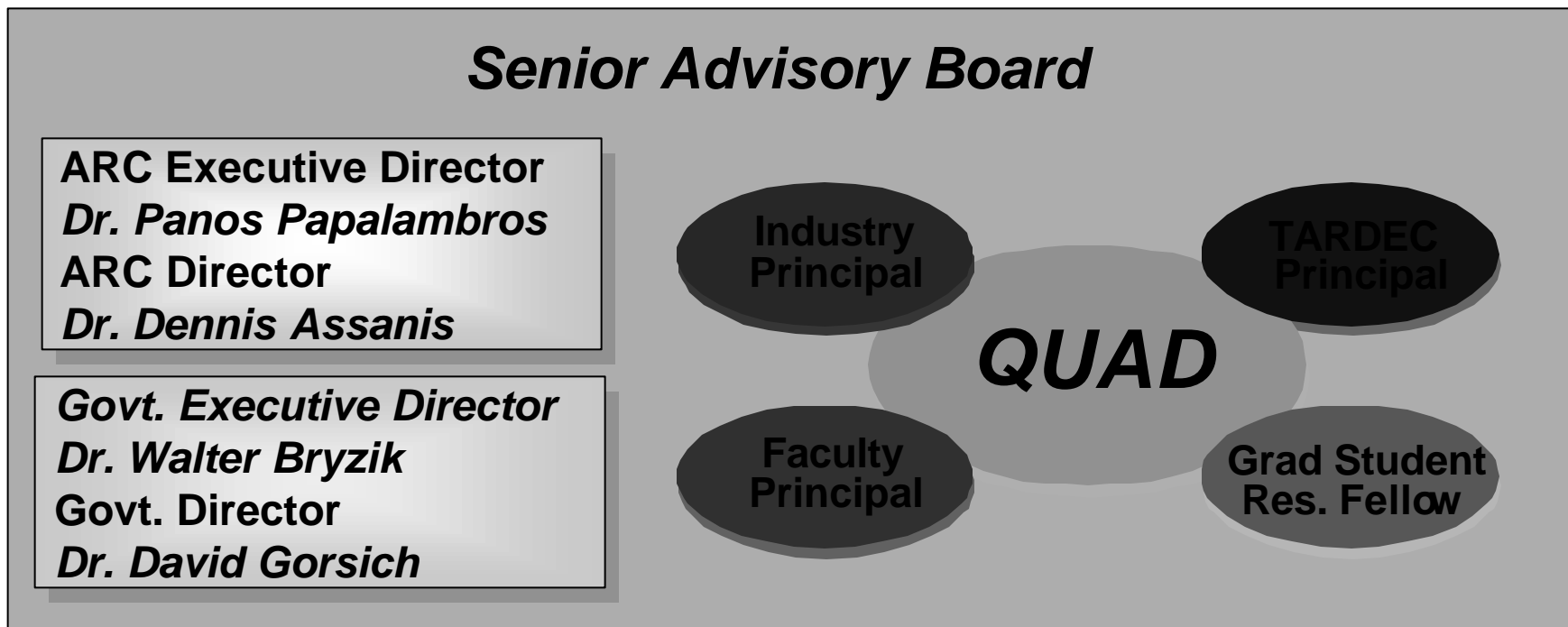



ARC Research Contributors

NATIONAL AUTOMOTIVE CENTER (TACOM-TARDEC)

- Program Coordination
- Military Needs Definition
- Technology Transition
- Dual Use

MICHIGAN (lead university)

- Vehicle Dynamics & Control
- Powertrain Modeling & Testing
- Systems Design Optimization
- Structural NVH & Composites
- Manufacturing links



IOWA

- Virtual Reality
- Human interfaces
- Structural Reliability

WAYNE STATE

- Engine Modeling and Testing
- Friction Studies

TENNESSEE

- Imaging
- ITS
- Hybrid Drivetrains

OAKLAND

- System design
- Control Algorithms
- Manufacturing links

CLEMSON

- Vehicle Dynamics
- Collaborative Design
- Multicriteria Design

ALASKA

- Distributed Comp.
- Fuels/Lubs, low temp studies

WISCONSIN

- Modular Engines
- Transient Powertrain Models
- Design Optimization



Research Partnerships



- **Adiabatics**
- **AlliedSignal, Inc**
- **Allison Engine Company**
- **AM General Corporation**
- **AVL**
- **LMS CADSI**
- **Caterpillar, Inc**
- **Chace & Associates Engineering**
- **DaimlerChrysler Corporation**
- **Deere & Company**
- **Detroit Diesel Corporation**
- **Eaton Corporation**
- **Failure Analysis Associates**
- **FMC United Defense LP**
- **Ford Motor Company**
- **General Dynamics Corporation**
- **General Motors Corporation**
- **Goodyear Tire & Rubber Company**
- **Integrated Systems, Inc**
- **ITT Automotive, Inc**
- **LMS International**
- **Masco Tech**
- **Mathworks, Inc**
- **Mechanical Dynamics, Inc**
- **Mechanical Simulation Corporation**
- **Meritor Automotive**
- **Mitre Corporation**
- **Navistar International Transportation Corporation**
- **OptiMetrics, Inc**
- **P & H Mining Equipment, Inc**
- **Ricardo, Inc**
- **Scientific Systems, Inc**
- **Southwest Research Institute**
- **TASC, Inc**
- **Teledyne Continental Motors**
- **TRW, Inc**
- **Turing Associates, Inc**
- **USCAR**
- **Army CRREL**
- **Army HPCC**
- **Department of Energy**
- **NASA**
- **Department of Transportation**
- **National Renewable Energy Lab**



From Quality and Relevant Core

Spinning off Applied Research Programs

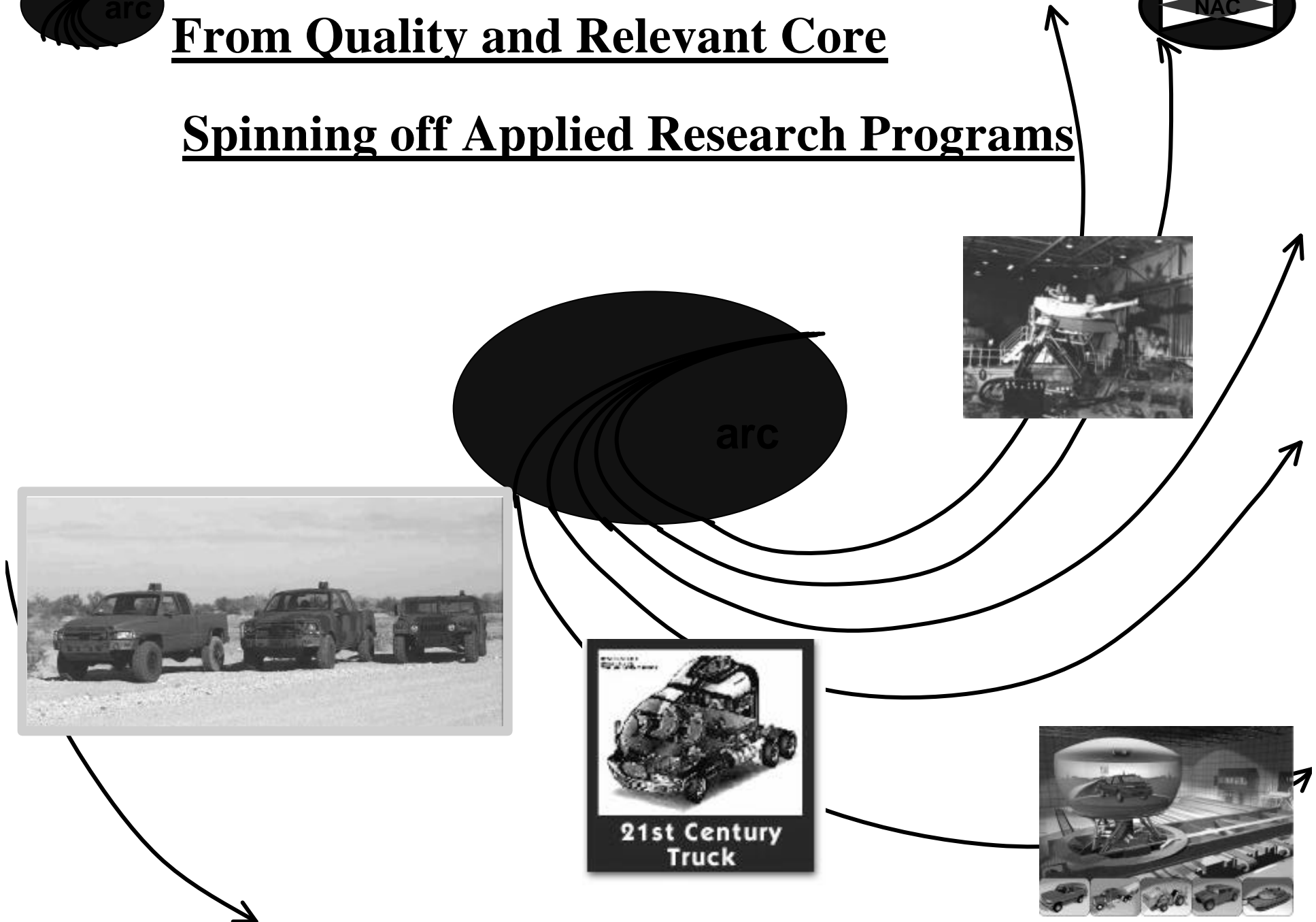
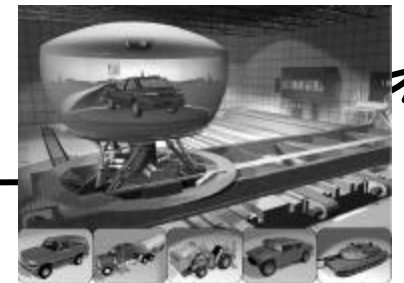



Five Research Thrust Areas

Thrust Areas

“Quad Unit”

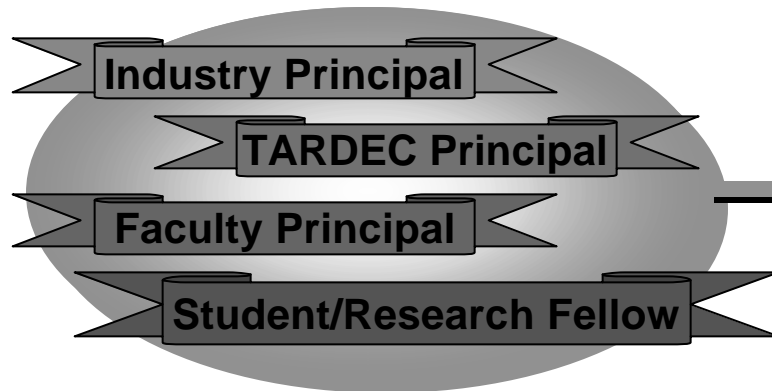

Intelligent Vehicle Dynamics and Control
Dr. Jeffrey Stein, U of M

Human Centered Modeling and Simulation
Dr. Don Chaffin, U of M

High Performance Structures & Materials
Dr. Christophe Pierre, U of M

Advanced and Hybrid Powertrains
Dr. Naeim Henein, Wayne State University

Integrated System Design and Simulation
Dr. Greg Hulbert, U of M



AUTOMOTIVE RESEARCH CENTER



A Partnership of Eight Research Universities

1st Thrust Area: Intelligent Vehicles and Robotics

- Enhance mission efficiencies
- Enhance fleet logistics
- Enhance driver/soldier efficiencies
- Reduce fuel consumption
- Increase mission safety margins
- Reduce overall emissions
- Reduce mission crew size

- Dynamic Route Guidance
- Driver Condition Systems
- Vehicle Dynamics/Stability

Design of Control System for Continuously Variable Transmission (CVT) System

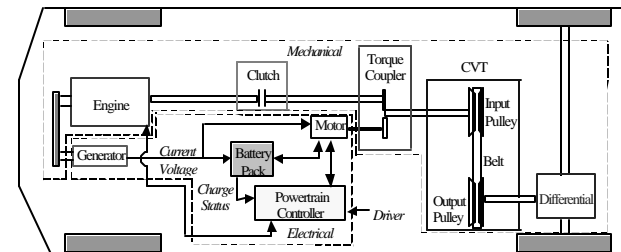

Parallel Hybrid Vehicle Featuring a CVT

- Fleet Management
- Vehicle Diagnostics
- Vehicle Optimal Design



Intelligent Vehicle Dynamics and Control

Major Performers

- University of Michigan
- Oakland University
- Clemson University
- University of Tennessee
- Industry partners

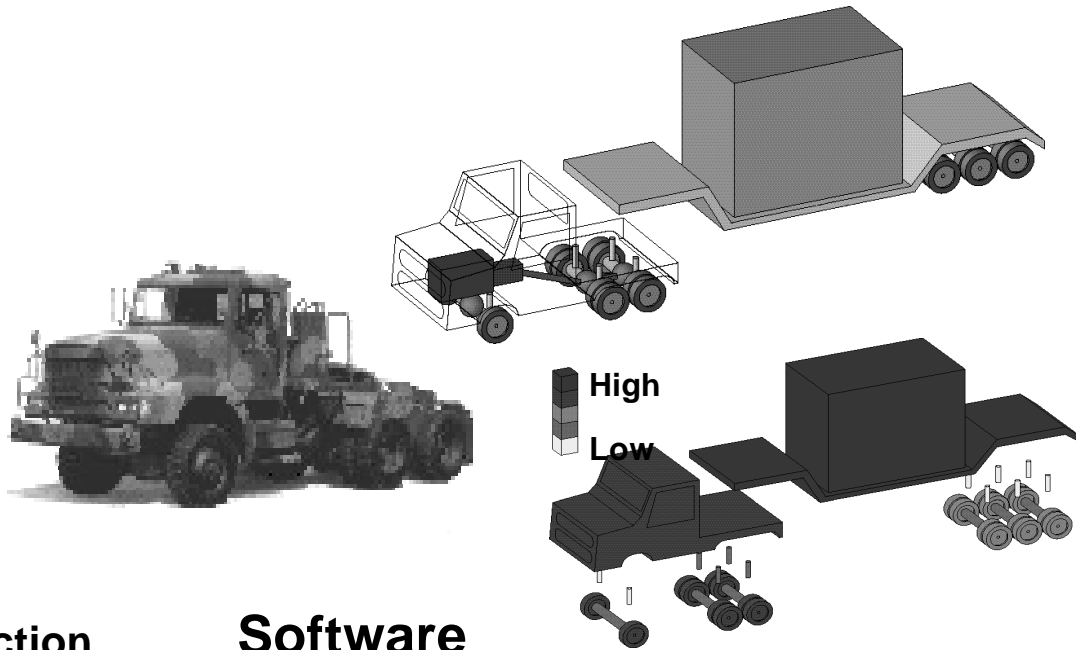

Accomplishments

- Energy Based Model Reduction Strategy
- Worst-Case Evaluation of Vehicle and Vehicle Control Systems
- Efficient Formulation Methods for Vehicle/Tire Models
- Design Optimization for Rollover Performance
- Heavy-Duty Truck Simulation

Software

- ArcSim: A vehicle dynamics simulation environment with a series of variable complexity models, such as for the M916 military truck
- VESIM: Complete vehicle model that includes vehicle dynamics, engine, and driveline



Simplified Model

Simplified roll/yaw models need to be constructed

Roll model

	Rigid Vehicle	+ <i>Compliant</i> Tires	+ <i>Compliant</i> Suspensions	+ <i>Compliant</i> Fifth Wheel	ArcSim
Number of States	0	2	4	8	91
Roll Plane Model					

Model Error (steady-state cornering)

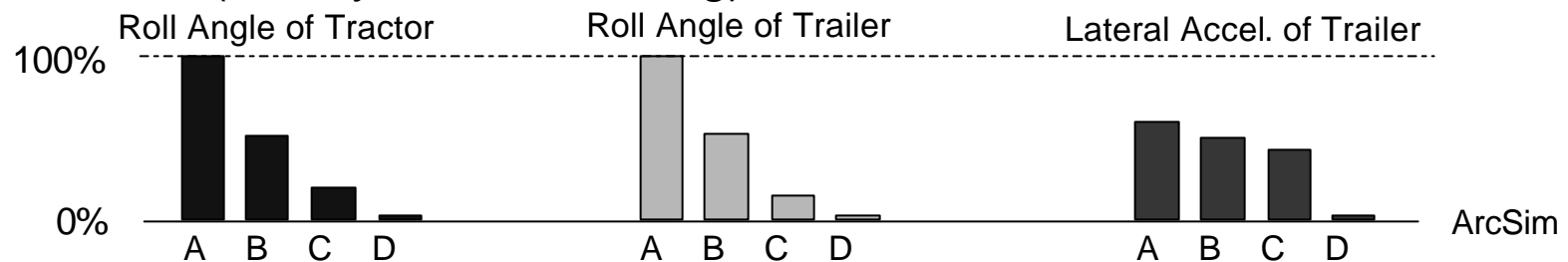

Computation time

Model D = 200 x ArcSim = 70 x Real Time (200 MHz Pentium)



Rollover Warning

- **Objective:**
 - **Develop a dynamic rollover prediction algorithm which indicates vehicle rollover threats so that preventative actions can be taken.**
- **Critical issues:**
 - **Accurate and fast (60 x real-time) model.**
 - **Metric to indicate rollover threat accurately under a wide variety of maneuvers.**

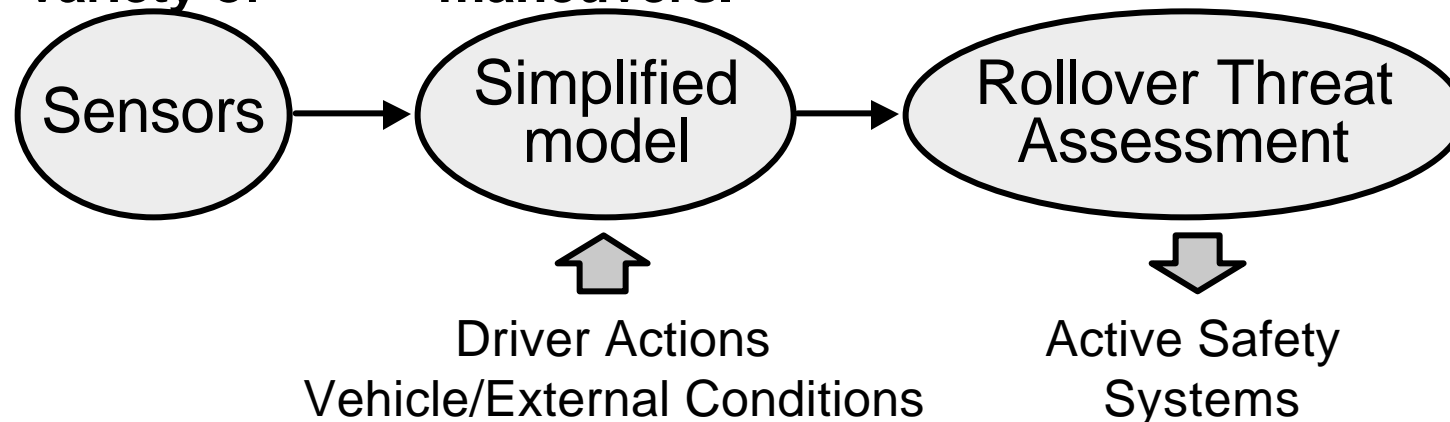



Virtual and Synthetic Environments

Major Performers

- University of Iowa
- University of Tennessee
- NSF I/UCRC for virtual proving ground simulation
- US DoT
- Industry partners

Accomplishments

- Synthetic and Virtual Environments
 - Off-Road Synthetic Environments
 - Numerical Methods for High-Fidelity, Real-Time Simulation
 - Parallel Computation for Real-Time Simulation
 - Integrated ARC Tools for Virtual Proving Ground Simulation
- 3D Imaging and Data Fusion for Automotive Simulation and Design

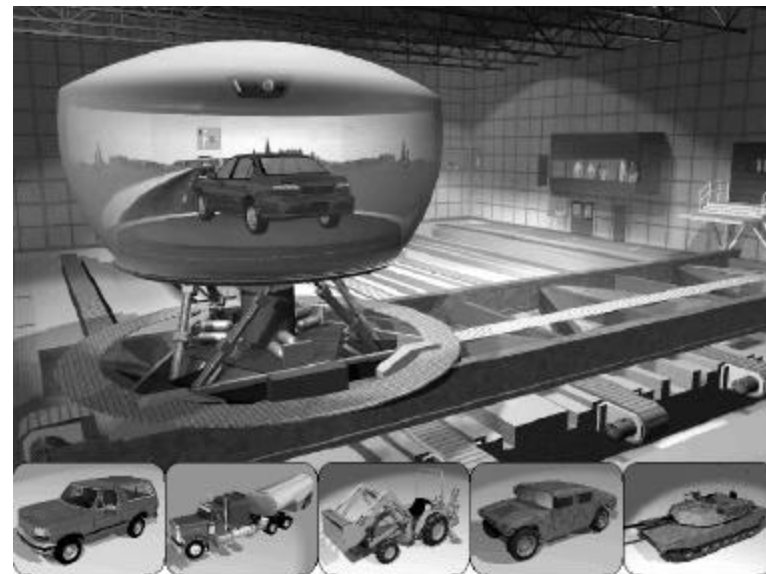

Software

- Implicit integrators and linear solvers transitioned to DADS
- Real-time dual coordinate software implemented on TARDEC simulators
- Off-road virtual proving grounds for TARDEC simulators and the NADS



UTENN 3D IMAGING AND DATA FUSION



GOAL

- Design, Build, and Test a mobile sensor platform to be navigated through on-road and/or off-road environments to capture data and construct realistic, virtual representations of those environments
- Automatically generate realistic scene databases from captured data, suitable for real-time simulation in the NADS/TARDEC framework

Desirable characteristics of completed system

- ❖ All data captured while vehicle moves at a reasonable speed.
- ❖ Capture complete data over a 20-mile stretch
- ❖ Automatically produce virtual environment with minimal human intervention
- ❖ Retain manual modification capabilities in final virtual scene.



Potential sensor suite

- ❖ GPS for rough geometry of the road/path.
- ❖ Laser range scanner for accurate, 3D data acquisition.
- ❖ Multiple video cameras for:
 - Texture.
 - 3D data from multiview/stereo analysis.
 - Road surface acquisition (texture, lines).
 - Other scene characteristics.
- ❖ Ground penetrating radar for improved road surface characterization.



Advanced and Hybrid Powertrains

Major Performers

- University of Michigan
- Wayne State University
- University of Wisconsin-Madison
- Industry partners

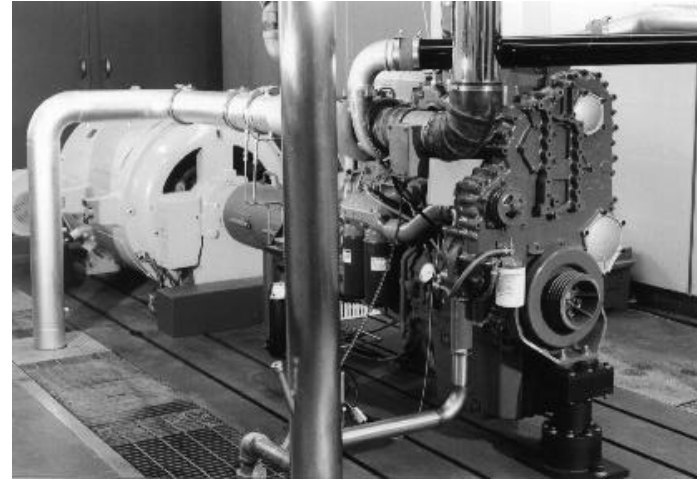

Accomplishments

- Physical models of transient engine processes
- State-of-the-art experimental validation of models
- New electronic controls to reduce signature in the field
- Powertrain simulations for actual wheeled and tracked vehicles

Transitions

- High-fidelity engine and driveline transient simulation modules
- New diagnostic techniques for fuel injection, combustion, heat transfer, and white smoke
- New electronic controls to improve cold-start and reduce white smoke



Vehicle System Integration

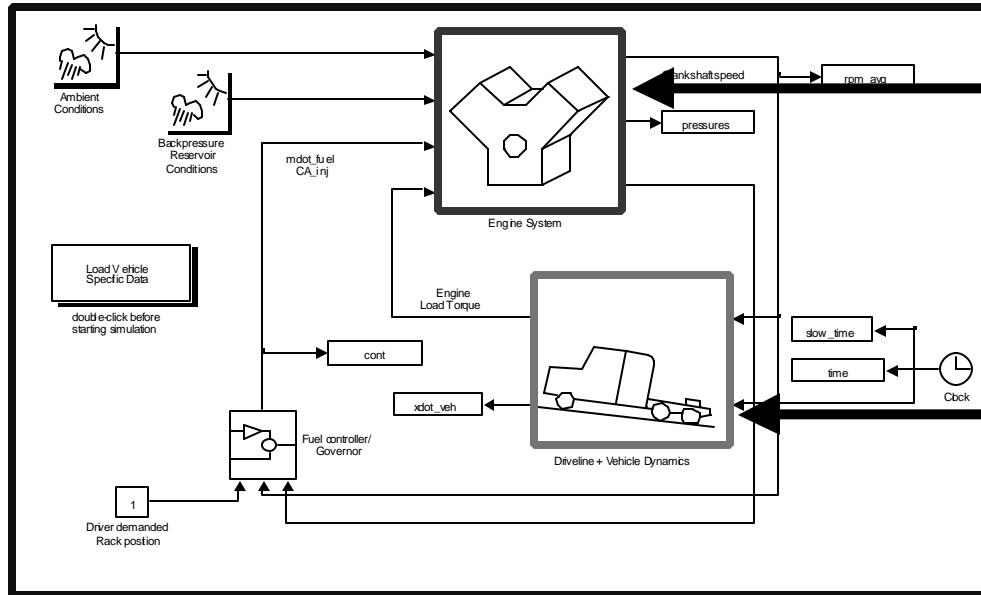

ENGINE SYSTEM

DRIVE - LINE

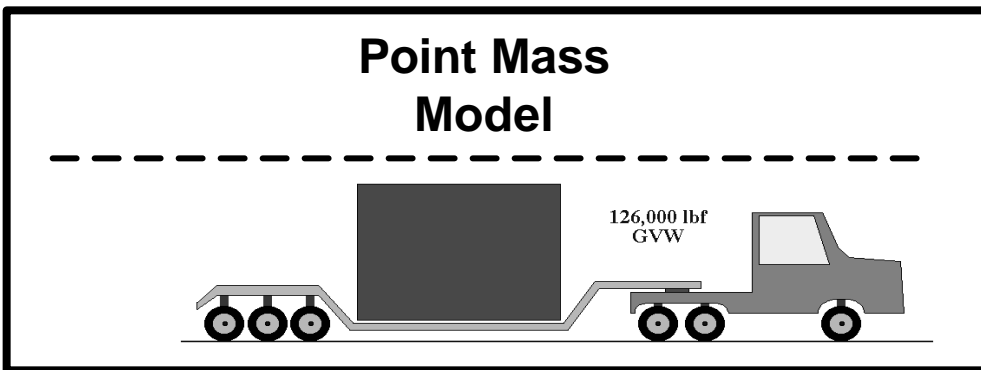

VEHICLE DYNAMICS

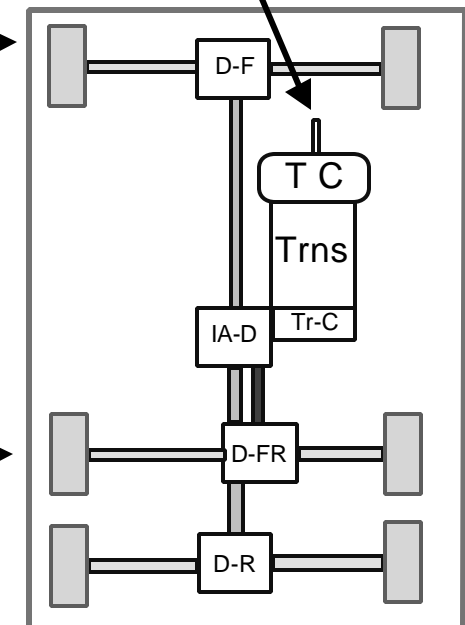
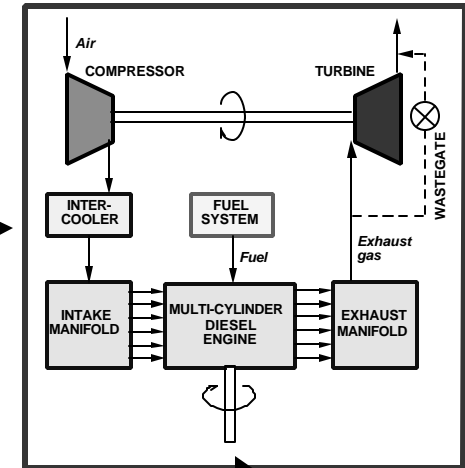



Summary

- **ARC Research is concentrating on developing expertise in individual technology areas while providing modeling and simulation tools in five thrust areas.**
- **Case Studies focus on specific engineering problems: FCS, 21Truck, etc.**
- **New initiatives being ramped up in distributed simulations across high-speed networks - iARC - Human-based modeling and Simulation - Whole life product development.**

<http://arc.engin.umich.edu/>