

KDI Precision Products, Inc.

An ISO 9001 Registered Company

45th Annual Fuze Conference

"The Evolving Nature of Value Added Fuzing"



Presented by: Mr Ted Lewis

www.kdi-ppi.com



Report Documentation Page

Report Date 16Apr2001	Report Type N/A	Dates Covered (from... to) -
Title and Subtitle The Evolving Nature of Value Added Fuzing	Contract Number	
	Grant Number	
	Program Element Number	
Author(s) Lewis, Ted	Project Number	
	Task Number	
	Work Unit Number	
Performing Organization Name(s) and Address(es) KDI Precision Products, Inc.	Performing Organization Report Number	
Sponsoring/Monitoring Agency Name(s) and Address(es) NDIA (National Defense Industrial Association) 211 Wilson Blvd., Ste. 400 Arlington, VA 22201-3061	Sponsor/Monitor's Acronym(s)	
	Sponsor/Monitor's Report Number(s)	
Distribution/Availability Statement Approved for public release, distribution unlimited		
Supplementary Notes Proceedings from The 45th Annual Fuze Conference, 16-18 April 2001 Sponsored by NDIA, The original document contains color images.		
Abstract		
Subject Terms		
Report Classification unclassified	Classification of this page unclassified	
Classification of Abstract unclassified	Limitation of Abstract UU	
Number of Pages 19		

GUIDED MLRS USA AND FOREIGN PARTNERS

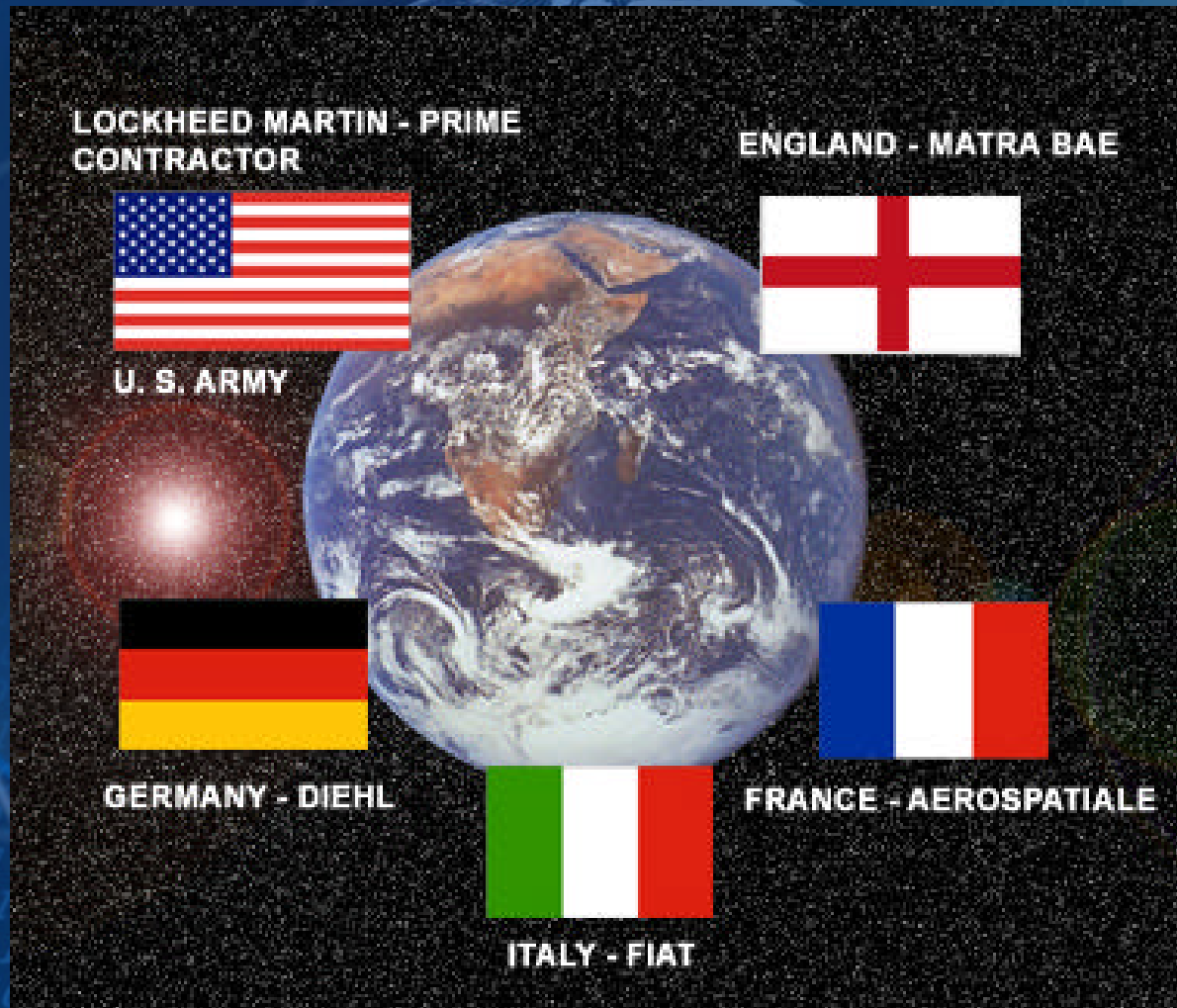

www.kdi-ppi.com



KDI PROGRAM TEAM

- Mike Buckhanan - Program Manager
- Ted Lewis - Electrical Project Engineer
- Cory Hatch - Electrical Engineer
- Tony Zucker - Mechanical Project Engineer
- Mike Sowder - Test Equipment Electrical Engineer
- Steve Gemperline - Quality Engineer, CQE
- Bob Garrett - Reliability Engineer
- Tom Moore - Manufacturing Engineer
- Bob Butts - Configuration Management



GMLRS OPERATION

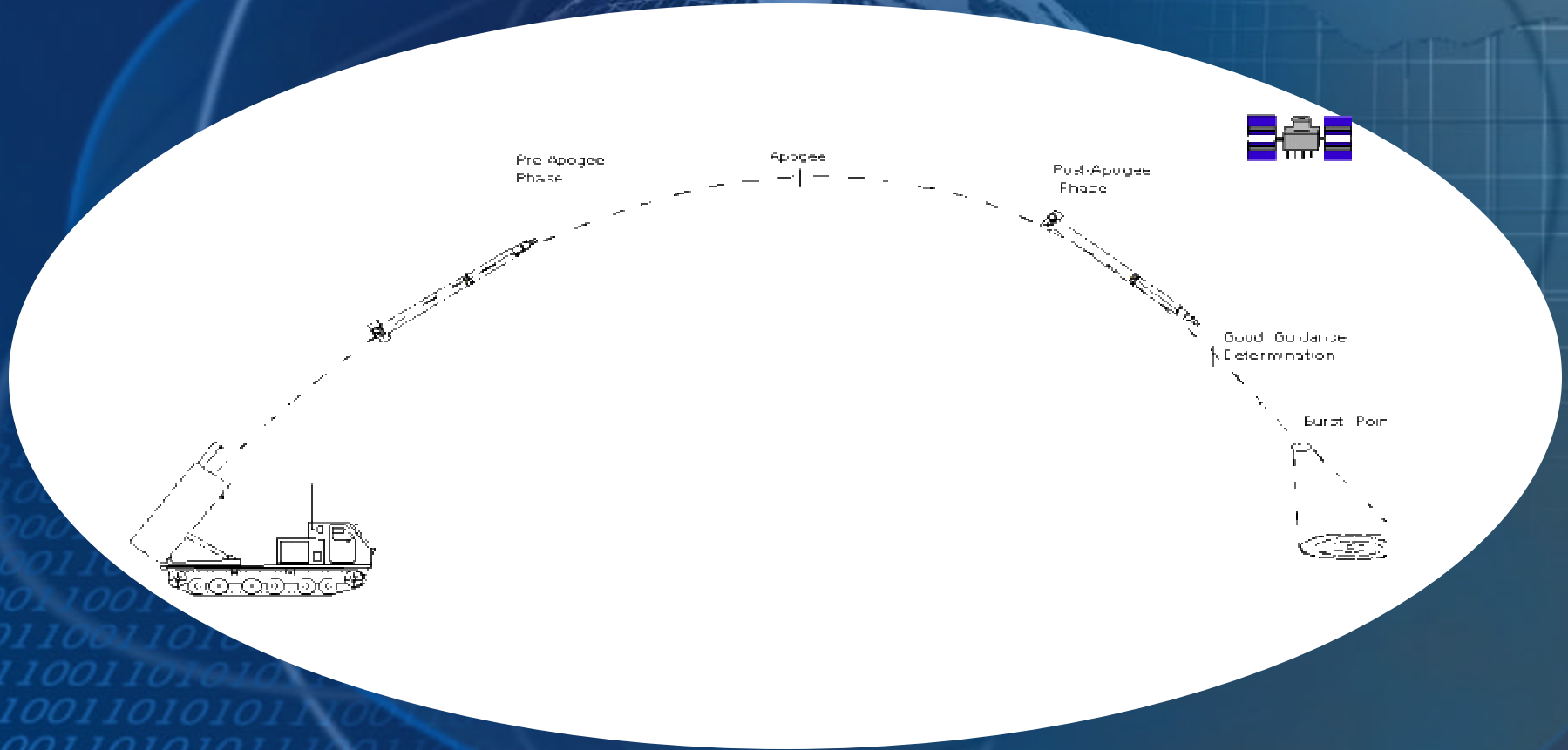

GMLRS ROCKET

- The GMLRS Rocket Is Nominally a Ballistic Round
- The Maximum Off-axis Shot Is 4° Degrees
- The Canards Are Used Only for Trimming the Trajectory During the Flight

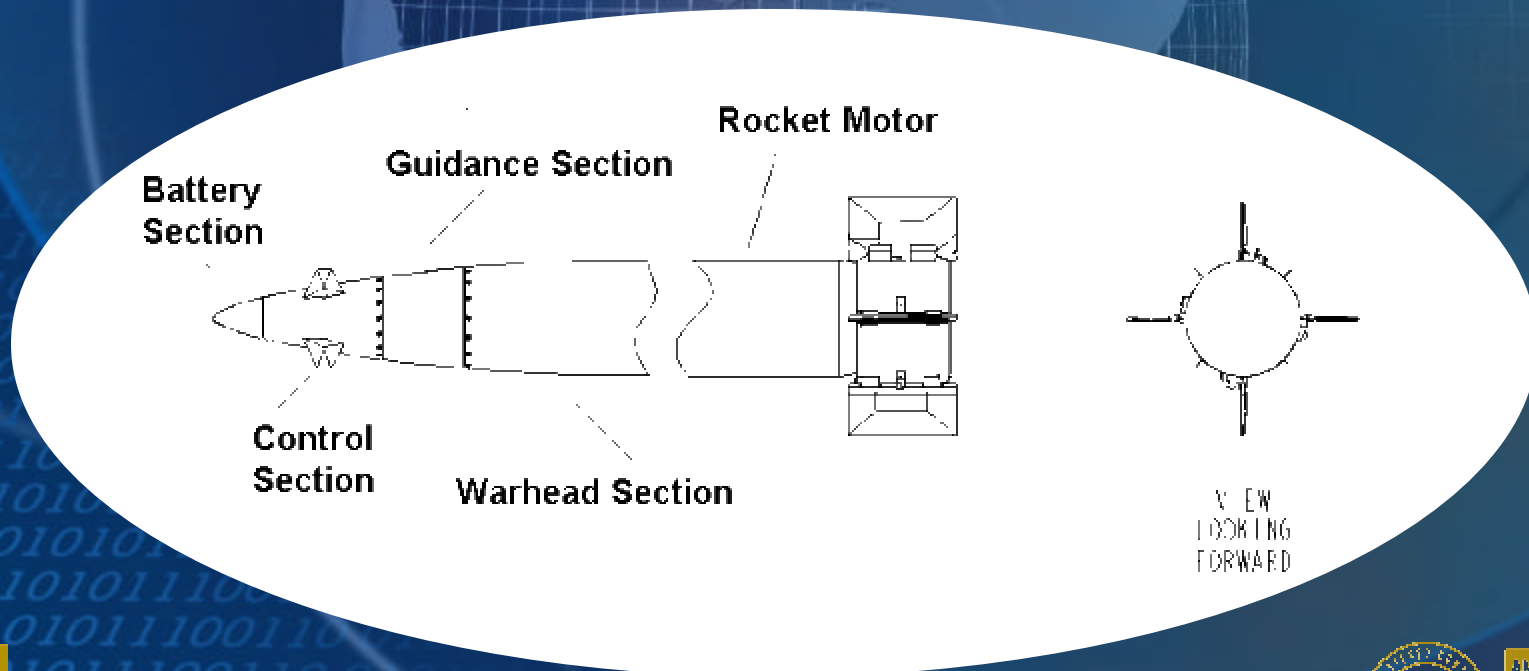

GUIDANCE AND CONTROL SECTION

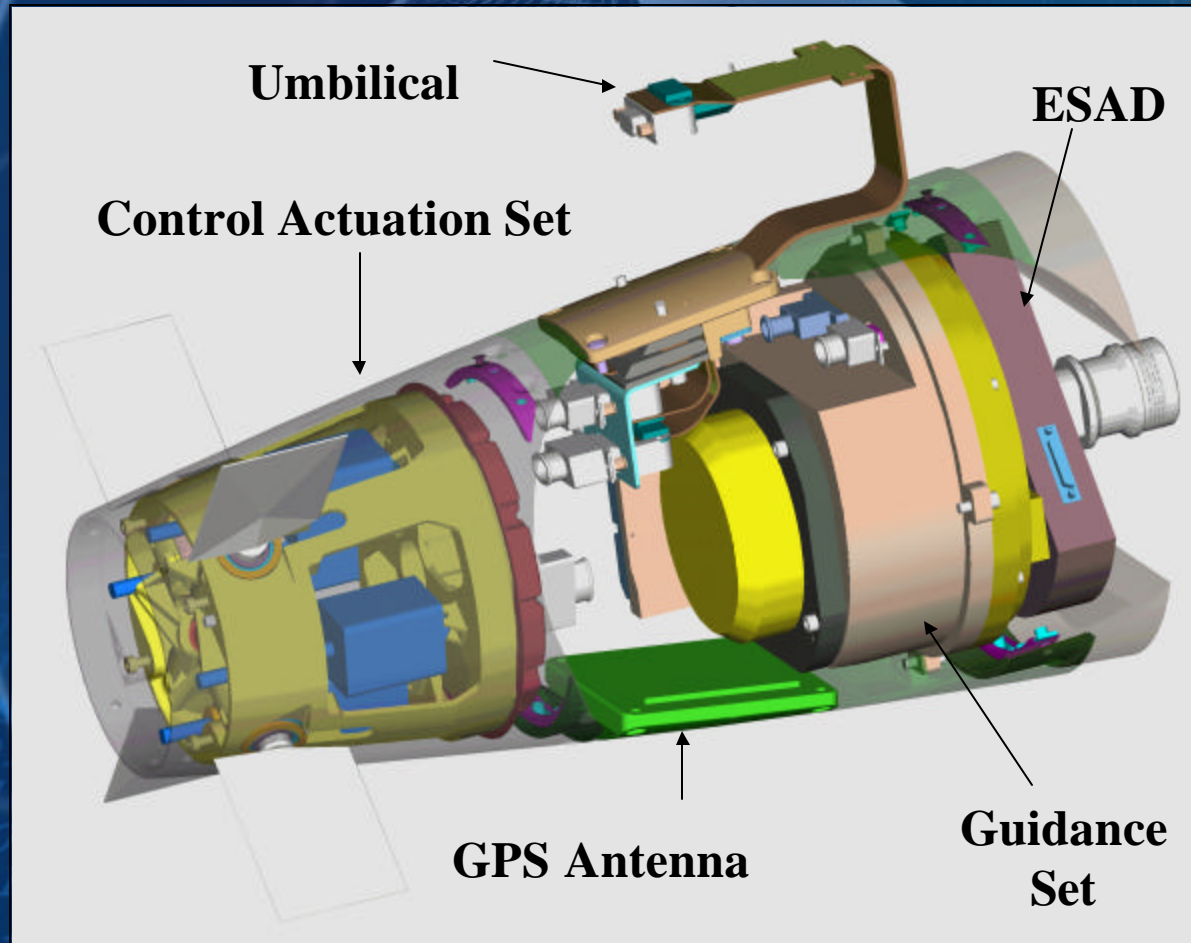

HOUSING

- Material: 304L Stainless Steel
- Function
 - Interfaces to LEEFI Adapter Assembly
 - Interfaces With Rocket
 - Alignment Feature Incorporated
 - Hermetic Environment
 - Supports Printed Wiring Board (PWB)



SEALING

- The ESAD Will Be Hermetically Sealed and Tested to Meet a Leak Rate of 1×10^{-6} cc/sec He/Mass Spectrometer at 1 Atmosphere Pressure Differential
- Laser Welding Will Be Used to Seal the Housing, Similar to the Other Qualified Programs at KDI
- The GMLRS ESAD Will Be Back-filled With Nitrogen With A Trace Of Helium Through A Fill Plug



EXPLODED VIEW

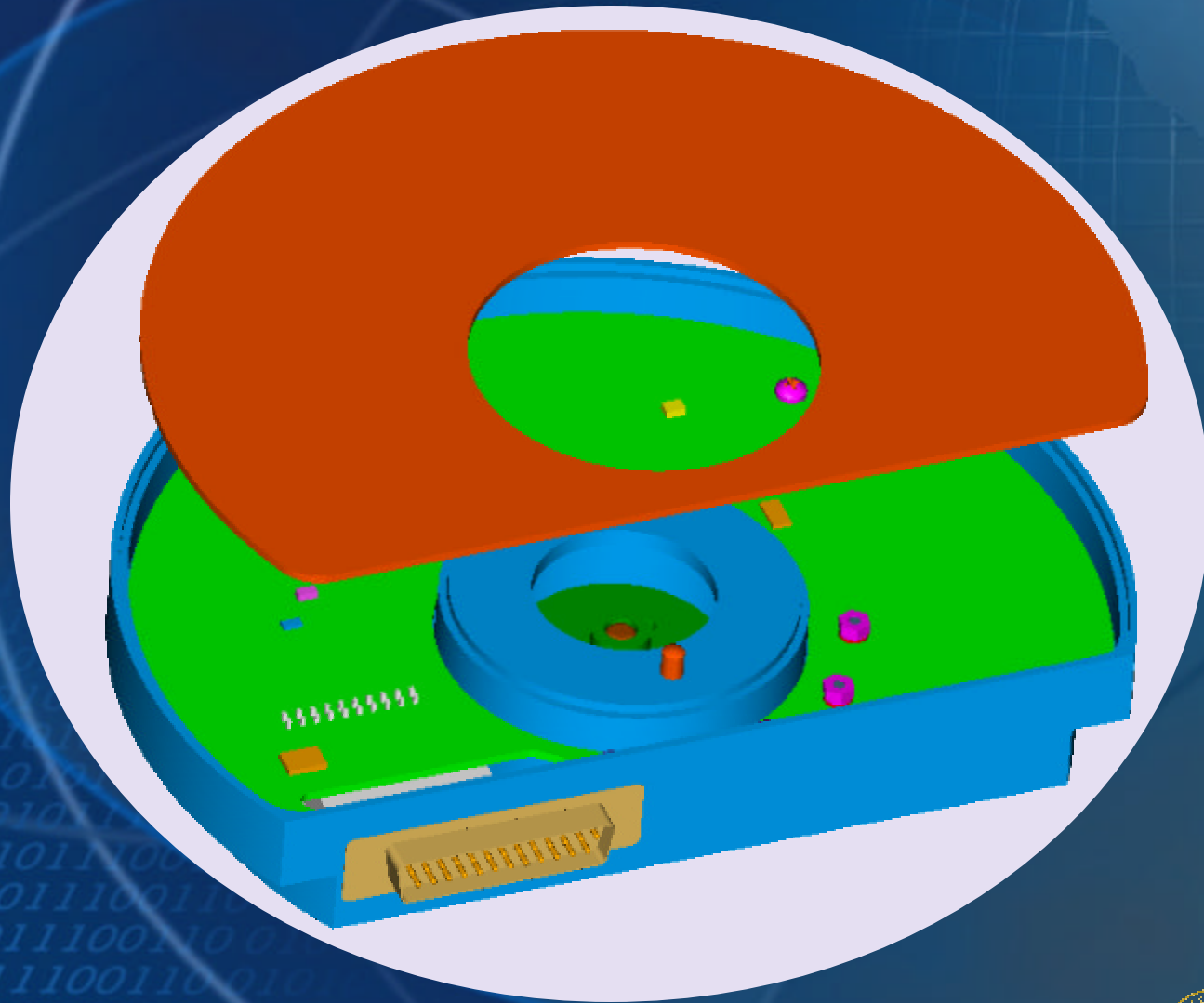

www.kdi-ppi.com



LEEFI ADAPTER ASSEMBLY

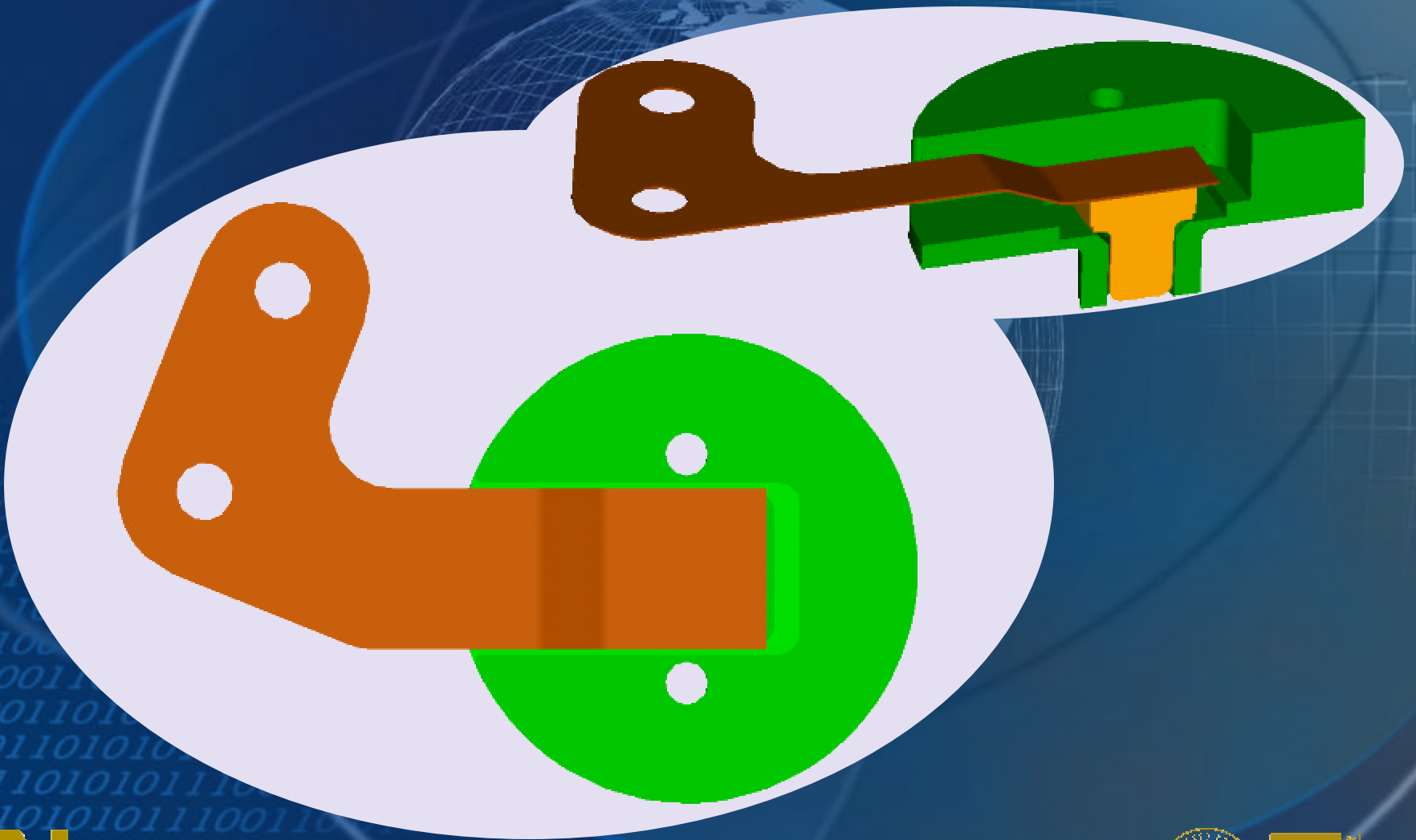

www.kdi-ppi.com



GMLRS ESAD WITH LEEFI ADAPTER ASSEMBLY

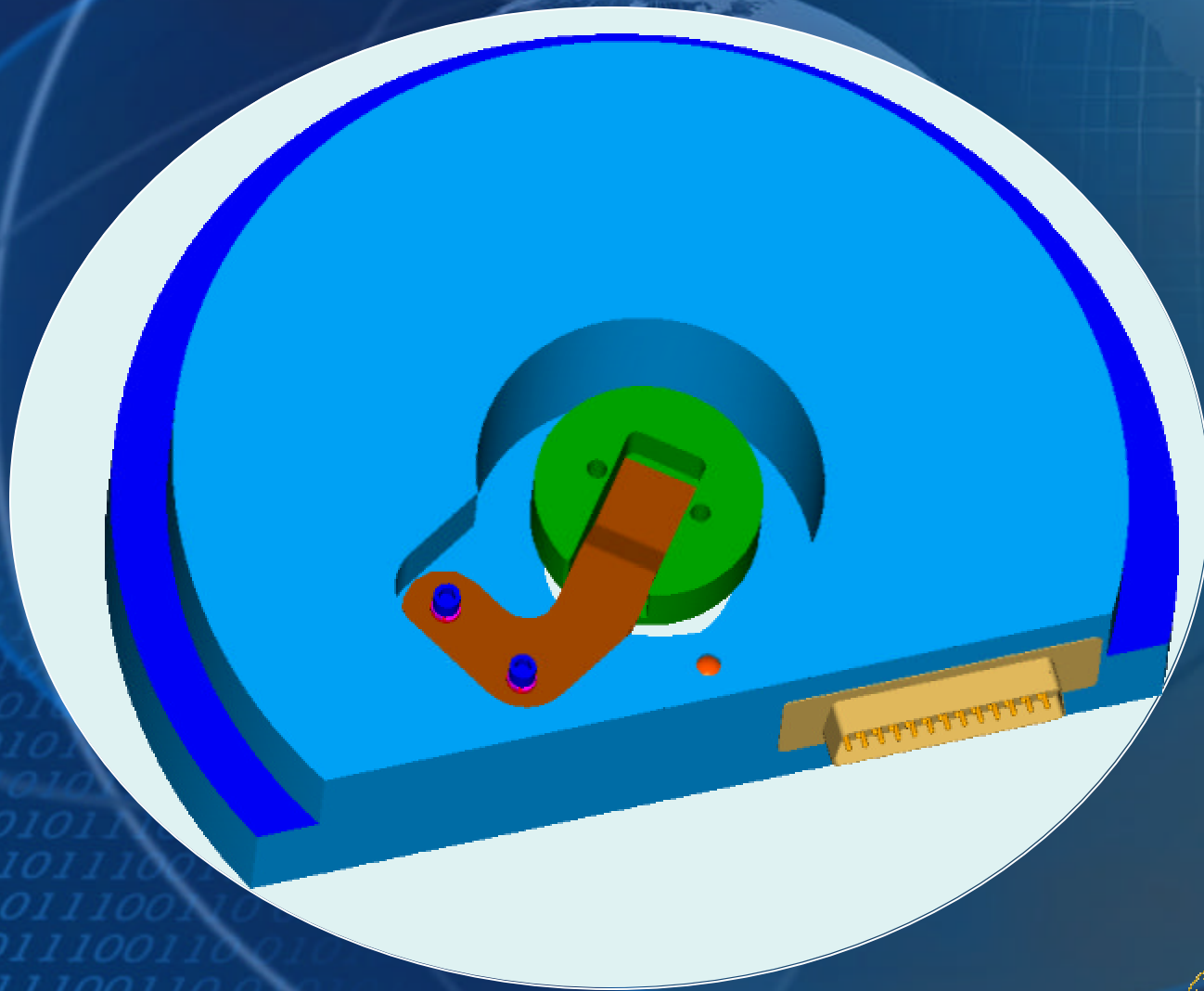

www.kdi-ppi.com



DETAILED BLOCK DIAGRAM

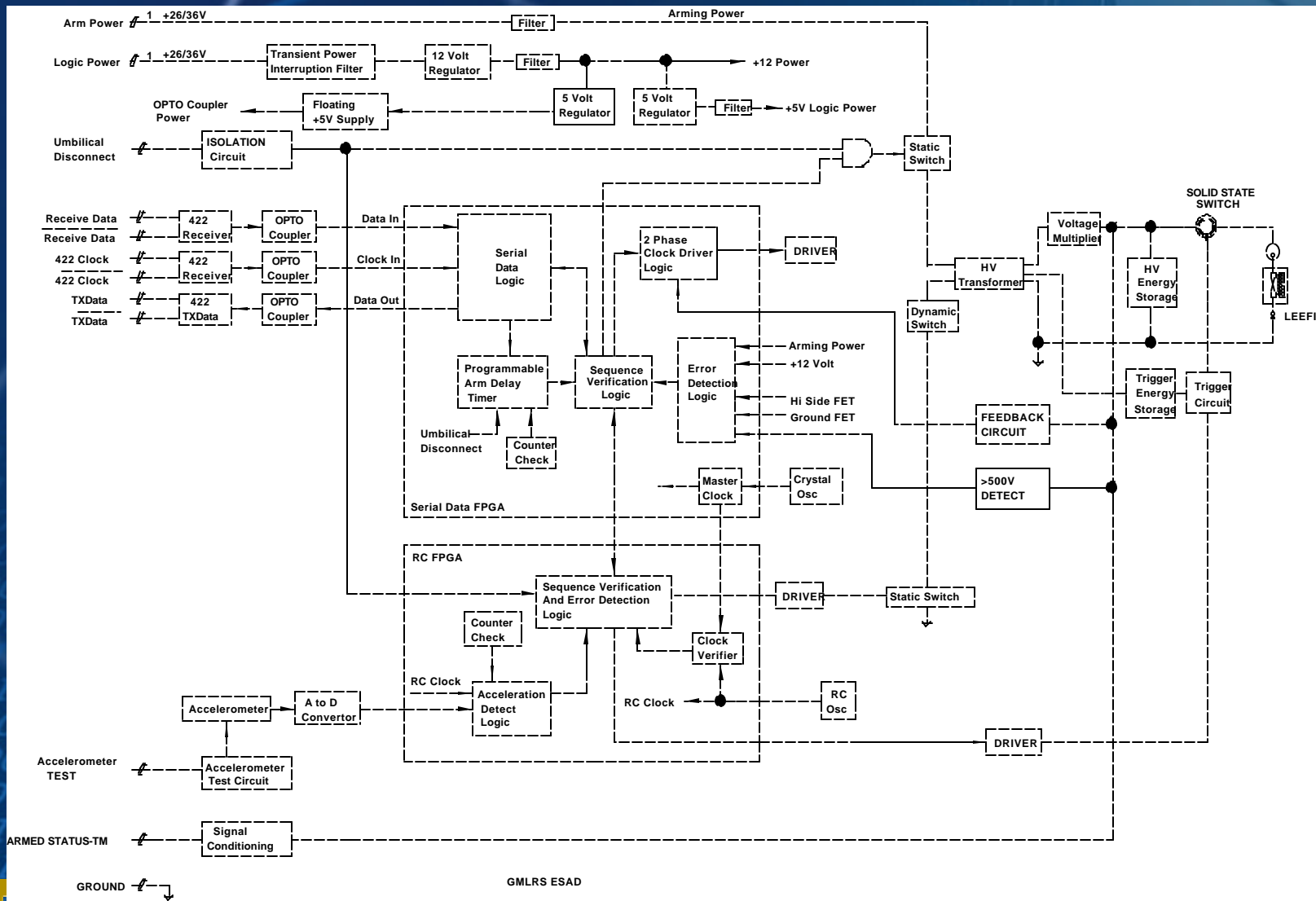

TIMING DIAGRAM

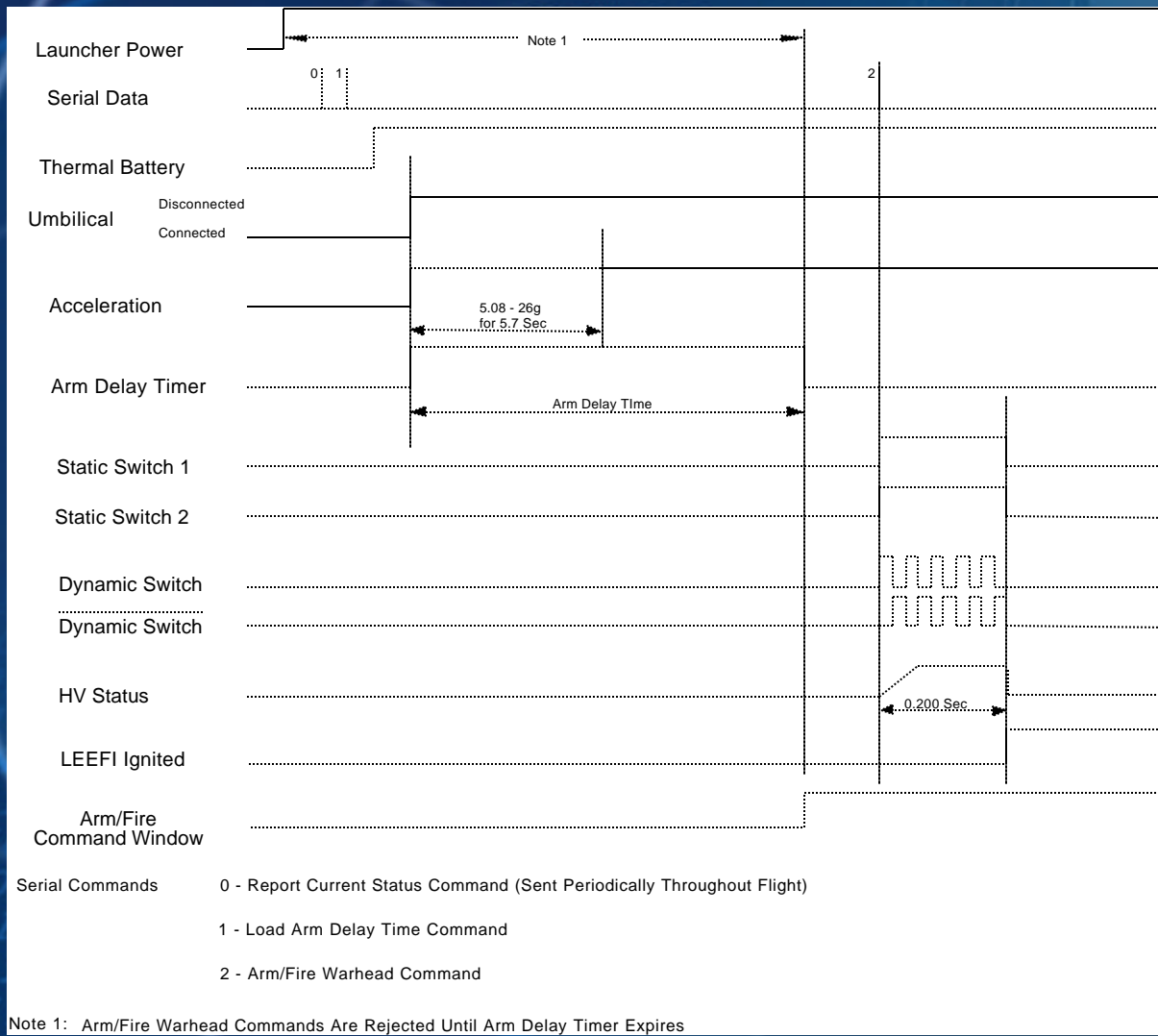

SERIAL INTERFACE

- 442 Drivers/Receivers
- SDLC Message Formats

Guidance to ESAD
Message

48 BITS

- 8 BIT Start Word
- 8 BIT Command Word
- 8 BIT Delay Time
- 16 BIT CRC
- 8 BIT Stop Word

ESAD to Guidance Message
64 BITS

- 8 BIT Start Word
- 20 BIT Command Word
- 4 BIT Delay Time
- 8 BIT Timer Status
- 16 BIT CRC
- 8 BIT Stop Word



ACCELERATION PROCESSING

- Motorola MMA1201P Analog Accelerometer
 - $\pm 40g$ Capacitive, Micromachined Accelerometer
 - Output Sensitivity = 50 ± 2.5 mV/g
- Accelerometer Readings Are Taken Every $340\mu S$
- Accelerometer Output Level Checked During BIT
- Accelerometer Output Level “Nulled” When Battery Power is Applied
- Specification Requirements:
 - 1st Motion = $5.08g$ for 6 msec Within 0.5s From Umbilical Disconnect
 - Safe Separation = $5.08g$ for 5.7 ± 0.1 Seconds



LEEFI ASSEMBLY

- Designed in Unison by China Lake, Reynolds Systems and Silicon Designs
- The LEEFI Has Been Qualified by China Lake IAW MIL-STD-331, Test G1
- Specific Tests Designed to Demonstrate the Initiator Meets a Reliability of 0.99 at a 95% Confidence Level Were Performed



MCT SEMICONDUCTOR DISCHARGE SWITCH

- N-Type MOS-Controlled Thyristor
- 1400 Volt
- 4ka Surge Current
- Silicon Power Corporation
- Tested in KDI IRAD Program
 - > 20,000 Discharges



PROGRAM STATUS / SCHEDULE

- Initial AFSRB Presentation - Completed 19 Dec 2000
- PDR - Completed 1-2 Feb 2001
- Engineering Tests - 15 Nov 2000 To 31 Mar 2001
- CDR - 27-28 Mar 2001
- Qualification - 30 May 2001 To 17 Jul 2001
- Flight Hardware Delivery 1 June -28 Sept 2001



QUALIFICATION TESTING

- Twenty ESADS Will Be Subjected to Qualification Testing
- The Qualification Test Environments Will Consist Of:
 - Thermal Shock
 - Tactical Vibration
 - Launch Shock
 - High Temperature Operation
 - Low Temperature Operation
 - Acoustic Noise and Flight Simulation
- Electromagnetic Environment

