

AD\_\_\_\_\_

Award Number: DAMD17-00-1-0348

TITLE: Function of Etk in Growth Factor Receptor Signaling to Integrins in Breast Cancer

PRINCIPAL INVESTIGATOR: Yoji Shimizu, Ph.D.

CONTRACTING ORGANIZATION: University of Minnesota  
Minneapolis, Minnesota 55455

REPORT DATE: May 2001

TYPE OF REPORT: Annual

PREPARED FOR: U.S. Army Medical Research and Materiel Command  
Fort Detrick, Maryland 21702-5012

DISTRIBUTION STATEMENT: Approved for Public Release;  
Distribution Unlimited

The views, opinions and/or findings contained in this report are those of the author(s) and should not be construed as an official Department of the Army position, policy or decision unless so designated by other documentation.

20010928 031

**REPORT DOCUMENTATION PAGE**Form Approved  
OMB No. 074-0188

Public reporting burden for this collection of information is estimated to average 1 hour per response, including the time for reviewing instructions, searching existing data sources, gathering and maintaining the data needed, and completing and reviewing this collection of information. Send comments regarding this burden estimate or any other aspect of this collection of information, including suggestions for reducing this burden to Washington Headquarters Services, Directorate for Information Operations and Reports, 1215 Jefferson Davis Highway, Suite 1204, Arlington, VA 22202-4302, and to the Office of Management and Budget, Paperwork Reduction Project (0704-0188), Washington, DC 20503

<b>1. AGENCY USE ONLY (Leave blank)</b>		<b>2. REPORT DATE</b> May 2001	<b>3. REPORT TYPE AND DATES COVERED</b> Annual (1 May 00 - 30 Apr 01)	
<b>4. TITLE:</b> Function of Etk in Growth Factor Receptor Signaling to Integrins in Breast Cancer			<b>5. FUNDING NUMBERS</b> DAMD17-00-1-0348	
<b>6. AUTHOR(S)</b> Yoji Shimizu, Ph.D.				
<b>7. PERFORMING ORGANIZATION NAME(S) AND ADDRESS(ES)</b> University of Minnesota Minneapolis, Minnesota 55455 Email - shimi002@umn.edu			<b>8. PERFORMING ORGANIZATION REPORT NUMBER</b>	
<b>9. SPONSORING / MONITORING AGENCY NAME(S) AND ADDRESS(ES)</b> U.S. Army Medical Research and Materiel Command Fort Detrick, Maryland 21702-5012			<b>10. SPONSORING / MONITORING AGENCY REPORT NUMBER</b>	
<b>11. SUPPLEMENTARY NOTES</b> Report contains color graphics				
<b>12a. DISTRIBUTION / AVAILABILITY STATEMENT</b> Approved for Public Release; Distribution Unlimited			<b>12b. DISTRIBUTION CODE</b>	
<b>13. Abstract (Maximum 200 Words) (abstract should contain no proprietary or confidential information)</b> The central hypothesis in this IDEA Award is that increased integrin-mediated adhesiveness and migration of breast cancer cells in response to stimulation by the growth factors heregulin $\beta$ (HRG $\beta$ ) or epidermal growth factor is mediated by phosphoinositide 3-OH kinase-dependent activation and membrane recruitment of the novel Tec family tyrosine kinase Etk. During the past year, we have made progress in several aspects of the initial Statement of Work, including: 1) characterization of Etk expression in various tumor cell lines and establishment of a correlation between Etk expression and tumor cells with high migratory capacity; 2) demonstration of HRG $\beta$ -dependent increases in tyrosine phosphorylation of endogenous Etk in breast cancer cells; 3) demonstration of an inhibitory effect of kinase-inactive Etk on HRG $\beta$ -induced increases in breast cancer cell adhesion to collagen; 4) demonstration of inhibitory effects of blocking Etk production by antisense on basal migration of breast cancer cells; and 5) production and establishment of molecular reagents and methodologies critical to completion of the Statement of Work. During the past year, we have also uncovered a novel mechanism of regulation of Etk tyrosine kinase activity by integrin receptors.				
<b>14. SUBJECT TERMS</b> Breast Cancer, Adhesion, Migration, Integrin, Epidermal Growth Factor, Heregulin, Etk, Tyrosine Kinase			<b>15. NUMBER OF PAGES</b> 34	
			<b>16. PRICE CODE</b>	
<b>17. SECURITY CLASSIFICATION OF REPORT</b> Unclassified	<b>18. SECURITY CLASSIFICATION OF THIS PAGE</b> Unclassified	<b>19. SECURITY CLASSIFICATION OF ABSTRACT</b> Unclassified	<b>20. LIMITATION OF ABSTRACT</b> Unlimited	

## TABLE OF CONTENTS

	<u>Page</u>
Front Cover	1
SF298/Report Documentation Page	2
Table of Contents	3
Introduction	4
Body	4
Key Research Accomplishments	9
Reportable Outcomes	9
Conclusions	10
References	11
Appendices	13

## INTRODUCTION

Breast cancer cell metastasis is critically dependent on integrin receptors, which mediate adhesion and subsequent cell migration [1-3]. Although quantitative changes in the level of expression of specific integrins have been implicated in breast cancer development, it is now clear that qualitative regulation of the functional activity of breast cancer cells also plays a critical role in regulating breast cancer cell adhesion and migration [4,5]. We have recently shown that stimulation of breast cancer cells with the growth factor heregulin- $\beta$  (HRG $\beta$ ) leads to a rapid increase in integrin-mediated adhesion of these cells to type IV collagen and laminin, and subsequent migration through collagen- and laminin-coated filters [4]. HRG $\beta$  also leads to potent activation of the lipid kinase phosphoinositide 3-OH kinase (PI 3-K), and inhibition of PI 3-K with chemical or genetic inhibitors blocks HRG $\beta$ -induced increases in integrin-dependent adhesion and migration of breast cancer cells. Similar responses were observed following stimulation of breast cancer cells with epidermal growth factor (EGF), although the magnitude of the responses were not as high as those observed with HRG $\beta$ . Similar effects of HRG $\beta$  on PI 3-K activity and migration of breast cancer cells have been reported by other groups [6,7]. In this IDEA Award, we are testing the hypothesis that increased integrin-mediated adhesiveness and migration of breast cancer cells in response to HRG $\beta$  or EGF is mediated by PI 3-K-dependent activation and membrane recruitment of the novel Tec family tyrosine kinase Etk. The specific objectives of the proposal include: 1) determining the role of PI 3-K in HRG $\beta$ - and EGF-induced activation of Etk in breast cancer cells; 2) determining the role of Etk in regulating HRG $\beta$ - and EGF-induced increases in  $\beta$ 1 integrin-dependent adhesion and migration of breast cancer cells; and 3) identifying a function for Etk in regulating HRG $\beta$ - and EGF-induced actin polymerization in breast cancer cells.

## BODY

### EXPERIMENTAL METHODS.

*Cell lines.* The MDA-MB-435s, and T47D cells were maintained in RPMI medium (Gibco) supplemented with 10% Bovine calf serum (FCS, Atlanta Biologicals). SKBR3 cells were grown in McCoy's 5a medium (Celox Laboratories) containing 15% FCS. All cell lines were obtained from ATCC and all cell culture media were supplemented with 2 mM L-glutamine, and 50 U/ml penicillin/streptomycin (Mediatech).

*DNA constructs and transfections.* Etk constructs (wt,  $\Delta$ PH, PH, E42K, and KQ) were cloned in frame into the pIRES2-eGFP bicistronic vector (ClonTech) with a T7 epitope tag. These plasmid DNA constructs were transfected into MDA-MB-435s cells by electroporation at 240V, for 2 pulses at 15-18ms using a square wave electroporator (BTX Genetronics Inc., San Diego CA). Typically, 10-20 million cells in 300 $\mu$ l -600 $\mu$ l of Opti MEM (GIBCO) were transfected with 100-150  $\mu$ g DNA. Cells were then cultured overnight in 100cm<sup>2</sup> tissue culture plates in RPMI containing 20%BCS, 20mM L-glutamine and 50 IU penicillin streptomycin (20% BCS/RPMI).

*Adhesion assays.* Standard adhesion assays were performed using cells labeled with Calcein AM (Molecular Probes) as previously described [4]. Extracellular matrix ligands were human type IV collagen (Sigma), laminin (Gibco), and human FN. For transient expression of GFP-fusion proteins, adhesion was quantitated following collection of adherent cells and analysis by flow cytometry essentially as described [4,8]. Growth factor stimulation was performed with EGF (Gibco), or HRG $\beta$  (R&D Systems).

*Flow cytometry.* Single-color flow cytometric analysis (FACS) was performed on cells in suspension after removal from tissue culture flasks with 1mM EDTA or 1X trypsin.  $5 \times 10^5$  cells were typically analyzed in FACS buffer [Hanks buffered saline solution (HBSS), containing 1% bovine calf serum (BCS; Hyclone Laboratories, Inc)]. After 2 washes in ice-cold FACS buffer, data was acquired on a Becton Dickinson FACScan or FACScalibur and analyzed using Cellquest software.

*Migration assays.* Cell lines were allowed to grow to sub-confluence (about 75-85%) prior to harvest for migration studies. Sub-confluent cell cultures were placed in serum-free media for 12-24 hours and harvested by releasing from flasks with 1 mM EDTA. After cells were washed free of EDTA in serum-free RPMI 1640 media, they were quantified and assessed for viability using trypan blue. Cells at a density of 400,000 cells/ml in assay media (RPMI, 20 mM HEPES, 0.1% BSA) were added in 57  $\mu$ l to the upper well of a 48-well chemotaxis chamber (Neuro Probe, Inc.), containing assay media or appropriate growth factor. Polycarbonate filters (8  $\mu$ m; Osmonics) were pre-coated with mouse EHS-collagen or EHS-laminin (Gibco) at 20  $\mu$ g/ml in PBS overnight at 4°C and allowed to air dry before placing in chambers. Cells were allowed to migrate in the presence or absence of stimulators for 4-6 hours at 37°C before disassembly of the chambers, fixing and staining of the migrated cells. Non-migrated cells were removed from the upper surface of the filters after placing on a microscope slide, and cell migration was quantified by counting and taking the sum of migrated cells in 4 separate fields of at least 3 individual wells. For inhibition studies, cells were pre-incubated for 15 minutes on ice with inhibitor or appropriate control prior to addition to chemotaxis chambers.

*Immunoprecipitation.* MDA-MB-435s cells were grown to ~75% confluence in 100cm<sup>2</sup> tissue culture dishes. For growth factor stimulation experiments, cells were serum starved for 6-12 hours before stimulation. Cell lysates were prepared in lysis buffer (1% Triton X-100, 1% deoxycholic acid, 158mM NaCl, 5mM EDTA, 10mM Tris pH 7.2 containing 1mM PMSF, 10ug aprotinin, 10ug/ml leupeptin, 1mM sodium orthovanadate). Cell lysis was performed on ice for 20 min and the lysates were centrifuged at 2000rpm for 5 min to remove cell debris. Immunoprecipitation was performed at 4°C overnight using polyclonal Etk antibodies, anti SH Etk and anti PH/SH Etk, or anti-phosphotyrosine mAb PY20. The immunoprecipitates were incubated with Protein-A sepharose beads for an additional 2 hours at 4° C. The resultant immunocomplexes were washed three times with ice cold RIPA buffer and then boiled for 5 min. in 2X sodium dodecyl sulfate (SDS) buffer (125mM Tris pH 6.8 containing 4% SDS, 2mM EDTA, 20% glycerol, 10% mercaptoethanol, 0.6% bromophenol blue). The samples were centrifuged at 13,000rpm for 2 min and the supernatant was separated on a 7.5%-10% gel by polyacrylamide gel electrophoresis.

*Western blotting.* Cell lysates or immunoprecipitates were separated by SDS-PAGE as described above and transferred to Immobilon-P membrane (Millipore) in transfer buffer (25 mM Tris, 192 mM glycine, 20% methanol, 0.0075% SDS) for 2 hours at 400 mA. Membranes were incubated in blocking buffer [(5% milk in PBS or for blots used for the detection of phosphotyrosine, 1% BSA in Tris buffer (10mM Tris pH 7.5, 100mM NaCl)] for 1 hour at room temperature or overnight at 4°C. Blots were washed in PBS prior to addition of primary antibodies diluted in blocking buffer (anti-phosphotyrosine mAb 4G10; UBI) for 1 hour at room temperature. Blots were rinsed 3 times in PBS, 0.1% Tween-20 for 10 minutes each before addition of secondary antibodies diluted in blocking buffer (goat anti-mouse IgG-horse radish peroxidase (GAM-IgG-HRP, Gibco) for 1 hour at room temperature. Blots were rinsed 3 times

in PBS, 0.1% TWEEN-20 and bands were visualized using enhanced chemiluminescence (Pierce Chemical). For re-probing membranes, stripping buffer (62.5 mM Tris, pH 6.8, 2% SDS, 0.1M 2-ME) was used at 55°C for 30 minutes followed by blocking membranes in 5% milk, PBS, and re-probing with appropriate antibodies.

## RESULTS AND DISCUSSION

This project is investigating the role of the Tec family tyrosine kinase Etk in mediating the pro-adhesive and pro-migratory effects of the growth factor HRG $\beta$  on breast cancer cells. We specifically hypothesize that HRG $\beta$  results in PI 3-K-dependent activation of Etk, which subsequently regulates the actin cytoskeleton, potentially via interactions with the actin regulatory protein N-WASP. Activation of Etk and other Tec family tyrosine kinases, notably Itk and Btk, is regulated by PI 3-K [9-11], which produces membrane phospholipid products that recruit these kinases to the plasma membrane [12,13]. Recent studies from our laboratory have demonstrated a function for the Tec family tyrosine kinase Itk in the regulation of  $\beta$ 1 integrin functional activity on T cells by the antigen-specific CD3/T cell receptor complex [14]. In addition, there is growing evidence that Tec family kinases play a key role in regulating the actin cytoskeleton [15,16].

The following report details our progress in each task outlined in the approved Statement of Work. As outlined in detail below, we have focused much of our work in the first year towards completing some of the tasks associated with Aim 2, due to some new findings on the role of integrins in activating Etk.

**AIM 1. TO DETERMINE THE EFFECTS OF HRG $\beta$ - AND EGF-MEDIATED ACTIVATION OF PI 3-K ON 1) TYROSINE PHOSPHORYLATION AND ACTIVATION OF ETK; AND 2) MEMBRANE RELOCALIZATION OF ETK.**

- Analyze effects of HRG $\beta$  and EGF on the tyrosine phosphorylation and activation of Etk

Our initial studies focused on the detection of endogenous Etk in MDA-MB-435s cells. This proved to be a bit more challenging than originally expected, due to the lack of suitable anti-Etk antibodies for Western blotting analysis. However, we have recently identified polyclonal anti-Etk antibodies for immunoprecipitation analysis, and a commercially available anti-Etk antibody (Transduction Labs/Pharmingen) suitable for Western blotting. Subsequent analysis examined the levels of Etk expressed in a number of cell lines including MDA-MB-435s, non-metastatic breast cancer cells MCF-7, prostate carcinoma cell lines LNCap and PC3M, as well as human endothelial vascular cells. Significant levels of endogenous Etk were detected in the metastatic carcinoma cell lines, MDA-MB-435s and the prostate carcinoma cell line PC3M, which are typically highly migratory cells. In the non metastatic cell lines LNCap and MCF-7, which do not exhibit high migration levels, Etk expression was either low or absent [17]: Fig. 1a). Recent preliminary work has shown that stimulation of MDA-MB-435s cells with HRG $\beta$  results within 5-10 minutes in increased tyrosine phosphorylation of endogenous Etk, indicative of increased Etk kinase activity (Fig. 1).

Over the past year, we have also uncovered a novel function for integrins themselves in the activation of Etk [17]. This work suggests a critical role for focal adhesion kinase in integrin-mediated activation of Etk that is dependent on the integrity of the pleckstrin homology (PH) domain of Etk. In addition, as described below, these studies also indicate a critical role for Etk in the basal migration of MDA-MB-435s breast cancer cells. These

studies have demonstrated a novel mechanism of regulation of Etk kinase activity, and provide further evidence for cross-talk between growth factor receptors and integrins, consistent with our working hypothesis.

- Determine the effects of PI 3-K inhibitors and dominant-negative p85 subunit of PI 3-K on HRG $\beta$ - and EGF-induced tyrosine phosphorylation and activation of Etk.  
This task was not addressed in the first year.
- Determine the phospholipid binding properties of Etk and the role of the PH domain of Etk in binding to phospholipids.  
We have established the assay for determining the phospholipid binding properties of Etk and the role of Etk in binding to phospholipids. Initial preliminary experiments focused on the phospholipid binding properties of the related Tec family kinase Itk [14]. These studies demonstrated binding of Itk to the PI 3-K lipid product phosphatidylinositol(3,4,5)-trisphosphate [PI(3,4,5)-P<sub>3</sub>]. Furthermore, the PH domain of Itk was both sufficient and required for Itk binding to PI(3,4,5)-P<sub>3</sub> [14]. Over the next year, we will complete this task by assessing the binding of Etk to the same panel of purified phospholipids.
- Analyze membrane recruitment of Etk upon HRG $\beta$  and EGF stimulation by membrane fractionation techniques and confocal microscopy.  
As with the task above, we have optimized the protocol for membrane fractionation of cells in order to isolate membrane microdomains. We have also developed the expertise required to visualize growth factor-dependent changes in the membrane localization of Etk by confocal microscopy. Analysis of Itk tyrosine kinase function utilizing these techniques was performed over the past year with human T cells [14]. We will utilize these approaches over the next year to analyze growth factor-dependent changes in the membrane localization of both endogenous Etk and transfected Etk in MDA-MB-435s breast cancer cells.
- Analyze the role of PI 3-K in the membrane recruitment of Etk upon HRG $\beta$  and EGF stimulation by membrane fractionation techniques and confocal microscopy  
This task was not addressed in the first year.

## AIM 2. TO DETERMINE THE ROLE OF ETK ON HRG $\beta$ - AND EGF-MEDIATED INDUCTION OF INTEGRIN ADHESIVENESS AND INTEGRIN-DEPENDENT MIGRATION OF MDA-MB-435 BREAST CANCER CELLS.

- Develop EGFP bicistronic vectors expressing wild-type and mutant forms of Etk.  
We have developed plasmid expression constructs encoding for T7 epitope-tagged forms of wild-type Etk, Etk lacking the Etk PH domain (Etk  $\Delta$ PH), a kinase-inactive form of Etk (KQ Etk) and Etk with a deletion of the glutamate residue at position 42 in the Etk PH domain (Etk 42K). As outlined in the original statement of work, we have utilized the pIRES2-EGFP expression construct, which encodes for a bicistronic message encoding for enhanced green fluorescent protein (eGFP) and the T7-tagged Etk construct. This allows us to identify the transfected cells noninvasively by eGFP expression, but without the potential complications of altering Etk function by tagging Etk with eGFP. We have successfully used this expression construct in other studies in the laboratory [18]. Analysis of the DNA clones by restriction enzyme mapping indicated that the Etk constructs of interest were successfully cloned into the pIRES2-EGFP vector. Further confirmation was obtained by Western blotting of cell lysates generated from MDA-MB-435s cells transfected with the wild-type and kinase-inactive forms of Etk (Fig.2). Since transfection of MDA-MB-435s cells with

these plasmid expression constructs results in fairly low levels of transfection efficiency (10-20%), we are also examining the potential of retroviral expression systems using mouse stem cell virus (MSCV) that have been developed in our laboratory for other studies. Preliminary results indicate that high levels of retroviral infection (~50%) can be achieved using MSCV encoding for GFP (data not shown). This level of infection is a considerable improvement over our current electroporation transfection efficiencies. Furthermore, retroviral infection does not result in the extensive cell loss that is observed with gene introduction by electroporation. We will continue to develop this new expression system in the coming year.

- Analyze effects of expression of wild-type and mutant Etk constructs on integrin-dependent adhesion and migration of MDA-MB-435 breast cancer cells.

We have utilized the eGFP-Etk bicistronic constructs described above to determine if expression of wild-type or Etk constructs modulates growth factor-induced increases in integrin-dependent adhesion and migration of MDA-MB-435s breast cancer cells. To date, we have examined the effects of kinase-inactive Etk and Etk lacking the PH domain on HRG $\beta$ -dependent increases in adhesion of MDA-MB-435s breast cancer cells to collagen (Fig. 3). The results demonstrate an inhibitory effect of kinase-inactive Etk on HRG $\beta$ -dependent increased in 435 cell adhesion to collagen. In contrast, over-expression of an Etk construct lacking the PH domain does not appreciably block HRG $\beta$ -dependent increases in integrin-dependent adhesion of MDA-MB-435s cells to collagen. These studies are ongoing with the additional constructs that have been produced during the first year. We have also utilized antisense approaches to examine the role of Etk in the migration of MDA-MB-435s breast cancer cells. MDA-MB-435s cells cultured in the presence of an antisense Etk oligonucleotide exhibited: 1) decreased expression of endogenous Etk ; and 2) diminished migration through fibronectin coated membranes when compared to cells that had been exposed to a sense oligonucleotide or control [17]; Fig. 4b). We are following up on this initial work to determine if growth factor-induced increases in breast cancer adhesion and migration are similarly affected by antisense-mediated inhibition of Etk expression. Finally, we are also initiating studies to determine if the migration of breast cancer cell lines that express negligible levels of Etk, such as MCF-7 cells [17], can be enhanced by ectopic expression of wild-type Etk.

- Analyze effects of expression of wild-type and mutant Etk constructs on expression of  $\beta$ 1 integrin activation epitopes (Months 22-24)

This task was not addressed in the first year.

- Identify domains of Etk critical for HRG $\beta$ - and EGF-mediated increases in cell adhesion and migration.

As described above, the kinase activity of Etk appears to be critical to Etk function in regulating adhesion and migration of breast cancer cells, as a kinase-inactive form of Etk blocks HRG $\beta$ -mediated increases in the adhesion of MDA-MB-435s cells to collagen (Fig. 3).

- Determine if membrane targeting of Etk is sufficient to induce increased adhesion and migration of breast cancer cells.

This task was not addressed in the first year.

**AIM 3. TO DETERMINE THE ROLE OF ETK IN REGULATING GROWTH FACTOR-INDUCED MODIFICATIONS OF THE ACTIN CYTOSKELETON IN BREAST CANCER CELLS.**

- Determine the role of Etk in regulating HRG $\beta$ - and EGF-induced polymerization of the actin cytoskeleton.  
We have established conditions for analyzing changes in actin polymerization upon growth factor stimulation by flow cytometry and by confocal microscopy [14].
- Characterize the interaction between Etk and N-WASP.  
This task was not addressed in the first year.

#### KEY RESEARCH ACCOMPLISHMENTS

- Characterized Etk expression in several breast cancer cell lines
- Demonstrated HRG $\beta$ -dependent increases in tyrosine phosphorylation of endogenous Etk in MDA-MB-435s breast cancer cells
- Established research protocols for assessment of: 1) membrane localization of Etk following growth factor receptor stimulation; 2) binding of Etk to purified phospholipids; and 3) changes in actin polymerization following growth factor receptor stimulation.
- Demonstrated an inhibitory effect of kinase active Etk on HRG $\beta$ -mediated increases in adhesion of MDA-MB-435s breast cancer cells to collagen
- Demonstrated inhibition of basal migration of MDA-MB-435s breast cancer cells following antisense-mediated inhibition of endogenous Etk expression

#### REPORTABLE OUTCOMES

##### Publications

**Chen, R., O. Kim, M. Li, X. Xiong., J.-L. Guan., H.-J. Kung ., H.Chen, Y. Shimizu and Y. Qiu.** 2001. Regulation of the PH-domain-containing tyrosine kinase Etk by focal adhesion kinase through the FERM domain. *Nature Cell Biol.* 3:439-444

**Woods, M.L., W.J. Kivens, M.A. Adelsman, Y. Qiu, A. August and Shimizu Y.** 2001. A novel function for the Tec family of tyrosine kinase Itk in activation of  $\beta$ 1 integrins by the T cell receptor. *EMBO J.* 20:1232-1244.

##### Abstracts/Presentations

**Adelsman, M.A., McCarthy, J.B. and Shimizu, Y.:** Stimulation of  $\beta$ 1 integrin function by epidermal growth factor and heregulin $\beta$  has distinct requirements for erbB2 but a similar dependence on phosphoinositide 3-OH kinase. Department of Defense Breast Cancer Research Program Meeting: Era of Hope, June 8-12, 2000.

## CONCLUSIONS

In the first year of this three year proposal, we have made substantial progress in completing the tasks outlined in the original Statement of Work. These studies have analyzed expression of endogenous Etk in several breast cancer cell lines, demonstrating a correlation between high migratory capacity and Etk expression. In addition, we have demonstrated HRG $\beta$ -dependent increases in tyrosine phosphorylation of Etk and a role for the kinase activity of Etk in regulating HRG $\beta$ -dependent increases in breast cancer cell adhesion to collagen. In addition, we developed antisense strategies to demonstrate a role for Etk in the basal migration of MDA-MB-435s breast cancer cells. Finally, we have identified a novel mechanism of regulation of Etk tyrosine kinase activity by integrin receptors that is dependent on focal adhesion kinase. Additional work has involved development of critical reagents and methodologies required for the completion of the remaining tasks in the Statement of Work in the next two years of support. We believe that the establishment of retroviral expression systems in the laboratory will facilitate progress in all aims of the project, and thus we will continue to develop this methodology and utilize it where applicable. Overall, these initial studies have provided evidence in support of our hypothesis of a function for Etk in the regulation of breast cancer cell adhesion and migration, and also uncovered some new information on how Etk function is regulated by both growth factor receptors and integrins.

## REFERENCES

1. **Ruoslahti, E.** 1999. Fibronectin and its integrin receptors in cancer. *Adv. Cancer Res.* 76:1-20.
2. **Ruoslahti, E. and F.G. Giancotti .** 1989. Integrins and tumor cell dissemination. *Cancer Cells* 1:119-126.
3. **Shaw, L.M., C. Chao, U.M. Wewer, and A.M. Mercurio.** 1996. Function of the integrin  $\alpha 6 \beta 1$  in metastatic breast carcinoma cells assessed by expression of a dominant negative receptor. *Cancer Res.* 56:959-963.
4. **Adelsman, M.A., J.B. McCarthy, and Y. Shimizu.** 1999. Stimulation of  $\beta 1$  integrin function by epidermal growth factor and heregulin- $\beta$  has distinct requirements for erbB2 but a similar dependence on phosphoinositide 3-OH kinase. *Mol. Biol. Cell* 10:2861-2878.
5. **Felding-Habermann, B., T.E. O'Toole, J.W. Smith, E. Fransvea, Z.M. Ruggeri, M.H. Ginsberg, P.E. Hughes, N. Pampori, S.J. Shattil, A. Saven, and B.M. Mueller.** 2001. Integrin activation controls metastasis in human breast cancer. *Proc. Natl. Acad. Sci. USA* 98:1853-1858.
6. **Adam, L., R. Vadlamudi, S.B. Kondapaka, J. Chernoff, J. Mendelsohn, and R. Kumar.** 1998. Heregulin regulates cytoskeletal reorganization and cell migration through the p21-activated kinase-1 via phosphatidylinositol-3 kinase. *J. Biol. Chem.* 273:28238-28246.
7. **Tan, M., R. Grijalva, and D.H. Yu .** 1999. Heregulin  $\beta 1$ -activated phosphatidylinositol 3-kinase enhances aggregation of MCF-7 breast cancer cells independent of extracellular signal-regulated kinase. *Cancer Res.* 59:1620-1625.
8. **Kivens, W.J. and Y. Shimizu.** 1998. Tracking integrin-mediated adhesion using green fluorescent protein and flow cytometry. In *Signaling through cell adhesion molecules.* J.-L. Guan, ed. CRC Press, Boca Raton, pp. 219-234.
9. **Qiu, Y., D. Robinson, T.G. Pretlow, and H.J. Kung.** 1998. Etk/Bmx, a tyrosine kinase with a pleckstrin-homology domain, is an effector of phosphatidylinositol 3'-kinase and is involved in interleukin 6-induced neuroendocrine differentiation of prostate cancer cells. *Proc. Natl. Acad. Sci. USA* 95:3644-3649.
10. **August, A., A. Sadra, B. Dupont, and H. Hanafusa.** 1997. Src-induced activation of inducible T cell kinase (ITK) requires phosphatidylinositol 3-kinase activity and the pleckstrin homology domain of inducible T cell kinase. *Proc. Natl. Acad. Sci. USA* 94:11227-11232.
11. **Schaeffer, E.M. and P.L. Schwartzberg.** 2000. Tec family kinases in lymphocyte signaling and function. *Curr. Opin. Immunol.* 12:282-288.

12. **Franke, T.F., D.R. Kaplan, and L.C. Cantley.** 1997. PI3K: Downstream AKTion blocks apoptosis. *Cell* 88:435-437.
13. **Lemmon, M.A., M. Falasca, K.M. Ferguson, and J. Schlessinger.** 1997. Regulatory recruitment of signalling molecules to the cell membrane by pleckstrin-homology domains. *Trends Cell Biol.* 7:237-242.
14. **Woods, M.L., W.J. Kivens, M.A. Adelsman, Y. Qiu, A. August, and Y. Shimizu.** 2001. A novel function for the Tec family tyrosine kinase Itk in activation of  $\beta$ 1 integrins by the T cell receptor. *EMBO J.* 20:1232-1244.
15. **Bunnell, S.C., P.A. Henry, R. Kolluri, T. Kirchhausen, R.J. Rickles, and L.J. Berg.** 1996. Identification of Itk/Tsk Src homology 3 domain ligands. *J. Biol. Chem.* 271:25646-25656.
16. **Tsoukas, C.D., J.A. Grasis, A. Keith, Ching, Y. Kawakami, and T. Kawakami.** 2001. Itk/Emt: a link between T cell antigen receptor-mediated  $Ca^{2+}$  events and cytoskeletal reorganization. *Trends Immunol.* 22:17-20.
17. **Chen, R., O. Kim, M. Li, X. Xiong, J.-L. Guan, H.-J. Kung, H. Chen, Y. Shimizu, and Y. Qiu.** 2001. Regulation of the PH-domain-containing tyrosine kinase Etk by focal adhesion kinase through the FERM domain. *Nat. Cell Biol.* 3:439-444.
18. **Epler, J.A., R. Liu, H. Chung, N.C. Ottoson, and Y. Shimizu.** 2000. Regulation of  $\beta$ 1 integrin-mediated adhesion by T cell receptor signaling involves ZAP-70 but differs from signaling events that regulate transcriptional activity. *J. Immunol.* 165:4941-4949.

## APPENDICES

### FIGURES LEGENDS AND FIGURES

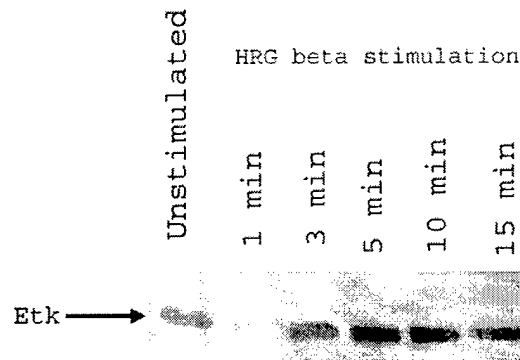

**Figure 1. HRG $\beta$  stimulation enhances tyrosine phosphorylation of endogenous Etk in MDA-MB-435s breast cancer cells.** Stimulation of  $2.5 \times 10^6$  MDA-MB-435s cells per time point was performed as described in Experimental Methods. Cell lysates were immunoprecipitated with an anti Etk antibody and western blot performed with anti phosphotyrosine mAb 4G10.

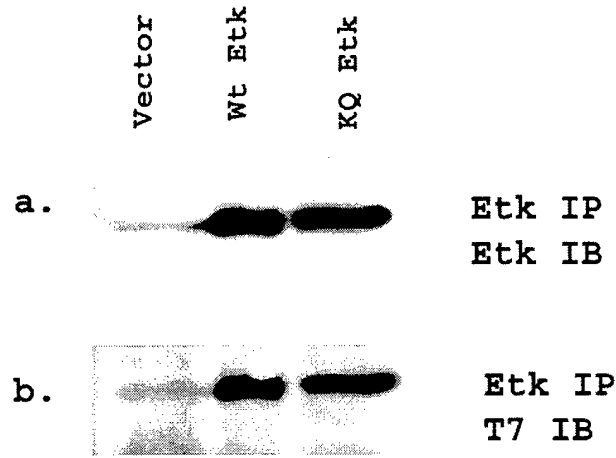

**Figure 2. Detection of transfected Etk constructs in MDA-MB-435s cells.** Cells were cultured and transfected as described in Experimental Methods. Cell lysates were immunoprecipitated with an ant Etk (SH domain) polyclonal antibody and western blot was carried out with anti Etk monoclonal antibody BMX/Etk (a). The blot was stripped and re-probed for the detection of the T7 tag with an anti T7 monoclonal antibody (b).

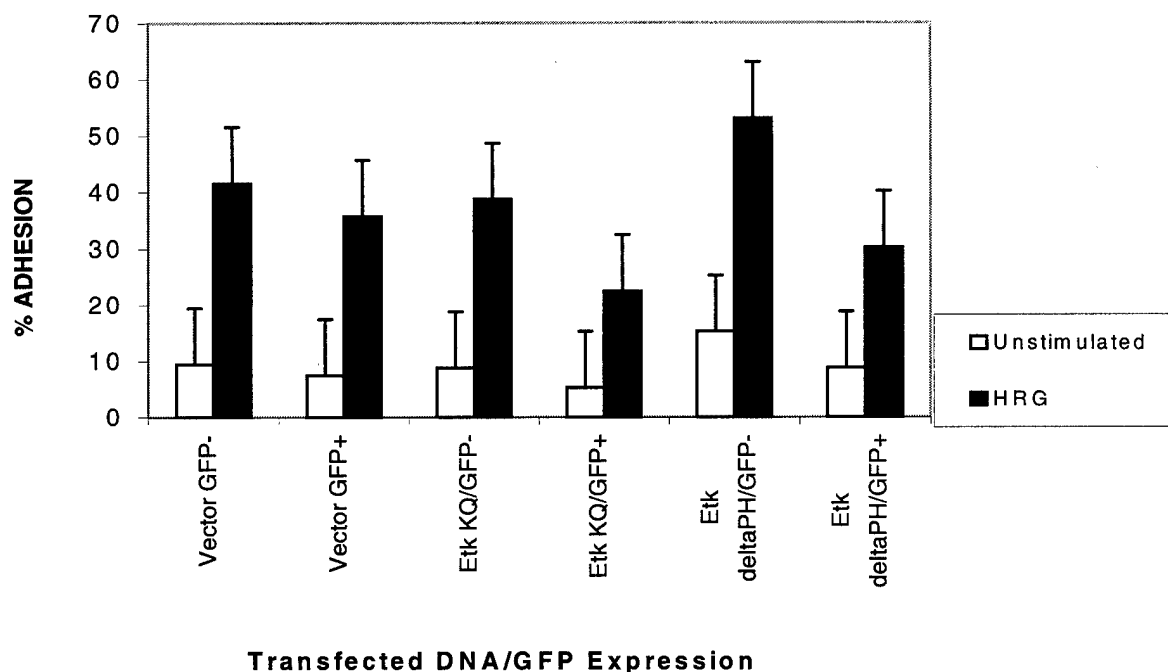

**Figure 3. Effect of HRG $\beta$  stimulation and transient transfection of Etk isoforms on MDA-MB-435s cell adhesion to collagen.** MDA-MB-435s cells were transfected with pIRES2-EGFP vector (Vector) or eGFP bicistronic vectors encoding for kinase-inactive Etk (Etk KQ) or Etk lacking the PH domain (Etk deltaPH). The cells were cultured at 37° C in 20% BCS /RPMI for 12-24 hours, then washed three times in PBS and cultured in serum free medium for and additional 12 hours. The cells were removed from the plates using 1mM EDTA and quantified using beads and GFP detection by flow cytometry as described in Experimental Methods. Cells were added to collagen-coated 96 well plates containing 100 ng/ml HRG $\beta$  or PBS (for unstimulated cells). Adhesion assays were performed and adhesion quantitated by flow cytometry as previously described [4]. Results show adhesion of GFP-negative and GFP-positive cells in each sample for unstimulated cells (open bars) and HRG $\beta$ -stimulated cells (solid bars).

# Regulation of the PH-domain-containing tyrosine kinase Etk by focal adhesion kinase through the FERM domain

Riyan Chen\*, Oekyung Kim\*, Ming Li\*, Xinsheng Xiong\*, Jun-Lin Guan†, Hsing-Jien Kung‡, Hegang Chen§, Yoji Shimizu\* and Yun Qiu\*¶

\*Departments of Laboratory Medicine and Pathology and Pharmacology, University of Minnesota, Minneapolis, Minnesota 55455, USA

†Department of Molecular Medicine, Cornell University, Ithaca, New York 14853, USA

‡Department of Biological Chemistry, University of California at Davis, School of Medicine, Sacramento, California 95817, USA

§Division of Biostatistics and Cancer Center, University of Minnesota, Minneapolis, Minnesota 55455, USA

¶e-mail: qiux009@umn.edu

**Etk/BMX, a member of the Btk family of tyrosine kinases, is highly expressed in cells with great migratory potential, including endothelial cells and metastatic carcinoma cell lines. Here, we present evidence that Etk is involved in integrin signalling and promotes cell migration. The activation of Etk by extracellular matrix proteins is regulated by FAK through an interaction between the PH domain of Etk and the FERM domain of FAK. The lack of Etk activation by extracellular matrix in FAK-null cells could be restored by co-transfection with wild-type FAK. Disrupting the interaction between Etk and FAK diminished the cell migration promoted by either kinase. Furthermore, inhibiting Etk expression in metastatic carcinoma cell lines with an antisense oligonucleotide blocks integrin-mediated migration of these cells. Taken together, our data indicate the essential role of the interaction of the PH domain of Etk and the FERM domain of FAK in integrin signalling.**

**E**tk/BMX is a member of the Bruton's tyrosine kinase (Btk) family of tyrosine kinases and contains the conserved structural motifs of these kinases—a pleckstrin homology (PH) domain and Src-homology-2 and -3 (SH2 and SH3) domains<sup>1-3</sup>. Btk, the prototype of this kinase family, is preferentially expressed in B cells and mutations of Btk are associated with the inherited human immunodeficiency disease X-linked agammaglobulinemia<sup>3</sup> (XLA). In contrast to the restricted expression of other members of this kinase family, Etk is expressed in various cell types, including endothelial cells, epithelial cells and subsets of haematopoietic cells<sup>1,2</sup>. Etk plays an important role downstream of phosphatidylinositol-3-kinase (PtdIns-3-kinase) and Src in several biological events including neuroendocrine differentiation, antiapoptosis and transformation<sup>1,4,5</sup>.

Btk kinases are thus far the only tyrosine kinase family known to contain PH domains. This domain was originally identified as an internal repeat in pleckstrin and later found in a wide variety of signalling molecules ranging from protein kinases, phospholipases and GTPases to adaptor proteins and cytoskeletal proteins<sup>6</sup>. Recently, Btk has been shown to bind to F-actin through its PH domain and promotes actin filament bundle formation *in vitro*, suggesting a role for Btk-family kinases in assembly of the cytoskeleton<sup>7</sup>.

Integrins and cytoskeleton reorganization are intimately connected. In many adherent cells, focal adhesion kinase (FAK) functions as the 'kinase domain' of integrins and is a key mediator of integrin signalling events, which control various cellular responses to extracellular matrix<sup>8,9</sup>. The amino (N) terminus of FAK shares significant sequence similarity with FERM domains, which are widespread protein modules involved in linking cytoplasmic proteins to the membrane<sup>10,11</sup>. The exact function of the FERM domain of FAK remains to be elucidated, although a recent study has shown that it is involved in an interaction of FAK with activated epidermal growth factor receptor<sup>12</sup>.

Here, we report that Etk mediates integrin signalling in both endothelial and epithelial cells, and promotes cell migration. The

activation of Etk by extracellular matrix is regulated by FAK through the interaction between the PH domain of Etk and the FERM domain of FAK. Our results provide a novel mechanism by which PH-domain-containing tyrosine kinases are regulated by integrin mediated signalling events.

## Results

**Modulation of Etk by extracellular matrix.** We examined the expression of Etk in a panel of cell lines by western blot. As shown in Fig. 1a, the expression level of Etk is much higher in endothelial (HUVEC), metastatic prostate carcinoma (PC3M) and breast carcinoma (MB-435S) cells than in non-metastatic prostate carcinoma (LNCaP) and breast carcinoma (MCF7) cells. The PC3M and MB-435S cell lines are well known as highly migratory cells that respond to stimuli such as extracellular matrix proteins and growth factors, whereas LNCaP and MCF7 have very poor motility both *in vitro* and in nude mice<sup>13,14</sup>.

The correlation between Etk expression level and migratory potential suggests a role for Etk in the regulation of cell motility, and this prompted us to test whether Etk is modulated by integrins. HUVECs were plated on coverslips coated with either polylysine or fibronectin. As shown in Fig. 1b, HUVECs do not spread very well on a polylysine-coated coverslip and Etk is diffusely distributed in the cell with strong perinuclear staining. Upon fibronectin stimulation, a significant amount of Etk is translocated to the cell membrane and the cell exhibits strong Etk staining at the cell membrane periphery, resembling membrane ruffles in which the actin filaments are enriched (indicated by arrows). We also examined the location of FAK, another tyrosine kinase that has been shown to be regulated by integrins. There is also FAK staining at membrane ruffles (arrows) in addition to the typical adhesion complexes (arrowheads) throughout the cell (Fig. 1c).

When we merged the Etk staining with that of FAK, Etk and FAK were both found to be mainly located at membrane ruffles, suggesting a possible interaction of Etk and FAK during membrane

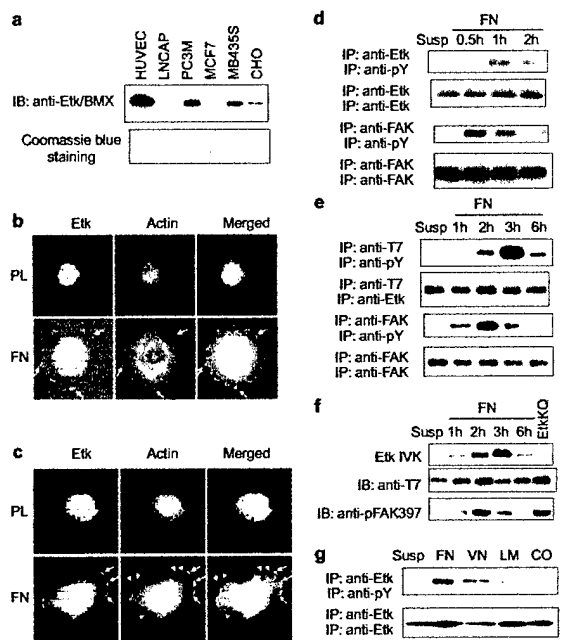

**Figure 1 Regulation of Etk by integrins.** **a**, Expression profile of Etk in different cell lines. 50  $\mu$ g total cell lysates of each indicated cell type were separated by SDS-PAGE, followed by immunoblotting with a monoclonal antibody specific for Etk/BMX (Transduction Laboratories; top). The same blot was stained with Coomassie Blue to monitor the sample loading (bottom). **b**, Translocation of Etk to membrane ruffles in response to fibronectin. HUVEC cells were plated on the coverslips coated with either 10  $\mu$ g ml<sup>-1</sup> polylysine (PL) (Sigma) or 10  $\mu$ g ml<sup>-1</sup> fibronectin (FN) (Sigma) for 2 h in serum-free medium, and then fixed and stained with anti-Etk antibody and FITC-conjugated phalloidin. This was followed by confocal microscopy as described in Methods. The arrows indicate the membrane ruffles. Yellow shows the colocalization of Etk and F-actin. **c**, Colocalization of Etk and FAK at membrane ruffles. Cells were treated as in **b**, except that an anti-FAK antibody was used. The arrowheads point at focal adhesions and the arrows indicate membrane ruffles. Yellow shows the colocalization of Etk and FAK. **d**, Tyrosine phosphorylation of endogenous Etk in response to fibronectin. HUVEC cells were plated on fibronectin-coated (FN-coated) plate for the time indicated and then lysed. Immunoprecipitations using Etk or FAK antibodies were performed and followed by immunoblotting with an anti-phosphotyrosine antibody. Suspension cells (Susp) were used as a control. **e**, Tyrosine phosphorylation of T7-tagged Etk in response to fibronectin. This was carried out in the same way as **d**, except that LNCaP cells expressing T7-tagged Etk were used. **f**, *In vitro* kinase (IVK) assays of Etk. Etk were immunoprecipitated by anti-T7 antibody from LNCaP cells stably expressing T7-tagged Etk in the suspension (Susp) or attached to FN for the indicated time (as in **e**) and then IVK assays were performed as described in Methods. LNCaP cells expressing T7-tagged Etk kinase-dead mutant (EtkKQ) were plated on FN for 3 h and serve as a control. The <sup>32</sup>P-labelled Etk is visualized by autoradiography. The autophosphorylation of FAK was monitored by western blot with anti-pFAK397 antibody (bottom). **g**, HUVEC cells were allowed to attach to the plates coated with FN, vitronectin (VN), laminin (LM) or type-I collagen (CO), or kept in suspension (Susp) for 1 h. The tyrosine phosphorylation of Etk in these cells was determined as in **d**.

ruffling rather than focal adhesion complex formation. To determine whether the membrane translocation of Etk has any effect on its kinase activity, we analysed the tyrosine phosphorylation of Etk in response to fibronectin using FAK as a control. Figure 1d shows that, upon attachment to fibronectin, the tyrosine phosphorylation of Etk becomes detectable within 30 min, when tyrosine phosphorylation

of FAK is maximal. This suggests that FAK phosphorylation is an earlier event in response to extracellular matrix and that Etk might be a downstream effector of FAK. The time gap between the peak activity of Etk and FAK suggests that multiple upstream events might be required for maximal activation of Etk, and that FAK could function at the initial step.

Similar results were obtained when we examined the ectopically expressed Etk in the human prostate carcinoma cell line LNCaP. However, the phosphorylation of both FAK and Etk is delayed about 1 h in LNCaP compared with HUVEC (Fig. 1e), which is consistent with our observation that it usually takes longer for LNCaP to attach to fibronectin. Furthermore, the increased tyrosine phosphorylation of Etk is correlated with its kinase activity, as shown by increased Etk autophosphorylation in an *in vitro* kinase assay (Fig. 1f). Taken together, these data indicate that Etk is translocated to the cell membrane and activated upon cell adhesion to extracellular matrix. The activation of Etk by matrix proteins is not limited to fibronectin, as the other tested matrix proteins such as vitronectin, laminin and type-I collagen can also induce tyrosine phosphorylation of Etk (Fig. 1g), suggesting that Etk could serve as a common signal transducer in response to extracellular matrix.

**Etk is directly associated with FAK both *in vivo* and *in vitro*.** The colocalization of Etk and FAK at membrane ruffles prompted us to examine whether Etk is associated with FAK. As shown in Fig. 2a, a tyrosine phosphorylated protein of ~130 kDa is immunoprecipitated with Etk in HUVECs upon fibronectin stimulation, and this protein can be recognized by an anti-FAK antibody, suggesting that endogenous Etk and FAK might form a complex. To define the sequence requirement of Etk for this interaction, we expressed haemagglutinin (HA)-tagged FAK with T7-tagged Etk (see Methods) and various Etk deletion mutants in cell line 293. Immunoprecipitations were performed with anti-T7 antibody and followed by western blotting with anti-FAK antibody. As shown in Fig. 2b, FAK is precipitated along with wild-type Etk, Etk- $\Delta$ SH3, Etk- $\Delta$ SH2 or Etk- $\Delta$ SH, but not with Etk- $\Delta$ PH. Furthermore, the PH domain of Etk alone is sufficient to bring down FAK but the SH2 or SH3 domain alone does not. The same results were obtained when we mixed immunoprecipitated FAK with purified glutathione-S-transferase (GST) fusion proteins containing each domain of Etk and performed precipitation experiments (Fig. 2c). These results indicate that the PH domain of Etk is required for its association with FAK.

We also tested a panel of FAK deletion mutants to delineate the interaction between FAK and the PH domain of Etk (Fig. 2d). First, three fragments of FAK (FAK-F (containing only the FERM domain), FAK-K (containing only the kinase domain) and FAK-C (containing only the carboxy-terminal domain) were tested in precipitation experiments. Only the FAK-F is associated with Etk and this interaction seems to be specific for the FERM of FAK because we could not detect any association between the JAK3 FERM domain and Etk (data not shown). We further narrowed the interaction site down to the first 127 amino acids of the FERM domain of FAK (FAK-N), which is thought to be the first lobe of FERM domains<sup>15</sup>. Deletion of these amino acids completely abolished the interaction between FAK and Etk. To eliminate the possible involvement of other protein(s) in this interaction, we also performed GST pull-down assays by mixing purified GST fusion proteins containing FAK-N and the FAK FERM domain with purified His-T7-tagged Etk PH domain. As shown in Fig. 2e, purified His-T7-tagged Etk PH domain is associated with GST-FAK-N and GST-FERM but not GST. Taken together, these data indicate that the association of FAK and Etk depends on the PH domain of Etk and the FERM domain of FAK.

**FAK promotes Etk activity.** To determine whether the association of Etk with FAK could contribute to the activation of Etk activity, we expressed Etk with wild-type FAK and with FAK mutants in 293 cells and examined their effects on Etk activity. As shown in Fig. 3a, overexpression of wild-type FAK significantly increases the tyrosine

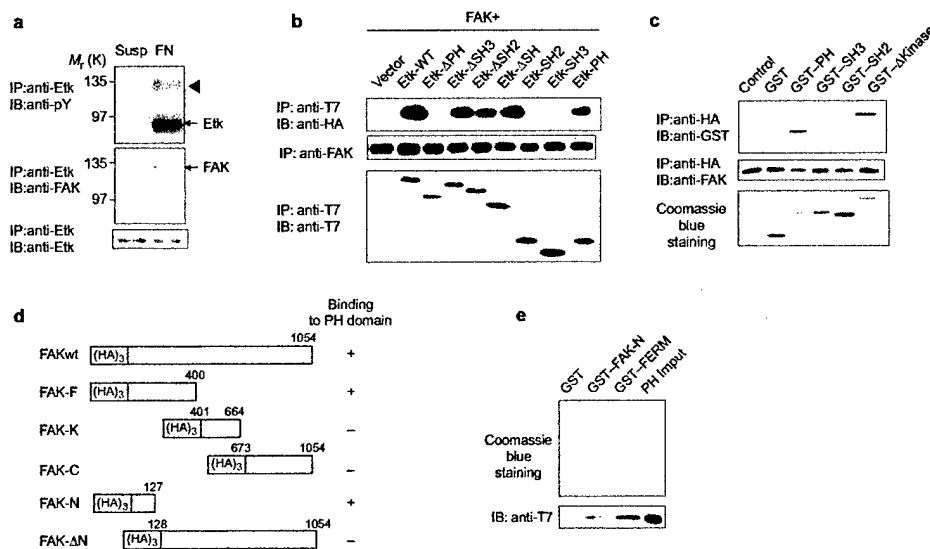

**Figure 2 PH domain of Etk and FERM domain of FAK are involved in interaction between Etk and FAK.** **a**, Co-precipitation of FAK with Etk in HUVEC cells. HUVEC cells were plated on fibronectin-coated (FN-coated) dish for 1 h or kept in suspension in serum-free medium. The cell lysates were subjected to immunoprecipitation with anti-Etk antibody followed by immunoblotting with anti-phosphotyrosine (top), anti-FAK (middle) or anti-Etk (bottom) antibody. The arrowhead indicates the tyrosine-phosphorylated protein associated with Etk. **b**, The PH domain of Etk is necessary and sufficient for binding to FAK. Haemagglutinin-tagged (HA-tagged) wild-type FAK was co-expressed with T7-tagged Etk or Etk mutants in 293 cells. Immunoprecipitations were performed with anti-T7 antibody and followed by immunoblotting with anti-HA antibody. The bottom panels show comparable expression level of FAK and Etk mutants in each immunoprecipitation experiment. **c**, FAK binds to the PH domain of Etk *in vitro*. Immunoprecipitated FAK was mixed with purified bacterially expressed glutathione-S-transferase (GST) fusion proteins containing each domain of Etk and incubated in RIPA buffer for additional 2 h followed

by extensive washing. The immunoprecipitated GST fusion proteins were detected by immunoblotting with anti-GST antibody. The bottom panels show the inputs of FAK and GST fusion proteins in each immunoprecipitation experiment. **d**, The first lobe of the FERM domain of FAK is involved in interacting with the PH domain of Etk. A series of FAK deletion mutants were co-expressed with the PH domain of Etk in 293 cells and tested for their binding to it as in **a**. The sequence of each fragment was expressed by the number of amino acid residues of chicken FAK. +, detectable association with PH domain; -, undetectable association with PH domain. **e**, Direct interaction of purified PH domain and FERM domain. The *in vitro* binding assays of purified GST fusion proteins and His-T7-tagged PH domain were performed as described in Methods. The purified GST fusion proteins associated with glutathione beads and the input of the purified His-T7-tagged PH domain protein were resolved on SDS-PAGE and stained with Coomassie Blue (top). The proteins associated with GST fusion proteins were determined by western blot with anti-T7 antibody (bottom).

phosphorylation of Etk, whereas its homologue pyk2 has little effect on Etk. FAKY397F, which lacks the major autophosphorylation site, does not activate Etk, suggesting that phosphorylation of Y397 is required for Etk activation and that proteins associated with phosphorylated Y397 such as Src or PtdIns-3-kinase are possibly involved in Etk activation. Interestingly, FAK D395A, which lacks the ability to bind to the p85 subunit of PtdIns-3-kinase<sup>16</sup>, can still activate Etk to a comparable extent to wild-type FAK, suggesting that the activation of Etk by FAK is independent of FAK-associated PtdIns-3-kinase. This is consistent with our observation that the dominant negative PtdIns-3-kinase mutant p85A, which inhibits Etk activation induced by interleukin-6 (ref. 1), does not block Etk activation by FAK (data not shown).

We also tested a panel of Etk mutants with a point mutation at several highly conserved residues in the PH domain or potential tyrosine phosphorylation sites. The lipid-binding-deficient mutant EtkR29N can still bind to (Fig. 3c) and be readily activated by (Fig. 3b) FAK, indicating that the regulation of Etk by FAK is independent of the lipid binding activity of the PH domain. By contrast, activation of EtkE42K by FAK is virtually lost (Fig. 3b), possibly owing to the poor binding of this mutant to FAK (Fig. 3c). Although the substitution of a series of tyrosine residues in Etk with phenylalanines has little effect on Etk activation by FAK, the mutation of tyrosine at position 40 dramatically diminishes Etk activation by FAK, even though it binds to FAK as well as wild-type Etk does (Fig. 3b,c). These data suggest that

Y40 might be a phosphorylation site for FAK or FAK-associated tyrosine kinase(s), and its phosphorylation could be essential for Etk activation by FAK. They also indicate that both Y40 and E42 of the PH domain are involved in regulation of Etk activity by FAK.

Furthermore, we examined whether the association between Etk and FAK is essential for Etk activation by integrins. As shown in Fig. 3d, the attachment of cells to fibronectin induces tyrosine phosphorylation of Etk. The tyrosine phosphorylation of Etk is dramatically enhanced when it is coexpressed with FAKD395A but completely abolished in the presence of FAK-N, suggesting that FAK-N can compete with endogenous FAK to bind to Etk and to inhibit Etk activation by FAK in response to cell adhesion. To investigate further the requirement of FAK for Etk activation by fibronectin, we introduced T7-tagged Etk with the vector control, FAK, kinase-inactive FAK or the mutant FAKΔN into FAK<sup>-/-</sup> fibroblast cells<sup>17</sup>. Figure 3e shows that, in FAK<sup>-/-</sup> cells, fibronectin can no longer induce tyrosine phosphorylation of Etk. Co-transfection of Etk with wild-type FAK can restore the Etk activity in response to fibronectin but not the kinase-dead FAK or FAKΔN, suggesting that the kinase activity of FAK is required for Etk activation. Taken together, these data indicate that Etk activity is modulated by FAK through an interaction between the PH domain of Etk and the FERM domain of FAK.

**Etk promotes integrin-mediated cell migration.** To investigate whether Etk plays a role in regulating cell migration, the transwell

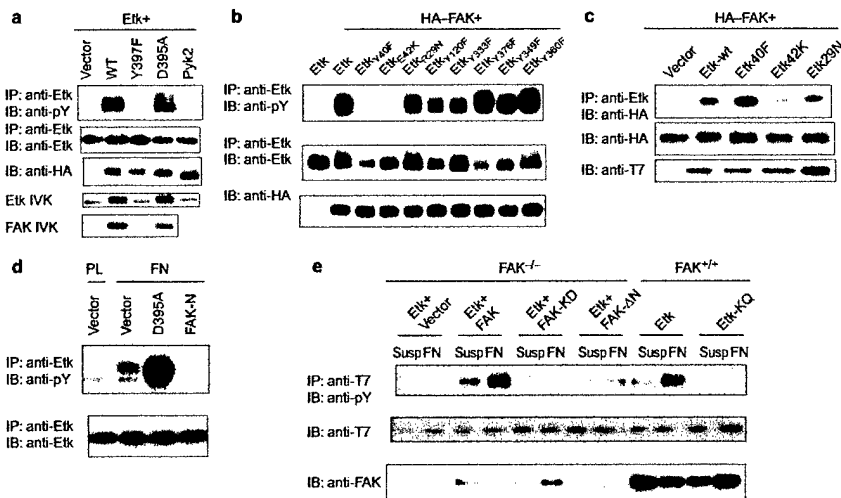

**Figure 3 Activation of Etk by FAK.** **a**, FAK promotes Etk activity. Etk was co-expressed with a vector control and with haemagglutinin-tagged (HA-tagged) wild-type FAK (WT), FAK mutants Y397F and D395A, and *pyk2* in 293 cells. At 24 h after transfection, the cells were serum starved for 24 h and then lysed. The cell lysates were immunoprecipitated (IP) with anti-Etk antibody and then immunoblotted (IB) with the indicated antibodies (anti-pY, anti-phosphotyrosine antibody). Expression of the transfected FAK, FAK mutants and *pyk2* were determined by immunoblotting with anti-HA antibody. Autophosphorylation of FAK or Etk was determined by *in vitro* kinase (IVK) assays as described in Methods. **b**, The Y40 and E42 residues of Etk are important for the regulation of its activity by FAK. The HA-tagged FAK was co-expressed with Etk or Etk mutants containing point mutation at the indicated positions. The effects of FAK on Etk and its mutants were determined as in **a**. **c**, The association of Etk mutants with FAK. Co-immunoprecipitation experiments of Etk mutants with FAK were performed as in **a**. **d**, FAK-N blocks Etk activation induced by fibronectin. Etk was co-transfected with vector control, FAKD395A or FAK-N into 293 cells. At 48 h after transfection, cells were plated on polylysine (PL) or

fibronectin (FN) coated plates for 2 h and then lysed. Immunoprecipitations were performed with anti-Etk antibody, followed by immunoblotting with anti-phosphotyrosine antibody. **e**, Requirement of FAK for Etk activation in response to fibronectin. T7-tagged Etk was transfected into FAK<sup>-/-</sup> fibroblast cells with vector control, FAK, kinase-inactive FAK (FAK-KD) or FAK-ΔN. At 24 h after transfection, the cells were trypsinized and replated on fibronectin-coated dishes for 1 h or kept as a suspension. Etk or kinase-inactive Etk (Etk-KQ) were also transfected into FAK<sup>-/-</sup> cells and treated in the same way to serve as controls. The cells were then lysed and the lysates were subjected to immunoprecipitation with anti-T7 antibody followed by anti-phosphotyrosine (top). The expression level of transfected Etk was monitored by immunoblot with anti-T7 antibody (middle). The expression level of FAK was determined by immunoblot with anti-FAK antibody (bottom). (The transfection efficiency in these fibroblasts is about 15% and so the expression level of FAK in those FAK<sup>-/-</sup> cells transfected with FAK or FAK-KD should be comparable to that of the endogenous FAK in FAK<sup>-/-</sup> cells.)

chamber assay was used to examine the motility of cells overexpressing Etk or its mutants; FAK, which promotes cell migration in CHO cells<sup>18</sup>, was used as a positive control. As shown in Fig. 4a, overexpression of wild-type Etk results in a threefold increase in cell motility over the vector control. The lipid-binding-deficient mutant EtkR29N can still enhance migration as the wild type does but the Etk mutants EtkY40F and EtkE42K have almost lost their ability to promote cell migration, which is consistent with their lack of activation by FAK. Expression of Etk with FAK-N, which inhibits Etk activation by fibronectin, significantly reduces Etk-promoted migration. Expression of FAK with the PH domain of Etk significantly inhibits the cell migration induced by FAK, but the mutated PH domain containing E42K mutation can barely do so, possibly owing to the E42K mutant binding poorly to FAK.

The lipid-binding-deficient PH domain (R29N) can still attenuate cell migration induced by FAK as efficiently as the wild-type PH domain, and the AH domain of Akt, another phospholipid binder, has little effect on FAK-promoted migration. Thus, it is more likely that the PH domain of Etk inhibits FAK function by competing with endogenous Etk for binding to FAK than by exclusively sequestering phospholipids, which are required for cell migration. Taken together, our results suggest that the interaction between the PH domain of Etk and the FERM domain of FAK is required for integrin-mediated cell migration.

To show further that Etk plays an essential role in integrin signalling, we tested the effect of an antisense oligonucleotide against

Etk on cell migration. As shown in Fig. 4b, treating metastatic carcinoma PC3M and MB-435S cells with this oligonucleotide results in significant reduction of Etk protein expression in these cells. The diminished Etk protein expression is associated with dramatic inhibition of the motility of these cells. By contrast, a control sense oligonucleotide of Etk has little effect on the motility of these cells. These data indicate that Etk plays an indispensable role in integrin-mediated migration of these cells.

**Discussion**

In this report, we have shown that the PH-domain-containing tyrosine kinase Etk mediates the cellular response to extracellular matrix by associating with FAK in endothelial and epithelial cells. The activation of Etk by matrix depends on the interaction between the PH domain of Etk and the FERM domain of FAK. Unlike other proteins associated with FAK, such as Src, PtdIns-3-kinase and p130Cas, neither the SH2 nor the SH3 domain of Etk is required for interaction with FAK. To our surprise, the PH domain of Etk plays a major role in its association with FAK and this interaction seems to be direct and can be reproduced by *in vitro* binding assays using purified recombinant *Escherichia coli* expressed PH domain and FERM domain.

The activation of Etk by FAK promotes cell migration. Our observations raise the possibility that Etk is a downstream effector of FAK in addition to Src and PtdIns-3-kinase, as previously

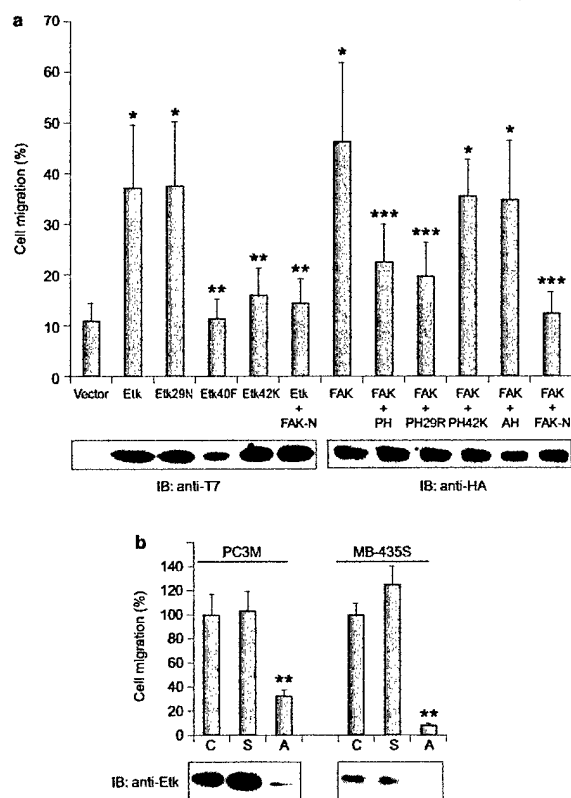

**Figure 4 Etk is essential for integrin-mediated cell migration.** **a**, Etk promotes cell migration. The Etk or FAK constructs were transfected with a green fluorescent protein (GFP) marker into CHO cells. At 48 h after transfection, migration assays were performed as described in Methods. Means of GFP positive cell counts from at least eight randomly selected fields from three independent experiments were determined and normalized with the transfection efficiency. The data were expressed as the percentage of cells that had migrated to the lower chamber of the transwell. A fraction of the cells were also lysed, followed by immunoblotting with anti-T7 or anti-HA antibody to monitor the expression of Etk and FAK (bottom). Error bars represent S.D. \*,  $P < 0.001$  compared with vector control; \*\*,  $P < 0.001$  compared with sample Etk; \*\*\*,  $P < 0.001$  compared with sample FAK. **b**, An antisense oligonucleotide against Etk blocks cell migration induced by fibronectin. PC3M and MB-435S cells were treated with 10  $\mu$ M sense (S) or antisense (A) oligonucleotides of Etk for 24 h or left untreated (C). The cells were then used for migration assays. The migration of untreated cell (C) was set as 100%. \*\*,  $P < 0.001$  compared with C and S. A proportion of the cells were also lysed and immunoblotted with Etk antibody to monitor the expression of Etk (bottom).

reported<sup>1,5</sup>. Although the activation of Etk by FAK appears to require neither the lipid binding activity of Etk nor the PtdIns-3-kinase associated with FAK, optimal activation of Etk could be achieved by the synergism of these three upstream kinases (Y. Qiu, unpublished data). The PH domains of Btk family kinases have been shown to bind to phospholipids and several other signalling or structural proteins such as G-protein  $\beta$  subunits, protein-kinase-C isoforms, Stat3 and F-actin<sup>5,7,19,20</sup>. Here, we have shown that FAK is another important signalling molecule, interacting with the PH domain of Etk in response to extracellular matrix.

The interactions between PH domains and different signalling molecules are probably dynamic and spatially restrained. This is

supported by our immunostaining experiments, which showed that Etk and FAK are colocalized only at membrane ruffles. The sequence requirement for Etk interacting with FAK has yet to be determined, although our data suggest that the region around the glutamate residue at position 42 (E42) might be involved; this appears to be different from the sequence element necessary for interacting with F-actin, which contains only ten amino acids (residues 11–20) of Btk. E42 of Etk is highly conserved among the PH domains of Btk family kinases. The equivalent mutation in Btk (E41K) leads to its constitutive activation, accompanied by increased membrane localization<sup>21</sup>. Although Btk E41 has been proposed to be close to the lipid binding site<sup>22</sup>, the effect of this mutation on the lipid binding affinity of its PH domain remains to be determined. In the case of Etk, the E42K mutation has no significant effect on the lipid binding activity of the PH domain as determined by FAT-western assays (Y. Qiu, unpublished data). Our results imply that this glutamate residue is more likely to be involved in protein–protein interactions, because EtkE42K binds poorly to FAK and loses virtually all kinase activity. These results suggest that the critical role of this glutamate residue is regulating the activity of Btk family kinases.

The tyrosine residue Y40 in the PH domain of Etk is also conserved among all Btk family kinases and the equivalent mutation of Btk is found to associate with XLA. The Y40F mutation significantly diminishes the tyrosine phosphorylation of Etk induced by FAK without affecting its association with FAK, suggesting that Y40 might be a phosphorylation site and that its phosphorylation could be required for Etk activation. Our preliminary data from phosphopeptide mapping by mass spectrometry indicate that Y40 is phosphorylated when Etk is expressed with FAK (R. Chen and Y. Qiu, unpublished data). However, whether FAK or FAK-associated kinase(s) such as Src are responsible for this phosphorylation has yet to be determined.

Moreover, in FAK-null cells, the activation of Etk by integrins is abrogated although expression of Pyk2, a close homologue of FAK<sup>23</sup>, is elevated. The Etk activity can be restored by transfection of wild-type FAK but not kinase-dead FAK. Our results strongly argue that FAK is one upstream kinase that is required for activation of Etk by integrins. The relatively slower activation of Etk in comparison with FAK suggests that optimal activation of Etk might be a multistep process and require several upstream activators. The D395A mutant of FAK can still stimulate Etk activity but the Y397F mutant does not, suggesting that Src might also be involved in the activation of Etk by integrins.

In fact, the activation of Btk family kinases by direct phosphorylation by Src family kinases has been well documented<sup>5,24</sup>. Our current model for activation of Etk by integrins is that the interaction between the PH domain of Etk and the FERM domain of FAK might lead to conformational change of the PH domain and phosphorylation of Y40 concomitant with the membrane translocation of Etk, which resembles the effects of phospholipid binding to the PH domains of Btk family kinases in response to growth factors or cytokines. This will open up the 'closed' conformation of the inactive Etk and the potential phosphorylation site Y566 located in its kinase domain, which is originally masked by the PH domain, will become accessible to FAK-associated Src kinase<sup>5,25,26</sup>. Consequently, phosphorylation of Y566 by Src results in activation of Etk kinase<sup>5</sup>. Our results have provided a novel mechanism by which the PH-domain-containing kinases could be activated by binding to FERM domains. Given that Etk is highly expressed in endothelial cells and metastatic carcinoma cells, we anticipate that Etk might be a target for antiangiogenesis and anticancer therapies. □

## Methods

### Cell culture, plasmids and transfection.

All carcinoma cell lines (American Type Culture Collection, Rockville, MD, USA) were maintained in RPMI 1640 medium with 10% foetal bovine serum (FBS); 293 and cos-1 cells were maintained in DMEM medium with 10% FBS. HUVEC cells were purchased from the Endothelial Cell Culture

Facility (University of Minnesota, USA) and maintained in M199 medium containing 20% FBS and 0.2 µg ml<sup>-1</sup> EndoGrow (Vec-Tech). FAK<sup>-/-</sup> and FAK<sup>-/-</sup> fibroblasts were kindly provided by D. Ilic and C. Damsky (University of California at San Francisco, USA). Transfections were performed using Eugene 6 (Roche) according to the manufacturer's instructions. The LNCaP stable cell line expressing T7-tagged Etk was maintained in RPMI 1640 medium containing 600 µg ml<sup>-1</sup> G418 as previously reported<sup>4</sup>.

**DNA constructs and antibodies.**

T7-tagged Etk and its mutants were cloned in pcDNA3 vector as described previously<sup>15</sup>. HA-tagged FAK and *pyk2* constructs were used as described previously<sup>17,28</sup>. All deletion and point mutation mutants were generated by a PCR-based method and confirmed by sequencing<sup>4</sup>. Anti-T7 antibody was purchased from Novagen. Anti-HA antibody was from Babco. Monoclonal antibodies against FAK and Etk/BMX were from Transduction Laboratories. Polyclonal Etk antibody was developed as described<sup>4</sup>.

**Immunoprecipitation, western blot and *in vitro* kinase assay.**

The cells were lysed using modified RIPA buffer (50 mM HEPES pH 7.4, 150 mM NaCl, 10% glycerol, 1.5 mM MgCl<sub>2</sub>, 1 mM EGTA, 1 mM sodium vanadate, 10 mM sodium pyrophosphate, 100 mM NaF, 1% Triton X-100, 1% sodium deoxycholate, 0.1% SDS, 10 µg ml<sup>-1</sup> Leupeptin, 10 units ml<sup>-1</sup> aprotinin, and 1 mM phenylmethylsulfonyl fluoride). The insoluble material was removed by centrifugation. Antibodies were then added to the lysate and incubated for 1 h at 4 °C. In some cases, antibodies covalently coupled to agarose beads were used.

Antibodies were collected with protein-A-sepharose or protein-G-sepharose beads, and immuno complexes were washed at 4 °C in Triton-only lysis buffer (RIPA lysis buffer without SDS and sodium deoxycholate) and followed by washing in HNTG buffer (50 mM HEPES pH 7.4, 150 mM NaCl, 0.1% Triton X-100, 10% glycerol) before direct analysis by SDS-polyacrylamide gel electrophoresis (PAGE) or *in vitro* <sup>32</sup>P labelling.

Immunoblotting was performed as previously described<sup>4</sup>. Briefly, blots were incubated with either 1 µg ml<sup>-1</sup> anti-phosphotyrosine (4G10; UBI) monoclonal or polyclonal antibodies, 1 : 5000 dilution of anti-HA tag (Babco), and 1 : 1000 dilutions of either at 4 °C. The bound primary antibody was visualized by enhanced chemiluminescent detection (Amersham Life Science). The bound antibodies were stripped off membranes by 5 M sodium iodide at room temperature for 30 min. Before reprobing with different primary antibodies, stripped membranes were washed extensively in TBST (10 mM Tris pH 7.6, 150 mM NaCl, 0.1% Tween 20) and placed in blocking buffer (TBST containing 3% bovine serum albumin) for 1 hr at room temperature.

For *in vitro* kinase assays, the immunoprecipitated FAK or Etk was incubated in 25 µl kinase buffer [50 mM HEPES pH 7.4, 10 mM MnCl<sub>2</sub>, 1 mM DTT, 10 mM ATP (4,500 Ci mmol<sup>-1</sup>)] with or without exogenous substrate for 20 min at room temperature. Reactions were stopped by adding an equal volume of 2x Laemmli sample buffer, and protein phosphorylation was assessed by SDS-PAGE and followed by autoradiography.

***In vitro* binding assays.**

GST fusion proteins and His-T7-tagged proteins were expressed in bacteria and purified by using glutathione sepharose (Pharmacia) or Ni<sup>2+</sup> column (Novagen) as recommended by the manufacturers. HA-tagged FAK was immunoprecipitated with monoclonal anti-HA antibody (Babco) and then mixed with 500 ng GST fusion proteins or GST alone. The incubations were 2 h at 4 °C in modified RIPA buffer with rotation. The beads were washed twice with modified RIPA buffer and HNTG buffer. The proteins associated with FAK were eluted by boiling in Laemmli sample buffer, resolved by SDS-PAGE and analysed by western blotting with anti-GST antibody. In the direct binding experiments, the purified GST fusion proteins remained on the glutathione sepharose beads and were then mixed with purified His-T7-tagged PH domain in PBS containing 0.5 mg ml<sup>-1</sup> bovine serum albumin. After overnight incubation, the beads were collected and extensively washed with cold PBS. The bound proteins were analysed by SDS-PAGE followed by western blot with anti-T7 antibody.

**Immunofluorescence staining.**

The cells were treated as indicated, then fixed in 3.7% paraformaldehyde for 15 min and permeabilized for 5 min in 0.2% Triton-X100. The coverslides were washed and blocked as recommended (Molecular Probe). Mouse anti-T7 monoclonal antibody (10 µg ml<sup>-1</sup>) was added and incubated for 1 h at room temperature. Then, 1 unit ml<sup>-1</sup> of rhodamine phalloidin was added and incubated for 20 min at room temperature. The coverslides were washed four times with PBS and mounted. Control stainings were performed without primary or secondary antibodies. The cells were examined in an inverted microscope under a 60x oil immersion objective and a Bio-Rad laser confocal microscope system (MRC-1024) with Lasersharp acquisition software (Bio-Rad).

**Cell migration assays.**

The cells were harvested as described earlier and resuspended in serum free medium for 30 min. The cells were loaded into the insert (8 µm pore size) of a Boyden chamber (Costar) and 10 µg ml<sup>-1</sup> fibronectin (Sigma) were added into the bottom chamber. After 6 h incubation at 37 °C in a 5% CO<sub>2</sub> incubator, the cells were fixed and stained by using the Diff-Quik system. The cells on the top of the filter were removed with a cotton-tipped applicator and the migrated cells attached to the lower surface of the membrane were counted in at least eight randomly selected fields under a microscope. For migration assays of CHO cells shown in Fig. 4a, the green-fluorescent-protein-positive cells in the transwell were counted directly under an inverted fluorescence microscope after removing the cells on the top without further fixing or staining. The transfection efficiency of the plasmids was determined

by the number of GFP positive cells in the total cell population. The sequence of antisense oligonucleotide is 5'-CTAGAATAGATTGTGATCCATATTATCAT-3'. The sequence of sense oligonucleotide is 5'-ACCATGGATACAAAATCTATCTAG-3'. Statistical analysis was performed using Student's *t* test.

RECEIVED 19 JULY 2000; REVISED 21 DECEMBER 2000; ACCEPTED 8 JANUARY 2001; PUBLISHED 30 MARCH 2001

1. Qiu, Y., Robinson, D., Pretlow, T. G. & Kung, H. J. Etk/Bmx, a tyrosine kinase with a pleckstrin-homology domain, is an effector of phosphatidylinositol 3'-kinase and is involved in interleukin 6-induced neuroendocrine differentiation of prostate cancer cells. *Proc. Natl Acad. Sci. USA* 95, 3644-3649 (1998).
2. Tamagnone, L. et al. BMX, a novel nonreceptor tyrosine kinase gene of the BTK/ITK/TEC/TXK family located in chromosome Xp22.2. *Oncogene* 9, 3683-3688 (1994).
3. Rawlings, D. J. & Witte, O. N. The Btk subfamily of cytoplasmic tyrosine kinases: structure, regulation and function. *Semin. Immunol.* 7, 237-246 (1995).
4. Xue, L. Y., Qiu, Y., He, J., Kung, H. J. & Oleinick, N. L. Etk/Bmx, a PH-domain containing tyrosine kinase, protects prostate cancer cells from apoptosis induced by photodynamic therapy or thapsigargin. *Oncogene* 18, 3391-3398 (1999).
5. Tsai, Y. T. et al. Etk, a Btk family tyrosine kinase, mediates cellular transformation by linking Src to STAT3 activation. *Mol. Cell. Biol.* 20, 2043-2054 (2000).
6. Gibson, T. J., Hyvonen, M., Musacchio, A., Saraste, M. & Birney, E. PH domain: the first anniversary. *Trends Biochem. Sci.* 19, 349-353 (1994).
7. Yao, L. et al. Pleckstrin homology domains interact with filamentous actin. *J. Biol. Chem.* 274, 19752-19761 (1999).
8. Parsons, J. T. Integrin-mediated signalling: regulation by protein tyrosine kinases and small GTP-binding proteins. *Curr. Opin. Cell Biol.* 8, 146-152 (1996).
9. Giancotti, F. G. & Ruoslahti, E. Integrin signalling. *Science* 285, 1028-1032 (1999).
10. Chishti, A. H. et al. The FERM domain: a unique module involved in the linkage of cytoplasmic proteins to the membrane. *Trends Biochem. Sci.* 23, 281-282 (1998).
11. Girault, J. A., Labesse, G., Mornon, J. P. & Callebaut, L. The N-termini of FAK and JAKs contain divergent band 4.1 domains. *Trends Biochem. Sci.* 24, 54-57 (1999).
12. Sieg, D. J. et al. FAK integrates growth-factor and integrin signals to promote cell migration. *Nature Cell Biol.* 2, 249-256 (2000).
13. Stephenson, R. A. et al. Metastatic model for human prostate cancer using orthotopic implantation in nude mice. *J. Natl Cancer Inst.* 84, 951-957 (1992).
14. Thompson, E. W. et al. Association of increased basement membrane invasiveness with absence of estrogen receptor and expression of vimentin in human breast cancer cell lines. *J. Cell. Physiol.* 150, 534-544 (1992).
15. Pearson, M. A., Reczek, D., Bretscher, A. & Karplus, P. A. Structure of the ERM protein moesin reveals the FERM domain fold masked by an extended actin binding tail domain. *Cell* 101, 259-270 (2000).
16. Reiske, H. R. et al. Requirement of phosphatidylinositol 3-kinase in focal adhesion kinase-promoted cell migration. *J. Biol. Chem.* 274, 12361-12366 (1999).
17. Ilic, D. et al. Reduced cell motility and enhanced focal adhesion contact formation in cells from FAK-deficient mice. *Nature* 377, 539-544 (1995).
18. Cary, L. A., Han, D. C., Polte, T. R., Hanks, S. K. & Guan, J. L. Identification of p130Cas as a mediator of focal adhesion kinase-promoted cell migration. *J. Cell Biol.* 140, 211-221 (1998).
19. Jiang, Y. et al. The G protein Gα12 stimulates Bruton's tyrosine kinase and a rasGAP through a conserved PH/BM domain. *Nature* 395, 808-813 (1998).
20. Johannes, F. I. et al. Bruton's tyrosine kinase (Btk) associates with protein kinase C mu. *FEBS Lett* 461, 68-72 (1999).
21. Li, T. et al. Activation of Bruton's tyrosine kinase (BTK) by a point mutation in its pleckstrin homology (PH) domain. *Immunity* 2, 451-60 (1995).
22. Hyvonen, M. & Saraste, M. Structure of the PH domain and Btk motif from Bruton's tyrosine kinase: molecular explanations for X-linked agammaglobulinemia. *EMBO J.* 16, 3396-3404 (1997).
23. Sieg, D. J. et al. *Pyk2* and Src-family protein-tyrosine kinases compensate for the loss of FAK in fibronectin-stimulated signaling events but *Pyk2* does not fully function to enhance FAK-cell migration. *EMBO J.* 17, 5933-5947 (1998).
24. Rawlings, D. J. et al. Activation of BTK by a phosphorylation mechanism initiated by SRC family kinases. *Science* 271, 822-825 (1996).
25. Andreotti, A. H., Bunnell, S. C., Feng, S., Berg, L. J. & Schreiber, S. L. Regulatory intramolecular association in a tyrosine kinase of the Tec family. *Nature* 385, 93-97 (1997).
26. Cary, L. A., Chang, J. F. & Guan, J. L. Stimulation of cell migration by overexpression of focal adhesion kinase and its association with Src and Fyn. *J. Cell Sci.* 109, 1787-1794 (1996).
27. Chen, H. C., Appeddu, P. A., Isoda, H. & Guan, J. L. Phosphorylation of tyrosine 397 in focal adhesion kinase is required for binding phosphatidylinositol 3-kinase. *J. Biol. Chem.* 271, 26329-26334 (1996).
28. Zheng, C. et al. Differential regulation of *Pyk2* and focal adhesion kinase (FAK). The C-terminal domain of FAK confers response to cell adhesion. *J. Biol. Chem.* 273, 2384-2389 (1998).

**ACKNOWLEDGEMENTS**

We thank L. Higgins for mass spectrometry data analysis, J. McCarthy and J. Iida for providing reagents and advice throughout the study, D. Ilic and C. Damsky for providing FAK-null cells, and D. Schläpfer, J. DeLarco and X. Zhang for helpful discussion. This work was supported by grants from Minnesota Medical Foundation, AHA (9960296Z) and NIH (CA83380) to Y.Q. Correspondence and requests for materials should be addressed to Y.Q.

# A novel function for the Tec family tyrosine kinase Itk in activation of $\beta 1$ integrins by the T-cell receptor

Melody L. Woods<sup>1,2,3</sup>, Wendy J. Kivens<sup>1,2,3</sup>,  
Margaret A. Adelsman<sup>1,2,3</sup>, Yun Qiu<sup>1,3</sup>,  
Avery August<sup>4</sup> and Yoji Shimizu<sup>1,2,3,5</sup>

<sup>1</sup>Department of Laboratory Medicine and Pathology, <sup>2</sup>Center for Immunology and <sup>3</sup>Cancer Center, University of Minnesota Medical School, Minneapolis, MN 55455 and <sup>4</sup>Immunology Research Laboratories, Department of Veterinary Science, The Pennsylvania State University, University Park, PA 16802, USA

<sup>5</sup>Corresponding author  
e-mail: shimi002@tc.umn.edu

**Stimulation of T cells via the CD3–T-cell receptor (TCR) complex results in rapid increases in  $\beta 1$  integrin-mediated adhesion via poorly defined intracellular signaling events. We demonstrate that TCR-mediated activation of  $\beta 1$  integrins requires activation of the Tec family tyrosine kinase Itk and phosphatidylinositol 3-kinase (PI 3-K)-dependent recruitment of Itk to detergent-insoluble glyco-sphingolipid-enriched microdomains (DIGs) via binding of the pleckstrin homology domain of Itk to the PI 3-K product PI(3,4,5)-P<sub>3</sub>. Activation of PI 3-K and the src family kinase Lck, via stimulation of the CD4 co-receptor, can initiate  $\beta 1$  integrin activation that is dependent on Itk function. Targeting of Itk specifically to DIGs, coupled with CD4 stimulation, can also activate  $\beta 1$  integrin function independently of TCR stimulation. Changes in  $\beta 1$  integrin function mediated by TCR activation of Itk are also accompanied by Itk-dependent modulation of the actin cytoskeleton. Thus, TCR-mediated activation of  $\beta 1$  integrins involves membrane relocalization and activation of Itk via coordinate action of PI 3-K and a src family tyrosine kinase.**

**Keywords:** integrin/Itk/Lck/phosphatidylinositol 3-kinase/  
T lymphocyte

## Introduction

Efficient recognition of foreign pathogens by the immune system requires the systemic trafficking of a pool of potentially antigen-reactive T lymphocytes through secondary lymphoid organs and peripheral tissue sites. Integrin adhesion receptors mediate critical interactions of T cells with other cells and extracellular matrix components during trafficking, as well as during antigen-specific recognition events in tissue (Shimizu *et al.*, 1999). Consequently, the functional activity of integrin receptors on T cells is dynamically regulated by external cues provided by other cell surface receptors. Stimulation of the antigen-specific CD3–T-cell receptor (TCR) complex results in increased T-cell adhesion mediated by  $\beta 1$  or  $\beta 2$  integrins that does not require an increase in overall

levels of integrins on the cell surface (Dustin and Springer, 1989; van Kooyk *et al.*, 1989; Shimizu *et al.*, 1990). This change in T-cell adhesion upon antigen receptor stimulation occurs within minutes of stimulation and represents one of the earliest functional responses of T lymphocytes to activation.

Stimulation of the CD3–TCR complex initiates a complex array of intracellular signaling events, beginning with src family tyrosine kinase-mediated phosphorylation of cytoplasmic immunoreceptor tyrosine-based activation motifs and recruitment of the Syk family tyrosine kinase ZAP-70 to the CD3–TCR complex (Kane *et al.*, 2000). Activated ZAP-70 subsequently phosphorylates substrates such as the adapter proteins LAT and SLP-76, resulting in the formation of protein–protein signaling complexes that initiate downstream signaling events, such as phospholipase C- $\gamma 1$  (PLC- $\gamma 1$ ) activation and subsequent production of inositol 1,4,5-trisphosphate (IP<sub>3</sub>) and diacylglycerol. Recent studies have highlighted the importance of the nucleation of these signaling complexes in specialized microdomains at the T-cell plasma membrane, where critical signaling molecules, such as src family kinases and LAT, are preferentially localized due to acylation or palmitoylation (Xavier *et al.*, 1998; Zhang *et al.*, 1998; Janes *et al.*, 1999; Lin *et al.*, 1999; Langlet *et al.*, 2000). Although the importance of these signaling cascades to CD3–TCR-mediated transcriptional activation of cytokine genes such as interleukin-2 is well established, the signaling pathways by which the CD3–TCR complex regulates integrin-mediated T-cell adhesion are less clear. Studies with ZAP-70-deficient T cells have demonstrated an essential role for ZAP-70 in CD3–TCR-mediated increases in  $\beta 1$  integrin function (Epler *et al.*, 2000). Phorbol ester stimulation can also enhance integrin function (Dustin and Springer, 1989; van Kooyk *et al.*, 1989; Shimizu *et al.*, 1990), and protein kinase C inhibitors can partially block CD3–TCR-mediated activation of  $\beta 1$  and  $\beta 2$  integrins (Dustin and Springer, 1989; van Kooyk *et al.*, 1989; Mobley *et al.*, 1994). Integrin function can also be modulated by activation of various GTPases, including H-ras, R-ras and Rap1 (Zhang *et al.*, 1996; Hughes *et al.*, 1997; A.M.O'Rourke *et al.*, 1998; Caron *et al.*, 2000; Katagiri *et al.*, 2000; Reedquist *et al.*, 2000). However, while GTPase activation is often sufficient to activate integrins, the role that these GTPases play in the signaling pathways by which CD3–TCR and other receptors regulate integrin activity is less clearly established. Modulation of the actin cytoskeleton is likely to play a key role in activation-dependent integrin regulation, as integrin-dependent cell adhesion is sensitive to cytochalasin D, and CD3–TCR stimulation can induce  $\beta 2$  integrin clustering (Stewart *et al.*, 1996). While activation-dependent changes in  $\beta 1$  integrin affinity, as assessed by soluble ligand binding

and induction of integrin activation epitopes, have been observed following CD3-TCR stimulation, T-cell adhesion to fibronectin (FN) is not inhibited by excess soluble ligand (Woods *et al.*, 2000).

Several recent studies have demonstrated a critical role for the lipid kinase phosphatidylinositol 3-kinase (PI 3-K) in the regulation of integrin activity by CD3-TCR as well as other PI 3-K-coupled cell surface receptors (Shimizu and Hunt, 1996; Zell *et al.*, 1996; Chan *et al.*, 1997; Kivens *et al.*, 1998; Nagel *et al.*, 1998; Kinashi *et al.*, 1999; Woods *et al.*, 2000). However, the identification of molecules downstream of PI 3-K that regulate integrin functional activity has remained elusive. Although the  $\beta 2$  integrin-binding protein cytohesin-1 has been proposed to regulate lymphocyte function-associated antigen-1 (LFA-1) function downstream of PI 3-K (Nagel *et al.*, 1998), cytohesin-1 does not bind to the  $\beta 1$  integrin cytoplasmic domain or regulate its functional activity (Kolanus *et al.*, 1996).

PI 3-K activation results in the generation of D-3-phosphorylated lipid products at the cell membrane, which results in membrane recruitment of proteins containing pleckstrin homology (PH) domains via PH domain binding to the PI 3-K-generated lipid products (Klarlund *et al.*, 1997; Lemmon *et al.*, 1997). We reasoned that CD3-TCR-mediated regulation of  $\beta 1$  integrins may involve PI 3-K-dependent recruitment of an effector with such a PH domain. Members of the Tec family of tyrosine kinases represent potential candidate effectors (Schaeffer and Schwartzberg, 2000). The Tec tyrosine kinase Itk (also Emt or Tsk) is regulated in a PI 3-K-dependent manner and has been implicated in phosphorylation of PLC- $\gamma 1$ , calcium flux and mitogen-activated protein (MAP) kinase activation (Liu *et al.*, 1998; Perez-Villar and Kanner, 1999; Schaeffer *et al.*, 1999). Itk plays a role in T-cell development (Liao and Littman, 1995) and mutations in the PH domain of the Tec family kinase Btk can result in B-cell immunodeficiency (Sideras and Smith, 1995). In this report, we identify a novel function for Itk in the regulation of  $\beta 1$  integrin function by CD3-TCR in a manner that is dependent on coordinate upstream activation of src family kinases, PI 3-K, and the specific recruitment of Itk to detergent-insoluble membrane microdomains.

## Results

### CD3-TCR stimulation results in PI 3-K-dependent changes in the intracellular localization of Itk in T cells

Recent studies have highlighted the critical role of recruitment to and assembly of protein-protein complexes in detergent-insoluble glycosphingolipid-enriched membrane microdomains (DIGs) for efficient T-cell activation (Moran and Miceli, 1998; Xavier *et al.*, 1998; Xavier and Seed, 1999). We examined the potential role of PI 3-K in the CD3-TCR-dependent recruitment of Itk to DIGs (Xavier *et al.*, 1998). Cytosolic and membrane fractions and DIGs were prepared from unstimulated and CD3-stimulated Jurkat T cells. Western blotting was utilized to examine the presence of Itk in these fractions (Figure 1A). While a basal level of Itk could be found in both cytosolic and membrane fractions, CD3 stimulation resulted in

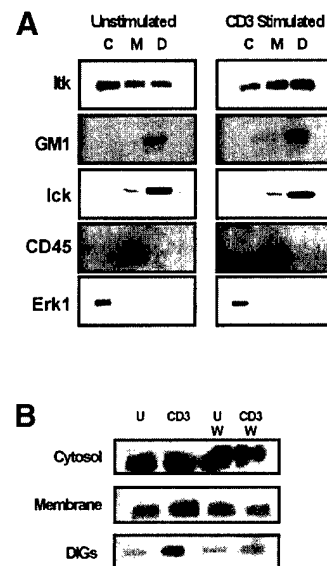
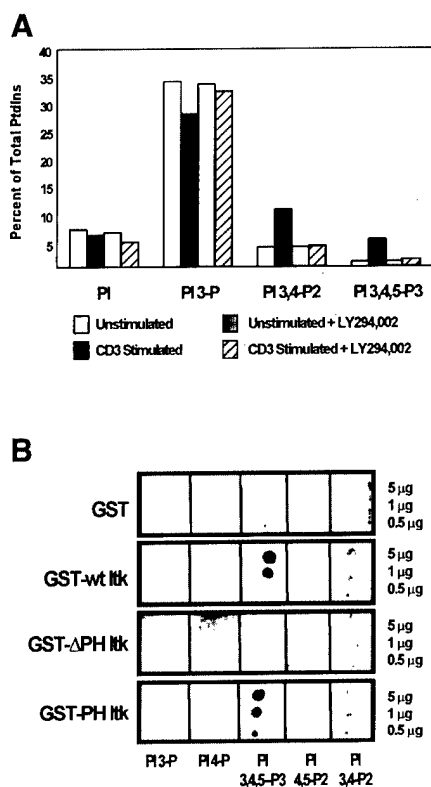

**Fig. 1.** CD3-TCR stimulation results in PI 3-K-dependent increases in Itk localization in DIGs. (A) Jurkat T cells were left unstimulated (left panel) or were CD3 stimulated (right panel) for 5 min at 37°C. Cytosolic (C), membrane (M) and DIG (D) preparations containing  $2 \times 10^6$  cell equivalents from cytosolic fractions or  $6 \times 10^6$  cell equivalents from the membrane or DIG fractions were separated by SDS-PAGE, transferred to PVDF membranes, and immunoblotted for Itk, Lck, CD45 and Erk1 using specific antibodies. The presence of the GM1 ganglioside was detected with cholera toxin B subunit as described in Materials and methods. (B) Jurkat T cells were either left unstimulated (U) or CD3 stimulated (CD3) as in (A) in the presence or absence of 100 nM wortmannin (W). Cytosolic, membrane and DIG preparations were prepared as in (A) and analyzed for the presence of Itk. Results are representative of a minimum of three different experiments performed with fractions prepared on separate days.

increased levels of Itk in T-cell membrane fractions. More significantly, CD3 stimulation of Jurkat T cells resulted in increased localization of Itk in DIGs (Figure 1A). The src family kinase p56<sup>lck</sup> (Lck), which can phosphorylate Itk and thereby regulate Itk kinase activity (August *et al.*, 1997; Heyeck *et al.*, 1997), was also enriched in DIGs, although CD3 stimulation did not appreciably increase Lck localization in DIGs when compared with unstimulated T cells. The cytoplasmic kinase extracellular regulated kinase (ERK1), the CD45 cell surface receptor and the GM1 glycosphingolipid were used as markers to verify the integrity of our cytosolic, membrane and DIG preparations, respectively (Figure 1A). In the presence of the PI 3-K inhibitors wortmannin or LY294,002, CD3-induced increases in the localization of Itk to both the membrane and DIGs were dramatically inhibited (Figure 1B and data not shown). Thus, CD3 stimulation results in PI 3-K-dependent recruitment of Itk to DIGs, where it co-localizes with Lck.

### The PH domain of Itk binds to PI(3,4,5)-P<sub>3</sub> and mediates CD3-dependent relocalization of Itk

We measured phospholipid production in unstimulated and CD3-stimulated T cells by activating permeabilized Jurkat T cells in the presence of [<sup>32</sup>P]ATP, followed by the analysis of labeled phospholipids by TLC. CD3 stimulation of T cells resulted in an increase in the relative amounts of both PI(3,4)-P<sub>2</sub> and PI(3,4,5)-P<sub>3</sub>; this increase



**Fig. 2.** The PH domain of Itk mediates binding of Itk to the PI 3-K product PI(3,4,5)-P<sub>3</sub>. **(A)** [<sup>32</sup>P]ATP-labeled Jurkat cells were left unstimulated (open and shaded bars) or were CD3 stimulated (solid and hatched bars) for 10 min at 37°C in the presence (shaded and hatched bars) or absence (open and solid bars) of 50 μM LY294,002. Phospholipids were extracted and analyzed as described in Materials and methods. Incorporation of <sup>32</sup>P into specific phosphatidylinositols was quantitated on a phosphoimager. Relative levels of PI, PI(3)-P, PI(3,4)-P<sub>2</sub> and PI(3,4,5)-P<sub>3</sub> were determined by dividing the volume intensity (as determined by the phosphoimager) of each individual phospholipid spot by the total volume intensity of all phospholipid spots and multiplying by 100. Results shown are from one representative experiment out of a minimum of three separate experiments. **(B)** The binding of GST, GST-wild-type (wt) Itk, GST-PH Itk and GST-ΔPH Itk fusion proteins to different amounts of PI(3)-P, PI(4)-P, PI(4,5)-P<sub>2</sub>, PI(3,4)-P<sub>2</sub> and PI(3,4,5)-P<sub>3</sub> immobilized on nitrocellulose membranes was determined by FAT western blotting as described in Materials and methods. Following immunoblotting, membranes were exposed to iodine to verify that comparable amounts of each lipid were immobilized on the membranes (data not shown).

in D-3-phosphorylated lipids was inhibited by the PI 3-K inhibitors LY294,002 and wortmannin (Figure 2A and data not shown). Our results using this approach are consistent with previous studies of PI production in Jurkat T cells (Ward *et al.*, 1992). Since both PI(3,4)-P<sub>2</sub> and PI(3,4,5)-P<sub>3</sub> can bind to specific PH domains, we analyzed the ability of a glutathione *S*-transferase (GST) fusion protein expressing Itk to bind to various amounts of purified phospholipids immobilized on a nitrocellulose membrane (Stevenson *et al.*, 1998). Nitrocellulose membranes spotted with phospholipids were incubated with GST-Itk fusion proteins and binding of the fusion protein was detected by an anti-GST antibody and enhanced chemiluminescence (ECL). The GST-wild-type (wt) Itk fusion protein bound in a dose-dependent manner specifically to PI(3,4,5)-P<sub>3</sub> (Figure 2B). No binding was

detectable to PI(3)-P, PI(4)-P or PI(4,5)-P<sub>2</sub>, and only very low binding between GST-wt Itk and PI(3,4)-P<sub>2</sub> was observed (Figure 2B). All lipids were bound on the membrane at comparable levels, as detected by iodine visualization of the lipids following blotting (data not shown). Binding of Itk to PI(3,4,5)-P<sub>3</sub> was mediated by the PH domain of Itk, since: (i) binding to PI(3,4,5)-P<sub>3</sub> was lost when the PH domain of Itk was deleted in the GST-Itk fusion protein (GST-ΔPH Itk); and (ii) a GST fusion protein expressing only the PH domain of Itk (GST-PH Itk) exhibited binding to PI(3,4,5)-P<sub>3</sub> similar to GST-Itk (Figure 2B).

To determine the role of the Itk PH domain in CD3-mediated relocalization of Itk, unstimulated and CD3-stimulated Jurkat T cells that were transiently transfected with green fluorescent protein (GFP)-tagged Itk constructs (Figure 3) were examined by confocal microscopy. Representative images of cells expressing varying levels of GFP are shown in Figure 4A. In unstimulated Jurkat T cells, GFP-wt Itk was found in both the cytoplasm and at the membrane. CD3 stimulation led to increased punctate distribution of GFP-wt Itk specifically at the membrane. In contrast, Jurkat T cells expressing the GFP-ΔPH Itk fusion protein exhibited cytoplasmic GFP expression, with little membrane localization. Furthermore, CD3 stimulation did not lead to any changes in this pattern of expression. In cells expressing the GFP-PH Itk fusion protein, predominant membrane localization of this fusion protein was observed, even in unstimulated Jurkat T cells. CD3 stimulation of these cells resulted in accentuated punctate GFP expression at the membrane. Similar results were observed when assessing the intracellular localization of endogenous Itk in unstimulated Jurkat T cells (Figure 4B). CD3 stimulation of Jurkat T cells led to membrane localization of endogenous Itk and co-localization of endogenous Itk with DIGs, which were detected in these confocal microscopy experiments with fluorescein isothiocyanate (FITC)-conjugated cholera toxin B subunit (Figure 4B).

Similar to endogenous Itk, CD3 stimulation resulted in increased localization of the GFP-Itk fusion protein in membrane fractions and DIGs of Jurkat T cells (Figure 4C). Low levels of GFP-wt Itk were observed in DIGs of unstimulated transfectants with overexposure of the blot shown in Figure 4C (data not shown). In contrast, the GFP-ΔPH Itk fusion protein was found exclusively in the cytosolic fraction in both unstimulated and CD3-stimulated T cells, providing further evidence that the PH domain of Itk is critical for membrane localization of Itk.

We also determined the tyrosine phosphorylation status of endogenous Itk and GFP-Itk constructs localized to DIGs in unstimulated and CD3-stimulated Jurkat T cells (Figure 4D). Sorted Jurkat T cells expressing GFP only, GFP-wt Itk, GFP-kinase-inactive Itk (GFP-KN Itk) or the GFP-PH Itk fusion protein were CD3 stimulated and Itk was immunoprecipitated from DIGs and analyzed by western blotting. While unstimulated Jurkat T cells exhibited minimal tyrosine phosphorylation of Itk found in DIGs, CD3 stimulation resulted in tyrosine phosphorylation of endogenous Itk, as well as increased localization of Itk in DIGs (Figure 4D). CD3 stimulation also resulted in tyrosine phosphorylation of the GFP-wt Itk construct. In contrast, expression of GFP-KN Itk or the GFP-PH Itk

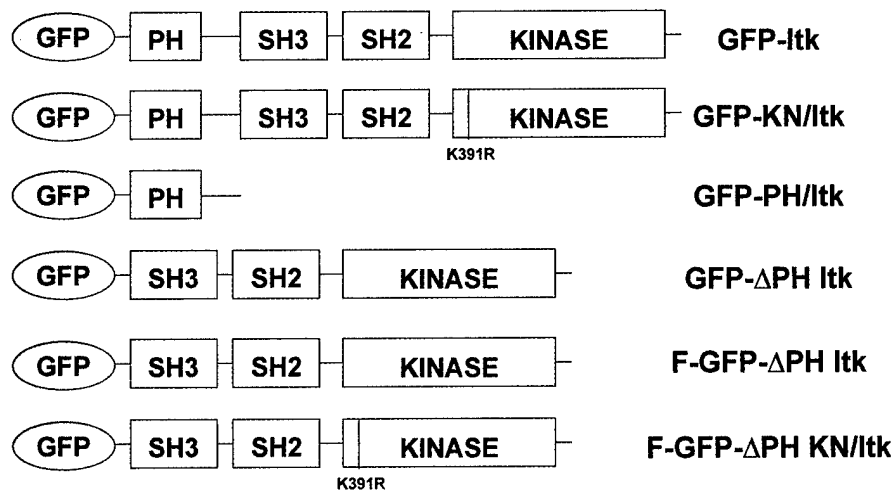

Fig. 3. Diagram of GFP-Itk fusion protein constructs utilized in this study.

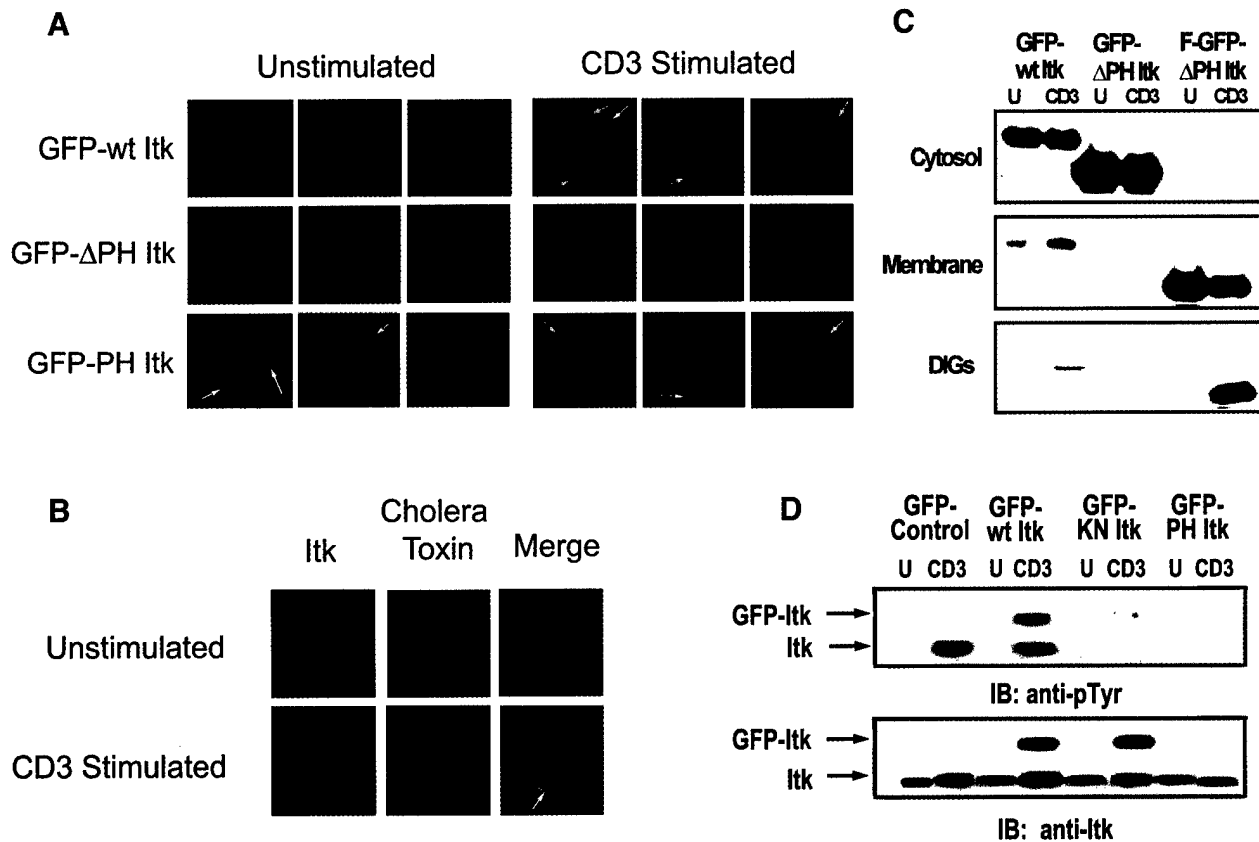

Fig. 4. The PH domain of Itk is required for Itk membrane redistribution upon CD3 stimulation of human T cells. (A) Jurkat T cells transiently transfected with GFP-wt Itk, GFP- $\Delta$ PH Itk and GFP-PH Itk were left unstimulated or CD3 stimulated for 10 min at 37°C. The cells were then visualized by confocal microscopy. Arrows highlight areas of punctate membrane localization of Itk. A minimum of 100 cells for each transfected/stimulation condition were examined and three representative cells for each construct and stimulation condition are shown. (B) Jurkat T cells were left unstimulated or CD3 stimulated for 10 min at 37°C. Cells were stained with anti-Itk, biotin-conjugated rabbit anti-goat IgG and streptavidin-APC, followed by staining with FITC-conjugated cholera toxin B subunit. Representative cell images are shown, and a merged image demonstrating colocalization of endogenous Itk in DIGs following CD3 stimulation (in yellow) is shown. (C) Jurkat cells transiently transfected with GFP-wt Itk, GFP- $\Delta$ PH Itk or F-GFP- $\Delta$ PH Itk were left unstimulated (U) or CD3 stimulated (CD3) for 5 min at 37°C. Cytosolic, membrane and DIG fractions were prepared as in Figure 1. Anti-HA immunoprecipitations were performed with lysates containing  $5 \times 10^6$  GFP<sup>+</sup> cell equivalents. Immunoprecipitates were separated on a 7.5% SDS-polyacrylamide gel, transferred to PVDF and immunoblotted with an anti-HA antibody. (D) Jurkat cells transiently transfected with GFP-control, GFP-wt Itk, GFP-KN Itk or GFP-PH Itk were sorted and left unstimulated (U) or CD3 stimulated (CD3) for 5 min at 37°C. DIG fractions were prepared as in Figure 1. Anti-Itk immunoprecipitations were performed with lysates containing  $3 \times 10^6$  cells. Immunoprecipitates were separated on a 7.5% SDS-polyacrylamide gel, transferred to PVDF and immunoblotted with an anti-phosphotyrosine mAb, stripped and reprobbed with an anti-Itk antibody.

fusion protein inhibited CD3-induced tyrosine phosphorylation of endogenous Itk in DIGs and CD3-induced increases in localization of endogenous Itk to DIGs (Figure 4D).

#### **CD3-induced activation of $\beta 1$ integrin-mediated T-cell adhesion to FN requires the kinase activity of Itk**

Since CD3 stimulation of T cells results in increased  $\beta 1$  integrin functional activity that is sensitive to PI 3-K inhibition (Woods *et al.*, 2000), we explored a potential role for Itk in this functional response of T cells. Jurkat T cells were transiently transfected with constructs expressing either GFP or various GFP-Itk fusion proteins (Figure 3). GFP expression was obtained in ~20–35% of the total number of cells recovered (data not shown). Following adhesion of this heterogeneous population of transfectants to FN under various stimulation conditions, the adherent cells were collected and quantitated by flow cytometric analysis (Kivens and Shimizu, 1998; Kivens *et al.*, 1998). Post-acquisition gating was used to quantitate the percentage adhesion of the GFP-negative and -positive subpopulations in each sample. In all of the transfectants analyzed, CD3 stimulation or stimulation with the phorbol ester phorbol 12-myristate 13-acetate (PMA) for 10 min at 37°C resulted in enhanced adhesion to FN of the GFP-negative cells (Figure 5). Adhesion of unstimulated and stimulated transfectants expressing GFP or the GFP-Itk fusion protein was comparable to that of GFP-negative cells in the same sample. In contrast, transfectants expressing a GFP fusion protein expressing the kinase-inactive form of Itk (GFP-KN/Itk) exhibited impaired adhesion to FN following CD3 stimulation (Figure 5). This defect in CD3-induced activation of  $\beta 1$  integrins was not due to global defects in  $\beta 1$  integrin function, since transfectants expressing kinase-inactive Itk still exhibited increased adhesion to FN following PMA stimulation. Furthermore, CD3-induced increases in T-cell adhesion to FN were not inhibited by expression of a GFP fusion protein expressing a kinase-inactive form of the related Tec family tyrosine kinase Etk (GFP-KN/Etk) (Figure 5), even though Etk is expressed in Jurkat T cells (data not shown). These results demonstrate a specific role for Itk tyrosine kinase activity in CD3-mediated regulation of  $\beta 1$  integrin function.

#### **CD3-induced regulation of $\beta 1$ integrin function involves membrane localization of Itk**

Similar to the result obtained with cells expressing the kinase-inactive GFP-Itk fusion protein, expression of the GFP fusion protein expressing just the PH domain of Itk also resulted in specific inhibition of CD3-induced adhesion to FN (Figure 5). This effect on adhesion was specific to the PH domain of Itk, as expression of a GFP fusion protein expressing the PH domain of Etk did not inhibit either PMA- or CD3-induced adhesion to FN (Figure 5). This suggests a critical role for PH domain-dependent membrane localization of Itk in CD3-TCR regulation of  $\beta 1$  integrin function. To determine whether membrane targeting of Itk was sufficient to induce increased  $\beta 1$  integrin function, we created a GFP fusion protein containing a membrane-targeting farnesylation sequence (F-GFP) and Itk lacking the PH domain (F-GFP- $\Delta$ PH Itk). Western blotting analysis of cell fractions demonstrated

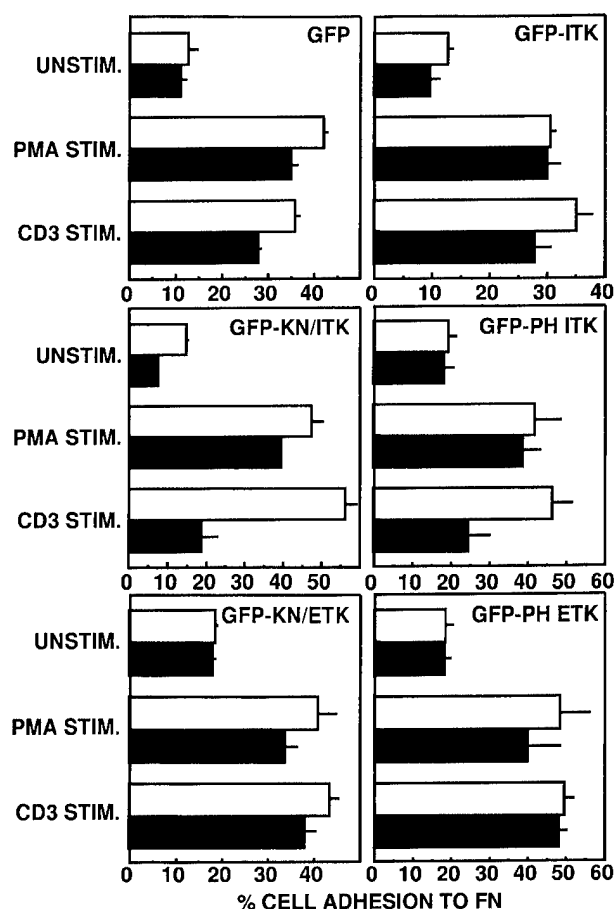

**Fig. 5.** Expression of kinase-inactive Itk or the PH domain of Itk inhibits CD3-mediated increases in  $\beta 1$  integrin-mediated T-cell adhesion to FN. Adhesion of transiently transfected Jurkat cells expressing either GFP, GFP-Itk, GFP-KN/Itk, GFP-PH Itk, GFP-KN/Etk or GFP-PH Etk to FN following no stimulation (UNSTIM.) or after stimulation with PMA (PMA STIM.) or CD3 stimulation (CD3 STIM.) for 10 min at 37°C was assessed. Adhesion was quantitated by flow cytometry and the results indicate the percentage adhesion of GFP-negative cells (open bars) and GFP-positive cells (closed bars) under each stimulation condition with each transfected population. Results shown are from one of three independent replicate experiments.

that the F-GFP- $\Delta$ PH Itk fusion protein was constitutively localized to the T-cell membrane, even in unstimulated T cells (Figure 4C). In addition, CD3 stimulation dramatically increased localization of F-GFP- $\Delta$ PH Itk to DIGs (Figure 4C). In adhesion experiments, expression of either F-GFP or F-GFP- $\Delta$ PH Itk did not enhance the adhesion of unstimulated, PMA- or CD3-stimulated Jurkat T cells (Figure 6 and data not shown), suggesting that membrane targeting of Itk in the absence of additional stimulation is not sufficient to induce increased  $\beta 1$  integrin function. However, stimulation of the CD4 co-receptor, which activates Lck (Turner *et al.*, 1990; Baldari *et al.*, 1995), resulted in enhanced adhesion of transfectants expressing F-GFP- $\Delta$ PH Itk but not F-GFP. Itk kinase activity in the membrane-targeted Itk construct was critical for this response, since CD4 stimulation of Jurkat T cells expressing F-GFP- $\Delta$ PH Itk containing the kinase-inactive mutation K391R did not result in enhanced adhesion to FN (Figure 6). Increased adhesion induced by CD4 stimulation and membrane-targeted Itk was inhibited by the anti- $\beta 1$  integrin antibody AIIB2 (data not shown).

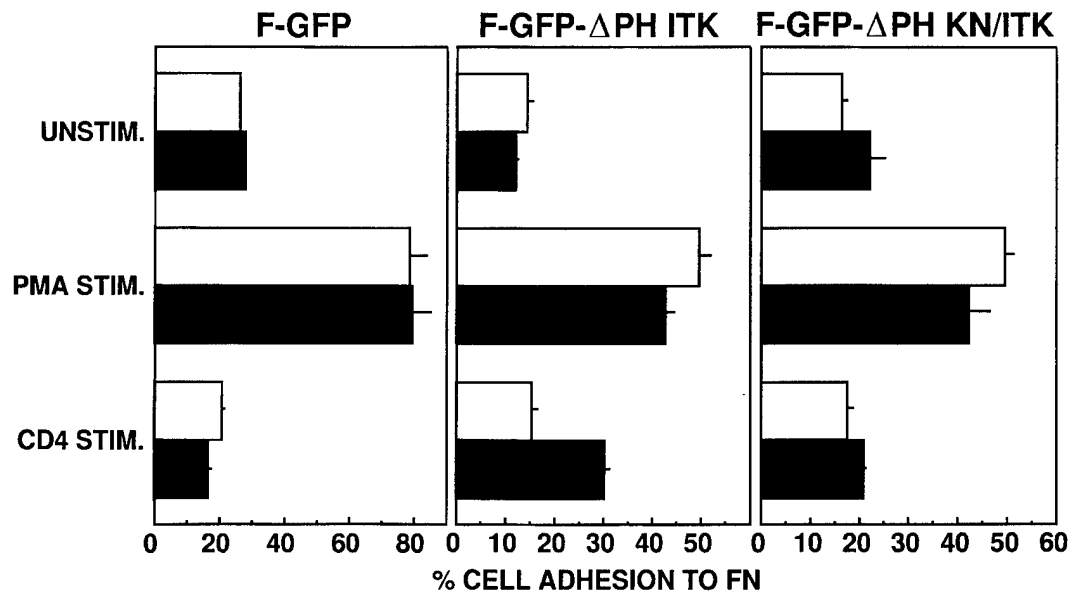

**Fig. 6.** Membrane-targeted Itk requires an additional activation signal provided by CD4 co-receptor stimulation in order to activate  $\beta 1$  integrins. Jurkat cells were transiently transfected with the farnesylated GFP expression vectors encoding F-GFP, F-GFP- $\Delta$ PH Itk or F-GFP- $\Delta$ PH KN/Itk and analyzed for adhesion as in Figure 5 following no stimulation (UNSTIM.) or stimulation for 10 min at 37°C with PMA (PMA STIM.) or a CD4-specific antibody (CD4 STIM.). Adhesion was quantitated by flow cytometry and the results indicate the percentage adhesion of GFP-negative cells (open bars) and GFP-positive cells (closed bars) under each stimulation condition with each transfected population. Results shown are from one of three independent replicate experiments.

These results suggest that Itk-dependent regulation of  $\beta 1$  integrin function requires Lck activation and membrane targeting of Itk.

#### **Increased $\beta 1$ integrin function mediated by PI 3-K and Lck is dependent on Itk**

Since our results suggest that PI 3-K-dependent membrane localization of Itk is critical to CD3-mediated activation of  $\beta 1$  integrins, we tested whether expression of a constitutively active catalytic subunit of PI 3-K (ACT.p110) would be sufficient to induce  $\beta 1$  integrin activation. Similar to the results obtained with F-GFP- $\Delta$ PH Itk, expression of active PI 3-K in the absence of additional signals was insufficient to enhance basal adhesion of Jurkat T cells to FN (Figure 7A). However, expression of active PI 3-K together with CD4 cross-linking led to increased adhesion similar to that observed with PMA stimulation (Figure 7A). Increased T-cell adhesion induced by active PI 3-K and CD4 stimulation was dependent on Itk kinase activity, since adhesion was inhibited by kinase-inactive GFP-Itk, but not by wild-type GFP-Itk (Figure 7A).

The effect of CD4 stimulation on T-cell adhesion in the presence of active PI 3-K requires Lck, as CD4 stimulation of Lck-deficient J.CaM1 cells expressing active PI 3-K did not result in enhanced adhesion to FN (Figure 7B). However, adhesion was enhanced following CD4 stimulation of stable Lck<sup>+</sup> J.CaM1 transfectants (Denny *et al.*, 2000) expressing active PI 3-K. In addition, CD3-induced adhesion was defective in J.CaM1 cells but not in Lck<sup>+</sup> J.CaM1 transfectants (Figure 7B), illustrating a critical role for Lck in CD3-mediated increases in T-cell adhesion to FN. Flow cytometric analysis revealed comparable levels of expression of CD3,  $\alpha 4\beta 1$  integrin and  $\alpha 5\beta 1$  integrin on wild-type Jurkat T cells and J.CaM1

cells. However, CD4 expression was slightly lower on J.CaM1 cells (data not shown).

#### **Kinase-inactive Itk inhibits CD3-induced $\beta 1$ integrin activation in PTEN<sup>+</sup> peripheral human T cells**

Levels of PI(3,4,5)-P<sub>3</sub> in the T-cell plasma membrane are regulated not only by PI 3-K, which produces PI(3,4,5)-P<sub>3</sub> when active, but also by phosphatases that dephosphorylate PI(3,4,5)-P<sub>3</sub>. One such phosphatase is the dual specificity phosphatase PTEN (phosphatase and tensin homolog deleted on chromosome 10) (Di Cristofano and Pandolfi, 2000). Recent studies indicate that PTEN expression is impaired in Jurkat T cells (Shan *et al.*, 2000; Wang *et al.*, 2000), resulting in elevated basal levels of membrane-associated Itk in this cell line when compared with PTEN<sup>+</sup> peripheral T cells (Shan *et al.*, 2000). Thus, we also assessed the role of Itk in  $\beta 1$  integrin regulation in phytohemagglutinin (PHA)-stimulated human T-cell blasts, which we have previously shown exhibit CD3-inducible increases in adhesion to FN via  $\beta 1$  integrins (Epler *et al.*, 2000). Western blotting analysis indicated that human T-cell blasts express PTEN (Figure 8A). Consistent with previous studies (Shan *et al.*, 2000; Wang *et al.*, 2000), minimal levels of PTEN were detected in Jurkat T-cell lysates (Figure 8A). Localization of Itk to DIGs upon CD3 stimulation of human T-cell blasts was also assessed (Figure 8B). In contrast to Jurkat T cells, there was less Itk found in DIGs isolated from unstimulated T-cell blasts (Figure 8B). However, similar to the results observed with Jurkat T cells, CD3 stimulation resulted in a wortmannin-sensitive increase in Itk localized to DIGs in human T-cell blasts (Figure 8B). In adhesion assays, basal adhesion of human T-cell blasts to FN was slightly lower than that observed with Jurkat T cells. However,

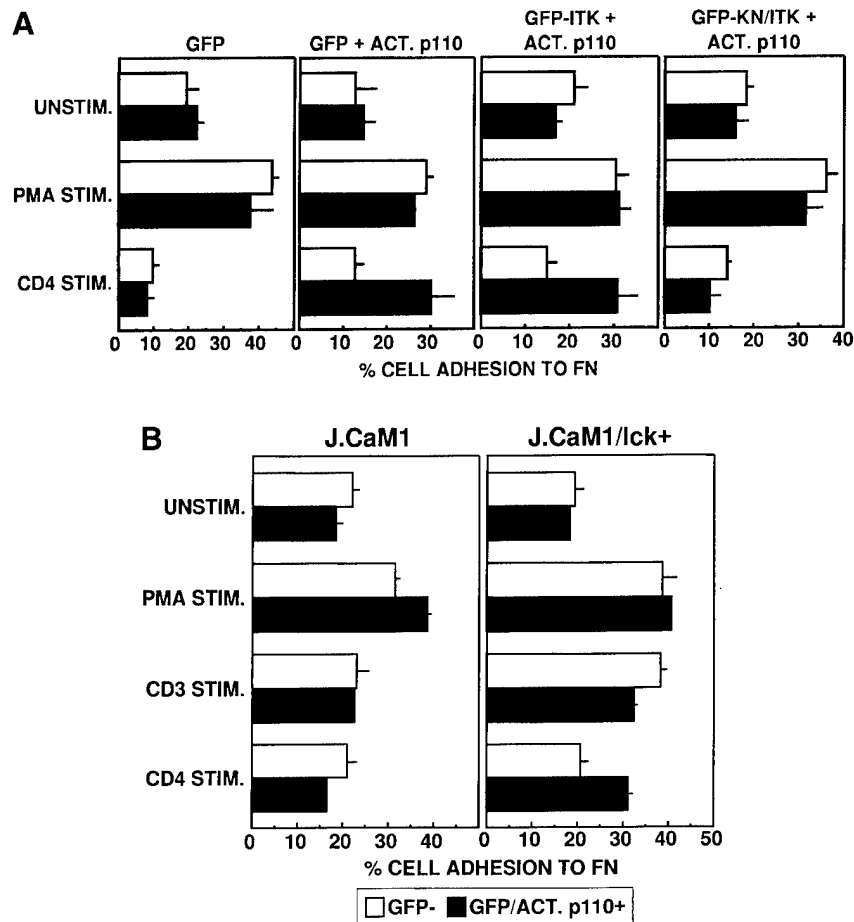

**Fig. 7.** Enhanced basal  $\beta 1$  integrin-mediated adhesion of human T cells induced by activation of PI 3-K and Lck can be inhibited by kinase-inactive Itk. **(A)** Jurkat T cells were transiently transfected with vectors encoding either GFP, GFP plus constitutively active PI 3-K (ACT.p110), GFP-Itk plus ACT.p110, or GFP-KN/Itk plus ACT.p110, and analyzed for adhesion as in Figure 5 following no stimulation (UNSTIM.) or stimulation for 10 min at 37°C with PMA (PMA STIM.) or the CD4-specific antibody OKT4 (CD4 STIM.). Adhesion was quantitated by flow cytometry and the results indicate the percentage adhesion of GFP-negative cells (open bars) and GFP-positive cells (closed bars) under each stimulation condition with each transfected population. Results shown are from one of three independent replicate experiments. **(B)** J.CaM1 cells and stable transfectants of J.CaM1 expressing Lck (J.CaM1/lck<sup>+</sup>) were transiently transfected with vectors encoding GFP plus constitutively active PI 3-K (ACT.p110), and analyzed for adhesion as in Figure 5 following no stimulation (UNSTIM.) or stimulation for 10 min at 37°C with PMA (PMA STIM.), the CD3-specific antibody OKT3 (CD3 STIM.) or the CD4-specific antibody OKT4 (CD4 STIM.). Adhesion was quantitated by flow cytometry and the results indicate the percentage adhesion of GFP-negative cells (open bars) and GFP-positive cells (closed bars) under each stimulation condition with each transfected population. Results shown are from one of three independent replicate experiments.

expression of GFP-KN/Itk, but not GFP-Itk or GFP, also inhibited CD3-mediated enhancement of the adhesion of human T-cell blasts to FN (Figure 8C). Kinase-inactive Itk did not affect PMA-induced adhesion of human T-cell blasts to FN.

#### ***Itk regulates CD3-induced actin polymerization***

Regulation of integrin function can be controlled by changes in the actin cytoskeleton. Since Tec family tyrosine kinases associate with proteins implicated in cytoskeletal reorganization (Bunnell *et al.*, 1996), we explored a role for Itk in regulating the T-cell actin cytoskeleton. Jurkat T cells transiently expressing GFP or GFP-Itk fusion proteins were sorted, stimulated with anti-CD3 antibody and then stained with biotin-labeled phalloidin and streptavidin-phycoerythrin (PE). CD3 stimulation of Jurkat T cells expressing either GFP or GFP-Itk resulted in a 5- to 6-fold increase in actin

polymerization (Figure 9). In contrast, CD3 stimulation of Jurkat T cells expressing GFP-KN/Itk or GFP-PH Itk resulted in only a 2.5-fold increase in actin polymerization. Thus, these results suggest that Itk plays an important role in regulating changes in the actin cytoskeleton upon CD3 stimulation that are critical to integrin function.

#### **Discussion**

The results in this study demonstrate a novel function for the Tec family tyrosine kinase Itk in the regulation of  $\beta 1$  integrin-mediated adhesion by the CD3-TCR complex that is dependent on activation of both PI 3-K and the src kinase Lck. We propose that coordination of signaling between these kinases is critical for activation-dependent redistribution of Itk to an appropriate compartment in the T-cell membrane, where it becomes accessible to Lck, a kinase that regulates Itk tyrosine kinase activity (August

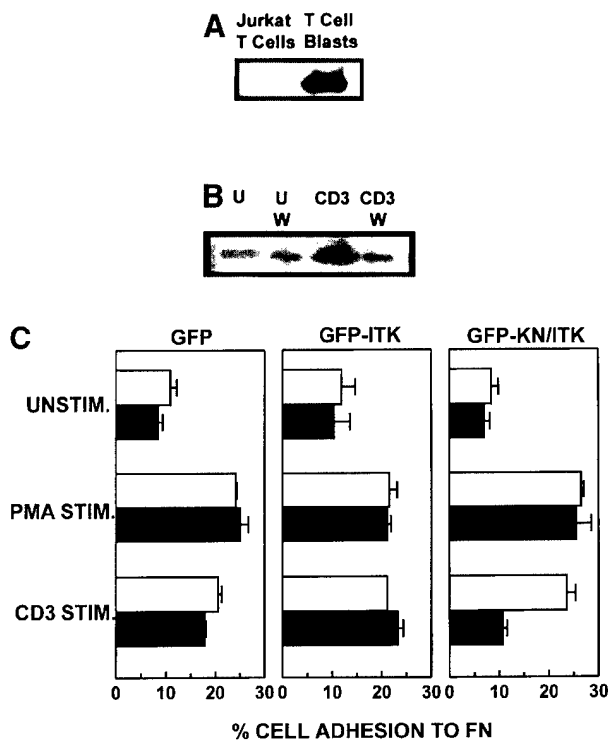

**Fig. 8.** Kinase-inactive Itk inhibits CD3-mediated activation of  $\beta 1$  integrins expressed on peripheral human T-cell blasts. PHA-stimulated human T-cell blasts were prepared as described in Materials and methods. (A) Whole-cell lysates from Jurkat T cells ( $3 \times 10^6$  cell equivalents) and human T-cell blasts ( $3 \times 10^6$  cell equivalents) were separated by SDS-PAGE, transferred to PVDF membranes and immunoblotted for PTEN with an anti-PTEN polyclonal antibody. (B) DIGs were prepared from unstimulated (U) and CD3-stimulated (CD3) human T-cell blasts ( $5 \times 10^6$  cell equivalents) in the presence or absence of 100 nM wortmannin (W) and immunoblotted for the presence of Itk as in Figure 1. (C) Adhesion of transiently transfected human T-cell blasts expressing either GFP, GFP-Itk or GFP-KN/Itk to FN following no stimulation (UNSTIM.) or after stimulation with PMA (PMA STIM.) or CD3 (CD3 STIM.) for 10 min at 37°C was assessed as in Figure 5. Adhesion was quantitated by flow cytometry and the results indicate the percentage adhesion of GFP-negative cells (open bars) and GFP-positive cells (closed bars) under each stimulation condition with each transfected population. Results shown are from one of three independent replicate experiments using human T-cell blasts isolated from different donors.

*et al.*, 1997; Heyeck *et al.*, 1997). Previous studies have demonstrated a critical role for PI 3-K in the regulation of  $\beta 1$  integrin function by CD3-TCR (Woods *et al.*, 2000) as well as several other cell surface receptors (Shimizu and Hunt, 1996; Zell *et al.*, 1996; Chan *et al.*, 1997; Kivens *et al.*, 1998; Kinashi *et al.*, 1999). Several lines of evidence argue that a prominent function of PI 3-K in integrin regulation is membrane recruitment of Itk mediated via binding of the PH domain of Itk to PI(3,4,5)-P<sub>3</sub> produced upon PI 3-K activation by CD3-TCR: (i) CD3-mediated increases in membrane recruitment of Itk are blocked by PI 3-K inhibitors or by deletion of the PH domain of Itk; (ii) Itk binding to PI(3,4,5)-P<sub>3</sub> is dependent on the Itk PH domain; (iii) the PH domain of Itk is sufficient to bind PI(3,4,5)-P<sub>3</sub> and to inhibit CD3-induced increases in  $\beta 1$  integrin function; and (iv) constitutive membrane targeting of Itk with a farnesylation sequence can

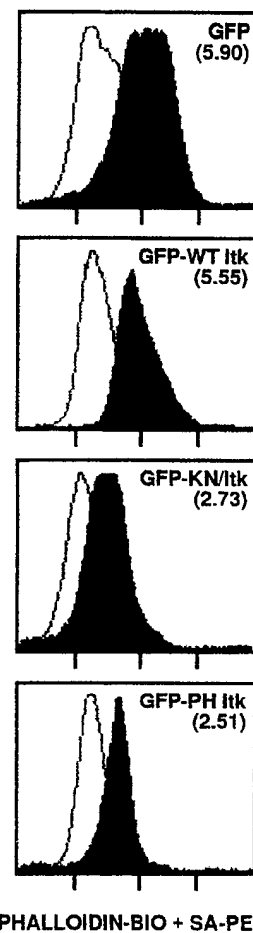

**Fig. 9.** CD3-induced actin polymerization is dependent on Itk. Jurkat T cells transiently transfected with vectors encoding either GFP, GFP-Itk (GFP-WT Itk), GFP-KN/Itk or GFP-PH Itk were sorted to isolate a homogeneous population of GFP<sup>+</sup> T cells, and then left unstimulated (open curves) or CD3-stimulated for 10 min at 37°C (closed curves). Cells were stained with biotin-labeled phalloidin and PE-conjugated streptavidin, and analyzed by flow cytometry. Numbers in parentheses in each set of curves indicate the fold increase in mean fluorescence intensity of phalloidin staining upon CD3 stimulation.

synergize with CD4 stimulation, which activates Lck, to enhance  $\beta 1$  integrin-mediated adhesion in the absence of CD3-TCR stimulation. Our results are consistent with previous studies in COS cells indicating a role for PI 3-K in membrane recruitment of Itk (August *et al.*, 1997; Heyeck *et al.*, 1997), although CD3-dependent membrane recruitment of Itk via PI 3-K in Jurkat T cells has not been consistently observed in earlier reports (Lu *et al.*, 1998; Ching *et al.*, 1999; Shan and Wange, 1999; Bunnell *et al.*, 2000). The functional significance of the PH domain of Itk in CD3-dependent regulation of  $\beta 1$  integrin function further highlights the critical role that lipid binding to PH domains of Tec family tyrosine kinases plays in Tec family kinase function, as first vividly illustrated by the analysis of PH domain mutations in Btk that result in B-cell immunodeficiency (Sideras and Smith, 1995). Although the Tec family tyrosine kinase Etk is also expressed in Jurkat T cells (data not shown), expression of kinase-inactive Etk or the Etk PH domain did not inhibit CD3-induced increases in T-cell adhesion to FN. This

suggests a specific role for Itk in regulating  $\beta 1$  integrin function in T cells.

The src family tyrosine kinase Lck is one of several molecules that are preferentially localized in DIGs (Xavier *et al.*, 1998; Ilangumaran *et al.*, 1999; Langlet *et al.*, 2000), specialized regions of the plasma membrane that provide an important scaffold for the assembly of functional signaling complexes. CD3-TCR stimulation results in enhanced localization of several signaling molecules in DIGs, including ZAP-70 (Xavier *et al.*, 1998; Salojin *et al.*, 2000), LAT (Zhang *et al.*, 1998; Lin *et al.*, 1999), the p85 subunit of PI 3-K (Xavier *et al.*, 1998) and now Itk. CD3-dependent recruitment of Itk to DIGs places Itk in proximity to Lck, which has been shown to enhance Itk tyrosine kinase activity via tyrosine phosphorylation of Itk (Gibson *et al.*, 1996; August *et al.*, 1997; Heyeck *et al.*, 1997). Indeed, we observed that CD3 stimulation induced dramatic increases in tyrosine phosphorylation of DIG-localized Itk. In addition, expression of kinase-inactive Itk or the PH domain of Itk specifically inhibited CD3-induced tyrosine phosphorylation of endogenous Itk found in DIGs, as well as CD3-mediated increases in Itk found in DIGs. Thus, PI 3-K functions specifically to promote the co-localization of Itk with its upstream regulatory tyrosine kinase. Such redistribution of key signaling molecules into and out of DIGs following CD3-TCR stimulation represents a powerful mode of regulating signal transduction via careful assembly of kinases with molecules that regulate their enzymatic activity.

Although previous studies have suggested a role for src family kinases in regulating both PI 3-K and Itk in COS cells (August *et al.*, 1997), our results suggest that Lck and PI 3-K play distinct and complementary roles in CD3-TCR regulation of  $\beta 1$  integrin-mediated adhesion. Stimulation of the CD4 co-receptor, which efficiently activates Lck (Turner *et al.*, 1990; Baldari *et al.*, 1995), by itself was insufficient to induce increases in  $\beta 1$  integrin functional activity. CD4 signaling resulted in increased  $\beta 1$  integrin functional activity only in the presence of constitutively active PI 3-K or membrane-targeted Itk. Analysis of Lck-deficient Jurkat T cells illustrated that the ability of CD4 signaling to enhance  $\beta 1$  integrin functional activity in conjunction with active PI 3-K was dependent on Lck expression. Thus, these results support the model that PI 3-K serves to play a critical role in targeting of Itk to DIGs, while Lck plays a role in regulating Itk once it has been recruited to DIGs.

The inability of CD3 stimulation to enhance  $\beta 1$  integrin-mediated adhesion of Lck-deficient JCaM1 T cells indicates that Lck is required for  $\beta 1$  integrin activation by CD3-TCR. In addition to its proposed role in regulating Itk tyrosine kinase activity (August *et al.*, 1997), Lck probably also plays a central role in regulating  $\beta 1$  integrin function via its central role in recruiting and regulating ZAP-70 tyrosine kinase activity (Iwashima *et al.*, 1994; Chan *et al.*, 1995). Recent studies using peripheral T cells and ZAP-70-deficient Jurkat T cells indicate that  $\beta 1$  integrin activation induced by CD3-TCR stimulation requires ZAP-70 tyrosine kinase activity (Epler *et al.*, 2000). ZAP-70, like Lck, may participate in CD3-TCR-mediated activation of  $\beta 1$  integrins via regulation of Itk, since activation of Itk is dependent on ZAP-70 function in Jurkat T cells (Shan and Wange, 1999). The exact role of

ZAP-70 in regulating Itk activity is currently unclear, although ZAP-70 cannot phosphorylate the Itk kinase domain directly (Shan and Wange, 1999). One possibility that must be considered is that ZAP-70 might regulate PI 3-K-dependent localization of Itk to DIGs, since the Syk tyrosine kinase regulates PI 3-K activity in B cells (Beitz *et al.*, 1999; Pogue *et al.*, 2000). However, the reported lack of effect of loss of ZAP-70 expression on CD3-dependent localization of Itk to DIGs (Shan and Wange, 1999) is inconsistent with this hypothesis. Unlike our results, this prior study did not observe significant relocalization of Itk to DIGs upon CD3 stimulation of wild-type Jurkat T cells. The reasons for this discrepancy are unclear, but may relate to differences in the cell lines employed, such as the use of specific Jurkat T-cell subclones or Jurkat T cells expressing SV40 large T antigen. Since CD3 stimulation also results in the association of Itk with the ZAP-70 substrate LAT (linker for activation of T cells) (Ching *et al.*, 2000), ZAP-70 might serve to participate in Itk-dependent regulation of  $\beta 1$  integrin function via effects on Itk-LAT association.

The membrane localization of the Tec family tyrosine kinase Btk is also regulated by PI 3-K (Salim *et al.*, 1996; Li *et al.*, 1997). Although Btk is not found at appreciable levels in resting B cells, there is basal membrane and DIG localization of Itk in unstimulated Jurkat T cells. Recent studies have demonstrated that this basal membrane localization of Itk is due to lack of expression in Jurkat T cells of the PTEN phosphatase, which dephosphorylates the PI 3-K lipid product PI(3,4,5)-P<sub>3</sub> (Shan *et al.*, 2000). However, our analysis of PTEN<sup>+</sup> human T-cell blasts and PTEN<sup>-</sup> Jurkat T cells indicated that CD3 stimulation of both cell types induced wortmannin-sensitive increases in the localization of Itk to DIGs. Furthermore, Itk found in DIGs in unstimulated Jurkat T cells was not appreciably tyrosine phosphorylated. In addition, we observed that expression of kinase-inactive Itk was equally effective in inhibiting CD3-dependent increases in  $\beta 1$  integrin function in PTEN<sup>-</sup> Jurkat T cells and in PTEN<sup>+</sup> human peripheral T-cell blasts. These results suggest that PTEN levels may regulate basal levels of Itk at the T-cell membrane, but that CD3 stimulation can still enhance Itk membrane localization and Itk kinase activity. In prior studies, we have noted that unstimulated Jurkat T cells generally exhibit higher levels of basal  $\beta 1$  integrin-mediated adhesion than unstimulated peripheral T cells (Mobley *et al.*, 1994). It is possible that PTEN might regulate basal  $\beta 1$  integrin functional activity by regulating the constitutive amount of D-3-phosphorylated lipids found at the membrane of unstimulated T cells. We have been unable to test directly the function of PTEN in  $\beta 1$  integrin function, since expression of PTEN in our Jurkat T-cell line results in death of the transient transfectants (data not shown), similar to what has been observed by other groups (Wang *et al.*, 2000).

Changes in  $\beta 1$  integrin conformation that result in enhanced ligand binding affinity have been proposed as one mechanism by which activation increases  $\beta 1$  integrin-mediated adhesion (Bazzoni and Hemler, 1998). However, CD3 stimulation of Jurkat T cells does not lead to enhanced binding of soluble FN or increased expression of antibody epitopes used as markers for  $\beta 1$  integrins with increased affinity (Woods *et al.*, 2000). Alternatively,

changes in the cytoskeleton have been proposed to regulate integrin microclustering, thereby altering the avidity of integrin-mediated adhesion (Kucik *et al.*, 1996; van Kooyk *et al.*, 1999; Calderwood *et al.*, 2000). The ability of kinase-inactive Itk and the Itk PH domain to inhibit CD3-induced increases in actin polymerization suggests that Itk regulates  $\beta 1$  integrin functional activity via regulation of the T-cell actin cytoskeleton. The association of Itk with cytoskeletal regulatory proteins, such as WASP (Bunnell *et al.*, 1996), and a proposed role for Btk in regulating Rho-family GTPase activity in B cells, are consistent with this hypothesis (Nore *et al.*, 2000). Since stimulation of the CD28 co-receptor also activates  $\beta 1$  integrin function (Zell *et al.*, 1996) as well as Itk tyrosine kinase activity (August *et al.*, 1994), Itk may play a similar role in regulating  $\beta 1$  integrin function by other cell surface receptors in addition to the T-cell receptor.

In summary, we have defined a novel function for the Tec family tyrosine kinase Itk in regulating  $\beta 1$  integrin functional activity induced by CD3-TCR stimulation. Itk-dependent regulation of  $\beta 1$  integrin functional activity involves PI 3-K-dependent localization of Itk to DIGs and Lck-dependent regulation of Itk kinase activity. It will be important in future studies to determine how other signaling proteins found in DIGs might participate in the regulation of  $\beta 1$  integrin function, how Itk impacts on T-cell cytoskeletal reorganization, and whether other Tec family tyrosine kinases serve a similar regulatory function.

## Materials and methods

### Antibodies and reagents

The CD3-specific monoclonal antibody (mAb) OKT3 and the CD4-specific mAb OKT4 were purchased from the American Type Culture Collection (ATCC; Manassas, VA). The anti-Itk, anti-Lck, anti-Erk1 and anti-CD45 antibodies were purchased from Santa Cruz Biotechnology Inc. (Santa Cruz, CA). The anti-hemagglutinin (HA) antibody 3F10 was purchased from Boehringer-Mannheim (Indianapolis, IN) and the anti-HA mAb 16B12 was purchased from BabCo (Berkeley, CA). The anti-PTEN polyclonal antibody was purchased from Upstate Biotechnology (Lake Placid, NY). The inhibitory anti- $\beta 1$  integrin mAb AIIB2 was obtained from the Developmental Studies Hybridoma Bank (Iowa City, IA). FN was provided by Dr J.McCarthy (University of Minnesota, Minneapolis, MN). Horseradish peroxidase (HRP)-, FITC- and biotin-conjugated forms of cholera toxin B subunit were purchased from Sigma Chemical Co. (St Louis, MO). Stock solutions of wortmannin (Sigma), LY294,002 (Alexis Corporation, San Diego, CA) and PMA (LC Services Corp., Woburn, MA) were dissolved in dimethyl sulfoxide (DMSO) and stored at  $-70^{\circ}\text{C}$ .

### Cell culture and stimulation conditions

The JE64-6A Jurkat T-cell line (Mobley *et al.*, 1994) is a subclone of the Jurkat E6-1 cell line available from the ATCC (Manassas, VA). The Lck-deficient J.CaM1 cell line was also obtained from the ATCC. Both cell lines were maintained in RPMI 1640 medium supplemented with 10% fetal calf serum (FCS) (Atlanta Biologicals, Norcross, GA), L-glutamine and penicillin/streptomycin. The Lck<sup>+</sup> stable transfectant of J.CaM1 was kindly provided by Dr David Straus (University of Chicago, Chicago, IL) and was cultured as previously described (Denny *et al.*, 2000). Human peripheral blood T-cell blasts were prepared by stimulating human peripheral blood lymphocytes with PHA for 4 days as previously described (Epler *et al.*, 2000). For CD3-TCR stimulation, T cells were incubated on ice with the anti-CD3 mAb OKT3 at 1  $\mu\text{g}/\text{ml}$  per  $10^6$  cells. The cells were washed  $3\times$  in ice-cold phosphate-buffered saline (PBS), and incubated for 30 min on ice with goat anti-mouse IgG at 0.5  $\mu\text{g}/\text{ml}$  per  $10^6$  cells. For the confocal microscopy experiments in Figure 4B, rat anti-mouse IgG was used at 0.5  $\mu\text{g}/\text{ml}$  per  $10^6$  cells. The cells were then rapidly warmed to  $37^{\circ}\text{C}$  for the indicated period of time.

### Cellular fractionation

Cellular fractionation was adapted from previously described methods for isolating cytosolic, membrane and DIG fractions (Xavier *et al.*, 1998). Briefly,  $50 \times 10^6$  Jurkat cells or  $100 \times 10^6$  PHA T-cell blasts were resuspended in 1 ml of hypotonic buffer [10 mM Tris pH 8.0, 1 mM  $\text{MgCl}_2$ , 1 mM  $\text{NaOVO}_4$ , 1 mM phenylmethylsulfonyl fluoride (PMSF), 1  $\mu\text{g}/\text{ml}$  aprotinin, 1  $\mu\text{g}/\text{ml}$  leupeptin] and sonicated for 1 min. Thirty microliters of 5 M NaCl were added and the lysate was spun down at 200 g for 10 min. The supernatant containing cytosolic and membrane proteins was collected and 3 ml of isotonic buffer (0.6 M NaCl, 1 mM  $\text{NaOVO}_4$ , 1 mM PMSF, 1  $\mu\text{g}/\text{ml}$  aprotinin, 1  $\mu\text{g}/\text{ml}$  leupeptin) were added. The lysate was then spun at 100 000 g for 45 min. The supernatant containing cytosolic proteins was collected and 0.3 ml of cytosolic adjusting buffer (1% Triton, 1% SDS, 1% sodium deoxycholate, 1 mM  $\text{NaOVO}_4$ , 1 mM PMSF, 1  $\mu\text{g}/\text{ml}$  aprotinin, 1  $\mu\text{g}/\text{ml}$  leupeptin) were added. The pellet containing membrane and DIG proteins was resuspended in 1 ml of MBS (25 mM MES, 150 mM NaCl pH 6.5, 2 mM EDTA, 0.5% Triton X-100, 1 mM  $\text{NaOVO}_4$ , 1 mM PMSF, 1  $\mu\text{g}/\text{ml}$  aprotinin, 1  $\mu\text{g}/\text{ml}$  leupeptin) and sonicated for 1 min. The lysates were then gently mixed with 1 ml of 80% sucrose in MBS, which was then overlaid with 35% sucrose in MBS and 5% sucrose in MBS. The sucrose gradient was spun at 200 000 g for 16 h at  $4^{\circ}\text{C}$ . DIG-associated proteins were collected from the 5/35% interphase. Membrane proteins were collected from the bottom 1 ml of the sucrose gradient. For anti-PTEN immunoblotting, Jurkat T cells and human T-cell blasts were lysed in lysis buffer (1% Triton X-100, 1% sodium deoxycholate, 158 mM NaCl, 10 mM Tris-HCl, 5 mM EDTA, 2 mM sodium vanadate, 20  $\mu\text{g}/\text{ml}$  leupeptin, 20  $\mu\text{g}/\text{ml}$  aprotinin, 2 mM PMSF) as previously described (Epler *et al.*, 2000).

### Western blotting

Western blotting was performed as previously described (Hunter and Shimizu, 1997). The anti-Itk, anti-Lck, anti-ERK1, anti-CD45 and anti-PTEN antibodies were used at a 1:500 dilution in PBS/5% milk. Cholera toxin B subunit-HRP was used at a 1:200 dilution in PBS/5% milk. Secondary reagents were HRP-conjugated donkey anti-goat IgG (Jackson ImmunoResearch Laboratories, Inc., West Grove, PA), donkey anti-rabbit IgG (Amersham Pharmacia Biotech, Inc., Piscataway, NJ), goat anti-mouse IgG (Caltag Inc., South San Francisco, CA) and rat anti-mouse IgG (Jackson). Membranes were developed using ECL (Pierce, Rockford, IL).

### Plasmid constructs

The HA-tagged wild-type Itk and  $\Delta\text{PH}$  Itk cDNA clones were inserted into the *XhoI-EcoRI* sites of the pEGFP-C3 vector (Clontech, Palo Alto, CA) and into the *BamHI-EcoRI* sites of the pGEX-4T-1 GST fusion protein vector (Amersham Pharmacia Biotech). The kinase-inactive (K391R) Itk construct was first subcloned into the pMEXNeo vector, which added an in-frame HA tag at the 5' end, and then directionally cloned into the GFP and GST vectors as described above. Each plasmid was sequenced to confirm that the inserts were inserted into the appropriate reading frame. The stop codon of the pEGFP-F vector coding for farnesylated GFP (Clontech) was mutated to an alanine and then the HA- $\Delta\text{PH}$  Itk cDNA was inserted in-frame at the 3' end of the eGFP coding sequence. The kinase-inactive K391R mutation was created using standard site-directed mutagenesis techniques (Stratagene). The GFP-Itk fusion protein constructs used in this study are shown in Figure 3. The Itk cDNA clones (Qiu *et al.*, 1998) were subcloned into the *KpnI-ApaI* site of the pEGFP-C1 fusion protein vector (Clontech). The constitutively active PI 3-K p110 cDNA (ACT.p110) was purchased from Upstate Biotechnology (Lake Placid, NY).

### Transient transfections

Transient transfections were performed as previously described using a BTX square wave electroporator (BTX, San Diego, CA) set at 240 V with a pulse length of 25 ms (Romzek *et al.*, 1998). After electroporation, cells were incubated for 10 min at room temperature before resuspension at  $1 \times 10^6$  cells/ml in RPMI 1640 medium supplemented with 10% FCS, L-glutamine and penicillin/streptomycin. Cells were harvested after 14–18 h for use in western blotting or in adhesion assays.

### Itk and GFP fusion protein immunoblotting

Cells were transiently transfected as described above. The total number of GFP<sup>+</sup> cells was determined by flow cytometry for western blotting with anti-HA. In the anti-phosphotyrosine experiment shown in Figure 4D, transfected cells were sorted by flow cytometry to obtain a homogeneous population of GFP<sup>+</sup> cells using a Becton Dickinson FACSVantage. Equal

numbers of GFP<sup>+</sup> cells from each transfectant were either unstimulated or CD3-stimulated as described above. Cytosolic fractions, membrane fractions and DIGs were prepared as described above. Immunoprecipitations were performed using anti-HA (3F10)-coated protein A-Sepharose beads or anti-Itk-coated protein G beads as previously described (Hunter and Shimizu, 1997). The samples were separated on a 7.5% SDS-PAGE mini-gel, transferred to PVDF, and immunoblotted with anti-HA mAb (16B12) or anti-pTyr (4G10) followed by HRP-conjugated goat anti-mouse IgG. Detection was by ECL.

#### Confocal microscopy

Jurkat T cells, either untransfected or transiently transfected with GFP-Itk constructs, were left unstimulated or CD3 stimulated, and then fixed in 4% paraformaldehyde for 30 min at room temperature. The GFP-Itk-transfected cells were added to poly-L-lysine-coated slides and allowed to settle. Untransfected cells were washed in 1× Perm Buffer [PBS containing 0.5% saponin (Sigma), 2% FCS and 0.2% sodium azide] followed by a 1× wash in Superperm Buffer (3 parts Perm Buffer + 1 part FCS). The cells were incubated in Perm buffer containing anti-Itk at 2 µg/10<sup>6</sup> cells for 30 min at room temperature. Following a 2× wash in Perm Buffer, the cells were incubated for an additional 30 min at room temperature with biotin-labeled rabbit anti-goat IgG (Southern Biotechnology, Birmingham, AL) in Perm Buffer. The cells were subsequently stained for 30 min with Streptavidin-APC (BD Pharmingen, San Diego, CA) in Perm Buffer. The cells were then added to poly-L-lysine-coated slides and allowed to settle. After the untransfected cells had settled, the slides were blocked with 2% FCS in PBS, then stained with FITC-conjugated cholera toxin B subunit at 8 µg/ml for 30 min. Slides were analyzed on a Bio-Rad MRC 1024 confocal microscope.

#### Phospholipid extraction

Jurkat cells were stimulated in the presence or absence of 50 µM LY294,002 with the anti-CD3 mAb OKT3 and goat anti-mouse IgG for 10 min at 37°C as described above in the presence of 100 µM ATP, 10 µCi <sup>32</sup>P-ATP, 12% TransPort reagent (Life Technologies, Gaithersburg, MD). The cells were first incubated on ice for 60 min then rapidly warmed to 37°C for 5 min. Lipids were extracted, spotted onto TLC plates with the lipid standards PI, PI(4)-P, PI(4,5)-P<sub>2</sub> (Sigma), PI(3)-P, PI(3,4)-P<sub>2</sub> and PI(3,4,5)-P<sub>3</sub> (Matreya, Inc., Street Pleasant Gap, PA) and developed as previously described (L.M.O'Rourke et al., 1998). The <sup>32</sup>P incorporated into the phosphatidylinositols was quantitated on a phosphoimager. The percentage of individual phosphoinositides was determined by dividing the volume (intensity as determined by the phosphoimager) of each individual spot by the total volume (intensity of all phospholipid spots as determined by the phosphoimager) and multiplying by 100. Extracted lipids and lipid standards were developed in an iodine tank and compared.

#### FAT western blotting

Binding of GST-Itk fusion proteins to purified phospholipids was performed as previously described (Stevenson et al., 1998). Briefly, PI(3)-P, PI(4)-P, PI(4,5)-P<sub>2</sub>, PI(3,4)-P<sub>2</sub> and PI(3,4,5)-P<sub>3</sub> were spotted onto nitrocellulose membranes and dried. The membrane was blocked with 3% fatty acid-free bovine serum albumin, then GST, GST-wt Itk, GST-PH Itk and GST-APH Itk fusion proteins were incubated with the membrane. Binding of the GST fusion proteins was detected by chemiluminescence following incubation with goat anti-GST mAb conjugated to HRP. Lipids were developed in an iodine tank and compared to ensure equal loading.

#### Adhesion assays

The adhesion of transiently transfected T cells to FN (0.3 µg/well) was analyzed as previously described (Kivens and Shimizu, 1998; Kivens et al., 1998). For PMA stimulation, T cells were added to wells containing 10 ng/ml PMA. For CD3 and CD4 stimulation, cells pre-coated with OKT3 mAb (anti-CD3) or OKT4 mAb (anti-CD4) were added to wells containing 1 µg/ml goat anti-mouse IgG. Plates were then rapidly warmed to 37°C for 10 min and washed to remove non-adherent cells. An aliquot of each cell sample representing the same volume used in each well for the adhesion assay was prepared for flow cytometric analysis for verification of the cell numbers added per well. Adherent cells were removed with PBS/0.1% EDTA and collected. Cells from six replicate wells were pooled into a tube, pelleted and resuspended in 200 µl of PBS/5% FCS supplemented with 50 µl of PKH26 reference microbeads (Sigma) and 25 µl of propidium iodide (Sigma). Each sample was then analyzed on a Becton-Dickinson FACScan as previously described (Kivens and Shimizu, 1998; Kivens et al., 1998). For each sample

analyzed, the total number of reference microbeads acquired was divided by the bead density to obtain the total volume of sample acquired. Post-acquisition gating was used to define GFP-negative and -positive subpopulations. Within these two subpopulations, the total number of T cells in each sample was then determined by the following equation: [(T cells acquired)/(ml of sample acquired)](0.275 ml). Initial numbers of T cells added to each well at the start of the adhesion assay were calculated by the same procedure using the pre-adherent cell samples.

#### Actin polymerization

Jurkat T cells were transfected with GFP-Itk constructs and sorted to 95% purity as described above. Sorted cells were left unstimulated or stimulated by mAb cross-linking of CD3, then fixed in 4% paraformaldehyde containing 1 mg/ml lysophosphatidylcholine (Sigma) for 15 min at room temperature. Following fixation, biotin-XX-phalloidin (Molecular Probes, Eugene, OR) was added at 1 µM and the cells were incubated for 15 min at 37°C. Cells were then stained with streptavidin-PE (Southern Biotechnology Associates) at 1 µg/10<sup>6</sup> cells for 20 min at room temperature. Cells were analyzed on a Becton-Dickinson FACScan.

#### Acknowledgements

We thank Dr D.Straus for providing critical reagents and helpful comments, and J.Peller of the University of Minnesota Cancer Center Flow Cytometry Core Facility for technical assistance with cell sorting. This work was supported by NIH grant AI31126 (Y.S.) and by NIH postdoctoral fellowship grants AI09993 (M.L.W.) and AR09438 (W.J.K.). Y.S. is the Harry Kay Chair of Cancer Research at the University of Minnesota.

#### References

- August, A., Gibson, S., Kawakami, Y., Kawakami, T., Mills, G.B. and Dupont, B. (1994) CD28 is associated with and induces the immediate tyrosine phosphorylation and activation of the Tec family kinase ITK/EMT in the human Jurkat leukemic T-cell line. *Proc. Natl Acad. Sci. USA*, **91**, 9347-9351.
- August, A., Sadra, A., Dupont, B. and Hanafusa, H. (1997) Src-induced activation of inducible T cell kinase (ITK) requires phosphatidylinositol 3-kinase activity and the pleckstrin homology domain of inducible T cell kinase. *Proc. Natl Acad. Sci. USA*, **94**, 11227-11232.
- Baldari, C.T., Milia, E., Di Somma, M.M., Baldoni, F., Valitutti, S. and Telford, J.L. (1995) Distinct signaling properties identify functionally different CD4 epitopes. *Eur. J. Immunol.*, **25**, 1843-1850.
- Bazzoni, G. and Hemler, M.E. (1998) Are changes in integrin affinity and conformation overemphasized. *Trends Biochem. Sci.*, **23**, 30-34.
- Beitz, L.O., Fruman, D.A., Kurosaki, T., Cantley, L.C. and Scharenberg, A.M. (1999) SYK is upstream of phosphoinositide 3-kinase in B cell receptor signaling. *J. Biol. Chem.*, **274**, 32662-32666.
- Bunnell, S.C., Henry, P.A., Kolluri, R., Kirchhausen, T., Rickles, R.J. and Berg, L.J. (1996) Identification of Itk/Tsk Src homology 3 domain ligands. *J. Biol. Chem.*, **271**, 25646-25656.
- Bunnell, S.C., Diehn, M., Yaffe, M.B., Findell, P.R., Cantley, L.C. and Berg, L.J. (2000) Biochemical interactions integrating Itk with the T cell receptor-initiated signaling cascade. *J. Biol. Chem.*, **275**, 2219-2230.
- Calderwood, D.A., Shattil, S.J. and Ginsberg, M.H. (2000) Integrins and actin filaments: reciprocal regulation of cell adhesion and signaling. *J. Biol. Chem.*, **275**, 22607-22610.
- Caron, E., Self, A.J. and Hall, A. (2000) The GTPase Rap1 controls functional activation of macrophage integrin αM β2 by LPS and other inflammatory mediators. *Curr. Biol.*, **10**, 974-978.
- Chan, A.C., Dalton, M., Johnson, R., Kong, G., Wang, T., Thoma, R. and Kurosaki, T. (1995) Activation of ZAP-70 kinase activity by phosphorylation of tyrosine 493 is required for lymphocyte antigen receptor function. *EMBO J.*, **14**, 2499-2508.
- Chan, A.S.H., Mobley, J.L., Fields, G.B. and Shimizu, Y. (1997) CD7-mediated regulation of integrin adhesiveness on human T cells involves tyrosine phosphorylation-dependent activation of phosphatidylinositol 3-kinase. *J. Immunol.*, **159**, 934-942.
- Ching, K.A., Kawakami, Y., Kawakami, T. and Tsoukas, C.D. (1999) Emt/Itk associates with activated TCR complexes: role of the pleckstrin homology domain. *J. Immunol.*, **163**, 6006-6013.

- Ching, K.A., Grasis, J.A., Taylor, P., Kawakami, Y., Kawakami, T. and Tsoukas, C.D. (2000) TCR/CD3-induced activation and binding of Emt/Itk to linker of activated T cell complexes: requirement for the Src homology 2 domain. *J. Immunol.*, **165**, 256–262.
- Denny, M.F., Patai, B. and Straus, D.B. (2000) Differential T-cell antigen receptor signaling mediated by the Src family kinases Lck and Fyn. *Mol. Cell. Biol.*, **20**, 1426–1435.
- Di Cristofano, A. and Pandolfi, P.P. (2000) The multiple roles of PTEN in tumor suppression. *Cell*, **100**, 387–390.
- Dustin, M.L. and Springer, T.A. (1989) T-cell receptor cross-linking transiently stimulates adhesiveness through LFA-1. *Nature*, **341**, 619–624.
- Epler, J.A., Liu, R., Chung, H., Ottoson, N.C. and Shimizu, Y. (2000) Regulation of  $\beta 1$  integrin-mediated adhesion by T cell receptor signaling involves ZAP-70 but differs from signaling events that regulate transcriptional activity. *J. Immunol.*, **165**, 4941–4949.
- Gibson, S., August, A., Kawakami, Y., Kawakami, T., Dupont, B. and Mills, G.B. (1996) The EMT/ITK/TSK (EMT) tyrosine kinase is activated during TCR signaling—LCK is required for optimal activation of EMT. *J. Immunol.*, **156**, 2716–2722.
- Heyeck, S.D., Wilcox, H.M., Bunnell, S.C. and Berg, L.J. (1997) Lck phosphorylates the activation loop tyrosine of the Itk kinase domain and activates Itk kinase activity. *J. Biol. Chem.*, **272**, 25401–25408.
- Hughes, P.E., Renshaw, M.W., Pfaff, M., Forsyth, J., Keivens, V.M., Schwartz, M.A. and Ginsberg, M.H. (1997) Suppression of integrin activation: a novel function of a Ras/Raf-initiated MAP kinase pathway. *Cell*, **88**, 521–530.
- Hunter, A.J. and Shimizu, Y. (1997)  $\alpha 4\beta 1$  integrin-mediated tyrosine phosphorylation in human T cells: characterization of Crk- and Fyn-associated substrates (pp105, pp115 and human enhancer of filamentation-1) and integrin-dependent activation of p59<sup>fyn</sup>. *J. Immunol.*, **159**, 4806–4814.
- Ilangumaran, S., Arni, S., Van Echten-Deckert, G., Borisch, B. and Hoessli, D.C. (1999) Microdomain-dependent regulation of Lck and Fyn protein-tyrosine kinases in T lymphocyte plasma membranes. *Mol. Biol. Cell*, **10**, 891–905.
- Iwashima, M., Irving, B.A., Van Oers, N.S.C., Chan, A.C. and Weiss, A. (1994) Sequential interactions of the TCR with two distinct cytoplasmic tyrosine kinases. *Science*, **263**, 1136–1139.
- Janes, P.W., Ley, S.C. and Magee, A.I. (1999) Aggregation of lipid rafts accompanies signaling via the T cell receptor. *J. Cell Biol.*, **147**, 447–461.
- Kane, L.P., Lin, J. and Weiss, A. (2000) Signal transduction by the TCR for antigen. *Curr. Opin. Immunol.*, **12**, 242–249.
- Katagiri, K., Hattori, M., Minato, N., Irie, S., Takatsu, K. and Kinashi, T. (2000) Rap1 is a potential activation signal for leukocyte function-associated antigen 1 distinct from protein kinase C and phosphatidylinositol 3-OH kinase. *Mol. Cell. Biol.*, **20**, 1956–1969.
- Kinashi, T., Asaoka, T., Setoguchi, R. and Takatsu, K. (1999) Affinity modulation of very late antigen-5 through phosphatidylinositol 3-kinase in mast cells. *J. Immunol.*, **162**, 2850–2857.
- Kivens, W.J. and Shimizu, Y. (1998) Tracking integrin-mediated adhesion using green fluorescent protein and flow cytometry. In Guan, J.L. (ed.), *Signaling Through Cell Adhesion Molecules*. CRC Press, Boca Raton, FL, pp. 219–234.
- Kivens, W.J., Hunt, S.W., III, Mobley, J.L., Zell, T., Dell, C.L., Bierer, B.E. and Shimizu, Y. (1998) Identification of a proline-rich sequence in the CD2 cytoplasmic domain critical for regulation of integrin-mediated adhesion and activation of phosphoinositide 3-kinase. *Mol. Cell. Biol.*, **18**, 5291–5307.
- Klarlund, J.K., Guilherme, A., Holik, J.J., Virbasius, J.V., Chawla, A. and Czech, M.P. (1997) Signaling by phosphoinositide-3,4,5-trisphosphate through proteins containing pleckstrin and Sec7 homology domains. *Science*, **275**, 1927–1930.
- Kolanus, W., Nagel, W., Schiller, B., Zeitlmann, L., Godar, S., Stockinger, H. and Seed, B. (1996)  $\alpha L\beta 2$  integrin/LFA-1 binding to ICAM-1 induced by cytohesin-1, a cytoplasmic regulatory molecule. *Cell*, **86**, 233–242.
- Kucik, D.F., Dustin, M.L., Miller, J.M. and Brown, E.J. (1996) Adhesion-activating phorbol ester increases the mobility of leukocyte integrin LFA-1 in cultured lymphocytes. *J. Clin. Invest.*, **97**, 2139–2144.
- Langlet, C., Bernard, A.-M., Drevot, P. and He, H.-T. (2000) Membrane rafts and signaling by the multichain immune recognition receptors. *Curr. Opin. Immunol.*, **12**, 250–255.
- Lemmon, M.A., Falasca, M., Ferguson, K.M. and Schlessinger, J. (1997) Regulatory recruitment of signalling molecules to the cell membrane by pleckstrin-homology domains. *Trends Cell Biol.*, **7**, 237–242.
- Li, Z., Wahl, M.I., Eguinoa, A., Stephens, L.R., Hawkins, P.T. and Witte, O.N. (1997) Phosphatidylinositol 3-kinase- $\gamma$  activates Bruton's tyrosine kinase in concert with Src family kinases. *Proc. Natl Acad. Sci. USA*, **94**, 13820–13825.
- Liao, X.C. and Littman, D.R. (1995) Altered T cell receptor signaling and disrupted T cell development in mice lacking Itk. *Immunity*, **3**, 757–769.
- Lin, J., Weiss, A. and Finco, T.S. (1999) Localization of LAT in glycolipid-enriched microdomains is required for T cell activation. *J. Biol. Chem.*, **274**, 28861–28864.
- Liu, K.Q., Bunnell, S.C., Gurniak, C.B. and Berg, L.J. (1998) T cell receptor-initiated calcium release is uncoupled from capacitative calcium entry in Itk-deficient T cells. *J. Exp. Med.*, **187**, 1721–1727.
- Lu, Y.L., Cuevas, B., Gibson, S., Khan, H., Lapushin, R., Imboden, J. and Mills, G.B. (1998) Phosphatidylinositol 3-kinase is required for CD28 but not CD3 regulation of the TEC family tyrosine kinase EMT/ITK/TSK: functional and physical interaction of EMT with phosphatidylinositol 3-kinase. *J. Immunol.*, **161**, 5404–5412.
- Mobley, J.L., Ennis, E. and Shimizu, Y. (1994) Differential activation-dependent regulation of integrin function in cultured human T-leukemic cell lines. *Blood*, **83**, 1039–1050.
- Moran, M. and Miceli, M.C. (1998) Engagement of GPI-linked CD48 contributes to TCR signals and cytoskeletal reorganization: a role for lipid rafts in T cell activation. *Immunity*, **9**, 787–796.
- Nagel, W., Zeitlmann, L., Schilcher, P., Geiger, C., Kolanus, J. and Kolanus, W. (1998) Phosphoinositide 3-OH kinase activates the  $\beta 2$  integrin adhesion pathway and induces membrane recruitment of cytohesin-1. *J. Biol. Chem.*, **273**, 14853–14861.
- Nore, B.F. et al. (2000) Redistribution of Bruton's tyrosine kinase by activation of phosphatidylinositol 3-kinase and Rho-family GTPases. *Eur. J. Immunol.*, **30**, 145–154.
- O'Rourke, A.M., Shao, H. and Kaye, J. (1998) Cutting edge: a role for p21<sup>ras</sup>/MAP kinase in TCR-mediated activation of LFA-1. *J. Immunol.*, **161**, 5800–5803.
- O'Rourke, L.M., Tooze, R., Turner, M., Sandoval, D.M., Carter, R.H., Tybulewicz, V.L. and Fearon, D.T. (1998) CD19 as a membrane-anchored adaptor protein of B lymphocytes: costimulation of lipid and protein kinases by recruitment of Vav. *Immunity*, **8**, 635–645.
- Perez-Villar, J.J. and Kanner, S.B. (1999) Regulated association between the tyrosine kinase Emt/Itk/Tsk and phospholipase-C $\gamma 1$  in human T lymphocytes. *J. Immunol.*, **163**, 6435–6441.
- Pogue, S.L., Kurosaki, T., Bolen, J. and Herbst, R. (2000) B cell antigen receptor-induced activation of Akt promotes B cell survival and is dependent on Syk kinase. *J. Immunol.*, **165**, 1300–1306.
- Qiu, Y., Robinson, D., Pretlow, T.G. and Kung, H.J. (1998) Etk/Bmx, a tyrosine kinase with a pleckstrin-homology domain, is an effector of phosphatidylinositol 3'-kinase and is involved in interleukin 6-induced neuroendocrine differentiation of prostate cancer cells. *Proc. Natl Acad. Sci. USA*, **95**, 3644–3649.
- Reedquist, K.A., Ross, E., Koop, E.A., Wolthuis, R.M., Zwartkruis, F.J., van Kooyk, Y., Salmon, M., Buckley, C.D. and Bos, J.L. (2000) The small GTPase, Rap1, mediates CD31-induced integrin adhesion. *J. Cell Biol.*, **148**, 1151–1158.
- Romzek, N.C., Harris, E.S., Dell, C.L., Skronek, J., Hasse, E., Reynolds, P.J., Hunt, S.W., III and Shimizu, Y. (1998) Use of a  $\beta 1$  integrin-deficient human T cell to identify  $\beta 1$  integrin cytoplasmic domain sequences critical for integrin function. *Mol. Biol. Cell*, **9**, 2715–2727.
- Salim, K. et al. (1996) Distinct specificity in the recognition of phosphoinositides by the pleckstrin homology domains of dynamin and Bruton's tyrosine kinase. *EMBO J.*, **15**, 6241–6250.
- Salojin, K.V., Zhang, J., Meagher, C. and Delovitch, T.L. (2000) ZAP-70 is essential for the T cell antigen receptor-induced plasma membrane targeting of SOS and Vav in T cells. *J. Biol. Chem.*, **275**, 5966–5975.
- Schaeffer, E.M. and Schwartzberg, P.L. (2000) Tec family kinases in lymphocyte signaling and function. *Curr. Opin. Immunol.*, **12**, 282–288.
- Schaeffer, E.M. et al. (1999) Requirement for Tec kinases Rlk and Itk in T cell receptor signaling and immunity. *Science*, **284**, 638–641.
- Shan, X.C. and Wange, R.L. (1999) Itk/Emt/Tsk activation in response to CD3 cross-linking in Jurkat T cells requires ZAP-70 and Lat and is independent of membrane recruitment. *J. Biol. Chem.*, **274**, 29323–29330.
- Shan, X.C., Czar, M.J., Bunnell, S.C., Liu, P.H., Liu, Y.S., Schwartzberg, P.L. and Wange, R.L. (2000) Deficiency of PTEN in Jurkat T cells causes constitutive localization of Itk to the plasma membrane and

- hyperresponsiveness to CD3 stimulation. *Mol. Cell. Biol.*, **20**, 6945–6957.
- Shimizu, Y. and Hunt, S.W., III (1996) Regulating integrin-mediated adhesion: one more function for PI 3-kinase? *Immunol. Today*, **17**, 565–573.
- Shimizu, Y., van Seventer, G.A., Horgan, K.J. and Shaw, S. (1990) Regulated expression and binding of three VLA ( $\beta$ 1) integrin receptors on T cells. *Nature*, **345**, 250–253.
- Shimizu, Y., Rose, D.M. and Ginsberg, M.H. (1999) Integrins and the immune response. *Adv. Immunol.*, **72**, 325–380.
- Sideras, P. and Smith, C.I. (1995) Molecular and cellular aspects of X-linked agammaglobulinemia. *Adv. Immunol.*, **59**, 135–223.
- Stevenson, J.M., Perera, I.Y. and Boss, W.F. (1998) A phosphatidylinositol 4-kinase pleckstrin homology domain that binds phosphatidylinositol 4-monophosphate. *J. Biol. Chem.*, **273**, 22761–22767.
- Stewart, M.P., Cabañas, C. and Hogg, N. (1996) T cell adhesion to intercellular adhesion molecule-1 (ICAM-1) is controlled by cell spreading and the activation of integrin LFA-1. *J. Immunol.*, **156**, 1810–1817.
- Turner, J.M., Brodsky, M.H., Irving, B.A., Levin, S.D., Perlmutter, R.M. and Littman, D.R. (1990) Interaction of the unique N-terminal region of tyrosine kinase p56<sup>lck</sup> with cytoplasmic domains of CD4 and CD8 is mediated by cysteine motifs. *Cell*, **60**, 755–765.
- van Kooyk, Y., van de Wiel-van Kemenade, P., Weder, P., Kuijpers, T.W. and Figdor, C.G. (1989) Enhancement of LFA-1-mediated cell adhesion by triggering through CD2 or CD3 on T lymphocytes. *Nature*, **342**, 811–813.
- van Kooyk, Y., Van Vliet, S.J. and Figdor, C.G. (1999) The actin cytoskeleton regulates LFA-1 ligand binding through avidity rather than affinity changes. *J. Biol. Chem.*, **274**, 26869–26877.
- Wang, X.D., Gjörlöf-Wingren, A., Saxena, M., Pathan, N., Reed, J.C. and Mustelin, T. (2000) The tumor suppressor PTEN regulates T cell survival and antigen receptor signaling by acting as a phosphatidylinositol 3-phosphatase. *J. Immunol.*, **164**, 1934–1939.
- Ward, S.G., Ley, S.C., MacPhee, C. and Cantrell, D.A. (1992) Regulation of D-3 phosphoinositides during T cell activation via the T cell antigen receptor/CD3 complex and CD2 antigens. *Eur. J. Immunol.*, **22**, 45–49.
- Woods, M.L., Cabañas, C. and Shimizu, Y. (2000) Activation-dependent changes in soluble fibronectin binding and expression of  $\beta$ 1 integrin activation epitopes in T cells: relationship to T cell adhesion and migration. *Eur. J. Immunol.*, **30**, 38–49.
- Xavier, R. and Seed, B. (1999) Membrane compartmentation and the response to antigen. *Curr. Opin. Immunol.*, **11**, 265–269.
- Xavier, R., Brennan, T., Li, Q.Q., McCormack, C. and Seed, B. (1998) Membrane compartmentation is required for efficient T cell activation. *Immunity*, **8**, 723–732.
- Zell, T., Hunt, S.W., III, Finkelstein, L.D. and Shimizu, Y. (1996) CD28-mediated upregulation of  $\beta$ 1 integrin-mediated adhesion involves phosphatidylinositol 3-kinase. *J. Immunol.*, **156**, 883–886.
- Zhang, W.G., Tribble, R.P. and Samelson, L.E. (1998) LAT palmitoylation: its essential role in membrane microdomain targeting and tyrosine phosphorylation during T cell activation. *Immunity*, **9**, 239–246.
- Zhang, Z.H., Vuori, K., Wang, H.G., Reed, J.C. and Ruoslahti, E. (1996) Integrin activation by R-ras. *Cell*, **85**, 61–69.

Received September 29, 2000; revised December 28, 2000;  
accepted January 18, 2001