

CATALOGED
SMOTA-RTS

06210



+

FINAL TECHNICAL REPORT
VARIABLE SPEED FAN DRIVE ASSEMBLY

LIQUID DRIVE CORPORATION CONTRACT DA-20-018-ORD-23658

Detroit Ordnance District Project No. 602 LWO 8033

All work performed under technical supervision of
Mr. John Zeno, Project Engineer, Ordnance Tank
Automotive Command, Detroit Arsenal, Center Line,
Michigan

Distribution - Unlimited

Prepared By H. E. Ressler
August 13, 1962

DISTRIBUTION STATEMENT A
Approved for Public Release
Distribution Unlimited

Reproduced From
Best Available Copy

20011010 131

TECHNICAL LIBRARY
REFERENCE COPY

AN28514

XX
4424.1

"AD _____" and "ACCESSION _____" " 9"

Final Technical Report - Variable Speed Fan Drive Assembly. Engine Cooling Systems. Liquid Drive Corporation, Holly, Michigan Contract No. DA-20-018-ORD-23658 Dept. of Army Project No. PR61-125, 549-02-002 No. of Pages 15 Ord Dist Project #602-LWO-8033 This report covers designing, building and testing of a Variable Speed Fan Drive. Speed control automatic from 0 to approx. 4900 rpm governed by engine coolant temperature. Unit includes a fail safe device which operates the fan at maximum speed in the event of a control failure. Unit also includes a deepwater fording switch to reduce fan speed when engine

compartment is flooded. Direction of rotation is counter-clockwise reviewed from output end. Tests performed on unit included a functional check on speed modulation, declutching, fail safe devices and deep water fording switch operation. All these tests were performed using a 1765 rpm electric motor. A high speed test of approx 4800 rpm was also made to assure satisfactory operation at elevated speed. Results obtained from above tests indicate that fan drive will perform satisfactorily but final evaluation is best obtained by operating under actual engine conditions.

Prepared by H. E. Ressler, August 13, 1962

UNCLASSIFIED

FINAL TECHNICAL REPORT
VARIABLE SPEED FAN DRIVE ASSEMBLY

LIQUID DRIVE CORPORATION CONTRACT DA-20-018-ORD-23658

Detroit Ordnance District Project No. 602 LWO 8033

All work performed under technical supervision of
Mr. John Zeno, Project Engineer, Ordnance Tank
Automotive Command, Detroit Arsenal, Center Line,
Michigan

Distribution - Unlimited

Prepared By H. E. Rossler
August 13, 1962

TABLE OF CONTENTS

	PAGE
Object and Summary	1 - 4
Conclusions and Recommendations	5 - 6
Details:	7 - 14
Liquid Drive Selection	7
Bearing Analysis	8 - 9
General Design	9
Description of Operation (control system)	9 - 11
Control System Schematic	12
Flood Control Wiring Diagram	13
Test Setup Schematic	14
Initial Distribution List	15

ABSTRACT

"AD _____" and "ACCESSION _____"
Final Technical Report - Variable Speed Fan Drive Assembly.
Engine Cooling Systems.
Liquid Drive Corporation, Holly, Michigan
Contract No. DA-20-018-ORD-23658
Dept. of Army Project No. PR21-125, 549-02-002
No. of Pages 15 Ordnance District Project #502-LWO-8033

This report covers designing, building and testing of a variable speed fan drive. Speed control automatic from 0 to approximately 4900 rpm governed by engine coolant temperature. Unit includes a fail safe device which operates the fan at maximum speed in the event of a control failure. Unit also includes a deepwater fording switch to reduce fan speed when engine compartment is flooded. Direction of rotation is counter-clockwise viewed from output end.

Tests performed on unit included a functional check on speed modulation, declutching, fail safe devices and deep water fording switch operation. All these tests were performed using a 1765 rpm electric motor. A high speed test of approximately 4800 rpm was also made to assure satisfactory operation at elevated speed.

Results obtained from above tests indicate that fan drive will perform satisfactorily, but final evaluation is best obtained by operating under actual engine conditions.

Prepared by H. E. Ressler
August 13, 1962
UNCLASSIFIED

OBJECT

- A. Design, fabricate and test a light weight variable speed Liquid Drive for the fan drive assembly of light weight highly mobile combat vehicles.
1. The Liquid Drive fan assembly to be interchangeable with the fan drive assembly shown on Ordnance drawing Number DTA-90710.
 2. The Liquid Drive to be rated @ 70 hp input @ approximately 5060 rpm input speed.
 3. The Liquid Drive fan drive assembly to incorporate the features as follows:
 - a. Speed modulation from 0 to maximum speed of approximately 4900 rpm (allowing for 3% Liquid Drive slip.)
 - b. Fan rotation to be counter-clockwise viewed from output or fan end.
 - c. Automatic control of fan speed depending upon engine coolant temperature of 170°-230° F. and any engine speed (600 - 2200 rpm.) Fan speed to reach maximum speed at coolant temperature 220° F. and over.
 - d. Fail-safe protection to be incorporated to achieve maximum fan speed in event of automatic control failure.
 - e. Deep water fording switch location beneath fan to reduce fan speed to zero when engine compartment is flooded.
 - f. Lubrication, Liquid Drive and control valve supply to be received from oil supply of main engine.
 - g. A service life of five hundred (500) hours at full capacity in an environment of 130° F. ambient temperature.

SUMMARY

A. Design

1. Liquid Drive sized in accordance to fan rating and available input speed. A size SPM4-205 (8.120" profile dia) was selected. Expect performance will be 97% efficient at full coupling.
2. Liquid Drive Assembly consisting of housing, rotors,

shafts, controls, etc. designed, detailed and checked.

3. Direction of rotation changed from clockwise to counter-clockwise rotation. Assembly and detail drawings changed accordingly.
4. Details released for fabrication and procurement.

B. Fabrication and Assembly

1. Commenced fabrication of necessary tooling to facilitate fabrication of details.
2. Initiated procurement of "purchased components".
3. Commenced fabrication of details.
4. Completed fabrication and procurement of details.
5. Assembled Liquid Drive Assembly.

C. Functional Tests

1. General Aspects

In accordance with the contractual agreement, only functional tests will be performed at the vendors plant. These tests will be at reduced speed (approximately 1750 rpm.) Extensive tests and final evaluation will be conducted by the Ordnance Tank Automotive Command.

2. Test Stand

A test stand was designed and constructed to drive the Liquid Drive at 1765 rpm. A simulated coolant circuit was built up to provide temperature input to control system.

3. Test conditions

An oil flow of 1 gpm @ 140° F. and 15 PSI pressure was used to supply coupling and control valve. Cities Service 150 T oil was used. Water brake load equivalent to 3.0 hp @ 1765 rpm.

4. Declutch Test

When coolant temperature is less than 200° F., the output shaft of the Liquid Drive is stationary or in a "declutched" position. When motor is first started the output shaft will rotate until control pressure is sufficient to declutch the unit.

5. Speed Regulation Test

When the coolant temperature is in excess of 200° F., the output shaft will rotate, reaching a maximum speed of 1720 rpm @ approximately 210° F.

The unit will continue to run at maximum speed until coolant temperature is lowered to approximately 200° F. or below. When temperature reaches approximately 180° F. the output shaft will cease to rotate. Intermediate temperatures result in intermediate speeds. The actual speed to temperature relationship will vary slightly with supply and control oil temperature and pressure.

By removing the low temperature sensing bulb from the coolant circuit (simulating a sensing bulb or capillary tube failure) and raising the temperature of the coolant to 230° F. a maximum speed of 1720 rpm was achieved. When temperature was lowered to 210° F. the Liquid Drive declutched.

6. Deep Water Fording Switch Test

With an output shaft speed of 1720 rpm, the electrode tip controlling the solenoid valve was plunged in water, resulting in a declutch in 30 seconds.

7. Fail Safe Test

Simulating a control valve failure, by closing off the control supply resulting in a pressure loss to the control valve, the return spring contained in the scoop tube block caused the Liquid Drive to operate at 1720 rpm regardless of coolant temperature.

8. Minimum Slip Test

With a coolant temperature of 210° F. an output speed of 1720 rpm was achieved. An efficiency of 97.3%.

9. Maximum Speed Test

SEM4-205 Liquid Drive and test stand assembly setup with

25 hp @ 1750 rpm electric motor with 9.4 P.D. sheave on driving shaft and 3.4 P.D. sheave on driven shaft. Load was removed from water brake. A speed of 4600 rpm was achieved. Ran to check for unbalance, scoop tube actuation and filling characteristics.

10. Liquid Drive with Fan and Fan Shroud Performance Test

Removing the water brake and substituting fan DTA-64333 and fan shroud DTA-64334 with a supply oil flow of 1 gpm @ 140° F., a coolant temperature of 210° F. and an input speed of 1770 rpm, the output speed was 1725 rpm or 97.5% efficient.

When flood control electrode was submerged, output speed was reduced from 1725 rpm to 500 rpm in 10 seconds. Fan continued to windmill at approximately 300 rpm.

Speed modulation points same as previous tests.

CONCLUSIONS AND RECOMMENDATIONS

A. Liquid Drive Rating

1. Functional tests with prony brake and with fan indicate the efficiency of the Liquid Drive (at full coupling) to be within predicated values. (approximately 97% efficiency.)

The torque transmitting capacity of the Liquid Drive and the torque requirements of the fan are proportional to the square of the speed. Consequently the performance obtained at reduced speeds, such as those used in the functional test program, is indicative of what can be expected at the rated speed.

B. Control System

1. Functional tests of speed versus temperature regulation, fail safe and deep water fording provisions indicate satisfactory operation.

It should be pointed out that the ability of the control system to regulate the Liquid Drive output speed as a function of coolant temperature is dependent on the characteristics of the coolant system in the actual application. Thermal inertia or temperature lag of the coolant system may result in a low frequency speed variation that may be objectionable. In this event it may be necessary to modify the control system.

2. We also would like to point out that it may be desirable to locate the low temperature sensing bulb at radiator exit to engine and secondary or high temperature sensing bulb at engine exit to radiator. This would undoubtedly require different temperature range bulbs than those existing on unit.
3. The deep water fording switch solenoid valve is at present mounted directly on the Liquid Drive sump, but could be relocated.
4. With fan assembled on Liquid Drive output shaft, when unit is "declutched" by deep water fording switch, the fan will "windmill" at approximately 300-350 rpm with a 1 gpm oil supply to Liquid Drive. More or less flow will result in greater or lesser fan speed. If the "windmilling" is undesirable, the supply flow to the Liquid Drive could be by-passed. This could be

accomplished by use of a solenoid valve similar to the deep water fording switch device.

5. The modulation range of the control valve is set to start initial rotation at approximately 200° F., reaching max. speed at 210° F., hold speed to approximately 200° F., and modulate downwards to approximately 160° F.

A minor adjustment in the modulation range may be made by adjusting the lower spool of the control valve. This is accomplished by loosening jam nut and turning sleeve clockwise for lower temperature range or counter-clockwise for higher temperature range, retighten nut.

6. We recommend use of a pressure regulator which we are furnishing (Leslie 300-4) or equivalent to be installed in the supply line ahead of the control valve and adjusted for 15 PSI oil pressure.

DETAILS

1. Liquid Drive Size Selection

a. Fan Rating: 75 hp @ 7075 rpm*

*Note: This is not consistent with engine speed.

b. Input speed to Liquid Drive @ 2200 rpm

$$N_p = 2200 \times 2.3 = 5060 \text{ rpm}$$

c. Adjusted Fan Rating

1. Assume 3% minimum slip thru Liquid Drive; therefore fan speed (max) will be:

$$N_s \text{ Max} = N_p (.97) = 5060 (.97) = 4900 \text{ rpm}$$

2. Adjusted Fan Rating (actual)

Since maximum fan speed is 4900 rpm

$$\text{fan hp @ 4900 rpm} = 75 \left(\frac{4900}{5075} \right)^3 = 67.5 \text{ hp}$$

$$\text{say hp} = 68 @ 4900 \text{ rpm}$$

d. Required input hp to Liquid Drive

$$\text{fan hp} = 68$$

Assumed Liquid Drive efficiency = 100% -% slip.

$$\text{efficiency} = 100 - 3 = 97\%$$

$$\text{HP input} = \frac{\text{fan hp}}{\text{eff.}} = \frac{68}{.97} = 70 \text{ hp}$$

e. Liquid Drive Size

$$K = \frac{\text{hp input}}{\left(\frac{N_p}{100} \right)^3 D^5}$$

D = Profile diameter of Liquid Drive in meters

K = Proportionality factor relating Liquid Drive performance to slip. From experience at max. fill:

$$\% \text{ slip} = 2K$$

N_p = Max. input speed rpm

For 3% slip $K = 1.5$ solving for D when hp input = 70,

$$N_p = 5060 \text{ and } K = 1.5$$

$$D^5 = \frac{\text{hp input}}{\left(\frac{N_p}{100} \right)^3 K} = \frac{70}{(50.6)^3 (1.5)}$$

$$D^5 = .000361 \text{ (slide rule accuracy)}$$

$$D = .2045 \text{ meters or } 8.05" \text{ (slide rule accuracy)}$$

Set profile diameter at 8.12"

2. Bearing Analysis

A. General

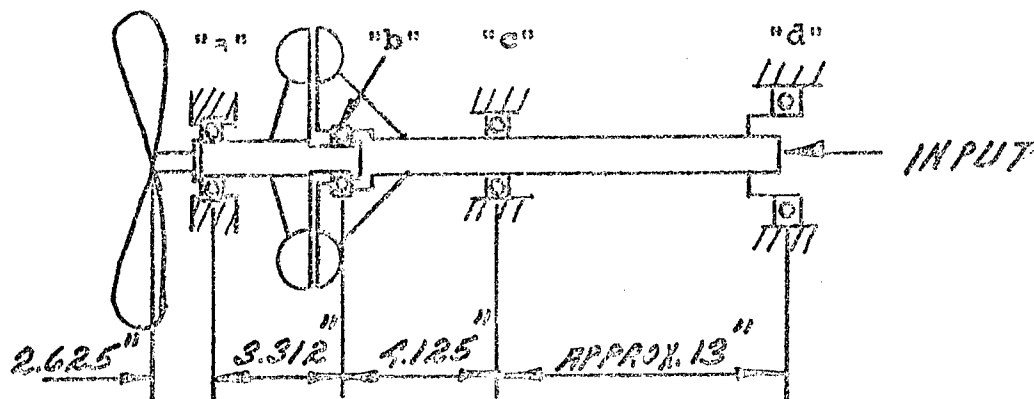

Bearing (a) accommodates fan thrust, fan weight.

Bearing (b) accommodates Liquid Drive thrust, radial components of fan weight.

Bearing (c) accommodates radial components of fan weight.

Assumptions

1. Fan weight: 50#
2. Liquid Drive weight: negligible relative to fan weight and bearing capacities.
3. Thrust load of fan taken entirely by bearing "a" and that this bearing is adequately sized since it is the identical bearing used in previous friction clutch application.
4. Drive shaft is well fitted into bevel gear with a minimum of misalignment. Bevel gear bearing will then support this shaft end.
5. Bearing "c" in the original friction clutch application was a 6208 with a dynamic capacity of 5050 per SKF. This bearing was changed to a 6307 with a dynamic capacity of 5750. The bearing will see virtually the same loads as experienced in the friction clutch application; therefore it was assumed that the substitution of the 6307 bearing is permissible and adequate for this application.

B. Life of bearing "b"

1. Radial reaction @ "b"

$$R_b = 50 \left(\frac{2.625}{3.312} \right) = 39.6 \text{ say } 40\#$$

2. Thrust Due to Liquid Drive

From experience expected thrust = 425#
 $F_a = 425\#$

3. Bearing Life

Bearing Size 6305

Equivalent load $P = .37 (V) (R_p) + Y F_a$
(ref SKF procedure)

$$P = .37 (1.2) (40) + 1.25 (425)$$
$$P = 17.8 + 532 + 550\#$$

Dynamic bearing capacity $C = 3650$

$$\frac{C}{P} = \frac{3650}{550} = 6.6$$

Bearing "b" operates at $N = N_p - N_s$ or the difference in speed between the input and output shaft. Assume this differential speed to be 3400 rpm (conservative.)

B-10 life per SKF tables is 71000 hrs;
therefore bearing "b" is suitable

3. General Design

1. A new outer housing to contain the Liquid Drive rotors was designed, maintaining the same mounting base, mounting flanges and holes and drain as previous housing.
2. Input and output shaft extensions are same as existing fan drive assembly.
3. Utilized existing cover DTA-64183 and studs DTA-64339.

4. Description of Operation - Control System (Reference control system schematic)

- a. Prior to engine start pilot stage is open, main stage spool is in extreme right position, scoop tube is in the maximum speed (clutch) position.
- b. As engine starts and oil pressure is developed, oil is ported thru main spool to rod end of actuator de-clutching the Liquid Drive.

- c. When engine coolant temperature raises to approximately 170-180° F. pilot stage spool commences to move to the left causing the pressure (herein termed "control pressure") in the fluid system down stream of the orifice to build up in accordance with pilot stage spool position.
- d. As "control pressure" builds up it acts against the right hand end of the main spool causing the main spool to shift to the left which in turn commences to discontinue the supply of oil to the actuator "rod end" and to introduce oil to the actuator "head end". Thus the scoop tube is caused to begin its movement from the declutched position towards the clutch position and as a result commence to bring the fan up to speed.
- e. As the fan commences to lower the coolant temperature the pilot stage reacts to lower the control pressure to cause the fan speed to decrease.
- f. A dual reliability feature is provided by a standby pilot stage. This stage is normally inoperative unless the normal pilot stage fails. The temperature setting of the standby stage is slightly higher than the normal pilot stage so as to not interfere with the operation of the latter.
- g. A flooding device is provided to declutch the fan in the event the fan compartment commences to fill with water. This is accomplished by a solenoid operated (normally closed) valve that upon opening vents the pilot stage system (reducing control pressure) and allows the main stage spool to be returned to the extreme right position. This will bring about rapid declutching of the Liquid Drive. The solenoid valve is energized by an electrical signal received via a relay from a water sensitive probe. The probe will be located in position to detect the presence of water.
- h. The variable orifice is used to throttle pilot stage flow so that oil consumption can be conserved and to facilitate the function of the flooding device.
- i. The control system utilizes a double acting actuator so as to have maximum force potential to move the scoop tube in either direction.
- j. The maximum pressure required to move the main stage spool to the extreme left, against its return spring, is less than

15 PSI. Likewise the maximum pressure required to declutch the Liquid Drive (move the scoop tube to the extreme right) is 15 PSI.

CONTROL SYSTEM SCHEMATIC

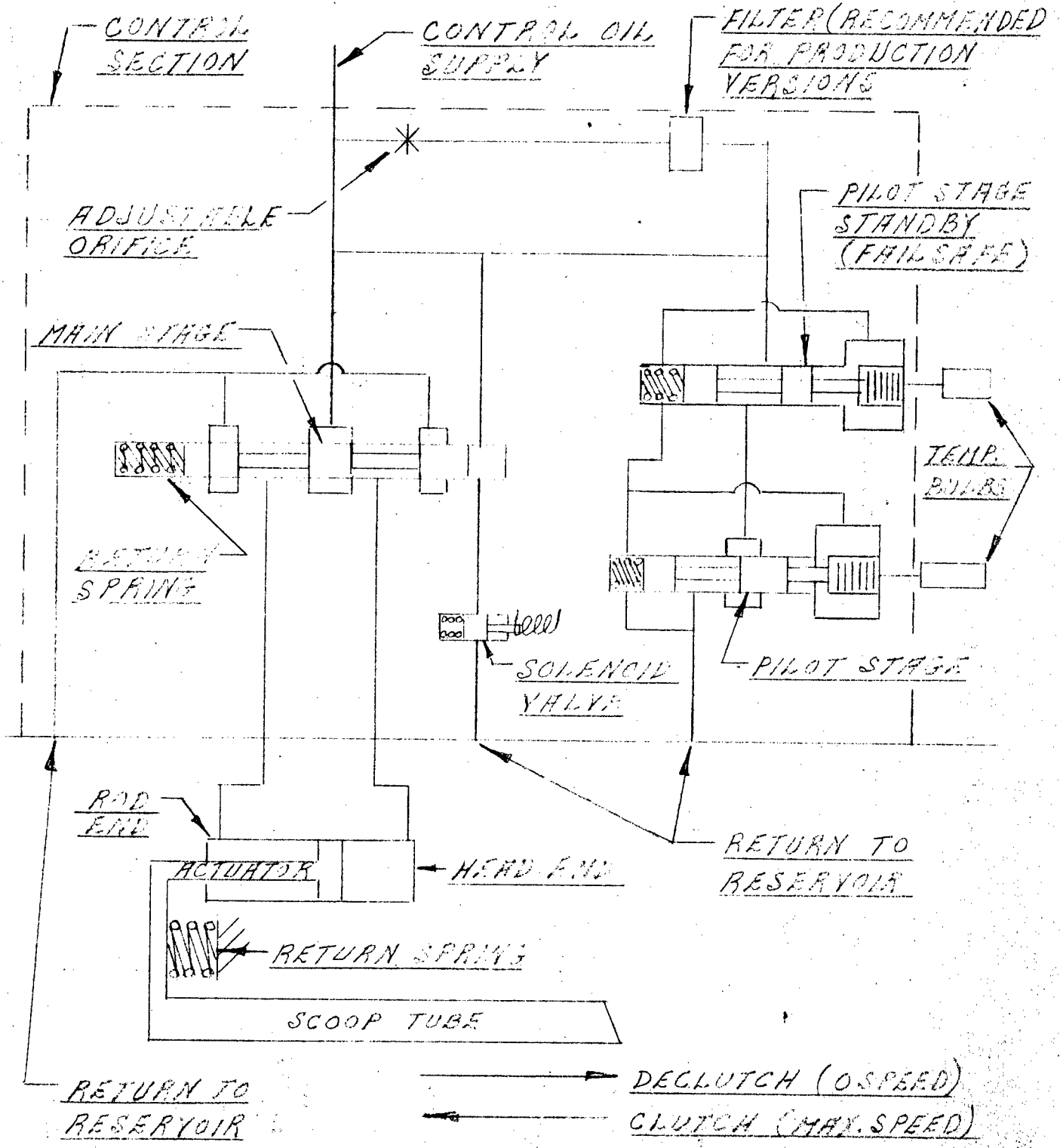

FLOOD CONTROL WIRING DIAGRAM

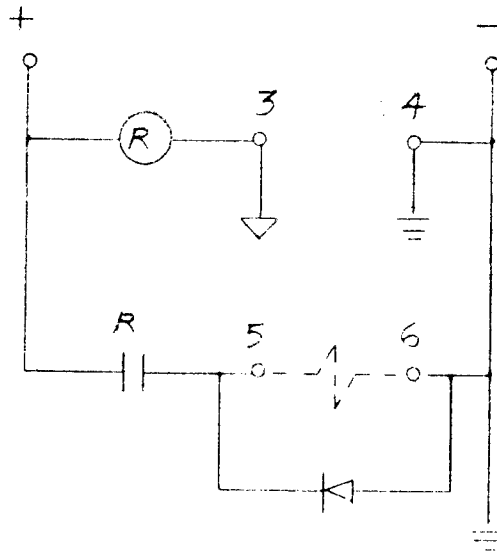

INSTALLATION: Mount controlbox vertically and position electrode fitting so the brass tip inside the pipe shield is at the level at which the solenoid valve is to be energized to stop the fan. Small circles on wiring diagram represent terminals provided for external connections. Connect the + and - terminals to 24 volt D.C. supply, being sure the polarity is correct. Connect terminal 3 to the electrode, and terminal 4 to a positive ground connection on the pipe electrode shield. Connect terminals 5 and 6 to 24 volt D.C. normally closed solenoid valve.

OPERATION: The relay will be energized to open the solenoid valve when the level is above the electrode tip and deenergize to close the valve when the level is below the electrode tip.

SPM4-205 FAN DRIVE ASSY. TEST SET UP

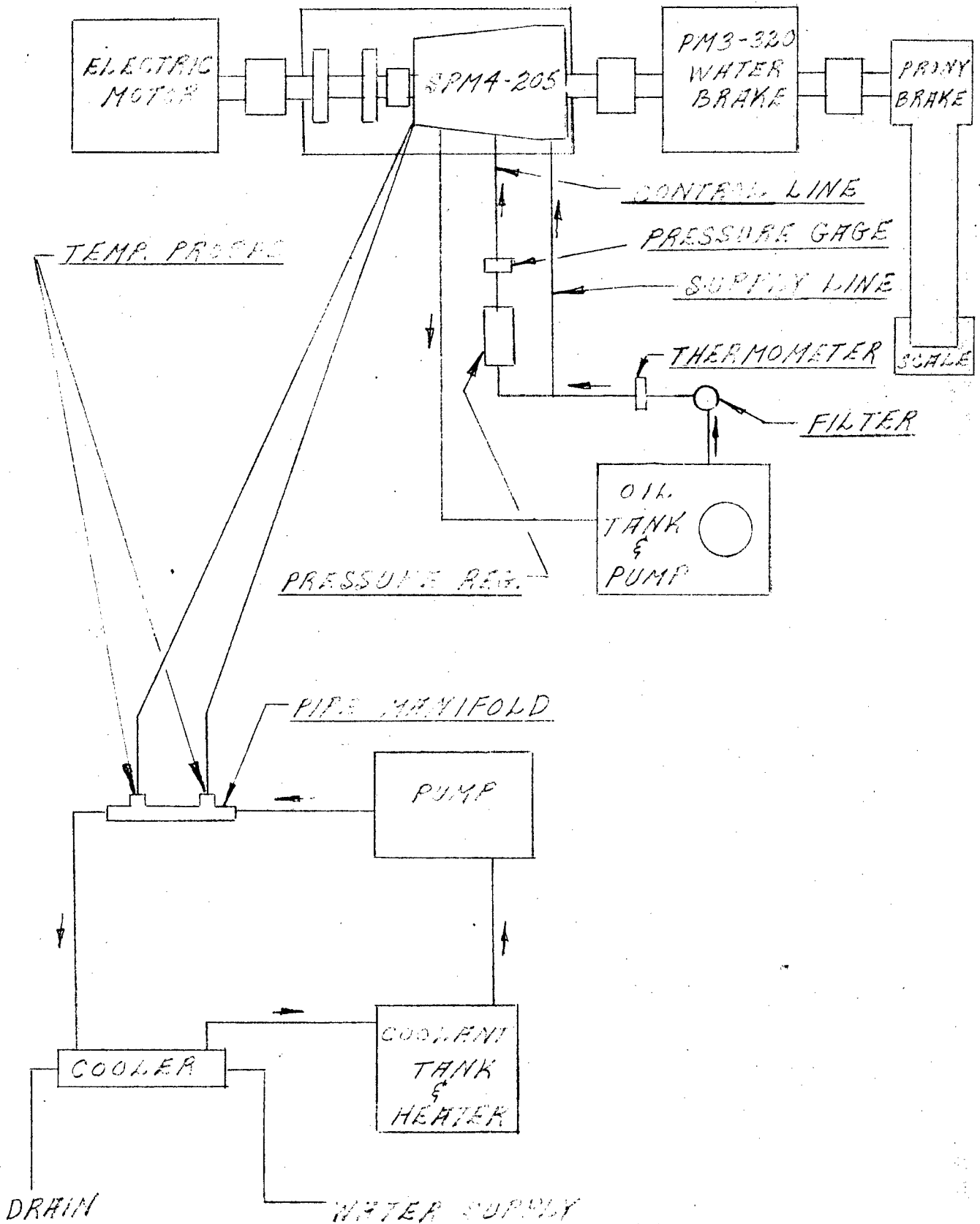

INITIAL DISTRIBUTION LIST

Contracting Officer - 2 copies and master reproducible

Ordnance Tank Automotive Command, Detroit Arsenal, Center Line,
Michigan - Attention: ORDAC-RP - 5 copies

Liquid Drive Corporation, Holly, Michigan - 4 copies

DELIVERED BY LIQUID DRIVE CORPORATION
PURSUANT TO CONTRACT NO. DA-20-018-ORD-23653
GOVERNMENT'S USE CONTROLLED BY GENERAL PROVISION
OF THE CONTRACT WHICH IS ASPR 9-203.1 AND 9-203.4

"AD" and "ACQUISITION"

Final Technical Report - Variable Speed Fan Drive Assembly. Engine Cooling Systems. Liquid Drive Corporation, Holly, Michigan Contract No. DA-20-019-ORD-23558 Dept. of Army Project No. D851-125, 549-02-002 No. of Pages 150rd Dist Project #502-LMP-0033 This report covers designing, building and testing of a Variable Speed Fan Drive. Speed control automatic from 0 to approx. 4900 rpm governed by engine coolant temperature. Unit includes a fail safe device which operates the fan at maximum speed in the event of a control failure. Unit also includes a deawater feeding switch to reduce fan speed when engine

"AD" and "ACQUISITION"

Final Technical Report - Variable Speed Fan Drive Assembly. Engine Cooling Systems. Liquid Drive Corporation, Holly, Michigan Contract No. DA-20-019-ORD-23558 Dept. of Army Project No. D851-125, 549-02-002 No. of Pages 150rd Dist Project #502-LMP-0033 This report covers designing, building and testing of a Variable Speed Fan Drive. Speed control automatic from 0 to approx. 4900 rpm governed by engine coolant temperature. Unit includes a fail safe device which operates the fan at maximum speed in the event of a control failure. Unit also includes a deawater feeding switch to reduce fan speed when engine

"AD" and "ACQUISITION"

Final Technical Report - Variable Speed Fan Drive Assembly. Engine Cooling Systems. Liquid Drive Corporation, Holly, Michigan Contract No. DA-20-019-ORD-23558 Dept. of Army Project No. D851-125, 549-02-002 No. of Pages 150rd Dist Project #502-LMP-0033 This report covers designing, building and testing of a Variable Speed Fan Drive. Speed control automatic from 0 to approx. 4900 rpm governed by engine coolant temperature. Unit includes a fail safe device which operates the fan at maximum speed in the event of a control failure. Unit also includes a deawater feeding switch to reduce fan speed when engine

"AD" and "ACQUISITION"

Final Technical Report - Variable Speed Fan Drive Assembly. Engine Cooling Systems. Liquid Drive Corporation, Holly, Michigan Contract No. DA-20-019-ORD-23558 Dept. of Army Project No. D851-125, 549-02-002 No. of Pages 150rd Dist Project #502-LMP-0033 This report covers designing, building and testing of a Variable Speed Fan Drive. Speed control automatic from 0 to approx. 4900 rpm governed by engine coolant temperature. Unit includes a fail safe device which operates the fan at maximum speed in the event of a control failure. Unit also includes a deawater feeding switch to reduce fan speed when engine