



US Army Corps
of Engineers®

Engineer Research and
Development Center

20011015 138

Performance Analysis of Natural Gas Cooling Technology at Warner-Robins AFB, GA

Fiscal Year 2000

William T. Brown, III

August 2001

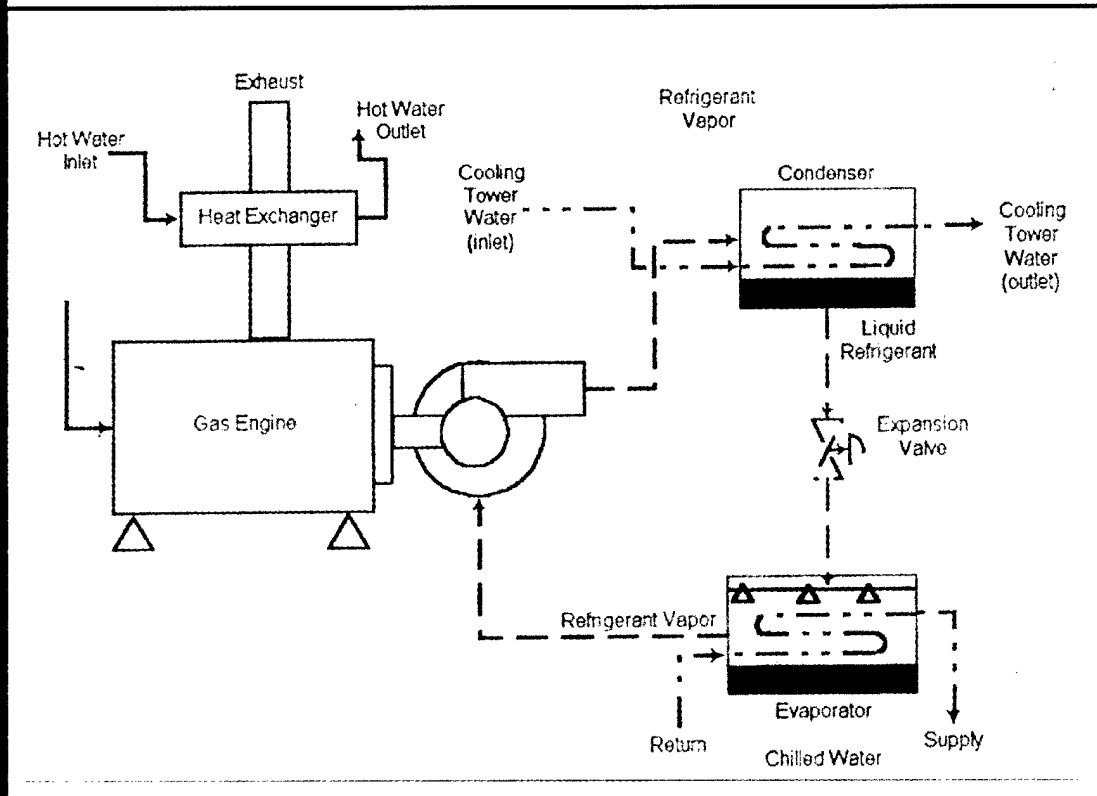



US Army Corps
of Engineers®
Engineer Research and
Development Center

Performance Analysis of Natural Gas Cooling Technology at Warner-Robins AFB, GA

Fiscal Year 2000

William T. Brown, III

August 2001

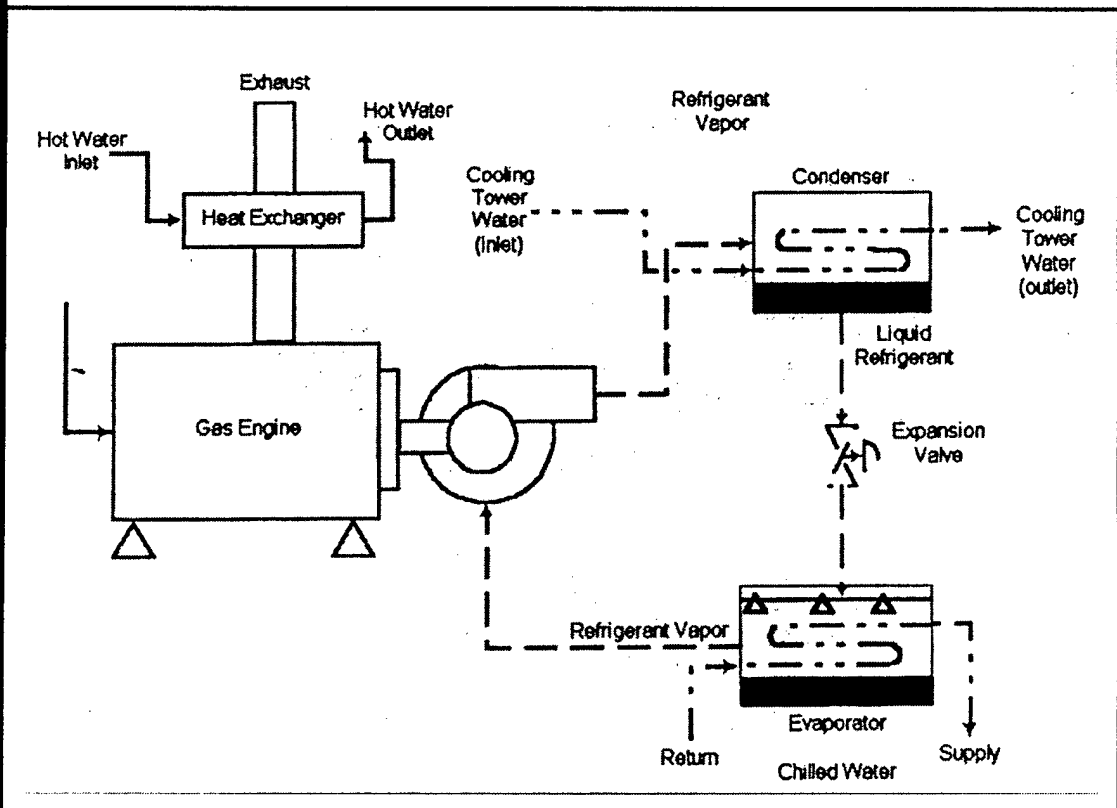

Foreword

This study was conducted for the Headquarters, Air Force Civil Engineer Support Agency (HQ AFCESA) under Military Interdepartmental Purchase Request (MIPR) No. N28FY97000081, Work Unit VR7, "Natural Gas Cooling Technology Program." The technical monitor was Quinn Hart, and the contract monitor was Rich Bauman, AFCESA/CESM.

The work was performed by the Energy Branch (CF-E) of the Facilities Division (CF), Construction Engineering Research Laboratory (CERL). The CERL Principal Investigator was William T. Brown, III. The technical editor was William J. Wolfe, Information Technology Laboratory. Larry M. Windingland is Chief, CEERD-CF-E, and Dr. L. Michael Golish is Chief, CEERD-CF. The associated Technical Director was Gary W. Schanche, CEERD-CV-T. The Acting Director of CERL is Dr. Alan W. Moore.

CERL is an element of the U.S. Army Engineer Research and Development Center (ERDC), U.S. Army Corps of Engineers. The Commander and Executive Director of ERDC is COL John Morris III, EN and the Director of ERDC is Dr. James R. Houston.

DISCLAIMER: The contents of this report are not to be used for advertising, publication, or promotional purposes. Citation of trade names does not constitute an official endorsement or approval of the use of such commercial products. All product names and trademarks cited are the property of their respective owners. The findings of this report are not to be construed as an official Department of the Army position unless so designated by other authorized documents.
DESTROY THIS REPORT WHEN IT IS NO LONGER NEEDED. DO NOT RETURN IT TO THE ORIGINATOR.

Contents

Foreword	2
List of Figures and Tables	4
1 Introduction	5
Background	5
Objective.....	7
Approach	7
Units of Weight and Measure	8
2 Review of Natural Gas Cooling Performance Analysis	9
Data Points Required To Monitor for Performance Analysis	9
Performance Analysis Calculations	9
<i>Chiller Capacity</i>	9
<i>Coefficient of Performance</i>	9
<i>Energy and Demand Cost Analysis Calculations</i>	10
3 Results of Performance Analysis at Warner-Robins AFB, GA	12
Overview.....	12
Comparison of Design and Actual Values	12
Comparison of FY99 and FY00 Cooling Seasons	18
Use of Gas Cooling To Reduce Peak Demand	18
4 Conclusion and Recommendations	20
Conclusion.....	20
Recommendations	21
Bibliography	22
Appendix A: Gas Cooling Analysis	23
Appendix B: Performance Data of Chillers 5 and 6	29
Abbreviations and Acronyms	35
CERL Distribution	36
Report Documentation Page	37

List of Figures and Tables

Figures

1	Gas engine-driven chiller	6
2	Chiller #5 peak loads	14
3	Chiller #6 peak loads	14
4	Example of peak shaving curve	19

Tables

1	Chiller #5 estimated natural gas costs	13
2	Chiller #6 estimated natural gas costs	13
3	Chiller #5 peak load data and COP	13
4	Chiller #6 peak load data and COP	13
5	Chiller #5 ton-hours by ton range	15
6	Chiller #6 ton-hours by ton range	16
7	Cost comparison of old vs. new chillers	17
8	Utility cost and ton-hour comparisons of FY99 and FY00 cooling seasons,	18
9	Energy cost comparisons of FY99 and FY00 cooling seasons	18

1 Introduction

Background

Under the Department of Defense (DOD) Natural Gas Cooling Demonstration Program, four Air Force bases have five natural gas engine-driven chiller systems currently in operation: Davis-Monthan Air Force Base (AFB), AZ, Utah Air National Guard (ANG), UT, Youngstown-Warren Air Reserve Station (ARS), OH, and Warner-Robins AFB, GA. Natural gas-fired cooling technology was chosen for these locations for the same reasons that natural gas cooling has become viable in the commercial market:

- the availability of a new generation of more efficient and reliable gas cooling products
- low natural gas prices (prior to the Fiscal Year 2001 [FY01] winter season)
- the desire to cut energy costs and eliminate electric peak demand charges
- the desire to bring operating costs down
- the responsiveness to environmental calls to switch to cleaner, chlorofluorocarbon (CFC) free technologies
- the need to improve indoor air quality, economically
- the responsiveness to political calls to use an abundant fuel such as natural gas, 95 percent of which is produced domestically.

Currently, high-efficiency gas-fired cooling equipment is readily available for commercial facilities including hotels, office buildings, warehouses, supermarkets, and retail outlets; institutions including hospitals, nursing homes, and schools; and industrial facilities (American Gas Cooling Center, p 7). The three types of natural gas cooling equipment presently on the market are: (1) natural gas engine-driven chillers, (2) absorption cooling systems, and (3) desiccant cooling systems. Of the three types, gas engine-driven chillers have the highest coefficients of performance (COPs), and, in many parts of the United States, have demonstrated the lowest total operating costs.

Engine-driven chillers offer important advantages over electric hermetic and electric open drive chillers. The engine-driven chiller (Figure 1) is comprised of a reciprocating engine coupled through a gearbox to an open drive chiller. The electric motor of a hermetic chiller is totally enclosed within a compressor housing, and is cooled by the refrigerant.

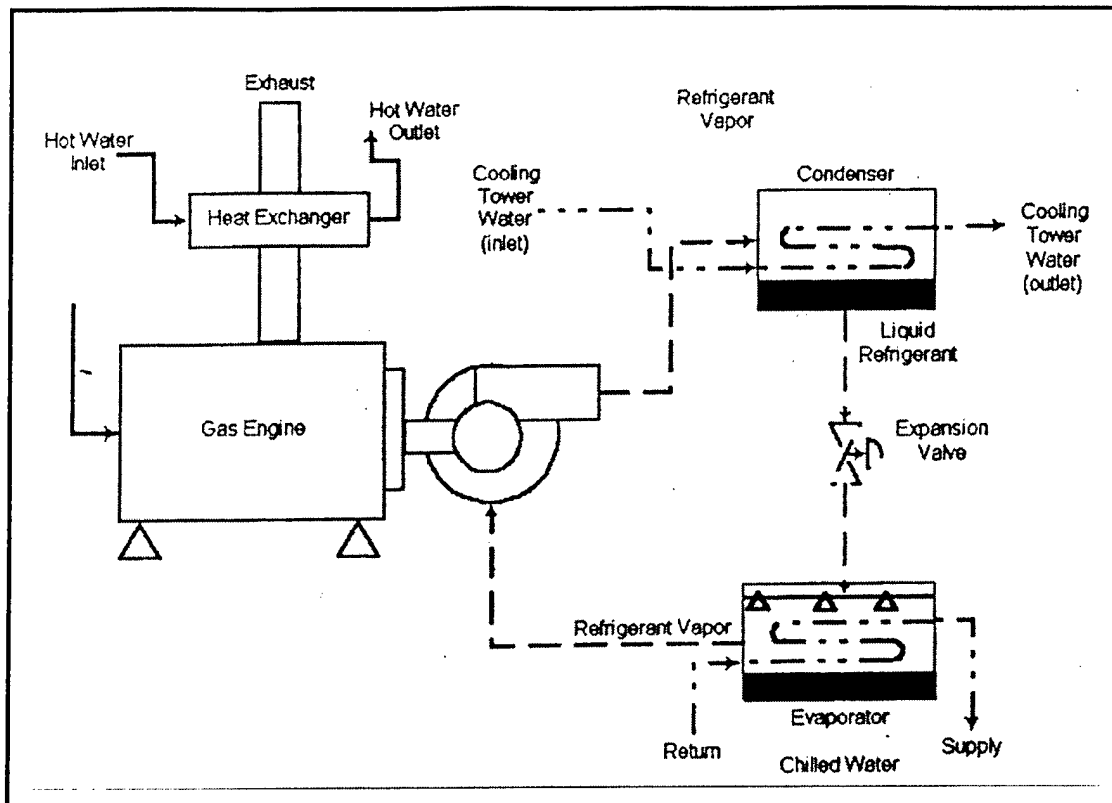

Figure 1. Gas engine-driven chiller.

The additional heat load from the motor, when transferred to the refrigerant, adds 3 to 6 percent in energy consumption. In contrast, with an engine-driven chiller, most of the heat that is generated by the engine to drive the compressor can be recovered from the engine's jacket cooling and exhaust systems. This recoverable engine heat does not have to be discharged to the environment through the chiller's condenser (American Gas Cooling Center 1996, p 3).

Natural gas engine-driven chillers use three major types of compressors:

1. *Centrifugal* compressors, which are available for applications over 400 tons and have been built for systems up to 6,000 tons.
2. *Screw* compressors, which are used for applications from 100 to 4,000 tons.
3. *Reciprocating* compressors, which are typically applied to engine-driven systems requiring less than 200 tons (American Gas Cooling Center 1996, p 4).

Typical COPs of natural gas engine-driven chillers at full load range from 1.2 to 2.0 with no heat recovery, 1.5 to 2.25 with jacket water heat recovery, and from 1.7 to 2.4 with both jacket water and exhaust heat recovery. Heat recovery from the jacket coolant and exhaust gas will boost overall energy utilization (American Gas Cooling Center 1996, p 7).

On the other hand, since the majority of facilities in the United States have electric-driven chillers, personnel are already familiar with the maintenance procedures for electric-driven units. The introduction of gas cooling technology into these facilities will require retraining of personnel or the purchase of maintenance agreements. The costs of these agreements are usually a function of the chiller capacity. (Such agreements are not exclusive to gas engine-driven chillers; they can be also be purchased for electric-driven chillers.)

The maintenance cost of gas engine-driven chillers is somewhat more expensive than that of electric-driven or absorption chillers, or desiccant dehumidifying systems. Annual maintenance costs are based on the annual equivalent full load hours of operation, maintenance costs, and chiller capacity. Maintenance costs of gas engine-driven chillers are approximately 1.5 to 3 times higher than their electric counterparts; the cost of absorption units and desiccant dehumidifying systems falling somewhere in between those values (Pedersen and Brown 1997).

The Construction Engineering Research Laboratory (CERL) was tasked with monitoring the performance of the natural gas technologies at each of the four participating Air Force bases during two consecutive cooling seasons, and with comparing the actual performance data to theoretical values. As part of this monitoring effort, energy and demand cost analyses were performed to compare each natural gas cooling technology with the energy and demand costs of old and new electric chillers.

Objective

The overall objective of this study was to monitor and report on the second year of performance of natural gas cooling technologies at Warner-Robins AFB during the FY00 season. Specific objectives of this part of the monitoring effort were to perform energy and demand cost analyses to compare natural gas cooling technology at each Air Force Base with the energy and demand costs of old and new electric chillers. This study is a follow-up to CERL Technical Report 99/95, *Performance Analysis of Natural Gas Cooling Technology at Air Force Bases: Youngstown-Warren ARS and Warner-Robins AFB, Fiscal Year 1999*.

Approach

CERL representatives were available to supervise and evaluate the acceptance testing results for the installed systems. Monitoring equipment was specified for each facility to record data for either 1 or 2 years. A Hayes compatible modem

was connected to a host computer workstation (at CERL) to enable communication between CERL and the remote computer (at the base). Certain types of communications software (including HyperTerminal, SYNERNET™, METASYS™, ModemPro™, net files, etc.) were installed on the host computer for compatibility with the appropriate remote computer workstation. The phone numbers and login access parameters for each of the remote sites were obtained during the acceptance testing visits. Technical and economic aspects of system performance were monitored remotely. Collected data were analyzed to evaluate the effectiveness of gas equipment at each demonstration site.

Units of Weight and Measure

U.S. standard units of measure are used throughout this report. A table of conversion factors for Standard International (SI) units is provided below.

SI conversion factors			
1 in.	=	2.54 cm	1 cu ft = 0.028 m ³
1 ft	=	0.305 m	1 cu yd = 0.764 m ³
1 yd	=	0.9144 m	1 gal = 3.78 L
1 sq in.	=	6.452 cm ²	1 lb = 0.453 kg
1 sq ft	=	0.093 m ²	°F = (°C x 1.8) + 32
1 sq yd	=	0.836 m ²	1 ton (refrigeration) = 3.516 kW
1 cu in.	=	16.39 cm ³	

2 Review of Natural Gas Cooling Performance Analysis

Data Points Required To Monitor for Performance Analysis

Data points used in monitoring the operation of chillers are best sampled every 15 minutes. The following data points are required to obtain a proper performance analysis for natural gas cooling equipment:

- chilled water supply (CHWS) temperature
- chilled water return (CHWR) temperature
- chilled water (CHW) flow in gallons per minute (gpm)
- natural gas flow rate in standard cubic feet per hour (SCFH).

The CHWS temperature, CHWR temperature, and CHW flow are used to calculate the chiller capacity in tons. Once the tons are calculated, the coefficient of performance (COP) of the chiller can be calculated, given the flow rate and higher heating value (HHV) of natural gas (Brown 1999, p 9).

Performance Analysis Calculations

Chiller Capacity

The capacity of a chiller, in tons, is determined by the following equation:

$$\text{Tons} = \frac{(\text{CHW Flow}) * (\text{CHWR Temp} - \text{CHWS Temp})}{24} \quad \text{Eq. 1}$$

where CHWR Temp and CHWS Temp are expressed in degrees Fahrenheit (°F), and CHW Flow in gpm.

Coefficient of Performance

The COP of the chiller is the standard calculation for rating the performance of cooling equipment. COPs for engine-driven chillers can be determined using the following equation:

$$\text{COP} = \frac{\text{Tons} * 12,000 \text{ BTU/ton-hr}}{\text{Natural Gas Flow (in SCFH)} * \text{HHV}} \quad \text{Eq. 2}$$

where HHV is determined from a base gas bill.

Energy and Demand Cost Analysis Calculations

Data were collected from each facility to indicate the peak tonnage produced by the engine-driven chillers each month and the number of hours at various average loads during the entire monitoring period. Peak monthly tonnage information is necessary to estimate the demand charges that would result if electric motor-driven chillers are used instead of natural gas engine-driven chillers. Load duration information is required to estimate energy costs. The monthly electrical demand cost would be computed as follows.

If no ratchet is applied:

$$\text{Demand Cost} = \left(\frac{\text{Tons}_{\text{actual}}}{\text{Tons}_{\text{design}}} \right) * \left(\text{Tons}_{\text{actual}} * \left(\frac{\text{kW}}{\text{ton}} \right)_{\text{new}} \right)_{\text{max}} * \text{Demand Charge} \quad \text{Eq. 3}$$

where:

$\text{Tons}_{\text{actual}}$ = Monthly peak load

$\text{Tons}_{\text{design}}$ = Full-load capacity of the gas engine-driven chiller

$(\text{kW}/\text{ton})_{\text{new}}$ = Efficiency of new electric chiller at full load

$(\text{Tons}_{\text{actual}} * (\text{kW}/\text{ton})_{\text{new}})_{\text{max}}$ = Maximum product of monthly peak load and efficiency of new electric chiller over selected monitoring period.

If a ratchet is applied, and the load ratio ($\text{Tons}_{\text{actual}}/\text{Tons}_{\text{design}}$) is greater than the ratchet percentage:

$$\text{Demand Cost} = \text{Tons}_{\text{actual}} * \left(\frac{\text{kW}}{\text{ton}} \right)_{\text{new}} * \text{Demand Charge} \quad \text{Eq. 4}$$

If a ratchet is applied, and the load ratio ($\text{Tons}_{\text{actual}}/\text{Tons}_{\text{design}}$) is less than the ratchet percentage:

$$\text{Demand Cost} = \left(\frac{\% \text{ Ratchet}}{100} \right) * \left(\frac{\text{kW}}{\text{ton}} \right)_{\text{new}} * \text{Tons}_{\text{design}} * \text{Demand Charge} \quad \text{Eq. 5}$$

Load duration information includes the number of hours a chiller operates within specified ton ranges. Depending on how the ton ranges are grouped, the ton-hours would be computed as follows:

$$\text{Ton-Hours} = \sum_{i=1}^n (\text{Avg Ton Range} * \text{Hours in Ton Range}) \quad \text{Eq. 6}$$

The energy cost would then be computed by the following equation:

$$\text{Energy Cost} = \left(\frac{\text{kW}}{\text{ton}} \right)_{\text{new}} * \text{Ton-Hours} * \text{Energy Charge} \quad \text{Eq. 7}$$

3 Results of Performance Analysis at Warner-Robins AFB, GA

Overview

Warner-Robins AFB currently has two, 1310-ton, R-134A York-Caterpillar gas engine-driven water-cooled chillers in operation. The chillers (Chiller #5 and Chiller #6, respectively) are located at the central energy plant (Building 177). Commissioning of the chillers was completed in July 1999. Data points monitored during its operation are collected using the Johnson Controls METASYS™ Person Machine Interface (PMI) workstation system. The chiller has the following design parameters: 1.83 full-load COP, 2.27 COP at 982.5 tons, 2.53 COP at 655 tons, 1.88 COP at 327.5 tons, 43 °F chilled water supply temperature, 53 °F chilled water return temperature, and 3144 gpm of chilled water flow. The HHV is 1010 BTU/SCF. The Warner-Robins AFB POC is Ray Tuten, tel.: (912) 926-3533, ext. 136.

Comparison of Design and Actual Values

Data for the two, 1310-ton, gas engine-driven chillers were acquired for the months of May through August 2000. Based on the full-load COP at 1310 tons and part-load COPs at 327.5 tons, 655 tons, and 982.5 tons, the natural gas flow estimates for different chiller capacities were interpolated for May, June, July, and August 2000 for the two chillers (Tables 1 and 2).

Information from the base indicates an energy charge of \$0.0348/kWh for the month of May 2000, an energy charge of \$0.0378 /kWh for the month of June 2000, an energy charge of \$0.0369/kWh for the month of July 2000, and an energy charge of \$0.0380/kWh for the month of August 2000 (due to real-time pricing). There are no demand charges applied at the base. Tables 3 and 4 show the demand charges for Chillers #5 and #6 to be zero. Figures 2 and 3 show the peak tonnages produced by the engine-driven chillers each month. Tables 5 and 6 show the results of the ton-hour calculations for the entire monitoring period for the chiller.

Table 1. Chiller #5 estimated natural gas costs.

	Estimated NG Flow	NG Unit Cost (\$/MBtu)	Estimated NG Cost
May 2000	124	\$3.0495	\$ 378
June 2000	590	\$3.2376	\$1910
July 2000	0	\$4.7128	\$ 0
August 2000	0	\$4.6999	\$ 0
Total			\$2288

Table 2. Chiller #6 estimated natural gas costs.

	Estimated NG Flow	NG Unit Cost (\$/MBtu)	Estimated NG Cost
May 2000	518	\$3.0495	\$1580
June 2000	551	\$3.2376	\$1784
July 2000	20	\$4.7128	\$94
August 2000	207	\$4.6999	\$973
Total			\$4431

Table 3. Chiller #5 peak load data and COP.

Month	Peak Load	COP	When Peak Occurred		Demand Cost
			Date	Time	
May 2000	1283.2	1.83	5/26/00	9:30	\$ 0.00
June 2000	1308.45	1.81	6/8/00	12:30	\$ 0.00
July 2000	0.00	N/A	N/A	N/A	\$ 0.00
August 2000	0.00	N/A	N/A	N/A	\$ 0.00

Table 4. Chiller #6 peak load data and COP.

Month	Peak Load	COP	When Peak Occurred		Demand Cost
			Date	Time	
May 2000	1288.7	1.83	5/25/00	16:30	\$ 0.00
June 2000	1305.43	1.82	6/12/00	0:00	\$ 0.00
July 2000	3.18	0.03	7/2/00	15:00	\$ 0.00
August 2000	1279.33	1.84	8/10/00	15:30	\$ 0.00

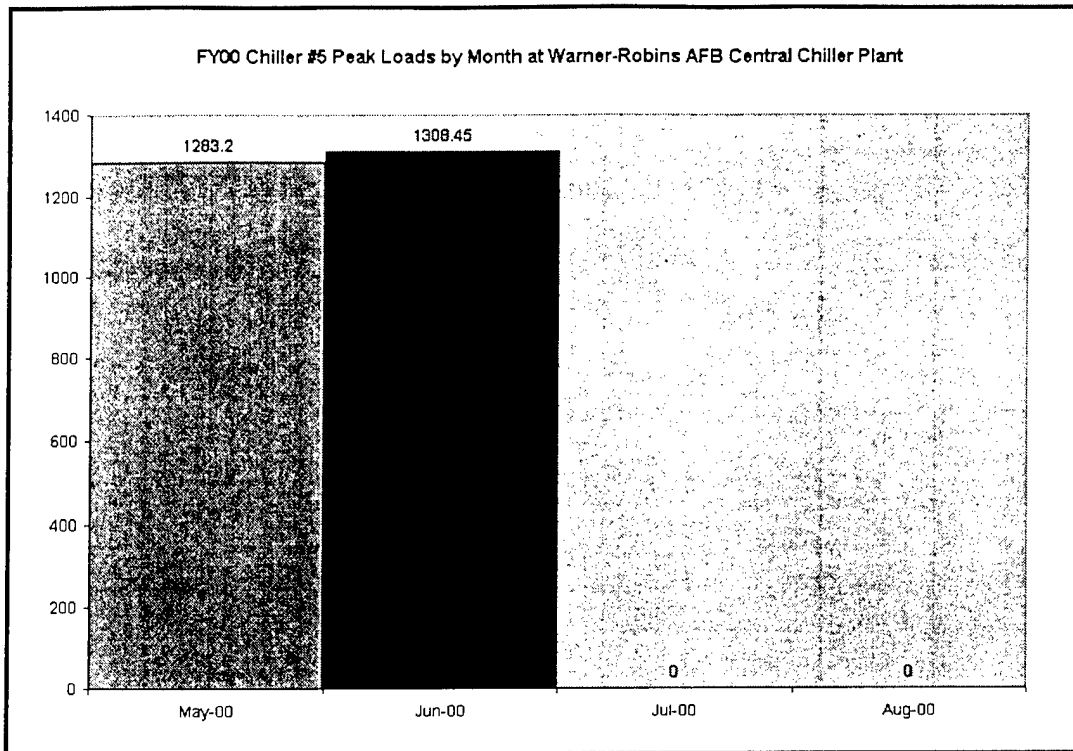

Figure 2. Chiller #5 peak loads.

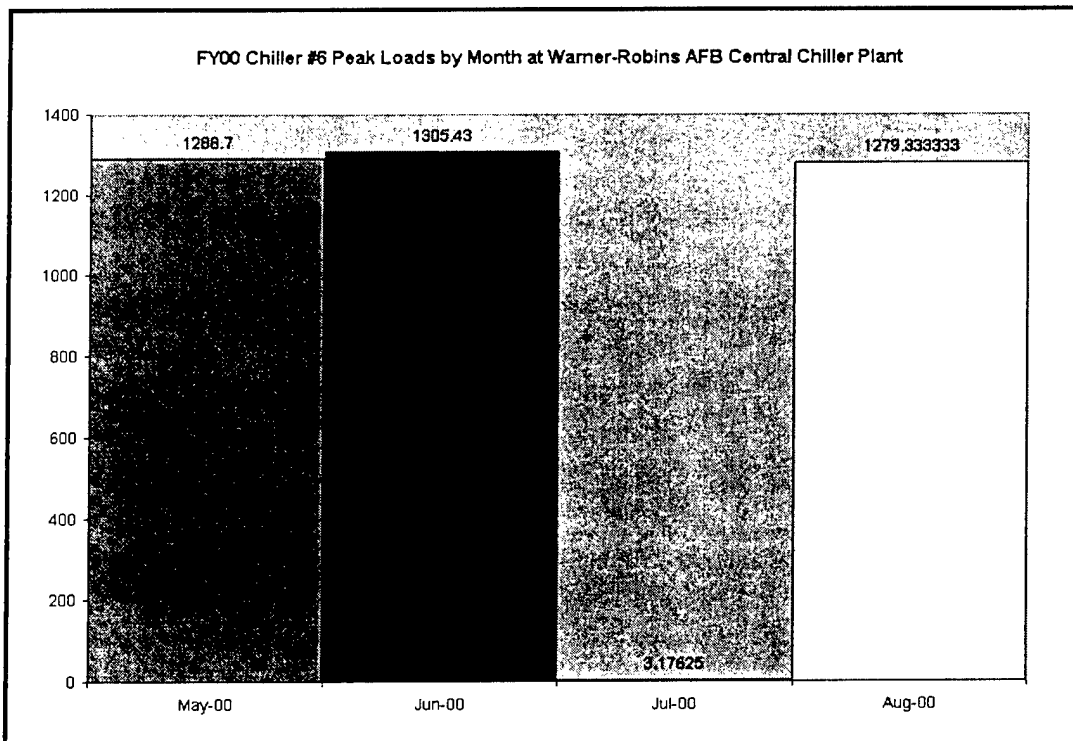

Figure 3. Chiller #6 peak loads.

Table 5. Chiller #5 ton-hours by ton range.

Ton Range	May 2000		June 2000		July 2000		August 2000	
	Hours	Ton-Hours	Hours	Ton-Hours	Hours	Ton-Hours	Hours	Ton-Hours
16.375	6.00	98.25	0.50	8.19	0.00	0.00	0.00	0.00
49.125	0.00	0.00	0.00	0.00	0.00	0.00	0.00	0.00
81.875	0.50	40.94	0.50	40.94	0.00	0.00	0.00	0.00
114.625	0.00	0.00	0.00	0.00	0.00	0.00	0.00	0.00
147.375	0.00	0.00	0.00	0.00	0.00	0.00	0.00	0.00
180.125	0.00	0.00	0.50	90.06	0.00	0.00	0.00	0.00
212.875	0.50	106.44	0.00	0.00	0.00	0.00	0.00	0.00
245.625	0.50	122.81	0.00	0.00	0.00	0.00	0.00	0.00
278.375	0.00	0.00	0.00	0.00	0.00	0.00	0.00	0.00
311.125	0.00	0.00	0.00	0.00	0.00	0.00	0.00	0.00
343.875	0.00	0.00	0.00	0.00	0.00	0.00	0.00	0.00
376.625	0.00	0.00	0.00	0.00	0.00	0.00	0.00	0.00
409.375	0.50	204.69	0.00	0.00	0.00	0.00	0.00	0.00
442.125	0.00	0.00	0.00	0.00	0.00	0.00	0.00	0.00
474.875	0.00	0.00	0.00	0.00	0.00	0.00	0.00	0.00
507.625	0.00	0.00	0.00	0.00	0.00	0.00	0.00	0.00
540.375	0.00	0.00	0.00	0.00	0.00	0.00	0.00	0.00
573.125	0.00	0.00	0.00	0.00	0.00	0.00	0.00	0.00
605.875	0.00	0.00	0.00	0.00	0.00	0.00	0.00	0.00
638.625	0.00	0.00	0.00	0.00	0.00	0.00	0.00	0.00
671.375	0.00	0.00	0.50	335.69	0.00	0.00	0.00	0.00
704.125	0.00	0.00	0.00	0.00	0.00	0.00	0.00	0.00
736.875	0.00	0.00	0.00	0.00	0.00	0.00	0.00	0.00
769.625	0.00	0.00	0.00	0.00	0.00	0.00	0.00	0.00
802.375	0.00	0.00	0.00	0.00	0.00	0.00	0.00	0.00
835.125	0.00	0.00	0.00	0.00	0.00	0.00	0.00	0.00
867.875	0.00	0.00	0.00	0.00	0.00	0.00	0.00	0.00
900.625	0.00	0.00	2.00	1,801.25	0.00	0.00	0.00	0.00
933.375	0.00	0.00	6.00	5,600.25	0.00	0.00	0.00	0.00
966.125	0.00	0.00	5.50	5,313.69	0.00	0.00	0.00	0.00
998.875	0.00	0.00	5.50	5,493.81	0.00	0.00	0.00	0.00
1031.625	0.50	515.81	5.50	5,673.94	0.00	0.00	0.00	0.00
1064.375	1.00	1,064.38	12.50	13,304.69	0.00	0.00	0.00	0.00
1097.125	2.50	2,742.81	17.50	19,199.69	0.00	0.00	0.00	0.00
1129.875	4.50	5,084.44	14.50	16,383.19	0.00	0.00	0.00	0.00
1162.625	2.00	2,325.25	8.00	9,301.00	0.00	0.00	0.00	0.00
1195.375	1.50	1,793.06	6.00	7,172.25	0.00	0.00	0.00	0.00
1228.125	1.50	1,842.19	4.50	5,526.56	0.00	0.00	0.00	0.00
1260.875	2.50	3,152.19	4.00	5,043.50	0.00	0.00	0.00	0.00
1293.625	0.50	646.81	3.00	3,880.88	0.00	0.00	0.00	0.00
Total	24.5	19,740.07	96.50	104,169.58	0.00	0.00	0.00	0.00

Table 6. Chiller #6 ton-hours by ton range.

Ton Range	May 00		June 2000		July 2000		August 2000	
	Hours	Ton-Hours	Hours	Ton-Hours	Hours	Ton-Hours	Hours	Ton-Hours
16.375	36.50	597.69	115.50	1,891.31	18.00	294.75	0.50	8.19
49.125	0.00	0.00	0.00	0.00	0.00	0.00	0.00	0.00
81.875	0.00	0.00	0.00	0.00	0.00	0.00	0.00	0.00
114.625	0.00	0.00	0.50	57.31	0.00	0.00	0.00	0.00
147.375	0.00	0.00	0.00	0.00	0.00	0.00	0.00	0.00
180.125	0.00	0.00	0.00	0.00	0.00	0.00	0.00	0.00
212.875	0.00	0.00	0.00	0.00	0.00	0.00	0.00	0.00
245.625	0.00	0.00	0.00	0.00	0.00	0.00	0.00	0.00
278.375	0.00	0.00	0.00	0.00	0.00	0.00	0.00	0.00
311.125	0.00	0.00	0.00	0.00	0.00	0.00	0.00	0.00
343.875	0.00	0.00	0.00	0.00	0.00	0.00	0.00	0.00
376.625	0.00	0.00	0.00	0.00	0.00	0.00	0.00	0.00
409.375	0.00	0.00	0.00	0.00	0.00	0.00	0.00	0.00
442.125	0.00	0.00	0.00	0.00	0.00	0.00	0.00	0.00
474.875	0.00	0.00	0.00	0.00	0.00	0.00	0.00	0.00
507.625	0.00	0.00	0.00	0.00	0.00	0.00	0.00	0.00
540.375	0.00	0.00	0.00	0.00	0.00	0.00	0.00	0.00
573.125	0.00	0.00	0.50	286.56	0.00	0.00	0.00	0.00
605.875	0.00	0.00	0.00	0.00	0.00	0.00	0.00	0.00
638.625	0.00	0.00	0.00	0.00	0.00	0.00	0.00	0.00
671.375	0.50	335.69	0.00	0.00	0.00	0.00	0.00	0.00
704.125	0.00	0.00	0.00	0.00	0.00	0.00	0.00	0.00
736.875	1.00	736.88	1.00	736.88	0.00	0.00	0.00	0.00
769.625	0.00	0.00	2.50	1,924.06	0.00	0.00	0.00	0.00
802.375	4.00	3,209.50	1.50	1,203.56	0.00	0.00	0.00	0.00
835.125	5.50	4,593.19	8.50	7,098.56	0.00	0.00	0.00	0.00
867.875	5.50	4,773.31	12.50	10,848.44	0.00	0.00	0.00	0.00
900.625	5.00	4,503.13	10.00	9,006.25	0.00	0.00	0.00	0.00
933.375	7.50	7,000.31	13.00	12,133.88	0.00	0.00	0.00	0.00
966.125	7.00	6,762.88	9.00	8,695.13	0.00	0.00	0.00	0.00
998.875	8.50	8,490.44	19.50	19,478.06	0.00	0.00	1.50	1,498.31
1031.625	9.50	9,800.44	15.00	15,474.38	0.00	0.00	1.50	1,547.44
1064.375	3.50	3,725.31	10.50	11,175.94	0.00	0.00	2.50	2,660.94
1097.125	6.00	6,582.75	8.00	8,777.00	0.00	0.00	5.00	5,485.63
1129.875	7.00	7,909.13	8.00	9,039.00	0.00	0.00	7.00	7,909.13
1162.625	2.50	2,906.56	7.00	8,138.38	0.00	0.00	6.50	7,557.06
1195.375	3.50	4,183.81	8.50	10,160.69	0.00	0.00	1.50	1,793.06
1228.125	3.50	4,298.44	4.50	5,526.56	0.00	0.00	2.00	2,456.25
1260.875	4.00	5,043.50	6.00	7,565.25	0.00	0.00	2.50	3,152.19
1293.625	1.00	1,293.63	3.00	3,880.88	0.00	0.00	0.50	646.81
Total	121.50	86,746.59	264.50	153,098.08	18.00	294.75	31.00	34,715.01

Using the full load efficiency of 0.55 kW/ton and the appropriate energy charges, the energy costs are:

For Chiller #5:

$$\begin{aligned} \text{Energy cost} &= 0.55 \text{ kW/ton} \times (19,740.07 \text{ ton-hrs} \times \$0.0348/\text{kWh} \\ &\quad + 104,169.58 \text{ ton-hrs} \times \$0.0378/\text{kWh} + 0 \text{ ton-hrs} \times \$0.0369/\text{kWh} \\ &\quad + 0 \text{ ton-hrs} \times \$0.0380/\text{kWh}) = \$2,544 \end{aligned}$$

For Chiller #6:

$$\begin{aligned} \text{Energy cost} &= 0.55 \text{ kW/ton} \times (86,746.59 \text{ ton-hrs} \times \$0.0348/\text{kWh} \\ &\quad + 153,098.08 \text{ ton-hrs} \times \$0.0378/\text{kWh} + 294.75 \text{ ton-hrs} \times \$0.0369/\text{kWh} \\ &\quad + 34,715.01 \text{ ton-hrs} \times \$0.0380/\text{kWh}) = \$5,575 \end{aligned}$$

The total electrical cost for each new electric chiller for the period would be:

$$\begin{aligned} \text{Chiller \#5:} &\quad \$2,544 + 0 = \$2,544 \\ \text{Chiller \#6:} &\quad \$5,575 + 0 = \$5,575 \end{aligned}$$

The efficiency of the old electric chiller at the central plant was 0.65 kW/ton. Since there are no demand charges applied, the demand costs would then be zero, regardless of load.

The electrical energy cost would then be:

For Chiller #5:

$$\begin{aligned} \text{Energy cost} &= 0.65 \text{ kW/ton} \times (19,740.07 \text{ ton-hrs} \times \$0.0348/\text{kWh} \\ &\quad + 104,169.58 \text{ ton-hrs} \times \$0.0378/\text{kWh} + 0 \text{ ton-hrs} \times \$0.0369/\text{kWh} \\ &\quad + 0 \text{ ton-hrs} \times \$0.0380/\text{kWh}) = \$3,006 \end{aligned}$$

For Chiller #6:

$$\begin{aligned} \text{Energy cost} &= 0.65 \text{ kW/ton} \times (86,746.59 \text{ ton-hrs} \times \$0.0348/\text{kWh} \\ &\quad + 153,098.08 \text{ ton-hrs} \times \$0.0378/\text{kWh} + 294.75 \text{ ton-hrs} \times \$0.0369/\text{kWh} \\ &\quad + 34,715.01 \text{ ton-hrs} \times \$0.0380/\text{kWh}) = \$6,588 \end{aligned}$$

If the old electric chillers were used, the total electrical cost would then be:

$$\begin{aligned} \text{Chiller \#5:} &\quad \$3,006 + 0 = \$3,006 \\ \text{Chiller \#6:} &\quad \$6,588 + 0 = \$6,588 \end{aligned}$$

Table 7 summarizes the cost comparison for Warner-Robins AFB.

Table 7. Cost comparison of old vs. new chillers.

Chiller Type	Chiller #5	Chiller #6
Old electric chiller	\$3,006	\$6,588
New electric chiller	\$2,544	\$5,575
New gas chiller	\$2,288 (estimate)	\$4,431 (estimate)

Comparison of FY99 and FY00 Cooling Seasons

Table 8 shows utility cost and ton-hour comparisons between the FY99 and FY00 cooling seasons at Warner-Robins AFB. Table 9 shows energy cost comparisons between the FY99 and FY00 cooling seasons.

At the monitored Air Force base, the costs for the natural gas used by the engine-driven chillers were lower than electrical costs used by old and new electric chillers, resulting in an energy cost savings (Tables 7 and 9).

Use of Gas Cooling To Reduce Peak Demand

The engine-driven chiller in a hybrid plant can often be used to reduce or shave the building's electric demand during on-peak hours. One or more electric chillers supply the base cooling load or are shut off during on-peak hours. The savings in peak demand charged by the electric utility can often provide substantial cost savings. Gas cooling can be installed when a significant expansion of a facility is planned, thereby satisfying the need for additional capacity while providing the flexibility to dispatch gas cooling during periods of high electric demand. Figure 4 shows an example of peak cooling.

Table 8. Utility cost and ton-hour comparisons of FY99 and FY00 cooling seasons.

Month and Year	Energy, \$/kWh	Natural Gas, \$/MBtu	FY99 Ton-Hours		FY00 Ton-Hours	
			Chiller #5	Chiller #6	Chiller #5	Chiller #6
July 1999	\$ 0.0355	\$ 2.47	54,995.46	10,455.45		
August 1999	\$ 0.0493	\$ 2.52	56,018.91	309,250.10		
May 2000	\$ 0.0348	\$ 3.05			19,740.07	86,746.59
June 2000	\$ 0.0378	\$ 3.24			104,169.58	153,098.08
July 2000	\$ 0.0369	\$ 4.71			0.00	294.75
August 2000	\$ 0.0380	\$ 4.70			0.00	34,715.01

Table 9. Energy cost comparisons of FY99 and FY00 cooling seasons.

Chiller Type	Energy Cost (FY99)		Energy Cost (FY00)	
	Monitoring period: Jul – Aug 99		Monitoring period: May – Aug 00	
	Chiller #5	Chiller #6	Chiller #5	Chiller #6
Old electric chiller	\$ 3,066	\$ 10,155	\$ 3,006	\$ 6,588
New electric chiller	\$ 2,594	\$ 8,593	\$ 2,544	\$ 5,575
New gas chiller	\$ 1,522 (estimate)	\$ 4,474 (estimate)	\$ 2,288 (estimate)	\$ 4,431 (estimate)

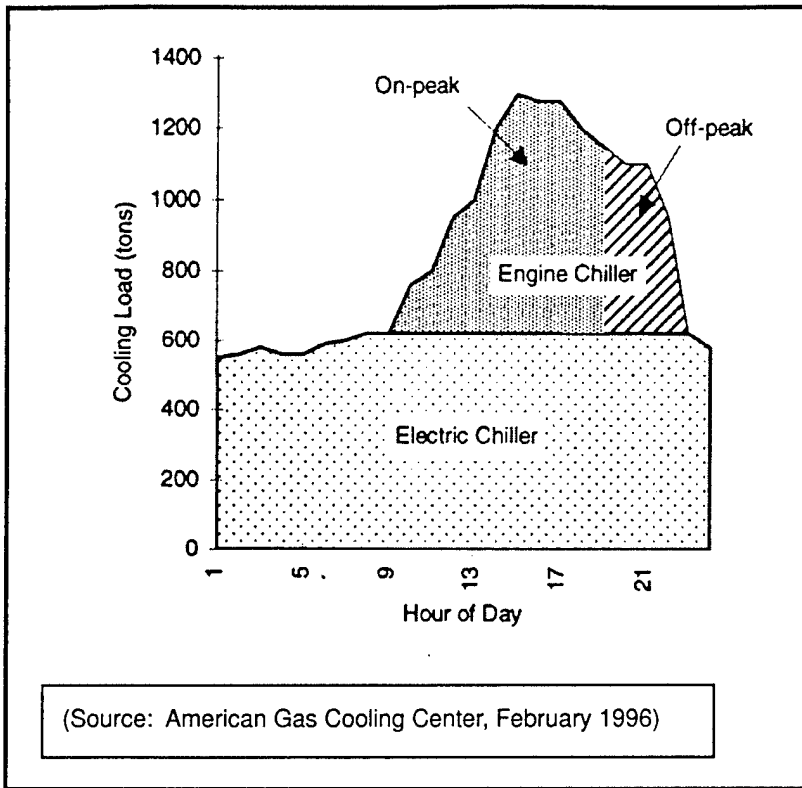

Figure 4. Example of peak shaving curve.

4 Conclusion and Recommendations

Conclusion

This study provided performance-monitoring data for natural gas cooling technologies operating at Warner-Robins AFB, GA, based on the FY00 cooling season. Both theoretical and actual performance values for each natural gas cooling technology were compared for validation of their operation. The technical and economical aspects of operable natural gas cooling equipment performance were monitored on successful commissioning and functional performance testing acceptability. Energy and demand cost analyses were performed to compare each natural gas cooling technology with the energy and demand costs of old and new electric chillers.

This study concludes that gas cooling technologies, such as gas engine-driven chillers, can offer installations and bases environmental and economic benefits (Table 7 [p 17] and Table 9 [p 18]). The environmental benefit stems from the fact that engine-driven chillers typically use hydrochlorofluorocarbons (HCFCs) or hydrofluorocarbons (HFCs) with low or zero ozone-depleting potential. The economic benefits of engine-driven chillers can vary since gas chiller equipment costs are higher than conventional electric-driven vapor-compression equipment.

To reduce peak electric demand and increase summer gas sales, many gas and electric utilities offer rebates for unit installations and bases on a per-ton basis. Sometimes these rebates alone make up the equipment cost differential. Some gas utilities also offer reduced rates to facilities using gas for cooling purposes. Some applications reduce costs in other areas by providing energy to produce domestic hot water and/or boiler makeup water. Use of these applications increases the system's overall cost effectiveness.

Chillers are rarely operated at their rated capacities more than a few hundred hours per year. Two or more smaller chillers may result in more efficient operation, lower life-cycle costs, and lower operating costs. In some cases, a hybrid chiller plant makes economic sense. A hybrid plant is a combination of electric- and gas engine-driven chillers and sometimes leads to lower life-cycle and operation costs. The operation of the plants would be cycled to take advantage of the off-demand portion of the electric utility bill. The installation of more than one

chiller will also allow for continued service during scheduled and unscheduled maintenance (Pedersen et al. 1996).

Recommendations

It is recommended that data points for CHWS and CHWR temperatures and chilled water flow be documented every 15 minutes. To improve performance and acquire a more accurate savings, it is also recommended that each Air Force facility under the Natural Gas Cooling Technology Program provide minute-by-minute readings of natural gas flow, as opposed to instantaneous values every 15 minutes.

In cases where the remote operator is unavailable to download the trend data on a daily basis due to leave or temporary duty (TDY), it is recommended that the proper communications or datalogger software be used to automatically transfer data to the remote operator's computer workstation. Automatic data transfer should occur in the early mornings every 24 hours via modem from the installation's host operator workstation to the remote monitoring site (including weekends and holidays). Without automatic data transfer, the historical trend data provided by the host workstation may not be stored permanently. If the remote operator does not download the trend data in time, valuable data may be lost. Such missing data could compromise the accuracy of performance and cost results.

Finally, it is recommended that CERL representatives monitor any facilities that will complete successful commissioning and acceptance testing of natural gas cooling equipment for performance to document the actual savings incurred.

Bibliography

- American Gas Cooling Center, *Applications Engineering Manual for Engine Driven Chillers* (Arlington, VA, February 1996), p 20.
- American Gas Cooling Center, *Natural Gas Cooling Equipment Guide*, 4th ed. (Arlington, VA, April 1996).
- Brown, William T., III, *Performance Analysis of Natural Gas Cooling Technology at Air Force Bases*, Technical Report (TR) 99/14/ADA359312 (Construction Engineering Research Laboratory [CERL], December 1998).
- Brown, William T III, *Performance Analysis of Natural Gas Cooling Technology at Air Force Bases: Youngstown-Warren ARS and Warner-Robins AFB, Fiscal Year 1999*, TR 99/95/ADA371555 (CERL, December 1999).
- Caponegro, Michael, William Brown, and Timothy Pedersen, *Advanced Gas Cooling Study for the Hospital at Davis-Monthan AFB, AZ*, TR 99/24/ADA361005 (CERL, January 1999).
- Cler, Gerald, *Evaluating Gas-Fueled Cooling Technologies for Applications at Army Installations*, TR 96/14/ADA304704 (CERL, November 1995).
- Pedersen, Timothy, Michael Brewer, Daryl Matsui, Richard Rundus, Thomas Durbin, Christopher Dilks, Michael Caponegro, and Ralph Moshage, *Gas-Fueled Cooling Technologies at DOD Fixed Facilities*, TR 96/62/ADA309231 (CERL, April 1996).
- Pedersen, Timothy, and William Brown, *Advanced Gas Cooling Technology Demonstration Program at Air Force Installations, Fiscal Year 1996*, TR 97/106/ADA327941 (CERL, July 1997).
- Sohn, Chang W., William Brown, Richard Rundus, Timothy Pedersen, Thomas Durbin, Michael Caponegro, and Daryl Matsui, *Natural Gas Cooling in DOD Facilities*, TR 97/125/ADA332974 (CERL, August 1997).

Appendix A: Gas Cooling Analysis

Gas Cooling Analysis		Input Data Sheet																																																																		
< To Print Tables - ctrl t, To Print Charts - ctrl c >																																																																				
<p>Notice to Users:</p> <p>This spreadsheet is designed to assist the user in performing a preliminary feasibility analysis comparing electric, absorption, and engine driven chillers. Calculations are based on user provided data and results rely on this input data. This spreadsheet calculates the approximate equipment & installation costs along with the annual operating and maintenance costs. Additionally, simple payback is calculated, based on the incremental additional cost of the alternative cooling technology and the annual operating cost savings. Part of the development of this tool was supported by the Strategic Environmental Research and Development Program (SERDP)</p>																																																																				
<p>Input Section Fill in all shaded boxes</p> <p>Enter Facility Name: <input style="width: 90%;" type="text" value="Warner-Robins AFB, CEP"/></p> <p>Analyst: <input style="width: 90%;" type="text" value="WTB 10/12/2000"/></p>																																																																				
<p>Cooling Load Building Type: <input style="width: 80%;" type="text" value="Central Plant (Chiller #6)"/></p> <table style="width: 100%; border-collapse: collapse;"> <tr> <td style="width: 40%;">Peak Load:</td> <td style="width: 15%; text-align: center;"><input style="width: 80%;" type="text" value="1,310"/></td> <td style="width: 45%;">tons</td> </tr> <tr> <td>Annual Hours of Operation:</td> <td style="text-align: center;"><input style="width: 80%;" type="text" value="435"/></td> <td>hours</td> </tr> <tr> <td>Equivalent Full Load Hour Percentage:</td> <td style="text-align: center;"><input style="width: 80%;" type="text" value="48"/></td> <td>% (for most air conditioning applications, EFLH = 50 %)</td> </tr> <tr> <td>Cooling Peak Load/Ave Load Ratio:</td> <td colspan="2" style="text-align: center;">41.86</td> </tr> </table> <table style="width: 100%; border-collapse: collapse;"> <thead> <tr> <th style="width: 30%;">Chiller Efficiencies:</th> <th style="width: 10%;">Peak</th> <th style="width: 10%;">IPLV</th> <th style="width: 15%;">COP Ratio</th> <th style="width: 35%;">Parasitic Electrical Requirements:</th> </tr> </thead> <tbody> <tr> <td>Existing Electric (kW/ton)</td> <td style="text-align: center;"><input style="width: 80%;" type="text" value="0.65"/></td> <td style="text-align: center;"><input style="width: 80%;" type="text" value="0.65"/></td> <td rowspan="4" style="vertical-align: top;"> 1.18 New/Old Elec 0.16 Abs/New Elc 0.29 Gas/New Elc </td> <td>Existing Elect <input style="width: 80%;" type="text" value="0.239"/> kW/tn</td> </tr> <tr> <td>New Electric (kW/ton)</td> <td style="text-align: center;"><input style="width: 80%;" type="text" value="0.55"/></td> <td style="text-align: center;"><input style="width: 80%;" type="text" value="0.55"/></td> <td>New Elect <input style="width: 80%;" type="text" value="0.239"/> kW/tn</td> </tr> <tr> <td>Absorption (COP)</td> <td style="text-align: center;"><input style="width: 80%;" type="text" value="1.02"/></td> <td style="text-align: center;"><input style="width: 80%;" type="text" value="1.02"/></td> <td>Absorption <input style="width: 80%;" type="text" value="0.315"/> kW/tn</td> </tr> <tr> <td>Engine Driven (COP)</td> <td style="text-align: center;"><input style="width: 80%;" type="text" value="1.83"/></td> <td style="text-align: center;"><input style="width: 80%;" type="text" value="2.77"/></td> <td>Eng Driven <input style="width: 80%;" type="text" value="0.269"/> kW/tn</td> </tr> </tbody> </table> <table style="width: 100%; border-collapse: collapse;"> <thead> <tr> <th colspan="4" style="text-align: left;">Monthly Peak Cooling Load (% of peak)</th> </tr> </thead> <tbody> <tr> <td style="width: 25%;">Jan</td> <td style="width: 25%; text-align: center;"><input style="width: 80%;" type="text" value="0"/></td> <td style="width: 25%;">Feb</td> <td style="width: 25%; text-align: center;"><input style="width: 80%;" type="text" value="0"/></td> </tr> <tr> <td>May</td> <td style="text-align: center;"><input style="width: 80%;" type="text" value="98"/></td> <td>Jun</td> <td style="text-align: center;"><input style="width: 80%;" type="text" value="100"/></td> </tr> <tr> <td>Sep</td> <td style="text-align: center;"><input style="width: 80%;" type="text" value="0"/></td> <td>Oct</td> <td style="text-align: center;"><input style="width: 80%;" type="text" value="0"/></td> </tr> <tr> <td>Mar</td> <td style="text-align: center;"><input style="width: 80%;" type="text" value="0"/></td> <td>Nov</td> <td style="text-align: center;"><input style="width: 80%;" type="text" value="0"/></td> </tr> <tr> <td>Apr</td> <td style="text-align: center;"><input style="width: 80%;" type="text" value="0"/></td> <td>Dec</td> <td style="text-align: center;"><input style="width: 80%;" type="text" value="0"/></td> </tr> <tr> <td>Jul</td> <td style="text-align: center;"><input style="width: 80%;" type="text" value="0"/></td> <td></td> <td style="text-align: center;"><input style="width: 80%;" type="text" value="98"/></td> </tr> <tr> <td></td> <td></td> <td></td> <td style="text-align: center;"><input style="width: 80%;" type="text" value="0"/></td> </tr> </tbody> </table> <p style="font-size: small; margin-top: 10px;"> Notes: 1 therm = 100,000 Btu, k = 1000 (kW = 1000 W); M = 1,000,000 (MBtu = 1,000,000 Btu) When evaluating steam fired absorption chillers, be sure to account for boiler efficiency when entering chiller COP. This is not done automatically. </p>			Peak Load:	<input style="width: 80%;" type="text" value="1,310"/>	tons	Annual Hours of Operation:	<input style="width: 80%;" type="text" value="435"/>	hours	Equivalent Full Load Hour Percentage:	<input style="width: 80%;" type="text" value="48"/>	% (for most air conditioning applications, EFLH = 50 %)	Cooling Peak Load/Ave Load Ratio:	41.86		Chiller Efficiencies:	Peak	IPLV	COP Ratio	Parasitic Electrical Requirements:	Existing Electric (kW/ton)	<input style="width: 80%;" type="text" value="0.65"/>	<input style="width: 80%;" type="text" value="0.65"/>	1.18 New/Old Elec 0.16 Abs/New Elc 0.29 Gas/New Elc	Existing Elect <input style="width: 80%;" type="text" value="0.239"/> kW/tn	New Electric (kW/ton)	<input style="width: 80%;" type="text" value="0.55"/>	<input style="width: 80%;" type="text" value="0.55"/>	New Elect <input style="width: 80%;" type="text" value="0.239"/> kW/tn	Absorption (COP)	<input style="width: 80%;" type="text" value="1.02"/>	<input style="width: 80%;" type="text" value="1.02"/>	Absorption <input style="width: 80%;" type="text" value="0.315"/> kW/tn	Engine Driven (COP)	<input style="width: 80%;" type="text" value="1.83"/>	<input style="width: 80%;" type="text" value="2.77"/>	Eng Driven <input style="width: 80%;" type="text" value="0.269"/> kW/tn	Monthly Peak Cooling Load (% of peak)				Jan	<input style="width: 80%;" type="text" value="0"/>	Feb	<input style="width: 80%;" type="text" value="0"/>	May	<input style="width: 80%;" type="text" value="98"/>	Jun	<input style="width: 80%;" type="text" value="100"/>	Sep	<input style="width: 80%;" type="text" value="0"/>	Oct	<input style="width: 80%;" type="text" value="0"/>	Mar	<input style="width: 80%;" type="text" value="0"/>	Nov	<input style="width: 80%;" type="text" value="0"/>	Apr	<input style="width: 80%;" type="text" value="0"/>	Dec	<input style="width: 80%;" type="text" value="0"/>	Jul	<input style="width: 80%;" type="text" value="0"/>		<input style="width: 80%;" type="text" value="98"/>				<input style="width: 80%;" type="text" value="0"/>
Peak Load:	<input style="width: 80%;" type="text" value="1,310"/>	tons																																																																		
Annual Hours of Operation:	<input style="width: 80%;" type="text" value="435"/>	hours																																																																		
Equivalent Full Load Hour Percentage:	<input style="width: 80%;" type="text" value="48"/>	% (for most air conditioning applications, EFLH = 50 %)																																																																		
Cooling Peak Load/Ave Load Ratio:	41.86																																																																			
Chiller Efficiencies:	Peak	IPLV	COP Ratio	Parasitic Electrical Requirements:																																																																
Existing Electric (kW/ton)	<input style="width: 80%;" type="text" value="0.65"/>	<input style="width: 80%;" type="text" value="0.65"/>	1.18 New/Old Elec 0.16 Abs/New Elc 0.29 Gas/New Elc	Existing Elect <input style="width: 80%;" type="text" value="0.239"/> kW/tn																																																																
New Electric (kW/ton)	<input style="width: 80%;" type="text" value="0.55"/>	<input style="width: 80%;" type="text" value="0.55"/>		New Elect <input style="width: 80%;" type="text" value="0.239"/> kW/tn																																																																
Absorption (COP)	<input style="width: 80%;" type="text" value="1.02"/>	<input style="width: 80%;" type="text" value="1.02"/>		Absorption <input style="width: 80%;" type="text" value="0.315"/> kW/tn																																																																
Engine Driven (COP)	<input style="width: 80%;" type="text" value="1.83"/>	<input style="width: 80%;" type="text" value="2.77"/>		Eng Driven <input style="width: 80%;" type="text" value="0.269"/> kW/tn																																																																
Monthly Peak Cooling Load (% of peak)																																																																				
Jan	<input style="width: 80%;" type="text" value="0"/>	Feb	<input style="width: 80%;" type="text" value="0"/>																																																																	
May	<input style="width: 80%;" type="text" value="98"/>	Jun	<input style="width: 80%;" type="text" value="100"/>																																																																	
Sep	<input style="width: 80%;" type="text" value="0"/>	Oct	<input style="width: 80%;" type="text" value="0"/>																																																																	
Mar	<input style="width: 80%;" type="text" value="0"/>	Nov	<input style="width: 80%;" type="text" value="0"/>																																																																	
Apr	<input style="width: 80%;" type="text" value="0"/>	Dec	<input style="width: 80%;" type="text" value="0"/>																																																																	
Jul	<input style="width: 80%;" type="text" value="0"/>		<input style="width: 80%;" type="text" value="98"/>																																																																	
			<input style="width: 80%;" type="text" value="0"/>																																																																	

Gas Cooling Analysis		Input Data Sheet																																							
Facility: Warner-Robins AFB, CEP																																									
<div style="display: flex; justify-content: space-between;"> <div style="width: 40%;"> <p>Utility Rates</p> <p>Natural Gas Utility Rates:</p> <table style="width: 100%; border-collapse: collapse;"> <tr> <td style="width: 60%;">Cooling Rate</td> <td style="width: 15%; border: 1px solid black; text-align: center;">0.373</td> <td style="width: 25%;">\$/therm</td> </tr> <tr> <td>Boiler Rate</td> <td style="border: 1px solid black; text-align: center;">0.373</td> <td>\$/therm</td> </tr> <tr> <td>Elect/Gas Use Cost Ratio</td> <td style="border: 1px solid black; text-align: center;">2.91</td> <td></td> </tr> </table> <p>Electric Utility Rates:</p> <table style="width: 100%; border-collapse: collapse;"> <tr> <td style="width: 60%;">Summer Demand</td> <td style="width: 15%; border: 1px solid black; text-align: center;">0.00</td> <td style="width: 10%;">\$/kW</td> <td style="width: 10%;">from</td> <td style="width: 10%; border: 1px solid black; text-align: center;">Mar</td> <td style="width: 5%;">through</td> <td style="width: 10%; border: 1px solid black; text-align: center;">Sep</td> </tr> <tr> <td>Ratchet</td> <td style="border: 1px solid black; text-align: center;">95</td> <td>%</td> <td>from</td> <td style="border: 1px solid black; text-align: center;">Jan</td> <td>through</td> <td style="border: 1px solid black; text-align: center;">Dec</td> </tr> <tr> <td>Winter Demand</td> <td style="border: 1px solid black; text-align: center;">0.00</td> <td>\$/kW</td> <td colspan="4">Demand\$/Use\$ Ratio (hrs)</td> </tr> <tr> <td>Energy</td> <td style="border: 1px solid black; text-align: center;">0.037</td> <td>\$/kWh</td> <td>Smr. EI/Gas:</td> <td style="border: 1px solid black; text-align: center;">0</td> <td>Wntr EI/Gas:</td> <td style="border: 1px solid black; text-align: center;">0</td> </tr> </table> </div> <div style="width: 55%; border: 1px solid black; padding: 5px; font-size: small;"> <p>Notes: Centrifugal Water Cooled, NG and Elec Plant already has (2) 1500 and (1) 750 ton electric units Using report parasitic estimates Base loaded Chiller (100% year round) Engine waste heat considers both exhaust gases and cooling jacket water If boiler fuel not gas, convert \$/MBtu to \$/therm Can not calculate winter type ratchet charges; input directly?? Must use month format Xxx (i.e Jan, Feb)</p> </div> </div>			Cooling Rate	0.373	\$/therm	Boiler Rate	0.373	\$/therm	Elect/Gas Use Cost Ratio	2.91		Summer Demand	0.00	\$/kW	from	Mar	through	Sep	Ratchet	95	%	from	Jan	through	Dec	Winter Demand	0.00	\$/kW	Demand\$/Use\$ Ratio (hrs)				Energy	0.037	\$/kWh	Smr. EI/Gas:	0	Wntr EI/Gas:	0		
Cooling Rate	0.373	\$/therm																																							
Boiler Rate	0.373	\$/therm																																							
Elect/Gas Use Cost Ratio	2.91																																								
Summer Demand	0.00	\$/kW	from	Mar	through	Sep																																			
Ratchet	95	%	from	Jan	through	Dec																																			
Winter Demand	0.00	\$/kW	Demand\$/Use\$ Ratio (hrs)																																						
Energy	0.037	\$/kWh	Smr. EI/Gas:	0	Wntr EI/Gas:	0																																			
<div style="border: 1px solid black; padding: 5px; margin: 5px auto; width: 80%;"> NOTE: Review demand charge calculations to determine appropriate values to enter for number of applicable months. </div> <div style="border: 1px solid black; padding: 5px; margin: 5px auto; width: 80%;"> NOTE: The above rates should include any applicable taxes and surcharges. </div>																																									
<p>Equipment Cost</p> <table style="width: 100%; border-collapse: collapse;"> <thead> <tr> <th rowspan="2"></th> <th>Chiller</th> <th>Rebate</th> <th>Installation</th> <th>Maintenance</th> </tr> <tr> <th>\$/ton</th> <th>\$/ton</th> <th>\$/ton</th> <th></th> </tr> </thead> <tbody> <tr> <td>Electric (existing)</td> <td style="background-color: black;"></td> <td></td> <td></td> <td style="border: 1px solid black; text-align: center;">0.008 \$/ton-hr</td> </tr> <tr> <td>Electric (new)</td> <td style="border: 1px solid black; text-align: center;">418</td> <td style="border: 1px solid black; text-align: center;">0</td> <td style="border: 1px solid black; text-align: center;">387</td> <td style="border: 1px solid black; text-align: center;">0.006 \$/ton-hr</td> </tr> <tr> <td>Absorption</td> <td style="border: 1px solid black; text-align: center;">672</td> <td style="border: 1px solid black; text-align: center;">0</td> <td style="border: 1px solid black; text-align: center;">402</td> <td style="border: 1px solid black; text-align: center;">0.0085 \$/ton-hr</td> </tr> <tr> <td>Engine Driven</td> <td></td> <td></td> <td></td> <td></td> </tr> <tr> <td> w/o heat recovery</td> <td style="border: 1px solid black; text-align: center;">577</td> <td style="border: 1px solid black; text-align: center;">0</td> <td style="border: 1px solid black; text-align: center;">328</td> <td style="border: 1px solid black; text-align: center;">0.012 \$/ton-hr</td> </tr> <tr> <td> w/ heat recovery</td> <td style="border: 1px solid black; text-align: center;">606</td> <td style="border: 1px solid black; text-align: center;">0</td> <td style="border: 1px solid black; text-align: center;">407</td> <td style="border: 1px solid black; text-align: center;">0.013 \$/ton-hr</td> </tr> </tbody> </table>				Chiller	Rebate	Installation	Maintenance	\$/ton	\$/ton	\$/ton		Electric (existing)				0.008 \$/ton-hr	Electric (new)	418	0	387	0.006 \$/ton-hr	Absorption	672	0	402	0.0085 \$/ton-hr	Engine Driven					w/o heat recovery	577	0	328	0.012 \$/ton-hr	w/ heat recovery	606	0	407	0.013 \$/ton-hr
	Chiller	Rebate		Installation	Maintenance																																				
	\$/ton	\$/ton	\$/ton																																						
Electric (existing)				0.008 \$/ton-hr																																					
Electric (new)	418	0	387	0.006 \$/ton-hr																																					
Absorption	672	0	402	0.0085 \$/ton-hr																																					
Engine Driven																																									
w/o heat recovery	577	0	328	0.012 \$/ton-hr																																					
w/ heat recovery	606	0	407	0.013 \$/ton-hr																																					
<p>Heat Recovery (Engine Driven Chiller only)</p> <table style="width: 100%; border-collapse: collapse;"> <tr> <td style="width: 40%;">Useful thermal energy</td> <td style="width: 15%; border: 1px solid black; text-align: center;">0</td> <td style="width: 10%;">Btu/hr</td> <td style="width: 10%;">Engine efficiency</td> <td style="width: 10%; border: 1px solid black; text-align: center;">35</td> <td style="width: 5%;">%</td> </tr> <tr> <td>Summer boiler efficiency</td> <td style="border: 1px solid black; text-align: center;">80</td> <td>%</td> <td>Recoverable percent</td> <td style="border: 1px solid black; text-align: center;">75</td> <td>%</td> </tr> <tr> <td></td> <td></td> <td></td> <td>Max avail thermal energy</td> <td colspan="2" style="border: 1px solid black; text-align: center;">2,769,816 Btu/hr</td> </tr> </table>			Useful thermal energy	0	Btu/hr	Engine efficiency	35	%	Summer boiler efficiency	80	%	Recoverable percent	75	%				Max avail thermal energy	2,769,816 Btu/hr																						
Useful thermal energy	0	Btu/hr	Engine efficiency	35	%																																				
Summer boiler efficiency	80	%	Recoverable percent	75	%																																				
			Max avail thermal energy	2,769,816 Btu/hr																																					

Gas Cooling Analysis		Output Data Sheet
Facility: Warner-Robins AFB, CEP		
Existing Electric Chiller Energy Costs		
Chiller Peak Efficiency: 0.65 kW/ton		
Chiller IPLV (seasonal efficiency): 0.65 kW/ton (see note below)		
Energy Charge (chiller): 1,310 tons x 0.650 kW/ton (IPLV) x 209 EFLH x 0.037 \$/kWh		= \$6,588
Energy Charge (parasitic): 1,310 tons x 0.239 kW/ton x 435 operating hr x 0.037 \$/kWh		= \$6,033
Peak Demand: (Monthly and annual peak demand estimates are calculated on the following page)		=
	Total Annual Energy Cost	\$11,621
New Electric Chiller Energy Costs		
Chiller Peak Efficiency: 0.55 kW/ton		
Chiller IPLV (seasonal efficiency): 0.55 kW/ton (see note below)		
Energy Charge (chiller): 1,310 tons x 0.550 kW/ton (IPLV) x 209 EFLH x 0.037 \$/kWh		= \$5,575
Energy Charge (parasitic): 1,310 tons x 0.239 kW/ton x 435 operating hr x 0.037 \$/kWh		= \$6,033
Peak Demand: (Monthly and annual peak demand estimates are calculated on the following page)		=
	Total Annual Energy Cost	\$11,608
Absorption Chiller Energy Costs		
Chiller Peak Efficiency: 1.02 COP		
Incremental Parasitic Power Consumption: 0.315 kW/ton (see note below)		
Chiller IPLV (seasonal efficiency): 1.02 COP - or - 0.118 therms/ton-hr (see note below)		
Gas Charge: 1,310 tons x 0.118 therms/ton-hr x 209 EFLH x 0.373 \$/therm		= \$12,019
Energy Charge (parasitic): 1,310 tons x 0.315 kW/ton x 435 operating hr x 0.037 \$/kWh		= \$6,636
Peak Demand: (Monthly and annual peak demand estimates are calculated on the following page)		=
	Total Annual Energy Cost	\$18,655
Engine Driven Chiller Energy Costs		
Chiller Peak Efficiency: 1.83 COP		
Incremental Parasitic Power Consumption: 0.2687 kW/ton (see note below)		
Chiller IPLV (seasonal efficiency): 2.77 COP - or - 0.043 therms/ton-hr (see note below)		
Heat Recovery: 0.000 BTU/hr		
Boiler Efficiency: 80%		
Gas Charge: 1,310 tons x 0.043 therms/ton-hr x 209 EFLH x 0.373 \$/therm		= \$4,431
Energy Charge (parasitic): 1,310 tons x 0.269 kW/ton x 435 operating hr x 0.037 \$/kWh		= \$6,661
Peak Demand: (Monthly and annual peak demand estimates are calculated on the following page)		=
	Total Annual Energy Cost (without heat recovery)	\$11,092
Savings with Optional Heat Recovery: Btu/hr x 1 therm/100,000 Btu x 209 EFLH x 0.373 \$/therm / 80 % boiler efficiency		=
	Total Annual Energy Cost (with heat recovery)	\$10,092
<p>EFLH = Equivalent Full Load Hours (for most air conditioning applications, EFLH = 0.5 x annual hours of operation)</p> <p>IPLV = Integrated Part Load Value. The IPLV should be used for all electrical energy calculations, since it represents the seasonal average (not full load) operating efficiency of the chiller.</p> <p>Incremental Parasitic Power Consumption = COP (Boiler, Cooling, Chiller, etc.)</p> <p>Direct-fired absorption chillers have significantly higher electric parasitic consumption than electric chillers. This is due to greater condenser flow rates, heat rejection, and pressure drops in the heat exchangers. Engine driven chillers have slightly higher parasitic losses than gas-fired chillers due to the engine heat rejection.</p>		

Gas Cooling Analysis

Output Data Sheet

Facility: Warner-Robins AFB, CEP

Month	Demand Charge (\$/kW)	Existing Electric Chiller		New Electric Chiller		Absorption Chiller		Engine Driven Chiller	
		Billed Demand (kW)	Monthly Charge (\$)	Billed Demand (kW)	Monthly Charge (\$)	Billed Demand (kW)	Monthly Charge (\$)	Billed Demand (kW)	Monthly Charge (\$)
Jan		1,106		982		392		334	
Feb		1,106		982		392		334	
Mar		1,106		982		392		334	
Apr		1,106		982		392		334	
May		1,145		1,017		413		352	
Jun		1,160		1,030		413		352	
Jul		1,106		982		413		352	
Aug		1,137		1,009		413		334	
Sep		1,106		982		392		334	
Oct		1,106		982		392		334	
Nov		1,106		982		392		334	
Dec		1,106		982		392		334	
Aver/Sum		1,117		991		399		340	

Method: Demand Charge (\$/kW) is determined from the utility rate schedule or user provided. Billed Demand (\$/kW) is calculated based on the utility rate structure. If there is no factor associated with the demand charge, the billed demand equals the peak metered demand which occurs during that month. If the utility rate structure has a peak charge, the billed demand is equal to the peak metered demand multiplied by the billed rate charge. Monthly Charge (\$/kW) is calculated by multiplying the billed demand by the billed rate charge. The Annual Average (\$/kW) is the sum of the monthly billed demands and the sum of the billed rate charges. The actual meter demand is the sum of the peak loads of the chillers during the month. The billed demand is the sum of the billed demands for each of the chillers being billed. The absorption meter, condenser water pumps, and cooling tower fans are not included.

Gas Cooling Analysis		Output Data Sheet		
Facility: Warner-Robins AFB, CEP				
Maintenance Costs		Maintenance Costs		
Electric Chiller Maintenance Costs				
Existing	209.2785 EFLH	x 1310 tons	x 0.008 \$/ton-hr = \$2,193	
New	209.2785 EFLH	x 1310 tons	x 0.006 \$/ton-hr = \$1,646	
Absorption Chiller Maintenance Costs				
	209.2785 EFLH	x 1310 tons	x 0.0065 \$/ton-hr \$2,330	
Engine Driven Chiller Maintenance Costs				
w/ heat recovery	209.2785 EFLH	x 1310 tons	x 0.012 \$/ton-hr \$3,290	
w/ heat recovery	209.2785 EFLH	x 1310 tons	x 0.013 \$/ton-hr \$3,564	
Annual Operating Costs (Energy + Maintenance)				
		\$13,814		
		\$12,252		
		\$20,986		
		\$13,382		
		\$13,656		
System Installed Cost				
Equipment Cost		Installation Cost		
Electric Chiller Installed Costs				
418 \$/ton	x 1310 tons	+ 387 \$/ton	x 1310 tons = \$1,054,550	
Absorption Chiller Installed Costs				
672 \$/ton	x 1310 tons	+ 402 \$/ton	x 1310 tons = \$1,406,940	
Engine Driven Chiller Installed Costs				
577 \$/ton	x 1310 tons	+ 328 \$/ton	x 1310 tons = \$1,185,550	
w/ heat recovery	606 \$/ton	x 1310 tons	+ 407 \$/ton	x 1310 tons = \$1,327,030
Incremental Simple Payback		Incremental Simple Payback		
		basecase		
		NEVER		
		NEVER		
		NEVER		
		NEVER		
<small> Annual Operating Cost = Annual Energy Cost + Annual Maintenance Cost Installed Cost = Chiller Cost per Ton * Capacity + Installation Cost per Ton * Chiller Capacity Cost Premium = installed cost of a specific chiller type - installed cost of an electric chiller Incremental Simple Payback = Cost Premium/Electric Chiller Annual Operating Cost - Specific Chiller Annual Operating Cost </small>				

Appendix B: Performance Data of Chillers 5 and 6

Warner-Robins AFB Chiller #5 Load: June 2000

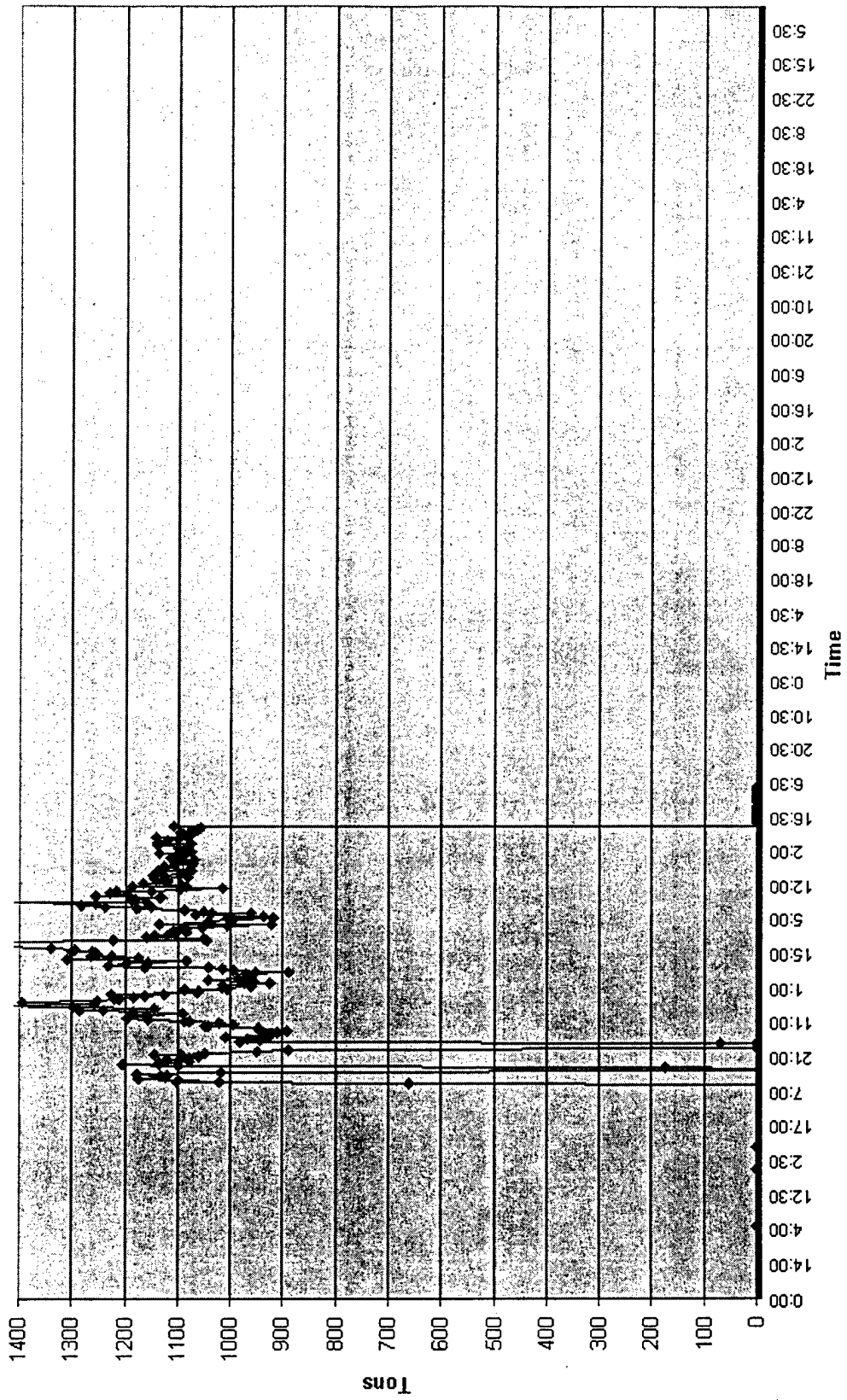

Warner-Robins AFB Chiller #6 Load: May 2000

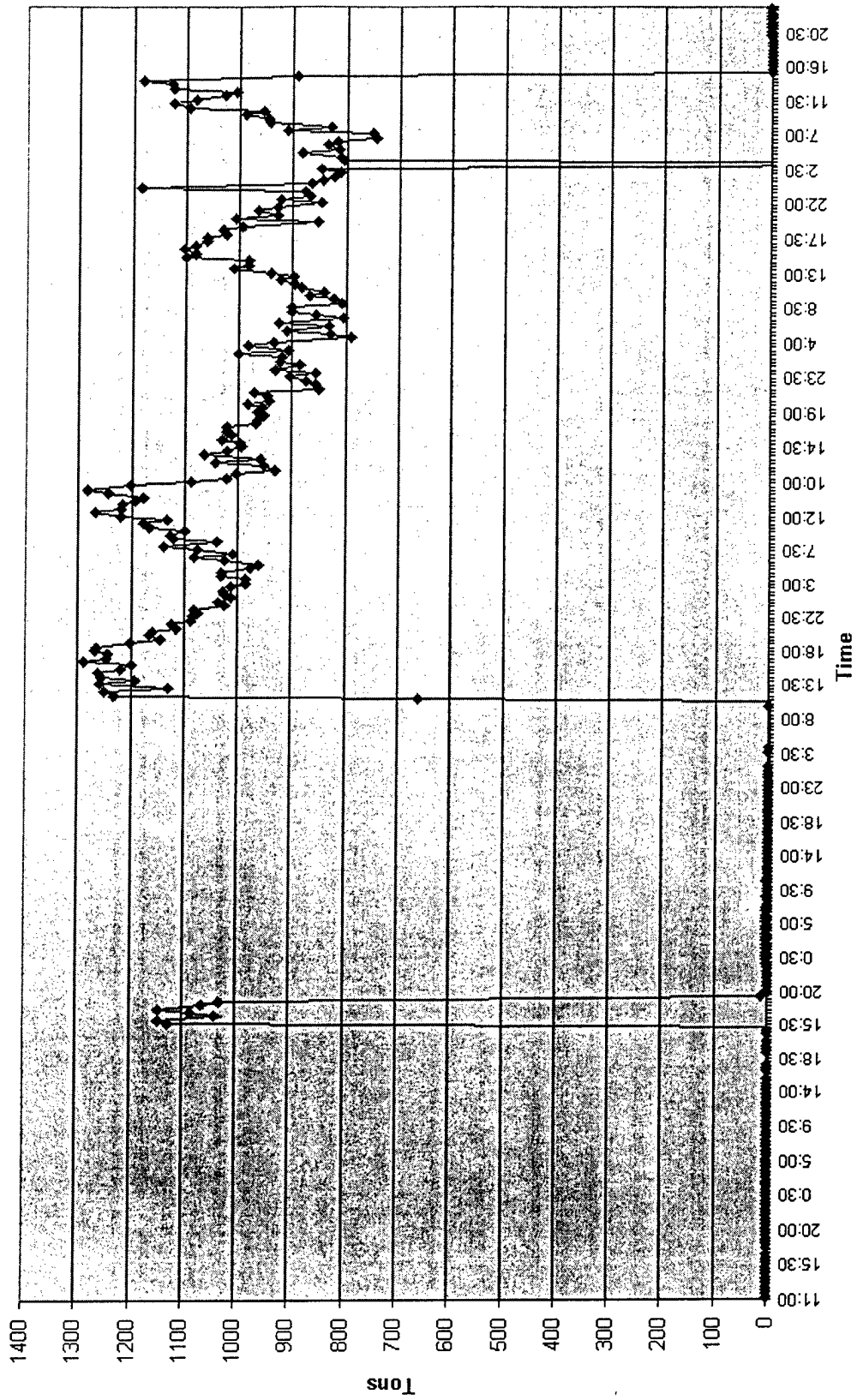

Warner-Robins AFB Chiller #6 Load: June 2000

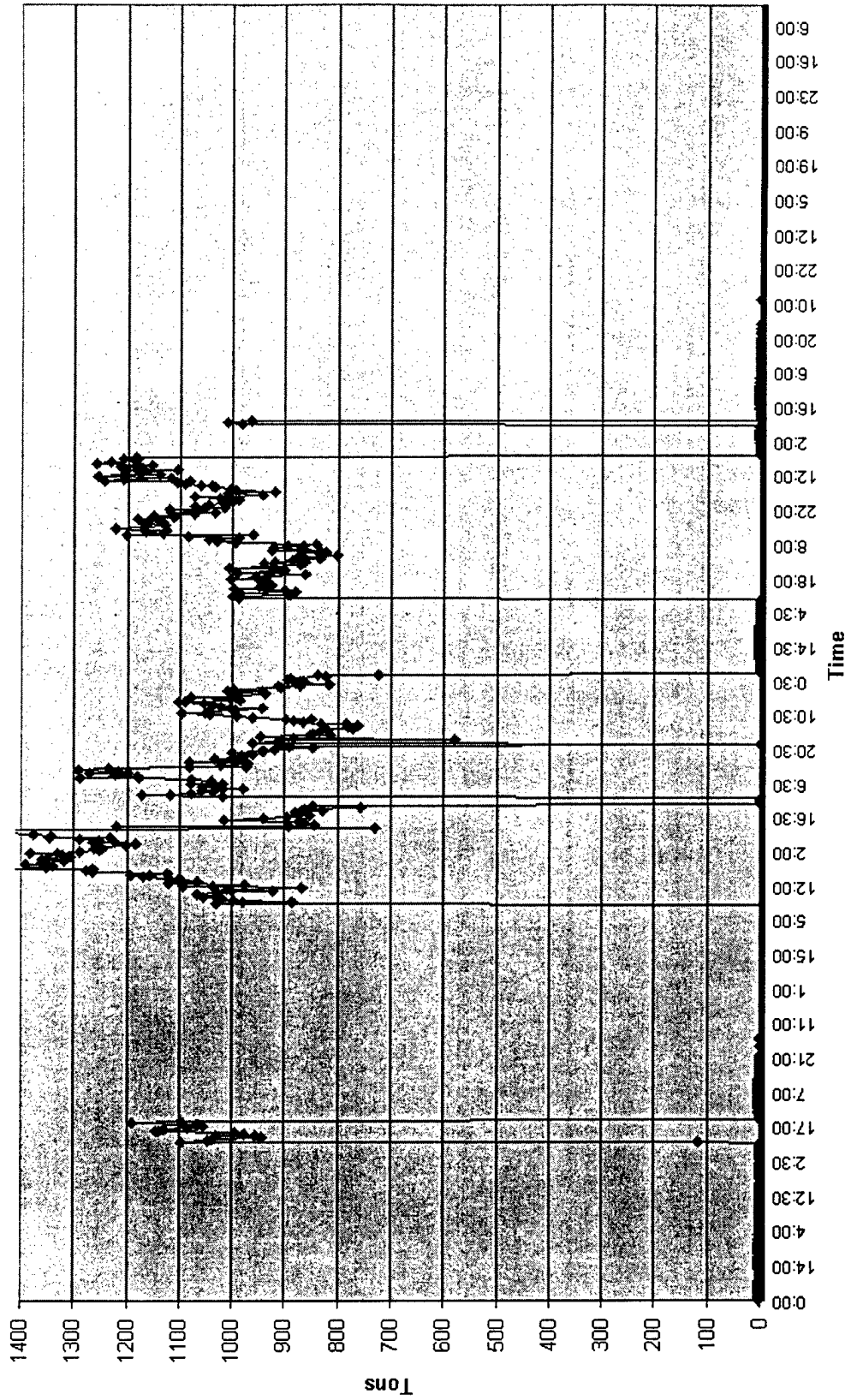

Warner-Robins AFB Chiller #6 Load: August 2000

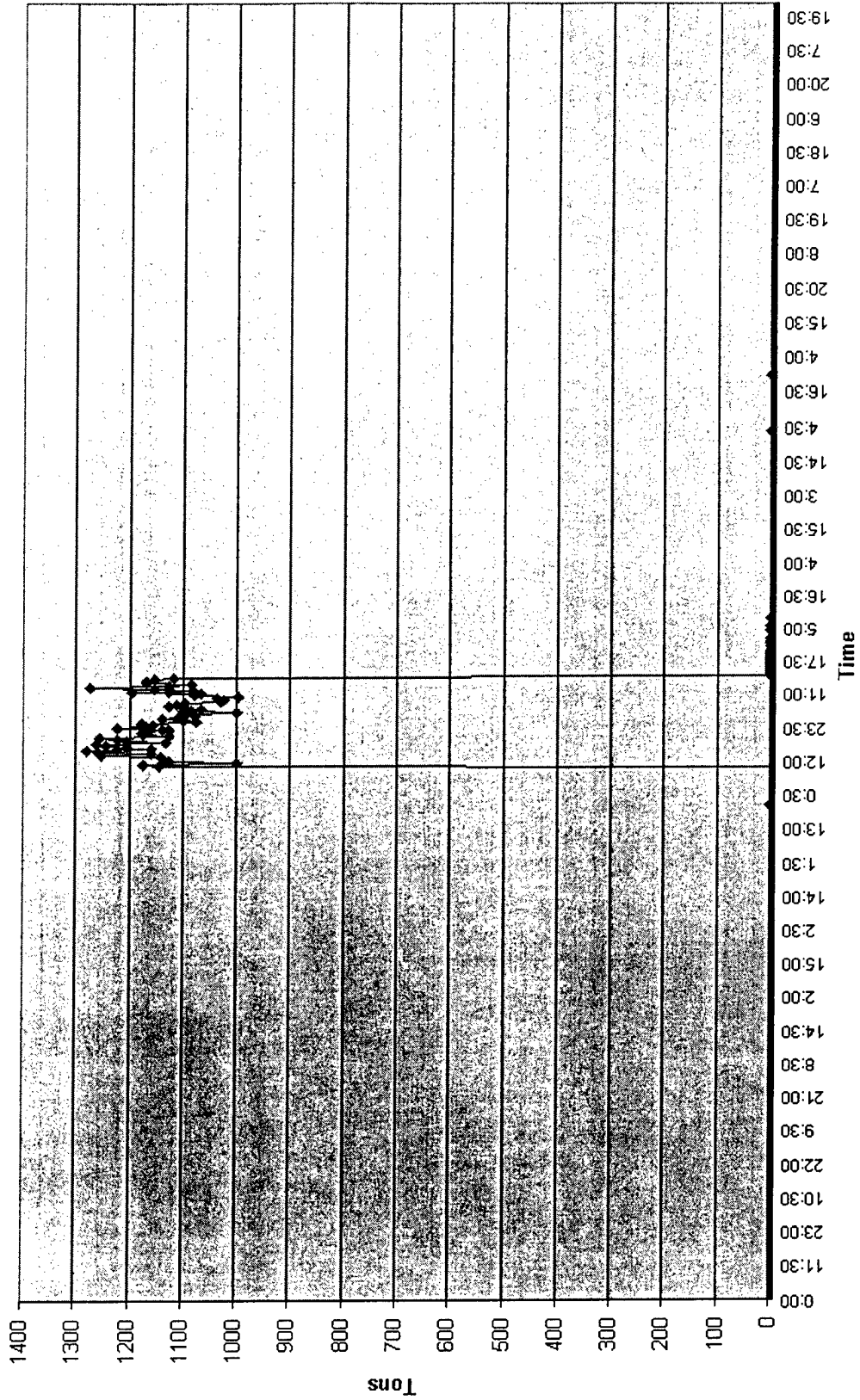

Abbreviations and Acronyms

AFB	Air Force Base
AFCESA	Air Force Civil Engineer Support Agency
ANG	Air National Guard
ARS	Air Reserve Station
Btu	British thermal unit
CERL	U.S. Army Construction Engineering Research Laboratory
CFC	chlorofluorocarbon
CHW	chilled water
CHWR	chilled water return
CHWS	chilled water supply
COP	Coefficient of Performance
DDC	direct digital control
deg F	degrees Fahrenheit
DOD	Department of Defense
FY	fiscal year
gpm	gallons per minute
HCFC	hydrochlorofluorocarbon
HFC	hydrofluorocarbon
HHV	higher heating value
kW	kilowatt
kWh	kilowatt-hour
MBtu	million British thermal units
SCF	standard cubic feet
SCFH	standard cubic feet per hour
TDY	temporary duty

CERL Distribution

HQ AFCESA, Tyndall AFB
ATTN: AFCESA/CESM (2)

Chief of Engineers
ATTN: CEHEC-IM-LH (2)

Engineer Research and Development Center (Libraries)
ATTN: ERDC, Vicksburg, MS
ATTN: Cold Regions Research, Hanover, NH
ATTN: Topographic Engineering Center, Alexandria, VA

Defense Tech Info Center 22304
ATTN: DTIC-O

8
5/00

