

REPORT DOCUMENTATION PAGE

Form Approved
OMB NO. 0704-0188

Public Reporting burden for this collection of information is estimated to average 1 hour per response, including the time for reviewing instructions, searching existing data sources, gathering and maintaining the data needed, and completing and reviewing the collection of information. Send comment regarding this burden estimates or any other aspect of this collection of information, including suggestions for reducing this burden, to Washington Headquarters Services, Directorate for information Operations and Reports, 1215 Jefferson Davis Highway, Suite 1204, Arlington, VA 22202-4302, and to the Office of Management and Budget, Paperwork Reduction Project (0704-0188,) Washington, DC 20503.

1. AGENCY USE ONLY (Leave Blank)		2. REPORT DATE	3. REPORT TYPE AND DATES COVERED FINAL 01 May 98 - 30 Apr 01	
4. TITLE AND SUBTITLE Composite Materials for Optical Limiting		5. FUNDING NUMBERS DAAG55-98-1-0271		
6. AUTHOR(S) Lee Spangler				
7. PERFORMING ORGANIZATION NAME(S) AND ADDRESS(ES) Montana State University		8. PERFORMING ORGANIZATION REPORT NUMBER		
9. SPONSORING / MONITORING AGENCY NAME(S) AND ADDRESS(ES) U. S. Army Research Office P.O. Box 12211 Research Triangle Park, NC 27709-2211		10. SPONSORING / MONITORING AGENCY REPORT NUMBER 37782.1-CH-DPS		
11. SUPPLEMENTARY NOTES The views, opinions and/or findings contained in this report are those of the author(s) and should not be construed as an official Department of the Army position, policy or decision, unless so designated by other documentation.				
12 a. DISTRIBUTION / AVAILABILITY STATEMENT Approved for public release; distribution unlimited.		12 b. DISTRIBUTION CODE		
13. ABSTRACT (Maximum 200 words) This project funded two principle investigators to explore materials for optical limiting. Dr. Charles Spangler's research group synthesized organic and dendritic materials designed to optically limit via reverse saturable absorption (RSA) via photoinduced formation of charged states. Dr. Lee Spangler's research group investigated the spectroscopy, mechanism, and efficiency of photo-induced states in these, and related compounds. Thus, the technical part of the report will be divided into two sections, synthesis and characterization.				
14. SUBJECT TERMS		15. NUMBER OF PAGES 17		16. PRICE CODE
17. SECURITY CLASSIFICATION OR REPORT UNCLASSIFIED	18. SECURITY CLASSIFICATION ON THIS PAGE UNCLASSIFIED	19. SECURITY CLASSIFICATION OF ABSTRACT UNCLASSIFIED	20. LIMITATION OF ABSTRACT UL	

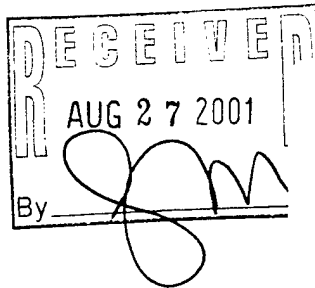

20011023 046

MASTER COPY: PLEASE KEEP THIS "MEMORANDUM OF TRANSMITTAL" BLANK FOR REPRODUCTION PURPOSES. WHEN REPORTS ARE GENERATED UNDER THE ARO SPONSORSHIP, FORWARD A COMPLETED COPY OF THIS FORM WITH EACH REPORT SHIPMENT TO THE ARO. THIS WILL ASSURE PROPER IDENTIFICATION. NOT TO BE USED FOR INTERIM PROGRESS REPORTS; SEE PAGE 2 FOR INTERIM PROGRESS REPORT INSTRUCTIONS.

MEMORANDUM OF TRANSMITTAL

U.S. Army Research Office
ATTN: AMSRL-RO-BI (TR)
P.O. Box 12211
Research Triangle Park, NC 27709-2211

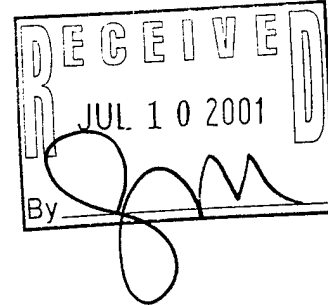

- Reprint (Orig + 2 copies)
- Manuscript (1 copy)
- Technical Report (Orig + 2 copies)
- Final Progress Report (Orig + 2 copies)
- Related Materials, Abstracts, Theses (1 copy)

CONTRACT/GRANT NUMBER: DAAG55-98-1-0271

REPORT TITLE: Final Progress Report: Composite Materials for Optical Limiting

is forwarded for your information.

SUBMITTED FOR PUBLICATION TO (applicable only if report is manuscript):

2001 JUL -9 AM 10:08

Sincerely,

Enclosure 3

Final Progress Report: DAAG55-98-1-0271, Composite Materials for Optical Limiting
Lee H. Spangler and Charles W. Spangler, Department of Chemistry, Montana State University
ARO Program Officer: Douglas J. Kisarow

(1) Foreword

This project funded two principal investigators to explore materials for optical limiting. Dr. Charles Spangler's research group synthesized organic and dendritic materials designed to optically limit via reverse saturable absorption (RSA) via photoinduced formation of charged states. Dr. Lee Spangler's research group investigated the spectroscopy, mechanism, and efficiency of photo-induced states in these, and related compounds. Thus, the technical part of the report will be divided into two sections, synthesis, and characterization.

(2) Table of Contents (if report is more than 10 pages)

Statement of Problem.....	2
Summary of the most important results	4
Synthesis	4
Characterization	8
Listing of all publications.....	15
List of all participating scientific personnel	16
Bibliography	16

(4) Statement of the problem studied

Rapid advances in laser technology have resulted in new and improved performance laser systems that are compact, efficient and operate at a variety of wavelengths. Such progress has resulted in at least one portable laser weapon system marketed by Norinco of China [1] capable of inflicting severe eye damage at a range of 2-6 miles. The use of lasers has also become widespread in a variety of applications including remote sensing, ranging, and guidance systems. This increased presence of lasers in "friendly" applications and enemy weapons presents significant hazards to the eyesight of ground based military personnel, optical sensors, and military and commercial aircraft pilots. As a result, there is a need for methods to protect both human eyes and optical sensors from intense laser radiation. Potentially, there are a large number of wavelengths that could be generated in laser weapons and the protection scheme must also have a wide range of response times; from sub-nanosecond to block lasers with short pulse emission, to tens of microseconds to block quasi-cw sources. This combination of requirements places severe restrictions on materials, making it extremely difficult for a single material to satisfy all requirements.

This program developed a new class of optical limiting materials and employed new spectroscopic methods capable of studying the mechanisms by which these materials operate. Central to this project is the ability to systematically vary parameters and study the effect of those parameters on dynamics of the transient species responsible for the optical limiting behavior. As a result of this approach we have both identified promising materials and deepened understanding of the photophysics involved and required to get good limiting performance. These new materials which were investigated are organic and dendritic materials[2, 3] capable of forming highly absorbing polarons [4-8] which can function as the transient state for reverse saturable absorption (RSA).

In order to achieve good optical limiting via RSA the transient species must have certain properties: 1) It must have a higher absorption cross section than the linear, ground state absorption. 2) There must be overlap between the absorption of the ground state and the transient species. 3) The transient species must form in a time that is short relative to the pulse duration of the laser threat. 4) It must form efficiently (with a high branching ratio) from the initially pumped state. And 5) it must relax slowly enough that there isn't significant loss of population via relaxation during the laser pulse. Given the large number of parameters that can strongly effect limiting performance, it is clearly advantageous to be able to measure these

parameters as opposed to simply doing performance characterization. If the metastable state properties mentioned above can be measured, it may be possible to establish structure-property relationships and begin to rationally engineer improvements in optical limiters. This project implemented methods which yield high information content in a relatively short time providing the following information: 1) Relative absorption strengths of the ground state and all photo-induced absorptions. 2) Photo-induced absorption wavelengths over a broad spectral range. 3) Formation rates of the metastable species. 4) Relaxation rates for all species.

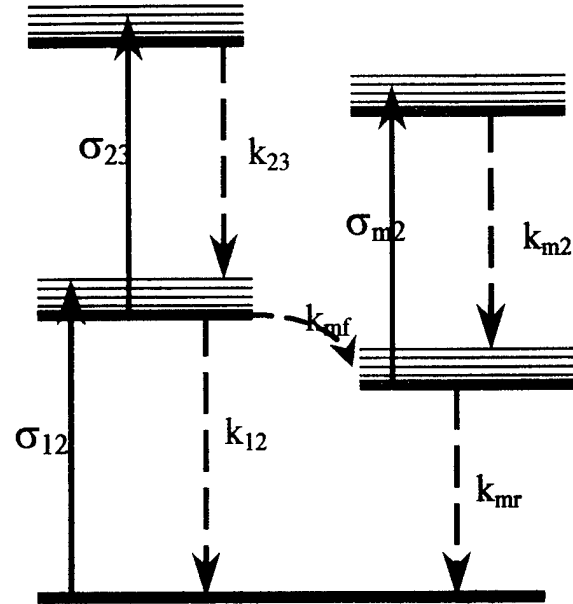

(5) Summary of the most important results

Synthesis of new RSA materials based on photogeneration of highly absorbing charge states

During the past 10-15 years, the C. Spangler research group has synthesized a large number of diphenyl and dithienyl polyenes that have been examined from the perspective of establishing structure-property relationships for a variety of photonic properties, including, for example, their third order nonlinear hyperpolarizabilities and most recently, the magnitude of their intrinsic and effective two-photon cross-sections. [6,9,10] Besides the obvious approach of simply extending the conjugation length, one of the more effective ways of enhancing the third order nonlinearity is by chemical oxidation (doping) which introduces highly delocalized polaronic radical-cations or bipolaronic dications into the conjugation sequence.[8] The formation of these charge states is normally accompanied by the complete bleaching of the original $\pi-\pi^*$ transition and the appearance of a new band that is red-shifted from the neutral absorption band. In the large majority of examples, this new polaronic or bipolaronic band is much more highly absorbing than the original neutral species. In addition, these charge states can be dramatically stabilized by inclusion of mesomerically interactive electron-donating substituents on the aromatic ring termini, as illustrated below for 1,2-bis(diphenylamino)-E-stilbene:

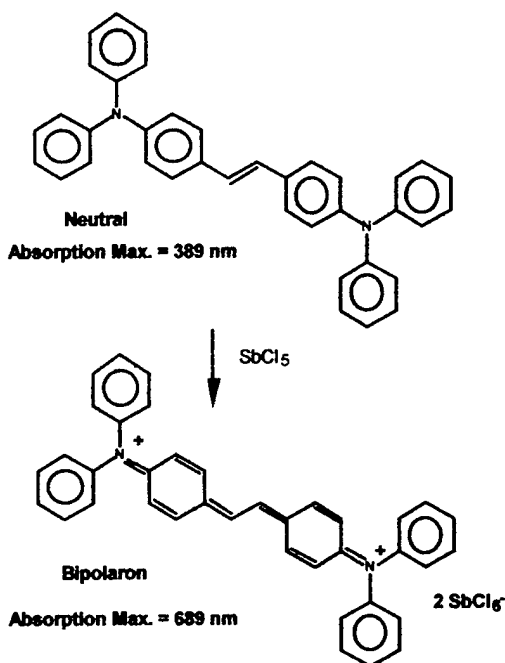

Recently we have reported on the synthesis of a series of bis-(diphenylamino)diphenyl-polyenes[11], which have rather unique properties. The substitution of phenyl rings for alkyl groups on the amino functionality greatly enhances the solubility. The phenyl substituents also increase both the thermal and photochemical stability. We have synthesized this series up to the decaene level, and the polyenes are still soluble and processible in common organic solvents, in marked contrast to the bis-(dimethylamino)diphenylpolyene series. We have been able to functionalize these new materials for attachment as pendant groups to PMMA[12], or difunctionalize them for copolymer formation[13]. However, such functionalization is not trivial, and we have recently replaced one of the diphenylamino substituents with a N-(hydroxyethyl),N-

ethylaminophenyl substituents with no loss of thermal or photochemical stability, but with the derivatizing functionality already established in the chromophore. These chromophores can be readily attached to PMMA as pendant groups or difunctionalized for copolymer incorporation[11]. Upon chemical oxidation, both polyene series form exceptionally stable, highly absorbing bipolarons in solution. Previous to our study of these polyene families, stable bipolarons could not be formed in diphenyl or dithienyl polyenes containing less than 4 conjugated double bonds. However, with diphenylamino or N-(hydroxyethyl),N-ethylaminophenyl substituents, even the bis-substituted stilbenes form stable bipolaronic dications. The synthetic route to the N-ethyl,N-hydroxyethyl stilbene is illustrated in Figure 1.

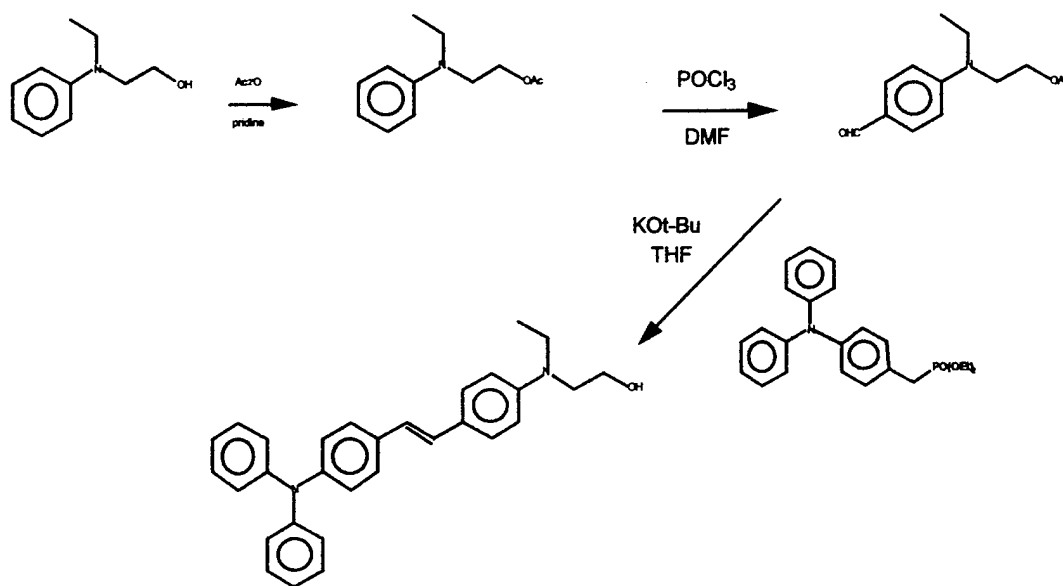

Figure 1. Synthesis of N-(hydroxyethyl),N-ethylaminostilbene.

We have previously described how bis-(diphenylamino)diphenylpolyene units can be attached to a PMMA backbone by reaction of the functionalized chromophore with poly(methacryloyl chloride) followed by quenching in excess methanol[11]. We have used this technique as a means of comparing very different chromophores to one another, as the post-polymerization attachment dictates that the polymer MW and polydispersity are approximately the same for each and every case. We have previously standardized on a 10% incorporation for a variety of studies and to maintain solubility and processibility. For example, in optical power limiting studies, a high degree of linear transmission through the solution or film is required (>60%). The 10% incorporation level provides such optical transparency. The pendant polymers prepared from commercially available poly(methacryloyl chloride) are not ideal, since this approach limits the MW/polydispersity to that of the commercial sample. In addition, increasing the percentage loading of the chromophores also reduces the solubility, and several attempts to achieve a maximum chromophore loading seems to limit at 30-40% in terms of processibility. Therefore, we decided during the course of this grant program to adapt synthetic methodology developed by Frechet, et al. [14, 15] to incorporate our chromophores into dendrons based on 3,5-dihydroxybenzyl alcohol. These intermediary dendrons can, in turn, be converted into model

G-0 dendrimers by coupling to core molecules such as bis-phenol A. The dendron and dendrimer formation is illustrated in Figures 2 and 3.

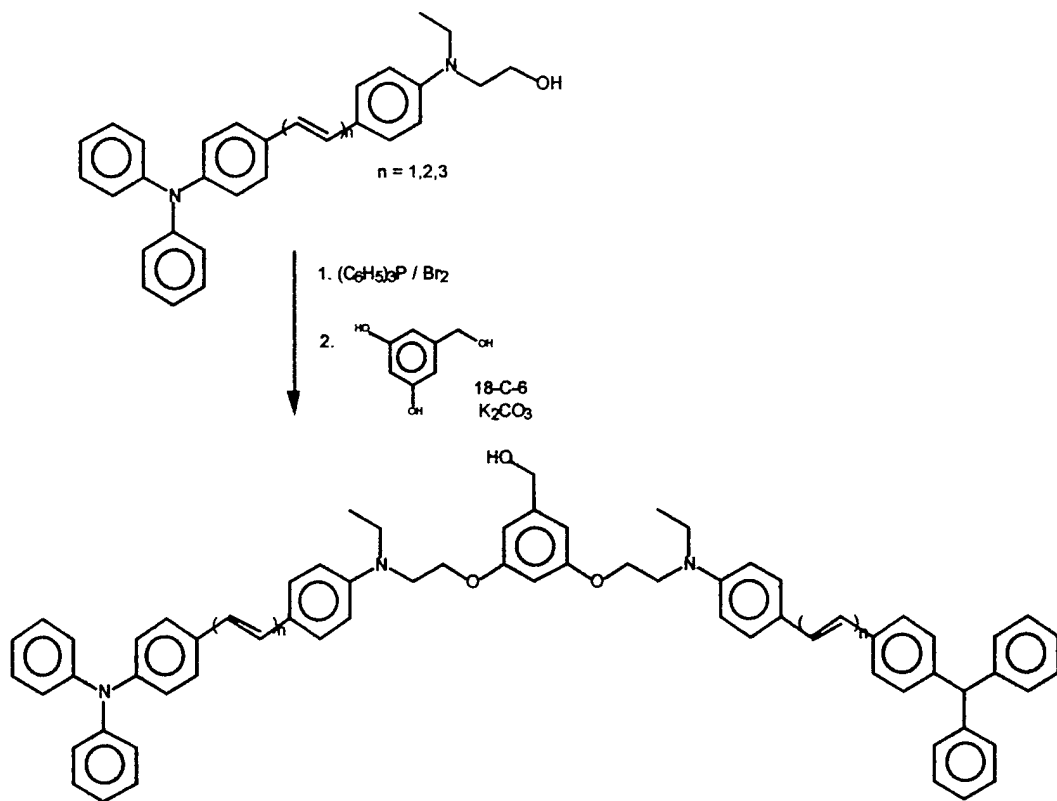

Figure 2. Attachment of OPL Chromophores to form Dendrons

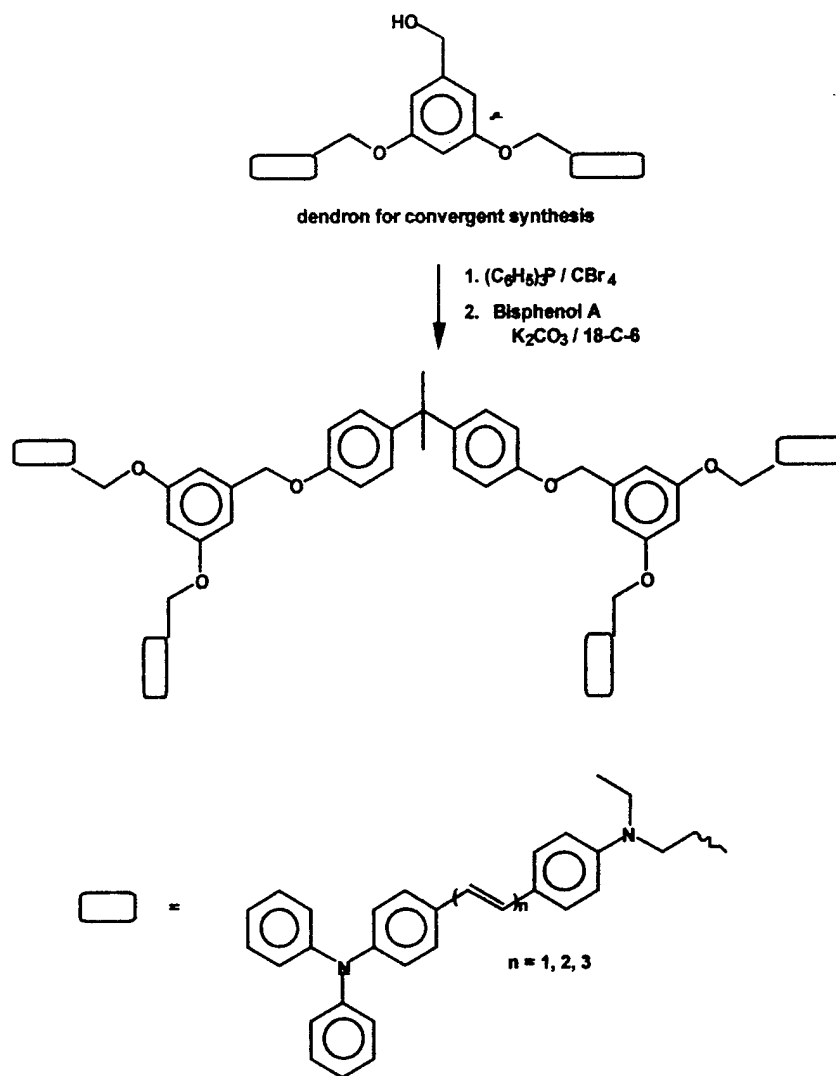

Figure 3. Formation of G-0 dendrimers.

An alternative approach to the surface-functionalized dendrimers illustrated above is to design dendrimers based on photonic active building blocks. Following the rationale described above for the surface-functionalized dendrimers, we have recently described the preparation of model 3-arm and 4-arm dendrimers based on 1,2-bis-(diphenylamino)stilbene building blocks[16]. These model dendrimers are illustrated below. One possible advantage of using dendrimers having this type of structure is that a photon may be absorbed by encountering any part of the dendrimer. It can be further stabilized by electron delocalization over the whole dendrimer volume. Charge state formation could also be further stabilized by incorporating electron donating substituents on the terminal phenyl rings of either the 3-arm or 4-arm structure. Both dendrimers exhibit extremely large two-photon absorption for nanosecond pulses at 810 nm (as high as 65,000 GM units), among the largest yet measured for monodisperse macromolecules. These large effective cross-sections have been rationalized on the basis of large contributions from excited state absorption following the initial two-photon absorption event (on the nanosecond timescale). Thus these dendrimers may be ideal candidates for reverse saturable absorption optical power limiting if the same, or similar, excited state manifold can be accessed by an electron-transfer process. One particularly interesting question is whether the surface-

functionalized dendrimers or the dendrimers based on photonic building blocks are more effective as RSA optical limiters.

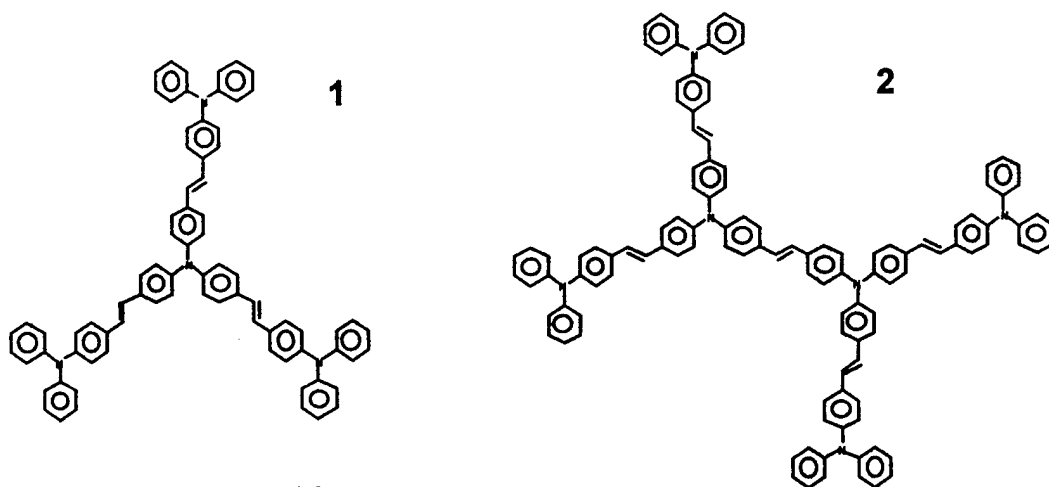

Figure 4. Some dendrimer structures.

In the Characterization section of this report, we will attempt to address the questions raised by the rationale design of these potential optical power limiting materials.

Characterization.

A RSA process involving photo-induced electron transfer (PIET) as the initial absorption step, followed by additional absorption due to one of the newly created charged species, was the targeted mechanism to achieve overall non-linear absorption. The compounds investigated under this grant were predominantly electron donors and C_{60} was used as a photo-induced electron acceptor to determine the PIET behavior of the new donor compounds. C_{60} was chosen for several reasons; it can be pumped at 532 nm (doubled Nd:YAG) and 514 (Ar^+ laser), it has a long-lived triplet state from which the electron transfer occurs making dilute solution studies practical, and its triplet and charge state behavior is well characterized. Two main methods were used to obtain photo-induced absorption (PIA) spectra of the compounds in donor-acceptor solutions and thin films. The first method was to simply acquire a spectrum with the laser off, then with the laser on using our Fourier transform spectrometer and determine the change in OD. The second method utilizes the step scan mode of our instrument to generate fully time and wavelength resolved transient absorption spectra so the kinetics of the PIET process could be followed [17]. Figure 5 shows the compounds studied. Data are provided in tabular format.

Oligimers

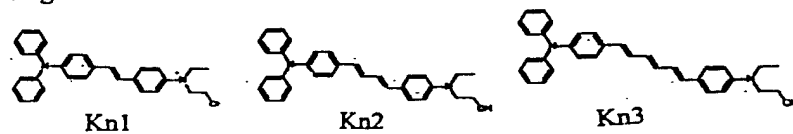

Dendrons

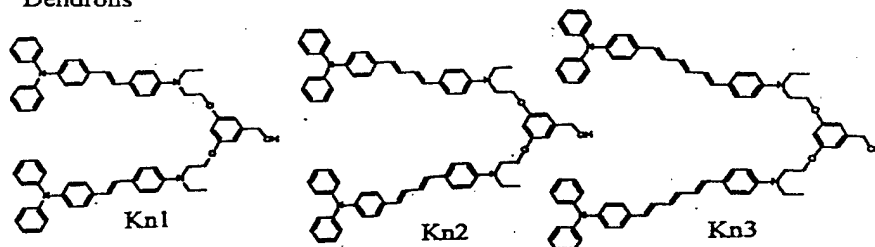

Dendrimers

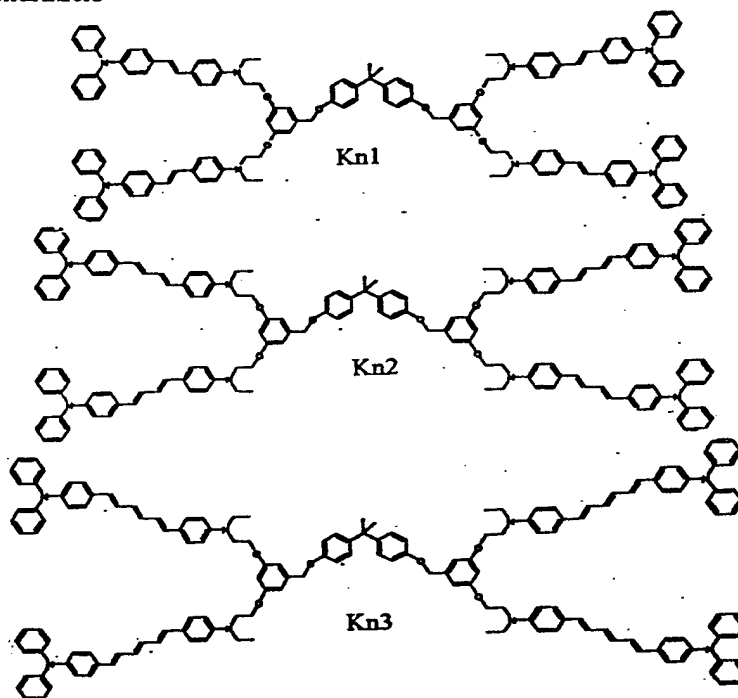

Figure 5. Donor compounds studied for photo-induced electron transfer with C_{60} for RSA applications.

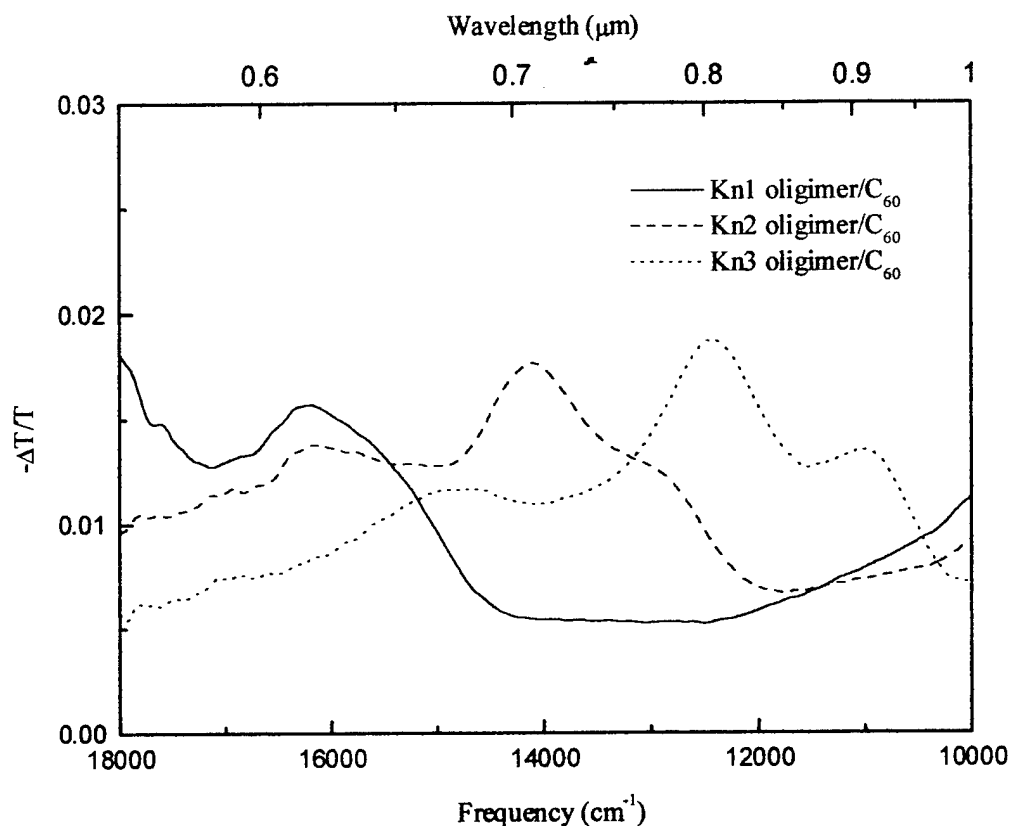

Figure 6. PIA of the Kn1, Kn2 and Kn3 Oligimers with C₆₀. The spectra were taken using the difference method and were pumped at 514nm.

Table 1. Compounds and Concentrations Studied

Compound	Concentration	Compound	Concentration
KN1 oligimer/C ₆₀	0.5mM/0.5mM	KN2 dendrimer/C ₆₀	0.5mM/0.5mM
KN1 dendron/C ₆₀	0.5mM/0.5mM	KN3 oligimer/C ₆₀	0.5mM/0.5mM
KN1 dendrimer/C ₆₀	0.5mM/0.5mM	KN3 dendron/C ₆₀	0.5mM/0.5mM
KN2 oligimer/C ₆₀	0.5mM/0.5mM	KN3 dendrimer/C ₆₀	0.5mM/0.5mM
KN2 dendron/C ₆₀	0.5mM/0.5mM	4arm dendrimer/C ₆₀	0.1mM/0.1mM, 0.25mM/0.25 mM, 0.5mM/0.5mM, 1.0mM/0.5mM

Table 2. Absorption of Tested Species at 532nm. All concentration are 0.5mM each unless otherwise noted. Absorbance is given in absorbance units (A.U.)

Species	Absorption @ 532nm	Species	Absorption @ 532nm
Kn1 oligimer/C60	0.4817	Kn3 oligimer/C60	0.9875
Kn1 dendron/C60	0.4353	Kn3 dendron/C60	0.8023
Kn1 dendrimer/C60	0.4709	Kn3 dendrimer/C60	0.6940
Kn2 oligimer/C60	0.4661	4arm dendrimer/C60 0.1mM each	0.1599
Kn2 dendron/C60	0.4497	4arm dendrimer/C60 0.25mM each	0.2721
Kn2 dendrimer/C60	0.5113	4arm dendrimer/C60 0.5mM each	0.5192
		4arm dendrimer/C60 1mM/0.5mM	0.8466

Table 3. Molar Extinction Coefficients of the Polarons of the Molecules Studied.

<u>Compound</u>	<u>Molar extinction coefficient ($M^{-1} cm^{-1}$)</u>
Kn1 oligimer	68000
Kn1 dendron	89000
Kn1 dendrimer	90000
Kn2 oligimer	37000
Kn2 dendron	32000
Kn2 dendrimer	33000
Kn3 oligimer	104000
Kn3 dendron	115000
Kn3 dendrimer	136000
4 arm dendrimer (visible cation)	67000

PIET follows a mechanism as shown in Figure 7. Rates, and quantum efficiencies were determined from the transient absorption experiments and are reported below.

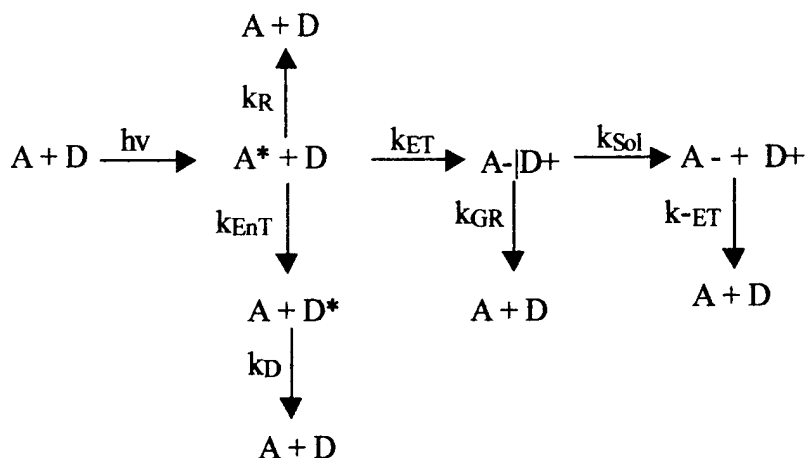

Figure 7. Modified Mechanism for the Photo-Induced Electron Transfer. A is the acceptor, C₆₀, A* is ³C₆₀, D is the donor molecule (see Fig 1) k_R is the “natural” relaxation of the triplet, k_{ET} is the rate constant for electron transfer k_{EnT} is the rate constant for energy transfer, k_D is the rate constant for the decay of the excited donor, k_{GR} is the rate constant for geminate recombination, k_{Sol} is the rate constant for solvation and k_{ET} is the rate of back electron transfer via solvated ion recombination. A⁻|D⁺ is a geminate ion pair

Table 4. Average Recombination Rate Constant, k_{ET}, for the Molecules Studied with C₆₀.

Compound	Average Recombination rate constant (k _{ET}) (L/mol s)	Percent Standard Deviation
Kn1 oligimer	2.5 x 10 ¹⁰	18%
Kn1 dendron	2.2 x 10 ¹⁰	10%
Kn1 dendrimer	1.9 x 10 ¹⁰	23%
Kn2 oligimer	7.8 x 10 ⁹	11%
Kn2 dendron	5.6 x 10 ⁹	14%
Kn2 dendrimer	4.1 x 10 ⁹ (early) 3.5 x 10 ⁹ (late)	5% (early) 19% (late)
Kn3 oligimer	1.6 x 10 ¹⁰	18%
Kn3 dendron	1.7 x 10 ¹⁰ (early) 7.8 x 10 ⁹ (late)	5% (early) 30% (late)
Kn3 dendrimer	1.4 x 10 ¹⁰ (early) 3.8 x 10 ⁹ (late)	10% (early) 5% (late)
4 arm dendrimer 0.1mM each	2 x 10 ¹⁰	10%
4 arm dendrimer 0.25 mM each	3 x 10 ¹⁰	21%
4 arm dendrimer 0.5mM each	2 x 10 ¹⁰	8%
4 arm dendrimer 1mM/0.5mM	2 x 10 ¹⁰	13%

Table 5. Average Forward Electron Transfer Rate Constants for Molecules Studied with C₆₀.
*This rate constant requires more analysis.

<u>Compound</u>	<u>Average Forward electron transfer rate constant (k_{ET}) (L/mol sec)</u>	<u>Percent Standard Deviation</u>
Kn1 oligimer	2.1 x 10 ⁹	4%
Kn1 dendron	3.4 x 10 ⁹	7%
Kn1 dendrimer	3.9 x 10 ⁹	6%
Kn2 oligimer	1.7 x 10 ⁹	1%
Kn2 dendron	4.0 x 10 ⁹	2%
Kn2 dendrimer	5.0 x 10 ⁹	2%
Kn3 oligimer	7.8 x 10 ⁸	10%
Kn3 dendron	1.0 x 10 ⁹	19%
Kn3 denrimer	1.2 x 10 ⁹	10%
4 arm dendrimer 0.1mM each	2.0 x 10 ⁹	*
4 arm dendrimer 0.25 mM each	*	*
4 arm dendrimer 0.5 mM each	1.9 x 10 ⁹	1%
4 arm dendrimer 1/0.5 mM	3.0 x 10 ⁹	4%

Table 6. Concentrations and Quantum Yields Calculated using [D⁺]_{max} and [A*]_{max} Values.

<u>Compound</u>	<u>Concentration</u>	<u>Quantum Yield</u>	<u>Standard Deviation</u>
Kn1 oligimer	1.5 x 10 ⁻⁶ M	2%	1%
Kn1 dendron	1.9 x 10 ⁻⁶ M	2.5%	
Kn1 dendrimer	1.1 x 10 ⁻⁶ M	1%	5%
Kn2 oligimer	4.4 x 10 ⁻⁶ M	6%	7%
Kn2 dendron	8.2 x 10 ⁻⁶ M	11%	5%
Kn2 dendrimer	9.0 x 10 ⁻⁶ M	12%	2%
Kn3 oligimer	8.8 x 10 ⁻⁷ M	1%	10%
Kn3 dendron	5.5 x 10 ⁻⁷ M	1%	17%
Kn3 dendrimer	3.8 x 10 ⁻⁷ M	0.5%	2%
4 arm dendrimer 0.5mM	6.8 x 10 ⁻⁶ M	10%	4%
4 arm dendrimer 1/0.5mM	1.3 x 10 ⁻⁵ M	15%	4%
C ₆₀ Triplet	7.5 x 10 ⁻⁵ M		

One particularly interesting result is the effect of multiple chromophores in a dendritic structure on charge recombination (back electron transfer) after solvated ions are formed. This kinetics typically follows second order kinetics as shown by a plot of 1/concentration vs. time as shown in Figure 8 (OD is proportional to concentration).

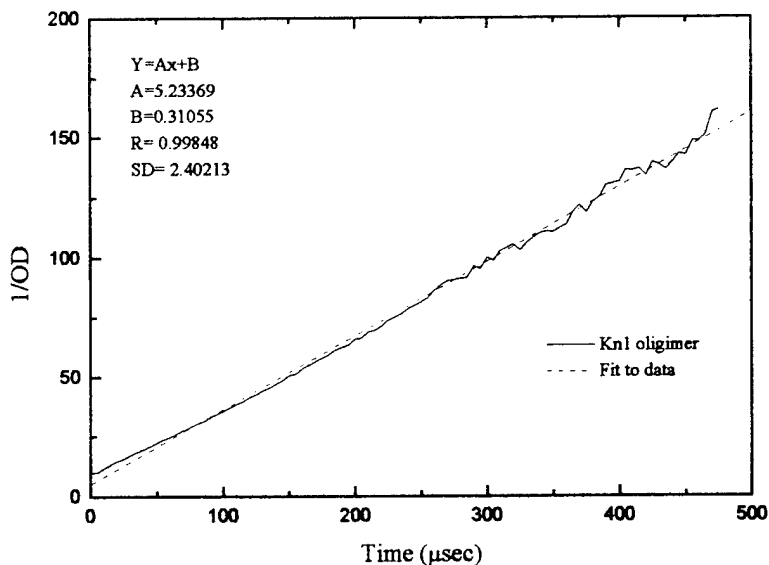

Figure 8. Example of Linear Fit to Reciprocal Optical Density Data.

For the 4-chromophore dendrimers, particularly with long conjugation length chromophores, the recombination deviated dramatically from this linear behavior. We speculate the hopping or delocalization of the positive charge in the cation state may enhance charge stability and slow recombination.

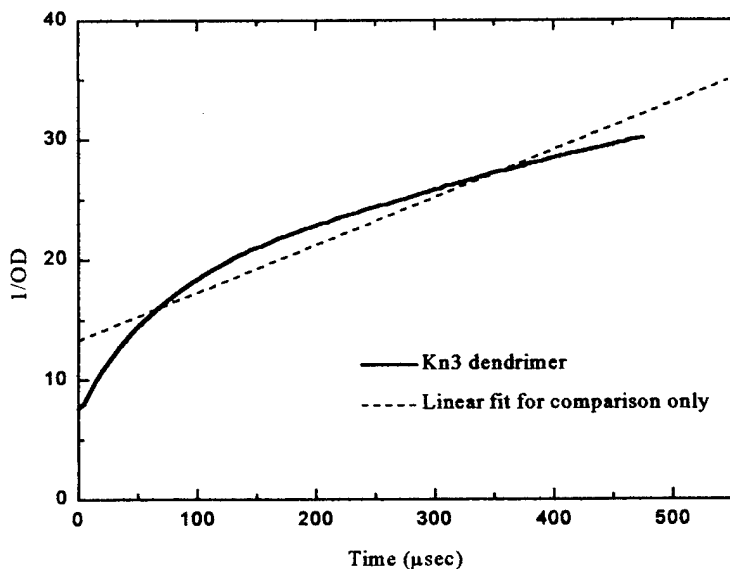

Figure 9. Kn3 Dendrimer Decay Curve with Linear Fit for comparison.

Table 7. Example Rate Constants for the Mechanism in Scheme 3. k_Q includes k_{ET} followed by k_{GR} and k_{ENT} followed by k_R . Literature values are for different donor acceptor systems in various solvents.

Rate Constant	Value from thesis	Value from literature
k_Q	2.1×10^9 L/mol sec	$6.4 \times 10^9 - 1.2 \times 10^{10} \text{ sec}^{-1}$ ¹⁷ 5.7×10^9 L/mol sec in ODCB ⁸
k_{GR}		$\sim 1 \times 10^8 - \sim 1 \times 10^{10} \text{ sec}^{-1}$ ²²
k_R	$9.6 \times 10^5 \text{ sec}^{-1}$	
k_{ET}	1.5×10^{10} L/mol sec	$0.9 \times 10^7 - > 10^8 \text{ sec}^{-1}$ ²⁶ $1.5 \times 10^7 - 4.3 \times 10^9 \text{ sec}^{-1}$ (calculated) ²⁶ $5 \times 10^8 - 1 \times 10^9 \text{ sec}^{-1}$ ²² $7.5 \times 10^9 - 2.6 \times 10^{10}$ L/mol sec (experimental and calculated) ¹⁷ 4×10^{10} L/mol sec in ODCB ⁸

(6) Listing of all publications and technical reports supported under this grant or contract. Provide the list with the following breakout, and in standard format showing authors, title, journal, issue, and date.

(a) Papers published in peer-reviewed journals

Note: Three papers will be submitted during 2001 acknowledging support from this grant. One paper will be submitted to J. Chem. Soc. Perkin 1, and two papers will be submitted to Chem. of Materials.

(b) Papers published in non-peer-reviewed journals or in conference proceedings

“Fourier Transform Techniques for Measuring Absorption of Transient Species in Optical Limiting Materials” Y. Han, W. Sonnenberg, K. Short, and L.H. Spangler, *Proceedings of SPIE* **3798** 93, (1999).

“Photo-Induced Effects In Mn^{4+} :Yag. Observation Of Unusually Efficient Excited State Absorption And A Long - Lived Metastable State.” Yanong Han, Lee H. Spangler, Ralph Hutchison, And Randy W. Equall, *Materials Research Society Fall 1999 Conference Proceedings* In Press.

"Fourier Transform Techniques For Measuring Absorption Of Transient Species In Optical Limiting Materials" Yanong Han, Wendi Sonnenberg, Kurt W. Short, Amy Hyfield And Lee H. Spangler, *Materials Research Society Fall 1999 Conference Proceedings* In Press.

"Excited State Absorption In Dendrimers Incorporating Diphenylaminodiphenylpolyene Moieties Via Photo-Induced Electron Transfer" W. Sonnenberg, A. Hyfield, K. Short, L. Spangler, C. Spangler, *Materials Research Society Fall 1999 Conference Proceedings* In Press.

"Photogeneration of Highly Absorbing Transient Charge States from Model Dendritic Macromolecules Based on Bis-(diphenylamino)diphenylpolyene Repeat Units" A. Hyfield, W. Sonnenberg, Y. Han, L. H. Spangler, E.H. Elanddaloussi and C.W. Spangler *J. Nonlinear Optical Physics and Materials*, In Press.

B. Ozer, B.-S. Kang and C. W. Spangler, "Optical limiting characteristics of dendron and dendrimers incorporating dithienylpolyene moieties", *Mat. Res. Soc. Symp. Proc.* **597**, 389 (2000).

K. Ashworth, B. Reeves, A. Frost, C. Spangler, L. Sapochak, A. Padmaperuma and G. Schmett, *Mat. Res. Soc. Symp. Proc.* **598**, BB3.35.1 (2000).

(7) List of all participating scientific personnel showing any advanced degrees earned by them while employed on the project

Amy Hyfield M.S. Physical Chemistry 2000

Yanong Han Postdoctoral Fellow

Undergraduates: Ben Reeves, Amy Frost – both received B.S. degrees during tenure of grant.

Graduate students: Kimba Ashworth (M.S.), Berrak Ozer (M.S.)

(8) Report of Inventions (by title only)

(9) Bibliography

1. Reuters News Service, Chicago Tribune, Sect, 1, p. 24, May 4, 1995.
2. D.A. Tomalia and H.D.J. Hurst, *Topics in Current Chemistry 165: Supramolecular Chemistry I- Directed Synthesis and Molecular Recognition*, E. Weber, ed., Springer-Verlag, Berlin, 1993, pp. 193-313
3. J.M. Fréchet, *Science*, 1994, **263**, 1710, (1994).
4. C.W. Spangler, P.-K. Liu and K.O. Havelka, *J. Chem. Soc. Perkin Trans. 2*, 715 (1992)
5. C.W. Spangler and P.-K. Liu, *J. Chem. Soc. Perkin Trans 2*, 1959 (1992)
6. C.W. Spangler and M.Q. He, *J. Chem. Soc. Perkin Trans 1*, 715 (1995)
7. C.W. Spangler and M.Q. He, *Mat. Res. Soc. Symp. Proc.*, 413, 221 (1996)
8. C. Spangler and M. He, in Handbook of conductive Molecules and Polymers, Vol. 2. Conductive Polymers: Synthesis and Electrical Properties, H. Nalwa, ed., John Wiley, NY, 1997, pp. 389-414.
9. C. W. Spangler, R. K. McCoy, A. A. Dembeck, L. Sapochak and B. D. Gates, "Preparation of p,p'-disubstituted- α,ω -diphenyl polyenes", *J. Chem. Soc. Perkin Trans. 1*, 151 (1989).
10. E. H. Elanddaloussi, C. Spangler, M. Casstevens, D. Kumar, J. Weibel, R. Burzynski, G.-S. He and P. Prasad, "Optical power limiters for nanosecond pulses: Design of new dendritic chromophores with exceptionally large two-photon cross-sections", *Mat. Res. Soc. Symp. Proc.* **597**, 339 (2000).